



**FACSIMILE EQUIPMENT
SERVICE MANUAL**

**MODELS: MFC7420/7820N
DCP7010/7020/7025**

Confidential

© Copyright Brother 2004

All rights reserved.

No part of this publication may be reproduced in any form or by any means without permission in writing from the publisher.

Specifications are subject to change without notice.

Confidential

PREFACE

This Service Manual is intended for use by service personnel and details the specifications, construction, theory of operation, and maintenance for the Brother machines noted on the front cover. It includes information required for troubleshooting and service--disassembly, reassembly, and lubrication--so that service personnel will be able to understand equipment function, repair the equipment in a timely manner and order spare parts as necessary.

To perform appropriate maintenance so that the machine is always in the best possible condition for the customer, service personnel must adequately understand and apply this manual.

HOW THIS MANUAL IS ORGANIZED

This manual is made up of nine chapters and appendices.

CHAPTER 1 PARTS NAMES AND FUNCTIONS

Contains external views and names of components and describes their functions. Information about the keys on the control panel is included to help you check operation or make adjustments.

CHAPTER 2 SPECIFICATIONS

Lists the specifications of each model, which enables you to make a comparison of different models.

CHAPTER 3 THEORY OF OPERATION

Gives an overview of the scanning and printing mechanisms as well as the sensors, actuators, and control electronics. It aids in understanding the basic principles of operation as well as locating defects for troubleshooting.

CHAPTER 4 TRANSFER OF DATA LEFT IN THE MACHINE TO BE SENT FOR REPAIR

Describes how to transfer data left in the machine to be sent for repair. The service personnel should instruct end users to follow the transfer procedure given in this chapter if the machine at the user site cannot print received data due to the printing mechanism defective. End users can transfer received data to another machine to prevent data loss.

CHAPTER 5 DISASSEMBLY/REASSEMBLY AND LUBRICATION

Details procedures for disassembling and reassembling the machine together with related notes. The disassembly order flow provided enables you to see at a glance the quickest way to get to component(s) involved.

At the start of a disassembly job, you check a disassembly order flow that guides you through a shortcut to the object components.

This chapter also covers screw tightening torques and lubrication points to which the specified lubricants should be applied during reassembly jobs.

CHAPTER 6 ADJUSTMENTS AND UPDATING OF SETTINGS REQUIRED AFTER PARTS REPLACEMENT

Details adjustments and updating of settings, which are required if the head/carriage unit, main PCB and some other parts have been replaced.

CHAPTER 7 CLEANING

Provides cleaning procedures not covered by the User's Manual. Before starting any repair work, clean the machine as it may solve the problem concerned.

CHAPTER 8 MAINTENANCE MODE

Describes the maintenance mode which is exclusively designed for the purpose of checks, settings and adjustments using the keys on the control panel.

In the maintenance mode, you can update memory (EEPROM: electrically erasable programmable read-only memory) contents for optimizing the drive conditions of the head/carriage unit, paper feed roller or paper ejection roller (if they have been replaced) or for setting the CIS scanner area, for example. You can also customize the EEPROM according to the shipment destination of the machine concerned. In addition, you can perform operational checks of the LCD, control panel PCB or sensors, perform a print test, display the log information or error codes, and modify firmware switches (WSW).

CHAPTER 9 ERROR INDICATION AND TROUBLESHOOTING

Details error messages and codes that the incorporated self-diagnostic functions display if any error or malfunction occurs. If any error message appears, refer to this chapter to find which components should be checked or replaced.

The latter half of this chapter provides sample problems that could occur in the main sections of the machine and related troubleshooting procedures. This will help service personnel pinpoint and repair defective components.

APPENDIX 1 SERIAL NUMBERING SYSTEM

Shows the location of serial number labels put on some parts and lists the coding information pertaining to the serial numbers.

APPENDIX 2 FIRMWARE INSTALLATION

Provides instructions on how to update firmware stored in the flash ROM on the main PCB or load firmware to a new main PCB from the host PC.

No hardware replacement is required for updating.

APPENDIX 3 CUSTOMIZING CODES ACCORDING TO SHIPPING DESTINATION

Lists the customizing codes for the various preferences exclusively designed for each destination (e.g. language). Those codes are stored in the memory (EEPROM) mounted on the main PCB. If the main PCB is replaced with a new one, therefore, you will need to set the proper customizing codes with the machine in the maintenance mode.

APPENDIX 4 FIRMWARE SWITCHES (WSW)

Describes the functions of the firmware switches, which can be divided into two groups: one is for customizing preferences designed for the shipping destination (as described in [Appendix 3](#)) and the other is for modifying preferences that match the machine to the environmental conditions. Use the latter group if the machine malfunctions due to mismatching.

APPENDIX 5 WIRING DIAGRAM

Provides the wiring diagram that helps you understand the connections between PCBs.

APPENDIX 6 CIRCUIT DIAGRAMS

Provides the circuit diagrams of the NCU PCB and power supply PCB.

This manual describes the models and their versions destined for major countries. The specifications and functions are subject to change depending upon each destination.

TABLE OF CONTENTS

CHAPTER 1 PARTS NAMES & FUNCTIONS

1.1	EQUIPMENT OUTLINE.....	1-1
1.2	CONTROL PANEL	1-2
1.3	COMPONENTS	1-4

CHAPTER 2 SPECIFICATIONS

2.1	GENGERAL.....	2-1
2.1.1	General Specifications	2-1
2.1.2	Paper Specifications.....	2-2
2.1.3	Printable Area	2-4
2.2	SPECIFICATIONS LIST	2-8

CHAPTER 3 THEORY OF OPERATION

3.1	OVERVIEW.....	3-1
3.2	MECHANICAL COMPONENTS	3-2
3.2.1	Scanner Mechanism	3-3
3.2.2	Printing Mechanism.....	3-6
3.2.2.1	Paper supply	3-6
3.2.2.2	Push-up function of paper tray.....	3-8
3.2.2.3	Paper registration.....	3-10
3.2.2.4	Paper eject.....	3-11
3.2.2.5	Drum unit.....	3-11
3.2.2.6	Toner cartridge.....	3-12
3.2.2.7	Print process	3-15
3.2.3	Sensors and Actuators.....	3-18
3.3	CONTROL ELECTRONICS	3-19
3.3.1	Components.....	3-19

CHAPTER 4 TRANSFER OF DATA LEFT IN THE MACHINE TO BE SENT FOR REPAIR

4.1	TRANSFERRING RECEIVED FAX DATA	4-1
-----	--------------------------------------	-----

CHAPTER 5 DISASSEMBLY/REASSEMBLY AND LUBRICATION

5.1 DISASSEMBLY/REASSEMBLY	5-1
■ Safety Precautions	5-1
■ Tightening Torque.....	5-2
■ Preparation	5-3
■ How to Access the Object Component	5-3
■ Disassembly Flowchart.....	5-4
5.1.1 AC Cord.....	5-5
5.1.2 Drum/Toner ASSY.....	5-5
5.1.3 Paper Tray.....	5-6
5.1.4 Rear Cover	5-7
5.1.5 Rear Chute Cover	5-8
5.1.6 Side Cover L.....	5-9
5.1.7 Side Cover R.....	5-10
5.1.8 ADF Unit.....	5-11
5.1.9 Pull Arm/Pull Arm Guide/Lock Claw Pull Arm Spring.....	5-25
5.1.10 Scanner Unit.....	5-26
5.1.11 Panel Unit.....	5-26
5.1.12 NCU PCB	5-30
5.1.13 Speaker	5-31
5.1.14 Joint Cover ASSY/Paper Stopper/Battery ASSY.....	5-33
5.1.15 Front Cover	5-36
5.1.16 Pickup Roller Holder ASSY	5-38
5.1.17 Fixing Unit	5-42
5.1.18 High-Voltage PS PCB ASSY	5-48
5.1.19 Main PCB	5-49
5.1.20 PS PCB Unit.....	5-51
5.1.21 Laser Unit.....	5-54
5.1.22 Sub Chute ASSY.....	5-56
5.1.23 Link Lever.....	5-57

5.1.24	Tail Edge Actuator.....	5-58
5.1.25	Regist Front Actuator/Regist Front Spring	5-58
5.1.26	Regist Sensor PCB ASSY	5-59
5.1.27	Regist Rear Actuator/Regist Rear Spring.....	5-59
5.1.28	Fan Motor 60 Unit.....	5-60
5.1.29	Toner LED PCB ASSY/LED Holder	5-61
5.1.30	New Toner Actuator/New Toner Actuator Spring.....	5-62
5.1.31	New Toner Sensor	5-62
5.1.32	Cover Sensor	5-63
5.1.33	Toner Sensor PCB ASSY.....	5-63
5.1.34	Main Motor ASSY	5-64
5.1.35	Develop Joint.....	5-65
5.1.36	P/R Solenoid ASSY	5-65
5.1.37	F/R Solenoid ASSY	5-66
5.1.38	Main Frame L	5-68
5.1.39	Main Frame R.....	5-69
5.1.40	Harness Routing.....	5-70
5.2	LUBRICATION	5-78

CHAPTER 6 ADJUSTMENTS AND UPDATING OF SETTINGS, REQUIRED AFTER PARTS REPLACEMENT

6.1	IF YOU REPLACE THE MAIN PCB	6-1
[1]	Load update programs/data.....	6-1
[2]	Initialize the EEPROM on the main PCB (Function code 01)	6-1
[3]	Customize the EEPROM on the main PCB (Function code 74)	6-1
[4]	Check the control panel PCB for normal operation (Function code 13)	6-1
[5]	Make a sensor operation check (Function code 32).....	6-1
[6]	Acquire of white level data and set the CIS scanner area (Function code 55)	6-1
[7]	Setting the serial number	6-1
[8]	Inputting the adjusted value of the laser scanner	6-1
[9]	Switch back to standby	6-1

CHAPTER 7 CLEANING

CHAPTER 8 MAINTENANCE MODE

8.1	ENTRY INTO THE MAINTENANCE MODE	8-1
8.2	LIST OF MAINTENANCE MODE FUNCTIONS.....	8-2
8.3	USER-ACCESS TO THE MAINTENANCE MODE	8-3
8.4	DETAILED DESCRIPTION OF MAINTENANCE MODE FUNCTIONS.....	8-4
8.4.1	EEPROM Parameter Initialization (Function code 01/91)	8-4
8.4.2	Printout of Scanning Compensation Data (Function code 05)	8-5
8.4.3	Placement of CIS Unit in Position for Transportation (Function mode 06)	8-7
8.4.4	ADF Performance Test (Function mode 08)	8-7
8.4.5	Test Pattern 1 (Function mode 09)	8-8
8.4.6	Firmware Switch Setting and Printout	8-9
8.4.6.1	Firmware switch setting (Function mode 10)	8-9
8.4.6.2	Printout of firmware switch data (Function mode 11).....	8-11
8.4.7	Operation Check of LCD (Function mode 12).....	8-12
8.4.8	Operational Check of Control Panel PCB (Function mode 13).....	8-13
8.4.9	Sensor Operational Check (Function mode 32).....	8-14
8.4.10	Received Data Transfer Function (Function mode 53)	8-15
8.4.11	Fine Adjustment of Scan Start/End Positions (Function mode 54)	8-17
8.4.12	Acquisition of White Level Data and CIS Scanner Area Setting (Function mode 55).....	8-19
8.4.13	Paper Feeding and Ejecting Test (Function mode 67).....	8-19
8.4.14	EEPROM Customizing (Function mode 74).....	8-20
8.4.15	Display of the Equipment's Log Information (Function mode 80)	8-21
8.4.16	Machine Error Code Indication (Function mode 82)	8-23
8.4.17	Output of Transmission Log to the Telephone Line (Function mode 87).....	8-23
8.4.18	Cancellation of the Memory Security Mode (Not applicable to the Japanese model)	8-23

CHAPTER 9 ERROR INDICATION AND TROUBLESHOOTING

9.1 ERROR INDICATION	9-1
9.1.1 Equipment Errors	9-1
[1] Error messages appearing on the LCD	9-1
[2] Error codes shown in the "MACHINE ERROR X X" messages.....	9-5
9.1.2 Communications Errors.....	9-11
9.2 TROUBLESHOOTING	9-15
9.2.1 Introduction.....	9-15
9.2.2 Precautions	9-15
9.2.3 Checking Prior to Troubleshooting.....	9-15
9.2.4 Troubleshooting Based on Problem Type.....	9-16
[1] Paper feeding problems	9-16
[2] Software setting problems	9-18
[3] Malfunction.....	9-21
[4] Image defects	9-27
[5] Incorrect printout	9-48
[6] Network problem.....	9-50
[7] Troubleshooting of the control panel.....	9-54
[8] Troubleshooting of fax functions	9-56

APPENDIX 1 SERIAL NUMBERING SYSTEM

APPENDIX 2 FIRMWARE INSTALLATION

A2.1 INSTALLING THE UPDATE DATA TO THE MACHINE.....	App. 2-1
A2.2 SETTING ID CODES TO MACHINES.....	App. 2-9

APPENDIX 3 CUSTOMIZING CODES ACCORDING TO SHIPPING DESTINATION

APPENDIX 4 FIRMWARE SWITCHES (WSW)

APPENDIX 5 WIRING DIAGRAM

APPENDIX 6 CIRCUIT DIAGRAMS

NCU PCB: MFC7420 (U.S.A. and CANADA models)

NCU PCB: MFC7820N (U.S.A. and CANADA models)

NCU PCB: MFC7420 (EUROPE models)

NCU PCB: MFC7820N (EUROPE models)

Power Supply PCB 100V (U.S.A. and CANADA models)

Power Supply PCB 200V (EUROPE models)









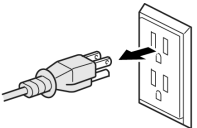

SAFETY PRECAUTIONS

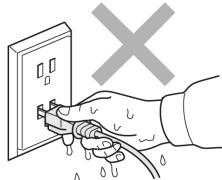
To use the MFC safely

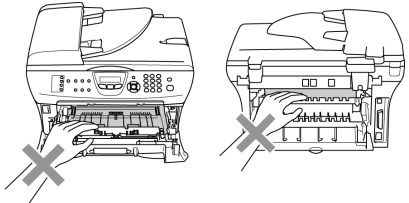
Please keep these instructions for later reference and read them before attempting any maintenance.

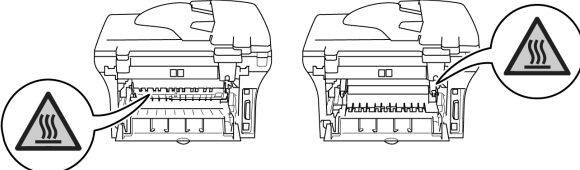
NOTE: If there are faxes in the MFC's memory, you need to print them or save them before you turn off the power and unplug the MFC. (For MFC-7420)

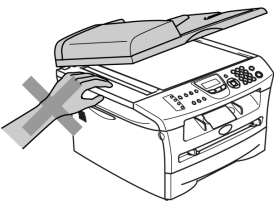
WARNING

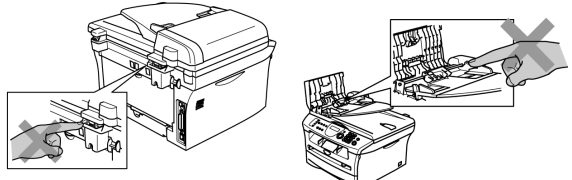
	<p>There are high voltage electrodes inside the MFC. Before you clean the inside of the MFC, make sure you have unplugged the telephone line cord first and then the power cord from the AC power outlet.</p> 
	<p>Do not handle the plug with wet hands. Doing this might cause an electrical shock.</p> 
	<p>After you use the MFC, some internal parts are extremely HOT! To prevent injuries, be careful not to put your fingers in the areas shown in the illustration.</p> 
	<p>The fuser unit is marked with a caution label. Please do not remove or damage the label.</p> 
	<p>To prevent injuries, be careful not to put your hands on the edge of the MFC under the scanner cover.</p> 
	<p>To prevent injuries, be careful not to put your fingers in the area shown in the illustrations.</p> 

Do not use a vacuum cleaner to clean up scattered toner. Doing this might cause the toner dust to ignite inside the vacuum cleaner, potentially starting a fire. Please carefully clean the toner dust with a dry, lint-free cloth and dispose of it according to local regulations.

⚠ WARNING

- When you move the MFC, grasp the side hand holds that are under the scanner. **DO NOT** carry the MFC by holding it at the bottom.
- Use caution when installing or modifying telephone lines. Never touch telephone wires or terminals that are not insulated unless the telephone line has been disconnected at the wall jack. Never install telephone wiring during a lightning storm. Never install a telephone wall jack in a wet location.
- This product must be installed near an AC power outlet that is easily accessible. In case of an emergency, you must disconnect the power cord from the AC power outlet to shut off the power completely.
- To reduce the risk of shock or fire, use only a No. 26 AWG or larger telecommunication line cord.

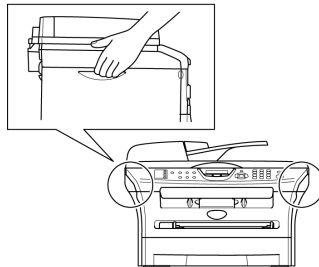

⚠ CAUTION

Lightning and power surges can damage this product! We recommend that you use a quality surge protection device on the AC power line and on the telephone line, or unplug the cords during a lightning storm.

⚠ WARNING

IMPORTANT SAFETY INSTRUCTIONS

When using your telephone equipment, basic safety precautions should always be followed to reduce the risk of fire, electric shock and injury to people, including the following:

1. Do not use this product near water, for example, near a bath tub, wash bowl, kitchen sink or washing machine, in a wet basement or near a swimming pool.
2. Avoid using this product during an electrical storm. There may be a remote risk of electric shock from lightning.
3. Do not use this product to report a gas leak in the vicinity of the leak.
4. Use only the power cord provided with the MFC.

SAVE THESE INSTRUCTIONS

CHOOSING A LOCATION

Place your MFC on a flat, stable surface that is free of vibration and shocks, such as a desk. Put the MFC near a telephone wall jack and a standard, grounded AC power outlet. Choose a location where the temperature remains between 50°F and 90.5°F (10°C and 32.5°C).

CAUTION

- Avoid placing your MFC in a high-traffic area.
- Do not place the MFC near heaters, air conditioners, water, chemicals, or refrigerators.
- Do not expose the MFC to direct sunlight, excessive heat, moisture, or dust.
- Do not connect your MFC to an AC power outlet controlled by wall switches or automatic timers.
- Disruption of power can wipe out information in the MFC's memory.
- Do not connect your MFC to an AC power outlet on the same circuit as large appliances or other equipment that might disrupt the power supply.
- Avoid interference sources, such as speakers or the base units of cordless phones.

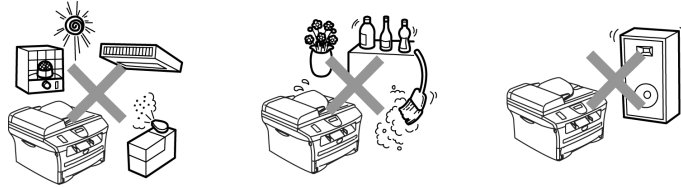

CHAPTER 1

PARTS NAMES & FUNCTIONS

Confidential

CHAPTER 1 PARTS NAMES & FUNCTIONS

This chapter contains external views and names of components and describes their functions. Information about the keys on the control panel is included to help you check operation or make adjustments.

CONTENTS

1.1	EQUIPMENT OUTLINE	1-1
1.2	CONTROL PANEL.....	1-2
1.3	COMPONENTS.....	1-4

Confidential

1.1 EQUIPMENT OUTLINE

Front view

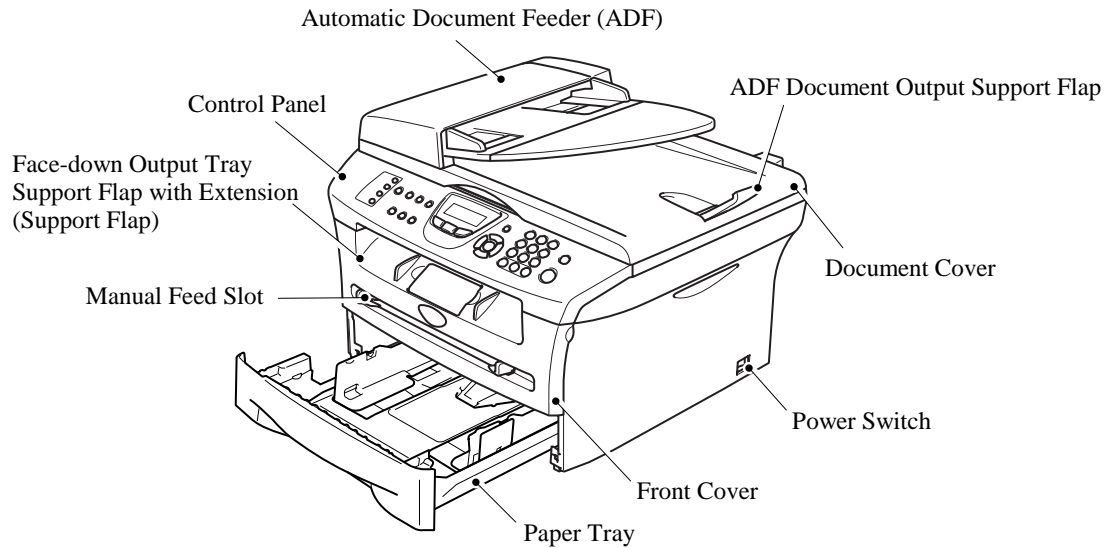



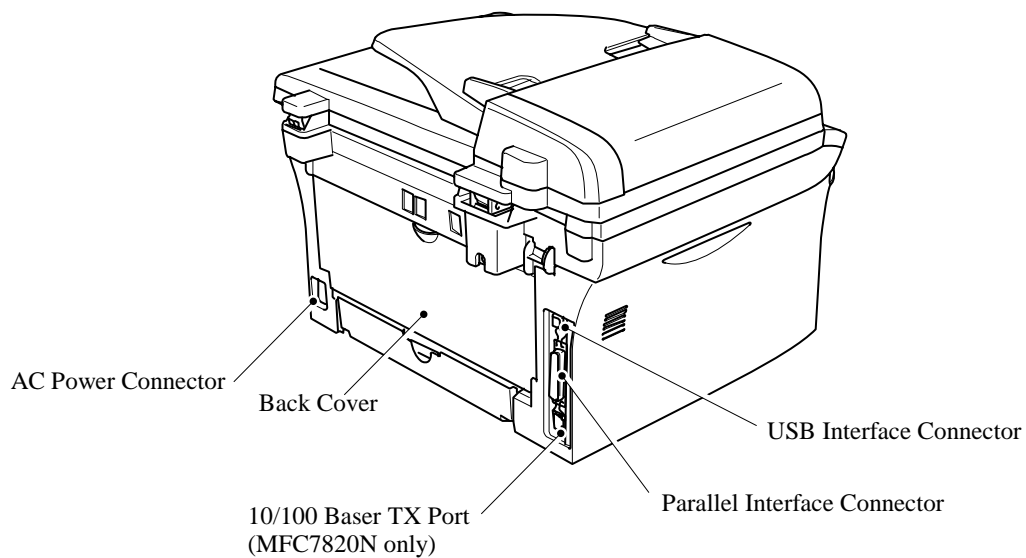

Rear view



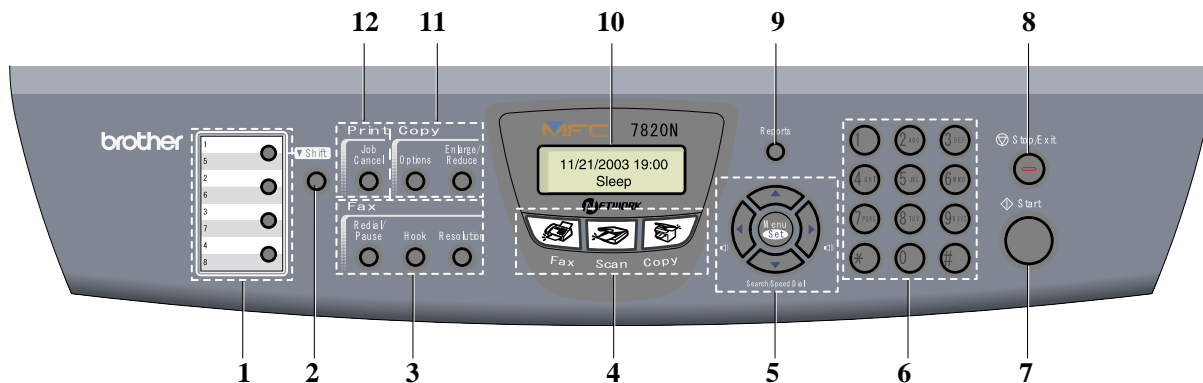

1.2 CONTROL PANEL

MFC-7420 and MFC-7820N have similar control keys.



1. One-Touch Keys
These 4 keys give you instant access to 8 previously stored numbers.
2. Shift Key
To access One-Touch numbers 5 to 8, hold down Shift as you press the One-Touch key.
3. Fax and Telephone Keys
Redial/Pause Redials the last number you called. It also inserts a pause in quick dial numbers.
Hook Press before dialing if you want to make sure a fax machine will answer, and then press Start . Also, press this key after picking up the handset of an external telephone during the F/T double/pseudo-ring.
Resolution Sets the resolution when you send a fax.
4. Mode Keys
 Fax Lets you access Fax mode.
 Scan Lets you access Scan mode.
 Copy Lets you access Copy mode.

6. Dial Pad Keys
Use these keys to dial telephone or fax numbers and as a keyboard for entering information into the MFC. The # key lets you temporarily switch the dialing mode during a telephone call from Pulse to Tone.
7. Start Key
 Lets you start sending faxes or making copies.
8. Stop/Exit Key
 Stops an operation or exits from the menu.
9. Reports Key
Print the Transmission Verification Report, Help List, Quick-Dial List, Fax Journal, User Settings and Network Configuration*. (*MFC-7820N only).
10. Liquid Crystal Display (LCD)
Displays messages on the screen to help you set up and use your MFC.

5. Navigation Keys

Menu/Set

The same key is used for Menu and Set operations. Lets you access the Menu to program and store your settings in the MFC.



When listening to the speaker in Fax mode or on standby, you can press these keys to adjust the volume.

▼ Search/Speed Dial

Lets you look up numbers that are stored in the dialing memory. It also lets you dial stored numbers by pressing # and a three-digit number.



Press to scroll forward or backward to a menu selection.



Press to scroll through the menus and options.

11. Copy Keys (Temporary settings)

Enlarge/Reduce

Lets you reduce or enlarge copies depending upon the ratio you select.

Options

You can quickly and easily select temporary settings for copying.

12. Printer Key

Job Cancel

You can cancel a print job and clear the printer memory.

1.3 COMPONENTS

The equipment consists of the following major components:

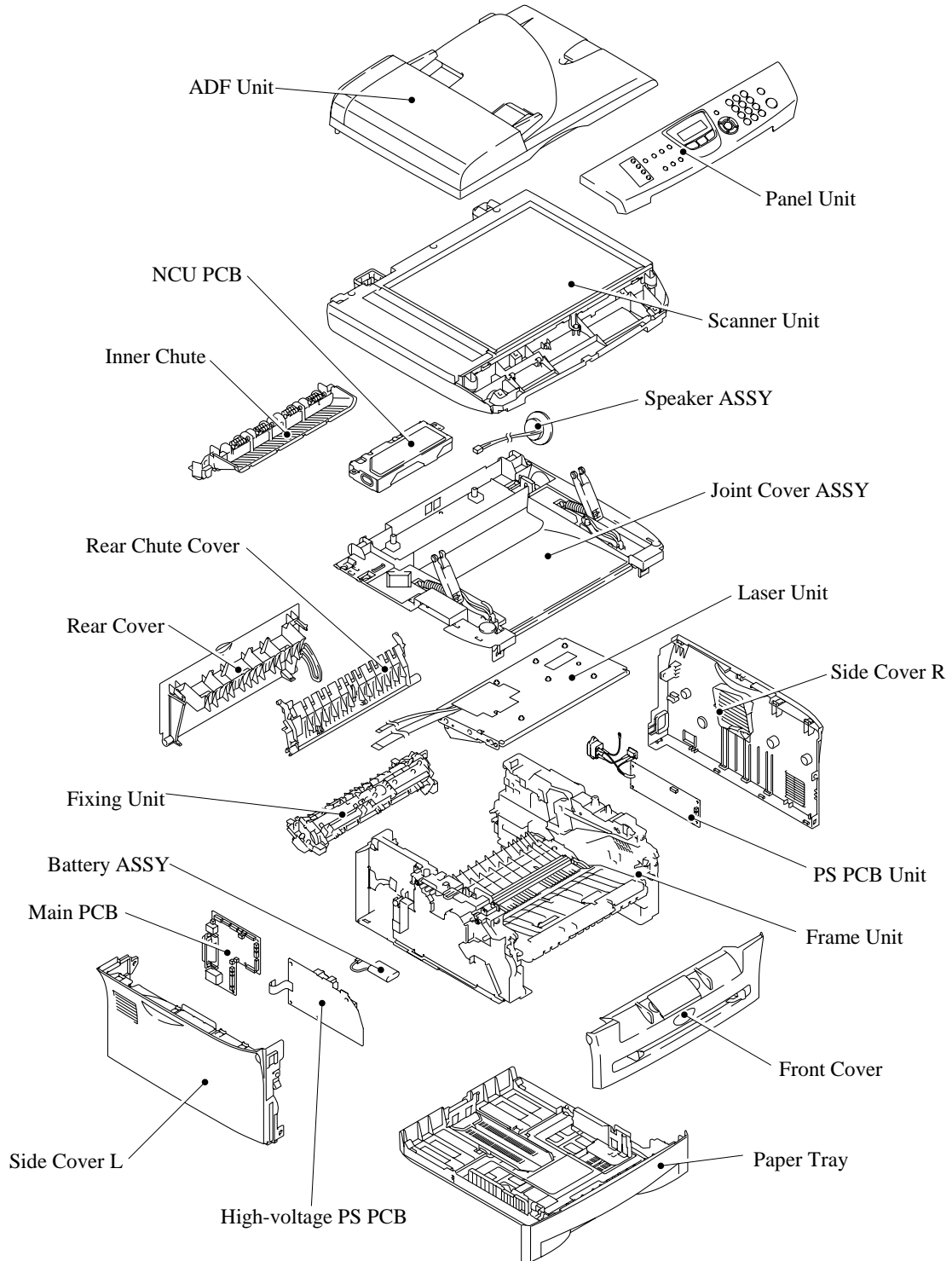

CHAPTER 2

SPECIFICATIONS

Confidential

CHAPTER 2 SPECIFICATIONS

This chapter lists the specifications of each model, which enables you to make a comparison of different models.

CONTENTS

2.1	GENERAL	2-1
2.1.1	General Specifications	2-1
2.1.2	Paper Specifications.....	2-2
2.1.3	Printable Area	2-4
2.2	SPECIFICATIONS LIST	2-8

Confidential

2.1 GENERAL

2.1.1 General Specifications

Memory Capacity	16 MB (MFC-7420), 32 MB (MFC-7820N)
Automatic Document Feeder (ADF)	Up to 35 sheets
Paper Tray	250 Sheets (20 lb (75 g/m ²))
Printer Type	Laser
Print Method	Electrophotography by semiconductor laser beam scanning
Liquid Crystal Display (LCD)	16 characters x 2 lines
Power Source	100 to 120V AC 50/60Hz
Power Consumption	(MFC-7420) Minimum: Under 10 watts Standby: 75 Wh or less (25°C) Peak: 1032 Wh or less (MFC-7820N) Minimum: Under 10 watts Standby: 75 Wh or less (25°C) Peak: 1032 Wh or less
Dimensions (W x D x H)	432mm x 395mm x 294mm (with out carton)
Weight	Without Drum/Toner Unit: 20.7 lb (9.4 kg)
Noise	Operating: 53 dB A or less Standby: 30 dB A or less
Temperature	Operating: 50°F to 90.5°F (10 to 32.5°C) Storage: 32°F to 104°F (0 to 40°C)
Humidity	Operating: 20 to 80% (without condensation) Storage: 10 to 90% (without condensation)

2.1.2 Paper Specifications

(1) Paper type

Paper type	Tray1	Manual feed slot	Select the paper type from the printer driver
Plain paper 60 g/m ² to 105 g/m ² (16 to 28 lbs.)	○	○	Plain paper
Recycled paper	○	○	Recycled paper
Bond paper	○	○	Bond paper
Thick paper 105 g/m ² to 161 g/m ² (28 to 43 lbs.)	X	○	Thick paper or Thicker paper
Transparency	○ Up to 10 sheets A4 or Letter	○	Transparency
Label	X	○	Thicker paper
Envelop	X	○	Envelope or Env.Thick or Env.Thin
Card Stock	X	○	Thick paper or Thicker paper

(2) Paper size

	Paper Tray	Manual feed slot
Paper size	A4, Letter, Legal*, , B5 (ISO), Executive, A5, A6, B6 (ISO), B5 (JIS), Folio*	Width: 69.9 to 215.9 mm (2.75 to 8.5 in.) Length: 116 to 406.4 mm (4.57 to 16.0 in.)

* Legal and Folio are not available in some regions.

(3) Other paper specifications

<Paper tray>

	Cut sheet
Basis weight	60 to 105 g/m ² (16 to 28 lb.)
Caliper	0.08 to 0.12 mm (0.003 to 0.005 in.)
Moisture content	4% to 6% by weight

<Manual feed slot>

	Cut sheet
Basis weight	60 to 161 g/m ² (16 to 43 lb.)
Caliper	0.08 to 0.19 mm (0.003 to 0.007 in.)
Moisture content	4% to 6% by weight

(4) Recommended paper

	Europe	USA
Plain paper	Xerox Premier 80 g/m ² Xerox Business 80 g/m ² Modo Paper DATACOPY 80 g/m ² IGEPA X-press 80 g/m ²	Xerox 4200DP 20lb Xerox 4024 28lb Hammermill Laser Paper 24lb
Recycled paper	Xerox Recycled Supreme	N/A
Transparency	3M CG3300	3M CG 3300
Label	Avery laser label L7163	Avery laser label #5160

* This printer can use recycled paper that meets the DIN 19309 specification

CAUTION:

When you are choosing print media, be sure to follow the information given below to prevent any paper jams, print quality problems or printer damage;

- It is recommended to use long-grained paper for the best print quality. If short-grained paper is being used, it might be the cause of paper jams.
- Use neutral paper. Do not use acid paper to avoid any damage to the drum unit.
- Avoid using coated paper such as vinyl coated paper.
- Avoid using preprinted or highly textured paper.
- It is recommended to use labels or transparencies which are designed for use in laser printers.
- Avoid feeding labels with the carrier sheet exposed, or the printer will be damaged.
- Before loading paper with holes such as organizer sheets, be sure to fan the stack well.
- Do not use organizer sheets that are stuck together. The glue that is used might caused damaged to the printer.
- When printing on the back of pre-printed paper, if the paper is curled, be sure to straighten the paper as much as possible.

Different types of paper should not be loaded at the same time in the paper tray to avoid any paper jams or misfeeds.

(5) Paper tray capacity

	Paper Tray	Manual feed slot
Paper Capacity	250 sheets (80 g/m ² or 21lb)	Single sheet

(6) Print delivery

Face down output tray

capacity: Maximum 100 sheets (80 g/m²)
face down only

NOTE:

Face-down: Delivery with the printed face of the paper downwards.

2.1.3 Printable Area

When using PCL emulation, the edges of the paper that cannot be printed on are shown below.

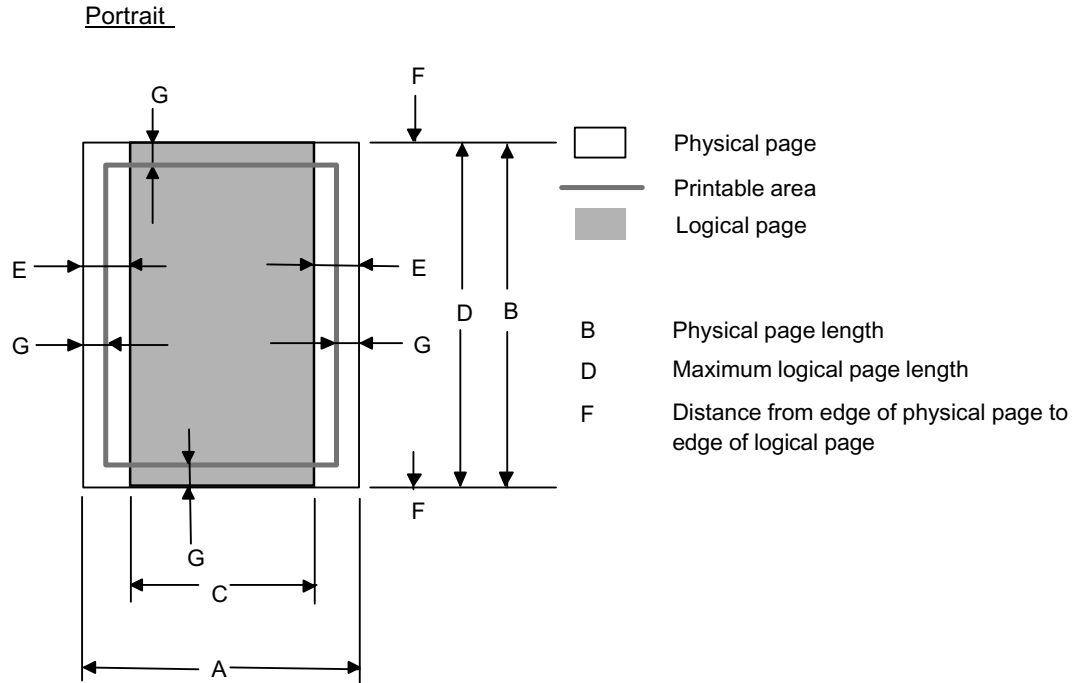

NOTE:

- “Logical page” shows the printable area for a PCL driver.
- “Printable area” shows mechanical printable area of the machine.
- Therefore, the machine can only print within the shaded area when you use a PCL driver.

The table below shows the printable areas when printing on Portrait for each paper size.

Size	A	B	C	D	E	F	G
Letter	215.9 mm 8.5" (2,550 dots)	279.4 mm 11.0" (3,300 dots)	203.2 mm 8.0" (2,400 dots)	279.4 mm 11.0" (3,300 dots)	6.35 mm 0.25" (75 dots)	0 mm	4.2 mm 0.16" (50 dots)
Legal	215.9 mm 8.5" (2,550 dots)	355.6 mm 14.0" (4,200 dots)	203.2 mm 8.0" (2,400 dots)	355.6 mm 14.0" (4,200 dots)	6.35 mm 0.25" (75 dots)	0 mm	4.2 mm 0.16" (50 dots)
Folio	215.9 mm 8.5" (2,550 dots)	330.2mm 13.0" (3,900 dots)	203.2 mm 8.0" (2,400 dots)	330.2mm 13.0" (3,900 dots)	6.35 mm 0.25" (75 dots)	0 mm	4.2 mm 0.16" (50 dots)
Executive	184.15 mm 7.25" (2,175 dots)	266.7 mm 10.5" (3,150 dots)	175.7 mm 6.92" (2,025 dots)	266.7 mm 10.5" (3,150 dots)	6.35 mm 0.25" (75 dots)	0 mm	4.2 mm 0.16" (50 dots)
A4	210.0 mm 8.27" (2,480 dots)	297.0 mm 11.69" (3,507 dots)	198.0 mm 7.79" (2,338 dots)	297.0 mm 11.69" (3,507 dots)	6.01 mm 0.24" (71 dots)	0 mm	4.2 mm 0.16" (50 dots)
A5	148.5 mm 5.85" (1,754 dots)	210.0 mm 8.27" (2,480 dots)	136.5 mm 5.37" (1,612 dots)	210.0 mm 8.27" (2,480 dots)	6.01 mm 0.24" (71 dots)	0 mm	4.2 mm 0.16" (50 dots)
A6	105.0 mm 4.13" (1,240 dots)	148.5 mm 5.85" (1,754 dots)	93.0 mm 3.66" (1,098 dots)	148.5 mm 5.85" (1,754 dots)	6.01 mm 0.24" (71 dots)	0 mm	4.2 mm 0.16" (50 dots)
B5 (JIS)	182.0 mm 7.1" (2,130 dots)	257.0 mm 10.11" (3,033 dots)	170.0 mm 6.69" (2,007 dots)	257.0 mm 10.11" (3,033 dots)	6.01 mm 0.24" (71 dots)	0 mm	4.2 mm 0.16" (50 dots)
B5 (ISO)	176.0 mm 6.93" (2,078 dots)	250.0 mm 9.84" (2,952 dots)	164.0 mm 6.46" (1,936 dots)	250.0 mm 9.84" (2,952 dots)	6.01 mm 0.24" (71 dots)	0 mm	4.2 mm 0.16" (50 dots)
B6 (ISO)	125.0 mm 4.92" (1,476 dots)	176.0 mm 6.93" (2,078 dots)	164.0 mm 4.44" (1,334 dots)	176.0 mm 6.93" (2,078 dots)	6.01 mm 0.24" (71 dots)	0 mm	4.2 mm 0.16" (50 dots)
COM10	104.78 mm 4.125" (1,237 dots)	241.3 mm 9.5" (2,850 dots)	92.11 mm 3.63" (1,087 dots)	241.3 mm 9.5" (2,850 dots)	6.35 mm 0.25" (75 dots)	0 mm	4.2 mm 0.16" (50 dots)
MONARCH	98.43 mm 3.875" (1,162 dots)	190.5 mm 7.5" (2,250 dots)	85.7 mm 3.37" (1,012 dots)	190.5 mm 7.5" (2,250 dots)	6.35 mm 0.25" (75 dots)	0 mm	4.2 mm 0.16" (50 dots)
C5	162.0 mm 6.38" (1,913 dots)	229.0 mm 9.01" (2,704 dots)	150.0 mm 5.9" (1,771 dots)	229.0 mm 9.01" (2,704 dots)	6.01 mm 0.24" (71 dots)	0 mm	4.2 mm 0.16" (50 dots)
DL	110.0 mm 4.33" (1,299 dots)	220.0 mm 8.66" (2,598 dots)	98.0 mm 3.86" (1,157 dots)	220.0 mm 8.66" (2,598 dots)	6.01 mm 0.24" (71 dots)	0 mm	4.2 mm 0.16" (50 dots)
DLL	220.0 mm 8.66" (2,598 dots)	110.0 mm 4.33" (1,299 dots)	207.4 mm 8.17" (2,450 dots)	110.0 mm 4.33" (1,299 dots)	6.27 mm 0.25" (74 dots)	0 mm	6.27 mm 0.25" (74 dots)

NOTE:

- The paper sizes indicated here should confirm to the nominal dimensions specified by JIS except B5 (ISO), B6 (ISO).
- The dot size is based on 300 dpi resolution.

Landscape

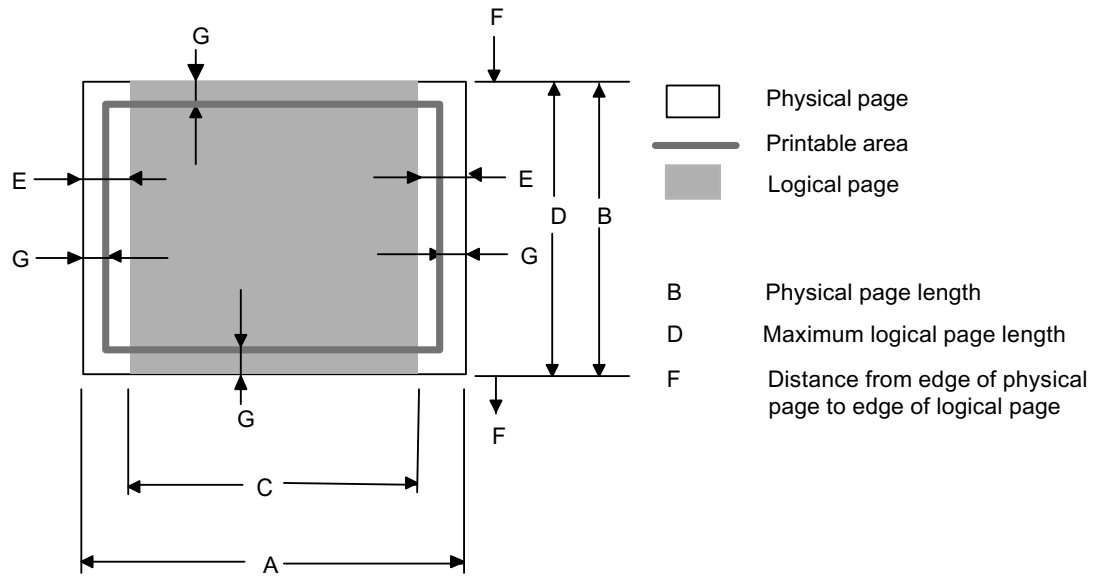

NOTE:

- “Logical page” shows the printable area for a PCL driver.
- “Printable area” shows mechanical printable area of the machine.
- Therefore, the machine can only print within the shaded area when you use a PCL driver.

The table below shows the printable areas when printing on Landscape for each paper size.

Size	A	B	C	D	E	F	G
Letter	279.4 mm 11.0" (3,300 dots)	215.9 mm 8.5" (2,550 dots)	269.3 mm 10.6" (3,180 dots)	215.9 mm 8.5" (2,550 dots)	5.0 mm 0.2" (60 dots)	0 mm	4.2 mm 0.16" (50 dots)
Legal	355.6 mm 14.0" (4,200 dots)	215.9 mm 8.5" (2,550 dots)	345.5 mm 13.6" (4,080 dots)	215.9 mm 8.5" (2,550 dots)	5.0 mm 0.2" (60 dots)	0 mm	4.2 mm 0.16" (50 dots)
Folio	330.2mm 13.0" (3,900 dots)	215.9 mm 8.5" (2,550 dots)	320.0 mm 12.6" (3,780 dots)	215.9 mm 8.5" (2,550 dots)	5.0 mm 0.2" (60 dots)	0 mm	4.2 mm 0.16" (50 dots)
Executive	266.7 mm 10.5" (3,150 dots)	184.15 mm 7.25" (2,175 dots)	256.6 mm 10.1" (3,030 dots)	184.15 mm 7.25" (2,175 dots)	5.0 mm 0.2" (60 dots)	0 mm	4.2 mm 0.16" (50 dots)
A4	297.0 mm 11.69" (3,507 dots)	210.0 mm 8.27" (2,480 dots)	287.0 mm 11.2" (3,389 dots)	210.0 mm 8.27" (2,480 dots)	4.8 mm 0.19" (59 dots)	0 mm	4.2 mm 0.16" (50 dots)
A5	210.0 mm 8.27" (2,480 dots)	148.5 mm 5.85" (1,754 dots)	200.0 mm 7.87" (2,362 dots)	148.5 mm 5.85" (1,754 dots)	4.8 mm 0.19" (59 dots)	0 mm	4.2 mm 0.16" (50 dots)
A6	148.5 mm 5.85" (1,754 dots)	105.0 mm 4.13" (1,240 dots)	138.5 mm 5.45" (1,636 dots)	105.0 mm 4.13" (1,240 dots)	4.8 mm 0.19" (59 dots)	0 mm	4.2 mm 0.16" (50 dots)
B5 (JIS)	257.0 mm 10.11" (3,033 dots)	182.0 mm 7.1" (2,130 dots)	247.0 mm 9.72" (2,916 dots)	182.0 mm 7.1" (2,130 dots)	4.8 mm 0.19" (59 dots)	0 mm	4.2 mm 0.16" (50 dots)
B5 (ISO)	250.0 mm 9.84" (2,952 dots)	176.0 mm 6.93" (2,078 dots)	240.0 mm 9.44" (2,834 dots)	176.0 mm 6.93" (2,078 dots)	4.8 mm 0.19" (59 dots)	0 mm	4.2 mm 0.16" (50 dots)
B6 (ISO)	176.0 mm 6.93" (2,078 dots)	125.0 mm 4.92" (1,476 dots)	166.4 mm 6.55" (1,960 dots)	125.0 mm 4.92" (1,476 dots)	4.8 mm 0.19" (59 dots)	0 mm	4.2 mm 0.16" (50 dots)
COM10	241.3 mm 9.5" (2,850 dots)	104.78 mm 4.125" (1,237 dots)	231.1 mm 9.1" (2,730 dots)	104.78 mm 4.125" (1,237 dots)	5.0 mm 0.2" (60 dots)	0 mm	4.2 mm 0.16" (50 dots)
MONARCH	190.5 mm 7.5" (2,250 dots)	98.43 mm 3.875" (1,162 dots)	180.4 mm 7.1" (2,130 dots)	98.43 mm 3.875" (1,162 dots)	5.0 mm 0.2" (60 dots)	0 mm	4.2 mm 0.16" (50 dots)
C5	229.0 mm 9.01" (2,704 dots)	162.0 mm 6.38" (1,913 dots)	219.0 mm 8.62" (2,586 dots)	162.0 mm 6.38" (1,913 dots)	4.8 mm 0.19" (59 dots)	0 mm	4.2 mm 0.16" (50 dots)
DL	220.0 mm 8.66" (2,598 dots)	110.0 mm 4.33" (1,299 dots)	210.0 mm 8.26" (2,480 dots)	110.0 mm 4.33" (1,299 dots)	4.8 mm 0.19" (59 dots)	0 mm	4.2 mm 0.16" (50 dots)
DLL	110.0 mm 4.33" (1,299 dots)	220.0 mm 8.66" (2,598 dots)	97.5 mm 3.84" (1,151 dots)	220.0 mm 8.66" (2,598 dots)	6.27 mm 0.25" (74 dots)	0 mm	6.27 mm 0.25" (74 dots)

NOTE:

- The paper sizes indicated here should confirm to the nominal dimensions specified by JIS except B5 (ISO), B6 (ISO).
- The dot size is based on 300 dpi resolution.

2.2 SPECIFICATIONS LIST

MFC7420/7820N

(1/15)

	ALL-FB1			ALL-FB2		
	US/Canada	Europe	Asia/Pacific	US/Canada	Europe	Asia/Pacific
Model Name	MFC-7420			MFC-7820N		
GENERAL						
Print Engine	Laser (ALL)			Laser (ALL)		
CPU Speed	SparcLite 133MHz			SparcLite 133MHz		
Back up Clock	2hours			Yes (up to 4 days)		
Operating Environment Temperature	10 - 32.5 degrees Centigrade			10 - 32.5 degrees Centigrade		
Operating Environment Humidity	20% - 80% (without condensation)			20% - 80% (without condensation)		
On/Off Switch	Yes			Yes		
AC Cord inlet	Yes			Yes		
Demo Print	Yes (US only)	N/A		Yes (US only)	N/A	
Demo Model	N/A			N/A		
Starter Toner	Starter	Full		Starter	Full	
Simultaneous Operation	Yes			Yes		
Input / Output Width	5.8"-8.5" / 2.75"-8.5" 147.3-215.9 mm / 69.9-215.9 mm			5.8"-8.5" / 2.75"-8.5" 147.3-215.9 mm / 69.9-215.9 mm		
Input / Output Length	5.8"-14" / 4.56"-16" 147.3-356.0 mm/ 116.0-406.4 mm			5.8"-14" / 4.56"-16" 147.3-356.0 mm/ 116.0-406.4 mm		
ADF	up to 35 sheets			up to 35 sheets		
Paper Capacity	250 sheets			250 sheets		
Optional Paper Tray	N/A			N/A		
Multi-Purpose Tray	N/A			N/A		
Output Paper Capacity (sheets)	up to 100 sheets			up to 100 sheets		
Lower Tray - Automatic Detection	N/A			N/A		
LCD Size	16 characters x 2 lines			16 characters x 2 lines		
LCD Back-Lit	N/A			Yes (1-color)		
On-Screen Programming	Yes			Yes		
Memory Capacity (Standard : MByte)	16 Mbyte (RAM)			32 Mbyte (RAM)		
Memory Backup	N/A			Yes (up to 4 days)		
Optional Memory	N/A			N/A		
Memory Security	N/A			Yes		
Transmission Lock	Yes			N/A		
Setting Lock	Yes			Yes		
Dimensions w/ Carton (WxDxH)	550mm x 495mm x 500mm			550mm x 495mm x 500mm		
Dimensions w/o Carton (WxDxH)	432mm x 395mm x 294mm			432mm x 395mm x 294mm		
Weight w/ Carton	13.8kg	14.5kg		14kg	14.7kg	
Weight w/o Carton	9.45kg			9.5kg		
Color	Front/Top cover: 1581 gray, Side cover: 1736 gray			Front/Top cover: 1736 gray, Side cover: 1581 gray		

	ALL-FB1			ALL-FB2		
	US/Canada	Europe	Asia/Pacific	US/Canada	Europe	Asia/Pacific
Model Name	MFC-7420			MFC-7820N		
GENERAL						
Power Source	120V AC 50/60 (Canada)Hz	220-240V AC 50/60Hz		120V AC 50/60 (Canada)Hz	220-240V AC 50/60Hz	
Power Consumption (Copying)	460W			460W		
Power Consumption (Sleep/Standby/Peak)	AVERAGE 10W/75W/1032W			AVERAGE 10W/75W/1032W		
Power Save (CPU Sleep)	N/A			N/A		
Sleep Mode (00-99min : w/ OFF mode)	Yes			Yes		
Energy Star Compliant (USA Only)	Yes	N/A		Yes	N/A	
Total Print pages Counter (Internal / LCD / Print)	Yes / Yes/ Yes			Yes / Yes/ Yes		
Copy pages Counter (Internal / LCD / Print)	Yes / Yes/ Yes			Yes / Yes/ Yes		
PC print pages Counter (Internal / LCD / Print)	Yes / Yes/ Yes			Yes / Yes/ Yes		
Fax RX pages counter (Internal / LCD / Print)	Yes / Yes/ Yes			Yes / Yes/ Yes		
Warm up Time (from SLEEP mode)	Max. 18 sec. at 73.4 F (23C)			Max. 18 sec. at 73.4 F (23C)		
Paper Type(Media) Setting	Yes			Yes		
TELEPHONE						
Handset	N/A			N/A		
Off Hook Alarm	N/A			N/A		
Power Failure Phone	N/A			N/A		
Power Failure Dialing	N/A			N/A		
Chain Dialing	Yes			Yes		
Automatic Redial	Yes			Yes		
PBX Feature	N/A	Yes	N/A	N/A	Yes	N/A
Speaker Phone	N/A			N/A		
Handset Volume	N/A			N/A		
Speaker Volume	Yes (3 steps + OFF)			Yes (3 steps + OFF)		
Buzzer Volume	Yes (3 steps + OFF)			Yes (3 steps + OFF)		
Ring Volume	Yes (3 steps + OFF)			Yes (3 steps + OFF)		
Hold/Mute Key	N/A			N/A		
Music on Hold	N/A			N/A		
Monitoring the Line on Hold with Music	N/A			N/A		
One-Touch Dial	8 (4 x 2) locations			8 (4 x 2) locations		
Speed Dial	200 locations			200 locations		

	ALL-FB1			ALL-FB2		
	US/Canada	Europe	Asia/Pacific	US/Canada	Europe	Asia/Pacific
Model Name	MFC-7420			MFC-7820N		
TELEPHONE						
Telephone Index (Search)	Yes (with key)			Yes (with key)		
Pre-registered for FAX BACK SYSTEM (USA)	N/A			N/A		
Caller ID	Yes	N/A	Yes (ARL/NZ/SIN/ HK only)	Yes	N/A	Yes (ARL/NZ/SIN/ HK only)
Call Waiting Caller ID	N/A			N/A		
Call waiting Ready (Only for USA)	N/A			N/A		
Distinctive Ringing	Yes	Yes (U.K., Den. only)	Yes (ARL/NZ/SIN/ HK only)	Yes	Yes (U.K., Den. only)	Yes (ARL/NZ/SIN/ HK only)
FAX						
Modem Speed	14.400bps (Fax)			33.600bps (Fax)		
Transmission Speed	Approx. 6sec. (ITU-T #1 & Brother#1,MMR)			Approx. 2sec. (ITU-T #1 & Brother#1,JBIG)		
ITU-T Group	G3			Super G3		
Coding Method	MH / MR / MMR			MH / MR / MMR / JBIG		
Color FAX (Document Send / Receive)	N/A / N/A			N/A / N/A		
Color FAX (Memory Send / Receive)	N/A / N/A			N/A / N/A		
Fax/Tel Switch	Yes			Yes		
Super Fine	Yes (TX & RX)			Yes (TX & RX)		
Gray Scale	64			64		
Contrast	Yes (Auto/Light/Dark)			Yes (Auto/Light/Dark)		
Smoothing	N/A			N/A		
Dual Access	Yes			Yes		
Enhanced Remote Activate	Yes			Yes		
Station ID	Yes (20digits / 20characters)			Yes (20digits / 20characters)		
Remote Maintenance	Yes			Yes		
RX Mode Indication	LCD			LCD		
Resolution Indication	LCD			LCD		
Delayed Timer	Yes (up to 50)			Yes (up to 50)		
Polled Sending	Yes (Eur Secure Polling)			Yes (Eur Secure Polling)		
Multi Transmission	N/A			N/A		
Multi Resolution Transmission	N/A			N/A		
Next-Fax Reservation	N/A			N/A		
Batch Transmission	Yes			Yes		
Call Reservation Over Auto TX	N/A			N/A		
Call Reservation Over Manual TX	N/A			N/A		
Quick-Scan (Memory transmission)	Approx. 2.5 sec./page (A4, Standard Resolution)			Approx. 2.5 sec./page (A4, Standard Resolution)		

	ALL-FB1			ALL-FB2		
	US/Canada	Europe	Asia/Pacific	US/Canada	Europe	Asia/Pacific
Model Name	MFC-7420			MFC-7820N		
FAX						
Memory Transmission (ITU-T Chart)	up to 400 pages (ITU-T Test Chart, Standard Resolution, MMR) up to 500 pages ((Brother #1Chart, Standard Resolution, MMR)			up to 500 pages (ITU-T Test Chart, Standard Resolution, JBIG) up to 600 pages ((Brother #1Chart, Standard Resolution, JBIG)		
ECM (Error Correction Mode)	Yes			Yes		
Error Re-Transmission	Yes			Yes		
Broadcasting	Yes (258 locations)			Yes (258 locations)		
Manual Broadcasting	Yes (50 locations)			Yes (50 locations)		
Easy Receive/Fax Detect	Yes			Yes		
Polling Receiving	Yes			Yes		
Auto Reduction	Yes			Yes		
Duplex Fax Receive	N/A			N/A		
Out-of-Paper Reception (ITU-T Chart)	up to 400 pages (ITU-T Test Chart, Standard Resolution, MMR) up to 500 pages ((Brother #1Chart, Standard Resolution, MMR)			up to 500 pages (ITU-T Test Chart, Standard Resolution, JBIG) up to 600 pages ((Brother #1Chart, Standard Resolution, JBIG)		
PC Fax	Yes (Send & Receive)			Yes (Send & Receive)		
LIST/REPORT						
Activity Report/Journal Report	Yes (up to 200)			Yes (up to 200)		
Transmission Verification Report	Yes			Yes		
Cover page	Yes (Super)			Yes (Super)		
Help List	Yes			Yes		
Call Back Message	N/A			N/A		
Caller ID List	Yes	N/A	Yes (ARL/NZ/SIN/ HK only)	Yes	N/A	Yes (ARL/NZ/SIN/ HK only)
Quick Dial List	Yes			Yes		
Tel Index List	N/A			N/A		
Memory Status List	N/A			N/A		
System Setup (User Setting) List	Yes			Yes		
Order Form	N/A	Yes		N/A	Yes	
INTERFACE						
External TAD Interface	Yes			Yes		
Host Interface (Serial)	N/A			N/A		
Host Interface (IEEE1284)	Yes (Auto Switching : IEEE1284/USB)			Yes (Auto Switching : IEEE1284/USB/ 10/100Base-TX)		
Host Interface (Full-Speed USB2.0)	Yes (Auto Switching : IEEE1284/USB)			Yes (Auto Switching : IEEE1284/USB/ 10/100Base-TX)		
Ether Net (10/100base-TX)	N/A			Standard (Auto Switching : IEEE1284/USB/ 10/100Base-TX)		

	ALL-FB1			ALL-FB2		
	US/Canada	Europe	Asia/Pacific	US/Canada	Europe	Asia/Pacific
Model Name	MFC-7420			MFC-7820N		
INTERFACE						
Cable included	N/A			N/A		
Acceptable Media Card Slot	N/A			N/A		
PRINTER						
Color/Mono	Mono			Mono		
Engine Type	Laser (ALL)			Laser (ALL)		
Resolution	HQ1200 (2400x600dpi)			HQ1200 (2400x600dpi)		
Speed(ppm)	up to 20ppm (Letter size)	up to 20ppm (A4 size)		up to 20ppm (Letter size)	up to 20ppm (A4 size)	
Duplex Printing Speed (ppm)	N/A			N/A		
First Print Out Time	Less than 10secs			Less than 10secs		
Standard Print Language	Windows GDI			Windows GDI		
Emulation	N/A			PCL6 & BR-Script 3		
Secure Print	N/A			N/A		
Resident Fonts	N/A			PCL : Bitmap font:Letter Gothic 16.66, OCR-A, OCR-B, Scalable font: 49 fonts PS : PS compatible font : 66 fonts		
Fonts Disk Based	Yes (35 True type Fonts)			Yes (35 True type Fonts)		
Paper Handling Size	LTR, LGL, A4, B5, A5, B6, A6, EXE	LTR, A4, B5, A5, B6, A6, EXE	LTR, LGL, A4, B5, A5, B6, A6, EXE	LTR, LGL, A4, B5, A5, B6, A6, EXE	LTR, A4, B5, A5, B6, A6, EXE	LTR, LGL, A4, B5, A5, B6, A6, EXE
Manual Feed Slot	Custom Size (2.75x4.56 - 8.5x16)			Custom Size (2.75x4.56 - 8.5x16)		
	Envelope (DL/C5/CM10/Monarch)			Envelope (DL/C5/CM10/Monarch)		
Paper Type	Plain Paper, Recycled Paper, Transparency, Envelopes, Bond paper, Labels			Plain Paper, Recycled Paper, Transparency, Envelopes, Bond paper, Labels		
Sheet Weight (Paper Cassette)	60 - 105 g/m2 (16 - 28 lb)			60 - 105 g/m2 (16 - 28 lb)		
(Manual Feed Slot)	60 -161 g/m2 (16 - 43 lb)			60 -161 g/m2 (16 - 43 lb)		
(ADF)	64 - 90 g/m2 (17 - 24 lb)			64 - 90 g/m2 (17 - 24 lb)		
Utility Software	N/A			Yes (Remote Printer Console for PCL6)		
Variable Dot Print	N/A			N/A		
Shingling Print	N/A			N/A		
Color Enhancement	N/A			N/A		
COPY						
Color	N/A			N/A		
Speed	up to 20ppm (Letter size)	up to 20ppm (A4 size)		up to 20ppm (Letter size)	up to 20ppm (A4 size)	
First Copy Out Time (from READY mode *2)	Less than 12 sec			Less than 12 sec		
Multi Copy(Stack)	Yes (up to 99)			Yes (up to 99)		

	ALL-FB1			ALL-FB2		
	US/Canada	Europe	Asia/Pacific	US/Canada	Europe	Asia/Pacific
Model Name	MFC-7420			MFC-7820N		
COPY						
Resolution(dpi)	600 x 300 dpi			600 x 300 dpi		
Manual Duplex Copy	N/A			N/A		
N in 1	Yes			Yes		
Poster	Yes			Yes		
Image Enhancement	N/A			N/A		
SCANNER						
Color/Mono	Color			Color		
Resolution (Hardware)	600 x 2400 dpi			600 x 2400 dpi		
Resolution (Interpolated)	9600 x 9600 dpi			9600 x 9600 dpi		
Gray Scale	256			256		
Color Depth (Int. / Ext.)	24 bit / 24 bit			24 bit / 24 bit		
Scan Key	Yes			Yes		
Scan Image Key	N/A			N/A		
Scan / OCR Key	N/A			N/A		
Scan to E-mail Key	N/A			N/A		
MESSAGE CENTER/MESSAGE MANAGER						
TAD Type	N/A			N/A		
ICM Recording Time	N/A			N/A		
OGM (MC;MC Pro;Paging;F/T)	N/A			N/A		
Memo/Recording Conversation	N/A			N/A		
Toll Saver	N/A			N/A		
Remote Access	Yes			Yes		
Fax Retrieval	Yes			Yes		
Fax Forwarding	Yes			Yes		
Paging	Yes	N/A		Yes	N/A	
BUNDLED SOFTWARE (For Windows)						
Printer Driver	Yes			Yes		
TWAIN (WIA for XP)	Yes			Yes		
Viewer (PaperPort 9.0)	Yes			Yes		
Control Center	Yes			Yes		
PC Fax Send : Fax Share Software by Brother	Yes			Yes		
PC Fax Receive (Parallel & USB only)	Yes			Yes		
Remote Setup	Yes (USB/Parallel only)			Yes (USB/Parallel only)		
BRAdmin Professional (*5)	Yes			Yes		

	ALL-FB1			ALL-FB2		
	US/Canada	Europe	Asia/Pacific	US/Canada	Europe	Asia/Pacific
Model Name	MFC-7420			MFC-7820N		
BUNDLED SOFTWARE (For Windows)						
WebBRAAdmin (*5)	Yes (Download from Web Site)			Yes (Download from Web Site)		
Network Print Software(LPR) (*5)	Yes			Yes		
Network Print Software (NetBIOS/SMTP)	N/A			N/A		
Support OS version	98/98SE/Me/2000/XP, Win NT4.0WS Driver with Auto Installer Program			98/98SE/Me/2000/XP, Win NT4.0WS Driver with Auto Installer Program		
BUNDLED SOFTWARE (For MAC)						
Printer Driver	Yes			Yes		
TWAIN	Yes			Yes		
Viewer (PageManager)	Yes			Yes		
Control Center	Yes			Yes		
PC Fax (Sending only by Brother)	Yes			Yes		
PC FAX Receive	N/A			N/A		
Remote Setup	Yes (for Mac OS X and USB only)			Yes (for Mac OS X and USB only)		
Support OS version	Mac OS 9.1 - 9.2, Mac OS X 10.2.4 or greater			Mac OS 9.1 - 9.2, Mac OS X 10.2.4 or greater		
PHOTO CAPTURE CENTER	N/A			N/A		
Standard NETWORK						
Share Printer	N/A			Yes		
Share Scanner	N/A			Yes		
Share PC FAX (Send)	N/A			Yes		
Internet FAX (ITU T.37 simple mode)	N/A			(SST Only)		
Scan to E-mail server	N/A			(SST Only)		
ITU SUB Addressing	N/A			N/A		
Support OS version for PC client	N/A			Win98/98SE/Me/2K/XP, Win NT4.0WS Mac OS 9.1 - 9.2, Mac OS X 10.2.4 or greater (Simple Network Configuration is supported with OS 10.2.4 or greater)		
Network connection	N/A			Ethernet 10/100BASE-TX Auto Negotiation		
Support Protocols	N/A			TCP/IP TELNET, SNMP, HTTP, TFTP, ARP,RARP, BOOTP, DHCP, APIPA (Auto IP), WINS/NetBIOS, DNS, LPR/LPD, Custom Raw Port/Port9100, POP3/SMTP, IPP, FTP, mDNS		
Network Management	N/A			BRAdmin Professional Web Based Management MIB-II as well as Brother private MIB		

	ALL-FB1			ALL-FB2		
	US/Canada	Europe	Asia/Pacific	US/Canada	Europe	Asia/Pacific
Model Name	MFC-7420			MFC-7820N		
Optional NETWORK (*6)						
Model Name	NC-2100P (Parallel external print server) / NC-2200w (Wireless USB server)			NC-2100P (Parallel external print server) / NC-2200w (Wireless USB server)		
Share Printer	NC-2100 : Yes / NC-2200w : Yes			NC-2100 : Yes / NC-2200w : Yes		
Share Scanner	NC-2100 : No / NC-2200w : Yes			NC-2100 : No / NC-2200w : Yes		
Share PC FAX (Send)	NC-2100 : No / NC-2200w : Yes			NC-2100 : No / NC-2200w : Yes		
ACCESSORY						
Life / Yield	(Toner : Approx. 2,500 pages)			(Toner : Approx. 2,500 pages)		
	(Drum : 12,000 pages: 1 page/job)			(Drum : 12,000 pages: 1 page/job)		

DCP7010/7020/7025

(9/15)

	ALL-DCP1			ALL-DCP2
	US/Canada	Europe	Asia/Pacific	Europe
Model Name	DCP-7020	DCP-7010		DCP-7025
GENERAL				
Print Engine	Laser (ALL)			Laser (ALL)
CPU Speed	SparcLite 133MHz			SparcLite 133MHz
Back up Clock	N/A			N/A
Operating Environment Temperature	10 - 32.5 degrees Centigrade			10 - 32.5 degrees Centigrade
Operating Environment Humidity	20% - 80% (without condensation)			20% - 80% (without condensation)
On/Off Switch	Yes			Yes
AC Cord inlet	Yes			Yes
Demo Print	Yes (US only)	N/A		N/A
Demo Model	N/A			N/A
Starter Toner	Starter	Full		Full
Simultaneous Operation	Yes			Yes
Input / Output Width	5.8"-8.5" / 2.75"-8.5" 147.3-215.9 mm / 69.9-215.9 mm			5.8"-8.5" / 2.75"-8.5" 147.3-215.9 mm / 69.9-215.9 mm
Input / Output Length	5.8"-14" / 4.56"-16" 147.3-356.0 mm/ 116.0-406.4 mm			5.8"-14" / 4.56"-16" 147.3-356.0 mm/ 116.0-406.4 mm
ADF	up to 35 sheets	N/A		up to 35 sheets
Paper Capacity	250 sheets			250 sheets
Optional Paper Tray	N/A			N/A
Multi-Purpose Tray	N/A			N/A
Output Paper Capacity (sheets)	up to 100 sheets			up to 100 sheets
Lower Tray - Automatic Detection	N/A			N/A
LCD Size	16 characters x 2 lines			16 characters x 2 lines
LCD Back-Lit	N/A			Yes (1-color)
On-Screen Programming	Yes			Yes
Memory Capacity (Standard : MByte)	16 Mbyte (RAM)			32 Mbyte (RAM)
Memory Backup	N/A			N/A
Optional Memory	N/A			N/A
Memory Security	N/A			N/A
Transmission Lock	N/A			N/A
Setting Lock	N/A			N/A
Dimensions w/ Carton (WxDxH)	550mm x 495mm x 500mm	550mm x 495mm x 450mm		550mm x 495mm x 500mm
Dimensions w/o Carton (WxDxH)	432mm x 395mm x 294mm			432mm x 395mm x 294mm
Weight w/ Carton	13.6kg	12.3kg		13.6kg
Weight w/o Carton	9.45kg	8.3kg		9.45kg
Color	Front/Top cover: 1581 gray, Side cover: 1736 gray			Front/Top cover: 1581 gray, Side cover: 1736 gray

	ALL-DCP1			ALL-DCP2
	US/Canada	Europe	Asia/Pacific	Europe
Model Name	DCP-7020	DCP-7010		DCP-7025
GENERAL				
Power Source	120V AC 50/60 (Canada)Hz	220-240V AC 50/60Hz		220-240V AC 50/60Hz
Power Consumption (Copying)	460W			460W
Power Consumption (Sleep/Standby/Peak)	10W/75W/1032W			10W/75W/1032W
Power Save (CPU Sleep)	N/A			N/A
Sleep Mode (00-99min : w/ OFF mode)	Yes			Yes
Energy Star Compliant (USA Only)	Yes	N/A		N/A
Total Print pages Counter (Internal / LCD / Print)	Yes / Yes/ Yes			Yes / Yes/ Yes
Copy pages Counter (Internal / LCD / Print)	Yes / Yes/ Yes			Yes / Yes/ Yes
PC print pages Counter (Internal / LCD / Print)	Yes / Yes/ Yes			Yes / Yes/ Yes
Fax RX pages counter (Internal / LCD / Print)	N/A			N/A
Warm up Time (from SLEEP mode)	Max. 18 sec. at 73.4 F (23C)			Max. 18 sec. at 73.4 F (23C)
Paper Type(Media) Setting	Yes			Yes
TELEPHONE				
Handset	N/A			N/A
Off Hook Alarm	N/A			N/A
Power Failure Phone	N/A			N/A
Power Failure Dialing	N/A			N/A
Chain Dialing	N/A			N/A
Automatic Redial	N/A			N/A
PBX Feature	N/A			N/A
Speaker Phone	N/A			N/A
Handset Volume	N/A			N/A
Speaker Volume	N/A			N/A
Buzzer Volume	Yes (3 steps + OFF)			Yes (3 steps + OFF)
Ring Volume	N/A			N/A
Hold/Mute Key	N/A			N/A
Music on Hold	N/A			N/A
Monitoring the Line on Hold with Music	N/A			N/A
One-Touch Dial	N/A			N/A
Speed Dial	N/A			N/A
Figures of One-Touch & Speed Dial	N/A			N/A

	ALL-DCP1			ALL-DCP2
	US/Canada	Europe	Asia/Pacific	Europe
Model Name	DCP-7020	DCP-7010		DCP-7025
TELEPHONE				
Telephone Index (Search)		N/A		N/A
Pre-registered for FAX BACK SYSTEM (USA)		N/A		N/A
Caller ID		N/A		N/A
Call Waiting Caller ID		N/A		N/A
Call waiting Ready (Only for USA)		N/A		N/A
Distinctive Ringing		N/A		N/A
FAX				
		N / A		N / A
Modem Speed		-		-
Transmission Speed		-		-
ITU-T Group		-		-
Coding Method		-		-
Color FAX (Document Send / Receive)		-		-
Color FAX (Memory Send / Receive)		-		-
Fax/Tel Switch		-		-
Super Fine		-		-
Gray Scale		-		-
Contrast		-		-
Smoothing		-		-
Dual Access		-		-
Enhanced Remote Activate		-		-
Station ID		-		-
Remote Maintenance		-		-
RX Mode Indication		-		-
Resolution Indication		-		-
Delayed Timer		-		-
Polled Sending		-		-
Multi Transmission		-		-
Multi Resolution Transmission		-		-
Next-Fax Reservation		-		-
Batch Transmission		-		-
Call Reservation Over Auto TX		-		-
Call Reservation Over Manual TX		-		-
Quick-Scan (Memory transmission)		-		-
Memory Transmission (ITU-T Chart)		-		-
ECM (Error Correction Mode)		-		-
Error Re-Transmission		-		-
Broadcasting		-		-

	ALL-DCP1			ALL-DCP2
	US/Canada	Europe	Asia/Pacific	Europe
Model Name	DCP-7020	DCP-7010		DCP-7025
FAX	N / A			N / A
Polling Receiving	-			-
Auto Reduction	-			-
Duplex Fax Receive	-			-
Out-of-Paper Reception (ITU-T Chart)	-			-
PC Fax	-			-
LIST/REPORT				
Activity Report/Journal Report	-			-
Transmission Verification Report	-			-
Cover page	-			-
Help List	-			-
Call Back Message	-			-
Caller ID List	-			-
Quick Dial List	-			-
Tel Index List	-			-
Memory Status List	-			-
System Setup (User Setting) List	YES			YES
Order Form	N/A			N/A
INTERFACE				
External TAD Interface	N/A			N/A
Host Interface (Serial)	N/A			N/A
Host Interface (IEEE1284)	Yes (Auto Switching : IEEE1284/USB)			Yes (Auto Switching : IEEE1284/USB)
Host Interface (Full-Speed USB2.0)	Yes (Auto Switching : IEEE1284/USB)			Yes (Auto Switching : IEEE1284/USB)
Ether Net (10/100base-TX)	N/A			N/A
Cable included	N/A			N/A
Acceptable Media Card Slot	N/A			N/A
PRINTER				
Color/Mono	Mono			Mono
Engine Type	Laser (ALL)			Laser (ALL)
Resolution	HQ1200 (2400x600dpi)			HQ1200 (2400x600dpi)
Speed(ppm)	up to 20ppm (Letter size)	up to 20ppm (A4 size)		up to 20ppm (A4 size)
Duplex Printing Speed (ppm)	N/A			N/A
First Print Out Time	Less than 10secs			Less than 10secs
Standard Print Language	Windows GDI			Windows GDI
Emulation	N/A			PCL6 & BR-Script 3
Secure Print	N/A			N/A
Resident Fonts	N/A			PCL : Bitmap font:Letter Gothic 16.66, OCR-A, OCR-B, Scalable font: 49 fonts PS : PS compatible font : 66 fonts

	ALL-DCP1			ALL-DCP2
	US/Canada	Europe	Asia/Pacific	Europe
Model Name	DCP-7020	DCP-7010		DCP-7025
PRINTER				
Fonts Disk Based	Yes (35 True type Fonts)			Yes (35 True type Fonts)
Paper Handling Size	LTR, LGL, A4, B5, A5, B6, A6, EXE	LTR, A4, B5, A5, B6, A6, EXE	LTR, LGL, A4, B5, A5, B6, A6, EXE	LTR, A4, B5, A5, B6, A6, EXE
Manual Feed Slot	Custom Size (2.75x4.56 - 8.5x16)			Custom Size (2.75x4.56 - 8.5x16)
	Envelope (DL/C5/CM10/Monarch)			Envelope (DL/C5/CM10/Monarch)
Paper Type	Plain Paper, Recycled Paper, Transparency, Envelopes, Bond paper, Labels			Plain Paper, Recycled Paper, Transparency, Envelopes, Bond paper, Labels
Sheet Weight (Paper Cassette)	60 - 105 g/m2 (16 - 28 lb)			60 - 105 g/m2 (16 - 28 lb)
(Manual Feed Slot)	60 - 161 g/m2 (16 - 43 lb)			60 - 161 g/m2 (16 - 43 lb)
(ADF)	64 - 90 g/m2 (17 - 24 lb)			64 - 90 g/m2 (17 - 24 lb)
Utility Software	N/A			Yes (Remote Printer Console for PCL6)
Variable Dot Print	N/A			N/A
Shingling Print	N/A			N/A
Color Enhancement	N/A			N/A
COPY				
Color	N/A			N/A
Speed	up to 20ppm (Letter size)	up to 20ppm (A4 size)		up to 20ppm (A4 size)
First Copy Out Time (from READY mode *2)	Less than 12 sec			Less than 12 sec
Multi Copy(Stack)	Yes (up to 99)			Yes (up to 99)
Multi Copy(Sort)	Yes			Yes
Reduction/Enlargement(%)	25% - 400% in 1% increments			25% - 400% in 1% increments
Resolution(dpi)	600 x 300 dpi			600 x 300 dpi
Manual Duplex Copy	N/A			N/A
N in 1	Yes			Yes
Poster	Yes			Yes
Image Enhancement	N/A			N/A
SCANNER				
Color/Mono	Color			Color
Resolution (Hardware)	600 x 2400 dpi			600 x 2400 dpi
Resolution (Interpolated)	9600 x 9600 dpi			9600 x 9600 dpi
Gray Scale	256			256
Color Depth (Int. / Ext.)	24 bit / 24 bit			24 bit / 24 bit
Scan Key	Yes			Yes
Scan Image Key	N/A			N/A
Scan / OCR Key	N/A			N/A

	ALL-DCP1			ALL-DCP2
	US/Canada	Europe	Asia/Pacific	Europe
Model Name	DCP-7020	DCP-7010		DCP-7025
MESSAGE CENTER/MESSAGE MANAGER				
TAD Type	N/A		N/A	
ICM Recording Time	N/A		N/A	
OGM (MC;MC Pro;Paging;F/T)	N/A		N/A	
Memo/Recording Conversation	N/A		N/A	
Toll Saver	N/A		N/A	
Remote Access	N/A		N/A	
Fax Retrieval	N/A		N/A	
Fax Forwarding	N/A		N/A	
Paging	N/A		N/A	
BUNDLED SOFTWARE (For Windows)				
Printer Driver	Yes		Yes	
TWAIN (WIA for XP)	Yes		Yes	
Viewer (PaperPort 9.0)	Yes		Yes	
Control Center	Yes		Yes	
PC Fax Send : Fax Share Software by Brother	N/A		N/A	
PC Fax Receive (Parallel & USB only)	N/A		N/A	
Remote Setup	N/A		N/A	
BRAdmin Professional (*5)	Yes		Yes	
WebBRAdmin (*5)	Yes (Download from Web Site)		Yes (Download from Web Site)	
Network Print Software(LPR) (*5)	Yes		Yes	
Network Print Software (NetBIOS/SMB)	N/A		N/A	
Support OS version	98/98SE/Me/2000/XP, Win NT4.0WS Driver with Auto Installer Program		98/98SE/Me/2000/XP, Win NT4.0WS Driver with Auto Installer Program	
BUNDLED SOFTWARE (For MAC)				
Printer Driver	Yes		Yes	
TWAIN	Yes		Yes	
Viewer (PageManager)	Yes		Yes	
Control Center	Yes		Yes	
PC Fax (Sending only by Brother)	N/A		N/A	
PC FAX Receive	N/A		N/A	
Remote Setup	N/A		N/A	
Support OS version	Mac OS 9.1 - 9.2, Mac OS X 10.2.4 or greater		Mac OS 9.1 - 9.2, Mac OS X 10.2.4 or greater	

	ALL-DCP1			ALL-DCP2
	US/Canada	Europe	Asia/Pacific	Europe
<i>Model Name</i>	DCP-7020	DCP-7010		DCP-7025
<i>PHOTO CAPTURE CENTER</i>	N/A			N/A
Standard NETWORK				
Share Printer	N/A			N/A
Share Scanner	N/A			N/A
Share PC FAX (Send)	N/A			N/A
Internet FAX (ITU T.37 simple mode)	N/A			N/A
Scan to E-mail server	N/A			N/A
ITU SUB Addressing	N/A			N/A
Support OS version for PC client	N/A			N/A
Network connection	N/A			N/A
Support Protocols	N/A			N/A
Network Management	N/A			N/A
Optional NETWORK (*6)				
Model Name	NC-2100P (Parallel external print server) / NC-2200w (Wireless USB server)		NC-2100P (Parallel external print server) / NC-2200w (Wireless USB server)	
Share Printer	NC-2100 : Yes / NC-2200w : Yes		NC-2100 : Yes / NC-2200w : Yes	
Share Scanner	NC-2100 : No / NC-2200w : Yes		NC-2100 : No / NC-2200w : Yes	
Share PC FAX (Send)	N/A			N/A
ACCESSORY				
Life / Yield	(Toner : Approx. 2,500 pages)			(Toner : Approx. 2,500 pages)
	(Drum : 12,000 pages: 1 page/job)			(Drum : 12,000 pages: 1 page/job)

CHAPTER 3

THEORY OF OPERATION

Confidential

CHAPTER 3 THEORY OF OPERATION

This chapter gives an overview of the scanning and printing mechanisms as well as the sensors, actuators, and control electronics. It aids in understanding the basic principles of operation as well as locating defects for troubleshooting.

CONTENTS

3.1	OVERVIEW	3-1
3.2	MECHANICAL COMPONENTS.....	3-2
3.2.1	Scanner Mechanism	3-3
3.2.2	Printing Mechanism.....	3-6
3.2.2.1	Paper supply	3-6
3.2.2.2	Push-up function of paper tray.....	3-8
3.2.2.3	Paper registration.....	3-10
3.2.2.4	Paper eject.....	3-11
3.2.2.5	Drum unit.....	3-11
3.2.2.6	Toner cartridge.....	3-12
3.2.2.7	Print process	3-15
3.2.3	Sensors and Actuators.....	3-18
3.3	CONTROL ELECTRONICS.....	3-19
3.3.1	Components.....	3-19

Confidential

3.1 OVERVIEW

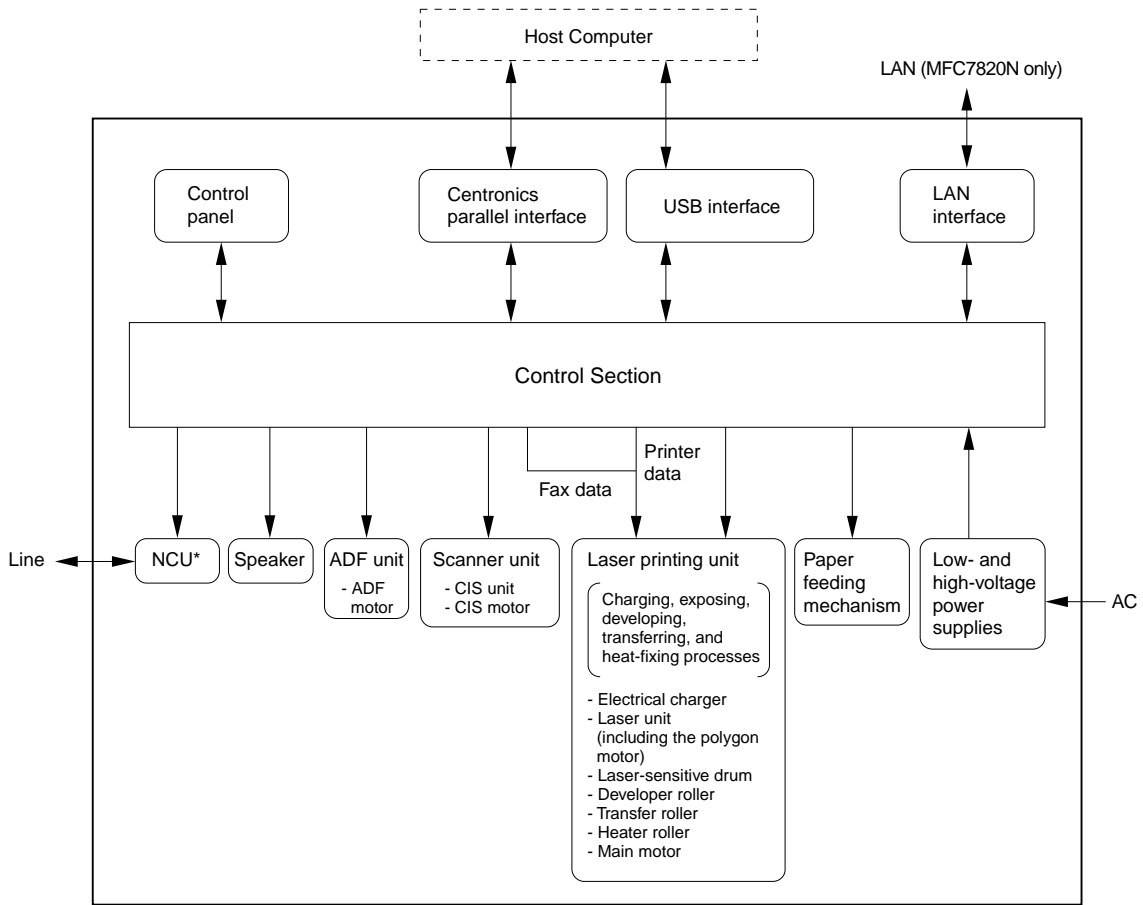

*Provided on models supporting facsimile function.

3.2 MECHANICAL COMPONENTS

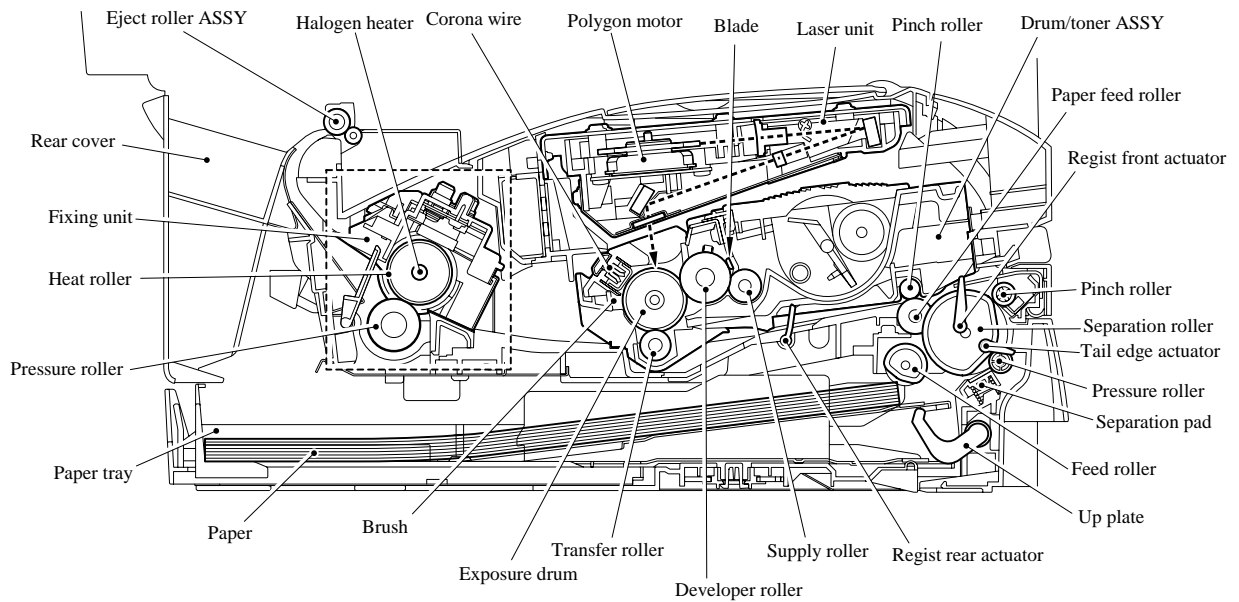

3.2.1 Scanner Mechanism

This mechanism consists of the document cover, the scanner unit (scanner cover), and the automatic document feeder (ADF).

The scanner unit consists of a scanner top cover, CIS unit, CIS drive assembly, and scanner base.

The detailed illustration on the next page shows the components making up the ADF: document pull-in roller, document separation roller, document feed roller, ADF motor, and document front and rear sensors.

For further details on the sensors, see [Section 3.2.3](#).

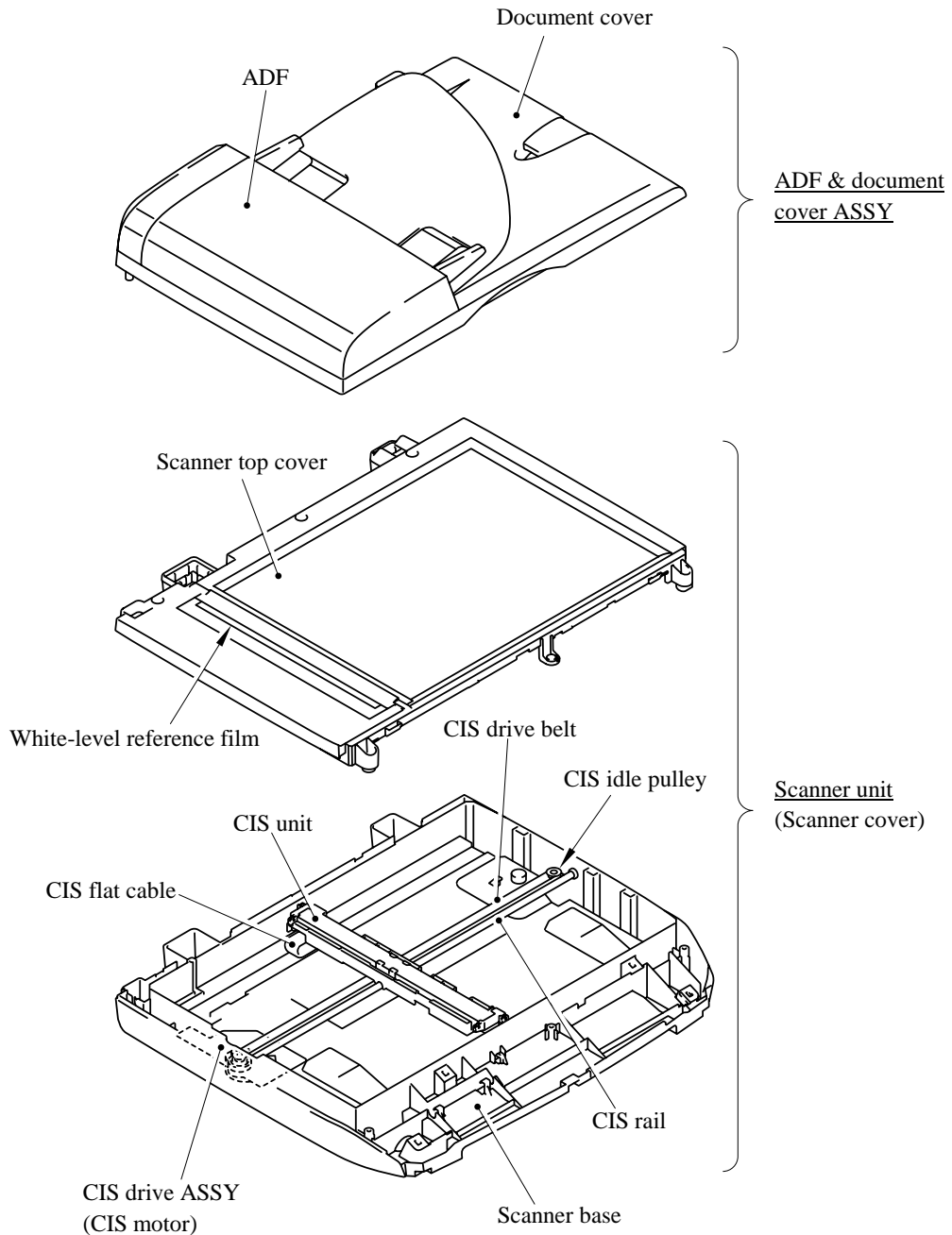

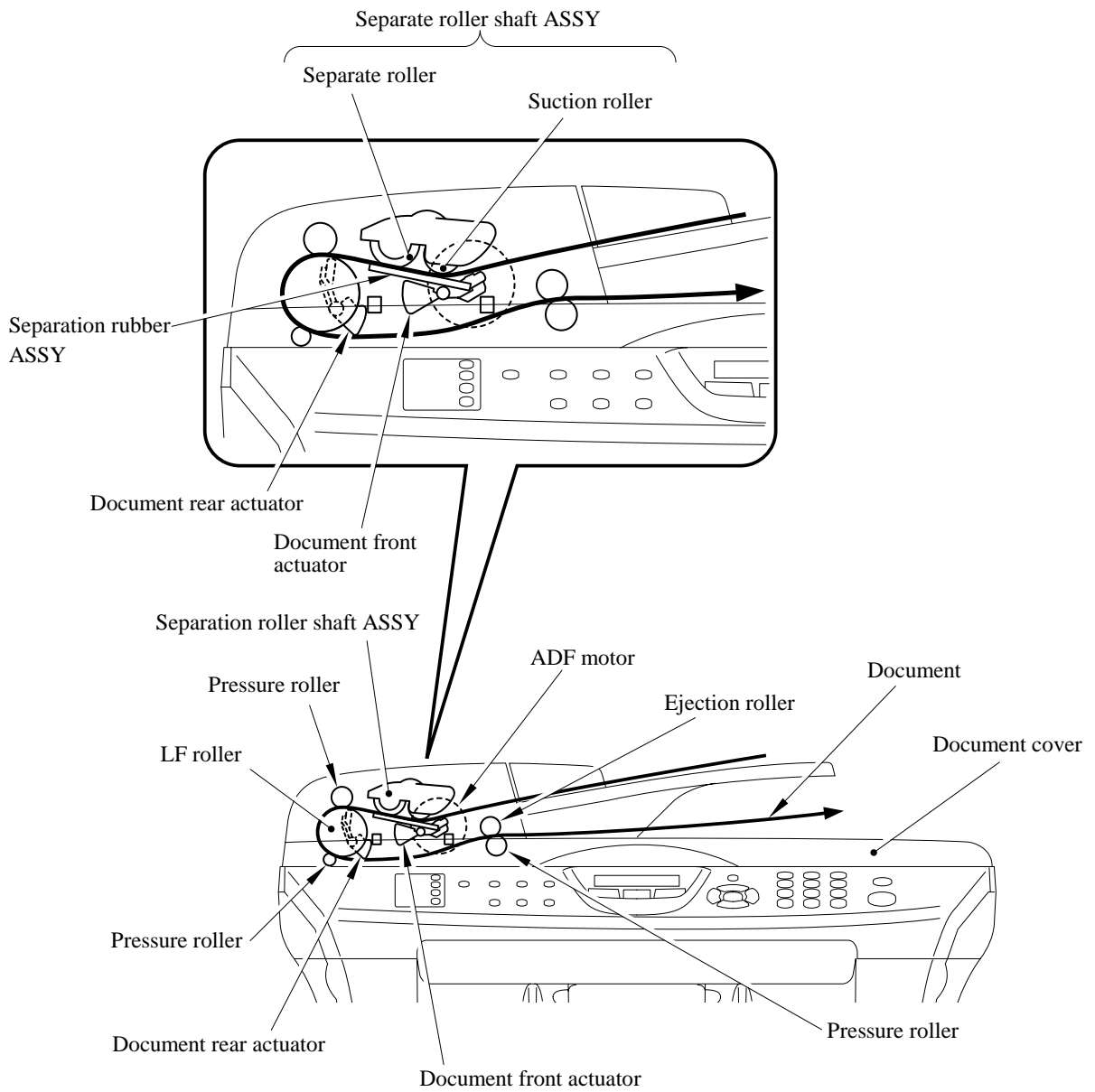

This scanner mechanism supports a dual scanning system: ADF scanning and flat-bed scanning. They automatically switch to the former at the start of a scan operation if the document front sensor inside the ADF detects a document.

(1) ADF scanning: Document moves across stationary CIS unit

Placing a document **face up** in the document support activates the document front sensor, switching to ADF scanning.

The CIS drive mechanism (details below) operates for each scanning command executed. The CIS unit first moves to the white-level reference film for white level compensation and then to the ADF scanning position.

The ADF motor then rotates the document pull-in roller to pull the document into the ADF.

The document separation roller feeds the pages one at a time, **starting from the top**, to the document feed roller, which rotates to move the page in a curve left, down, and right.

The page is scanned as it passes over the CIS unit. It then leaves the machine **face down** onto the document cover. The machine inserts subsequent pages under this one to preserve the document page order.

(2) Flat-bed scanning: CIS unit moves under stationary document

The user lifts the document cover, places a page (or open book) **face down** on the glass plate, and closes the document cover.

The CIS drive mechanism (details below) operates for each scanning command executed.

The CIS unit first moves to the white-level reference film for white level compensation.

It then moves right, scanning as it goes. It returns to its home position after the scan.

CIS drive mechanism

The contact image sensor (CIS) unit rides along the CIS rail driven by the CIS drive belt. Clockwise motion of the CIS motor moves the unit to the left; counterclockwise motion, to the right. This unit consists of the document illumination LED array, the self-focus lens array gathering the light reflected from the scanned image, the CIS PCB converting the light input to pixel data output, and a glass cover.

The CIS unit is the type in which color reading is possible. While reading the color stationary document, the LED array with red, green, blue (RGB) lights up the 3 colors alternately. While reading the monochrome document, only the green color of the LCD array will be lighten up.

3.2.2 Printing Mechanism

3.2.2.1 Paper supply

The feed roller picks up a few sheets or one sheet of paper from the paper tray every time it is rotated and feeds it to the separation roller.

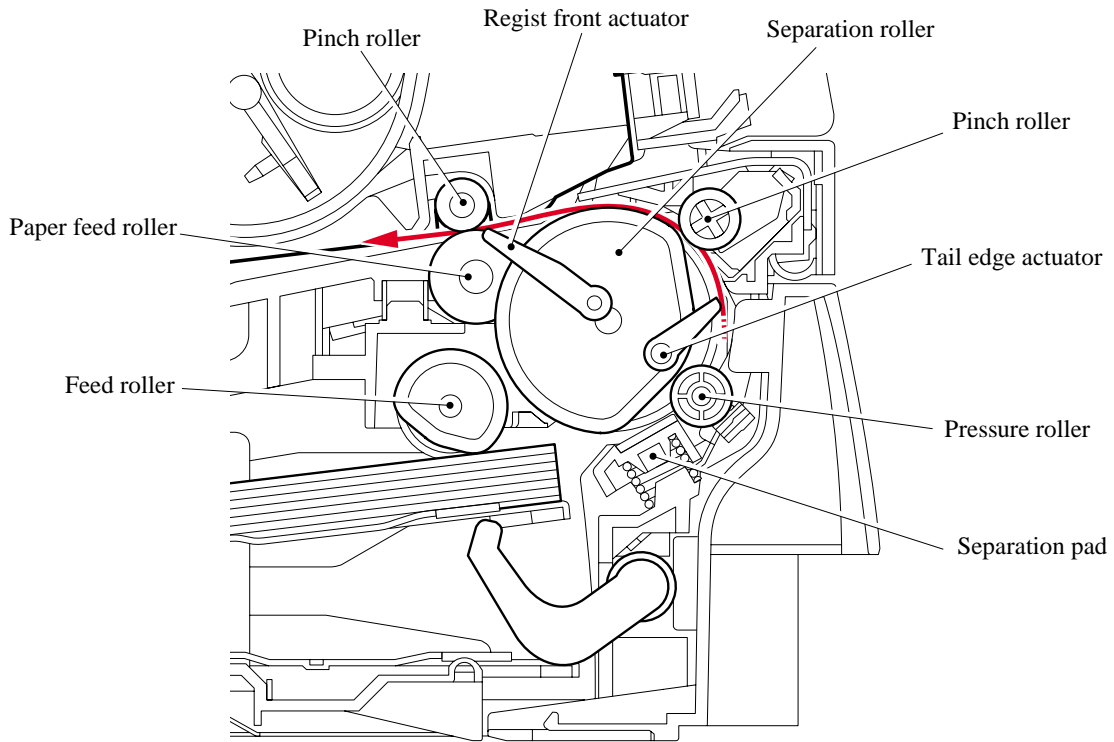

- (1) The paper is gripped between the separation roller and separation pad and separated into individual sheets. The separation roller is connected to the gear 52 P/R.
- (2) The section of the gear 52 P/R, where there is no cog, is normally fixed at the position as shown in the figure below by the P/R solenoid ASSY.
- (3) Therefore, the main motor drive is not transmitted to the gear 52 P/R.
- (4) When the paper is fed, the P/R solenoid ASSY is activated first.
- (5) Then, the gear 52 P/R is pulled by the spring extension P/R so that the gears are engaged.
- (6) The main motor drive is transmitted to the gear 52 P/R, and the separation roller is turned.

The paper drawn out of the paper tray pushes against the regist front actuator, and the paper top position or absence of paper is detected by the actuator movement. The tail edge actuator detects the end of the paper fed.

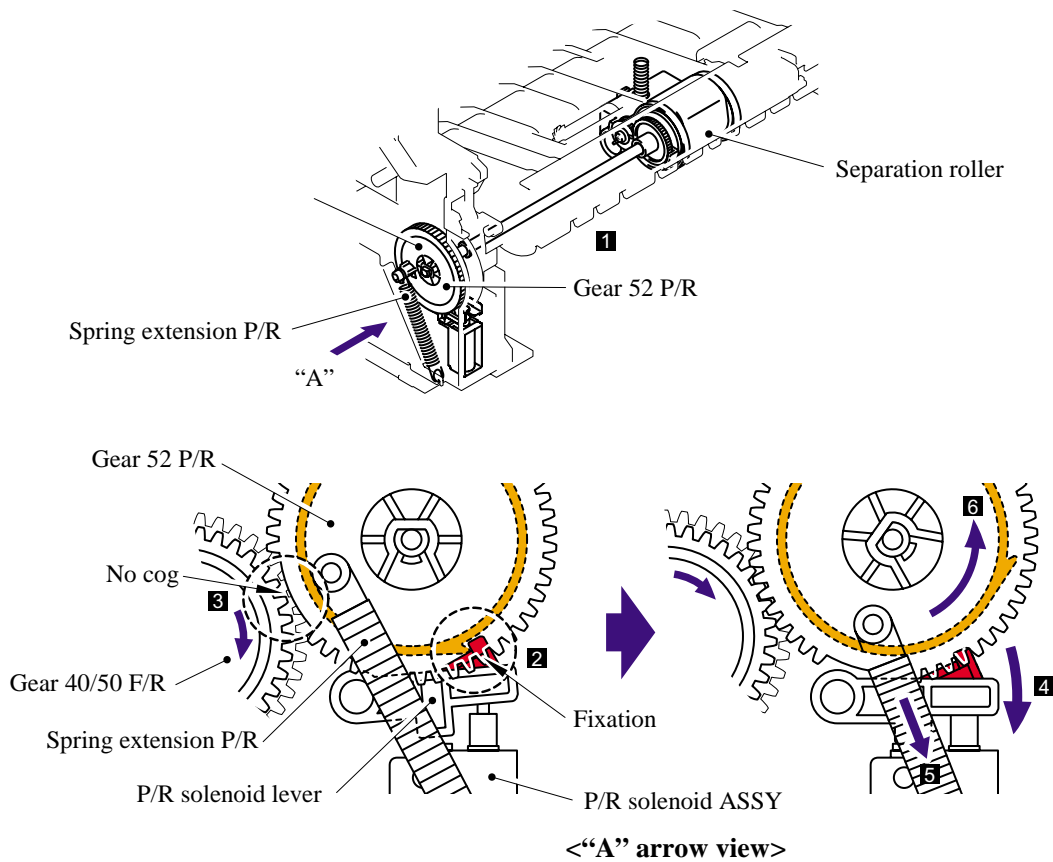

3.2.2.2 Push-up function of paper tray

In order to improve the transfer function of the paper tray, the pressure plate in the paper tray is lifted up by the motor.

- (1) The pressure plate comes down while the recording paper tray is inserted into the machine. When the main motor rotates, it drives through some gears to actuate the gear 45 arm/FR. The driving force that 45 arm/FR received is to be transferred to gear 13 center P/R, it then drives through some gears to gear 17. The gear 17 actuates the up plate gear of the recording paper tray to push up the pressure plate.
- (2) When the pressure plate is pushed up, the paper placed on the pressure plate is contacted with the pick up roller holder ASSY so that the pick up roller holder ASSY is pushed up.
- (3) When the pick up roller holder ASSY is pushed up more, one end of the link lever assembled on the pick up roller holder ASSY is pushed up. Since the center of the link lever is held as a fulcrum, the other end of the link lever comes down.
- (4) The other end of the link lever is contacted with the hook B and hook C so that the hook B is pushed down when the link lever comes down.
- (5) When the hook B is pushed down, the catch of the hook B is released from the lock of the sector cam.
- (6) The sector cam is rotated by approximately three quarters when the catch of the hook B is released.
- (7) Then, the sector cam is stopped rotating by the catch of the hook C. (The hook B and hook C is connected with the spring. When the hook B is pushed down, the hook C is also pushed down, and the catch of the hook C is released from the lock of the sector cam.)
- (8) When the sector cam is fixed at the position of the catch of the hook C, the hook A is lifted up by the sector cam.
- (9) The inside gear of the gear 13 center P/R, which has been fixed, is released.
- (10) When the inside gear of the gear 13 center P/R is released, the central gear of the gear 13 center P/R is stopped rotating. Then, the gear pushing up the pressure plate in the paper tray is stopped so that the pressure plate is stopped lifting up.

The gear 13 center P/R consists of the three gears, and power of the main motor is added onto the outside gear. When the inside gear is fixed while the main motor power being added, the central gear is started rotating. When the fixed inside gear is released, the central gear is stopped, and the inside gear is rotated.

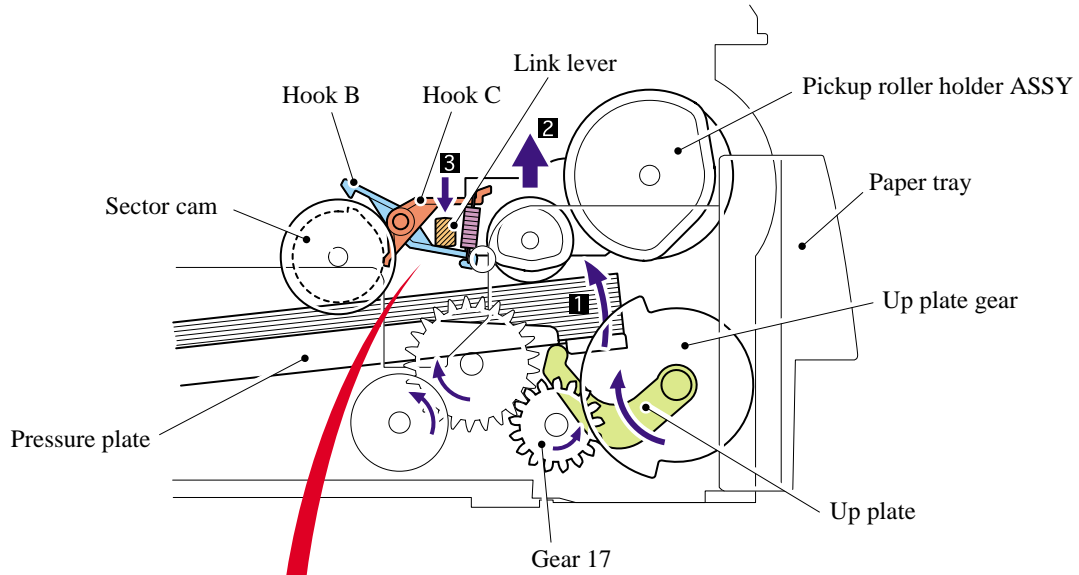

< Table side >

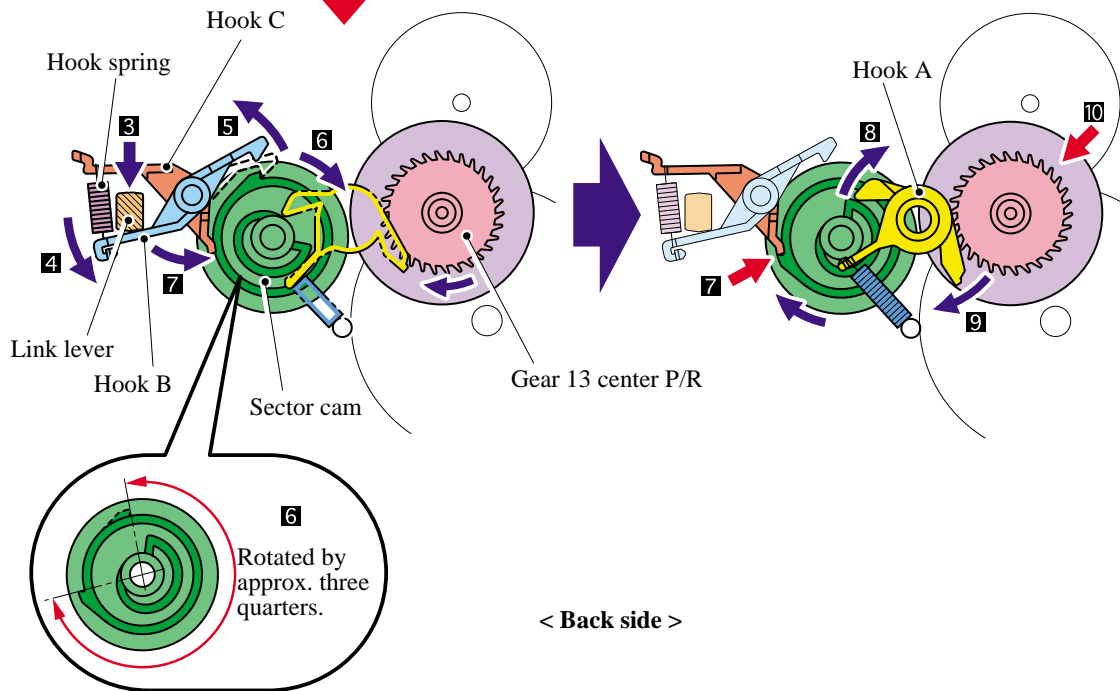

< Back side >

3.2.2.3 Paper registration

After the paper top position is detected by the regist front actuator, the paper, separated into individual sheets by the separation roller, is fed further for a specified time, and the paper top position reaches the paper feed roller so that the paper skew is adjusted. Then, the F/R solenoid is turned off, the paper feed roller starts turning, and the paper is fed to the transfer roller in the drum/toner ASSY.

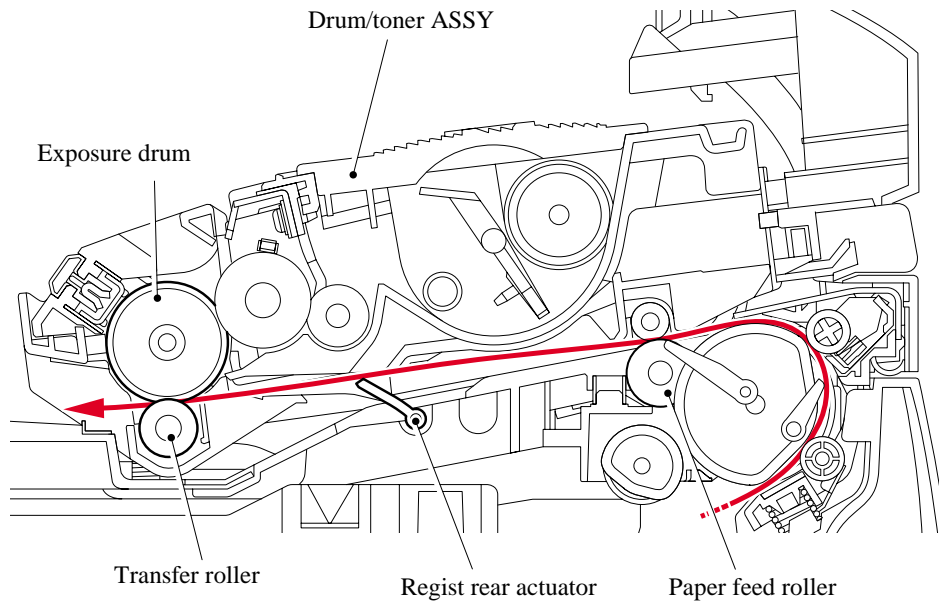

The regist rear actuator in the path from the feed roller to the transfer roller controls the first print position on the paper. The printer starts transferring an image when a definite time passes after the paper is passed through the regist rear actuator.

3.2.2.4 Paper eject

After the printing image on the exposure drum is transferred onto the paper, the paper is fed to the fixing unit to fix unfixed toner onto the paper.

Afterwards, the paper is ejected from the fixing unit by the heat roller and the pressure roller in the fixing unit. The paper eject actuator detects whether the paper is ejected correctly or not.

After the paper exits from the heat roller, the paper is turned by the rear cover and ejected face down into the top output tray through the eject roller ASSY.

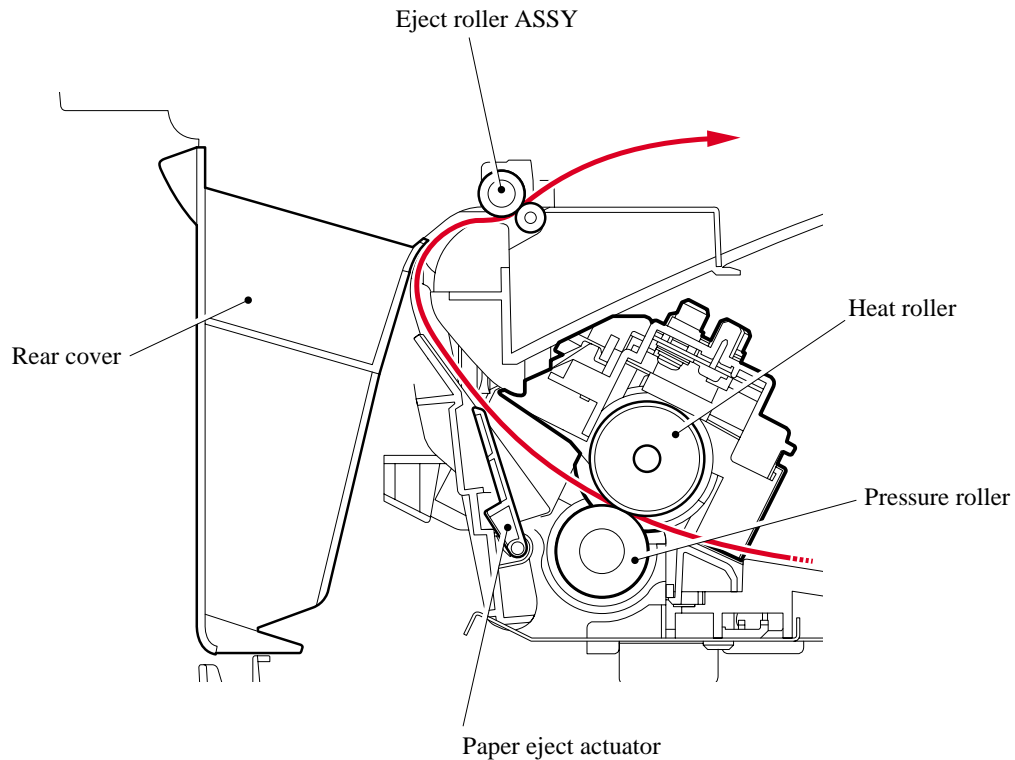

3.2.2.5 Drum unit

■ Exposure drum

Generates the latent electrostatic image and develops the image on the drum surface.

■ Primary charger

Forms a uniform charge on the drum surface.

(1) Corona wire

Generates the ion charge on the drum.

(2) Grid

Spreads the ion charge evenly over the drum surface.

■ Transfer roller

Transfers the toner image to the paper from the drum surface.

■ Cleaner

Removes the paper dust or dirt on the surface of the exposure drum.

3.2.2.6 Toner cartridge

Develops the electrostatic latent image on the exposure drum with toner and forms the visible image.

■ Toner life end mode

The life of the toner cartridge is starter: 1,500, standard: 2,500 pages at the 5% coverage. In the case of low- duty printing, “Toner Life End” is indicated by displaying the ‘Toner Life End’ message on the LCD before toner runs out because the developer roller surface or other toner sealing is worn out due to rotation of the rollers. The upper limit of the drum rotation is 45,000 = 3000 sheets x 15 rotations.

The following graph shows the number of printable pages in the case of A4 printing.

HL-2030/2040/2070N (Standard toner)

Page/job	1	2	3	4	5	6	7	8	9	10	11	12
Cartridge life (Always power on)	3,000	4,663	5,720	6,452	6,988	7,397	7,721	7,982	8,198	8,380	8,534	8,668
Cartridge life (Power ON/OFF per job)	1,957	3,297	4,272	5,014	5,597	6,067	6,455	6,780	7,056	7,293	7,500	7,681
Toner empty (5%)	2,500	2,500	2,500	2,500	2,500	2,500	2,500	2,500	2,500	2,500	2,500	2,500
Toner empty (4%)	3,125	3,125	3,125	3,125	3,125	3,125	3,125	3,125	3,125	3,125	3,125	3,125
Toner empty (3%)	4,167	4,167	4,167	4,167	4,167	4,167	4,167	4,167	4,167	4,167	4,167	4,167
Toner empty (2%)	6,250	6,250	6,250	6,250	6,250	6,250	6,250	6,250	6,250	6,250	6,250	6,250
Toner empty (1%)	12,500	12,500	12,500	12,500	12,500	12,500	12,500	12,500	12,500	12,500	12,500	12,500

$$\text{Cartridge life} = 15a \times 3000 / (4.3 \times (a - 1) + 15)$$

a : Page / job

$$\text{Cartridge life+ON/OFF} = 15a \times 3000 / (4.3 \times (a - 1) + 15 + 8)$$

$$\text{Cartridge life (Mechanical limit)} : 3000 \text{ (1page / job)}$$

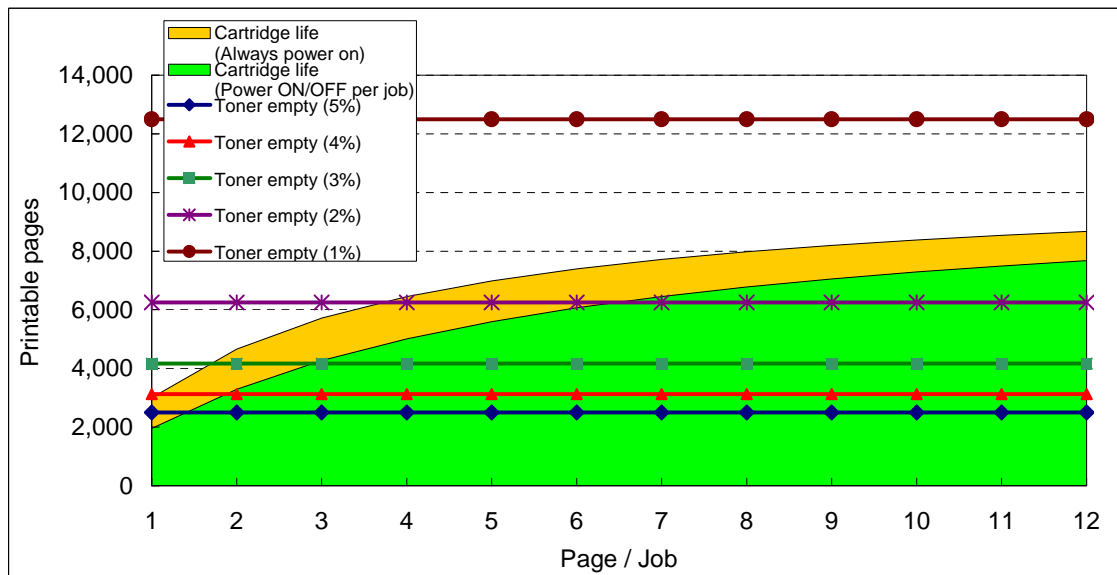

■ New toner detection mechanism

The printer detects the amount of the remaining toner with the sensor and indicates the timing to replace the toner cartridge by displaying 'Toner Life End' on the LCD to the user. The problem such as toner leak or image defect may occur when low-duty printing is continued for a long time. To prevent such a problem, the printer provides the function displaying the 'Toner Low' message on the LCD when the toner is used to a certain degree to indicate it to the user.

When replacing the toner cartridge with a new one, the printer detects that the toner cartridge is replaced with a new one by the new toner detection switch and cancels the message on the LCD.

The mechanism to detect the new toner cartridge is as follows:

- (1) A new toner cartridge is installed into the drum unit, and the drum unit is installed into the printer.
- (2) The reset gear of the toner cartridge is contacted with the new toner actuator to push the new toner actuator.
- (3) Then, the new toner actuator pushes the new toner detection switch so that it is detected that a new toner cartridge is installed.
- (4) When the toner cartridge is installed into the printer, the reset gear is rotated by the main motor drive and moved to the position of "Toner in use".

When the reset gear is moved to the position of "Toner in use", the new toner actuator is pulled back by the new toner actuator spring and returned to the original position. When the reset gear is at the position of "Toner in use", the reset gear is not returned to the original position since the reset gear and drive gear of the main motor are not engaged, and the reset gear is not rotated.

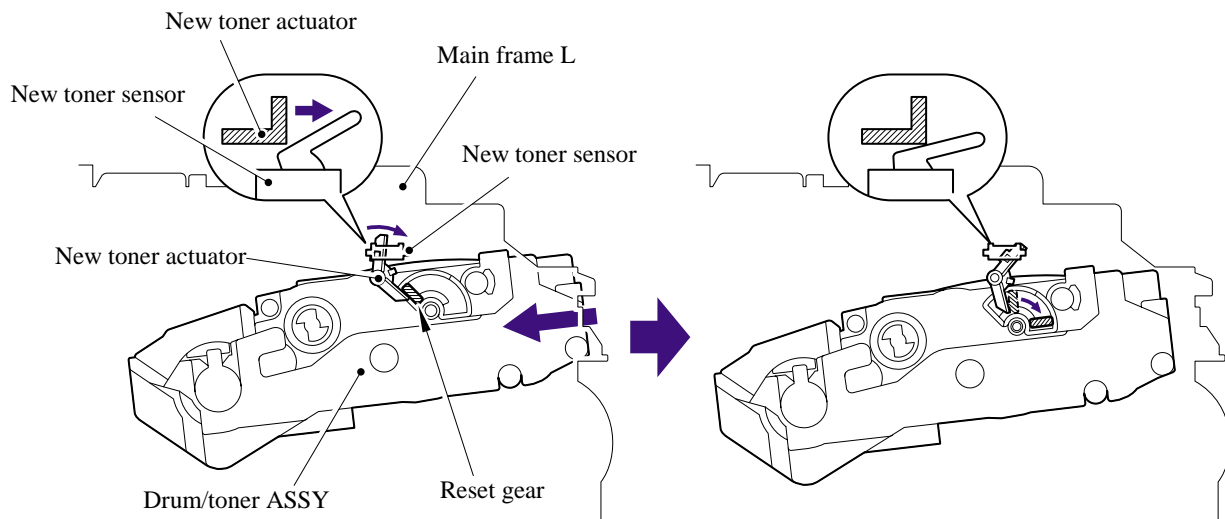

When the new toner detection switch detects that the toner cartridge is replaced with a new one, the developing bias voltage is initialized at the same time.

The toner used for the printer has a property that print density is light first and gradually darker in the course of usage. The developing bias controls the toner property so that the print density is constant from first to last.

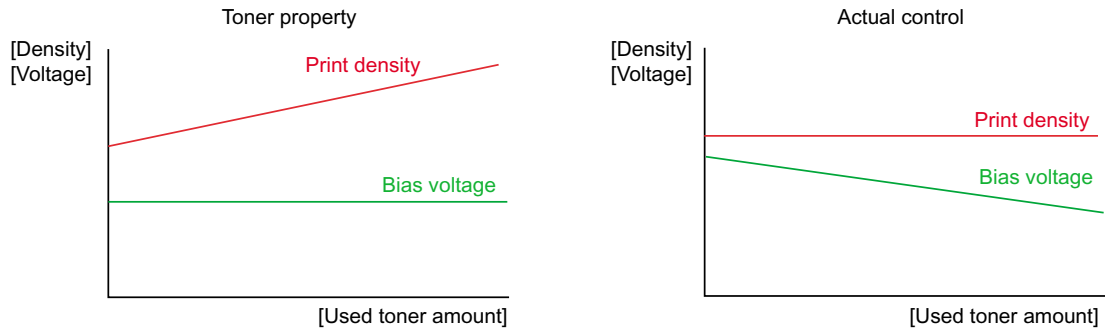

To always obtain a print result of a constant density, the printer counts the number of print pages immediately after the toner cartridge is replaced and changes the bias voltage according to the accumulated number of prints with the toner cartridge.

The bias voltage is changed with the steps described below:

- (1) When the new toner sensor detects that the toner cartridge is replaced with a new (full) one, the developing bias is set to 450V (initialized).
- (2) After that, the bias voltage is stepped down according to the number of prints.

■ **Counter reset during indication of “Toner Life End”**

The counter resetting method during indication of “Toner Life End” depends on the cause of toner life end and the condition of the inserted toner cartridge. Refer to the following table for details.

	Toner Life End (Toner empty)	Toner Life End (Developer count full)
When a used toner is inserted (Lever OFF)	Toner exchange count: +0 Page counter of each toner: Continued Coverage of each toner: Continued Development bias: Continued	Not used.
When a new toner is inserted	Toner exchange count: +1 Page counter of each toner: Reset (0) Coverage of each toner: Reset (0) Development bias: Reset (Default)	

3.2.2.7 Print process

■ Charging

The drum is charged to approximately 900V by an ion charge which is generated by the primary charger. The charge is generated by ionization of the corona wire, which has a DC bias from the high-voltage power supply applied to it. The flow of the ion charge is controlled by the grid to ensure it is distributed evenly on the drum surface. The aluminum drum sleeve in the exposure drum is grounded.

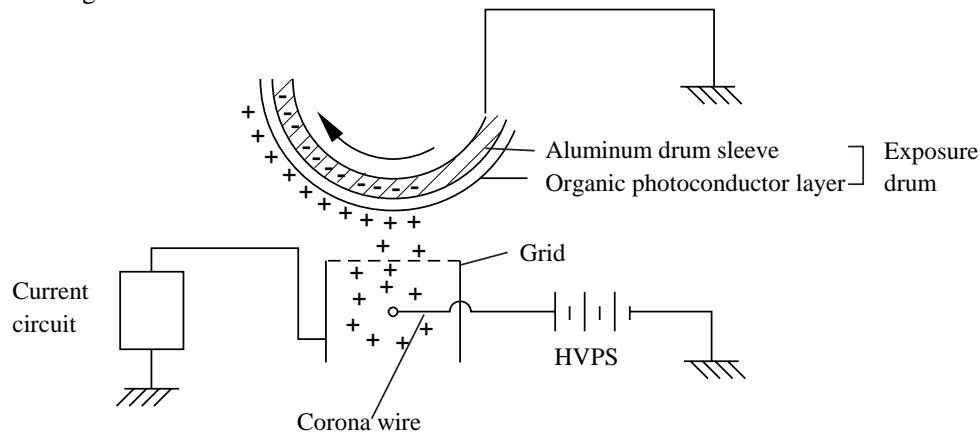

The primary charge uses a corona wire, but since the drum is positively charged, only less than 1/10 of the usual quantity of ozone is generated compared with the negatively charged drum. The level of ozone expelled from the printer is therefore not harmful to the human body. Applicable safety standards have been complied with.

■ Exposure stage

After the drum is positively charged, it is exposed to the light emitted from the laser unit.

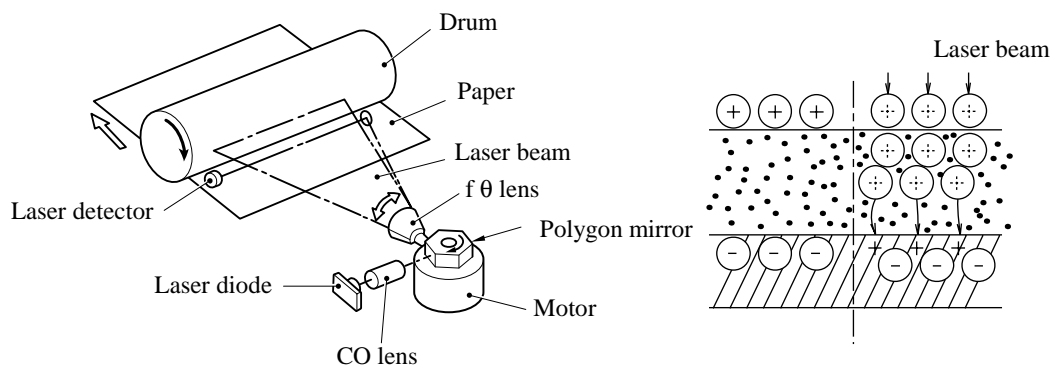

< Laser exposure unit >

1. The laser beam radiated from a laser diode inside the laser unit are concentrated into a constant width by a slit in the CO lens cell and then reflected by a polygon mirror rotating at high speed.
2. The laser beam reflected by the polygon mirror are refracted by the theta lens and radiated from the right through to the left end of the reflection mirror as the polygon mirror rotates. At this time, blur of the vertical direction of the laser beam by inclination of a polygon mirror is corrected by passing a CYL lens.

3. The laser beams reflected by the reflection mirror go straight toward the exposure drum below it, then expose the exposure drum.

The area exposed to the laser beam is the image to be printed. The surface potential of the exposed area is reduced, forming the electrostatic image to be printed.

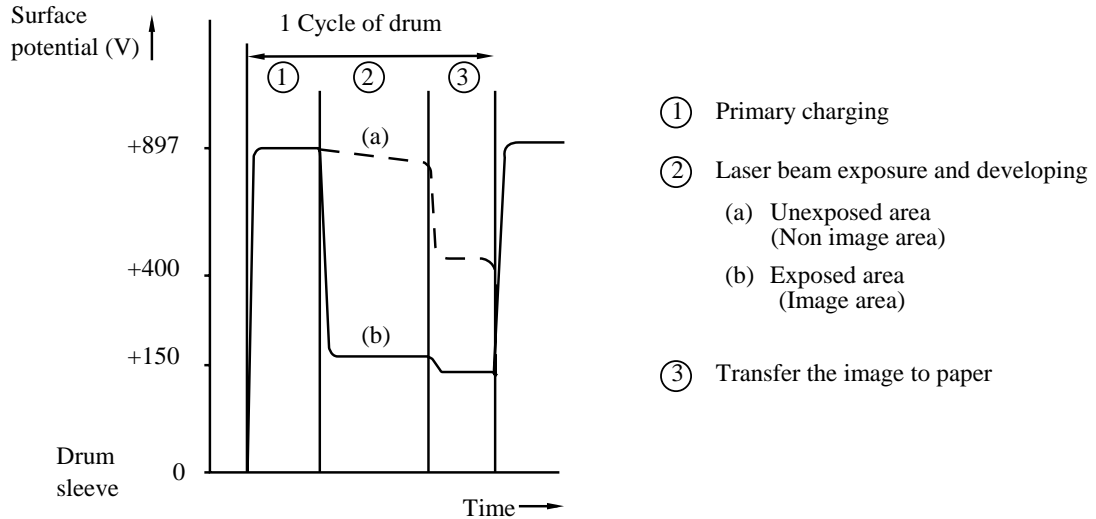

■ Developing

Developing causes the toner to be attracted to the electrostatic image on the drum so as to transform it into a visible image.

The developer consists of a non-magnetic toner. The developer roller is made of conductive rubber and the supply roller (which is also made of conductive sponge) rotate against each other. The toner is charged and carried from the supply roller to the developer roller. The toner adheres to the developer roller and is conveyed to the exposure drum at an even thickness controlled by the blade. The toner is nipped between the developer roller and the drum and developed onto the latent image on the drum. The electrostatic field between the drum and the developer roller, which is DC-biased from the high-voltage power supply, creates the electrostatic potential to attract toner particles from the developer roller to the latent image area on the drum surface.

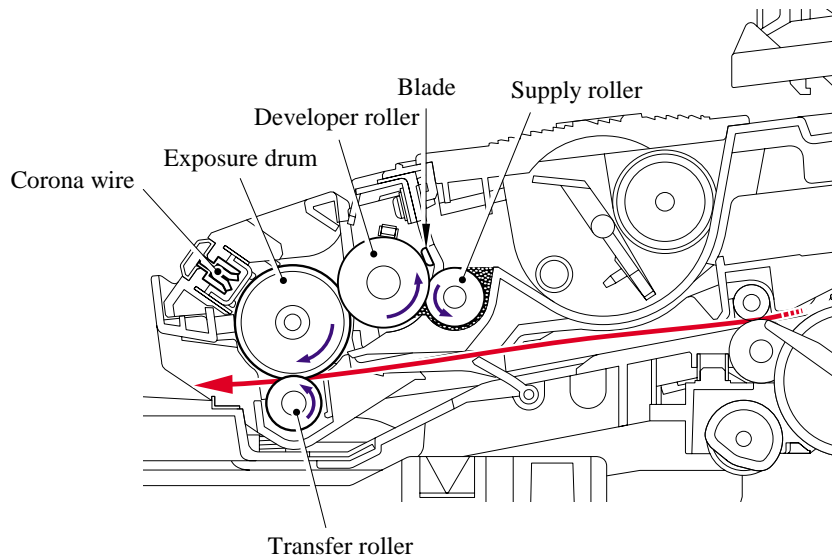

■ Transfer

(1) Transfer process

After the drum has been charged and exposed, and has received a developed image, the toner formed is transferred onto the paper by applying a negative charge to the back of the paper. The negative charge applied to the paper causes the positively charged toner to leave the drum, and adhere to the paper. As a result, the image is visible on the paper.

(2) Cleaning process of transfer roller

If the toner is not transferred onto the paper perfectly it is possible that there may be residual toner on the drum which will adhere to the transfer roller. The transfer roller voltage changes to a positive voltage during non-printing rotation of the drum. Therefore the transfer roller is cleaned by returning the positively charged toner adhering to the transfer roller onto the exposure drum.

■ Fixing stage

The image transferred to the paper by static electricity is fixed by heat and pressure when passing through the heat roller and the pressure roller in the fixing unit. The thermistor keeps the surface temperature of the heat roller constant by detecting the surface temperature of the heat roller and turning on or off the halogen heater lamp.

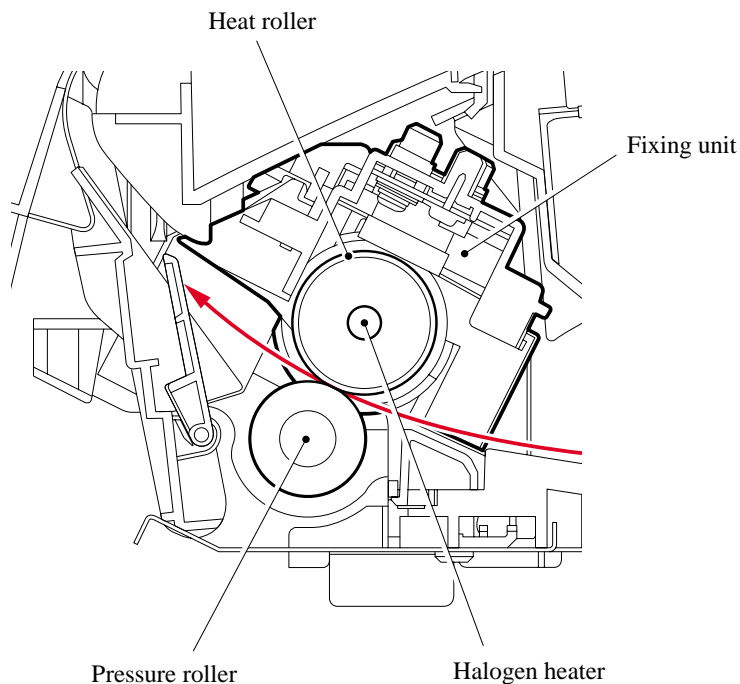

3.2.3 Sensors and Actuators

Sensor name	Sensor type	Location
Cover sensor	Mechanical switch	Main frame L
Toner LED PCB (Light emission)	Photo sensor	Main frame R
Toner sensor PCB (Light reception)	Photo sensor	Main frame L
Paper eject sensor	Photo sensor	Main PCB
Regist front sensor	Photo sensor	Regist sensor PCB
Regist rear sensor	Photo sensor	High-voltage PS PCB
Tail edge sensor	Photo sensor	Regist sensor PCB
New toner sensor	Mechanical switch	Main frame L
ADF sensor PCB ASSY	Photo sensor	ADF unit

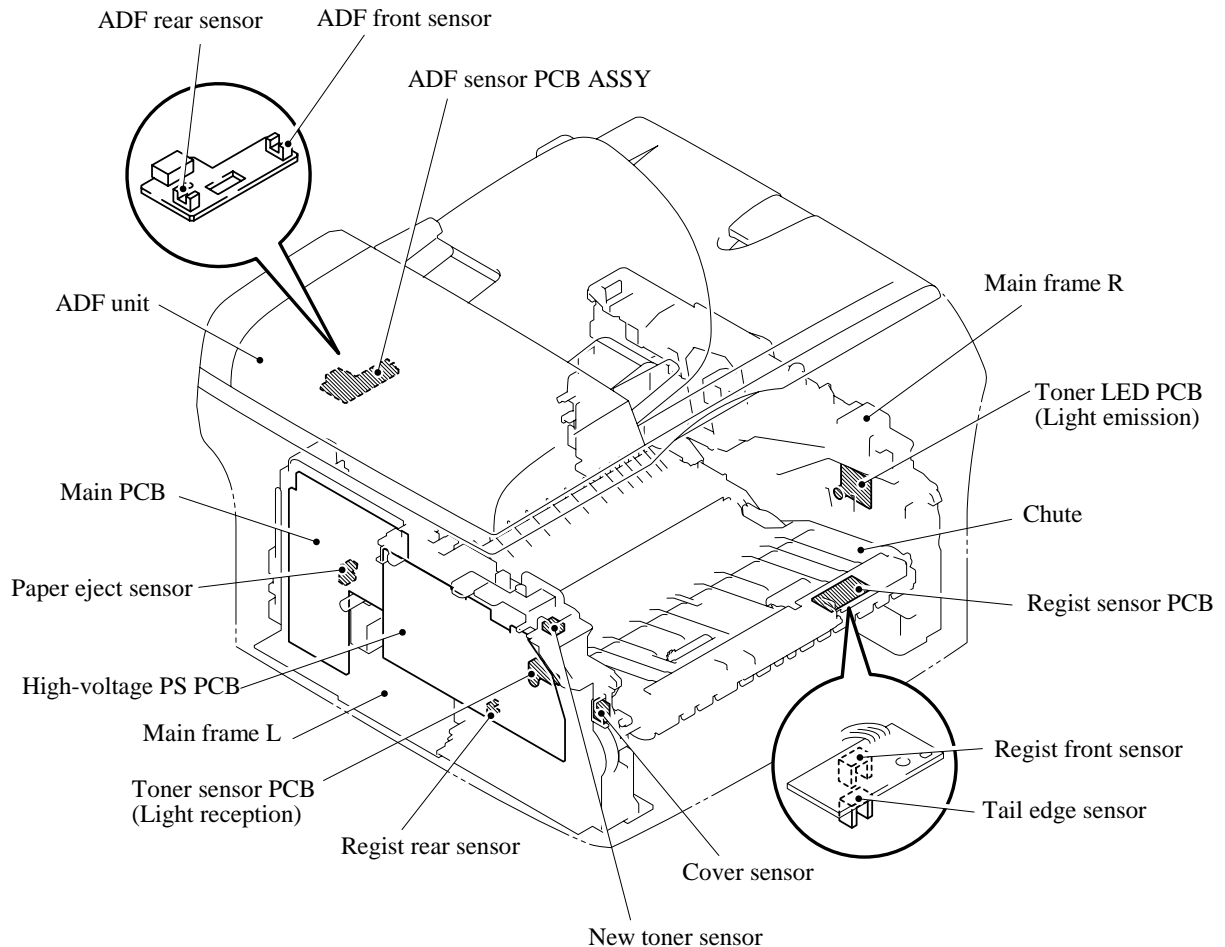

Sensors and Actuators Locations

3.3 CONTROL ELECTRONICS

3.3.1 Components

The following illustration shows the hardware components for this machine. The corresponding connection diagram appears in Appendix 5.

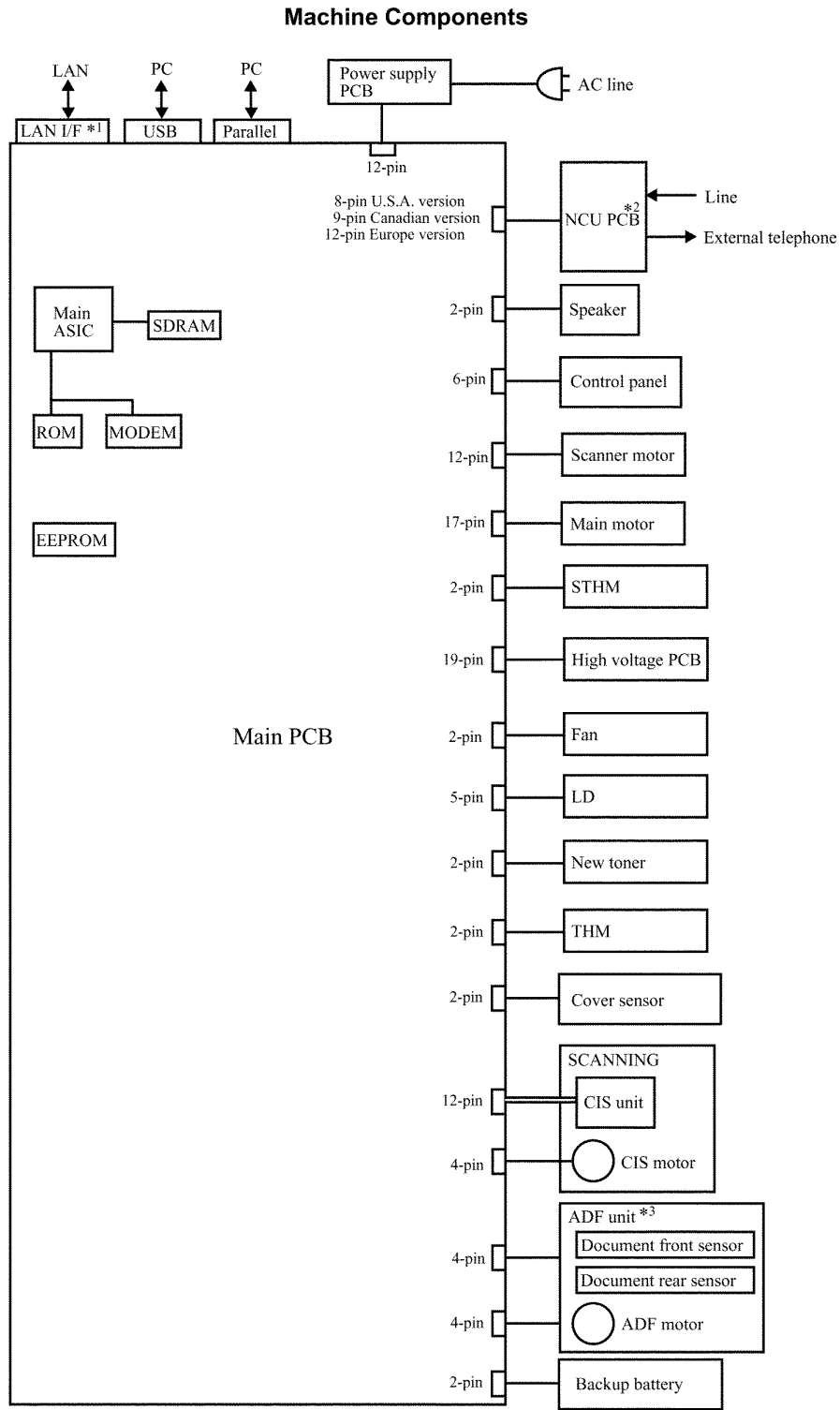

*1:MFC7820N only

*2:MFC7420/MFC7820N only

*3:DCP7020/DCP7025/MFC7420/MFC7820N

CHAPTER 4

TRANSFER OF DATA LEFT IN THE MACHINE TO BE SENT FOR REPAIR

Confidential

CHAPTER 4 TRANSFER OF DATA LEFT IN THE MACHINE TO BE SENT FOR REPAIR

This chapter describes how to transfer data left in the machine to be sent for repair. The service personnel should instruct end users to follow the transfer procedure given in this chapter if the machine at the user site cannot print received data due to the printing mechanism defective. End users can transfer received data to another machine to prevent data loss.

CONTENTS

4.1 TRANSFERRING RECEIVED FAX DATA.....	4-1
------------------------------------------------	------------

Confidential

4.1 TRANSFERRING RECEIVED FAX DATA

When the machine at the user site requires to be repaired, unplugging the power cord from the wall socket for sending the machine for repair will lose received FAX data if unprinted and left in the machine.

To prevent such data loss, the service personnel should instruct end users (e.g., by telephone) to transfer data to another facsimile machine using the procedure below.

NOTE: The number of files that can be transferred at a time is 99. To transfer 100 files or more, carry out the following procedure more than one time.

■ Operating Procedure

- (1) Connect the machine to be repaired (that has received data in the memory) to the telephone line.
- (2) Switch the machine on.
- (2) Press the **Menu/Set**, **Start**, **0**, **5** and **3** keys in this order to access user-accessible functions of the maintenance mode.
The "FAX TRANSFER" appears on the LCD.
- (4) To check the number of received files, press the **1** key.
The "1.NO. OF JOBS" appears on the LCD.
Press the **Menu/Set** key, and the number of received files appears, just as "NO. OF JOBS: 10."
- (5) To transfer the activity report only, press the **2** key.
The "2.ACTIVITY" appears.
To transfer received files together with the activity report, press the **3** key.
The "3.DOCUMENTS" appears. Note that if there is no received file, the "NO DOCUMENTS" appears.
- (6) To transfer the communication list for the latest communication, press the **4** key.
The "4.COM.LIST (NEW)" appears.
To transfer the communication list for last three errors, press the **5** key.
The "5.COM.LIST (ERR3)" appears.
- (7) With the "2.ACTIVITY," "3.DOCUMENTS," "4.COM.LIST (NEW)," or "5.COM.LIST (ERR3)" being displayed, press the **Menu/Set** key.
The "ENTER NO. &SET" appears.
- (8) Enter the telephone number of the receiver machine and press the **Menu/Set** key again.

NOTE: Be sure to type the telephone number with the numerical keys. No one-touch dialing is allowed in this procedure.

The machine displays the "ACCEPTED" for approx. two seconds and starts dialing to transfer data.

No station ID will be attached. A cover page and end page as shown on the next page will be automatically attached, instead.

Cover page sample

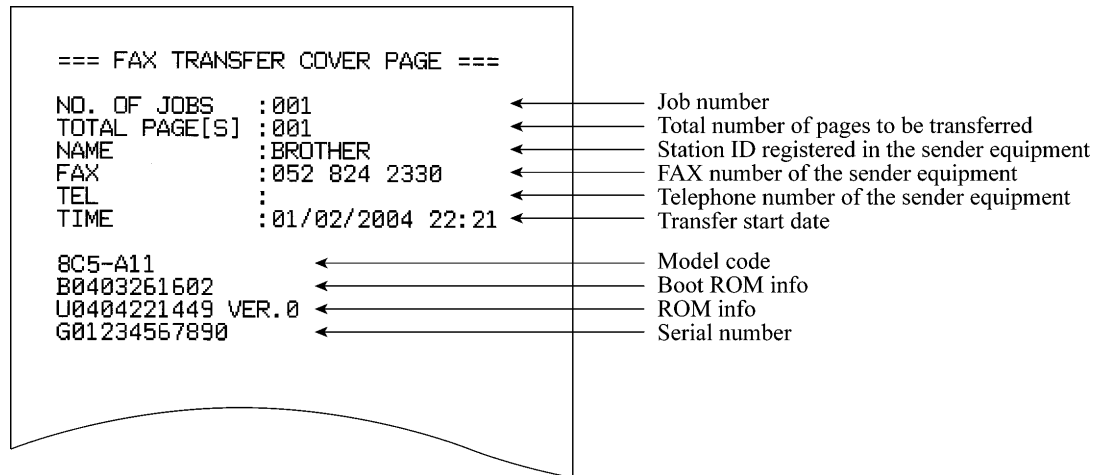

End page sample

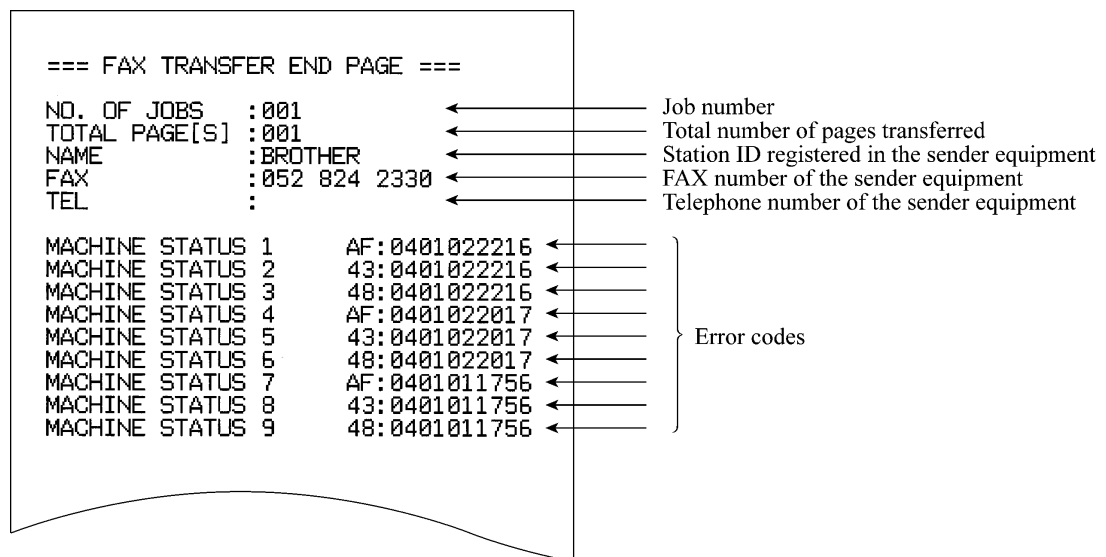

CHAPTER 5

DISASSEMBLY/REASSEMBLY AND LUBRICATION

Confidential

CHAPTER 5 DISASSEMBLY/REASSEMBLY AND LUBRICATION

This chapter details procedures for disassembling and reassembling the machine together with related notes. The disassembly order flow provided enables you to see at a glance the quickest way to get to component(s) involved.

At the start of a disassembly job, you check the disassembly order flow that guides you through a shortcut to the object components.

This chapter also covers screw tightening torques and lubrication points to which the specified lubricants should be applied during reassembly jobs.

CONTENTS

5.1 DISASSEMBLY/REASSEMBLY	5-1
■ Safety Precautions.....	5-1
■ Tightening Torque.....	5-2
■ Preparation	5-3
■ How to Access the Object Component.....	5-3
■ Disassembly Flowchart.....	5-4
5.1.1 AC Cord.....	5-5
5.1.2 Drum/Toner ASSY	5-5
5.1.3 Paper Tray.....	5-6
5.1.4 Rear Cover	5-7
5.1.5 Rear Chute Cover	5-8
5.1.6 Side Cover L.....	5-9
5.1.7 Side Cover R.....	5-10
5.1.8 ADF Unit.....	5-11
5.1.9 Pull Arm/Pull Arm Guide/Lock Claw Pull Arm Spring.....	5-25
5.1.10 Scanner Unit.....	5-26
5.1.11 Panel Unit.....	5-26
5.1.12 NCU PCB	5-30
5.1.13 Speaker	5-31
5.1.14 Joint Cover ASSY/Paper Stopper/Battery ASSY	5-33
5.1.15 Front Cover	5-36
5.1.16 Pickup Roller Holder ASSY	5-38
5.1.17 Fixing Unit	5-42

Confidential

5.1.18	High-Voltage PS PCB ASSY	5-48
5.1.19	Main PCB	5-49
5.1.20	PS PCB Unit.....	5-51
5.1.21	Laser Unit.....	5-54
5.1.22	Sub Chute ASSY.....	5-56
5.1.23	Link Lever.....	5-57
5.1.24	Tail Edge Actuator.....	5-58
5.1.25	Regist Front Actuator/Regist Front Spring	5-58
5.1.26	Regist Sensor PCB ASSY.....	5-59
5.1.27	Regist Rear Actuator/Regist Rear Spring	5-59
5.1.28	Fan Motor 60 Unit	5-60
5.1.29	Toner LED PCB ASSY/LED Holder	5-61
5.1.30	New Toner Actuator/New Toner Actuator Spring.....	5-62
5.1.31	New Toner Sensor	5-62
5.1.32	Cover Sensor	5-63
5.1.33	Toner Sensor PCB ASSY	5-63
5.1.34	Main Motor ASSY.....	5-64
5.1.35	Develop Joint.....	5-65
5.1.36	P/R Solenoid ASSY.....	5-65
5.1.37	F/R Solenoid ASSY.....	5-66
5.1.38	Main Frame L	5-68
5.1.39	Main Frame R.....	5-69
5.1.40	Harness Routing	5-70
5.2	LUBRICATION.....	5-78

Confidential

5.1 DISASSEMBLY/REASSEMBLY

■ Safety Precautions

To prevent the creation of secondary problems by mishandling, observe the following precautions during maintenance work.

- (1) Before starting disassembly/reassembly jobs, unplug the power cord and telephone line.
In particular, when having access to the power supply inside the machine, make sure that the power cord is unplugged from the electrical outlet; when having access to the main PCB or NCU PCB, make sure that both the power cord and telephone line are unplugged from the machine.
- (2) Be careful not to lose screws, washers, or other parts removed for parts replacement.
- (3) When using soldering irons and other heat-generating tools, take care not to damage the resin parts such as wires, PCBs, and covers.
- (4) Static electricity charged in your body may damage electronic parts.
Before handling the PCBs, touch a metal portion of the machine to discharge static electricity charged in your body. When transporting PCBs, be sure to wrap them in conductive sheets such as aluminum foil.
- (5) Be sure to reinsert self-tapping screws correctly, if removed.
- (6) Tighten screws to the torque values listed on the next page.
- (7) When connecting or disconnecting cable connectors, hold the connector bodies not the wires. If the connector has a lock, always slide the connector lock to unlock it.
- (8) Before reassembly, apply the specified lubricant to the specified points.
(Refer to [Section 5.2](#) in this chapter.)
- (9) After repairs, check not only the repaired portion but also that the connectors and other related portions function properly before operation checks.
- (10) After you use the machine, some internal parts are extremely HOT! To prevent injuries, be careful not to put your fingers in the areas shown in the illustration.

■ Tightening Torque

Location of screw	Screw type	Q'ty	Tightening torque N•m (kgf•cm)
Side cover L	Taptite, bind B M4x12	2	0.79 ±0.1 (8 ±1)
Side cover R	Taptite, bind B M4x12	2	0.79 ±0.1 (8 ±1)
Ground wire	Taptite, cup S M3x6	1	0.78 ±0.1 (8 ±1)
Upper document chute	Taptite, cup B M3x10	3	0.49 ±0.1 (5 ±1)
Lower document chute	Taptite, cup B M3x10	2	0.49 ±0.1 (5 ±1)
ADF FG harness	Taptite, cup S M3x6	1	0.78 ±0.1 (8 ±1)
ADF motor	Taptite, bind S M3x6	1	0.69 ±0.1 (8 ±1)
Document cover ASSY	Taptite, bind S M3x6	1	0.78 ±0.1 (8 ±1)
Hinge ASSY L	Taptite, bind B M4x12	3	0.49 ±0.1 (5 ±1)
Hinge arm	Taptite, bind B M4x12	1	0.78 ±0.1 (8 ±1)
Panel unit	Taptite, cup B M3x10	4	0.49 ±0.1 (5 ±1)
NCU unit	Taptite, bind B M4x12	2	0.78 ±0.1 (8 ±1)
NCU FG harness	Screw, pan (s/p washer) M3.5x6	1	0.49 ±0.1 (5 ±1)
NCU shield plate	Screw, pan (s/p washer) M3.5x6	1	0.49 ±0.1 (5 ±1)
NCU PCB ASSY	Taptite, cup S M3x6	2	0.29 ±0.1 (3 ±2)
Rear cover stopper	Taptite, bind B M4x12	1	0.29 ±0.1 (3 ±1)
Inner chute	Taptite, bind B M4x12	2	0.29 ±0.1 (3 ±1)
Joint cover	Taptite, bind B M4x12	2	0.49 ±0.1 (5 ±1)
Fixing unit	Taptite, bind B M4x12	2	0.78 ±0.1 (8 ±1)
Halogen heater	Screw, pan (s/p washer) M3x8	2	0.59 ±0.05 (6 ±0.5)
Thermistor ASSY	Taptite, cup B M3x12	1	0.59 ±0.1 (6 ±1)
High voltage PS PCB	Taptite, bind B M4x12	2	0.78 ±0.1 (8 ±1)
Main PCB	Taptite, cup S M3x6	2	0.69 ±0.1 (7 ±1)
	Taptite, cup S M3x6	4	0.69 ±0.1 (7 ±1)
	Taptite, flat S M3x8	2	0.69 ±0.1 (7 ±1)
LV shield plate cover	Taptite, cup S M3x6	2	0.59 ±0.1 (6 ±1)
	Screw, pan (s/p washer) M3.5x6	3	0.49 ±0.1 (5 ±1)
LV shield plate	Taptite, bind B M4x12	1	0.78 ±0.1 (8 ±1)
	Screw, pan (s/p washer) M3.5x6	1	0.49 ±0.1 (5 ±1)
	Taptite, flat S M3x8	2	0.59 ±0.1 (6 ±1)
PS PCB	Taptite, cup S M3x6	2	0.69 ±0.1 (7 ±1)
Laser unit	Taptite, cup S M3x6	4	0.69 ±0.1 (7 ±1)
Air duct	Taptite, cup S M3x6	1	0.69 ±0.1 (7 ±1)
Sub chute ASSY	Taptite, bind B M4x12	2	0.78 ±0.1 (8 ±1)
Laser unit	Taptite, cup S M3x6	4	0.69 ±0.1 (7 ±1)
Air duct	Taptite, cup S M3x6	1	0.69 ±0.1 (7 ±1)
Sub chute ASSY	Taptite, bind B M4x12	2	0.78 ±0.1 (8 ±1)
Regist sensor PCB ASSY	Taptite, bind B M3x6	1	0.39 ±0.1 (4 ±1)
Base plate	Taptite, bind B M4x12	3	0.78 ±0.1 (8 ±1)
Toner sensor PCB	Taptite, cup B M3x6	1	0.39 ±0.1 (4 ±1)
Gear plate calking ASSY	Taptite, bind B M4x12	5	0.78 ±0.1 (8 ±1)
Main motor	Taptite, cup S M3x6	3	0.69 ±0.1 (7 ±1)
P/R solenoid ASSY	Taptite, bind B M3x10	1	0.49 ±0.1 (5 ±1)
F/R solenoid ASSY	Taptite, bind B M3x10	1	0.49 ±0.1 (5 ±1)
Main frame L	Taptite, bind B M4x12	2	0.78 ±0.1 (8 ±1)
Main frame R	Taptite, bind B M4x12	3	0.78 ±0.1 (8 ±1)

■ **Preparation**

Prior to proceeding with the disassembly procedure,

(1) Unplug

- the modular jack of the telephone line,
- the USB cable, if connected (not shown below), and
- the modular jack of the external telephone set if connected (not shown below).

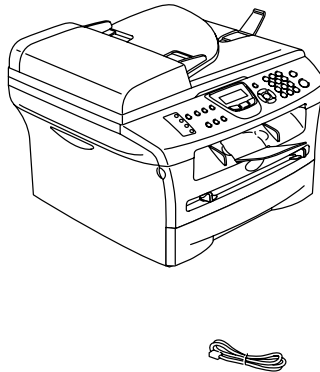

■ **How to Access the Object Component**

- On the next page is a disassembly flowchart which helps you access the object components. To remove the fixing unit, for example, first find it on the flowchart and note its number (5.1.17 in this case). To access it, you need to remove all the parts above the fixing unit on the flowchart (5.1.4, 5.1.5, 5.1.7 and 5.1.14 in this case) before the unit itself can be removed.
- Unless otherwise specified, all parts should be replaced in the reverse order to which they were removed to reassemble the machine.

■ Disassembly Flowchart

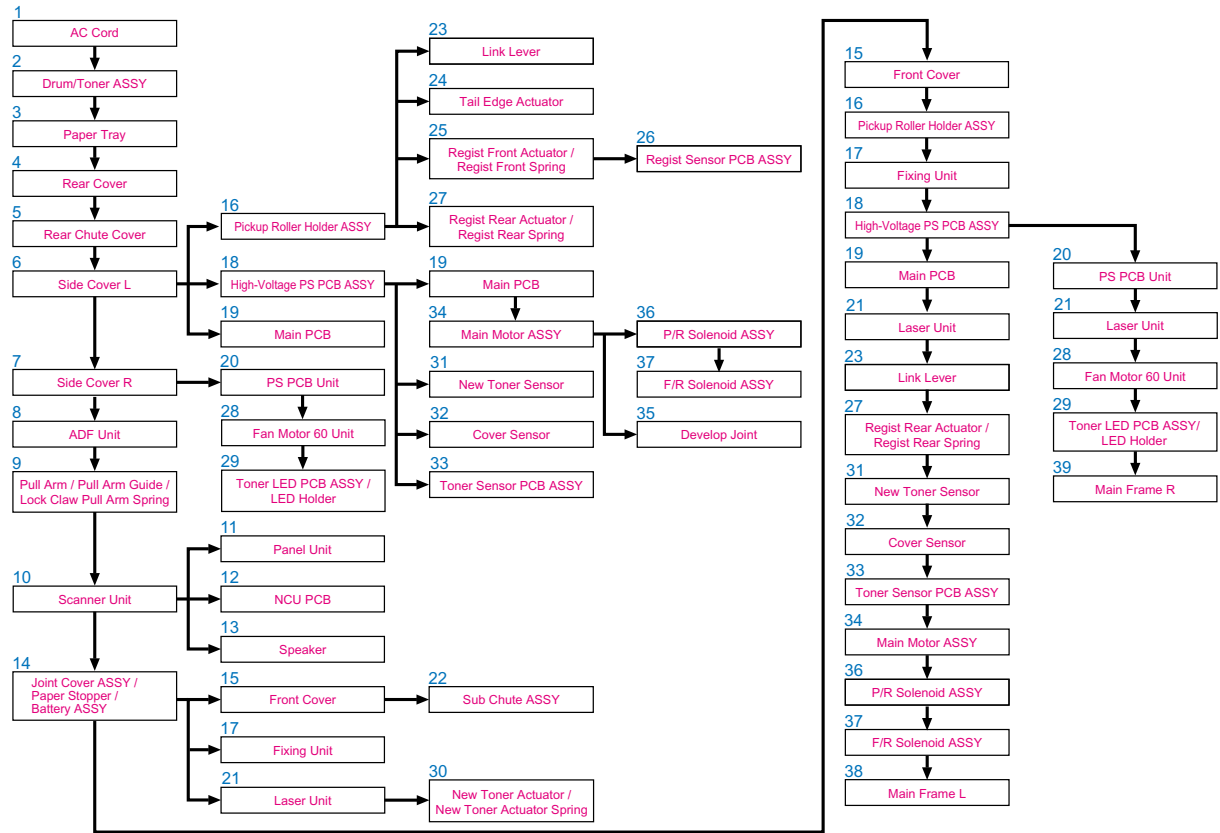

5.1.1 AC Cord

- (1) Disconnect AC cord from the machine.

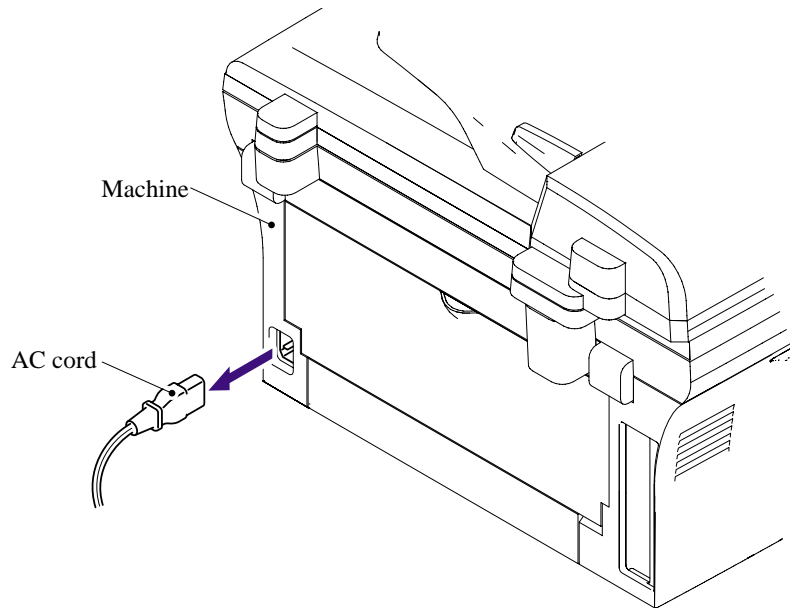

5.1.2 Drum/Toner ASSY

- (1) Open the front cover and remove the drum/toner ASSY.

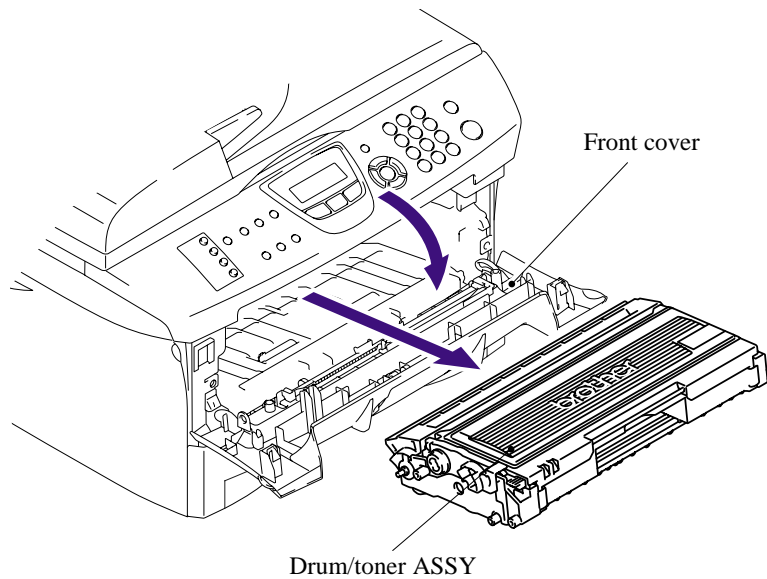

5.1.3 Paper Tray

- (1) Close the front cover and pull out the paper tray.
- (2) Remove the paper from the paper tray.

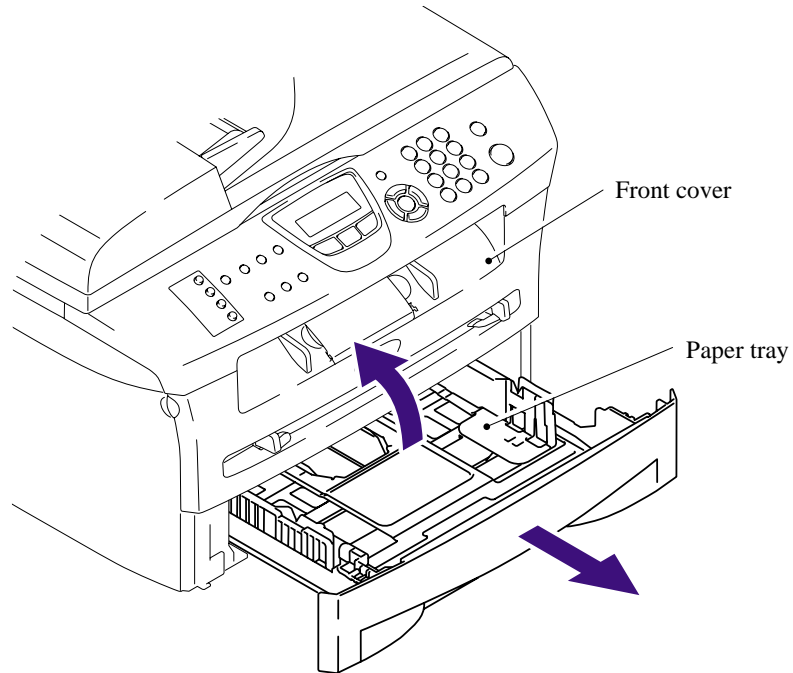

- (3) Remove the separation pad holder ASSY and the separation pad spring.

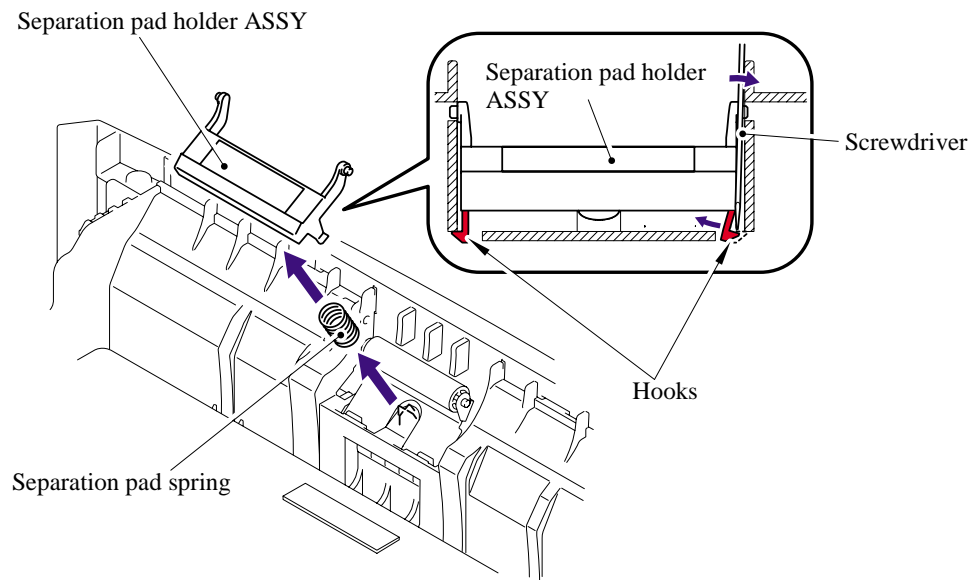

5.1.4 Rear Cover

- (1) Remove the rear cover.

NOTE: Remove the "A" section of the rear cover while opening the rear cover slightly.

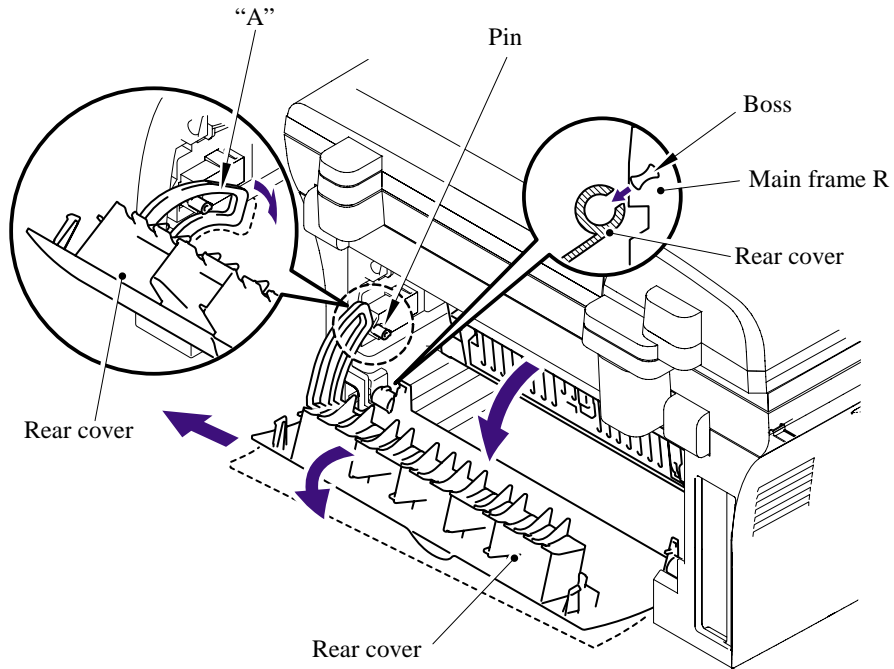

5.1.5 Rear Chute Cover

(1) Remove the rear chute cover.

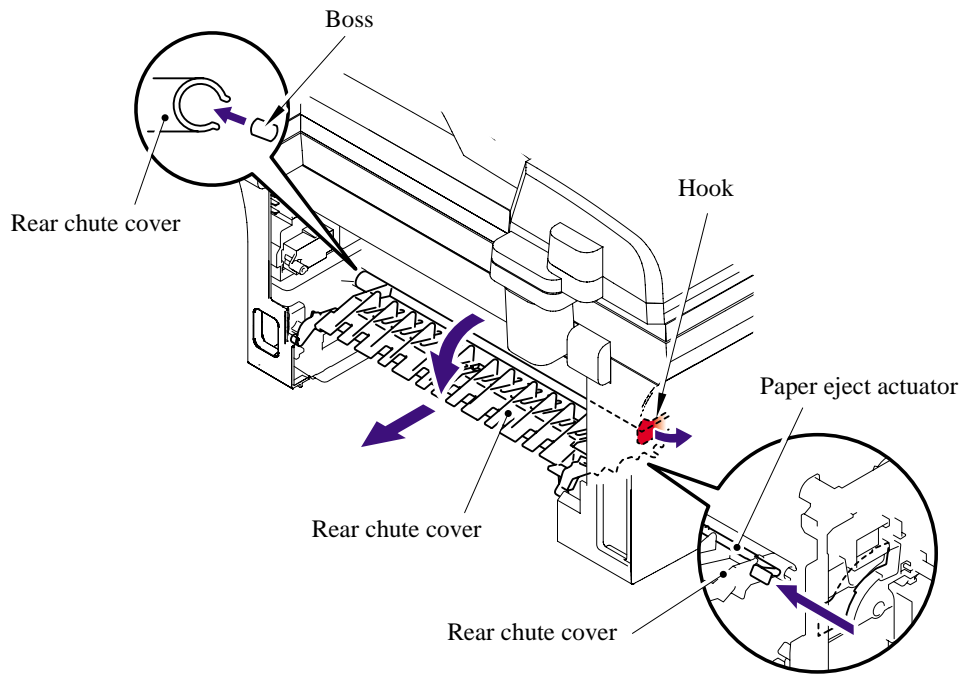

(2) Remove the paper eject actuator and the eject actuator spring.

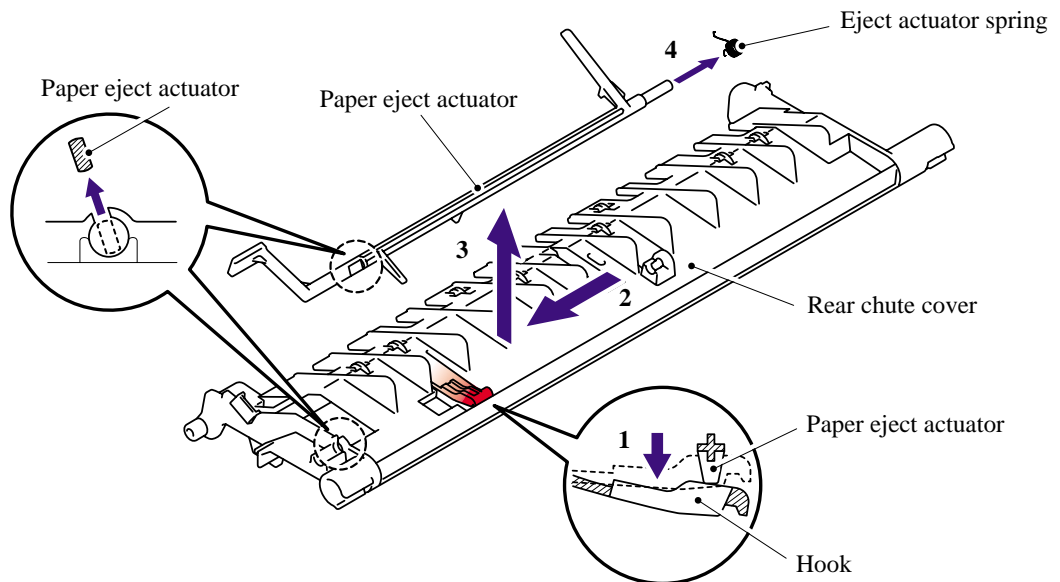

5.1.6 Side Cover L

- (1) Open the front cover.
- (2) Remove the two bind B M4x12 taptite screws, and then remove the side cover L.

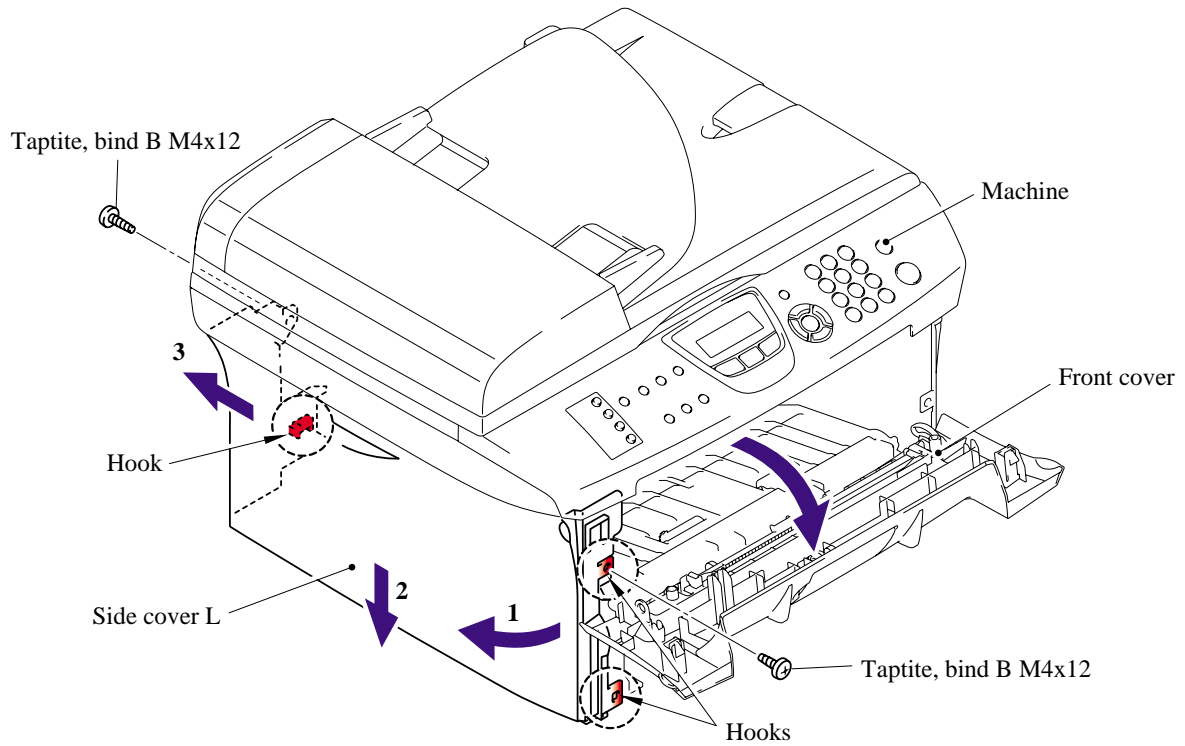

5.1.7 Side Cover R

(1) Remove the two bind B M4x12 taptite screws, and then remove the side cover R.

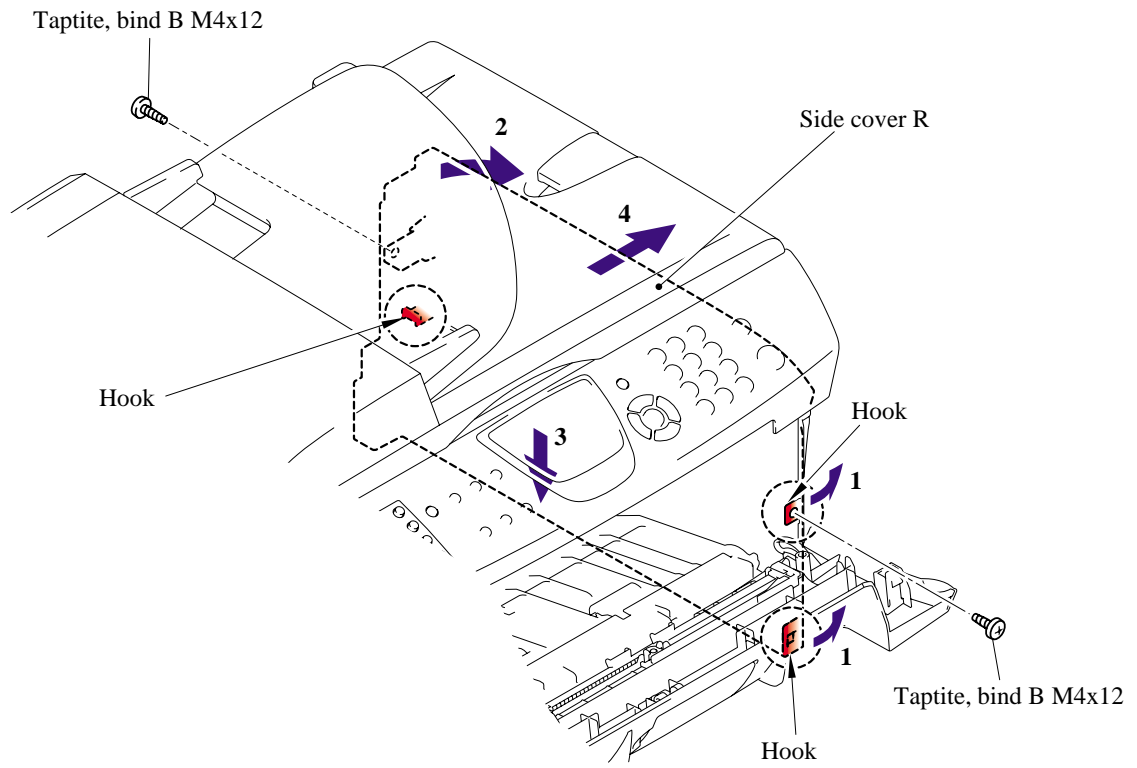

5.1.8 ADF unit

- (1) Open the ADF unit and scanner unit.
- (2) Remove the one cup S M3x6 taptite screw and ADF FG harness and FB FG harness.
- (3) Disconnect the two connectors of the ADF unit from the main PCB.
- (4) Disconnect the two connectors of the scanner unit from the main PCB.

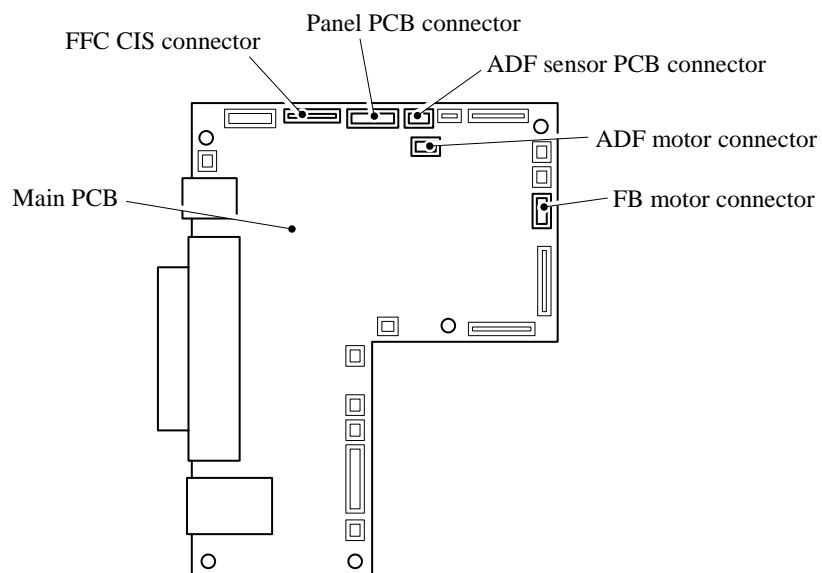
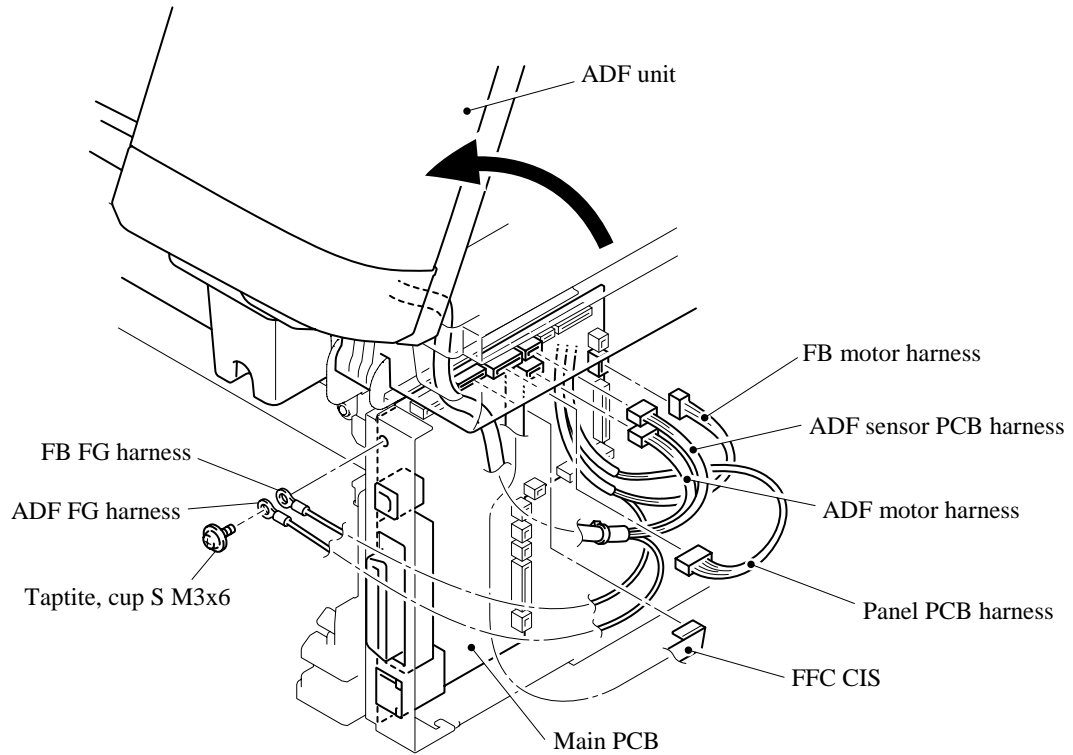

- (5) Close the ADF cover and scanner unit.
- (6) Remove the two pins and remove the ADF cover.

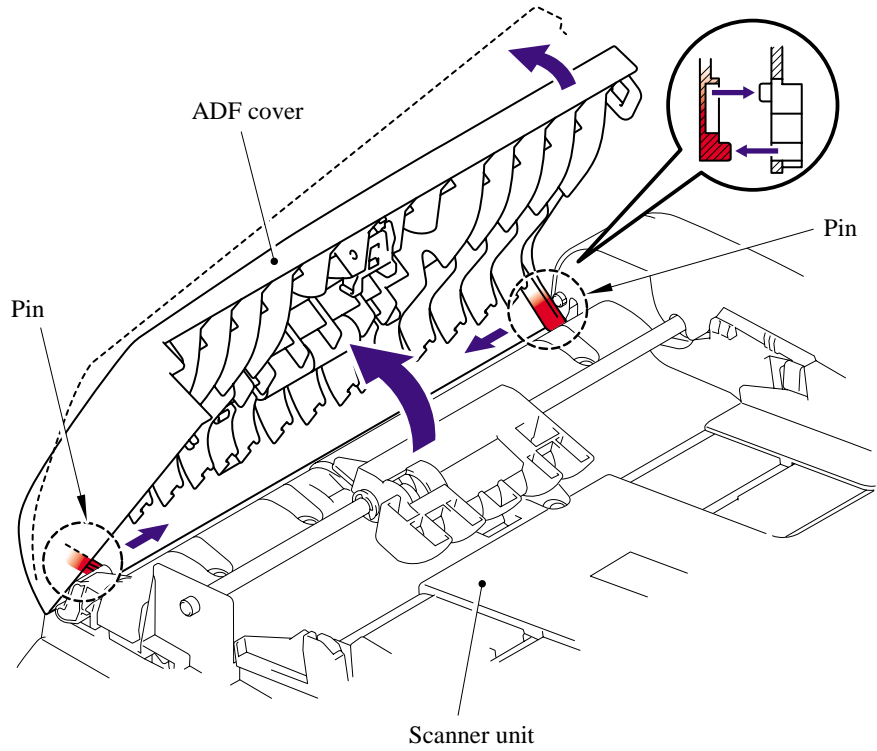

- (7) Release the two hooks from the ADF cover and remove the pressure roller ASSY.
- (8) Remove the two LF springs from the ADF cover.

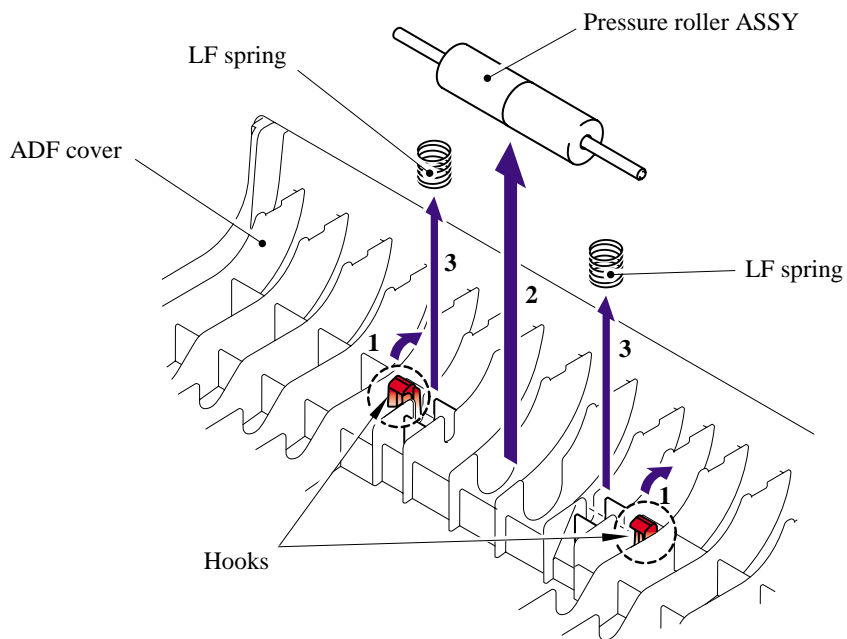

- (9) Remove the two pressure rollers from the pressure roller shaft.

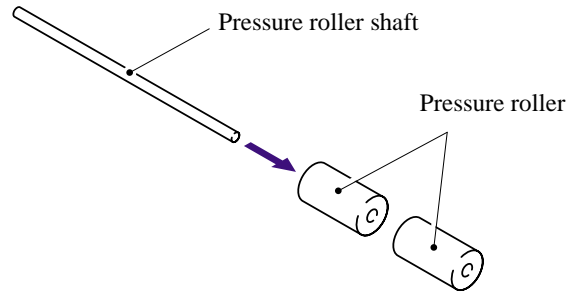

- (10) Open the ADF unit.

- (11) Release the hook to remove the gear cover from the ADF unit.

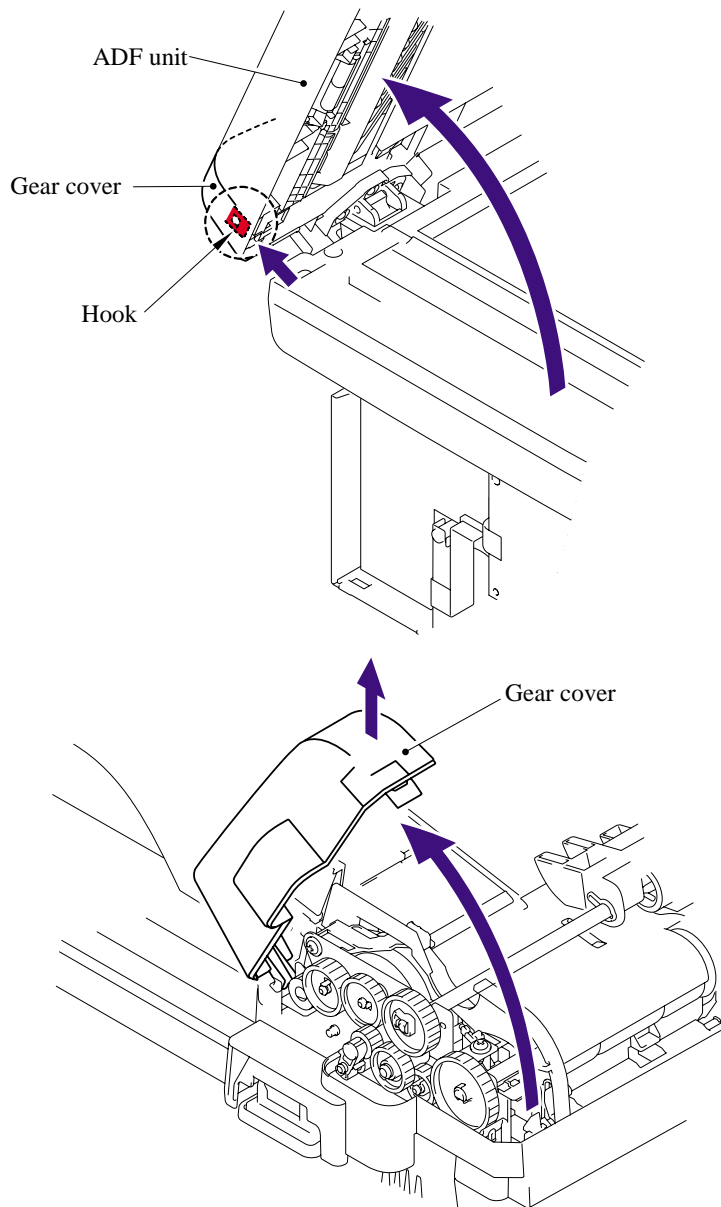

(12) Close the ADF unit.

(13) Remove the separate roller shaft ASSY and bushing from the ADF unit.

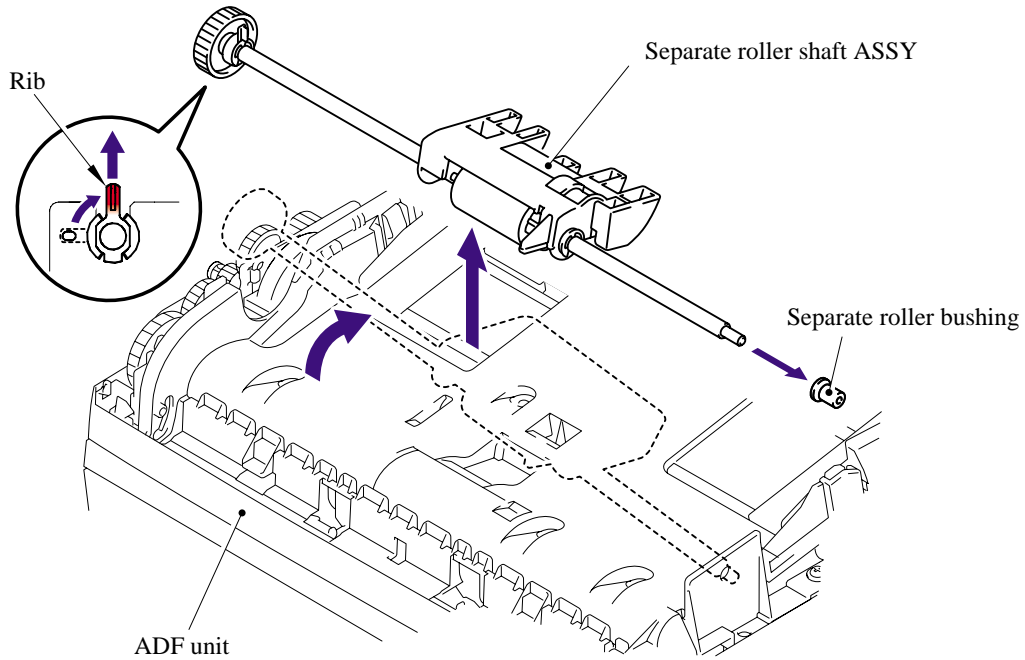

(14) Remove the four cup B M3x10 taptite screws.

(15) Release the three hooks "A" to remove the upper document chute.

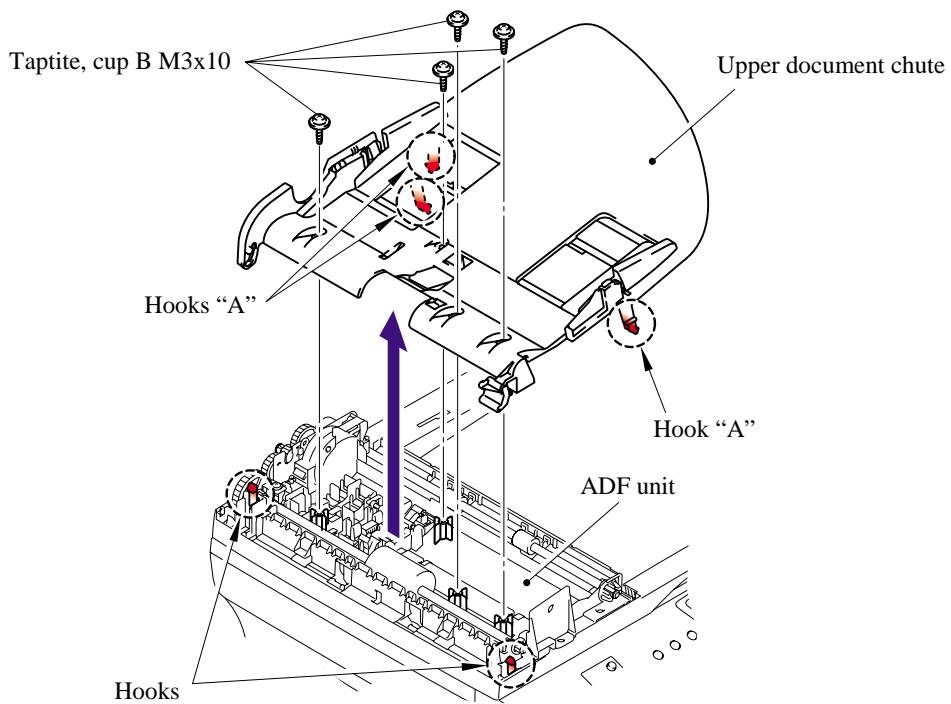

(16) Remove the separation rubber ASSY from the upper document chute.

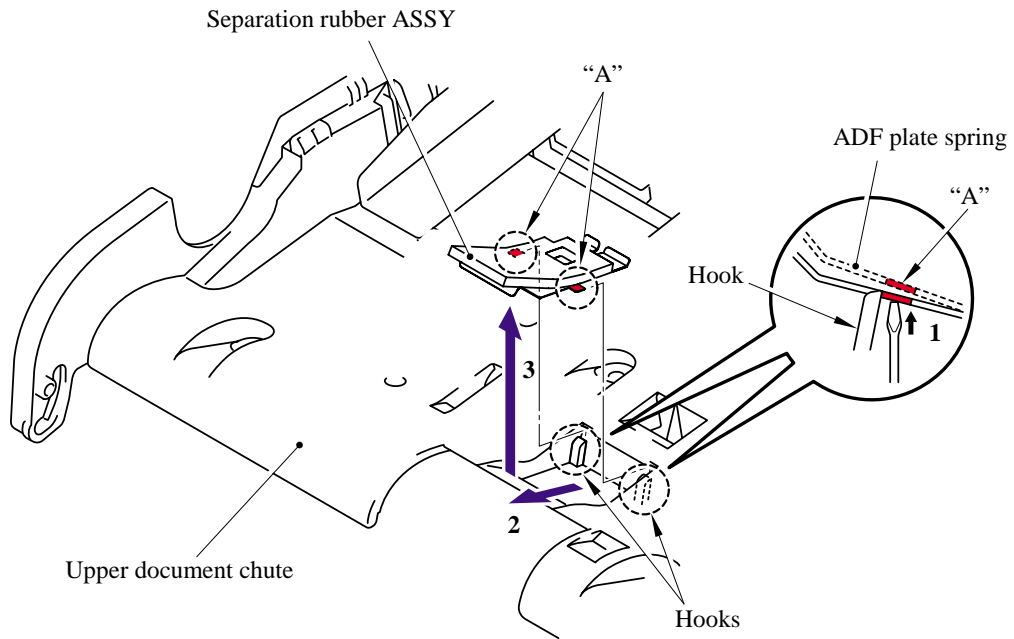

(17) Remove the separation rubber from the ADF plate spring.

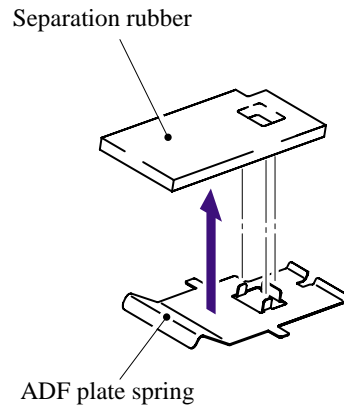

- (18) Remove the two cup B M3x10 taptite screws from the lower document chute.
- (19) Release the two hooks to remove the lower document chute.

NOTE: When re-connecting the connectors, put them through the holes on the ADF unit before connecting.

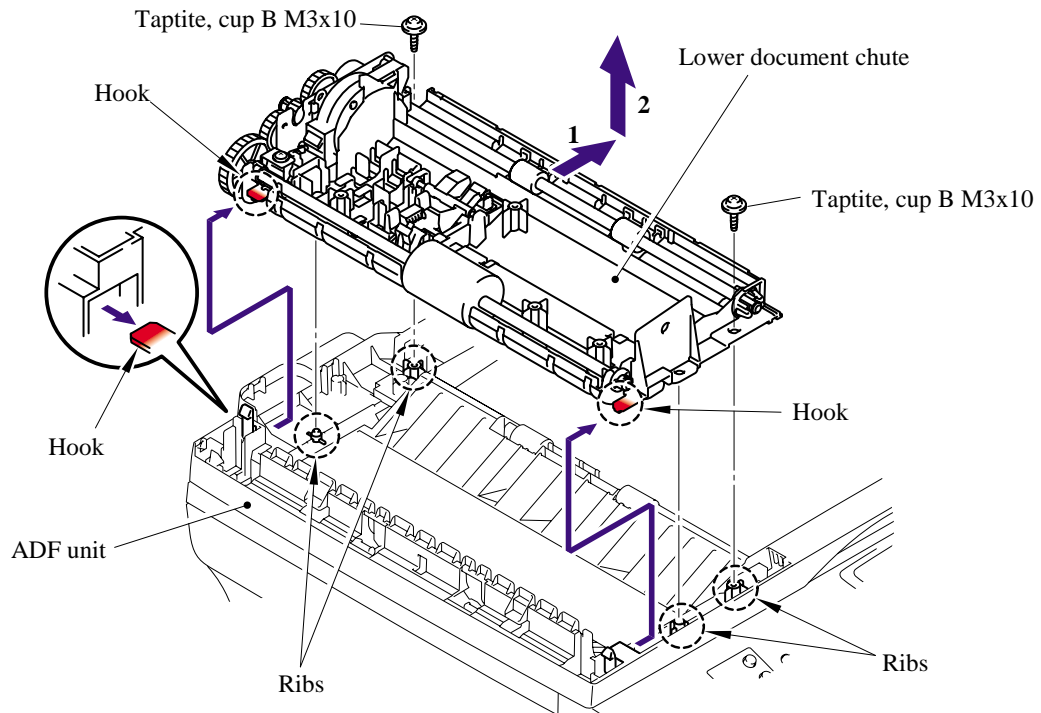

- (20) Release the hook on the ADF unit and remove the ejection roller ASSY.

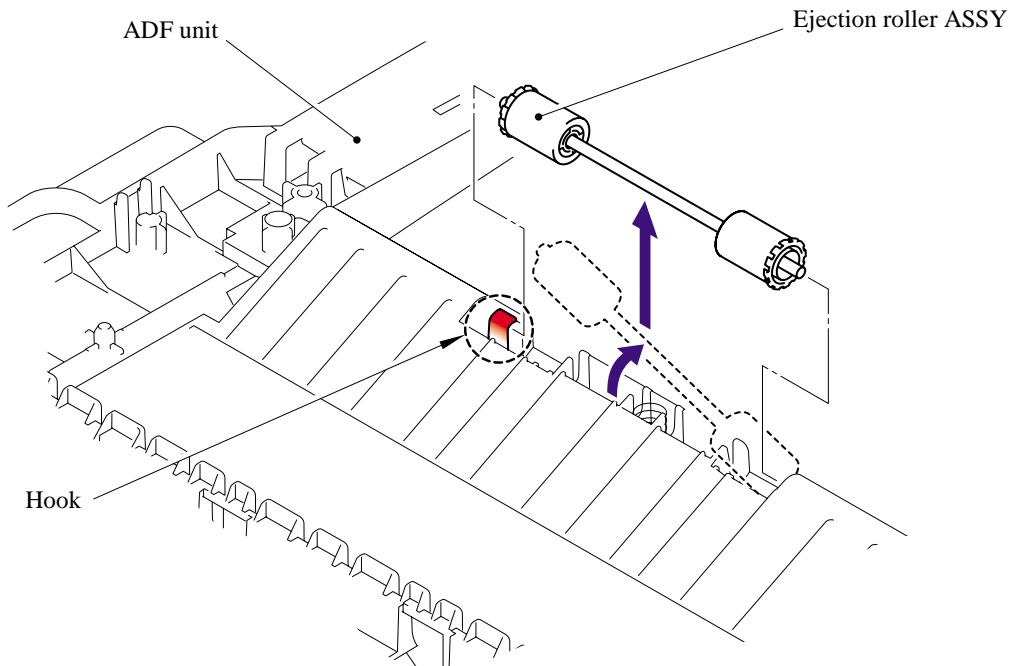

(21) Remove the two ejection rollers from the pressure roller shaft.

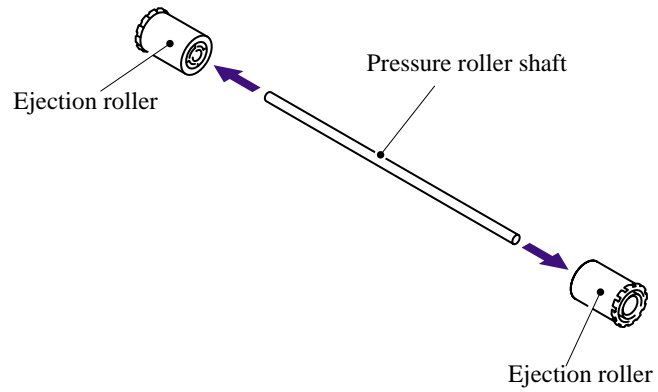

(22) Remove the ADF unit ejection spring from the ADF unit.

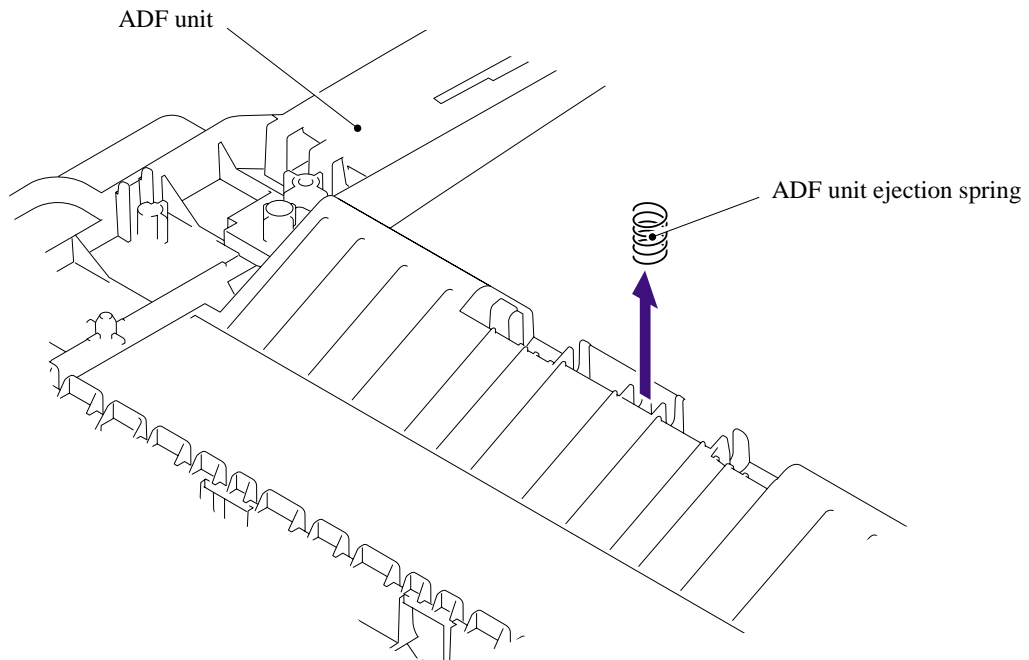

- (23) Release the two hooks and remove the resin bearing.
- (24) Remove the LF roller ASSY from the lower document chute.

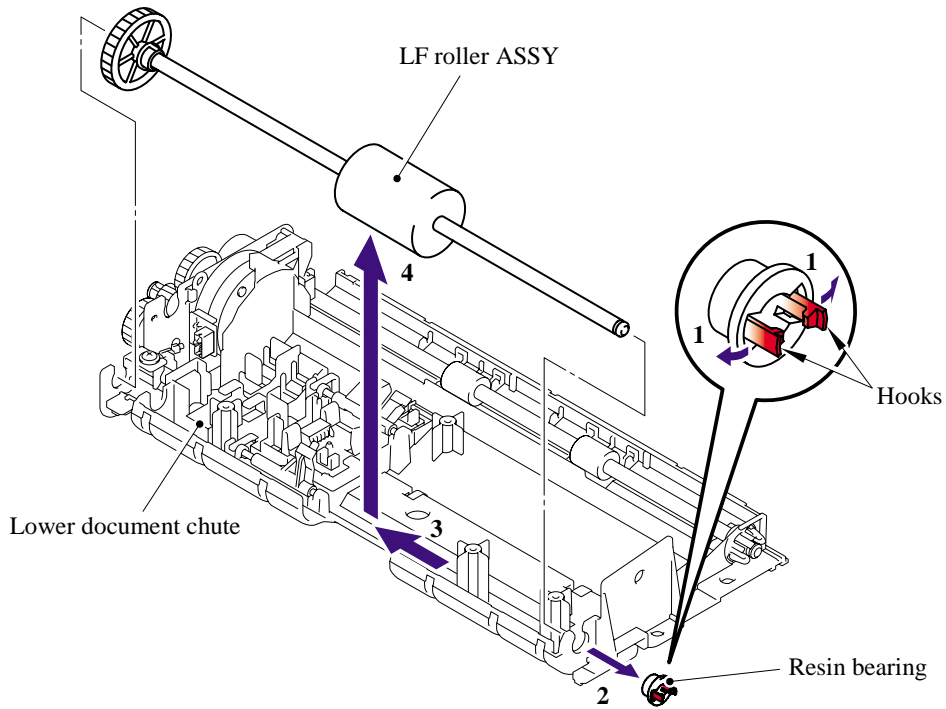

- (25) Release the two hooks "A" and remove the the ejection roller ASSY from the lower document chute.
- (26) Release the two hooks "B" and remove the ejection roller bearing from the ejection roller ASSY.

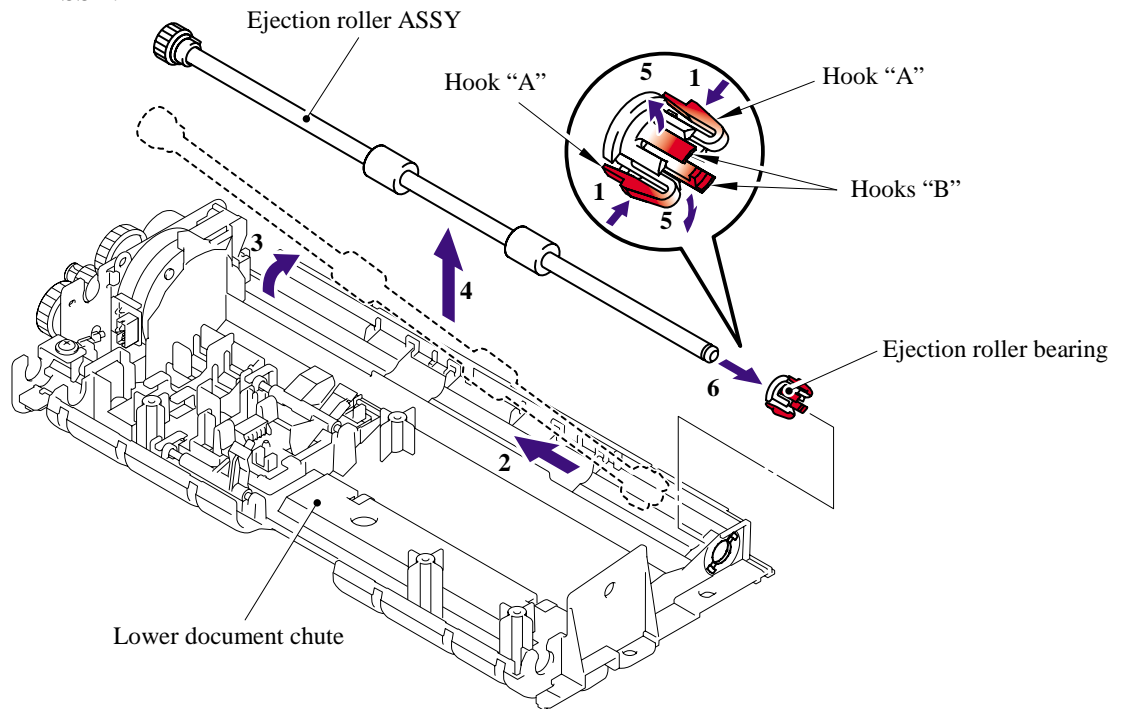

- (27) Remove the two cup B M3x10 taptite screws and one cup S M3x6 taptite screw from the lower document chute.
- (28) Remove the drive frame ASSY from the lower document chute.

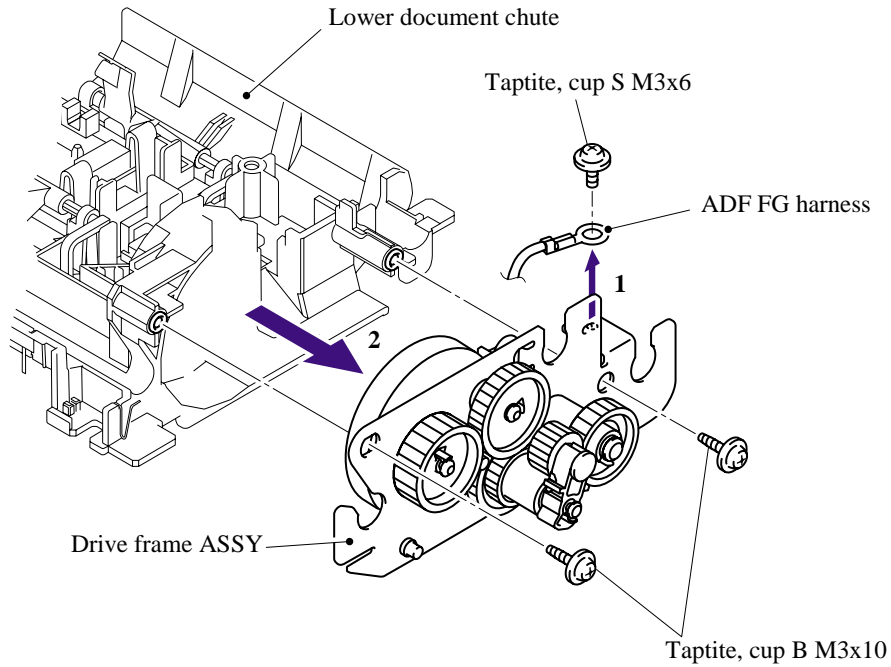

- (29) Remove the one bind S M3x6 taptite screw from the drive frame ASSY to remove the ADF motor.
- (30) Remove the ADF motor harness from the ADF motor.

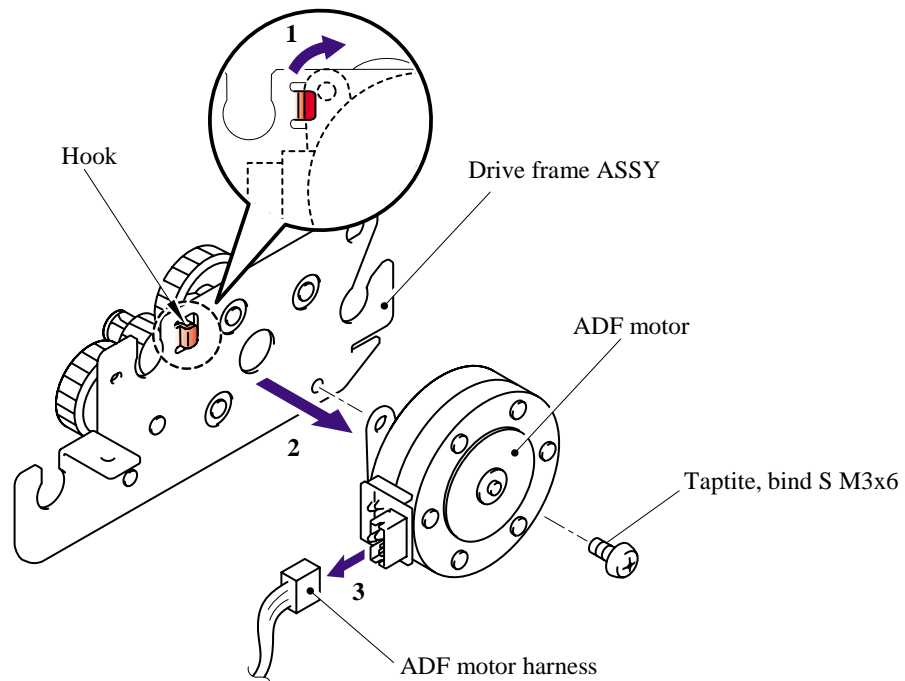

NOTE: When re-assembling drive frame ASSY, assemble it so that the arm ASSY is at the top.

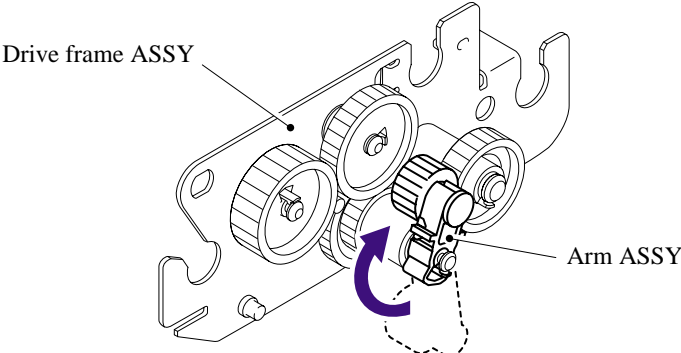

(31) Remove the document rear actuator from the lower document chute.

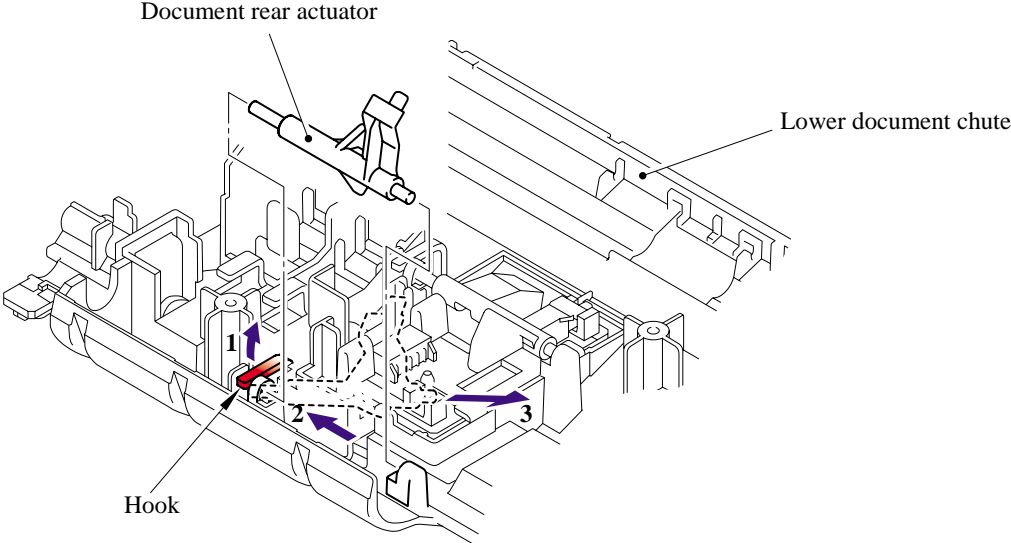

(32) Remove the document front actuator from the lower document chute.

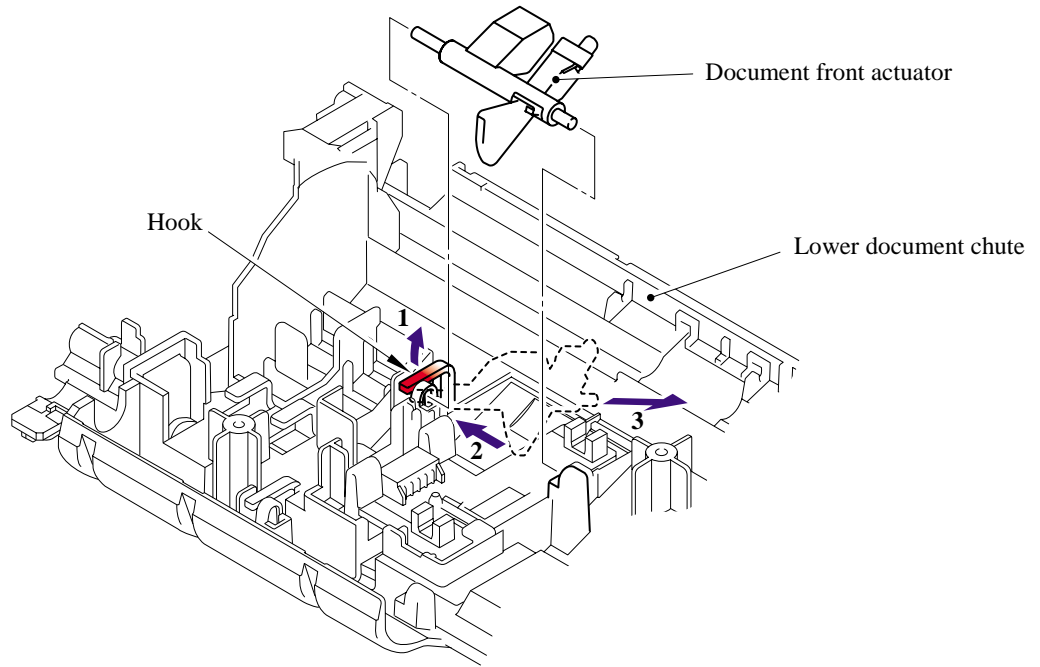

(33) Release the two hooks "A" on the lower document chute to remove the ADF sensor PCB ASSY.

(34) Remove the ADF sensor harness ASSY.

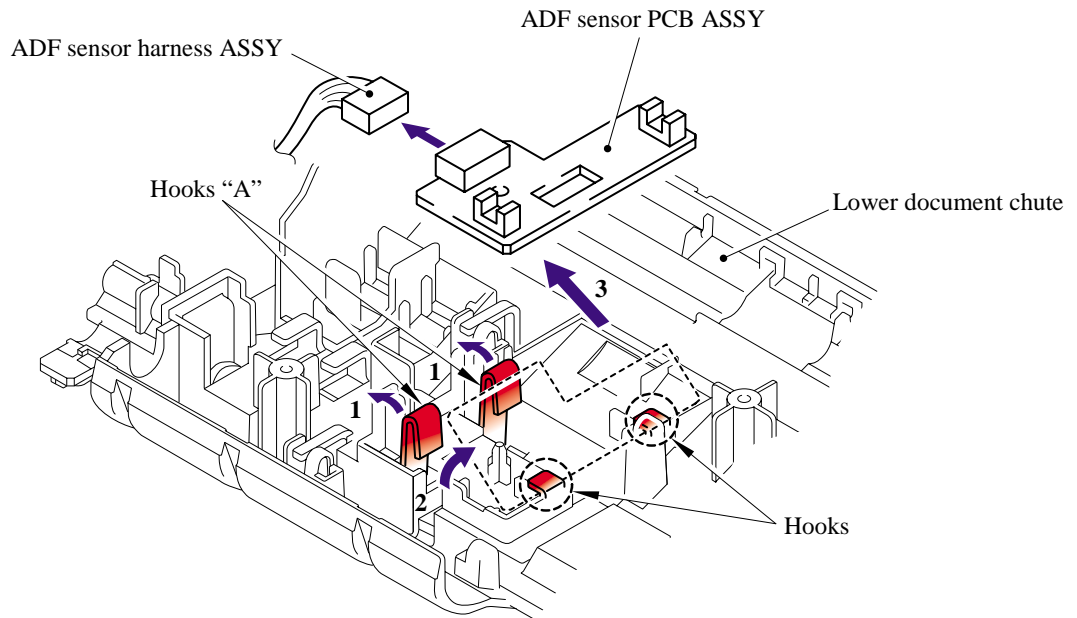

- (35) Turn the lower document chute upside down.
- (36) Remove the pins and remove the document hold.
- (37) Remove the document spring from the lower document chute.

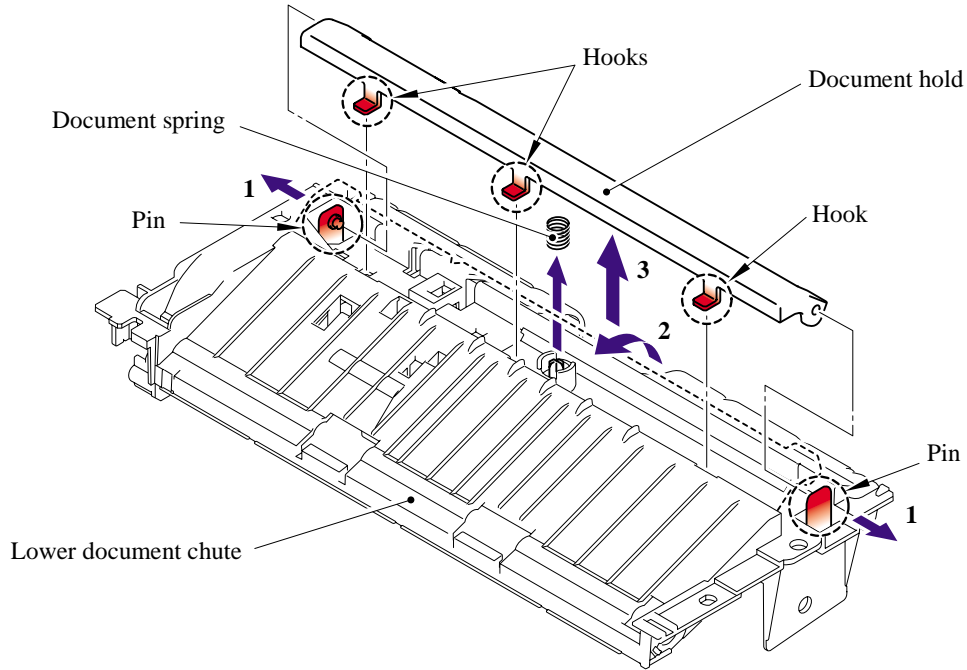

- (38) Open the ADF unit.
- (39) Remove the one bind B M4x12 taptite screw from the document cover sub ASSY.
- (40) Release the hook to remove the document cover ASSY.

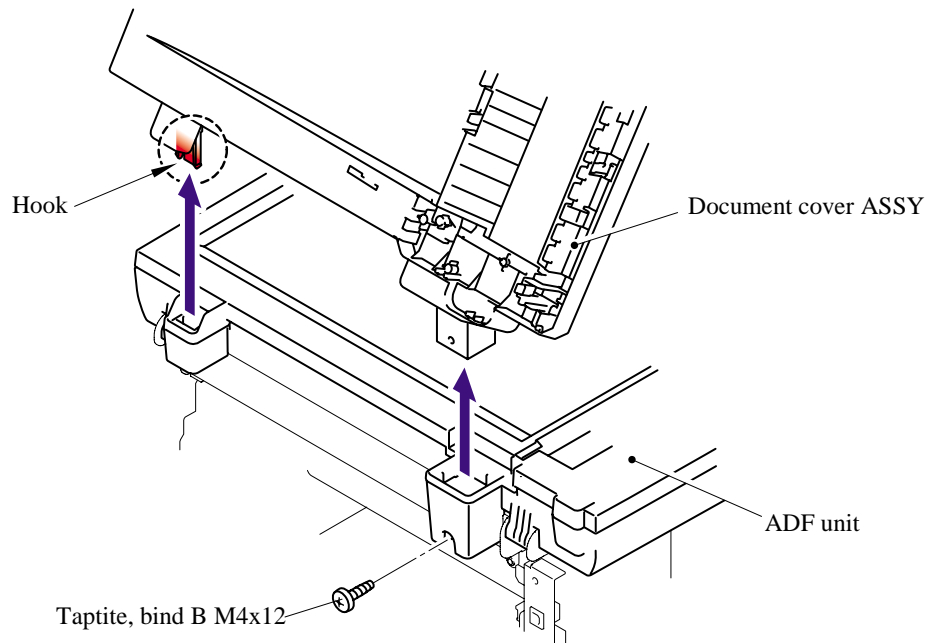

- (41) Remove the two springs.
- (42) Remove the pressure roller ASSY.

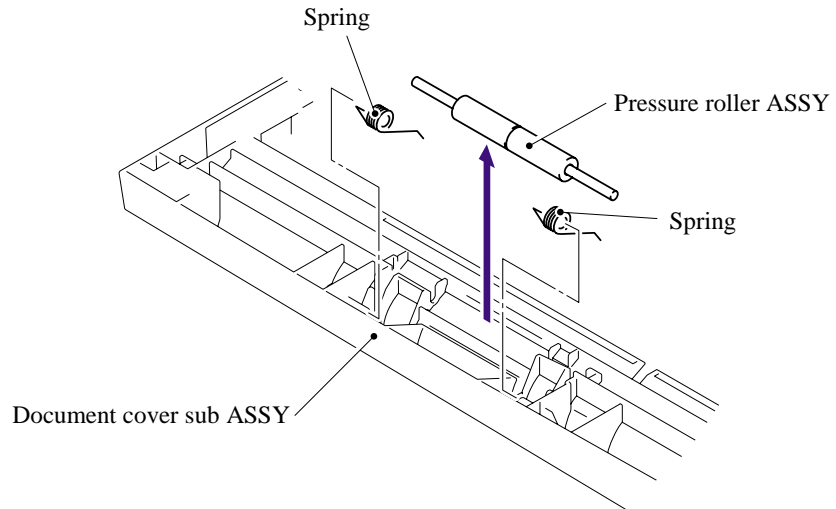

- (43) Remove the two pressure rollers from the pressure roller shaft.

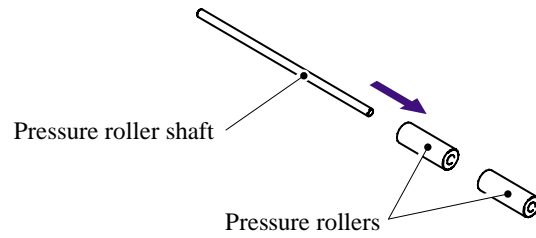

- (44) Remove the three cup B M3x10 taptite screws to remove the hinge ASSY L.
- (45) Remove the hinge from the hinge arm.
- (46) Remove the one bind B M4x12 taptite screw to remove the hinge arm.

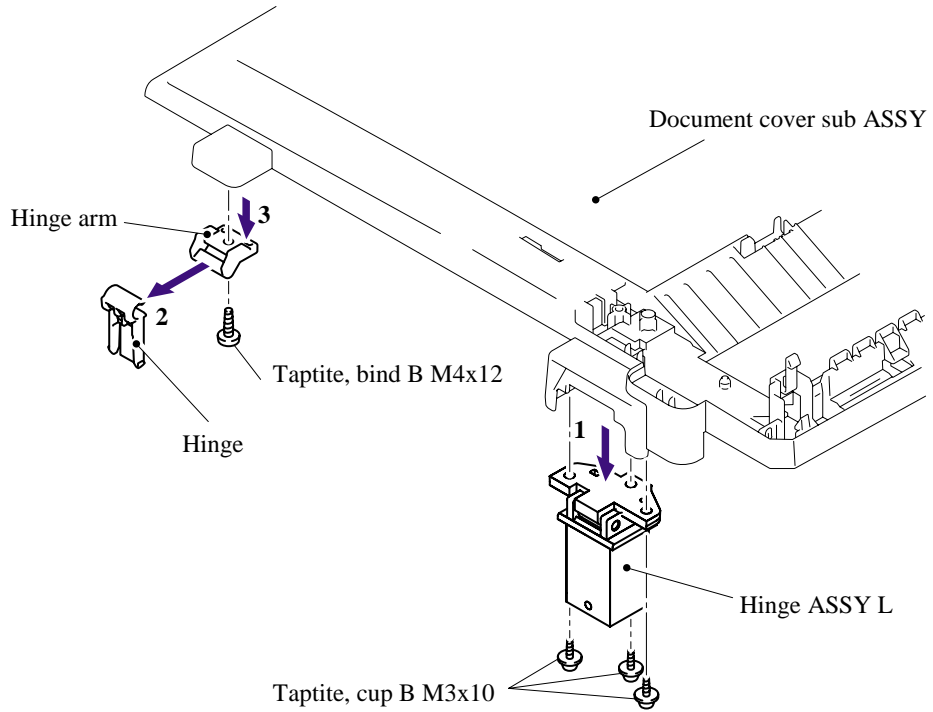

5.1.9 Pull Arm/Pull Arm Guide/Lock Claw Pull Arm Spring

- (1) Open the scanner unit.
- (2) Release the hook to remove the scanner unit side of the pull arms (R, L).

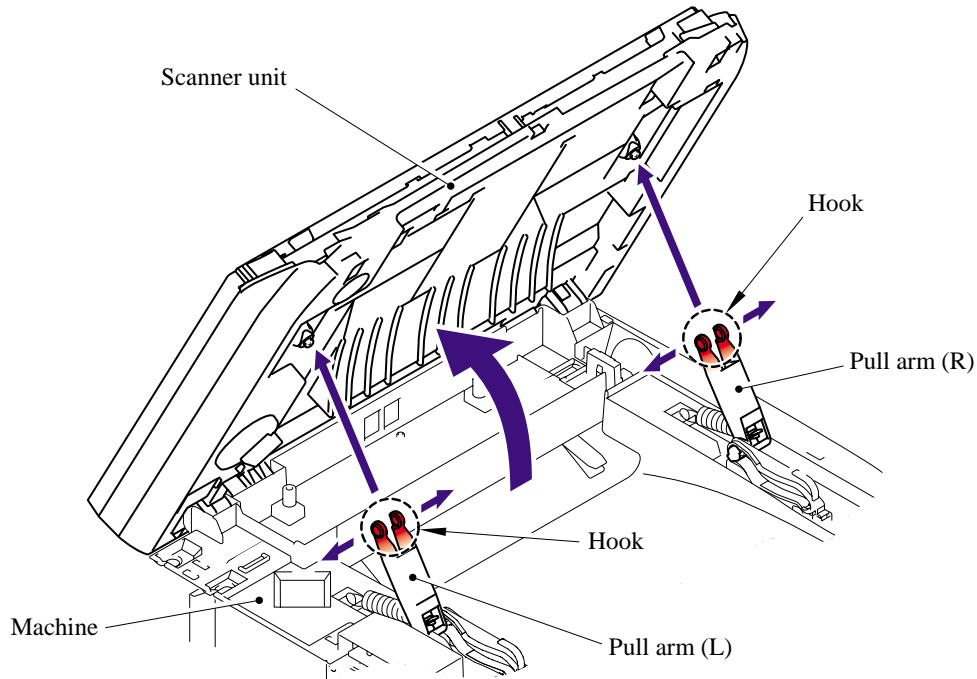

- (3) Remove the pull arm springs and remove the pull arms (R, L) from the pull arm guides.

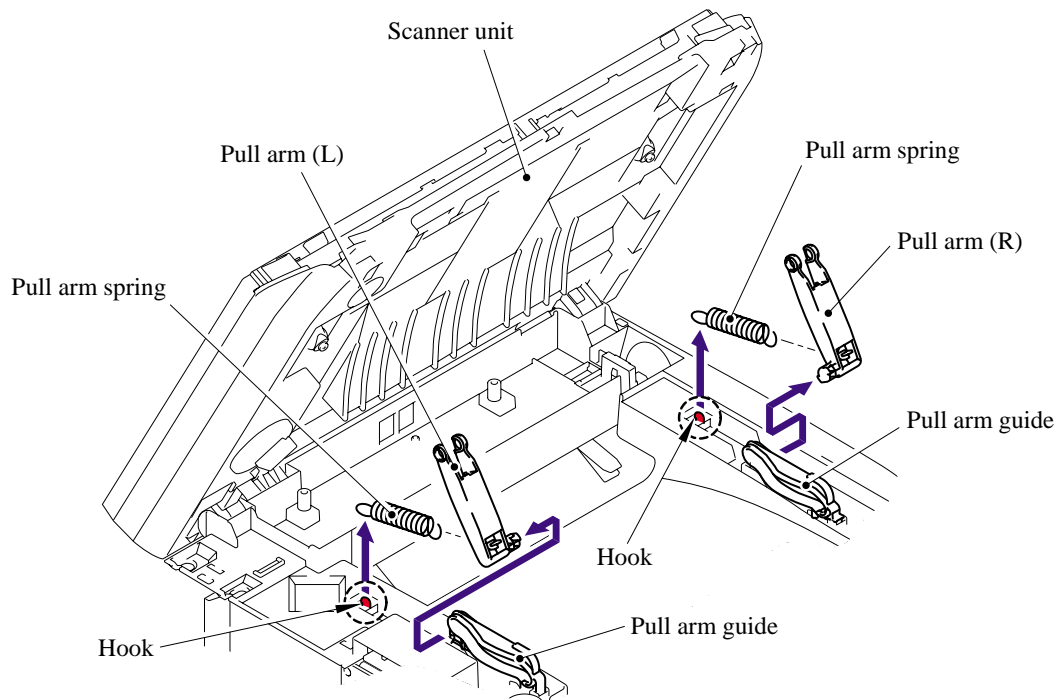

5.1.10 Scanner Unit

- (1) Disconnect the flat cable from the main PCB.
- (2) Remove the scanner unit from the machine.

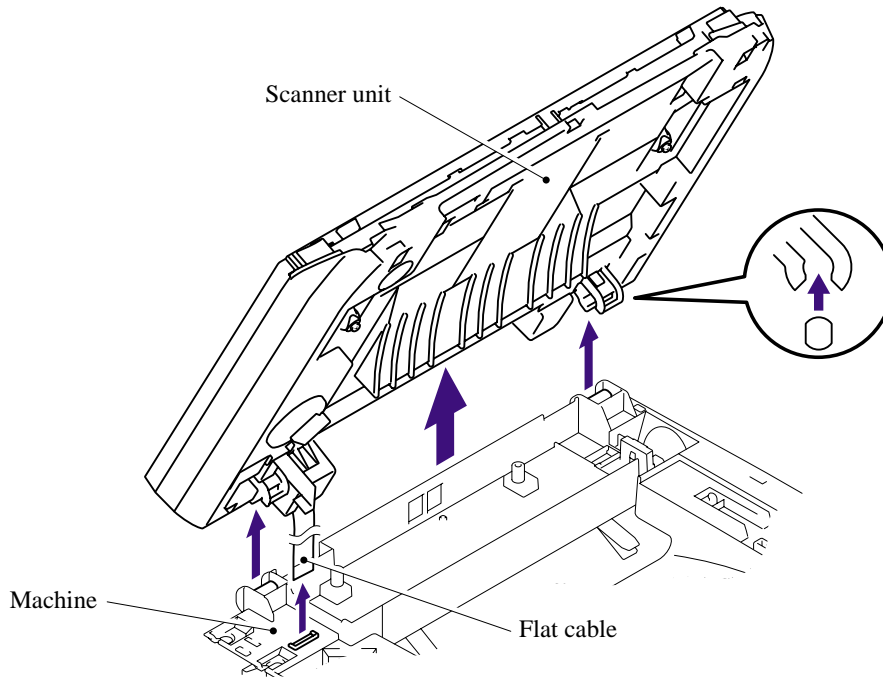

5.1.11 Panel Unit

- (1) Remove the four cup B M3x10 taptite screws from the scanner unit.
- (2) Release the four hooks.

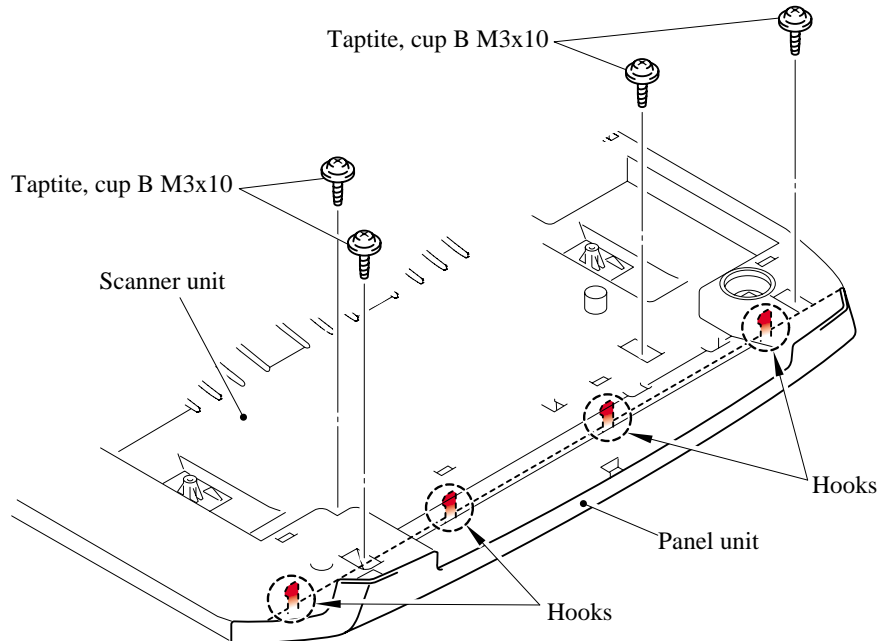

- (3) Disconnect the connector from the panel PCB ASSY.
- (4) Release the three hooks to remove the panel unit from the scanner unit.

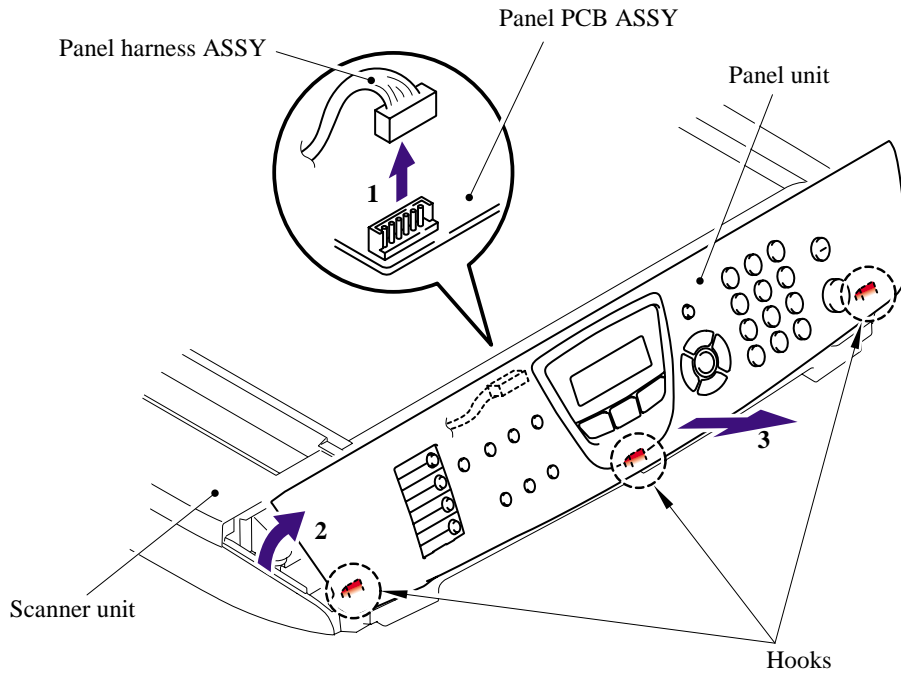

- (5) Remove the LCD harness from the panel PCB.
- (6) Release the three hooks "A" to remove the panel PCB from the panel cover.

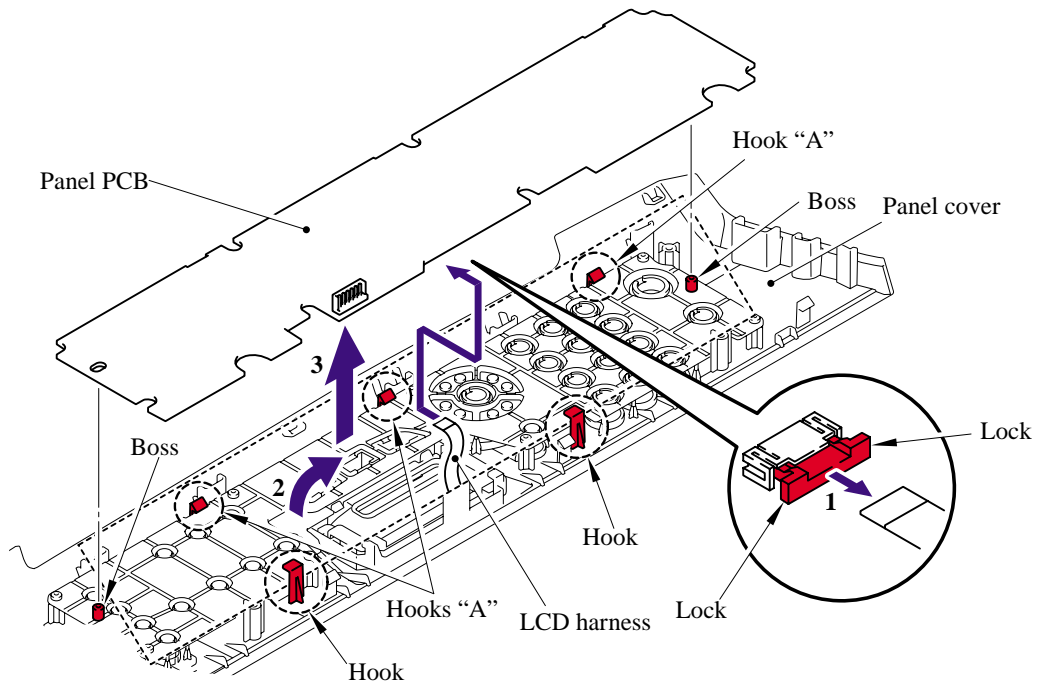

(7) Remove the rubber key.

NOTE: When re-assembling the rubber key, make sure that the key works correctly.

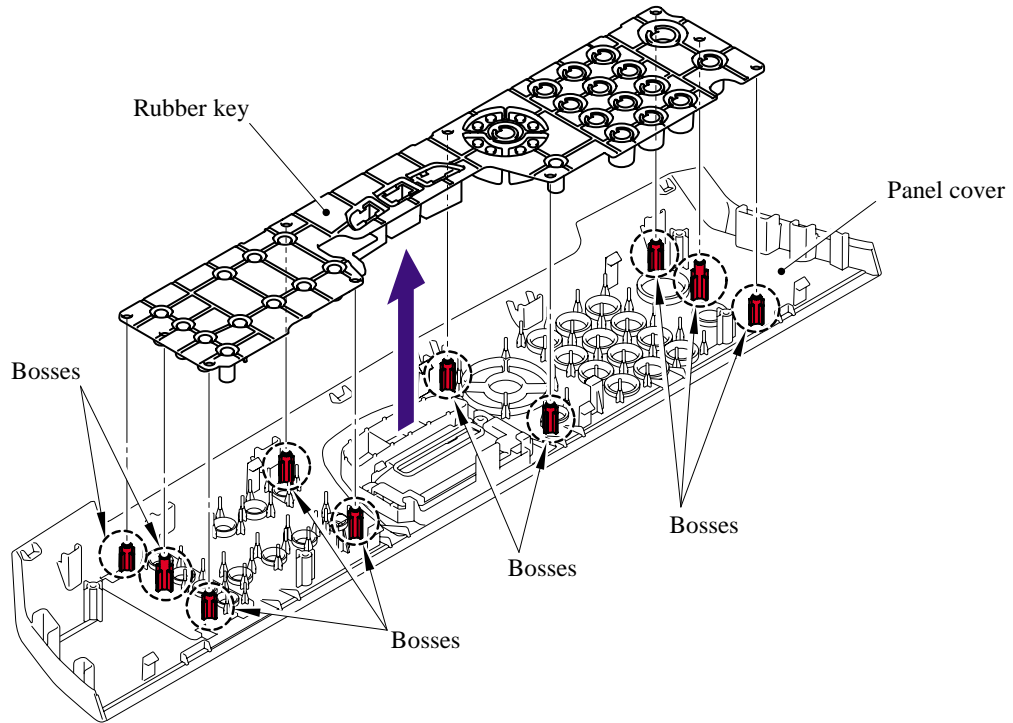

(8) Release the two hooks "A" to remove the backlight guide.

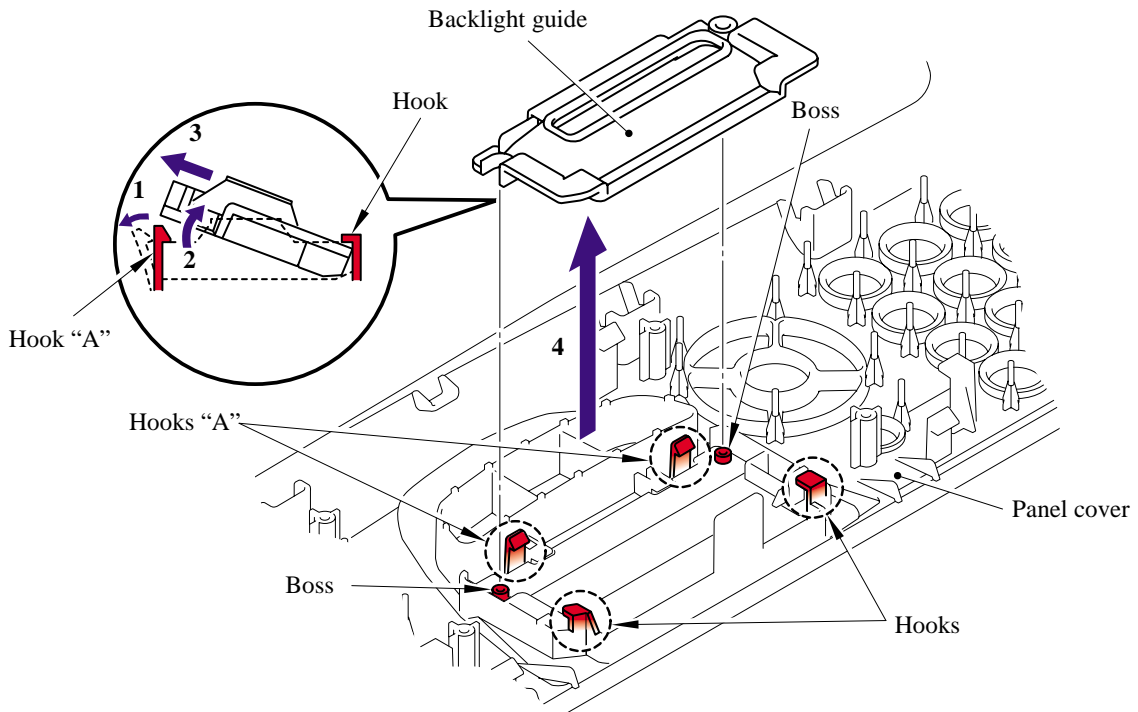

(9) Remove the diffusion film.

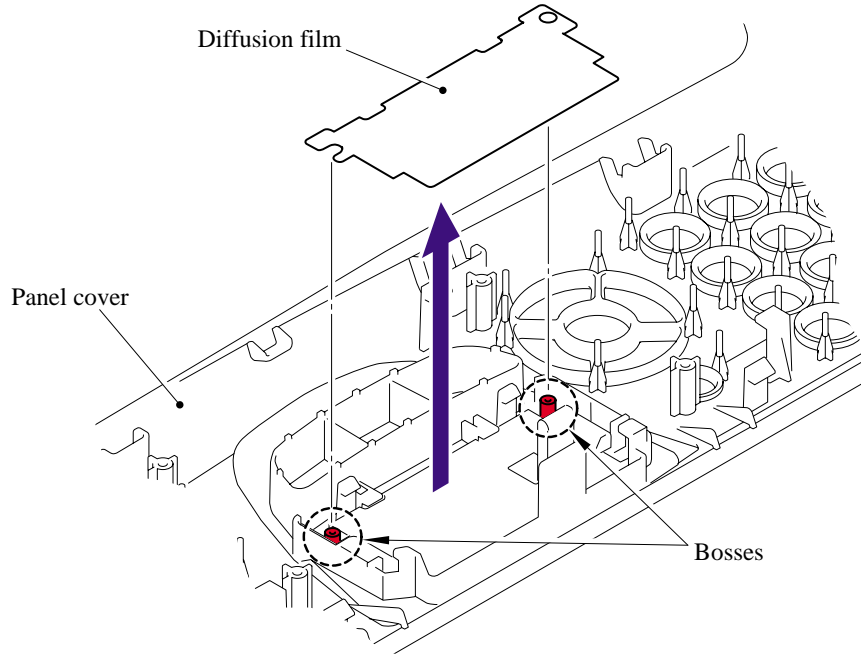

(10) Release the two hooks "A" to remove the LCD.

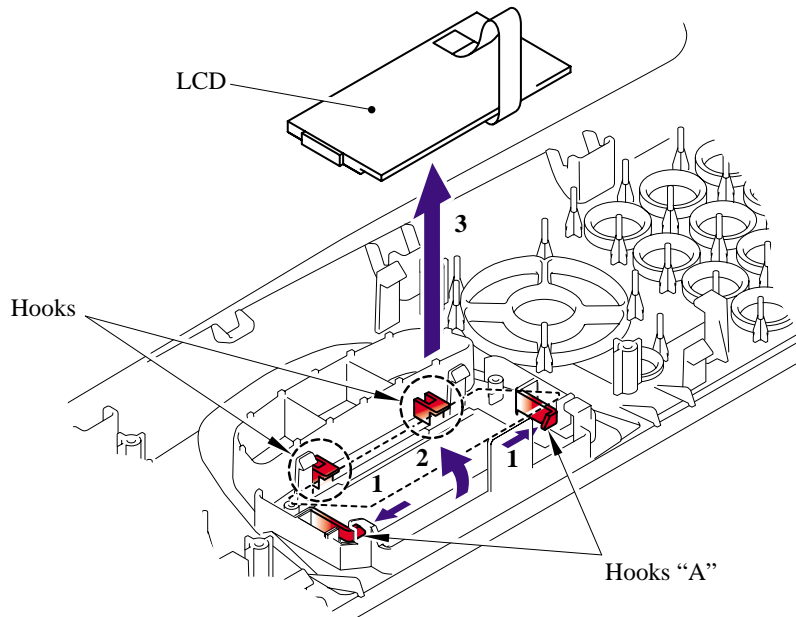

5.1.12 NCU PCB

- (1) Remove the two bind B M4x12 taptite screws and one pan (S/P washer) M3.5x6 screw from the NCU unit.

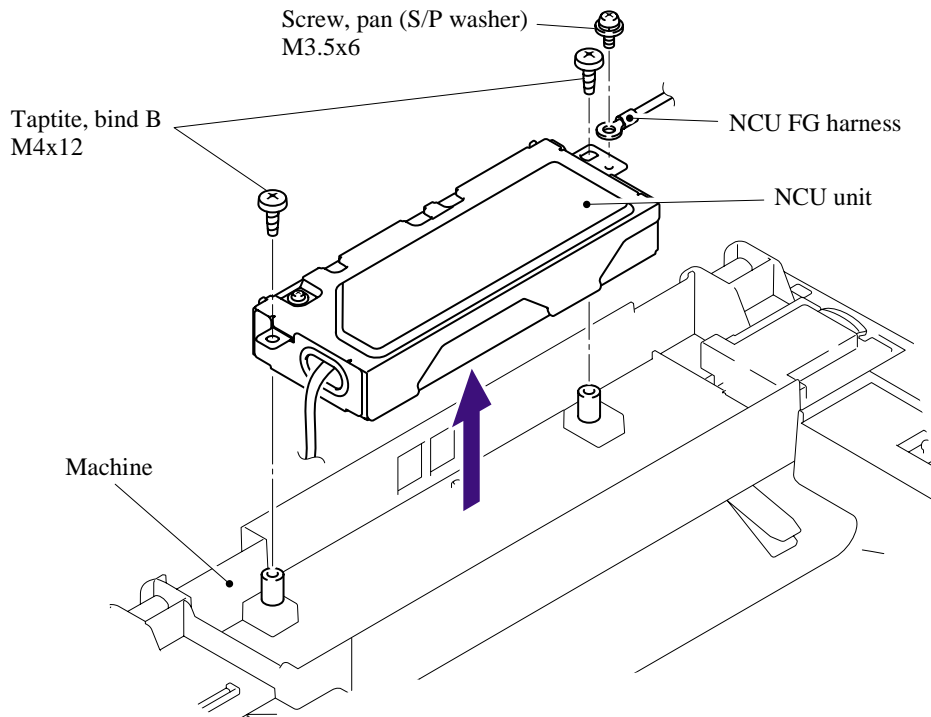

- (2) Remove the one pan (S/P washer) M3.5x6 screw from the NCU shield cover to remove the NCU shield plate.

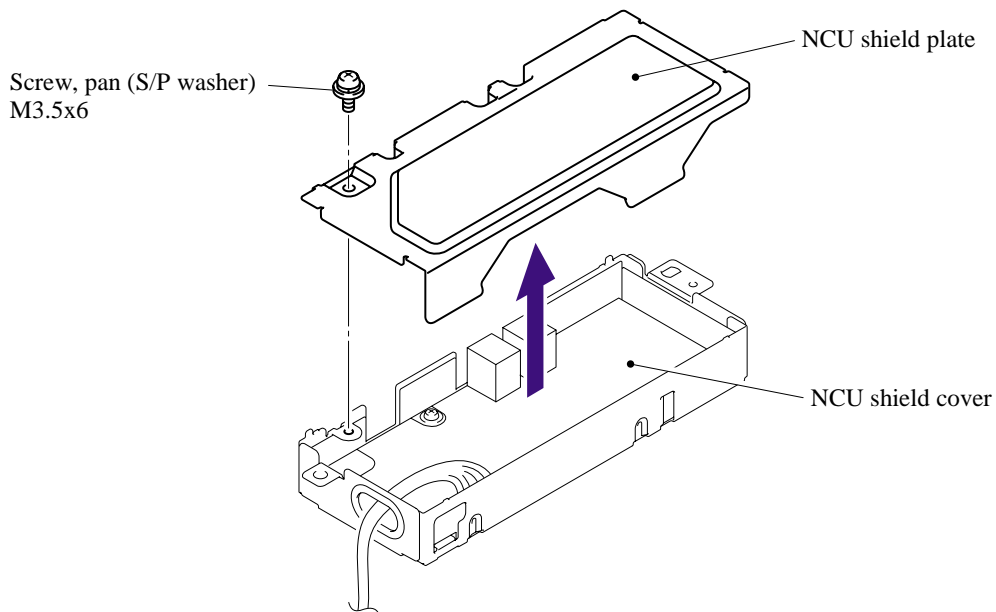

- (3) Remove the NCU harness ASSY.
- (4) Remove the two cup S M3x6 taptite screws from the NCU shield cover to remove the NCU PCB ASSY.

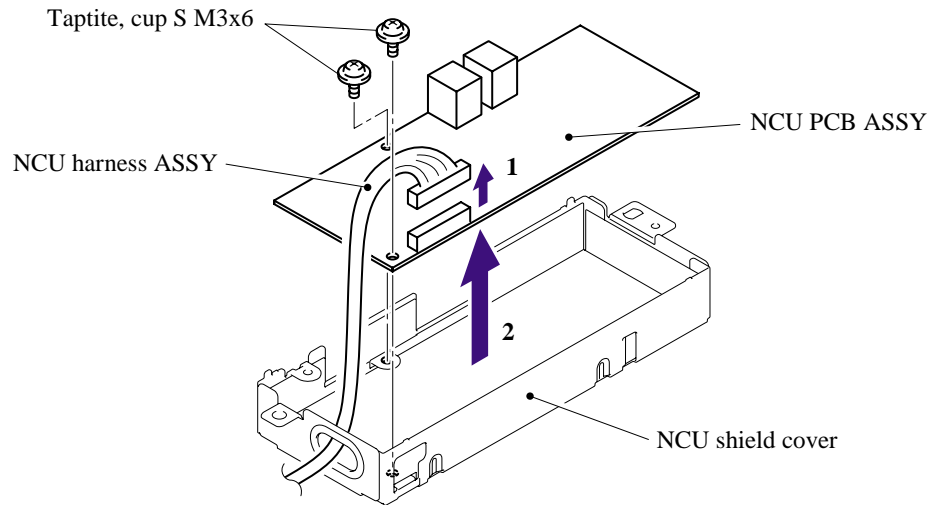

5.1.13 Speaker

- (1) Disconnect the connector of the speaker from the main PCB.

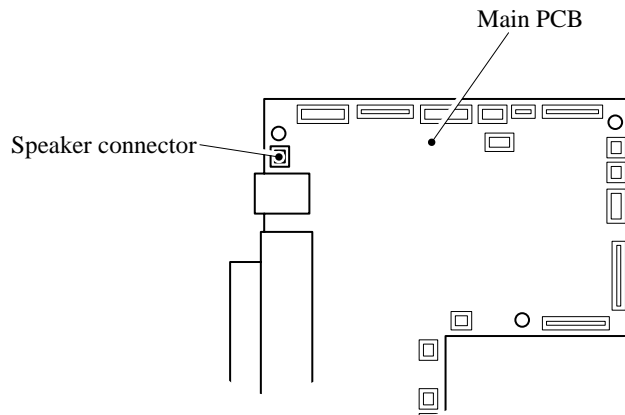

(2) Release the three hooks to remove the speaker cover.

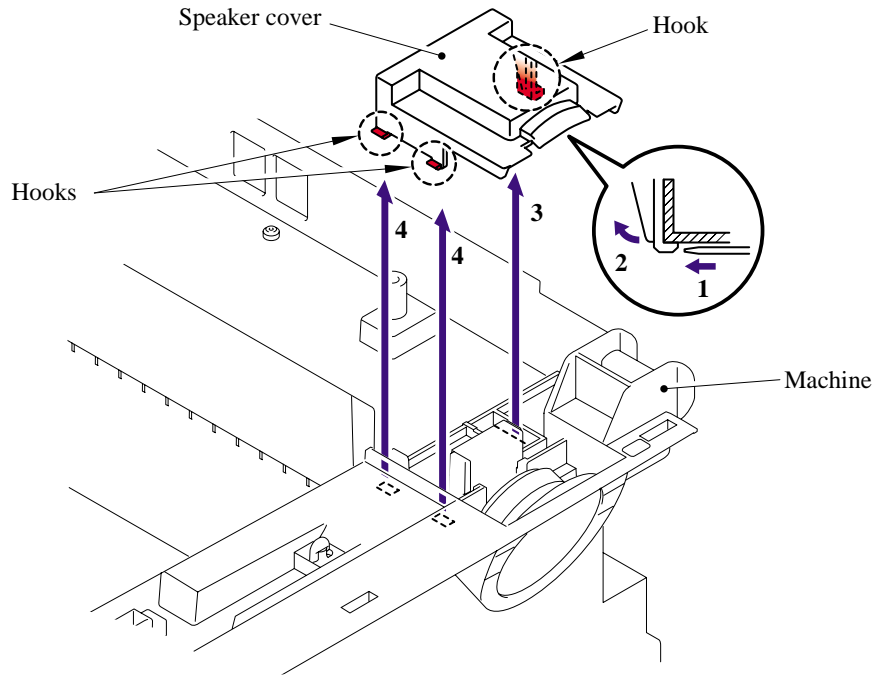

(3) Release the one hook to remove the speaker hold spring.

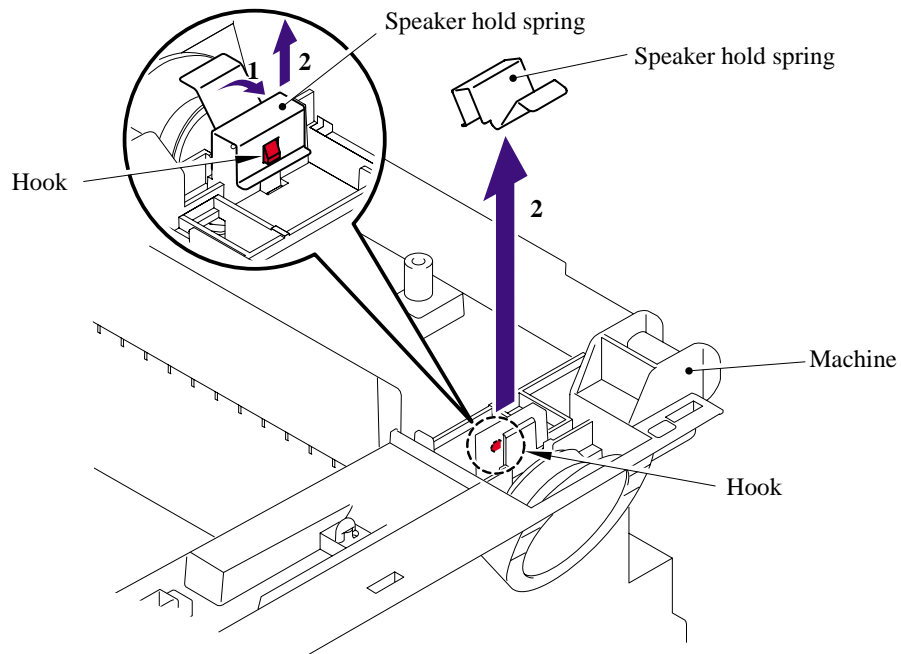

(4) Remove the speaker ASSY.

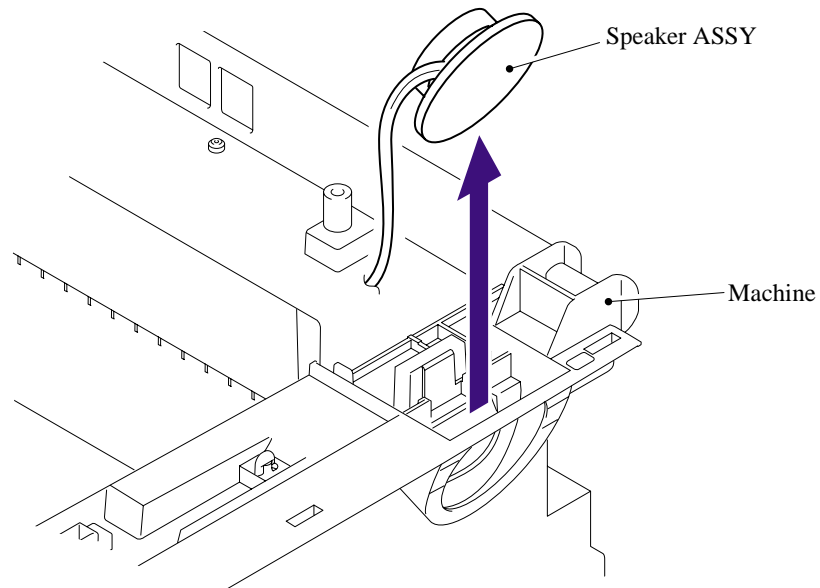

5.1.14 Joint Cover ASSY /Paper Stopper/Battery ASSY

(1) Remove the bind B M4x12 taptite screw, and then remove the rear cover stopper.

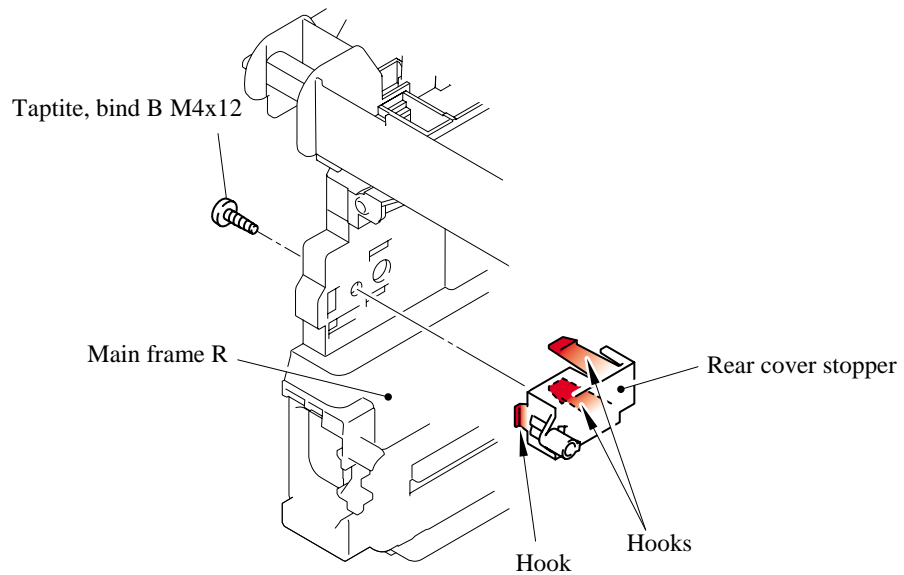

- (2) Remove the two bind B M4x12 taptite screws and the rear chute cover spring.
- (3) Remove the inner chute.

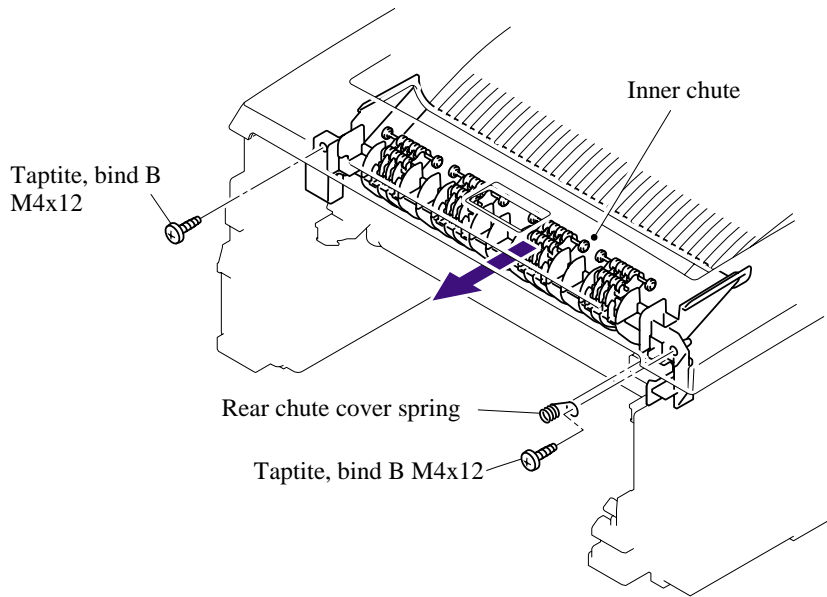

NOTE: Re-assemble the inner chute while pushing onto the pinch roller of the inner chute with the eject roller of the joint cover ASSY.

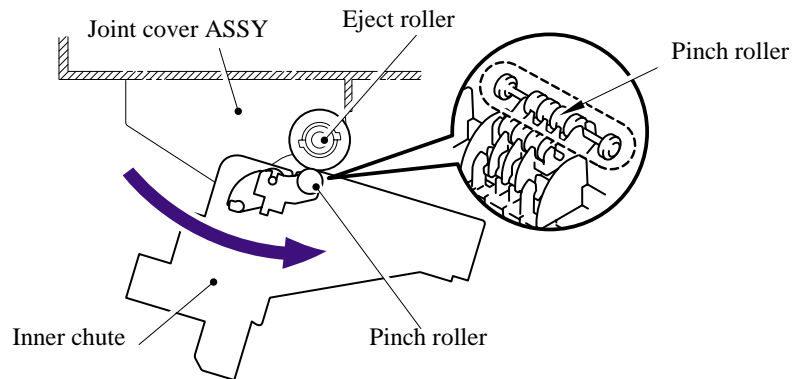

(4) Remove the battery ASSY and disconnect the connector.

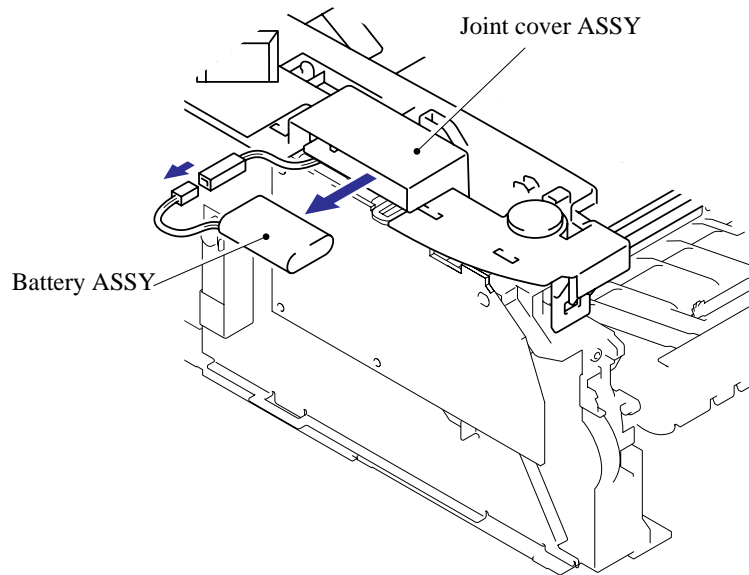

CAUTION:

- There is a danger of explosion if the battery is incorrectly replaced.
- Do not replace the battery.
- Do not disassemble, recharge or dispose of in fire.
- Used battery should be disposed of according to local regulations.

(5) Remove the four bind B M4x12 taptite screws, and then remove the joint cover ASSY.

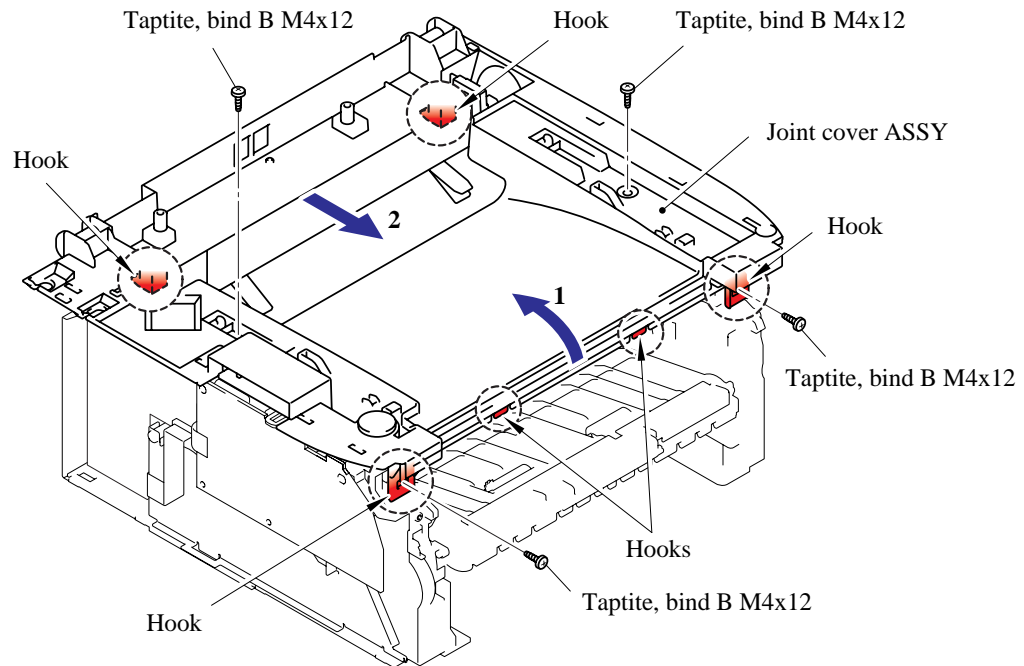

5.1.15 Front Cover

- (1) Release the hook of the drive release cam from the front cover ASSY.

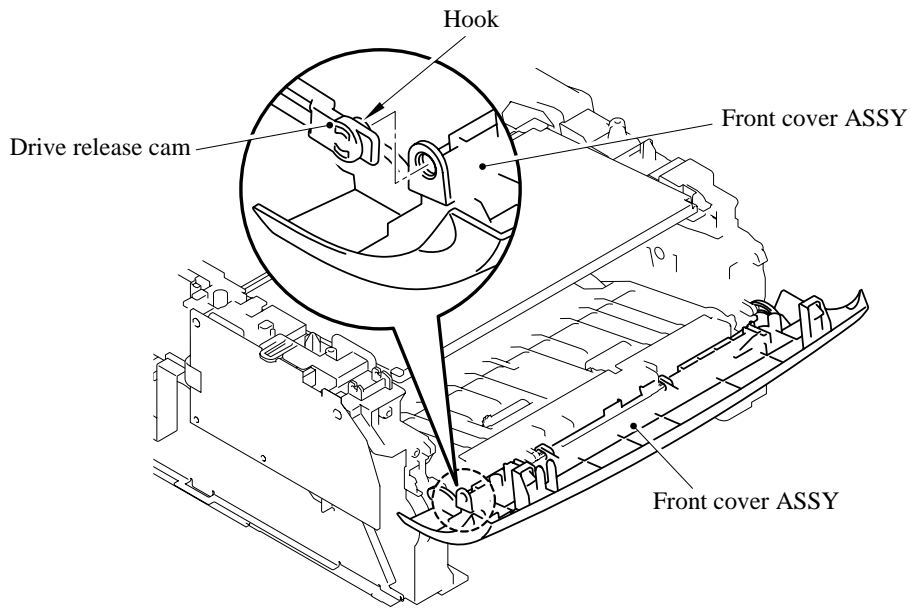

- (2) Release the hook "A" on the front cover ASSY from the chute.
- (3) Slide the front cover ASSY to the direction of the arrow shown in the figure below to remove it.

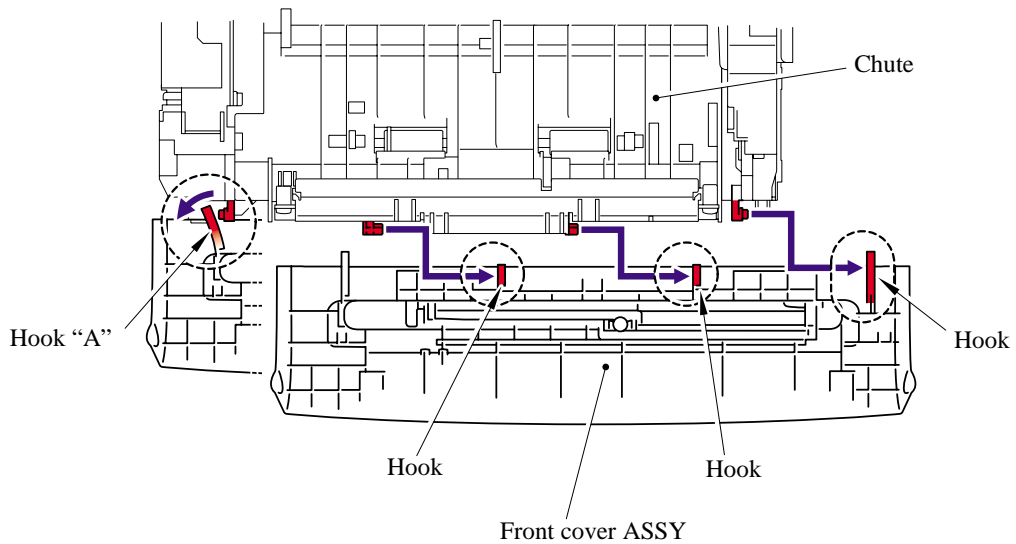

(4) Remove the paper stopper L.

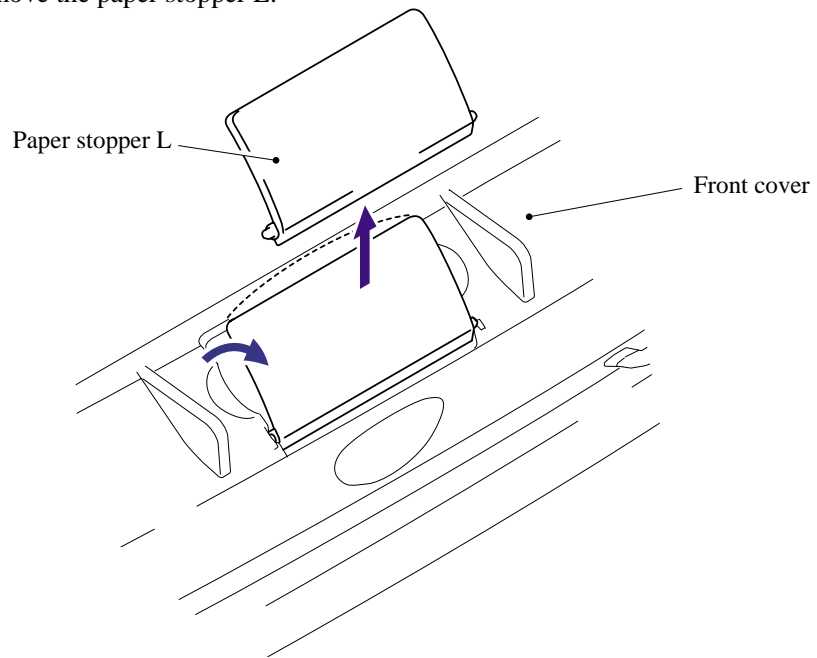

(5) Remove the paper stopper S from the paper stopper L.

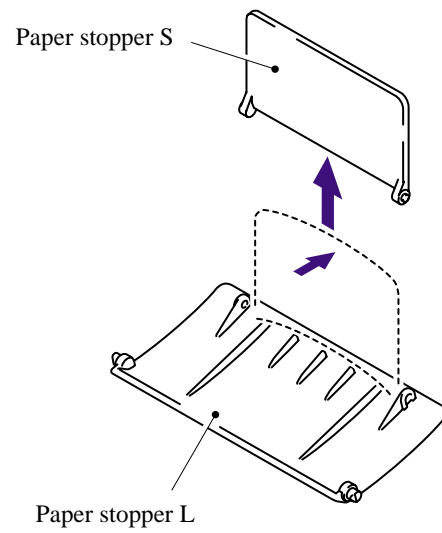

5.1.16 Pickup Roller Holder ASSY

- (1) Turn the printer upside down.
- (2) Remove the six bind B M4x12 taptite screws, and then remove the chute base.

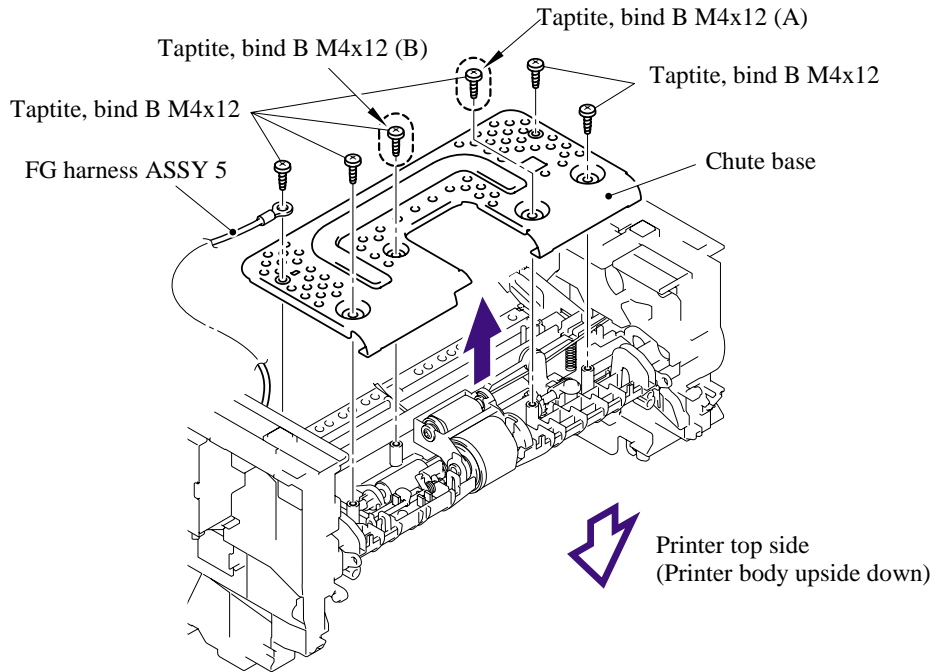

NOTE: When re-assembling the chute base, check that the bind B M4x12 taptite screws (A) and (B) shown in the figure above are secured correctly.

<How to check>

Take the Drum/Toner Unit out from the printer. Check that the distance between the floor and the separation roller collar of the pickup roller holder ASSY is 45.5 to 47.5mm by using the plate jig. If not, re-assemble the chute base.

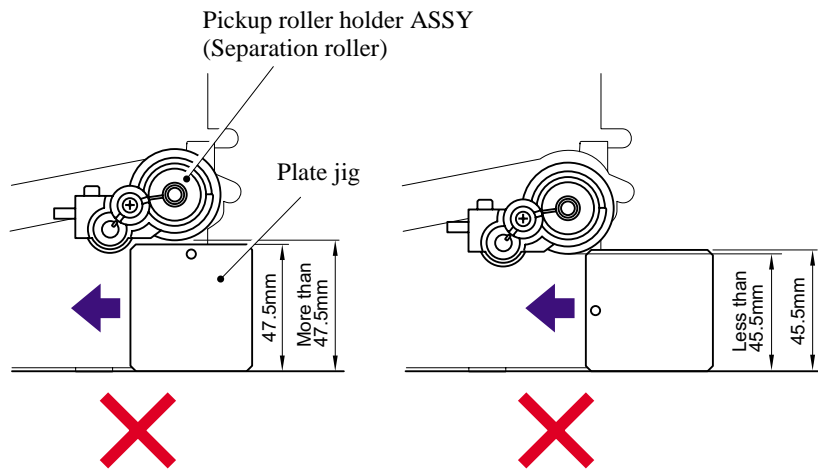
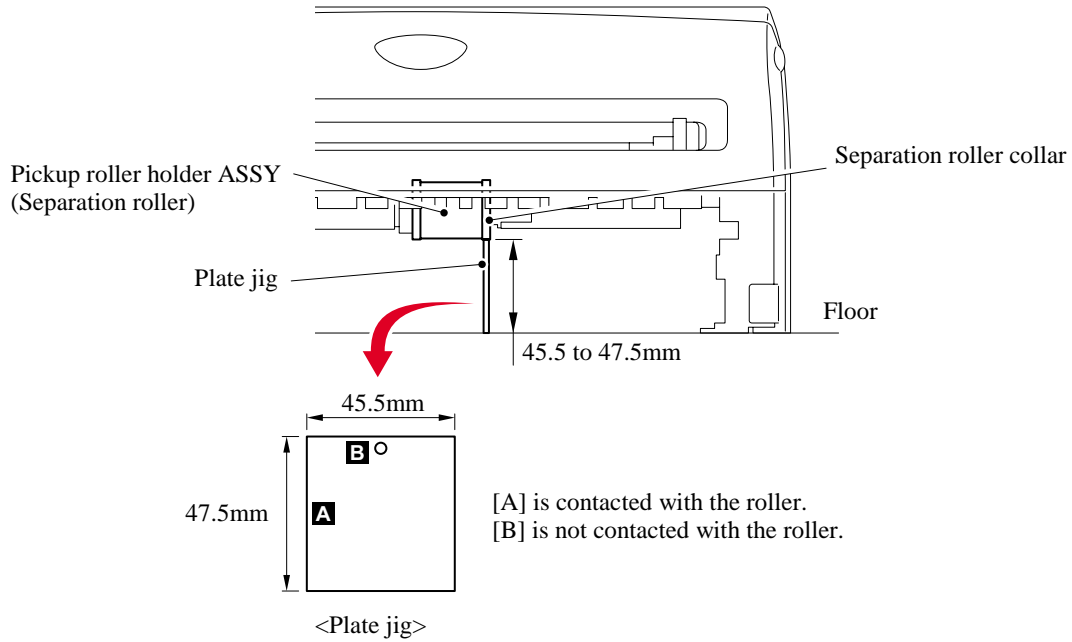

- (3) Remove the spring extension P/R from the gear 52 P/R.
- (4) Release the hook and remove the gear 52 P/R.

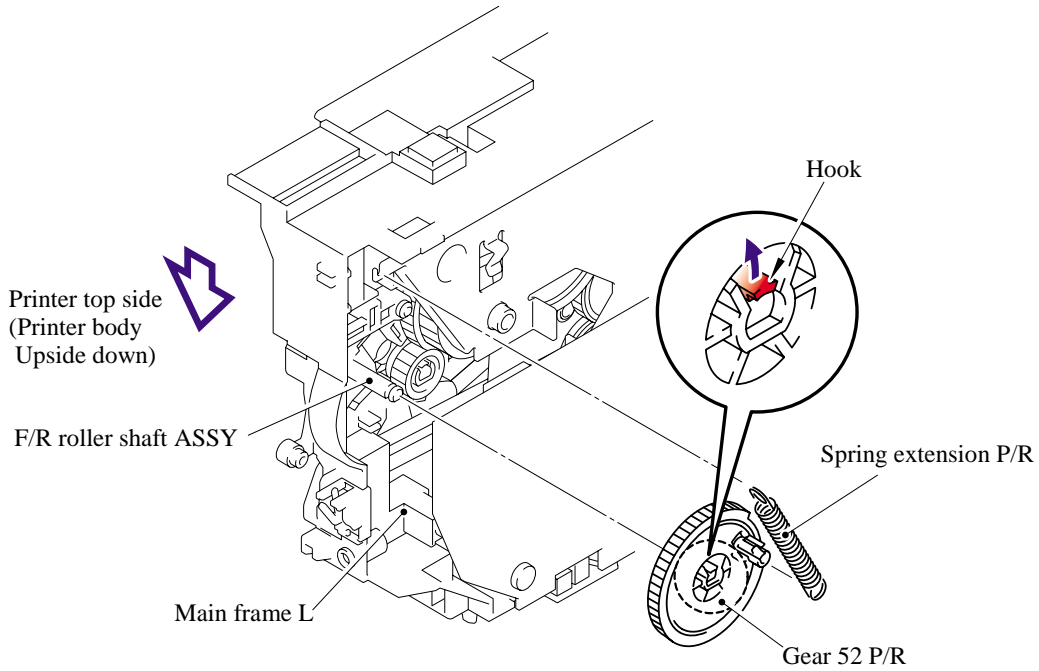

- (5) Remove the bush F/R.
- (6) Remove the F/R roller shaft ASSY.

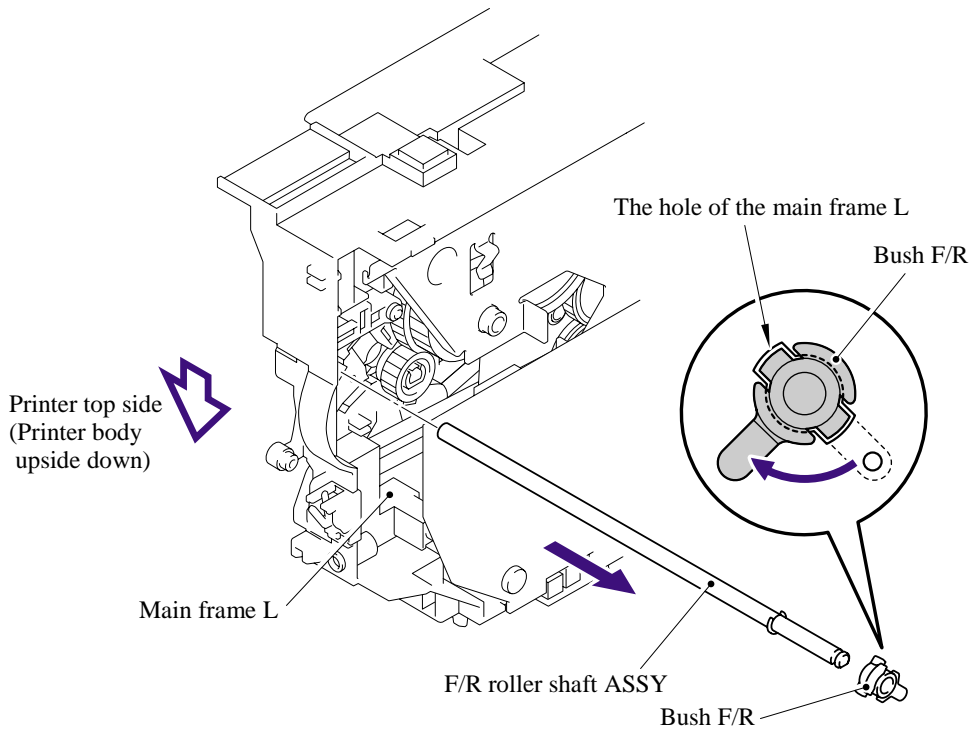

- (7) Remove the link lever from the hook of the pickup roller holder ASSY.
- (8) Remove the pickup roller holder ASSY.

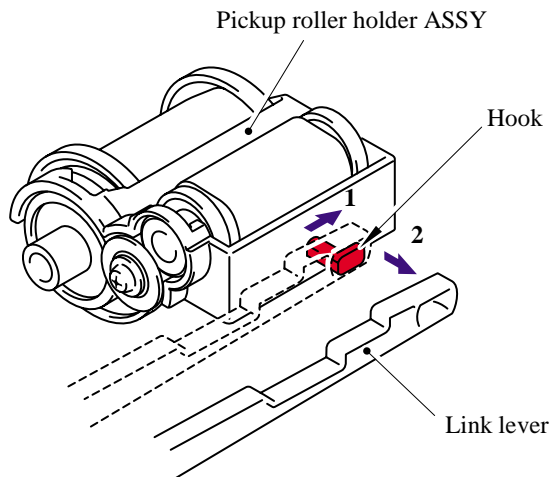
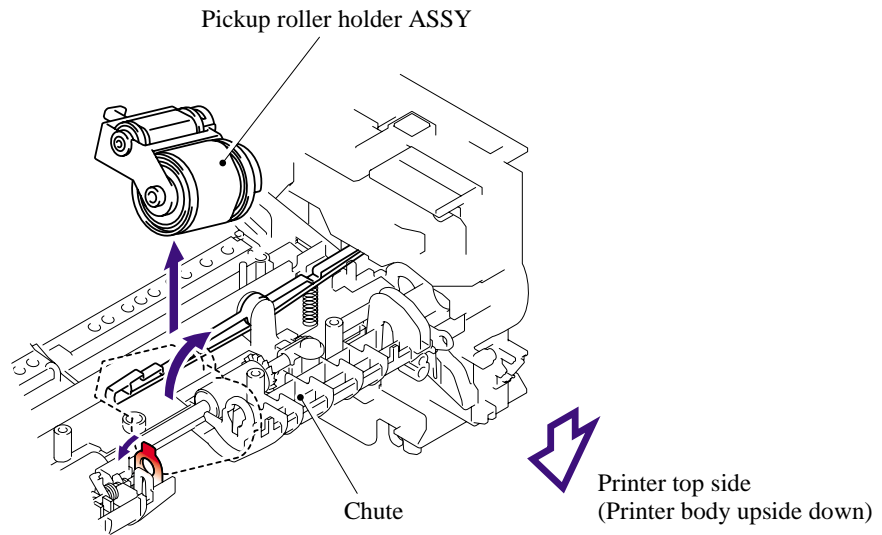

NOTE: The pickup roller holder spring is assembled on the bottom of the pickup roller holder ASSY. Be careful not to lose the spring.

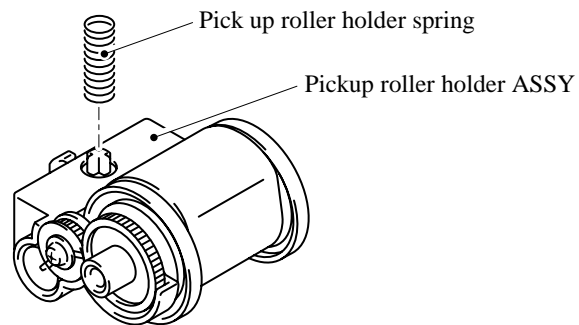

5.1.17 Fixing Unit

- (1) Disconnect the heater harness connector and thermistor harness connector.
- (2) Remove the two cup B M4x12 taptite screws, and then remove fixing unit.

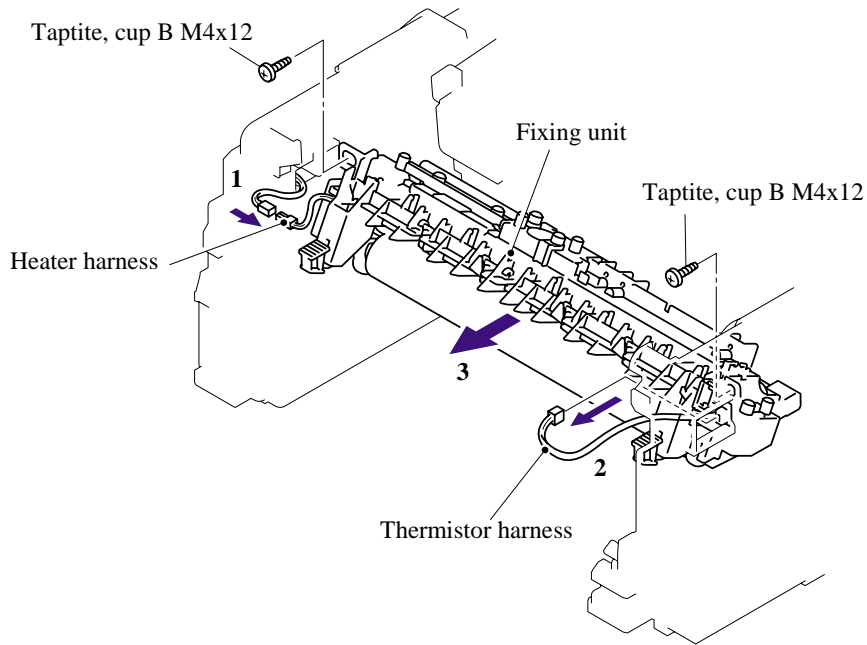

NOTE: Be sure not to touch the pressure roller.

- (3) Remove the two PR spring.
- (4) Remove the pressure roller ASSY (pressure roller, PR arm ASSY, PR bush) from the fuser frame.

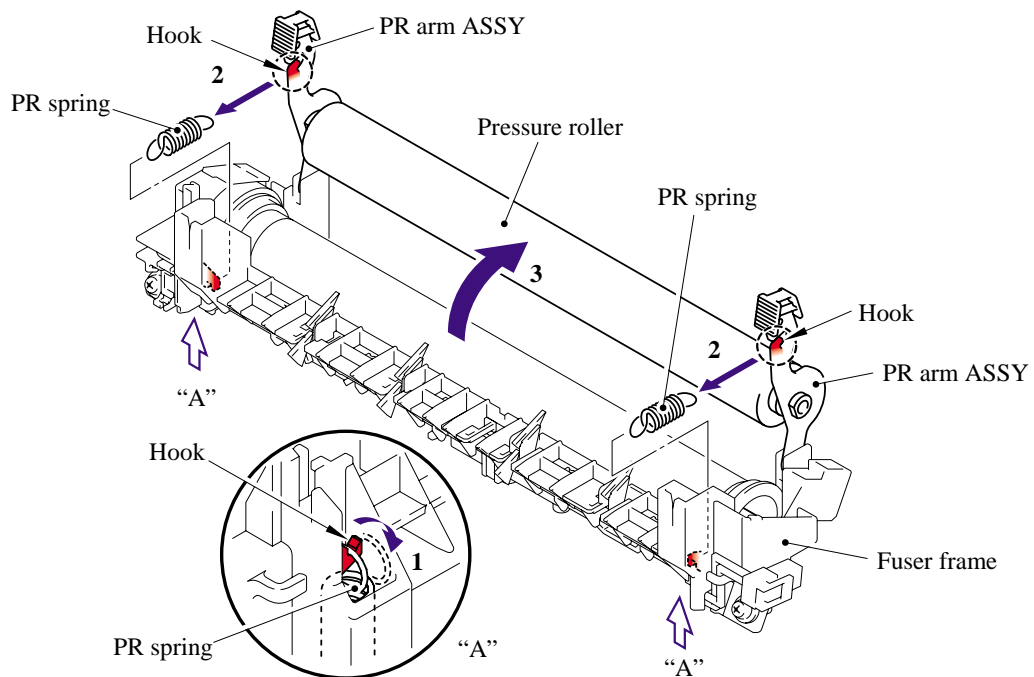

- (5) Remove the two PR arm ASSY and two PR bush from the pressure roller.

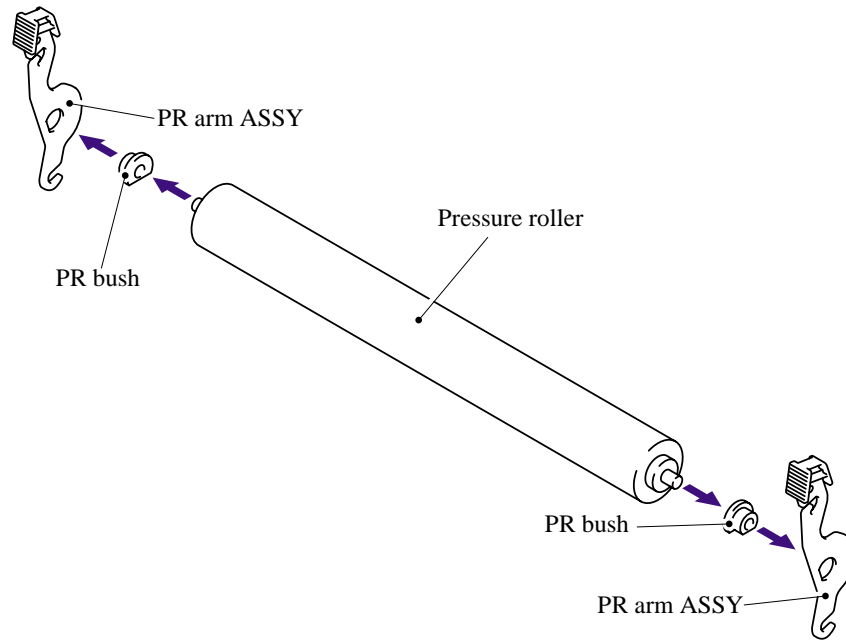

- (6) Release each hook of the springs from the fuser frame and remove the four separate claw ASSYs.

NOTE: Be careful not to damage the heat roller when removing the separate claw ASSY.

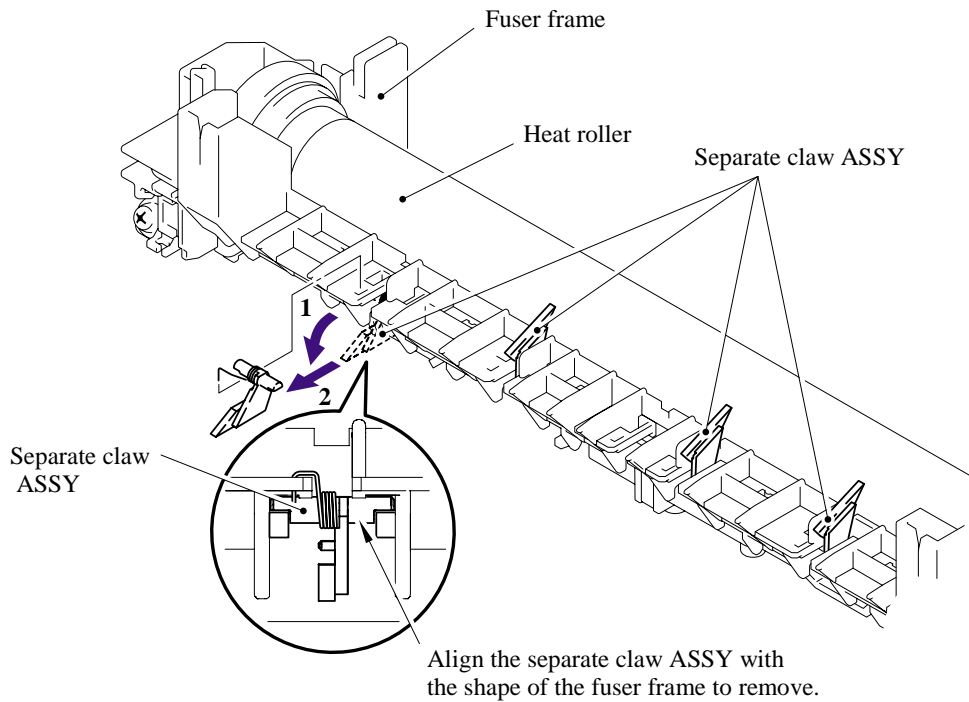

- (7) Remove the two pan (S/P washer) M3x8 screws.
- (8) Remove the heat roller.
- (9) Remove the halogen heater.

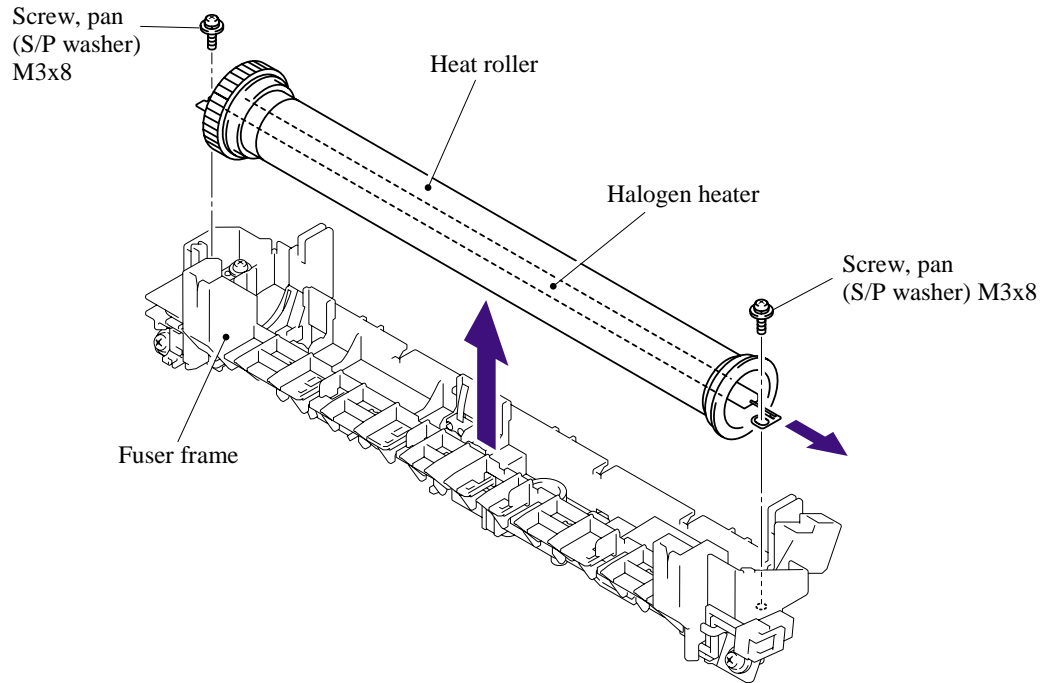

NOTE: When re-assembling the heat roller, assemble the HR bush onto the fuser frame referring to the figure below.

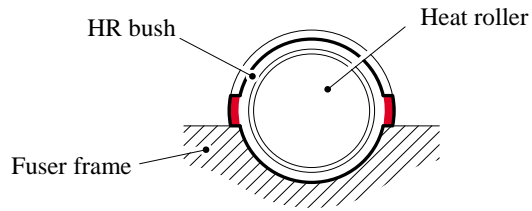

NOTE: When re-assembling the halogen heater, put the halogen heater onto the fuser frame so that the terminal of the heater harness is at the top, and secure the screws in the order shown in the figure below.

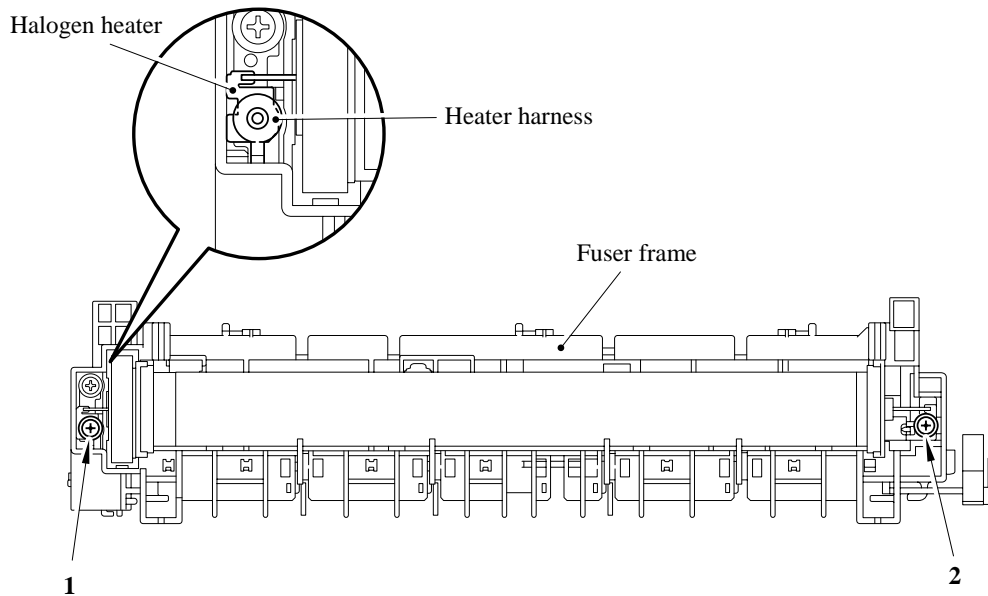

- (10) Remove the HR gear.
- (11) Remove the two HR bush.

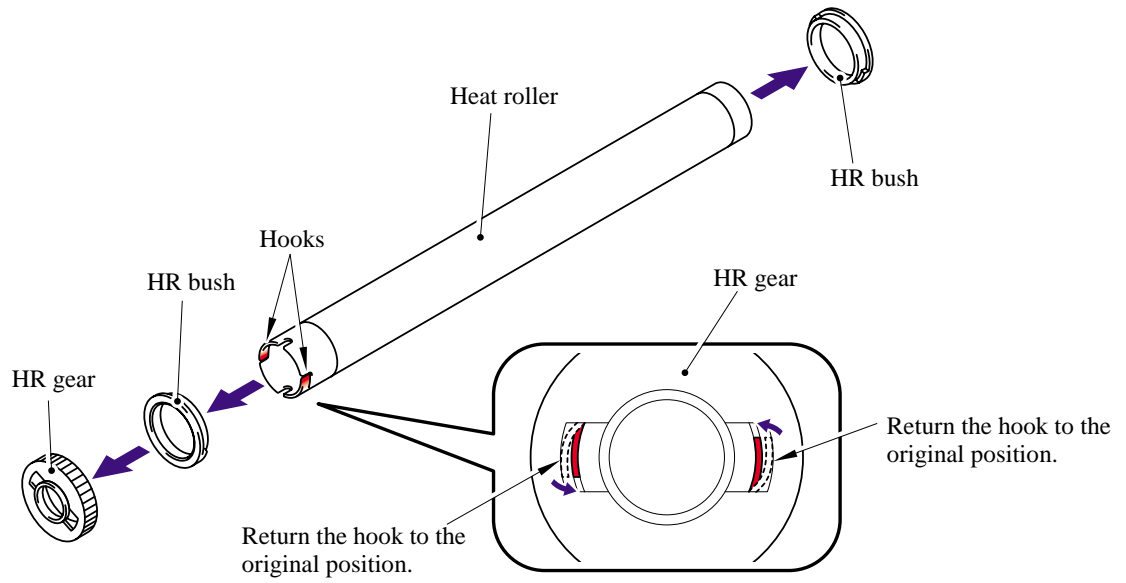

- (12) Remove the thermistor ASSY harness from the four hooks.
- (13) Remove the cup B M3x12 taptite screw, and then remove the thermistor ASSY.

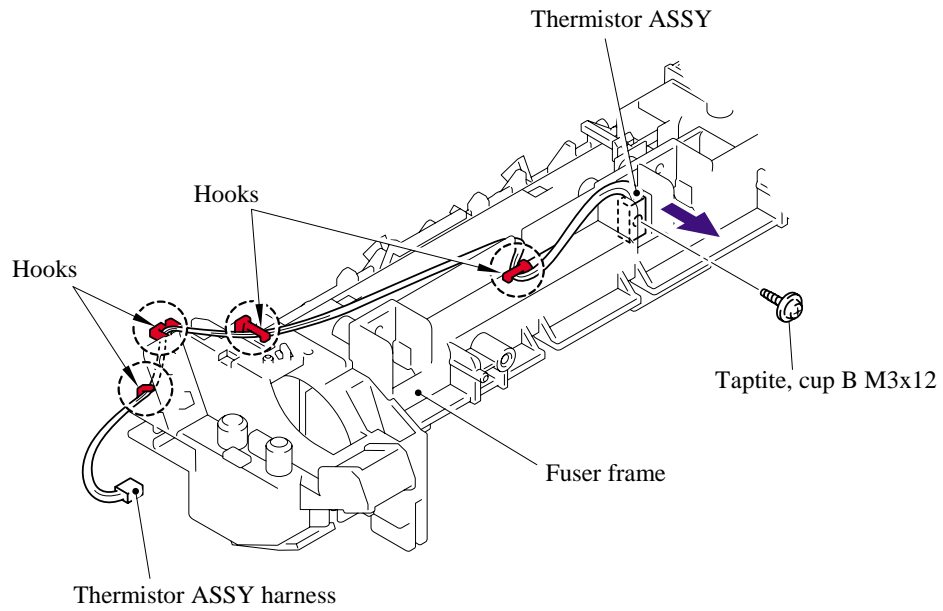

NOTE: When re-assembling the thermistor ASSY to the fuser frame, ensure the direction of the thermistor ASSY is correct referring to the figure below;

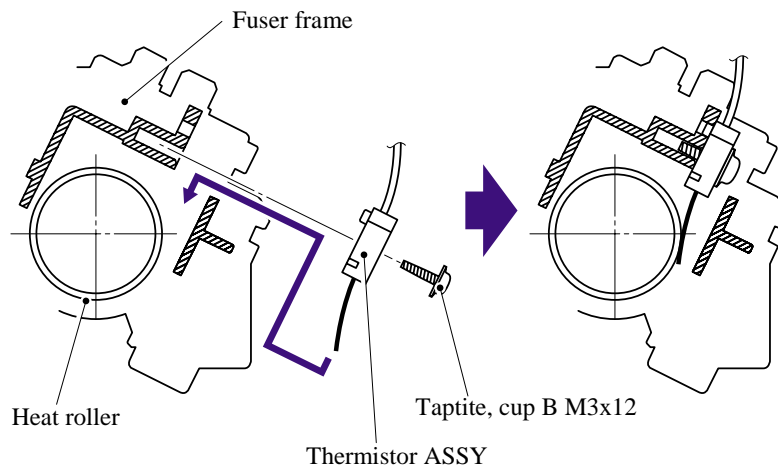

5.1.18 High-Voltage PS PCB ASSY

- (1) Disconnect the three connectors from the high-voltage PS PCB ASSY.
- (2) Disconnect the high-voltage PS PCB harness from the main PCB.

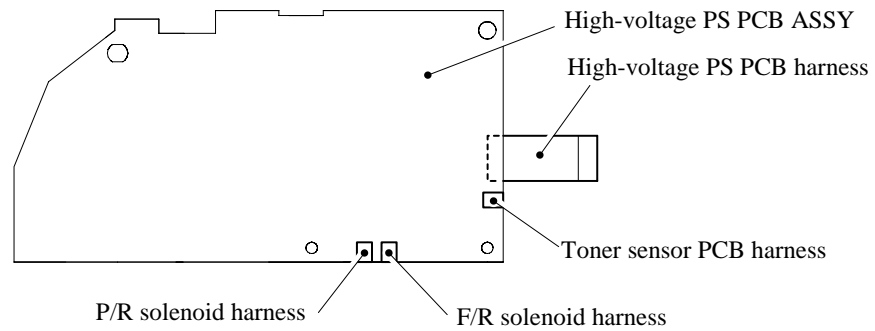

- (3) Remove the two bind B M4x12 taptite screws and the two cup S M3x6 taptite screws.
- (4) Remove the high-voltage PS PCB from main frame L.

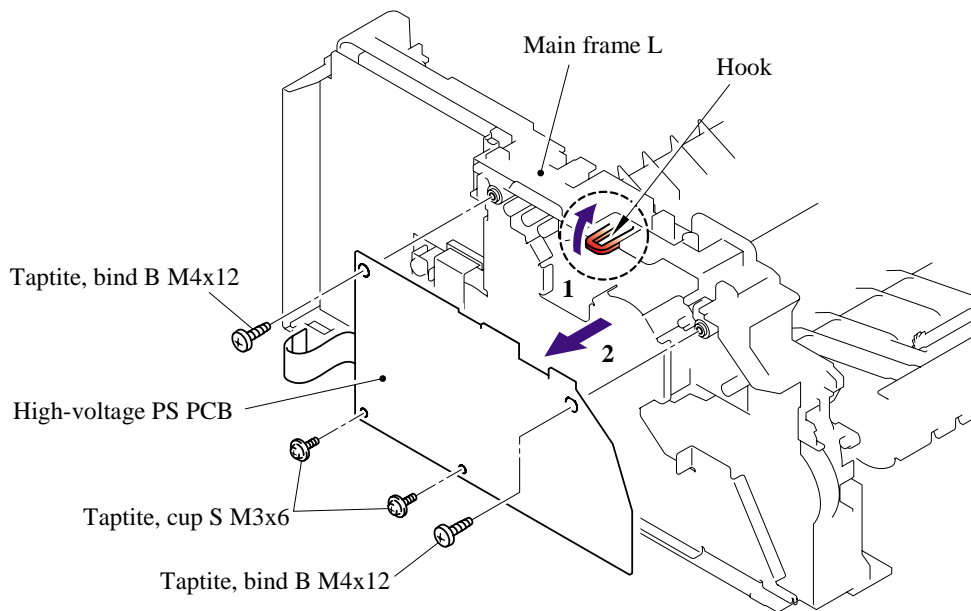

5.1.19 Main PCB

< DCP7010/7020/7025, MFC7420 >

- (1) Disconnect the thirteen connectors from the main PCB.

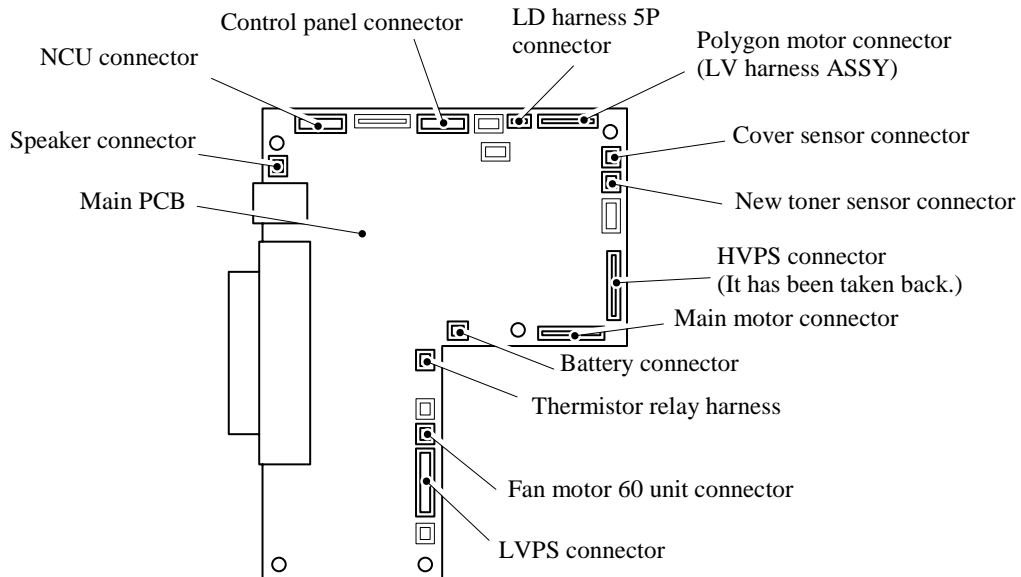

- (2) Remove the five cup S M3x6 taptite screws and FG harness ASSY 6.
- (3) Remove the two flat S M3x8 taptite screws.
- (4) Remove the main PCB from main frame L.

NOTE: When replacing the main PCB, refer to [‘ADJUSTMENTS AND UPDATING OF SETTINGS, REQUIRED AFTER PARTS REPLACEMENT’](#) in Chapter 6.

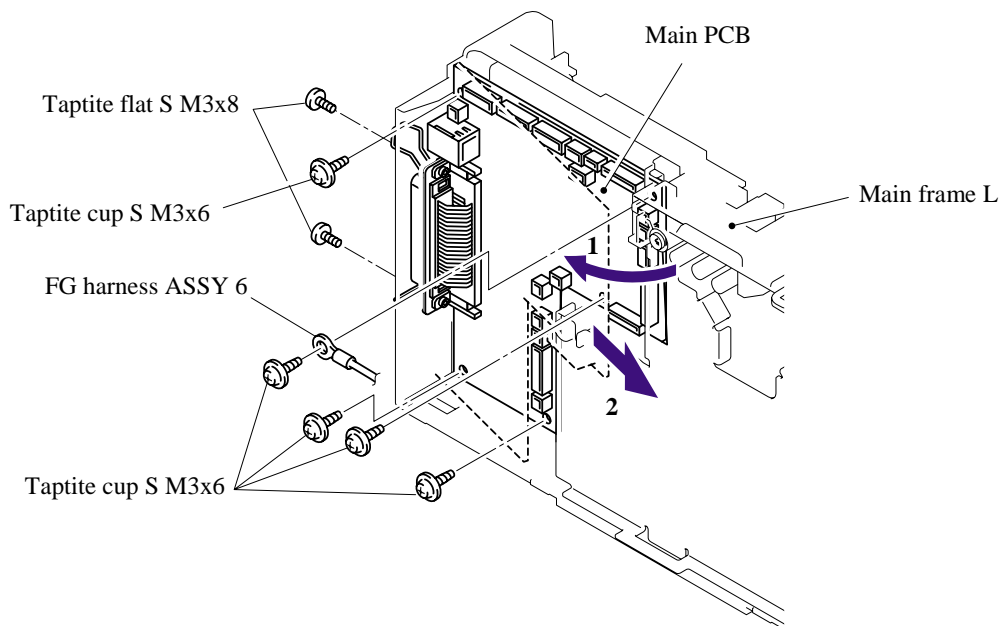

< MFC7820N >

(1) Disconnect the thirteen connectors from the main PCB.

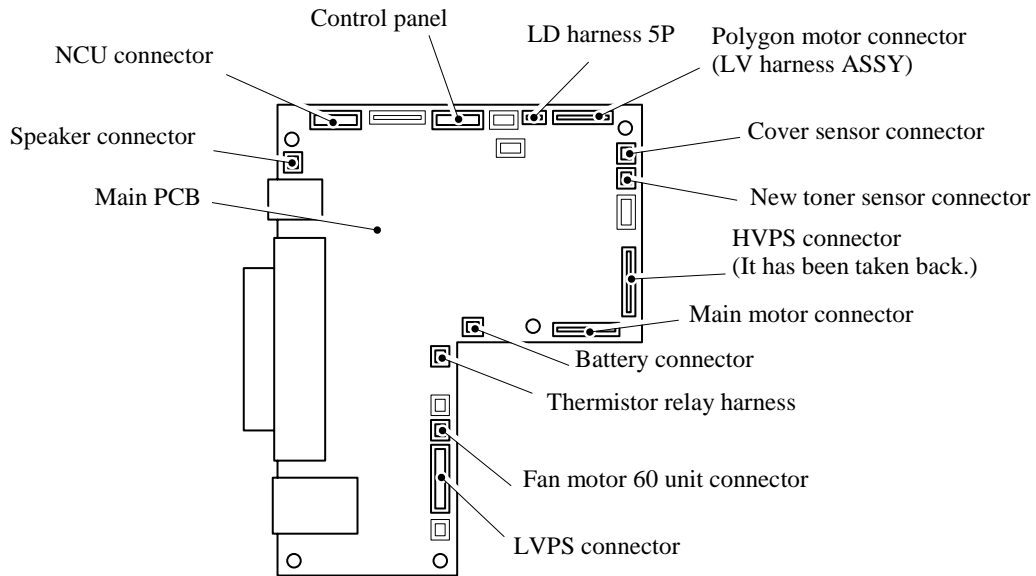

(2) Remove the five cup S M3x6 taptite screws and FG harness ASSY 6.

(3) Remove the two flat S M3x8 taptite screws.

(4) Remove the main PCB from main frame L.

NOTE: When replacing the main PCB, refer to 'ADJUSTMENTS AND UPDATING OF SETTINGS, REQUIRED AFTER PARTS REPLACEMENT' in Chapter 6.

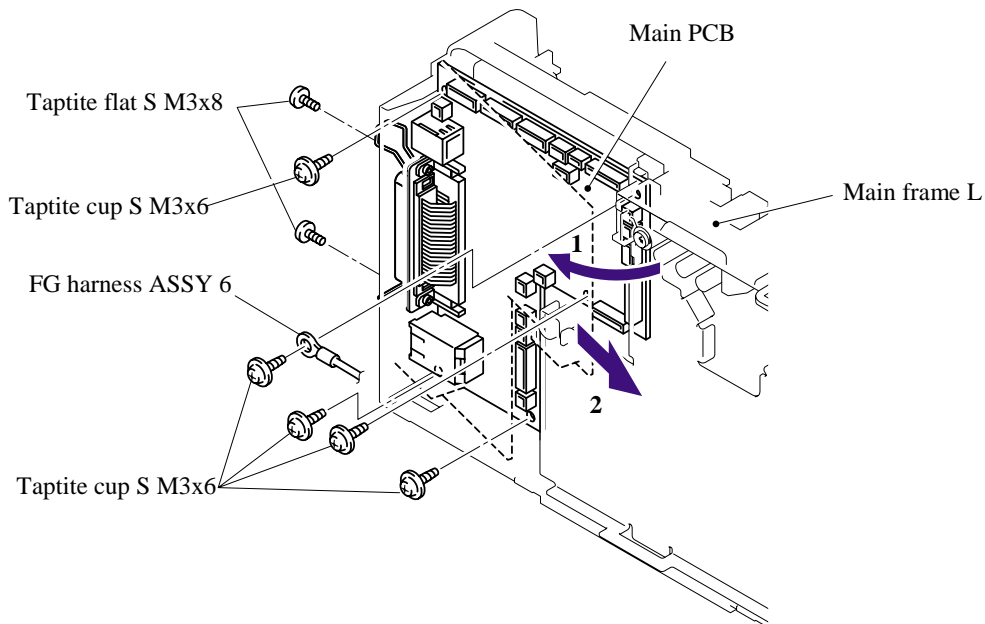

5.1.20 PS PCB Unit

- (1) Remove the duct film.
- (2) Remove the pan (S/P washer) M3.5 x 6 screw and FG harness ASSY 1.
- (3) Remove the pan (S/P washer) M3.5 x 6 screws and FG harness ASSY 5.
- (4) Remove the pan (S/P washer) M3.5 x 6 screws and NCU FG harness.
- (5) Remove the two cup S M3x6, taptite screws.
- (6) Remove the LV shield plate cover from the main frame R.

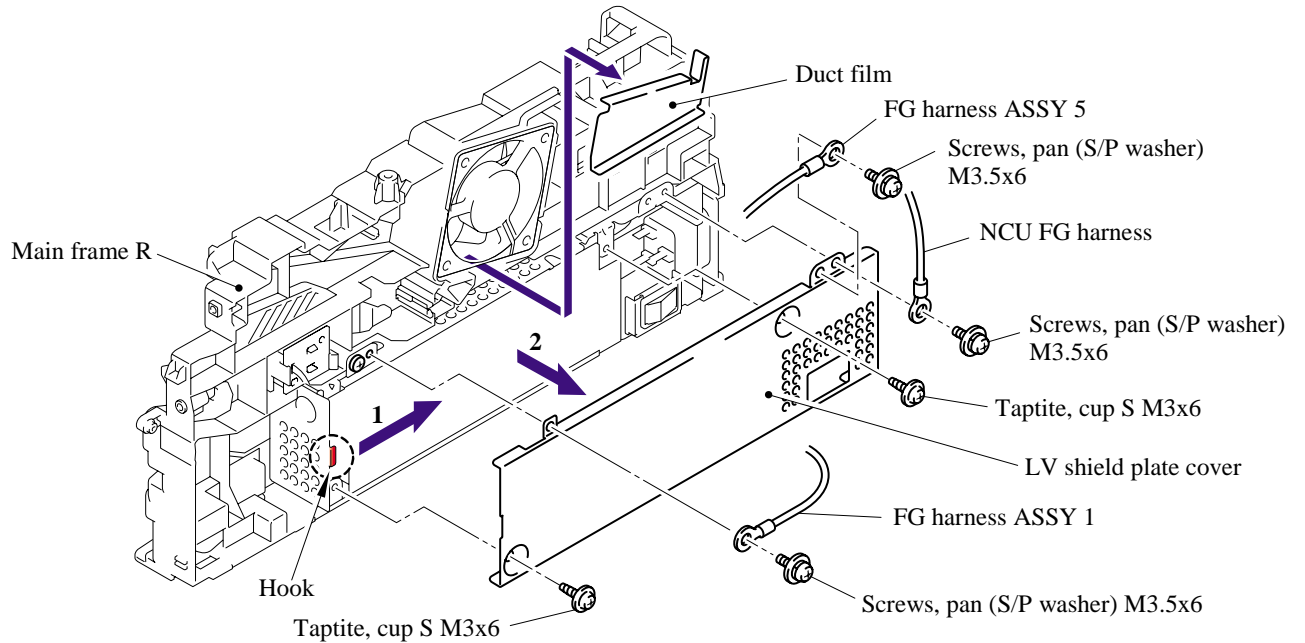

- (7) Remove the LV insulation sheet.

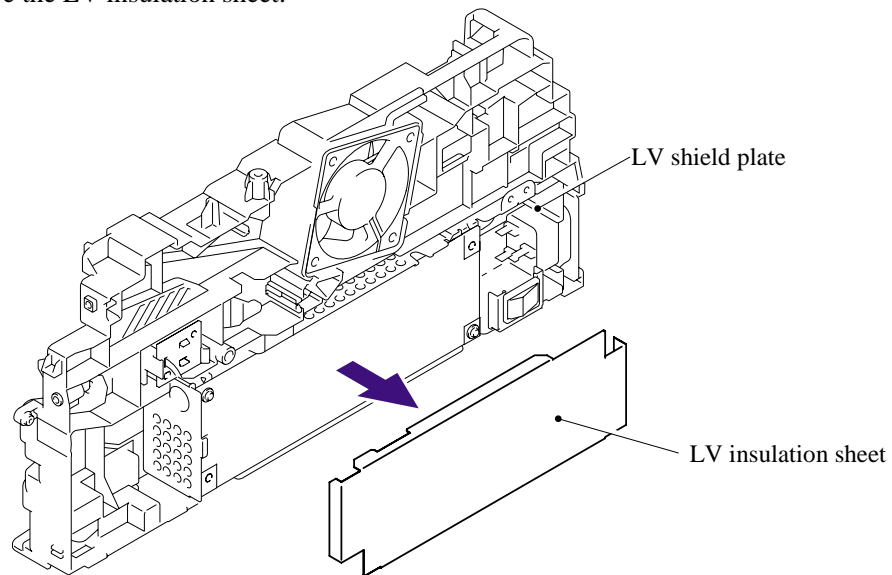

- (8) Remove the pan (S/P washer) M3.5x6 screw, and then remove the ground wire.
- (9) Remove the bind B M4x12, taptite screw, and then remove the LV shield plate.

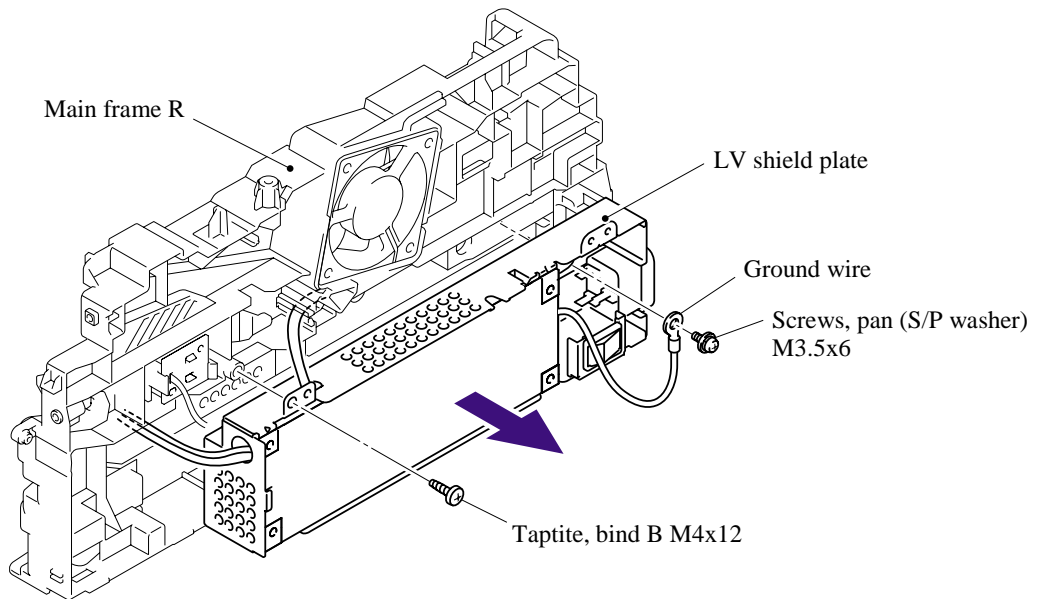

- (10) Remove the two flat S M3x8, taptite screws, and then remove the inlet harness ASSY.

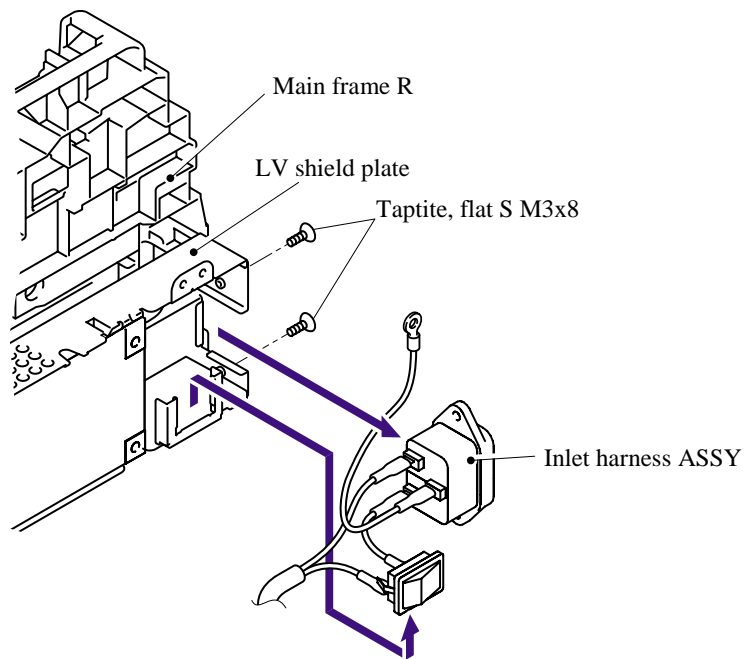

(11) Remove the two cup S M3x6 taptite screws.

(12) Disconnect the three connectors from the PS PCB unit, and then remove the PS PCB unit.

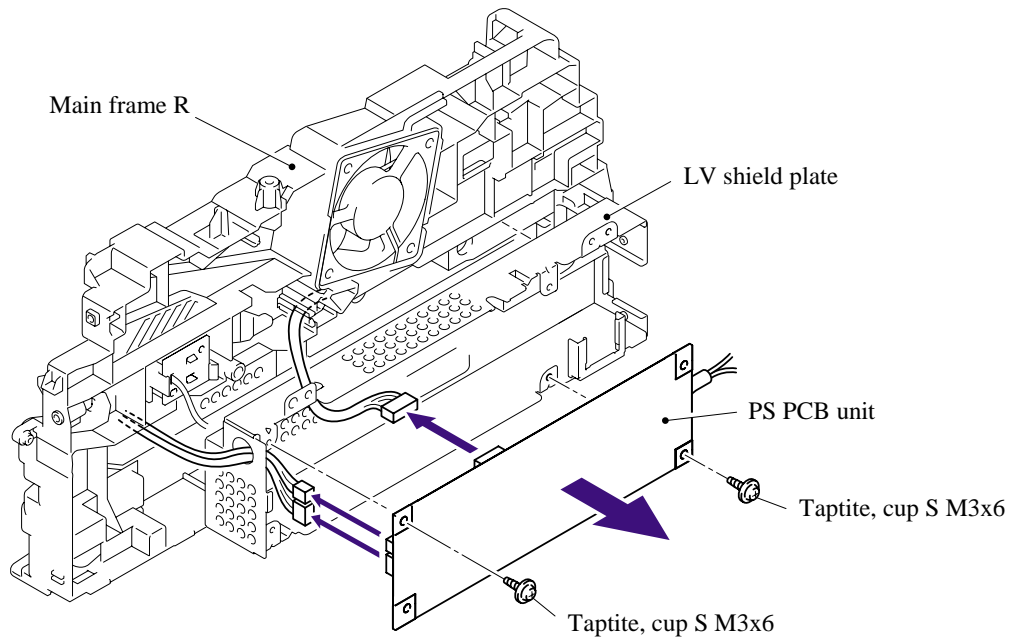

NOTE: When disconnecting the connectors, disconnect the regist sensor PCB connector and toner LED PCB unit ASSY connector first, lift up the PS PCB unit from the LV shield plate, and disconnect the main PCB connector.

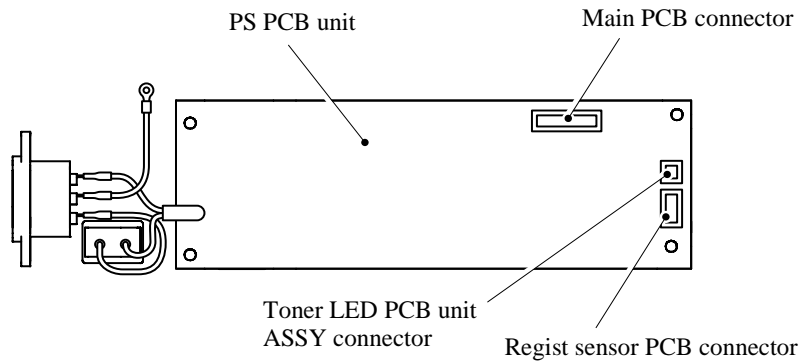

5.1.21 Laser Unit

- (1) Remove the cup S M3x6, taptite screw (A) and FG harness ASSY 6.
- (2) Remove the four cup S M3x6, taptite screws (B).
- (3) Remove the laser unit.

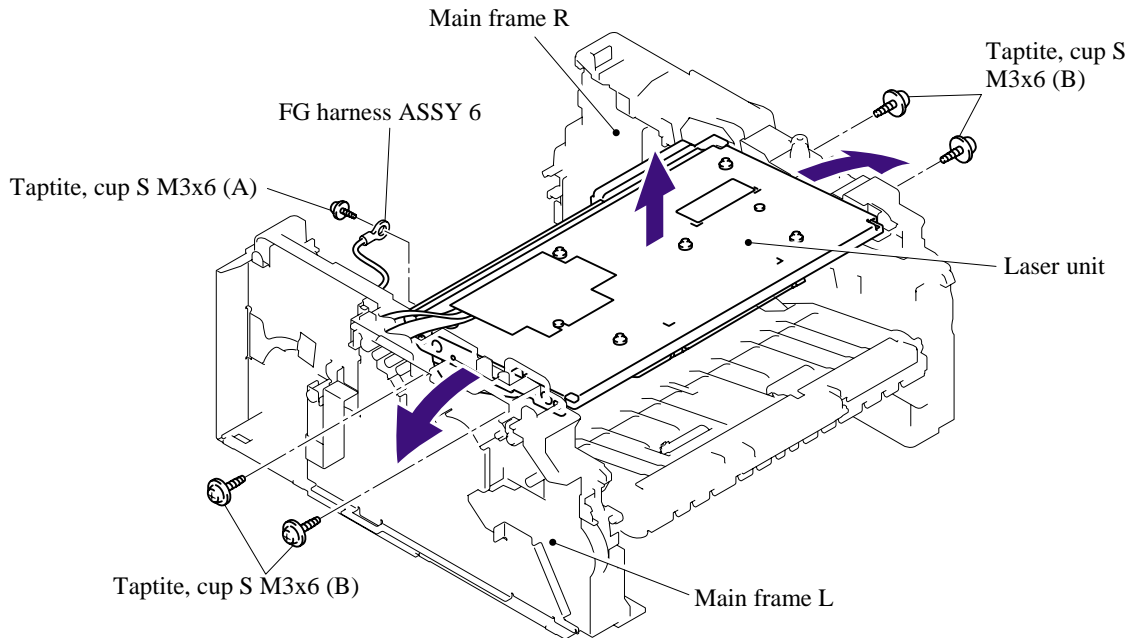

- (4) Remove the filter ASSY from the air duct.
- (5) Remove the two cup S M3x6, taptite screws, and then remove the air duct.

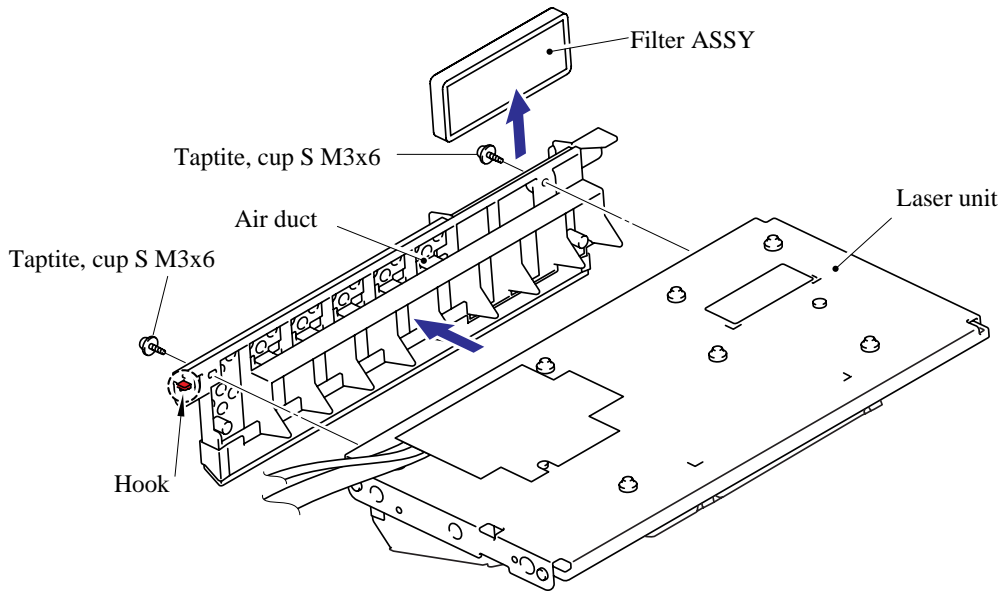

NOTE:

- When replacing the laser unit, replace the barcode label attached on the gear plate calking ASSY with a new one supplied with a new unit.
- Another barcode label supplied with a new unit is spare. Make sure to throw it out.

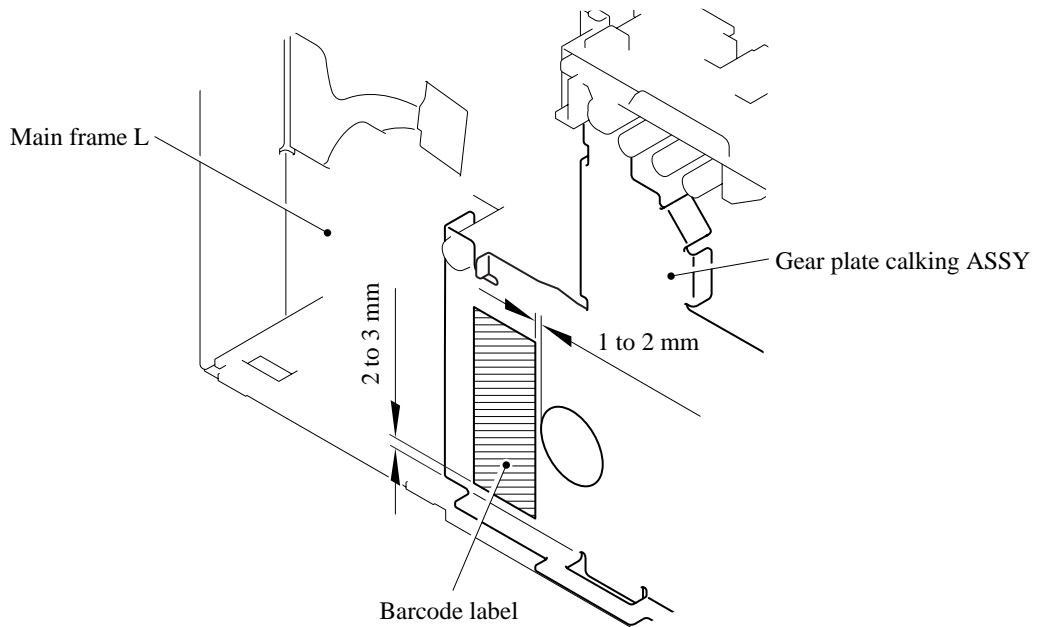

5.1.22 Sub Chute ASSY

- (1) Remove the two bind B M4x12, taptite screws, and then remove the sub chute ASSY.

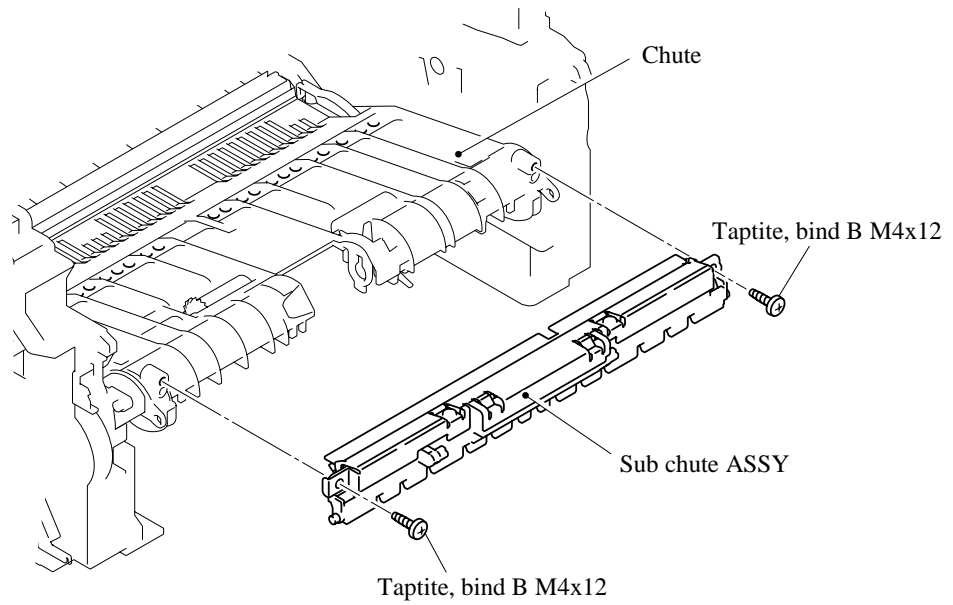

5.1.23 Link Lever

- (1) Turn the printer body upside down.
- (2) Pull the "A" section outwards and remove the link lever.

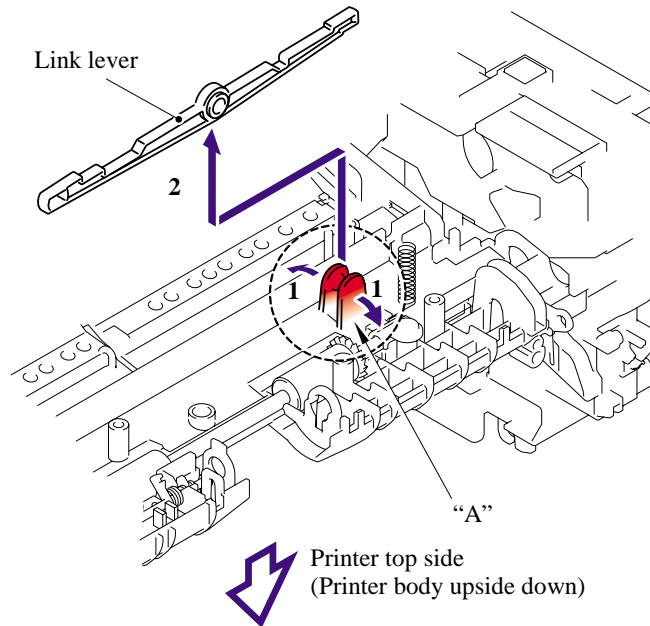

NOTE: When re-assembling the link lever, insert the end of the link lever into the main frame L referring to the figure below.

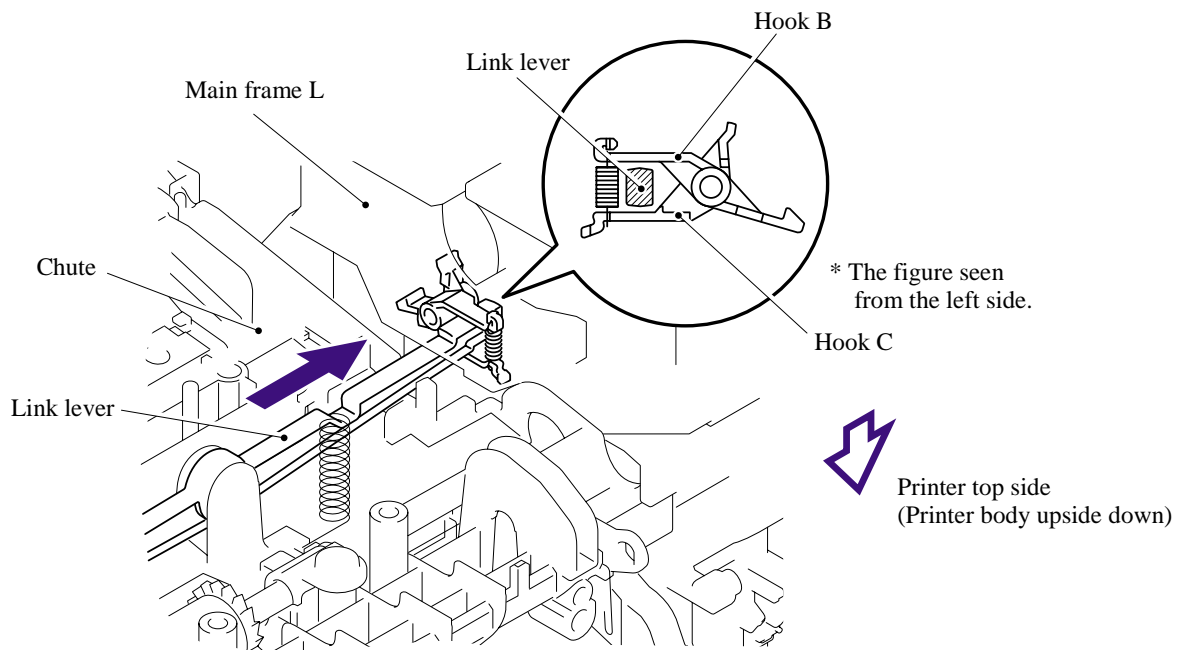

5.1.24 Tail Edge Actuator

- (1) Remove the tail edge actuator with the tail edge spring.
- (2) Remove the tail edge spring from the tail edge actuator.

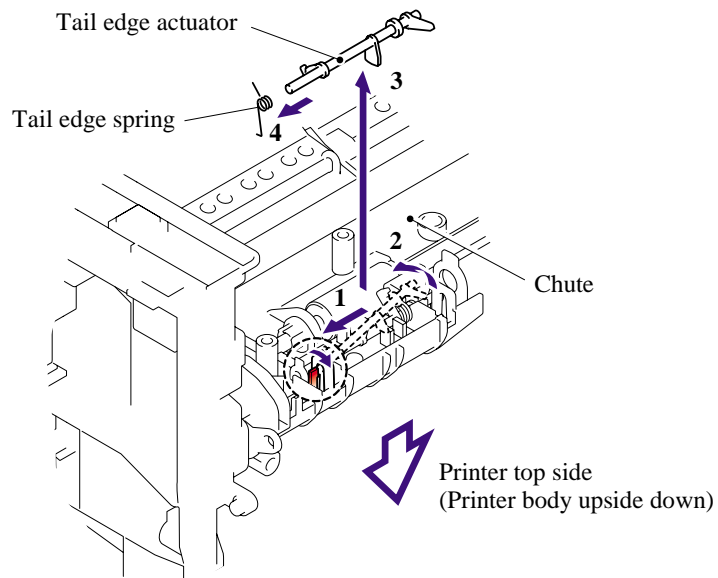

5.1.25 Regist Front Actuator/Regist Front Spring

- (1) Remove the regist front actuator with the regist front spring.
- (2) Remove the regist front spring from the regist front actuator.

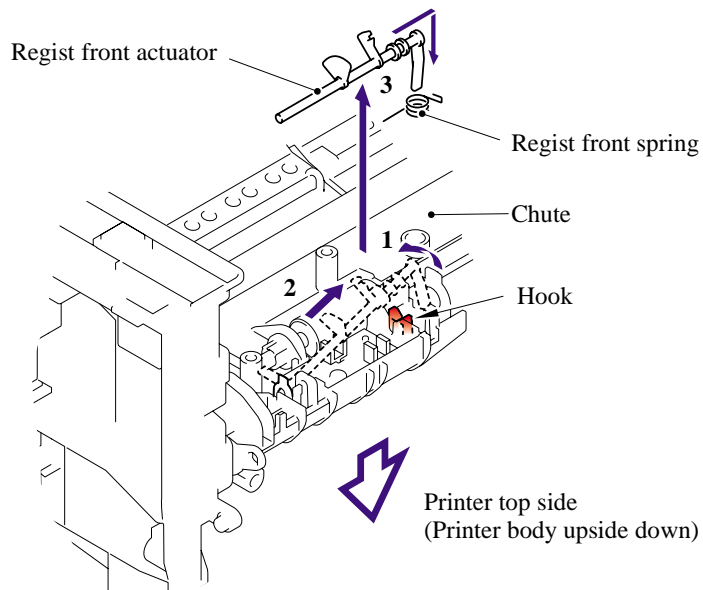

5.1.26 Regist Sensor PCB ASSY

- (1) Remove the bind B M3x6, taptite screw.
- (2) Release the harness from the hook and remove the regist sensor PCB ASSY.

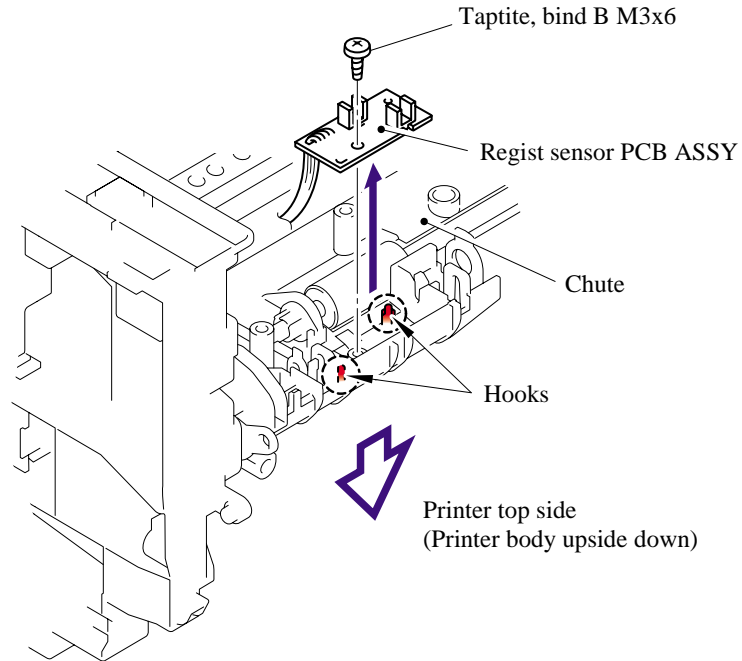

5.1.27 Regist Rear Actuator/Regist Rear Spring

- (1) Remove the regist rear spring.
- (2) Remove the regist rear actuator.

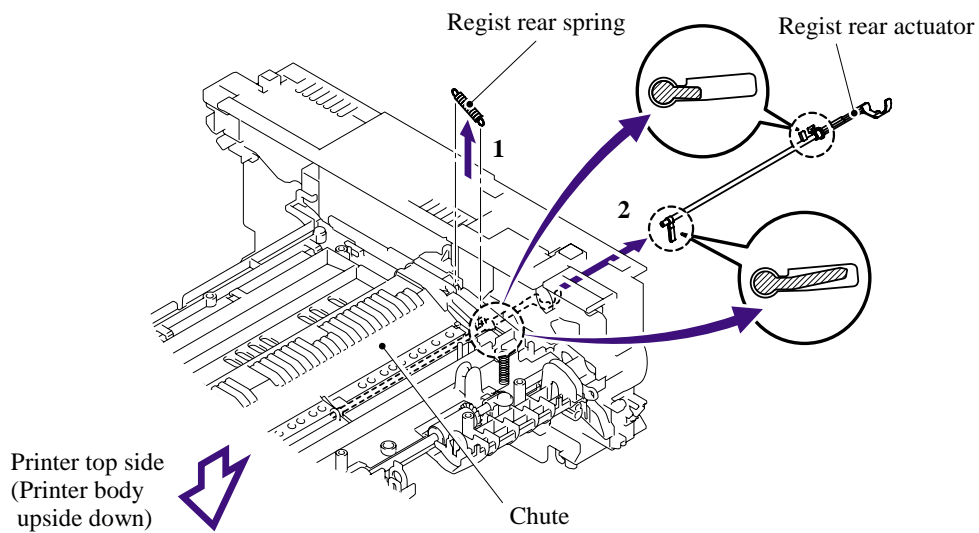

5.1.28 Fan Motor 60 Unit

- (1) Remove the three bind B M4x12, taptite screws and three FG harness ASSY 1, 4, 5.
- (2) Remove the base plate.

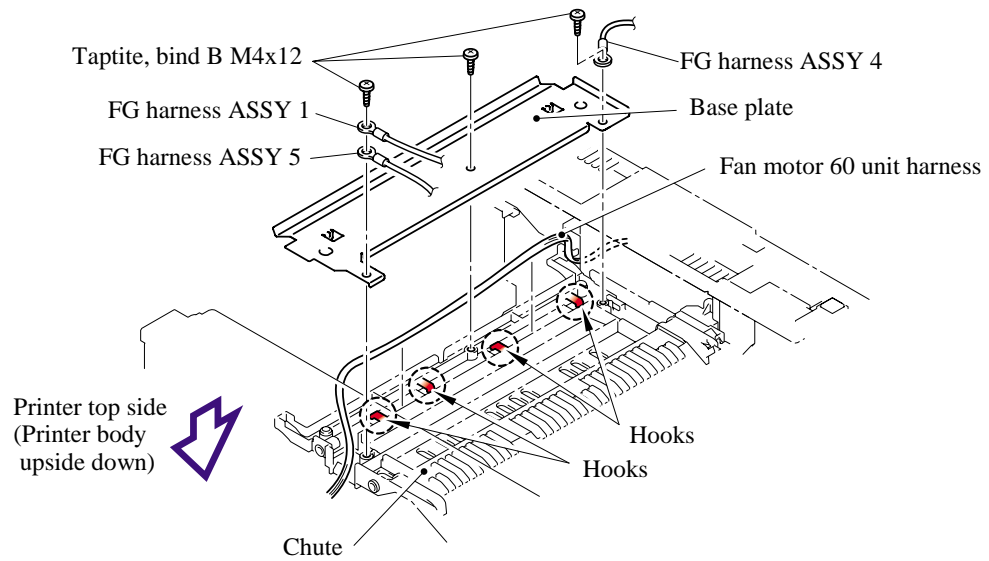

- (3) Release the harness from the hook, and then remove the fan motor 60 unit from the main frame R.

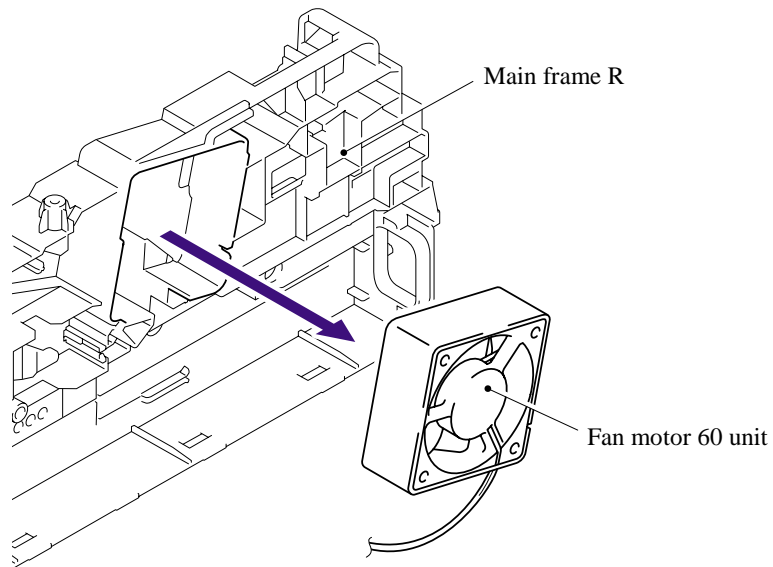

5.1.29 Toner LED PCB ASSY/LED Holder

- (1) Remove the toner LED PCB ASSY from the main frame R.

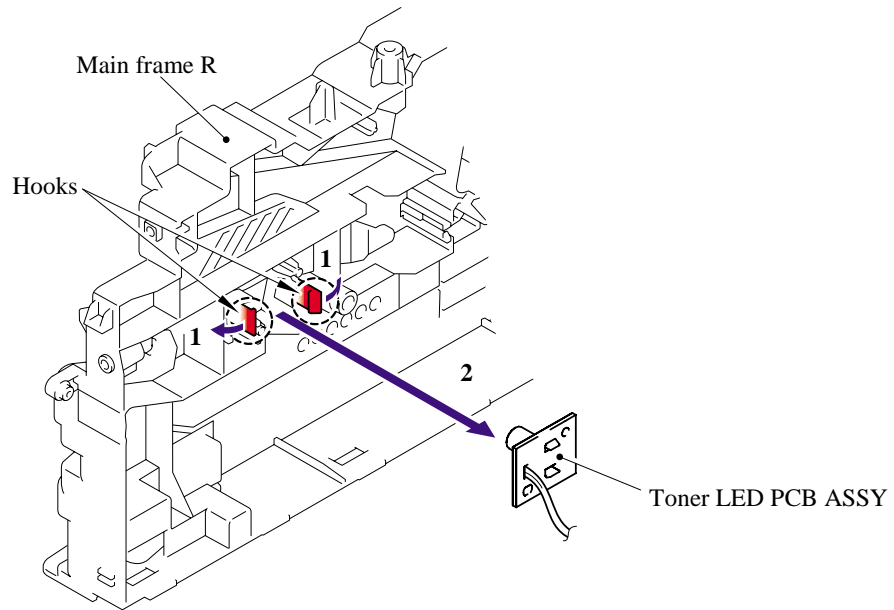

- (2) Remove the LED holder from the toner LED PCB ASSY.

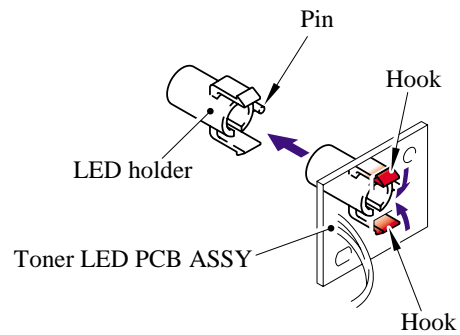

5.1.30 New Toner Actuator/New Toner Actuator Spring

- (1) Remove the new toner actuator spring.
- (2) Release the hook and remove the new toner actuator from the main frame L.

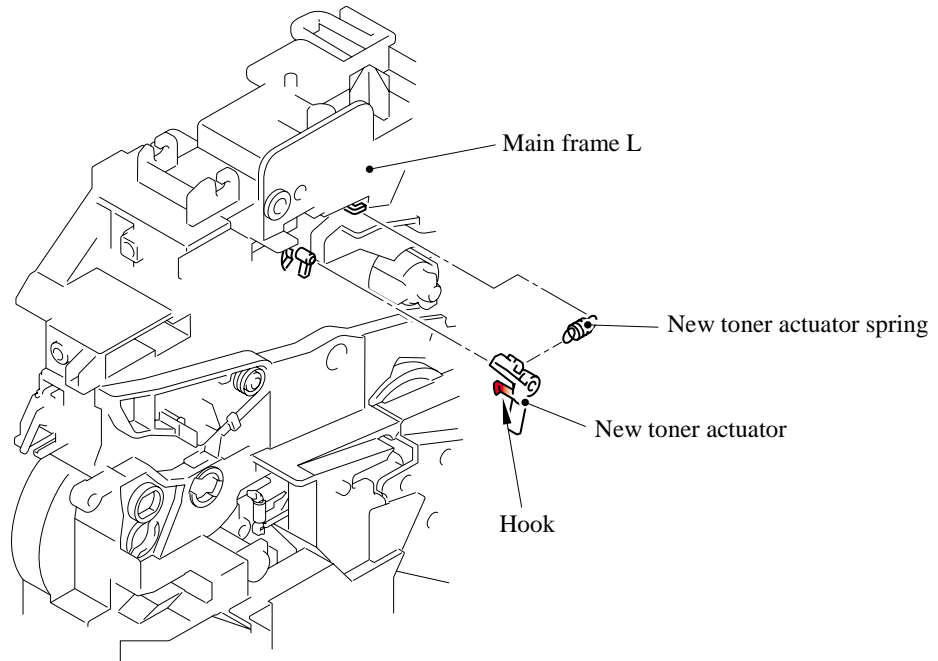

5.1.31 New Toner Sensor

- (1) Release the two hooks and remove the new toner sensor from the main frame L.

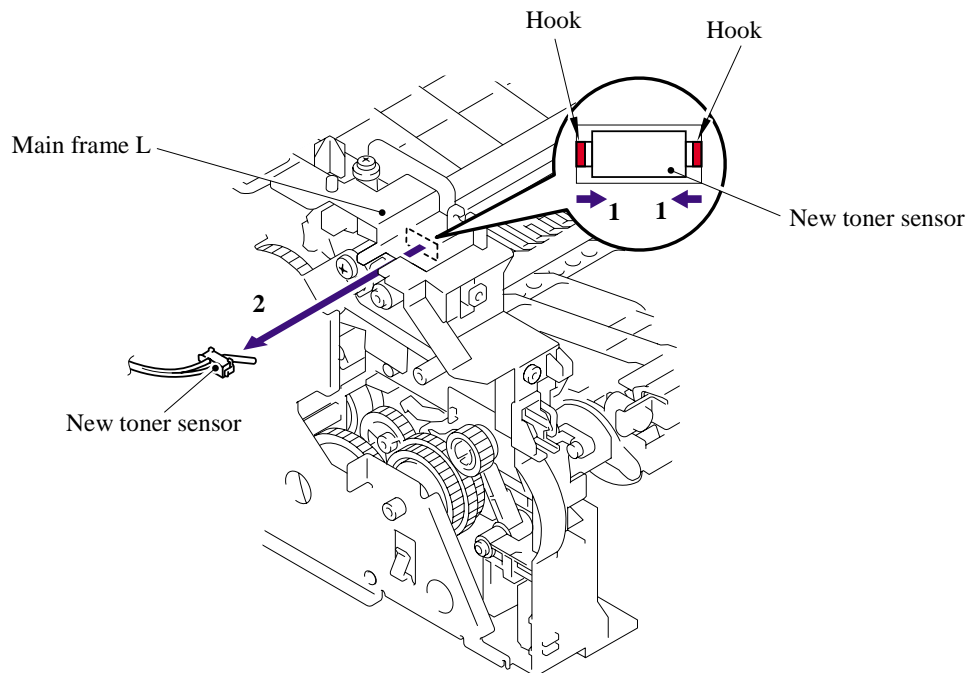

5.1.32 Cover Sensor

- (1) Release the two hooks and remove the cover sensor from the main frame L.

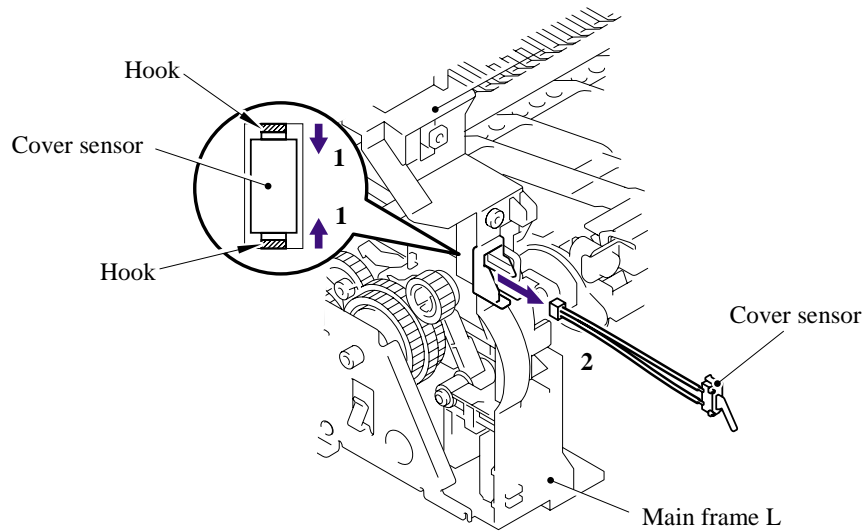

5.1.33 Toner Sensor PCB ASSY

- (1) Remove the cup B M3x6, taptite screw, and then remove the toner sensor PCB ASSY.

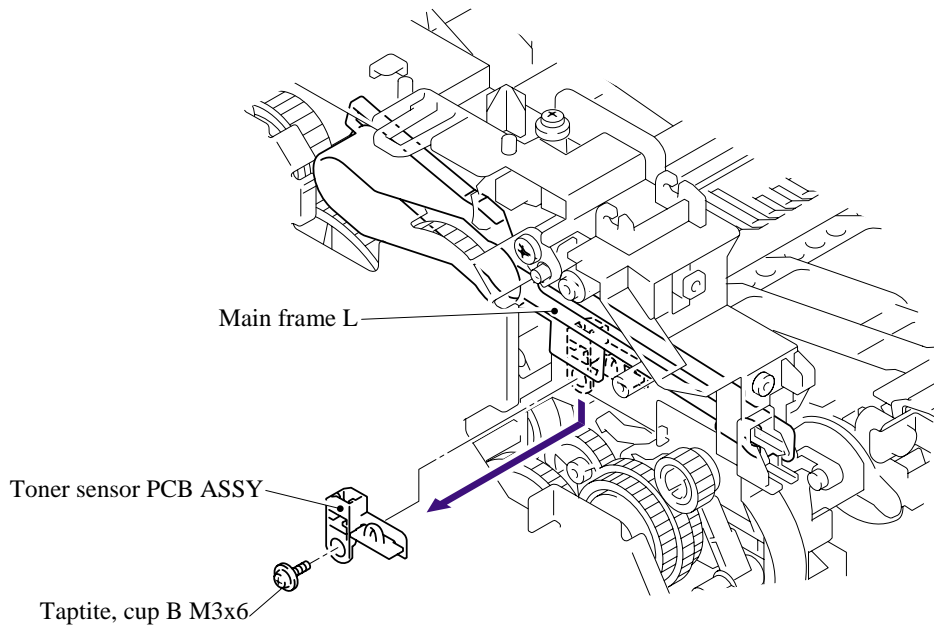

5.1.34 Main Motor ASSY

- (1) Remove the HVPS insulation sheet.
- (2) Remove the five bind B M4x12, taptite screws, and then remove the gear plate calking ASSY.

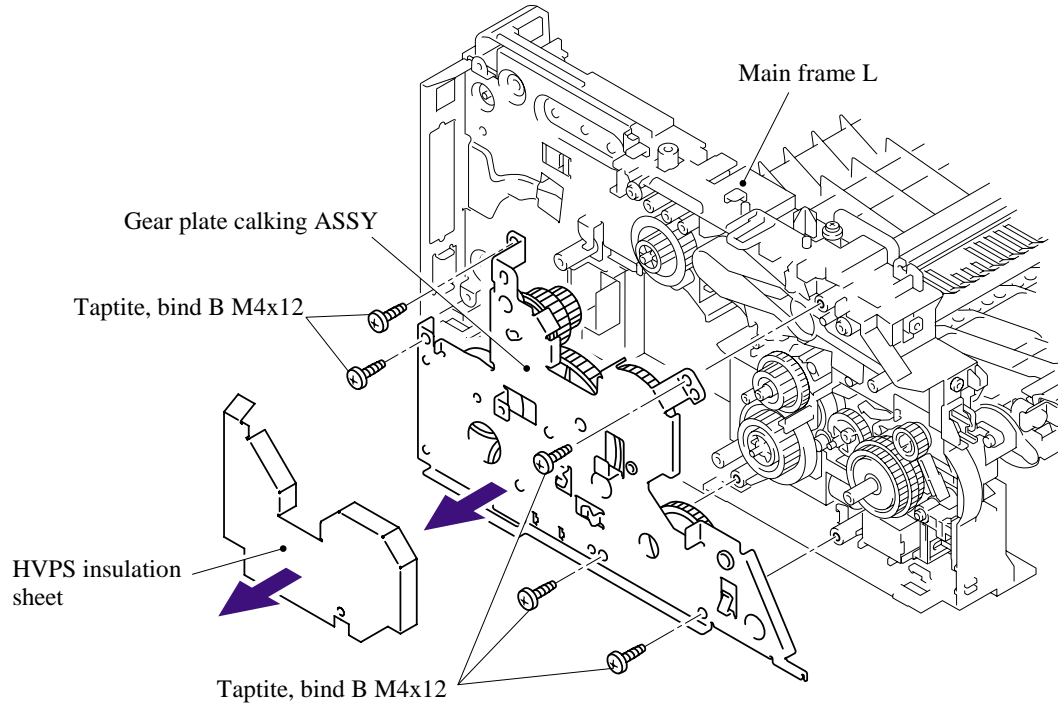

- (3) Remove the three cup S M3x6, taptite screws, and then remove the main motor ASSY.

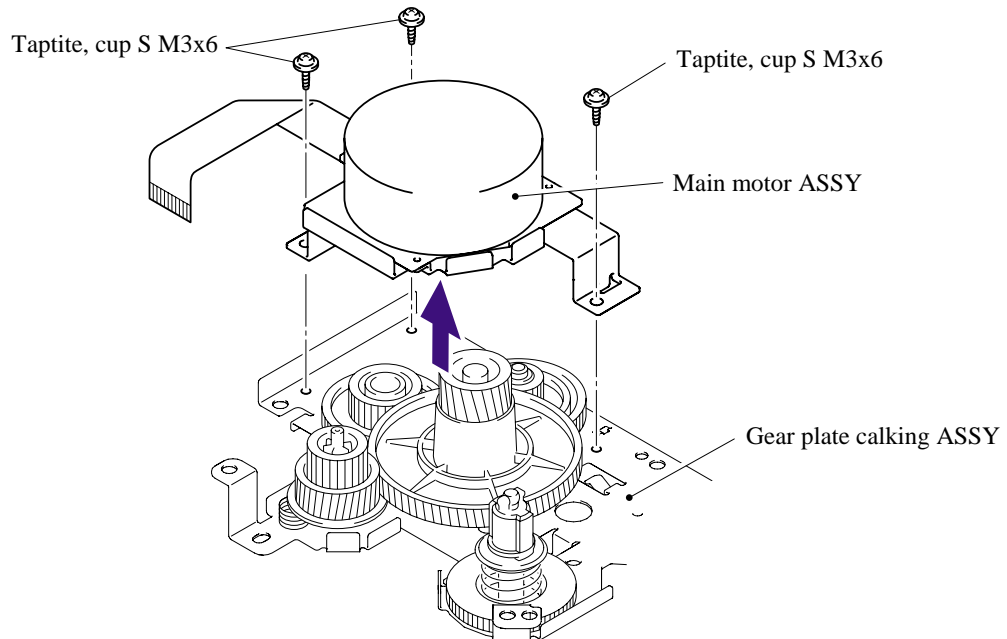

5.1.35 Develop Joint

- (1) Remove the develop joint from the gear plate calking ASSY.

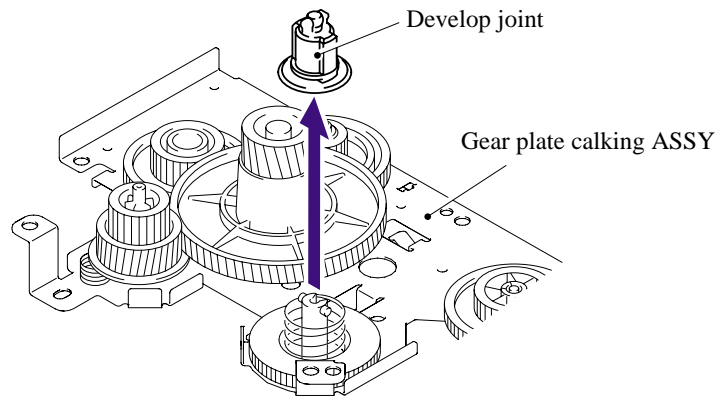

5.1.36 P/R Solenoid ASSY

- (1) Remove the bind B M3x10, taptite screw.
- (2) Remove the P/R solenoid ASSY, the P/R solenoid lever and the solenoid release spring P/R.

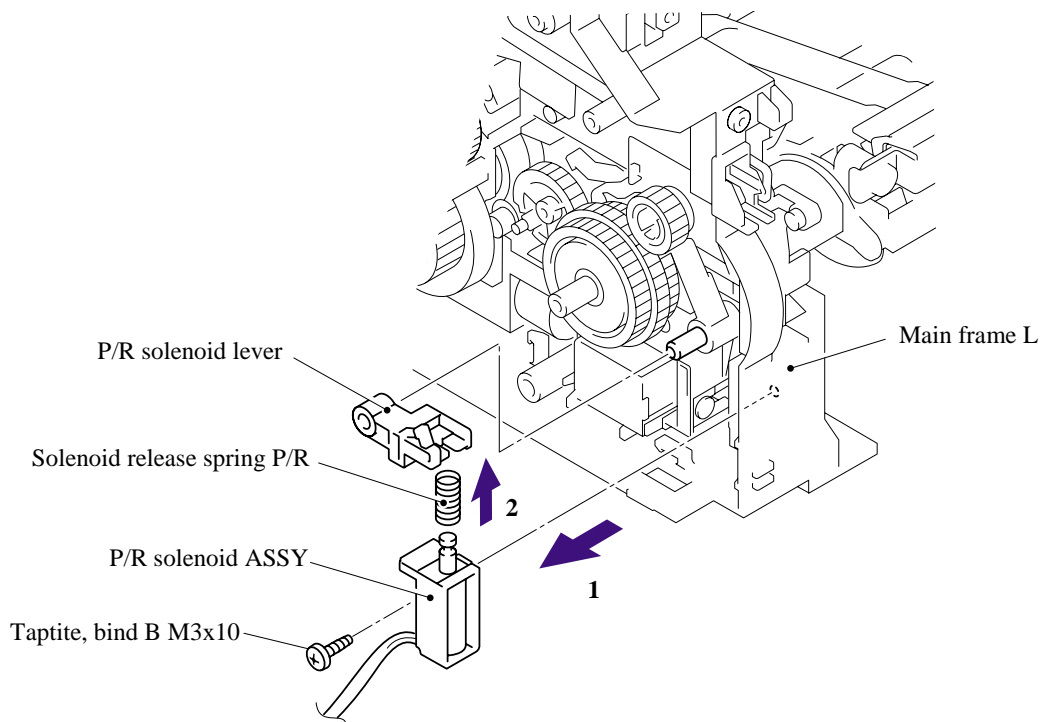

5.1.37 F/R Solenoid ASSY

- (1) Remove the gear ASSY from the main frame L.

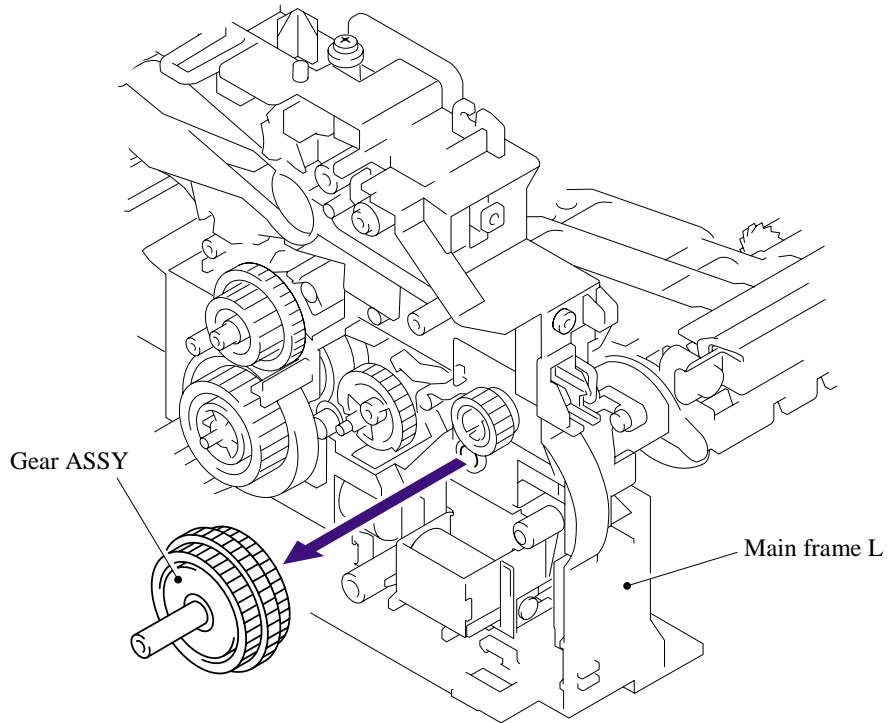

NOTE: The gear ASSY contains the small gears. Be careful not to lose them by disassembling the gear ASSY.

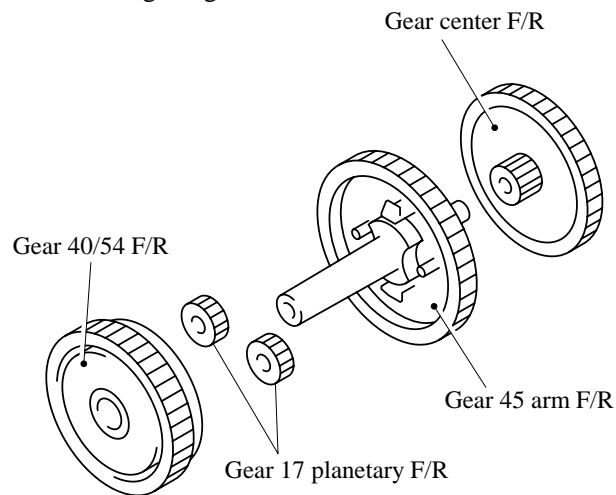

- (2) Remove the bind B M3x10, taptite screw.
- (3) Remove the F/R solenoid ASSY, the F/R solenoid lever and the solenoid release spring F/R.

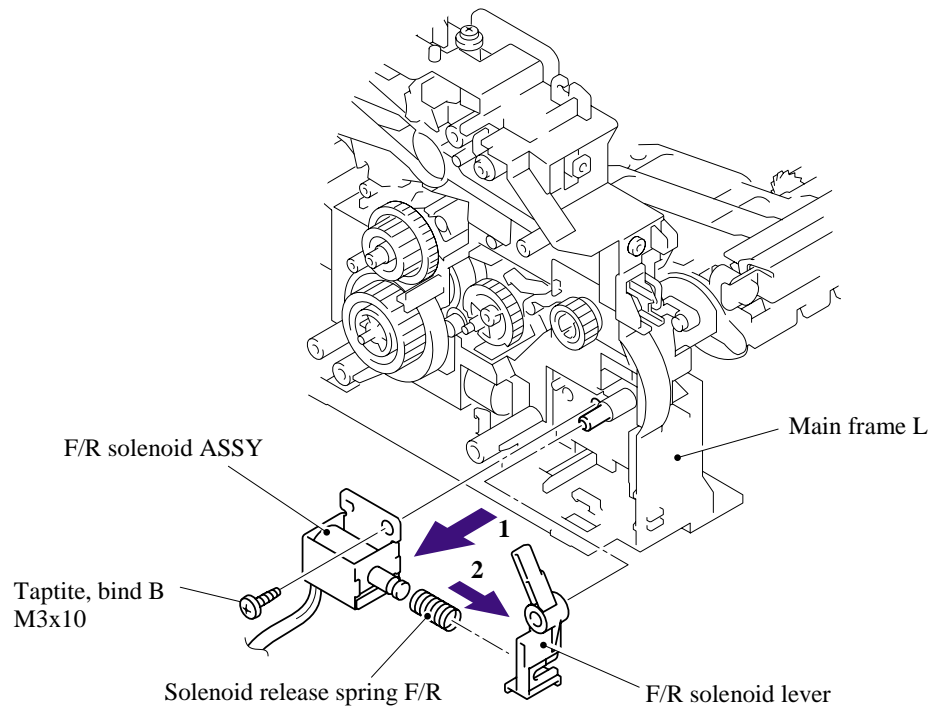

5.1.38 Main Frame L

- (1) Remove the two bind B M4x12, taptite screws, and then remove the main frame L.

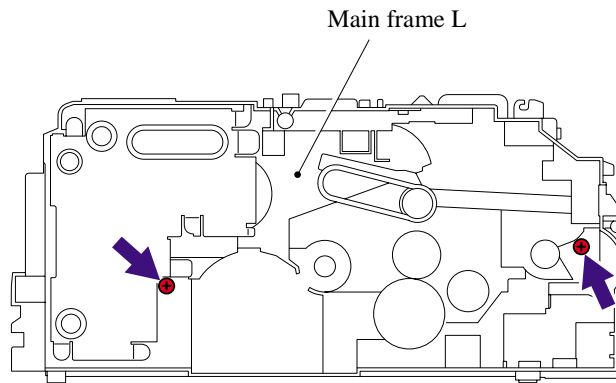
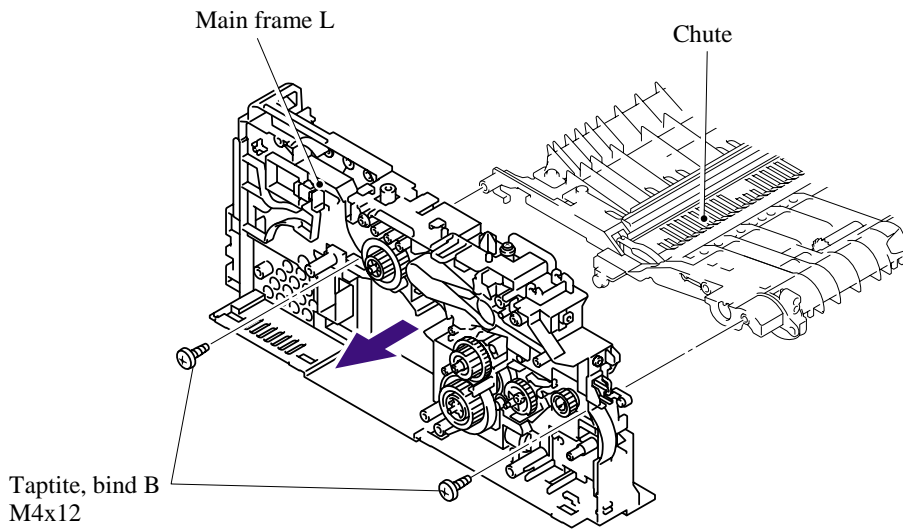

5.1.39 Main Frame R

- (1) Remove the three bind B M4x12, taptite screws, and then remove the main frame R.

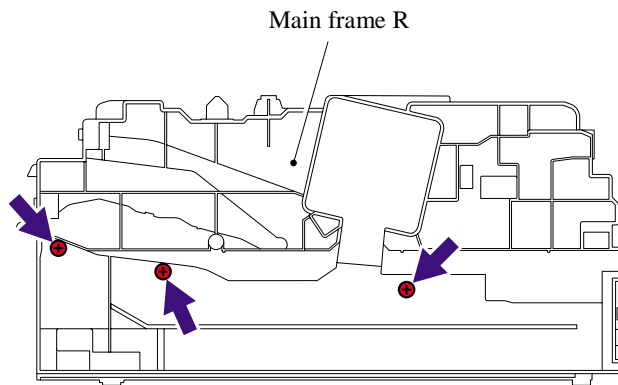
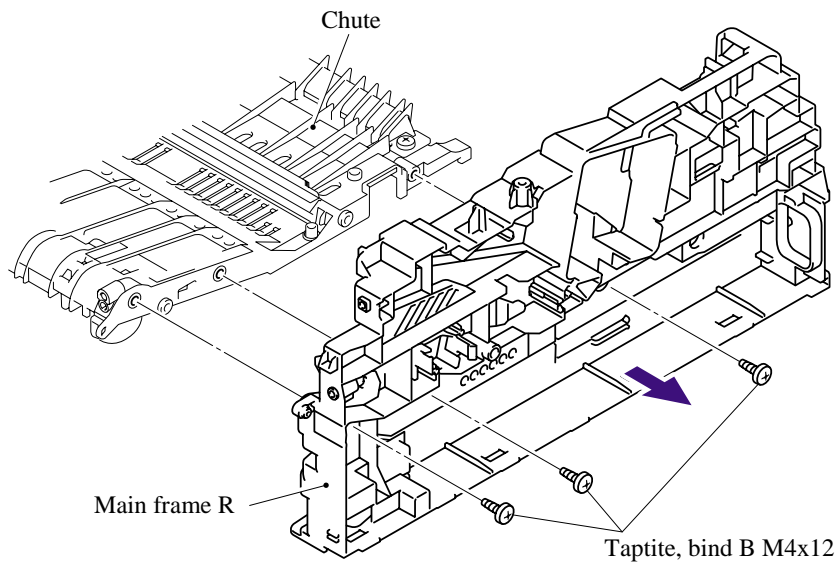

5.1.40 Harness Routing

1

· Laser unit

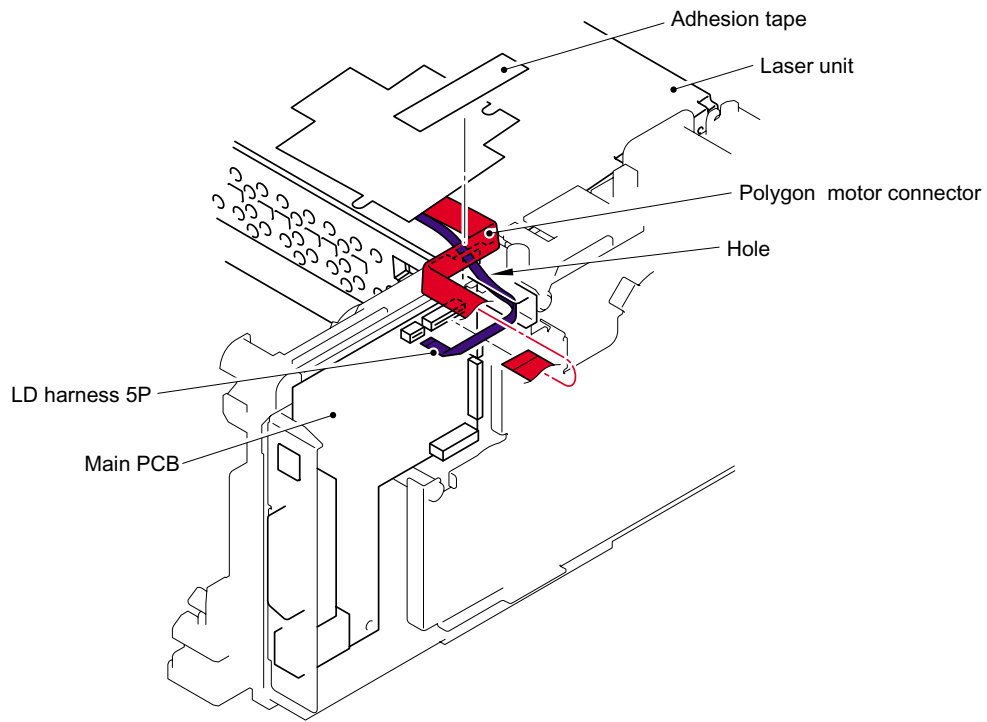

2

· FG harness ASSY 1 / FG harness ASSY 5

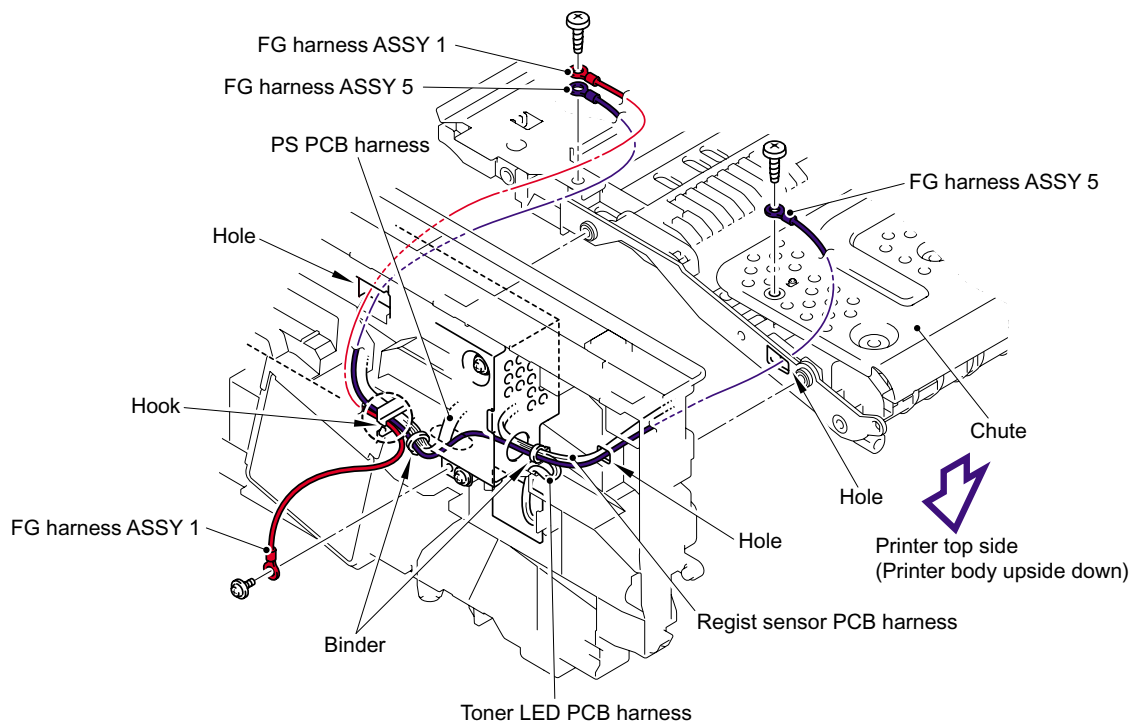

3

· FG harness ASSY 6

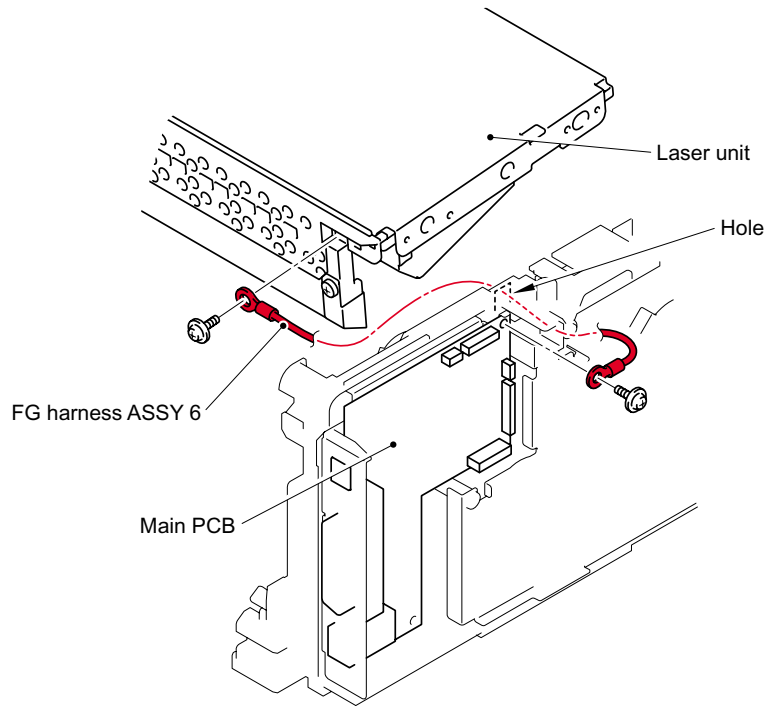

4

· Regist sensor PCB ASSY

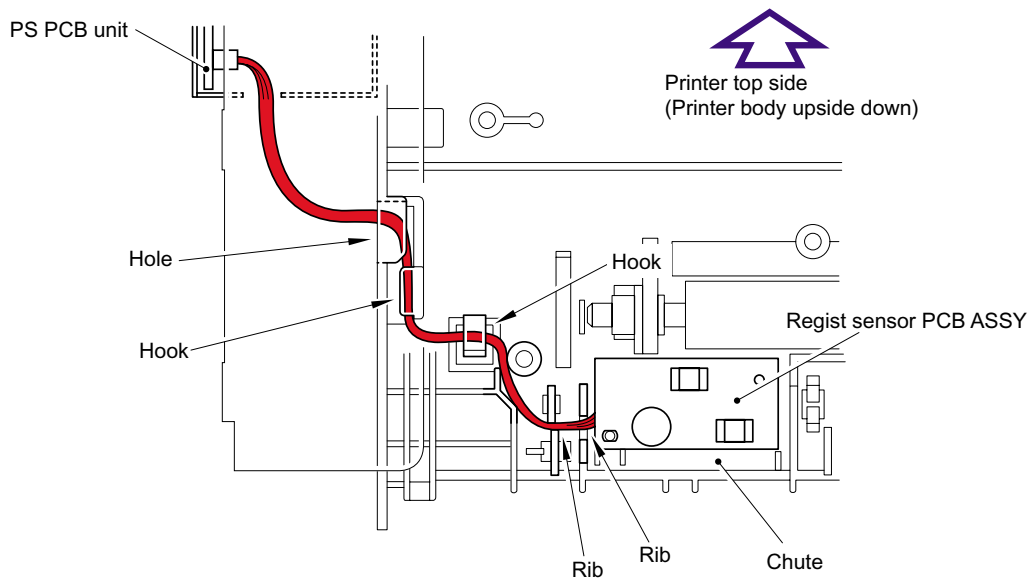

5 · Fan motor 60 unit

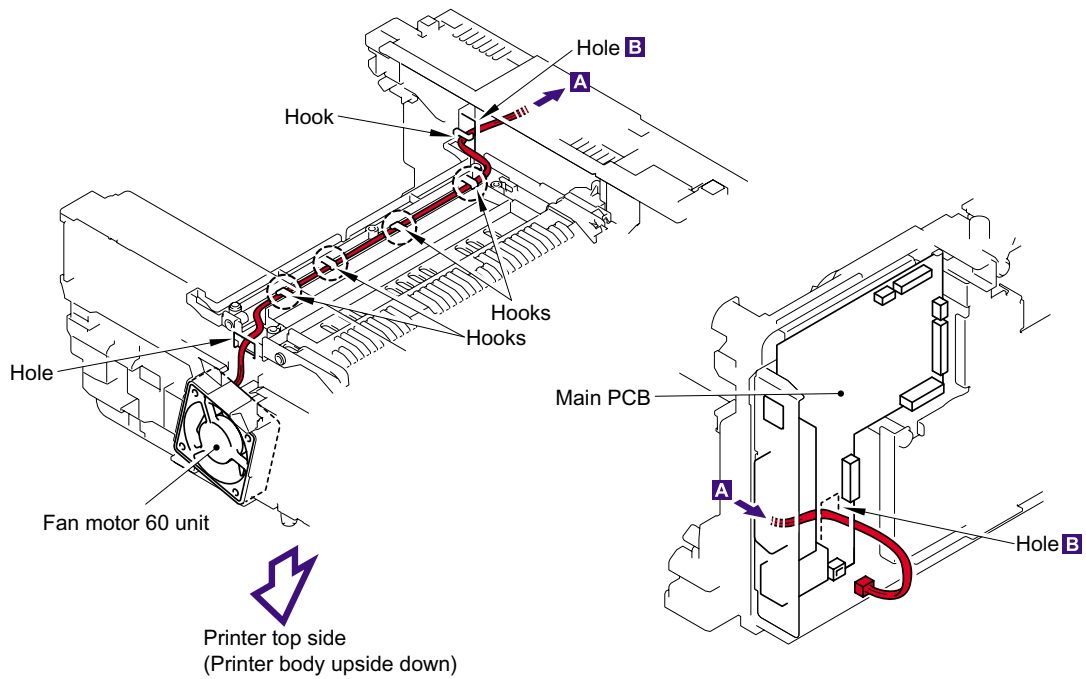

6 · Toner LED PCB ASSY

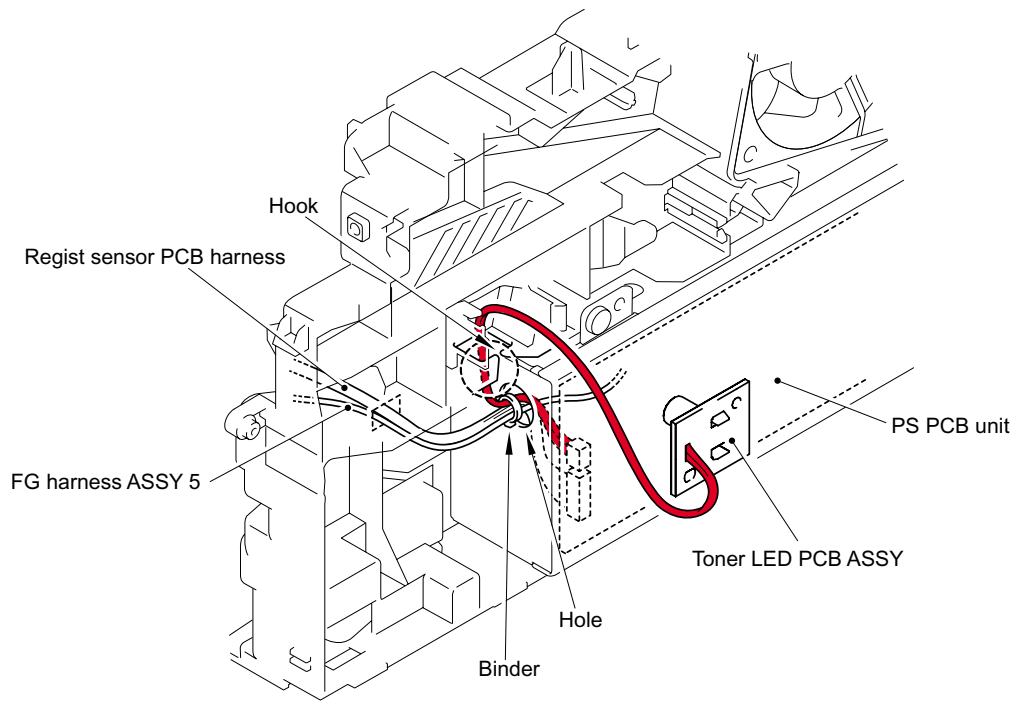

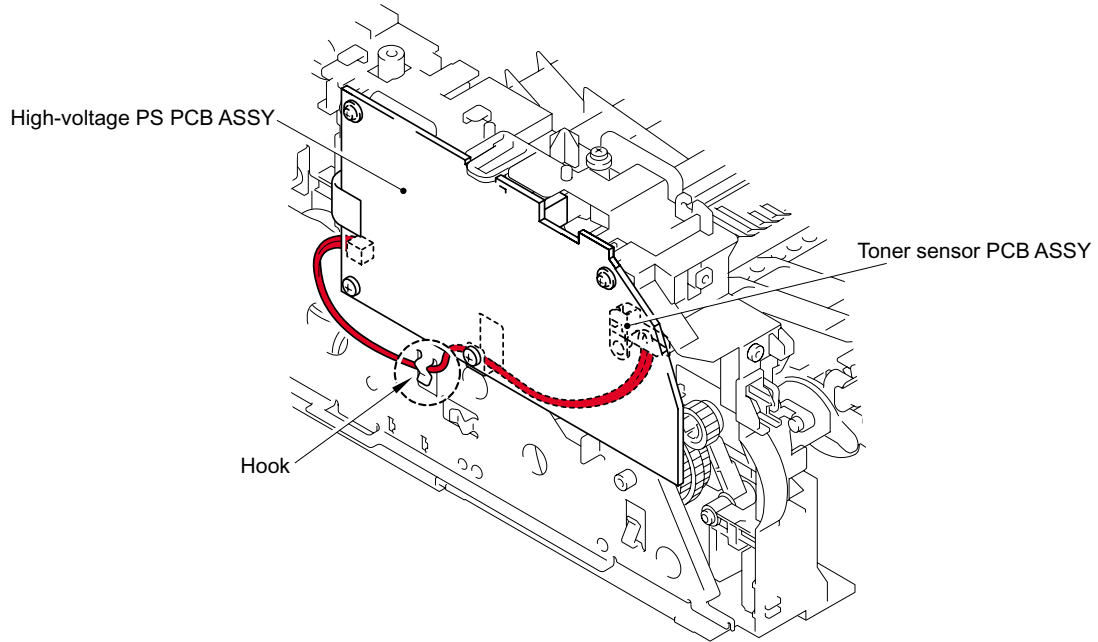
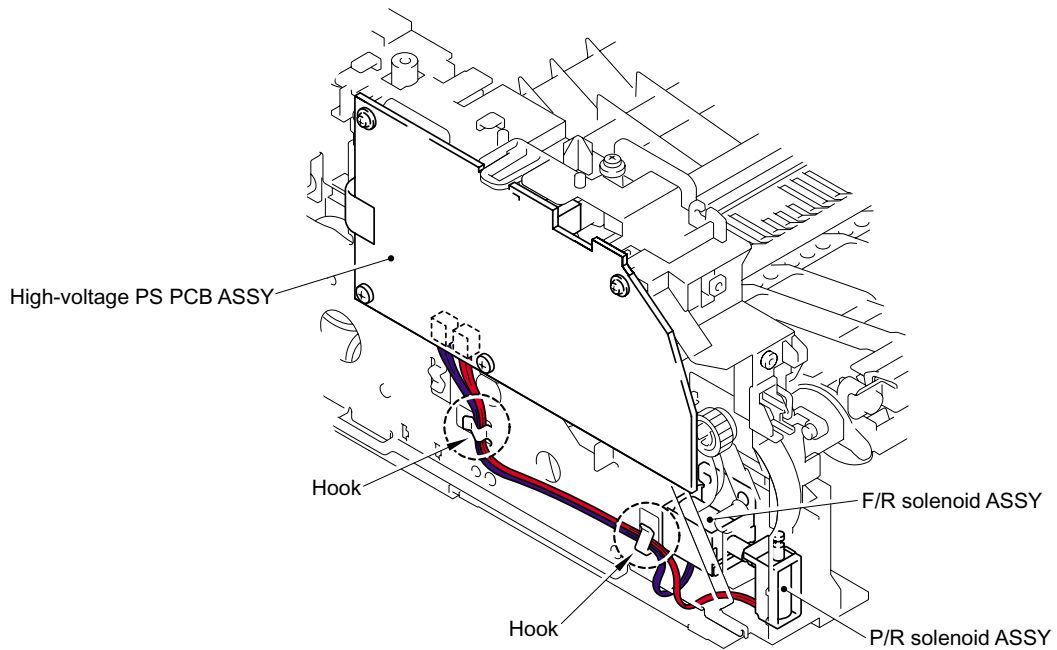
7**· Toner sensor PCB ASSY****8****· P/R solenoid ASSY / F/R solenoid ASSY**

9

· New toner sensor / Cover sensor / Battery harness

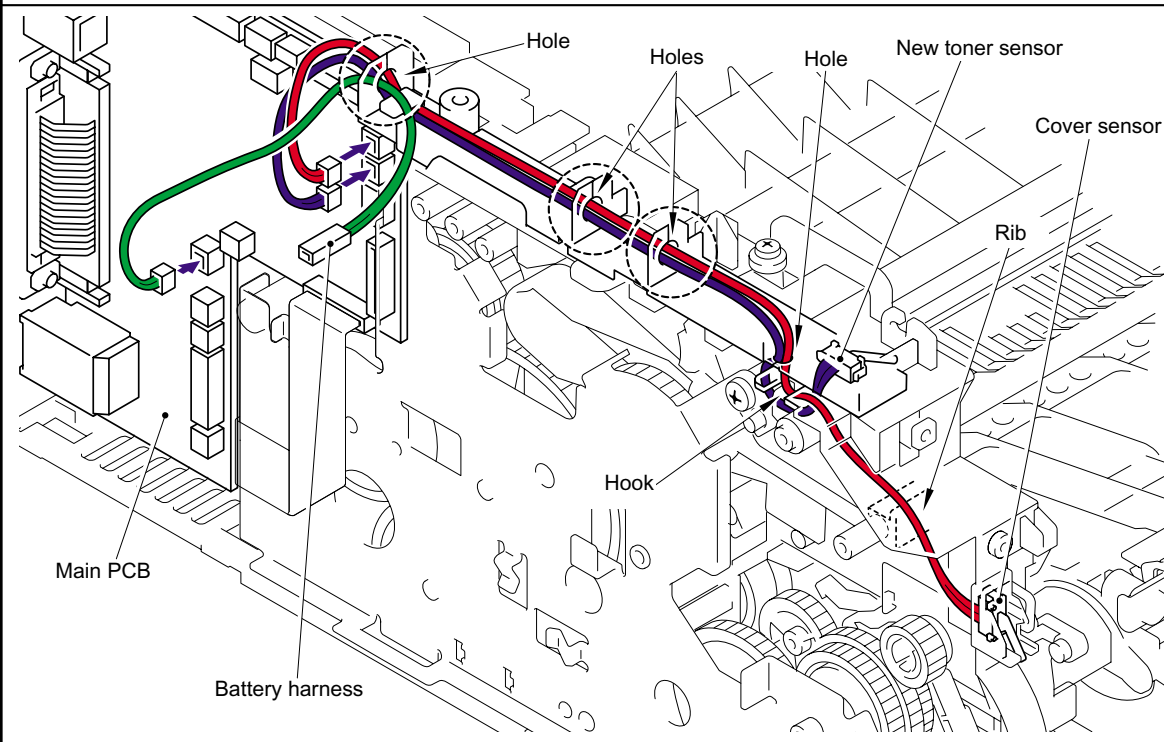

10

· Panel unit

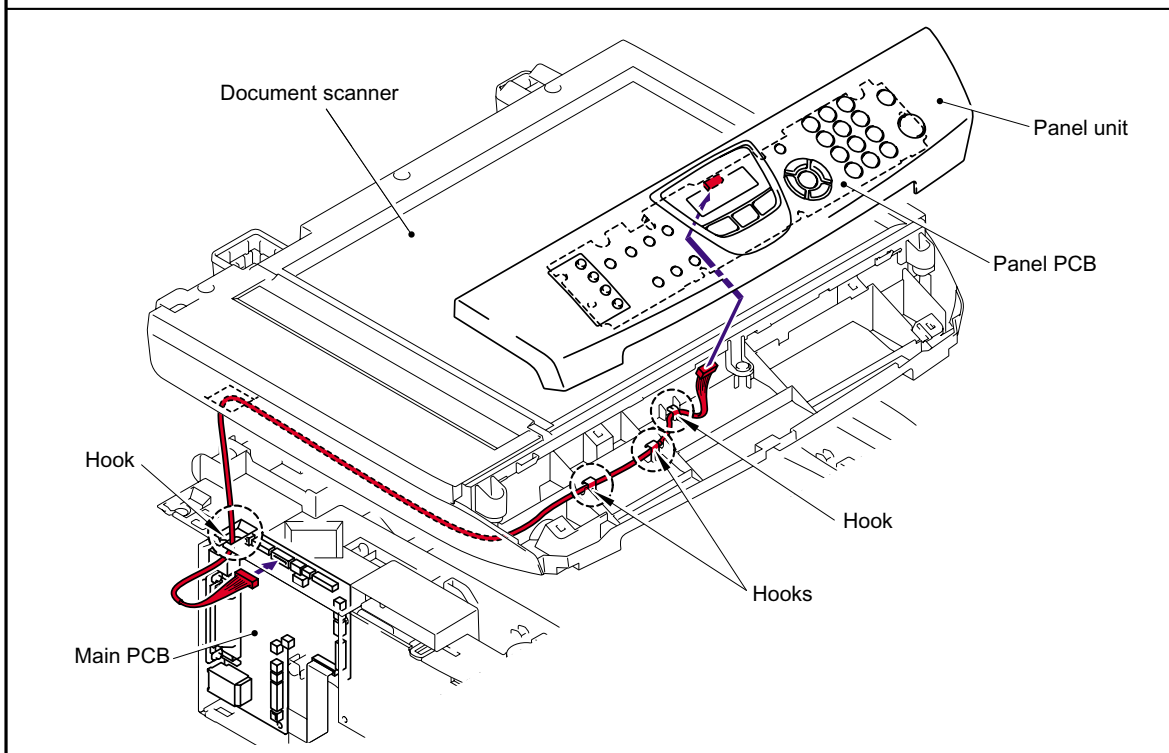

11

· ADF unit

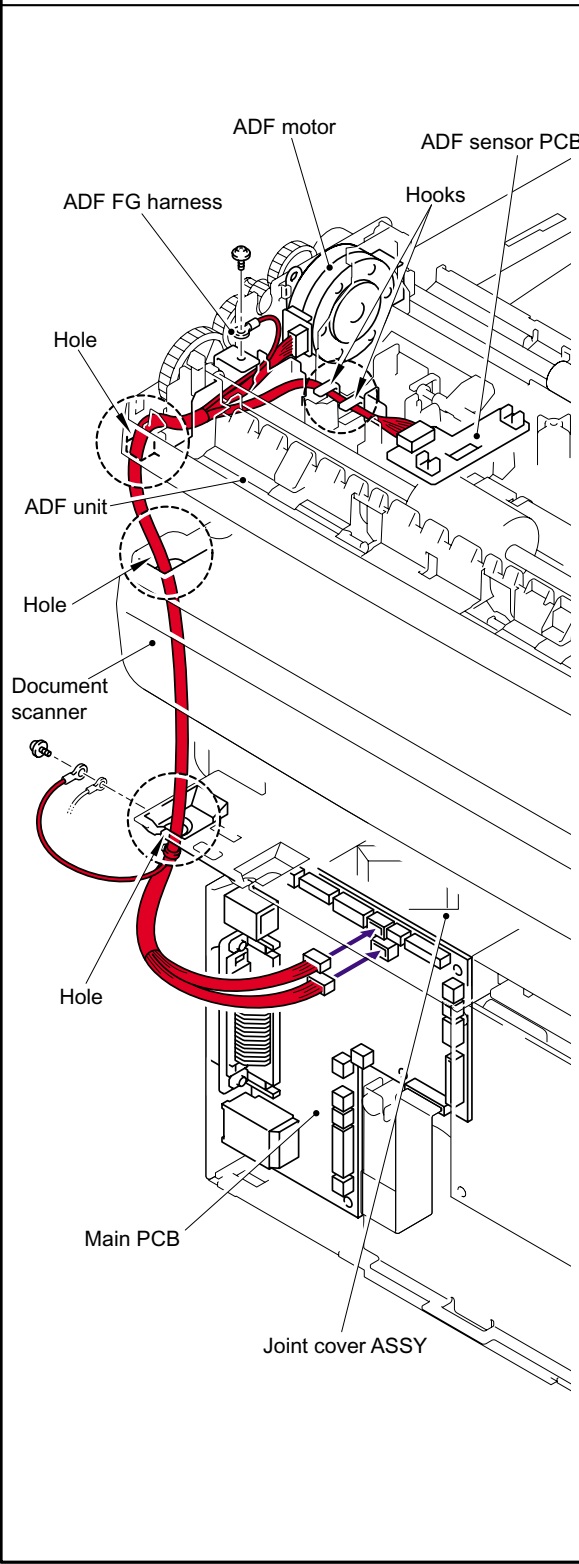

12

· Document scanner

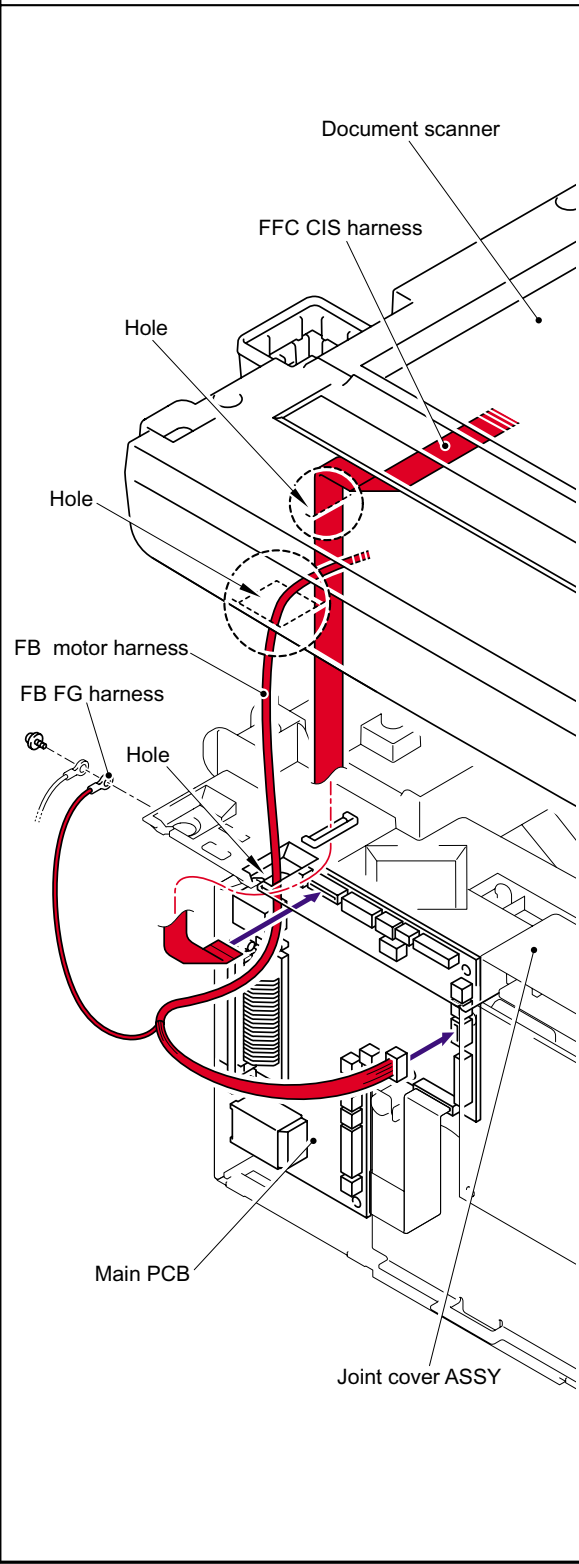

13 · NCU PCB

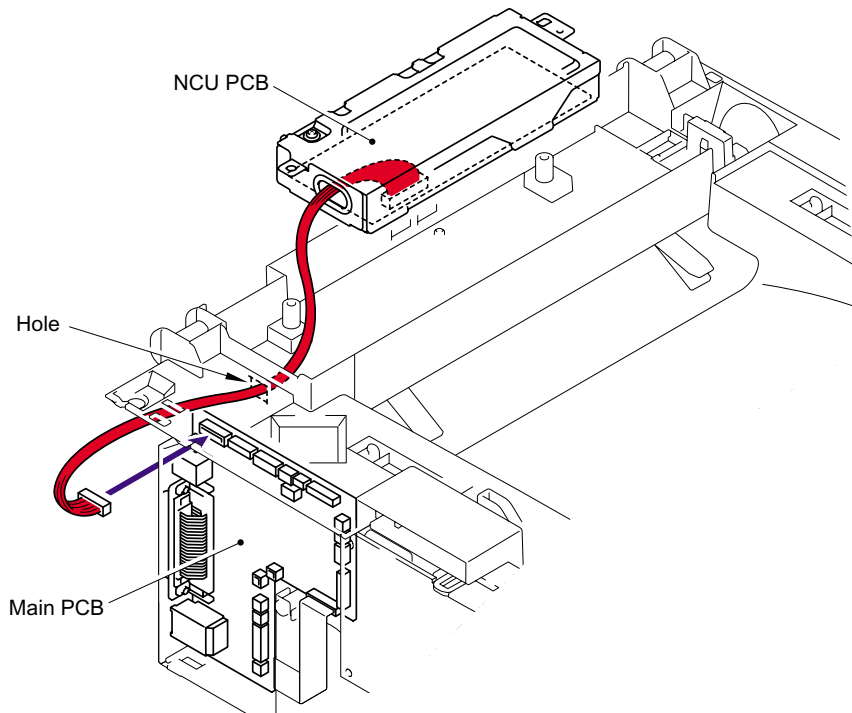

14 · NCU FG harness

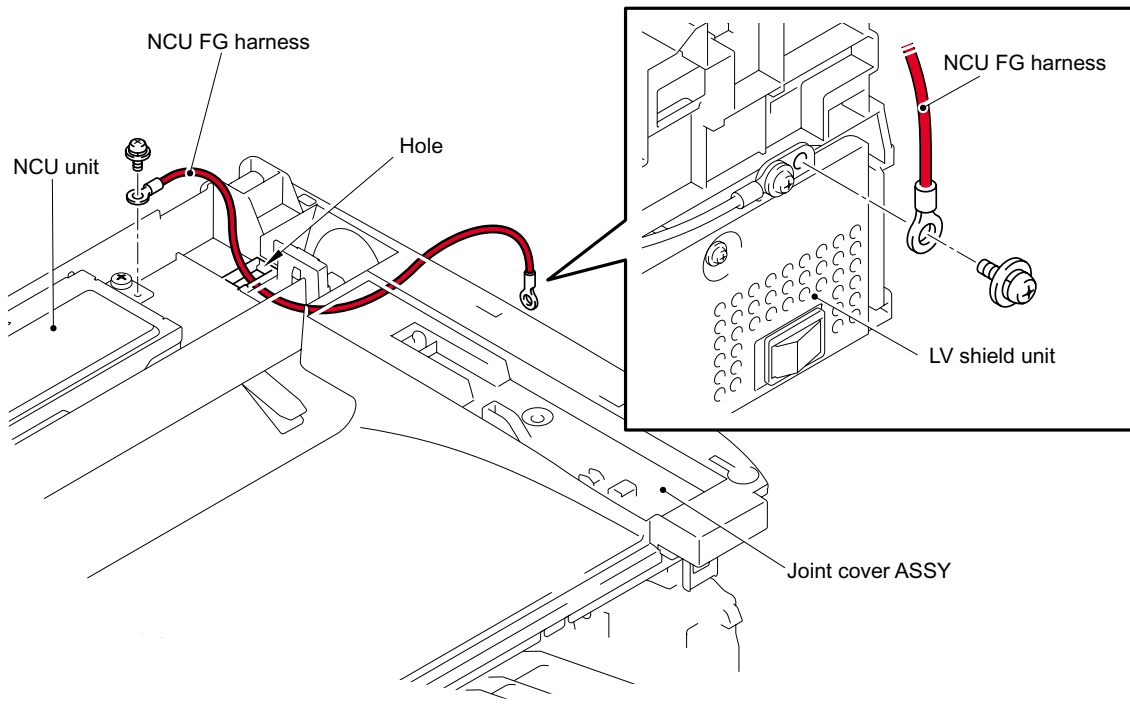

15

· Speaker ASSY

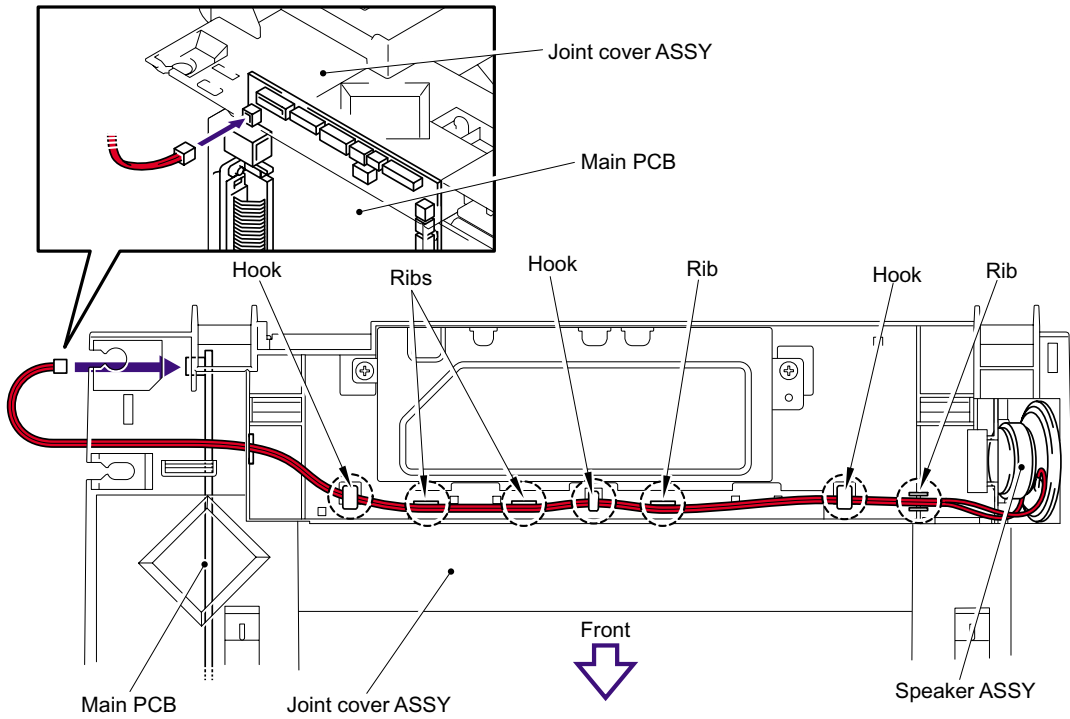

5.2 LUBRICATION

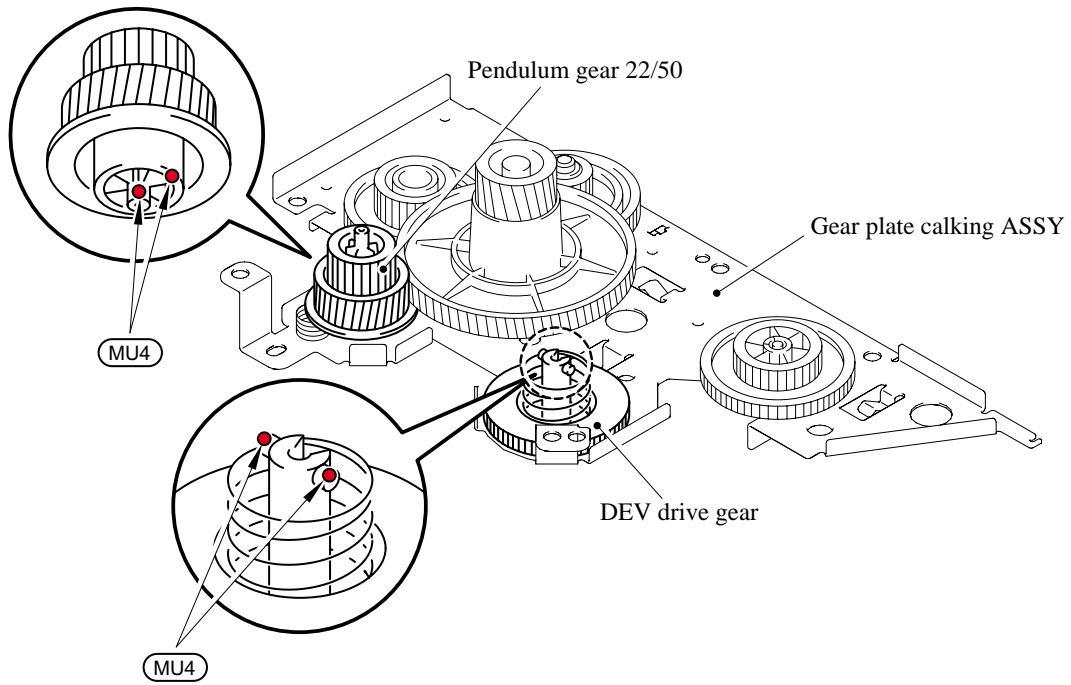

* BG4: KANTO KASEI BG- MU (4 mm dia. Ball)

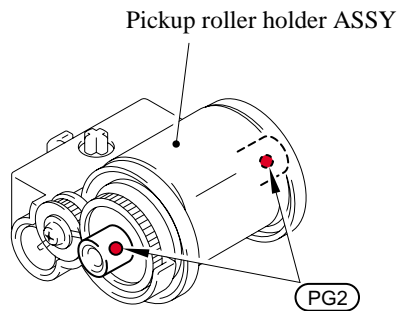

* PG2: PG- 661 (2 mm dia. Ball)

CHAPTER 6

ADJUSTMENTS AND UPDATING OF SETTINGS, REQUIRED AFTER PARTS REPLACEMENT

Confidential

CHAPTER 6 ADJUSTMENTS AND UPDATING OF SETTINGS, REQUIRED AFTER PARTS REPLACEMENT

This chapter details adjustments and updating of settings, which are required if main PCB and some other parts have been replaced.

CONTENTS

6.1 IF YOU REPLACE THE MAIN PCB	6-1
[1] Load update programs/data	6-1
[2] Initialize the EEPROM on the main PCB (Function code 01)	6-1
[3] Customize the EEPROM on the main PCB (Function code 74)	6-1
[4] Check the control panel PCB for normal operation (Function code 13)	6-1
[5] Make a sensor operation check (Function code 32)	6-1
[6] Acquire of white level data and set the CIS scanner area (Function code 55).....	6-1
[7] Setting the serial number.....	6-1
[8] Inputting the adjusted value of the laser scanner.....	6-1
[9] Switch back to standby.....	6-1
6.2 IF YOU REPLACE THE LASER SCANNER UNIT ASSY	6-2
[1] Inputting the adjusted value of the laser scanner	6-2
6.3 IF YOU REPLACE THE DOCUMENT SCANNER UNIT	6-2
[1] Acquire of white level data and CIS scanner area setting (Function code 55).....	6-2

Confidential

6.1 IF YOU REPLACE THE MAIN PCB

[1] Load update programs/data

If the main PCB is replaced with a new one, write the update programs/data onto the flash ROM.

Refer to [Appendix 2, page App. 2-2](#).

[2] Initialize the EEPROM on the main PCB (Function code 01)

Refer to [Chapter 8, Section 8.4.1](#).

[3] Customize the EEPROM on the main PCB (Function code 74)

Refer to [Chapter 8, Section 8.4.14](#).

[4] Check the control panel PCB for normal operation (Function code 13)

Refer to [Chapter 8, Section 8.4.8](#).

[5] Make a sensor operation check (Function code 32)

Refer to [Chapter 8, Section 8.4.9](#).

[6] Acquire of white level data and set the CIS scanner area (Function code 55)

Refer to [Chapter 8, Section 8.4.12](#).

[7] Setting the serial number

- (1) Double-click the brmainte.EXE file (maintenance utility).
- (2) Select Input Information from Menu. Select the applicable model name.
- (3) Check the port (USB) which the printer is connected through and click “Serial No.” in the lower box. Enter the serial number (the last nine digits) of the printer into the box at the right hand side and click the **OK** button. The serial number is shown in the window, and check that it is correct. The setting of the serial number is completed.

[8] Inputting the adjusted value of the laser scanner

Select ‘Adjust Scanner’ from Menu. Enter the figures (the last four digits) shown on the label attached on the chassis at the right hand side of the main PCB into the box at the right hand side, and click the **OK** button.

[9] Switch back to standby

MFC 7420 / 7820N

Unplug the USB cable and press the **9** key twice.

DCP 7010 / 7020 / 7025

Unplug the USB cable and press the **▲** key or **▼** key several times to display “MAINTENANCE 99” code on the LCD. Then press the **Set** key .

6.2 IF YOU REPLACE THE LASER SCANNER UNIT ASSY

[1] Inputting the adjusted value of the laser scanner

- (1) Double-click the brmainte.EXE file (maintenance utility).
- (2) Select Input Information from Menu. Select the applicable model name.
- (3) Check the port (USB) which the machine is connected through.
- (4) Select 'Adjust Scanner' from Menu. Enter the figures (the last four digits) shown on the label attached on the chassis at the right hand side of the main PCB into the box at the right hand side.

6.3 IF YOU REPLACE THE DOCUMENT SCANNER UNIT

[1] Acquire of white level data and set the CIS scanner area (Function code 55)

Refer to Chapter 8. Section 8.4.12

CHAPTER 7

CLEANING

Confidential

CHAPTER 7 CLEANING

For the cleaning procedures of the drum unit and toner cartridge, refer to the User's Guide.

Confidential

CHAPTER 8

MAINTENANCE MODE

Confidential

CHAPTER 8 MAINTENANCE MODE

This chapter describes the maintenance mode which is exclusively designed for the purpose of checks, settings and adjustments using the keys on the control panel.

You can customize the EEPROM according to the shipment destination of the machine concerned. In addition, you can perform operational checks of the LCD, control panel PCB or sensors, perform a print test, display the log information or error codes, and modify firmware switches (WSW).

CONTENTS

8.1	ENTRY INTO THE MAINTENANCE MODE	8-1
8.2	LIST OF MAINTENANCE-MODE FUNCTIONS	8-2
8.3	USER-ACCESS TO THE MAINTENANCE MODE	8-3
8.4	DETAILED DESCRIPTION OF MAINTENANCE-MODE FUNCTIONS	8-5
8.4.1	EEPROM Parameter Initialization (Function code 01/91)	8-5
8.4.2	Printout of Scanning Compensation Data (Function code 05)	8-6
8.4.3	Placement of CIS Unit in Position for Transportation (Function mode 06).....	8-8
8.4.4	ADF Performance Test (Function mode 08)	8-9
8.4.5	Test Pattern 1 (Function mode 09).....	8-10
8.4.6	Firmware Switch Setting and Printout	8-11
8.4.6.1	Firmware switch setting (Function mode 10)	8-11
8.4.6.2	Printout of firmware switch data (Function mode 11).....	8-14
8.4.7	Operation Check of LCD (Function mode 12)	8-16
8.4.8	Operational Check of Control Panel PCB (Function mode 13).....	8-17
8.4.9	Sensor Operational Check (Function mode 32).....	8-18
8.4.10	Received Data Transfer Function (Function mode 53) (MFC7420/7820N only)	8-20
8.4.11	Fine Adjustment of Scan Start/End Positions (Function mode 54)	8-22
8.4.12	Acquisition of White Level Data and CIS Scanner Area Setting (Function mode 55)	8-24
8.4.13	Paper Feeding and Ejecting Test (Function mode 67).....	8-24
8.4.14	EEPROM Customizing (Function mode 74).....	8-25
8.4.15	Display of the Equipment's Log Information (Function mode 80)	8-26
8.4.16	Machine Error Code Indication (Function mode 82).....	8-28
8.4.17	Output of Transmission Log to the Telephone Line (Function mode 87).....	8-28
8.4.18	Cancellation of the Memory Security Mode (Not applicable to the Japanese model).....	8-29

Confidential

8.1 ENTRY INTO THE MAINTENANCE MODE

MFC7420/7820N

Press the **Menu/Set** and **Start** keys. Next press the **▲** key four times to make the machine enter the maintenance mode.

TIP: FAX models equipped with numerical keypads can enter the maintenance mode in the same way as conventional models; that is, by pressing the **Menu/Set**, *****, **2**, **8**, **6** and **4** keys in this sequence.

DCP7010/7020/7025

Press the **Menu** and **Start** keys. Next press the **▲** key four times to make the machine enter the maintenance mode.

The machine beeps for approx. one second and displays "■■ MAINTENANCE ■■■" on the LCD, indicating that it is placed in the initial stage of the maintenance mode, a mode in which the machine is ready to accept entry from the keys.

To select one of the maintenance-mode functions listed in [Section 8.2](#), press the **▲** key or **▼** key to display any function code on the LCD. Then press the **Set** key.

(The details of each maintenance-mode function are described in [Section 8.4](#).)

NOTE:

- MFC7420/7820N

To exit from the maintenance mode and switch to standby, press the **9** key twice in the initial stage of the maintenance mode

- DCP7010/7020/7025

Press the **▲** key or **▼** key several times to display the "MAINTENANCE 99" code on the LCD in the initial stage of the maintenance mode. Then press the **Set** key to switch to standby.

- Pressing the **Stop/Exit** key after entering only one digit restores the machine to the initial stage of the maintenance mode.
- If an invalid function code is entered, the machine resumes the initial stage of the maintenance mode.

8.2 LIST OF MAINTENANCE-MODE FUNCTIONS

Maintenance-mode Functions

Function Code	Function	Reference Section (Page)
01	EEPROM Parameter Initialization	8.4.1 (8-5)
05	Printout of Scanning Compensation Data	8.4.2 (8-6)
06	Placement of CIS Unit Position for Transportation	8.4.3 (8-8)
08	ADF Performance Test	8.4.4 (8-9)
09	Test Pattern 1	8.4.5 (8-10)
10	Firmware Switch Setting	8.4.6.1 (8-11)
11	Printout of Firmware Switch Data	8.4.6.2 (8-14)
12	Operational Check of LCD	8.4.7 (8-16)
13	Operational Check of Control Panel PCB	8.4.8 (8-17)
32	Sensor Operational Check	8.4.9 (8-18)
53	Received Data Transfer Function	8.4.10 (8-20)
54	Fine Adjustment of Scan Start/End Positions	8.4.11 (8-22)
55	Acquisition of White Level Data and CIS Scanner Area Setting	8.4.12 (8-24)
67	Paper Feeding and Ejecting Test	8.4.13 (8-24)
74	EEPROM Customizing	8.4.14 (8-25)
80	Display of the Equipment's Log Information	8.4.15 (8-26)
82	Machine Error Code Indication	8.4.16 (8-28)
87	Output of Transmission Log to the Telephone Line	8.4.17 (8-28)
—	Cancellation of the Memory Security Mode (Not applicable to the Japanese version)	8.4.18 (8-29)

8.3 USER-ACCESS TO THE MAINTENANCE MODE

Basically, the maintenance-mode functions listed on the previous page should be accessed by service personnel only. However, you can allow end users to access some of these under the guidance of service personnel (e.g., by telephone).

The user-accessible functions (codes 06, 09, 10, 11, 12, 53, 54, 80, 82 and 87) are *shaded* in the table given on the previous page. Function code 10 accesses the firmware switches, each of which has eight selectors. You should not allow end users to access all of those selectors, but you can allow them to access user-accessible selectors which are *shaded* in the firmware switch tables in [Appendix 4](#).

The service personnel should instruct end users to follow the procedure given below.

MFC7420/7820N

- (1) Press the **Menu/Set** , **Start**, **Menu/Set** , and **▲** keys in this order.

TIP: For the FAX models equipped with numerical keypads, you may press the **Menu/Set** , **Start**, and **0** keys instead in the same way as conventional models.

The "MAINTENANCE **" appears on the LCD.

- (2) Press the **▲** key or **▼** key several times to display the desired maintenance code on the LCD. Then press the **Menu/Set** key.
- (3) To switch the machine back to the standby state, press the **Stop/Exit** key. When each of the user-accessible functions is completed, the machine automatically returns to the standby state.

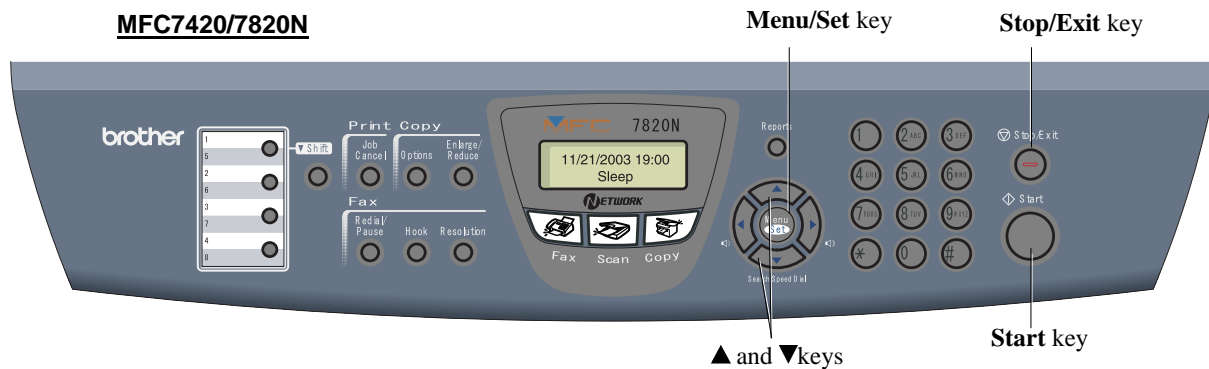

DCP7010/7020/7025

- (1) Press the **Menu**, **Start**, **Menu**, and **▲** keys in this order.

The "MAINTENANCE **" appears on the LCD.

- (2) Press the **Start** key several times to display the desired maintenance code on the LCD.

Then press the **Set** key.

- (3) To make the machine return to the standby state, press the **Stop/Exit** key. When each of the user-accessible functions is completed, the machine automatically returns to the standby state.

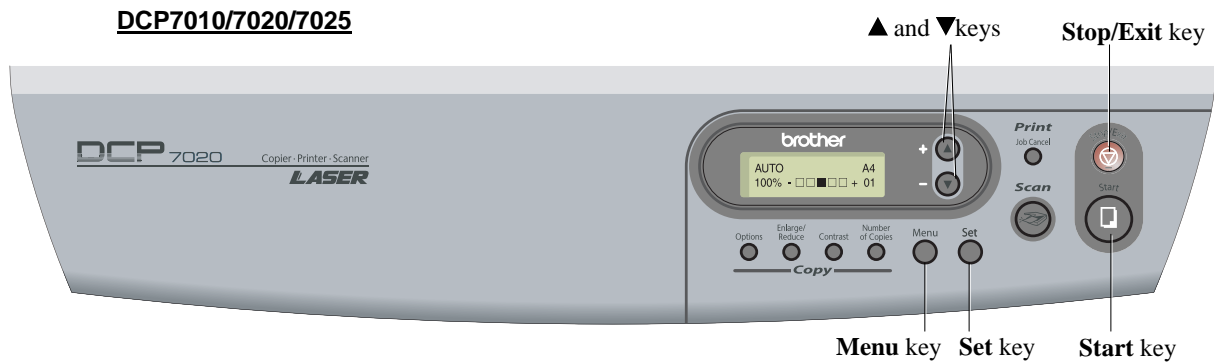

8.4 DETAILED DESCRIPTION OF MAINTENANCE-MODE FUNCTIONS

8.4.1 EEPROM Parameter Initialization (Function code 01/91)

■ Function

The machine initializes the parameters, user switches, and firmware switches registered in the EEPROM, to the initial values. Entering the function code 01 initializes all of the EEPROM areas, but entering 91 does not initialize some areas, as listed below.

Function code	01	91
Data item		
Maintenance-mode functions	All of these will be initialized.	These will be initialized.
User switches		
Firmware switches		
Remote activation code		These will not be initialized.
Station ID data	All of these will be initialized.	These will not be initialized.
Outside line number		
Telephone function registration		
One-touch dialing		
Speed dialing		
Group dialing		

NOTE: If you replace the main PCB with the one used for any other machine, carry out this procedure and then customize the EEPROM (maintenance-mode function code 74 in [Section 8.4.14](#)).

■ Operating Procedure

(1) MFC7420/7820N

Press the **0** and **1** keys (or the **9** and **1** keys according to your need) in this order in the initial stage of the maintenance mode.

DCP7010/7020/7025

Press the **▲** key or **▼** key several times to display the "MAINTENANCE 01" or "MAINTENANCE 91" code on the LCD. Then press the **Set** key .

The "PARAMETER INIT" will appear on the LCD.

- (2) Upon completion of parameter initialization, the machine returns to the initial stage of the maintenance mode.
- (3) Be sure to turn the machine power off. If you press the **9** key twice to exit from the maintenance mode without turning the power off, then the machine will not fully initialize the EEPROM.

8.4.2 Printout of Scanning Compensation Data (Function code 05)

■ Function

The machine prints out the white and black level data for scanning compensation.

■ Operating Procedure

Do not start this function merely after powering on the equipment but start it after carrying out a sequence of scanning operation. Unless the equipment has carried out any scanning operation, this function cannot print out correct scanning compensation data. This is because at the start of scanning operation, the equipment initializes white and black level data and takes in the scanning compensation reference data.

(1) MFC7420/7820N

Press the **0** and **5** keys in this order in the initial stage of the maintenance mode.

DCP7010/7020/7025

Press the **▲** key or **▼** key several times to display the "MAINTENANCE 05" code on the LCD. Then press the **Set** key .

The "WHITE LEVEL 1" will appear on the LCD.

(2) The equipment prints out the scanning compensation data list containing the following:

- | | |
|----------------------------------------------|----------|
| a) Bright output adjustment value (REFH-PWM) | 1Byte |
| b) Illuminant adjustment value (LED-DATA:R) | 1Byte |
| c) Illuminant adjustment value (LED-DATA:G) | 1Byte |
| d) Illuminant adjustment value (LED-DATA:B) | 1Byte |
| e) Black level MIN data | 1Byte |
| f) Black level MAX data | 1Byte |
| g) White level MIN data (R) | 1Byte |
| h) White level MIN data (G) | 1Byte |
| i) White level MIN data (B) | 1Byte |
| j) White level MAX data (R) | 1Byte |
| k) White level MAX data (G) | 1Byte |
| l) White level MAX data (B) | 1Byte |
| m) Background color compensated data | 1Byte |
| n) Black level data | 4960Byte |
| o) White level data (R) | 4960Byte |
| p) White level data (G) | 4960Byte |
| q) White level data (B) | 4960Byte |

(3) Upon completion of recording of the compensation data list, the equipment returns to the initial stage of the maintenance mode.

NOTE: If any data is abnormal, its code will be printed in inline style, as shown on the next page.

8.4.3 Placement of CIS Unit in Position for Transportation (Function code 06)

■ **Function**

This function is to move the CIS unit in position for transportation located at the right end. When you fix the FAX equipment and check its operation, you need to perform this function right before packing and shipping it.

NOTE: Please instruct end users to perform this function if possible before packing and shipping their FAX equipment to a sales agent or a service dealer for the purpose of repair. (For the procedure to allow users to perform maintenance modes, please see [P.8-3.](#))

■ **Operating Procedure**

(1) MFC7420/7820N

Press the **0** and **6** keys in this order in the initial stage of the maintenance mode.

DCP7010/7020/7025

Press the **▲** key or **▼** key several times to display the “MAINTENANCE 06” code on the LCD. Then press the **Set** key .

The CIS unit moves to the designated position for transportation located at the right end. The “MAINTENANCE 06” is displayed until the CIS unit is placed in position. When the CIS unit is placed in the position, the “PLEASE SCAN LOCKED” appears on the LCD.

- (2) Open the document cover, and lock the scanner lock lever at the rear left of the scanner unit. When the scanner lock lever is locked, the “SCAN LOCKED” appears. To terminate this operation, press the **Stop/Exit** key. The machine returns to the initial stage of the maintenance mode.

8.4.4 ADF Performance Test (Function code 08)

■ **Function**

The machine counts the documents fed by the automatic document feeder (ADF) and displays the count on the LCD for checking the ADF performance.

■ **Operating Procedure**

- (1) Set documents. (Allowable up to the ADF capacity.)

The "DOC. READY" will appear on the LCD.

- (2) MFC7420/7820

Press the **0** and **8** keys in this order.

DCP7020/7025

Press the **▲** key or **▼** key several times to display the "MAINTENANCE 08" code on the LCD. Then press the **Set** key .

While counting the documents, the machine feeds them in and out, displaying the current count on the LCD as shown below.

ADF CHECK P.01



Current count (1st page in this example)

- (3) To return the machine to the initial stage of the maintenance mode, press the **Stop/Exit** key.

8.4.5 Test Pattern 1 (Function code 09)

■ **Function**

This function, much like the copying function, prints out test pattern 1 to allow the service personnel to check for record data missing or print quality.

■ **Operating Procedure**

MFC7420/7820N

Press the **0** and **9** keys in this order in the initial stage of the maintenance mode.

DCP7010/7020/7025

Press the **▲** key or **▼** key several times to display the “MAINTENANCE 09” code on the LCD. Then press the **Set** key .

The figure below shows test pattern.

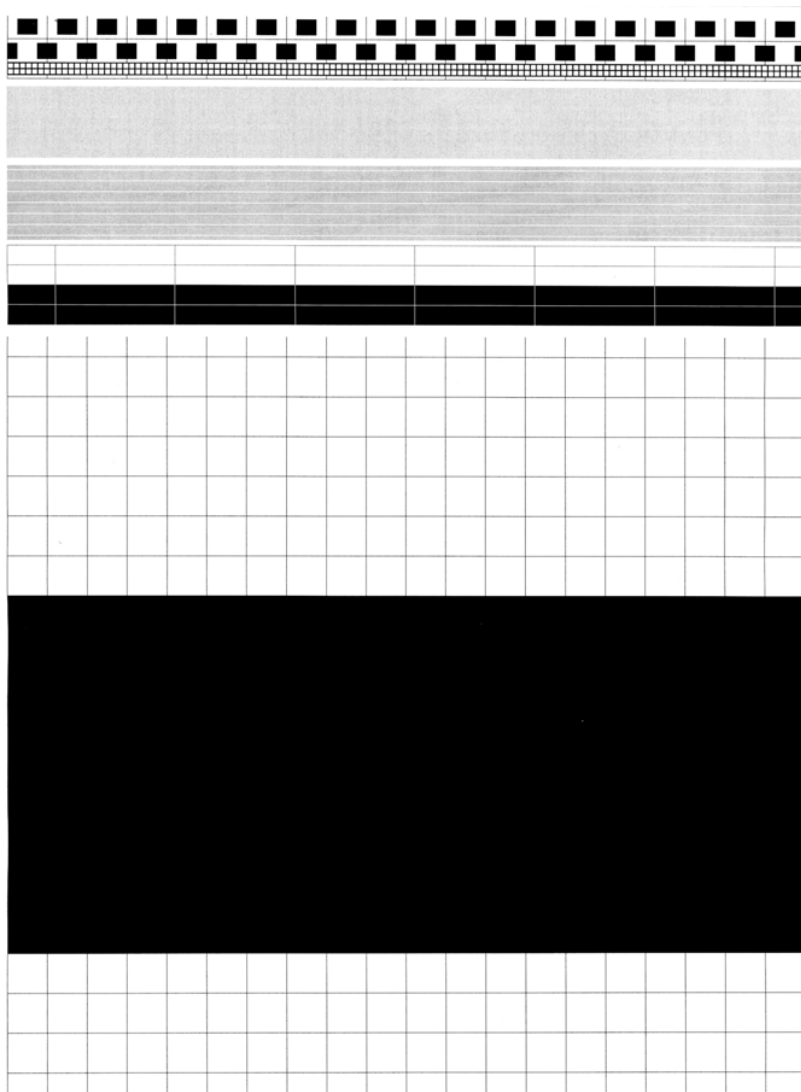

Test Pattern

8.4.6 Firmware Switch Setting and Printout

8.4.6.1 Firmware switch setting (Function code 10)

■ Function

The machine incorporates the following firmware switch functions which may be activated with the procedures using the control panel keys and buttons.

The firmware switches have been set at the factory in conformity to the communications standards and codes of each country. Do not disturb them unless necessary. Some firmware switches may not be applicable in some versions. The firmware switch data list indicates "Not used." for those inapplicable switches.

Firmware Switches (WSW01 through WSW51)

WSW No.	Function
WSW01	Dial pulse setting
WSW02	Tone signal setting
WSW03	PABX mode setting
WSW04	TRANSFER facility setting
WSW05	1st dial tone and busy tone detection
WSW06	Redial/Pause key setting and 2nd dial tone detection
WSW07	Dial tone setting 1
WSW08	Dial tone setting 2
WSW09	Protocol definition 1
WSW10	Protocol definition 2
WSW11	Busy tone setting
WSW12	Signal detection condition setting
WSW13	Modem setting
WSW14	AUTO ANS facility setting
WSW15	REDIAL facility setting
WSW16	Function setting 1
WSW17	Function setting 2
WSW18	Function setting 3
WSW19	Transmission speed setting
WSW20	Overseas communications mode setting
WSW21	TAD setting 1
WSW22	ECM and call waiting caller ID
WSW23	Communications setting
WSW24	TAD setting 2
WSW25	TAD setting 3
WSW26	Function setting 4
WSW27	Function setting 5
WSW28	Function setting 6
WSW29	Function setting 7
WSW30	Function setting 8
WSW31	Function setting 9
WSW32	Function setting 10
WSW33	Function setting 11
WSW34	Function setting 12
WSW35	Function setting 13
WSW36	Function setting 14
WSW37	Function setting 15

Firmware Switches (WSW01 through WSW51) *Continued*

WSW No.	Function
WSW38	V.34 transmission settings
WSW39	V.34 transmission speed
WSW40	V.34 modem settings
WSW41	ON-duration of the scanning light source
WSW42	Internet mail settings
WSW43	Function setting 21
WSW44	Speeding up scanning-1
WSW45	Speeding up scanning-2
WSW46	Monitor of power ON/OFF state and parallel port kept at high
WSW47	Switching between high- and full-speed USB
WSW48	USB setup latency
WSW49	End-of-copying beep and print in black
WSW50	SDAA settings
WSW51	Function setting 16

■ **Operating Procedure**

MFC7420/7820N

(1) Press the **1** and **0** keys in this order in the initial stage of the maintenance mode.
The machine displays the "WSW00" on the LCD and becomes ready to accept a firmware switch number.

(2) Enter the desired number from the firmware switch numbers (01 through 51).
The following appears on the LCD:

Selector 1 Selector 8
 ↓ ↓
 WSWXX = 0 0 0 0 0 0 0

- (3) Use the ◀ and ▶ keys to move the cursor to the selector position to be modified.
- (4) Enter a value to be set (0 or 1) using the **0** and **1** keys.
- (5) Press the **Menu/Set** key. This operation saves the newly entered selector values onto the EEPROM and readies the machine for accepting a firmware switch number.
- (6) Repeat steps (2) through (5) until the modification for the desired firmware switches is completed.
- (7) Press the **Stop/Exit** key to return the machine to the initial stage of the maintenance mode.

NOTE:

- To cancel this operation and return the machine to the initial stage of the maintenance mode during the above procedure, press the **Stop/Exit** key.
- If there is a pause of more than one minute after a single-digit number is entered for double-digit firmware switch numbers, the machine will automatically return to the initial stage of the maintenance mode.

DCP7010/7020/7025

- (1) Press the ▲ key or ▼ key several times to display the “MAINTENANCE 10” code on the LCD. Then press the **Set** key.

The machine displays the "WSW00" on the LCD and becomes ready to accept a firmware switch number.

- (2) Press the ▲ key or ▼ key to display the firmware switch which is desired to be changed on the LCD. Then press the **Set** key .

The following appears on the LCD:

Selector 1 Selector 8
 ↓ ↓
WSWXX = 0 0 0 0 0 0 0 0

- (3) Enter “1” by pressing the ▲ key. Enter “0” by pressing the ▼ key. The cursor will be shifted to the right by one position. Repeat this operation to modify the Selector from Selector 1 to Selector 8.
- (4) Press the **Set** key. This operation saves the newly entered selector values onto the EEPROM and readies the machine for accepting a firmware switch number.
- (5) Repeat steps (2) through (5) until the modification for the desired firmware switches is completed.
- (6) Press the **Stop/Exit** key to return the machine to the initial stage of the maintenance mode.

- NOTES:**
- To cancel this operation and return the machine to the initial stage of the maintenance mode during the above procedure, press the **Stop/Exit** key.
 - If there is a pause of more than one minute after a single-digit number is entered for double-digit firmware switch numbers, the machine will automatically return to the initial stage of the maintenance mode.

■ Details of Firmware Switches

- The details of the firmware switches are described in [Appendix 4](#) in which the user-accessible selectors of the firmware switches are shaded.
- Machine w/o fax support some selectors of firmware switches. Those selector numbers are circled.

8.4.6.2 Printout of firmware switch data (Function code 11)

■ **Function**

The machine prints out the setting items and contents specified by the firmware switches.

■ **Operating Procedure**

(1) MFC7420/7820N

Press the **1** key twice in the initial stage of the maintenance mode.

DCP7010/7020/7025

Press the **▲** key or **▼** key several times to display the "MAINTENANCE 11" code on the LCD. Then press the **Set** key .

The "PRINTING" will appear on the LCD.

- (2) The machine prints out the configuration list as shown in the figure below.
- (3) Upon completion of printing, the machine returns to the initial stage of the maintenance mode.

CONFIGURATION LIST

MODEL : 805-A15
 TIME : 01/13/2005 22:45
 REV. : U0410102155VER.U
 PCI : 5.02
 SUM : BC84
 SER.# : 011000110 ♪

```

WSW01 = 0000010
1-2. DIAL FORMAT : NORMAL
3-4. BREAK TIME : 60 MS
5-6. INTERDIGIT PAUSE : 800 MS
7. DP/PB CHANGE IN USER SW : NO
8. DP/PB FIXING SELECTION : PB
WSW02 = 11111010
1-2. ON TIME : 100 MS
3-4. OFF TIME : 140 MS
5-8. LINE BEEP ATTENUATOR : 10 DB
WSW03 = 10000000
1. PARA. CNG DETECTION1 : B
2-4. NOT USED
5. PARA. CNG DETECTION2 : A
6-8. NOT USED
WSW04 = 00010111
1-6. NOT USED
7-8. FLASHING TIME : 500 MS
WSW05 = 00000110
1-3. DIAL TONE DETECTION : 3.5 SEC WAITING
4. REMOTE ID DETECTION TIMEOUT : 2 SEC
5-6. BUSY TONE DETECTION (CALLING) : AFTER DIALING
7. BUSY TONE DETECTION (CALLED) : OFF
8. NOT USED
WSW06 = 00101100
1-3. PAUSE KEY : 3.5 SEC WAITING
4-6. 2ND DT DETECTION TIME : 800 MS
7. 2ND DT DETECTION CYCLE : 1 CYCLE
8. 2ND DT INTERRUPT DETECTION TIME : 30 MS
WSW07 = 01001100
1-2. FREQUENCY RANGE : INITIAL DATA
3. NOT USED
4-6. 2ND DT DETECTION LEVEL : -30 DBM
7. 1ST DT INTERRUPT DETECTION TIME : 30 MS
8. NOT USED
WSW08 = 01100100
1-3. 1ST DT DETECTION TIME : 800 MS
4-5. 1ST/2ND DT TIME OUT : 10 SEC
6-8. 1ST DT DETECTION LEVEL : -33 DBM
WSW09 = 00000000
1. ECM FRAME : 255 OCTET
2. NON STANDARD FACILITIES : ON
3-4. TIMES OF FALL BACK : 4
5. T5 TIMER : 300 SEC
6. T1 TIMER : 35 SEC
7-8. CALLING TIMEOUT : 55 SEC
WSW10 = 00010100
1. NOT USED
2. TIMING OF LAST DIGIT-MODEM CHANGE : 100 MS
3. TIMING OF OML ON CNG TRANSMISSION : 2 SEC
4. TIMING OF OML ON CED TRANSMISSION : 2 SEC
5-6. TRAINING RETRIES : 2
7. CODING METHOD MR : ON
8. CODING METHOD MMR : ON
WSW11 = 01011000
1-2. FREQUENCY RANGE : INITIAL DATA
3-8. ON/OFF TIME : 175 - 600 / 175 - 600 MS
WSW12 = 10011011
1-2. OFF DETECTION TIME : 700 MS
3-4. AUTO ANS OFF DETECTION TIME : 7 SEC
5-6. ON DETECTION TIME : 250 MS
7-8. NOT USED
    
```

Configuration List

8.4.6.2 Printout of firmware switch data (Function code 11)

■ **Function**

The machine prints out the setting items and contents specified by the firmware switches.

■ **Operating Procedure**

(1) MFC7420/7820N

Press the **1** key twice in the initial stage of the maintenance mode.

DCP7010/7020/7025

Press the **▲** key or **▼** key several times to display the "MAINTENANCE 11" code on the LCD. Then press the **Set** key .

The "PRINTING" will appear on the LCD.

- (2) The machine prints out the configuration list as shown in the figure below.
- (3) Upon completion of printing, the machine returns to the initial stage of the maintenance mode.

8.4.8 Operational Check of Control Panel PCB (Function code 13)

■ **Function**

This function allows you to check the control panel PCB for normal operation.

■ **Operating Procedure**

(1) MFC7420/7820N

Press the **1** and **3** keys in this order in the initial stage of the maintenance mode.

DCP7010/7020/7025

Press the **▲** key or **▼** key several times to display the "MAINTENANCE 13" code on the LCD. Then press the **Set** key.

The "00" will appear on the LCD.

- (2) Press the keys and buttons in the order designated in the illustration shown below. The LCD shows the corresponding number in decimal notation each time a key or button is pressed. Check that the displayed number is correct by referring to the illustration below.

If a key or button is pressed out of order, the machine beeps and displays the "INVALID OPERATE" on the LCD. To return to the status ready to accept key & button entry for operational check, press the **Stop/Exit** key.

- (3) After the last number key or button is pressed, the machine beeps for one second and returns to the initial stage of the maintenance mode. To terminate this operation, press the **Stop/Exit** key. The machine returns to the initial stage of the maintenance mode.

MFC7420/7820N



DCP7010/7020/7025



8.4.9 Sensor Operational Check (Function code 32)

■ **Function**

This function allows you to check whether the 9 sensors.

■ **Operating Procedure**

(1) MFC7420/7820N

Press the **3** and **2** keys in this order in the initial stage of the maintenance mode.

DCO7010/7020/7025

Press the **▲** key or **▼** key several times to display the "MAINTENANCE 32" code on the LCD. Then press the **Set** key .

The machine beeps 1100 Hz and 400 Hz tones cyclically through the following volumes for testing the speaker. To stop beeping, press the **Menu/Set (Set)** key.

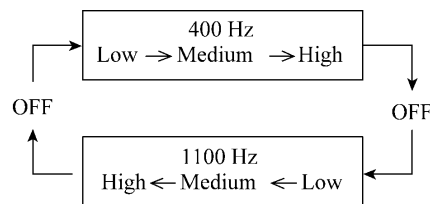

If the sensing status are as listed below, the LCD will show the following: "DFDRCV" and "NTMNRSTNKOFU" (which can be switched by pressing the **Start** key for machines.)

Given below is the relationship between the LCD indication, sensor names and sensor status.

LCD	Sensors	Sensing status
DF*	Document front sensor	No document detected.
DR*	Document rear sensor	No document detected.
CV	Cover sensor	Front cover closed.
NT	New toner sensor	New toner detected.
MN	Manual insertion sensor	No paper detected.
RS	Registration sensor	No paper detected.
TN	Toner sensor	Toner detected.
KO	Tail edge sensor	No paper detected.
FU	Fixing sensor	No recording paper detected.

* MFC7420/7820N and DCP7020/7025 ONLY

- (2) Change the detecting conditions to check that the indication on the LCD changes according to the sensor states. For instance, insert paper through the document front (or rear) sensor or the registration sensor (s), open the front cover or the document cover, remove the toner cartridge, jam paper at the paper outlet, insert paper from the manual feeder, and load a recording paper tray, etc.
- (3) Press the **Stop/Exit** key. The machine beeps for one second and return to the initial stage of the maintenance mode.

NOTE: If you have opened and closed the front cover during the above procedure, you need to open and close the front cover again upon completion of the procedure.

8.4.10 Received Data Transfer Function (Function code 53) (Not applicable to DCP7010/7020/7025)

■ **Function**

This function transfers received FAX data to another machine. It is useful when the machine cannot print received data due to the printing mechanism defective.

NOTE: The number of files that can be transferred at a time is 99. To transfer 100 files or more, carry out the following procedure more than one time.

■ **Operating Procedure**

- (1) Press the **5** and **3** keys in this order in the initial stage of the maintenance mode.
The "FAX TRANSFER" appears on the LCD.
- (2) To check the number of received files, press the **1** key.
The "1.NO. OF JOBS" appears on the LCD.
Press the **Menu/Set** key, and the number of received files appears, just as "NO. OF JOBS: 10."
- (3) To transfer the activity report only, press the **2** key.
The "2.ACTIVITY" appears.
To transfer received files (together with the activity report), press the **3** key.
The "3.DOCUMENTS" appears. Note that if there is no received file, the "NO DOCUMENTS" appears.
- (4) To transfer the communication list for the latest communication, press the **4** key.
The "4.COM.LIST (NEW)" appears.
To transfer the communication list for last three errors, press the **5** key.
The "5.COM.LIST (ERR3)" appears.
- (5) With the "2.ACTIVITY," "3.DOCUMENTS," "4.COM.LIST (NEW)," or "5.COM.LIST (ERR3)" being displayed, press the **Menu/Set** key.
The "ENTER NO. &SET" appears.
- (6) Enter the telephone number of the receiver machine and press the **Menu/Set** key again.

NOTE: Be sure to type the telephone number with the numerical keys. No one-touch dialing is allowed in this procedure.
The machine displays the "ACCEPTED" for approx. two seconds and starts dialing to transfer data.
No station ID will be attached. A cover page and end page as shown on the next page will be automatically attached, instead.

Cover page sample

```

=== FAX TRANSFER COVER PAGE ===

NO. OF JOBS      :001
TOTAL PAGE[S]   :001
NAME            :BROTHER
FAX             :052 824 2330
TEL             :
TIME            :01/02/2004 22:21

8C5-A11
B0403261602
U0404221449 VER.0
G01234567890
  
```

← Job number
 ← Total number of pages to be transferred
 ← Station ID registered in the sender equipment
 ← FAX number of the sender equipment
 ← Telephone number of the sender equipment
 ← Transfer start date
 ← Model code
 ← Boot ROM info
 ← ROM info
 ← Serial number

End page sample

```

=== FAX TRANSFER END PAGE ===

NO. OF JOBS      :001
TOTAL PAGE[S]   :001
NAME            :BROTHER
FAX             :052 824 2330
TEL             :

MACHINE STATUS 1  AF:0401022216
MACHINE STATUS 2  43:0401022216
MACHINE STATUS 3  48:0401022216
MACHINE STATUS 4  AF:0401022017
MACHINE STATUS 5  43:0401022017
MACHINE STATUS 6  48:0401022017
MACHINE STATUS 7  AF:0401011756
MACHINE STATUS 8  43:0401011756
MACHINE STATUS 9  48:0401011756
  
```

← Job number
 ← Total number of pages transferred
 ← Station ID registered in the sender equipment
 ← FAX number of the sender equipment
 ← Telephone number of the sender equipment
 ← Error codes

8.4.11 Fine Adjustment of Scan Start/End Positions (Function code 54) (Not applicable to DCP7010/7020/7025)

■ **Function**

This function is to adjust the scan start/end positions.

■ **Operating Procedure**

- (1) Press the **5** and **4** keys in this order in the initial stage of the maintenance mode.
The “SCAN START ADJ.” will appear on the LCD.
- (2) The “1. ADF 2. FB” will appear.
Select one of them that you want to adjust the start position.

If you want to adjust the start position of the ADF, press **1** key, and if you want to adjust that of the FB unit, press **2** key.
- (3) The present compensation level for the start position appears on the LCD.
Compensation levels can be adjusted in 11 steps from +5 to -5 (mm).
- (4) Press the ◀ key to increase compensation levels, and the ▶ key to lower them.
Press the **Stop/Exit** key, and the machine returns to the initial state of the maintenance mode without adjusting compensation levels.
- (5) Press the **Menu/Set** key.
The “ACCEPTED” will appear on the LCD. One second later, the machine “1. ADF_2. FB “ will appear on the LCD.
- (6) Press the **Stop/Exit** key when finish the adjustment. The machine returns to the initial state of the maintenance mode.

NOTE: The correlation between the scan start/end positions and compensation levels is shown next page.

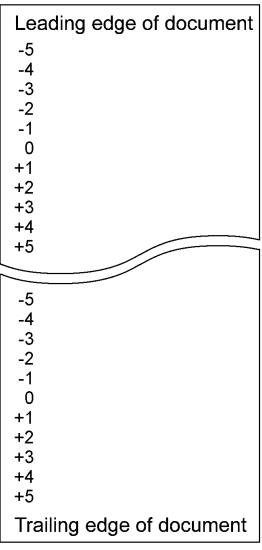
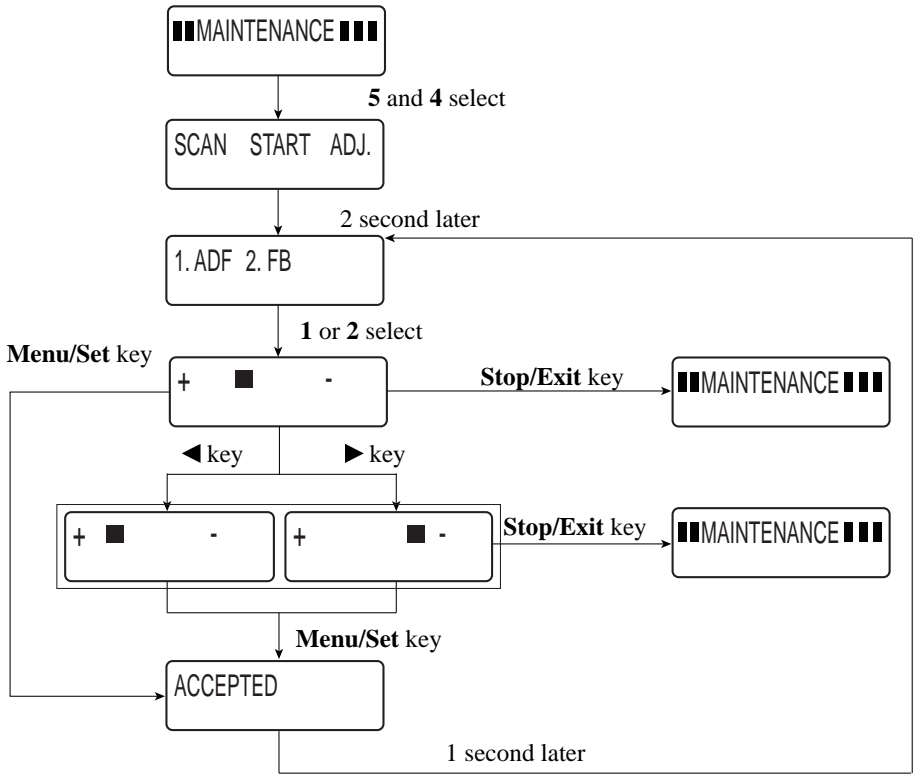

8.4.12 Acquisition of White Level Data and CIS Scanner Area Setting (Function code 55)

■ **Function**

This function allows the machine to obtain white level data for the CIS scanner and save it together with the CIS scanner area into the EEPROM on the main PCB.

■ **Operating Procedure**

(1) MFC7420/7820N

Press the **5** key twice in the initial stage of the maintenance mode.

DCP7010/7020/7025

Press the **▲** key or **▼** key several times to display the "MAINTENANCE 55" code on the LCD. Then press the **Set** key .

The "SCANNER AREA SET" will appear on the LCD.

The machine automatically obtains white level data.

(2) If this operation completes normally, the machine returns to the initial stage of the maintenance mode.

If any error is noted, the "SCANNER ERROR" appears on the LCD. To return the machine to the initial stage of the maintenance mode, press the **Stop/Exit** key.

8.4.13 Paper Feeding and Ejecting Test (Function code 67)

■ **Function**

This function allows you to check that a sheet of paper is fed and ejected correctly by printing the grid pattern on a page, whose interval is 1cm.

■ **Operating Procedure**

(1) MFC7420/7820N

Press the **6** and **7** keys in this order in the initial stage of the maintenance mode.

DCP7010/7020/7025

Press the **▲** key or **▼** key several times to display the "MAINTENANCE 67" code on the LCD. Then press the **Set** key .

The "PAPER FEED TEST" will appear on the LCD.

The test printing is started, and the grid pattern is printed.

(2) To return the machine to the initial stage of the maintenance mode, press the **Stop/Exit** key.

NOTE: In the case that the front cover is opened, or that there is no paper in the tray during test printing, the test printing is stopped.

8.4.14 EEPROM Customizing (Function code 74)

■ **Function**

This function allows you to customize the EEPROM according to language, function settings, and firmware switch settings. The customizing codes list is given in [Appendix 3](#).

NOTE: If you replace the main PCB, be sure to carry out this procedure.

■ **Operating Procedure**

(1) MFC7420/7820N

Press the **7** and **4** keys in this order in the initial stage of the maintenance mode.

DCP7010/7020/7025

Press the **▲** key or **▼** key several times to display the “MAINTENANCE 74” code on the LCD. Then press the **Set** key .

The current customizing code (e.g., 0002 in the case of MFC7820N CANADA model) appears.

(2) Enter the desired customizing code (e.g., 8001 in the case of MFC7820N U.S.A. model). The newly entered code appears.

MFC7420/7820N

To enter letters "A" through "F," press the **1** through **6** keys while holding down the **#** key, respectively.

DCP7010/7020/7025

To enter the customizing code, use the **▲** key, **▼** key and **Set** keys. The numerical value rises when press the **▲** key and falls when press the **▼** key. The digit with a cursor is input when press the **SET** key, and the curser shifts to the next digit.

NOTE: The machine does not work properly when an incorrect code is entered.

(3) Press the **Start** key.

The machine saves the setting and appears the “PARAMETER INIT” on the LCD. The machine returns to the initial stage of the maintenance mode.

If you press the **Stop/Exit** key or no keys are pressed for one minute in the above procedure, the machine stops the procedure and returns to the initial stage of the maintenance mode.

8.4.15 Display of the Equipment's Log Information (Function code 80)

■ **Function**

The equipment may display its log information on the LCD.

■ **Operating Procedure**

(1) MFC7420/7820N

Press the **8** and **0** keys in this order in the initial stage of the maintenance mode.

DCP7010/7020/7025

Press the **▲** key or **▼** key several times to display the "MAINTENANCE 80" code on the LCD. Then press the **Set** key .

The USB serial number appears on the LCD.

(2) Press the **Start** key. Each time the **Start** key is pressed, one of the following log information items appears on the LCD in the order given below.

- 1) Jam count, indicating how many times a paper jam has been occurred
- 2) Page count, indicating how many pages the photosensitive drum has been printed
- 3) Total page count, indicating how many pages the equipment has been printed since produced
- 4) Drum count, indicating how many times the photosensitive drum has been rotated
- 5) Drum change count, indicating how many times drum replacement has been made
- 6) Toner change count, indicating how many times toner replacement has been made
- 7) Copy page count, indicating how many copies have been made
- 8) PC print page count, indicating how many pages the equipment has been printed as an output device of the connected PC
- 9) FAX page count, indicating how many received FAX pages have been printed
- 10) Error code of the most recent machine error *₁
- 11) Error code of the most recent communications error *₂
- 12) ADF jam count, indicating how many times a document jam has been occurred
- 13) ADF page count, indicating how many documents have been fed

(3) To stop this operation and return to the equipment to the initial stage of the maintenance mode, press the **Stop/Exit** key.

*₁ When you press the **Menu/Set (Set)** key while the MACHINE ERR error code is displayed, the last error code is displayed. Each time the **Menu/Set (Set)** key is pressed, up to the ten error codes are displayed one by one in reverse order.

*₂ When you press the **Menu/Set (Set)** key while the COMEER1 error is displayed, the last error, the previous error, and the second previous error are displayed in turn. The indication changes from COMEER1, COMEER2, to COMEER3.

USB:	USB Serial No.
DRUM:	Drum counter
COVERAGE:	Average black coverage
TTL_PG:	Total number of pages printed
COPY:	Number of copies made
PC PRINT:	Number of PC prints made
FAX: *1	Number of FAX outputs made
TR1_PG:	Number of pages picked up from the paper tray
MN_PAGE:	Number of pages picked up from the manual tray
A4+LTR:	Number of A4/Letter size sheets picked up
LG+A4L:	Number of Legal/A4-Long size sheets picked up
B5+EXE:	Number of B5/Executive size sheets picked up
ENVLOP:	Number of envelopes picked up
OTHER:	Number of other-size sheets picked up
TTL_JAM:	Total number of jams
TR1_JAM	Number of jams that occurred at the paper tray
MN_JAM	Number of jams that occurred at the manual tray
IN_JAM	Number of jams that occurred at the feeding
RE_JAM	Number of jams that occurred at the ejecting
DRUM_CH	Number of times the drum has been replaced
DRUM_PG	Number of pages printed by a drum
TNER_CH	Number of times the toner cartridge has been replaced
TNER_PG1	Number of pages printed with the current toner cartridge
TNER_PG2	Number of pages printed with the previous toner cartridge
DEV_BIAS	Current bias voltage
MACHINE_ERR_01 to 10	Last machine error code 01 to 10
ADF_JAM *2	Number of document jams that occurred at the ADF
ADF_PG *2	Number of scanned pages from the ADF
FB_PG	Number of scanned pages from the FB
COMERR1 to 3	Last communication error code 1 to 3

*1.NOT applicable to DCP 7010/7020/7025

*2.NOT applicable to DCP 7010

8.4.16 Machine Error Code Indication (Function code 82)

■ Function

This function displays an error code of the last error on the LCD.

■ Operating Procedure

(1) MFC7420/7820N

Press the **8** and **2** keys in this order in the initial stage of the maintenance mode.

DCP7010/7020/7025

Press the **▲** key or **▼** key several times to display the "MAINTENANCE 82" code on the LCD. Then press the **Set** key.

The LCD shows the "MACHINE ERROR X X."

(2) Press the **Stop/Exit** key. Return to the initial stage of the maintenance mode.

8.4.17 Output of Transmission Log to the Telephone Line (Function code 87) (Not applicable to DCP7010/7020/7025)

■ Function

This function outputs the transmission log (that the machine has stored about the latest transmission) to the telephone line. It allows the service personnel to receive the transmission log of the user's machine at a remote location and use it for analyzing problems arising in the user's machine.

■ Operating Procedure

(1) If the user's machine has a transmission-related problem, call the user's machine at a remote location from your machine.

(2) If the line is connected, have the user perform the following:

1) Hook up to the external phone.

2) Press the **Menu/Set**, **Start**, **Menu/Set**, **Start** keys in this order.

3) Press the **8** and **7** keys.

The above operation makes the user's machine send CNG to your machine for sending the transmission log.

(3) If you hear the CNG sent from the user's machine, press the **Start** key of your machine. Your machine will start to receive the transmission log from the user's machine.

8.4.18 Cancellation of the Memory Security Mode (Not applicable to DCP7010/7020/7025 and the Japanese model)

■ Function (Not applicable to DCP7010/7020/7025)

This procedure can cancel the memory security mode. Use this procedure if the user forgets his/her password entered when setting the memory security mode so as not to exit from the memory security mode.

NOTE: Carrying out this procedure will lose passwords previously entered but retain FAX messages received in the memory security mode.

■ Operating Procedure

- (1) When the SECURE MODE is displayed on the LCD, press the **Menu/Set** key and # key together. Within two seconds, start to press the **2, 7, 9, 0** and **0** keys.
The memory security mode will be canceled and the machine returns to the calendar clock screen.

CHAPTER 9

ERROR INDICATION AND TROUBLESHOOTING

Confidential

CHAPTER 9 ERROR INDICATION AND TROUBLESHOOTING

This chapter details error messages and codes that the incorporated self-diagnostic functions display if any error or malfunction occurs. If any error message appears, refer to this chapter to find which components should be checked or replaced.

The latter half of this chapter provides sample problems that could occur in the main sections of the machine and related troubleshooting procedures. This will help service personnel pinpoint and repair defective components.

CONTENTS

9.1	ERROR INDICATION.....	9-1
9.1.1	Equipment Errors	9-1
[1]	Error messages appearing on the LCD	9-1
[2]	Error codes shown in "MACHINE ERROR X X" messages.....	9-5
9.1.2	Communications Errors.....	9-11
9.2	TROUBLESHOOTING	9-15
9.2.1	Introduction.....	9-15
9.2.2	Precautions	9-15
9.2.3	Checking Prior to Troubleshooting.....	9-15
9.2.4	Troubleshooting Based on Problem Type.....	9-16
[1]	Paper feeding problems	9-16
[2]	Software setting problems	9-18
[3]	Malfunction.....	9-21
[4]	Image defects	9-27
[5]	Incorrect printout	9-48
[6]	Network problem.....	9-50
[7]	Troubleshooting of the control panel.....	9-54
[8]	Troubleshooting of fax functions	9-56

Confidential

9.1 ERROR INDICATION

To help the user or the service personnel promptly locate the cause of a problem (if any), the facsimile equipment incorporates the self-diagnostic functions which display error messages for equipment errors and communications errors.

For the communications errors, the equipment also prints out the transmission verification report and the communications list.

9.1.1 Equipment Errors

If an equipment error occurs, the facsimile equipment emits an audible alarm (continuous beeping) for approximately 4 seconds and shows the error message on the LCD. For the error messages, see [1] below.

To display detailed error information, use maintenance-mode function code 82 described in [Chapter 8, Section 8.4.16](#) (that is, make the equipment enter the maintenance mode and then press the **8** and **2** keys). Following the MACHINE ERROR, one of the error codes listed in [2] will appear on the LCD.

[1] Error messages appearing on the LCD

ERROR MESSAGE	CAUSE	ACTION
Back Cover Open	The back cover is not completely closed.	Close the back cover of the MFC.
Change Drum Soon	The drum unit is near the end of its life.	Use the drum unit until you have a print quality problem; then replace the drum unit with a new one.
Comm. Error	Poor phone line quality caused a communication error.	Send the fax again or connect the MFC to another telephone line. If the problem continues, call the telephone company and ask them to check your phone line.
Connection Fail	You tried to poll a fax machine that is not in Polled Waiting mode.	Check the other fax machine's polling setup.
Cooling Down Wait For a While	The temperature of the drum unit or toner cartridge is too hot. The MFC will pause its current print job and go into cooling down mode. During the cooling down mode, you will hear the cooling fan running while the display on the MFC shows Cooling Down, and Wait For a While.	You must wait 20 minutes for it to cool.
Cover is Open	The front cover is not completely closed.	Close the front cover of the MFC.
Document Jam	The document was not inserted or fed properly, or the document scanned from ADF was longer than 35.4 inches (90 cm).	Remove the document in the ADF.

ERROR MESSAGE	CAUSE	ACTION
Data Remaining	Print data is left in the MFC's memory.	Re-start printing from your computer.
	Print data is left in the MFC's memory. The USB cable was unplugged while the computer was sending the data to the MFC.	Press Job Cancel . The MFC will cancel the job and clear it from the memory.
Disconnected	The other person or other person's fax machine stopped the call.	Try to send or receive again.
Dust on Drum	The drum unit needs to be cleaned.	Cleaning the drum unit.
DR Mode in Use	The MFC is set to Distinctive Ring mode. You can not change the Receive Mode from Manual to another mode.	Set Distinctive Ring to Off.
Unit is too Hot	The fuser unit is too hot.	<p>(For MFC-7420) When you turn off the MFC's power switch its memory will be cleared. If there are faxes, you need to save them before following the suggestions below. Then, turn off the MFC's power switch. Check the MFC's environment. If it is in a location that is too hot or too cold, try to cool or warm the room by turning on the air conditioner or heater. Or, move the MFC to another location. Then, turn on the MFC's power switch.</p> <p>(For MFC-7820N) Turn off the MFC's power switch, and check the MFC's environment. If it is in a location that is too hot or too cold, try to cool or warm the room by turning on the air conditioner or heater. Or, change the location. Then, turn on the MFC's power switch. (The MFC can be turn off for up to 4 days without losing faxes stored in the memory.)</p>
Fail to Warm up	The fuser unit is too cold.	

ERROR MESSAGE	CAUSE	ACTION
Machine too Hot	The inside of the machine is too hot.	Make sure that the fan in the MFC is spinning and the exhaust outlet is not blocked by something. If the fan is spinning, remove some obstacles around the exhaust outlet, and then leave the MFC turned on but do not use it for several minutes. If the fan is not spinning, you need to save the faxes before you follow the suggestions below. Then, turn off the MFC and then on again.
No Cartridge	The toner cartridge is not installed properly.	Reinstall the toner cartridge.
No Paper Fed	The MFC is out of paper or paper is not properly loaded in the paper tray.	Refill the paper in the paper tray. —OR— Remove the paper and load it again.
	The paper is jammed in the MFC.	Remove the jammed paper.
No Response/Busy	The number you dialed does not answer or is busy.	Verify the number and try again.
Not Registered	You tried to access a One-Touch or Speed Dial number that is not programmed.	Set up the One-Touch or Speed Dial number.
Out of Memory	The MFC's memory is full.	(Fax sending or copy operation in progress) Press Start to send or copy the scanned pages. —OR— Press Stop/Exit and wait until the other operations in progress have finished and then try again. —OR— Clear the faxes from the memory. (Printing operation in process) Reduce print resolution. (See Advanced tab in Software User's Guide on the CD-ROM.) —OR— Clear the faxes from the memory.
Paper Jam Inside	The paper is jammed inside the MFC.	Remove the jammed paper.
Paper Jam Rear	The paper is jammed in the back of the MFC.	Remove the jammed paper.
Paper Jam Tray	The paper is jammed in the paper tray of MFC.	Remove the jammed paper.

ERROR MESSAGE	CAUSE	ACTION
Scanner Locked	The scanner glass's sensor does not move to the home position.	(For MFC-7420) Check whether the MFC has faxes in its memory. If there are faxes save them. Then, turn off the MFC and then on again. (For MFC-7820N) Turn off the MFC and then on again.
Toner Life End	The toner cartridge and drum unit assembly may have been installed improperly.	Re-install the toner cartridge and drum unit assembly.
	The toner cartridge is used up and printing is not possible.	Replace the toner cartridge with a new one.
Toner Low	If the LCD shows Toner Low, you can still print, however, the MFC is telling you that toner is near end of its life and will soon run out.	Order a new toner cartridge now.
Unable to Init. (Initialize) Unable to Print Unable to Scan	The MFC has a mechanical problem. —OR— A foreign object, such as a clip or ripped paper, is in the MFC.	(For MFC-7420) Check whether the MFC has faxes in its memory. If there are faxes save them. Turn off the MFC's power switch, and then on again. If the error message continues, leave the MFC for several minutes and try it again. (For MFC-7820N) Turn off the MFC's power switch, and then on again. If the error message continues, leave the MFC for several minutes and try it again.
Wrong Paper Size	Paper is not the correct size.	Load the correct size of paper (Letter, Legal or A4) and then press Start .

[2] Error codes shown in the "MACHINE ERROR X X" message

Error Code (Hex)	Symptom	Probable Cause	Solution
56	The back cover is opened.	The back cover is opened.	Close the back cover.
57-5A	Not used.		
5B	New toner sensor Error (New toner sensor stays on)	New toner actuator lever broken	Replace the new toner actuator.
		New toner sensor defective	Replace the new toner sensor.
5C	Not used.		
5D-69	Not used.		
6A	Heater warming-up timeout error. (Heater does not reach 60 °C within 11 second.)	Thermistor defective	Replace the thermistor.
		Halogen lamp defective	Replace the halogen lamp.
6B	Heater warming-up timeout error. (Heater does not reach 100 °C within 15 second.)	Thermistor defective	Replace the thermistor.
		Halogen lamp defective	Replace the halogen lamp.
6C	Heater temperature exceeds the maximum high temperature. (270°C or more is detected for 1sec.)	Thermistor defective	Replace the thermistor.
		Power supply PCB defective	Replace the power supply PCB.
6D	Not used.		
6E	Heater temperature does not go up enough.	Halogen lamp defective	Replace the halogen lamp.
		Power supply PCB defective	Replace the power supply PCB.
6F	Heater hard limiter operates.	Thermistor defective	Replace the thermistor.
		Power supply PCB defective	Replace the power supply PCB.
70	Not used.		
71	Scanner motor does not synchronize with the reference clock.	Laser unit defective	Replace the laser unit
		Main PCB defective	Replace the main PCB
72	Cannot detect Beam Detect signal.	Laser unit defective	Replace the laser unit
		Main PCB defective	Replace the main PCB
73	The drum unit is not mounted. (Not used)		
74	Toner empty	Toner sensor defective	Replace the toner sensor.
		Toner empty	Replace the toner cartridge.
75	In casing temperature error.	Thermistor in the Frame L ASSY defective	Replace the Thermistor in the Frame L ASSY.

Error Code (Hex)	Symptom	Probable Cause	Solution
76	Heater overheats.	Thermistor in the fixing unit defective	Replace the thermistor in the fixing unit.
		PS PCB unit defective	Replace PS PCB unit.
		Main PCB defective	Replace the main PCB.
77	The power supply is turned off when the error 76 or 78 occurs.	---	---
78	Temperature of the heater does not rise.	Poor connection in the harness of the halogen lamp	Reinsert and adjust the harness
		Halogen lamp defective	Replace halogen lamp.
		Thermistor defective	Replace the thermistor
		PS PCB unit defective	Replace PS PCB unit.
		Main PCB defective	Replace the main PCB.
79	In casing temperature sensor harness disconnected or broken. (Not used.)		
7A	Main motor does not synchronize with the reference clock.	Main PCB defective	Replace the main PCB.
		Main motor defective	Replace the main motor.
7B	ASIC error on the main PCB. (Not used.)		
7C-7F	Not used.		

The solution when Error Code 76,77,78 shown in the machine:

It's possible that the temperature of the heater rises when these kinds of error occur. Therefore, the heater is programmed to turn off the power for 10 minutes after the switch is on for the safety concern when the error occurs.

To help the heater work properly, it's necessary to follow the operating procedures as below after taking measures against the cause of the error.

1. Turn off the switch. Wait until the temperature of the heater lowers enough.
2. Turn on the switch.
3. Display the maintenance mode, then switch to the desired mode or keep the power on for 10 minutes.

80	AT the start of FAX message printing, the controller detects that paper is smaller than A4 size in length.	Paper smaller than the specified size loaded in the paper tray	Load the correct size of paper.
		Main PCB defective	Replace the main PCB.
81	Recording paper jam. (Not used.)		
82	Recording paper jam in paper pull-in operation. (Not used)		
83	Recording paper jam. (The registration sensor comes ON too early in the paper feeding operation.)	Paper is not correctly set in the paper tray	Reload paper.
		Separation pad damaged	Replace the paper tray.
		Registration sensor actuator unhooked	Set the registration sensor actuator into place.
		Main PCB defective	Replace the main PCB.
84	Recording paper jam. (The registration sensor stays ON after completion of paper ejection operation.)	The paper ejection roller does not rotate correctly	Replace the paper ejection roller.
		Foreign materials in the paper path.	Remove foreign materials.
		Registration sensor actuator caught on the surrounding parts	Correct the surrounding parts on which the actuator caught.
		Registration sensor broken	Replace the sensor PCB.
		Main PCB defective	Replace the main PCB.
85	No paper tray loaded. (Not used.)		
86	Not used.		
87	The main motor stops abnormally. (Not used.)		
88	Recording paper jam. (Even after paper pulling-in operation, the registration sensor is still OFF.)	Recording paper not loaded correctly	Instruct the user to load the recording
		Registration sensor broken	Replace the registration sensor.
		Separation pad damaged	Replace the paper tray.
		Objects, such as bits of paper or chips, are in the paper tray or paper tray	Remove the objects from the paper tray.
		Paper pick up roller defective	Replace the paper pick up roller.
		Paper feed motor broken	Replace the paper feed motor ASSY.
		Main PCB defective	Replace the main PCB.

Error Code (Hex)	Symptom	Probable Cause	Solution
89	Not used.		
8A	The paper feed motor does not rotate. (Not used.)		
8B	The paper feed motor stops suddenly. (Not used.)		
8C	Not used.		
8D-A0	Not used.		
A1	Front cover (scanner unit) opened.	Hook of the front open switch on the front cover broken	Replace the front cover.
A2	Document length exceeding the scan limitation. During scanning, 90 cm or longer of a document is detected. During document feeding or ejecting, 400 cm or longer of a document is detected.	Front open switch broken	Replace the front open switch.
		Document jam	Remove the jammed document.
A3	The document rear sensor does not come ON during document pull-in operation.	Document rear sensor actuator caught on the surrounding parts	Correct the surrounding parts on which the actuator caught.
		Document rear sensor broken	Replace the document rear sensor.
		Document jam	Remove the jammed document.
A4	50% or more faulty of white level data. (Not used.)		
A5	FAX scanning failure. (1st time)	CIS defective White-level reference film stained in the scanner cover	Replace the scanner cover (scanner unit).
A6	FAX scanning failure. (retry)		
A7-AB	Not used.		
AC	Less than 50% faulty of white level data. (Not used.)		

Error Code (Hex)	Symptom	Probable Cause	Solution
AD-AE	Not used.		
AF	CIS positioning error.	CIS flat cable broken or not connected	Correct the cable connection. Replace the scanner cover (scanner unit).
		CIS motor harness not connected properly	Correct the harness connection.
		CIS defective	Replace the scanner cover (scanner unit).
		Main PCB defective	Replace the main PCB.
B0	Not used.		
B1	Dark level offset data level error for scanning. (Not used.)		
B2	Gain control data level error for scanning. (Not used.)		
B3	Scan area left edge detection error. (Not used.)		
B4	Scan area right edge detection error. (Not used.)		
B5	Horizontal scanning edge reduction detection error in scanning area setting (Not used.)		
B6	Horizontal scanning edge enlargement detection error in scanning area setting (Not used.)		
B7	A/D converter reference voltage error (at High level).	Main PCB defective	Replace the main PCB.
B8	A/D converter reference voltage error (at Low level). (Not used.)		
B9	Light emission intensity error of the LED array (Exceeding the upper limit).	CIS defective	Replace the scanner cover (scanner unit).
		Main PCB defective	Replace the main PCB.
BA	Not used.		
BB	White level data error.	CIS defective	Replace the scanner cover (scanner unit).
		Main PCB defective	Replace the main PCB.

Error Code (Hex)	Symptom	Probable Cause	Solution
BC	Not used.		
BD	Black level data error.	CIS defective	Replace the scanner cover (scanner unit).
		Main PCB defective	Replace the main PCB.
BE	Scan starting edge detection error. (Not used.)		
BF-CF	Not used.		
D0-DF	Modem error.	Main PCB defective	Replace the main PCB.
E0-E3	Not used.		
E4	Out of recording paper. (Not used.)		
E5	Not used.		
E6	Write error in EEPROM.	Main PCB defective	Replace the main PCB.
E7	Not used.		
E8	Data scanning error during transmission.	CIS defective	Replace the scanner cover (scanner unit).
		Main PCB defective	Replace the main PCB.
E9	Not used.		
EA	Document removed at phase B.	Document front sensor actuator caught on the surrounding parts	Correct the surrounding parts on which the actuator caught.
		Sensor PCB defective	Replace the sensor PCB.
		Main PCB defective	Replace the main PCB.
EB-ED	Not used.		
EE-F2	Not used.		
F3, F5	Internal software error. (Not used.)		
F4	Not used.		
F6	PC interface error. (Not used.)		
F7-FE	Not used.		
FF	Memory management error. (Not used.)		

9.1.2 Communications Errors

If a communications error occurs, the facsimile equipment

- (1) emits an audible alarm (intermittent beeping) for approximately 4 seconds,
- (2) displays the corresponding error message, and
- (3) prints out the transmission verification report if the equipment is in sending operation.

■ Definition of error codes on the communications list

(1) Calling

Code 1	Code 2	Causes
10	08	Wrong number called.
11	01	No dial tone detected before start of dialing.
11	02	Busy tone detected before dialing.
11	03	2nd dial tone not detected.
11	05	No loop current detected. *
11	06	Busy tone detected after dialing or called.
11	07	No response from the remote station in sending.
11	10	Unobtainable tone detected after dialing.
17	07	No response from the calling station in receiving.

* Available in German models only.

(2) Command reception

Code 1	Code 2	Causes
20	01	Unable to detect a flag field.
20	02	Carrier was OFF for 200 ms or longer.
20	03	Abort detected ("1" in succession for 7 bits or more).
20	04	Overrun detected.
20	05	A frame for 3 seconds or more received.
20	06	CRC error in answerback.
20	07	Error command received.
20	08	Invalid command received.
20	09	Command ignored once for document setting or for dumping-out at turn-around transmission.
20	0A	T5 time-out error
20	0B	CRP received.
20	0C	EOR and NULL received.

(3) Compatibility [checking the NSF and DIS]

Code 1	Code 2	Causes
32	01	Remote terminal only with V.29 capability in 2400 or 4800 bps transmission.
32	02	Remote terminal not ready for polling.
32	10	Remote terminal not equipped with password function or its password switch OFF.
32	11	Remote terminal not equipped with or not ready for confidential mailbox function.
32	12	Remote terminal not equipped with or not ready for relay broadcasting function.
32	13	No confidential mail in the remote terminal.
32	14	The available memory space of the remote terminal is less than that required for reception of the confidential or relay broadcasting instruction.
32	18	Remote terminal not equipped with color function.

(4) Instructions received from the remote terminal [checking the NSC, DTC, NSS, and DCS]

Code 1	Code 2	Causes
40	02	Illegal coding system requested.
40	03	Illegal recording width requested.
40	05	ECM requested although not allowed.
40	06	Polled while not ready.
40	07	No document to send when polled.
40	10	Nation code or manufacturer code not coincident.
40	13	Polled by any other manufacturers' terminal while waiting for secure polling.
40	17	Invalid resolution selected.
40	20	Invalid full-color mode requested.

(5) Command reception [checking the NSF and DIS after transmission of NSS and DCS]

Code 1	Code 2	Causes
50	01	Vertical resolution capability changed after compensation of background color.

(6) ID checking

Code 1	Code 2	Causes
63	01	Password plus "lower 4 digits of telephone number" not coincident.
63	02	Password not coincident.
63	03	Polling ID not coincident.

(7) DCN reception

Code 1	Code 2	Causes
74		DCN received.

(8) TCF transmission/reception

Code 1	Code 2	Causes
80	01	Fallback impossible.

(9) Signal isolation

Code 1	Code 2	Causes
90	01	Unable to detect video signals and commands within 6 seconds after CFR is transmitted.
90	02	Received PPS containing invalid page count or block count.

(10) Video signal reception

Code 1	Code 2	Causes
A0	03	Error correction sequence not terminated even at the final transmission speed for fallback.
A0	11	Receive buffer empty. (5-second time-out)
A0	12	Receive buffer full during operation except receiving into memory.
A0	13	Decoding error continued on 500 lines.
A0	14	Decoding error continued for 10 seconds.
A0	15	Time-out: 13 seconds or more for one-line transmission.
A0	16	RTC not found and carrier OFF signal detected for 6 seconds.
A0	17	RTC found but no command detected for 60 seconds.
A0	18	Receive buffer full during receiving into memory.
A0	19	No video data to be sent
A8	01	RTN, PIN, or ERR received at the calling terminal. *
A9	01	RTN, PIN, or ERR received at the called terminal. *

* Available in German models only

(11) General communications-related

Code 1	Code 2	Causes
B0	02	Unable to receive the next-page data.
B0	03	Unable to receive polling even during turn-around transmission due to call reservation.
B0	04	PC interface error.

(12) Maintenance mode

Code 1	Code 2	Causes
E0	01	Failed to detect 1300 Hz signal in burn-in operation.
E0	02	Failed to detect PB signals in burn-in operation.

(13) Equipment error

Code 1	Code 2	Causes
FF	<u>X</u> <u>X</u>	Equipment error (For <u>X</u> <u>X</u> , refer to Section 9.1.1 [2] .)

9.2 TROUBLESHOOTING

9.2.1 Introduction

This section gives the service personnel some of the troubleshooting procedures to be followed if an error or malfunction occurs with the facsimile equipment. It is impossible to anticipate all of the possible problems which may occur in future and determine the troubleshooting procedures, so this section covers some sample problems. However, those samples will help service personnel pinpoint and repair other defective elements if he/she analyzes and examines them well.

9.2.2 Precautions

Be sure to observe the following to prevent the secondary troubles from happening:

- (1) Always unplug the AC power cord from the outlet when removing the covers and PCBs, adjusting the mechanisms, or conducting continuity testing with a circuit tester.
- (2) When disconnecting the connectors, do not pull the lead wires but hold the connector housings.
- (3) Before handling the PCBs, touch a metal portion of the machine to discharge static electricity charged in your body.
When repairing the PCBs, handle them with extra care.

After repairing the defective section, be sure to check again if the repaired section works correctly. Also record the troubleshooting procedure so that it would be of use for future trouble occurrence.

9.2.3 Checking Prior to Troubleshooting

Prior to proceeding to the troubleshooting procedures given in [Section 9.2.4](#), make the following initial checks:

Environmental conditions

Check that:

- (1) The machine is placed on a flat, firm surface.
- (2) The machine is used in a clean environment at or near normal room temperature (10°C to 35°C) with normal relative humidity (20 to 80%).
- (3) The machine is not exposed to direct sunlight or harmful gases.

Power requirements

Check that:

- (1) The power supply specified on the rating plate on the machine is used. The supply voltage stays within the rating $\pm 10\%$.
- (2) Each voltage level on AC input lines and DC lines are correct.
- (3) All cables and harnesses are firmly connected.
- (4) None of the fuses are blown.

Recording paper

Check that:

- (1) A recommended type of recording paper is used.
- (2) The recording paper is not dampened.

Drum unit

- (1) The drum unit (including the toner cartridge) is installed correctly.

9.2.4 Troubleshooting Based on Problem Type

[1] Paper feeding problems

Even if the paper is printed and ejected without any problems such as paper jams, paper feeding problems below may appear.

Users can clear these problems by following the 'User Check' items for each problem. Even if the same problem occurs again, follow the procedures in the table below.

F-1	Double feeding
-----	----------------

 User Check Check the paper used meets the recommended paper specifications. (Refer to 2.1.2 "Paper Specifications" in Chapter 2.)

Possible cause	Step	Check	Result	Remedy
Separation pad	1	Is the surface of the separation pad worn out?	Yes	Replace the separation pad.

F-2	Wrinkles or creases
-----	---------------------

 User Check (1) Check that paper is loaded into the paper tray correctly. (2) Check the paper used meets the recommended paper specifications. (Refer to 2.1.2 "Paper Specifications" in Chapter 2.) (3) Try printing using the straight-through output path. (4) Turn over the stack of paper in the tray or try rotating the paper 180° in the tray.

Possible cause	Step	Check	Result	Remedy
Paper	1	Is the problem solved if new paper is used?	Yes	Instruct the user how to store paper so that it does not absorb moisture.
Fixing unit entrance guide	2	Is the entrance guide dirty?	Yes	Clean the entrance guide.
Fixing unit	3	Is the pressure roller dirty?	Yes	Clean the pressure roller.
			No	Replace the fixing unit.

F-3	Page skew
-----	-----------

✔ User Check

- (1) Check that the paper or other media is loaded into the paper tray correctly and that the paper guides are not too tight or too loose against the paper stack.
- (2) If using the manual feed slot, check how to load paper into the manual feed slot correctly.
- (3) The paper tray may be too full. Load paper below ▼ mark in depth.
- (4) Check the paper used meets the recommended paper specifications. (Refer to [2.1.2 “Paper Specifications” in Chapter 2.](#))

F-4	Curl or Wave
-----	--------------

✔ User Check

- (1) Check the paper used meets the recommended paper specifications. Both high temperature and humidity will cause paper to curl.
- (2) If the printer is used infrequently, the paper may have sat for too long in the paper tray. Turn over the stack of paper in the paper tray. Also, try rotating the paper 180° in the paper tray.
- (3) Check that the paper used meets the Media Type setting in the driver.

NOTE: For no paper supplied as the cause of a malfunction, see [M-4 ‘No paper supplied’ in 3. ‘MALFUNCTIONS’ in this Chapter.](#)

F-5	Paper pickup
-----	--------------

Possible cause	Step	Check	Result	Remedy
Disconnection of the pickup solenoid harness	1	Is the harness of the pickup solenoid disconnected?	Yes	Reconnect the harness.
Pickup solenoid harness failure	2	Does the harness of the pickup solenoid work correctly?	No	Replace the harness of the pickup solenoid.
Pressure plate gear damage	3	Is the pressure plate gear damaged?	Yes	Replace the pressure plate gear.
Clutch gear damage	4	Is the clutch gear damaged?	Yes	Replace the gear unit.

[2] Software setting problems

The printer may not print the data correctly if there are incorrect software settings.

S-1	“There was an error writing to LPT1: (or BRUSB) for the printer” error message appears.
-----	-----------------------------------------------------------------------------------------

<p> User Check</p> <p>(1) Check that the printer cable is not damaged or broken. Check also that the cable is connected to the correct interface connectors of both the printer and PC.</p> <p>(2) Check that the correct printer is selected if you have an interface switching device.</p> <p>(3) Check that the appropriate printer driver is selected as ‘Set as Default’. Check also that the correct print port is set for the selected printer driver.</p> <p>(4) Check that the printer is not connected to the same port which is also connected to a mass storage device or scanner. Remove all other devices and connect the port to the printer only. Turn off the printer status monitor in the device options tab in the printer driver.</p> <p>(5) If the print port is set as an ECP port, change it to a normal port.</p> <p>(6) Try printing the test page.</p> <p>(7) Try resetting the factory settings.</p>	
--------------------------------------------------------------------------------------------------------------------------------------------------------------------------------------------------------------------------------------------------------------------------------------------------------------------------------------------------------------------------------------------------------------------------------------------------------------------------------------------------------------------------------------------------------------------------------------------------------------------------------------------------------------------------------------------------------------------------------------------------------------------------------------------------------------------------------------------------------------------------------------------------------------------------------------------------------------------------------------------------------------------------	--

Possible cause	Step	Check	Result	Remedy
Failure inside the printer	1	Is it possible to print the test page with the method?	No	Identify the error type, then refer to the specified section of this chapter.
Main PCB failure	2	Is it possible to print with another PC and printer cable?	No	Replace the main PCB.
			Yes	This problem may appear under the specified system environment. Check the environment which the user used.

S-2	Although the USB driver is installed, it is unable to find the BRUSB: port. (Windows98/Me only)
-----	----------------------------------------------------------------------------------------------------

☑ User Check

(1) Re-install the USB driver by following the steps below;

- i) Turn the printer off.
- ii) Double-click the file “Deins USB.exe” in the USB directory of the CD-ROM.
- iii) Re-boot the PC.
- iv) Turn the printer on.
- v) “Add New Hardware Wizard” is launched again, follow the instructions in the Wizard to re-install the driver.

(2) Try to connect the printer directly to the computer if it is connected through a USB hub.

Possible cause	Step	Check	Result	Remedy
Computer Operating System	1	Windows 95 or Windows NT4.0?	Yes	The operating system does not support USB.
Computer settings	2	Does ‘Universal Serial Bus Controllers’ appear in the Device Manager tab of ‘System Properties’ in Control Panel?	No	This problem can be caused by your computer settings. See the computer manual.
USB cable/ printer damage	3	Does “Add New Hardware Wizard” appear on the screen or Does test print complete?	No	The USB cable is damaged. Replace the cable. If the same problem appears, the printer will be damaged.

S-3	This printer does not appear in Chooser (Mac OS [®] 9.1 to 9.2) or Print center (Mac OS [®] X 10.2.4 or greater).
-----	-------------------------------------------------------------------------------------------------------------------------------------

<p> User Check</p> <p>(1) Check the printer is turned on.</p> <p>(2) Check the USB cable is connected correctly.</p> <p>(3) Check the printer driver is installed correctly.</p>

Possible cause	Step	Check	Result	Remedy
Printer connection	1	Select 'Apple System Profiler' in Apple Menu. Are the following items indicated in the USB box of the Device and Volumes tab? <ul style="list-style-type: none"> • Product ID: 0180 (for MFC7420) 0181 (for MFC7820N) 0182 (for DCP7010) 0183 (for DCP7020) 0184 (for DCP7025) Vender: Brother International Corporation (or 0x4f9) 	No	Check the printer is turned on and the USB cable is connected correctly. Check that the USB cable used is the shielded twisted pair type and 5 m or less. Try to connect the printer and PC with the USB cable directly.
Driver installation	2	Are there the following files in the Extensions Folder of System Folder? <For System 9.1 – 9.2> <ul style="list-style-type: none"> • BR_PrintMonitor (laser) • Brother Laser 	No	Try to re-install the printer driver.
			Yes	Turn off the printer and PC power switch, and check all connections between them. Then, turn them on again.

S-4	Make sure that the supplied Macintosh [®] printer driver is installed in the Hard Disk and that it is selected with Chooser (Mac OS [®] 9.1 to 9.2) or Print Center (Mac OS [®] X 10.2.4 or greater).
-----	----------------------------------------------------------------------------------------------------------------------------------------------------------------------------------------------------------------------------------

[3] Malfunction

When taking countermeasures for malfunctions as described in this section, check connectors for contact failure before measuring the voltage at the specified connector pins.

M-1	No AC power supplied
-----	----------------------

Possible cause	Step	Check	Result	Remedy
Supply voltage	1	Is the correct voltage present at the outlet?	No	Inform the user that the correct voltage is not supplied at the outlet.
Power plug	2	Is the power cord securely plugged into the outlet?	No	Plug the power cord securely into the outlet.
Fuse (F1, F2)	3	Is the fuse blown?	Yes	If the fuse blows again immediately after replacing the low-voltage power supply PCB, check that there is not a short circuit somewhere in the AC power supply line.
Wiring	4	Unplug the power supply plug. Is there a broken wire between the AC input connector of the low-voltage power supply and the power plug?	Yes	Replace the AC power cord.

M-2	No DC power supplied
-----	----------------------

Possible cause	Step	Check	Result	Remedy
AC power supply	1	Is AC power supplied between connectors CN1-L and CN1-N when the power plug is plugged into the outlet?	No	Follow the same check procedure of M-1 “No AC power supplied”.
Wiring, DC load	2	Turn on the power switch. Measure the voltages between the terminals. Do the measured voltage satisfy the prescribed valued in the table below?	Yes	Turn off the power switch, reconnect the connector and turn the power switch on again. If the protector circuit is activated, check the connector, the wiring from the connector, and the DC load.
Low-voltage power supply PCB	3	Refer to the chart * 1 below.	No	Replace the low-voltage power supply PCB.

*1

PCB	+lead pin	- lead pin	Voltage
Main	CN12-6	CN12-9	Approx. 24V
	CN12-8	CN12-9	Approx. 5V

WARNING: If you analyze malfunctions with the power plug inserted into the power outlet, special caution should be exercised even if the power switch is OFF because it is a single pole switch

M-3	Main motor failure
-----	--------------------

Possible cause	Step	Check	Result	Remedy
Failure of connector	1	Is the connection of connector CN9 on the main PCB correct?	No	Reconnect the connector.
Main motor	2	Is the problem solved by replacing the main motor?	Yes	Replace the main motor.
Main PCB	3	Is the problem solved by replacing the main PCB?	Yes	Replace the main PCB.

M-4	No paper supplied
-----	-------------------

Possible cause	Step	Check	Result	Remedy
Separation pad / pickup roller failure	1	Is the surface of the separation pad or the pickup roller dirty or worn out?	Yes	1) Clean the surface of the separation pad or pickup roller. 2) Replace the separation pad or pickup roller.
Failure of connector	2	Is the contact of the solenoid connector on the high voltage PCB good?	No	Reconnect the connector.
HVPS circuit	3	Set paper in the manual feed slot and make a test print. Does the voltage between pins 2 (SOLENOID) and 1 (24V) of the CN16 connector on the main PCB change from approx. 24V DC to 0V within the specified time?	Yes	Replace the HVPS.
Paper pickup clutch solenoid			No	Replace the paper pickup clutch solenoid.
Main PCB	4	Is the problem solved by replacing the main PCB?	Yes	Replace the main PCB.

M-5	Insufficient output from high-voltage power supply unit
-----	---------------------------------------------------------

Possible cause	Step	Check	Result	Remedy
High-voltage contact	1	Do any of the terminals on the high-voltage contacts have dirt or contact burns?	Yes	Clean the terminals.
High-voltage power supply PCB	2	Check the connections of the connector between the high-voltage power supply and the main PCB are secured correctly?	Yes	Replace the high-voltage power supply PCB.
			No	Reconnect the connector between the high-voltage power supply and the main PCB.

M-6	Fixing heater temperature failure
-----	-----------------------------------

Possible cause	Step	Check	Result	Remedy
Poor thermistor harness contact	1	Is the contact of connector CN19 on the main PCB good?	No	Reconnect the connector.
Blown thermal fuse	2	Remove the fixing unit and measure the resistance of the thermal fuse. Is it open circuit?	Yes	Replace the fixing unit.
Blown thermostat	3	Remove the fixing unit and measure the resistance of the thermostat. Is it open circuit?	Yes	Replace the fixing unit.
Halogen heater lamp failure	4	Remove the fixing unit and measure the resistance of the halogen heater lamp. Is it open circuit?	Yes	Replace the halogen heater lamp.

M-7	Laser Unit failure
-----	--------------------

Possible cause	Step	Check	Result	Remedy
Harness connection failure (1)	1	Is connector CN6 on the main PCB secured correctly?	No	Reconnect the connector securely.
			Yes	Replace the laser unit.
Harness connection failure (2)	2	Is the connection of the scanner motor connector CN6 on the main PCB secure?	No	Reconnect the connector securely.
			Yes	Replace the laser unit.

M-8	Fixing unit failure
-----	---------------------

Possible cause	Step	Check	Result	Remedy
Poor thermistor harness contact	1	Is the contact of connector CN19 on the main PCB good?	No	Reconnect the connector.
Blown thermal fuse	2	Remove the fixing unit and measure the resistance between the thermostat. Is it open circuit?	Yes	Replace the fixing unit.
Thermistor assembling failure	3	Is the thermistor installed properly?	Yes	Replace the fixing unit.
			No	Reinstall the thermistor properly.
Halogen heater lamp failure	4	Remove the fixing unit and measure the resistance of the halogen heater lamp. Is it open circuit?	Yes	Replace the halogen heater lamp.
Heater harness connection failure	5	Is the heater harness connector connected to the low-voltage power supply PCB and fixing unit secure?	No	Reconnect the connectors securely.

NOTE:

- This problem will be cleared if leaving the printer power ON for ten minutes.

M-9	Main PCB failure
-----	------------------

Possible cause	Step	Check	Result	Remedy
Main PCB	1	Is it possible to print the test page with the method?	No	Replace the main PCB.
Software bug	2	Does this problem appear when printing specific data or printing under a specific environment?	Yes	Inform the Brother office of the used specific data, printer condition and system environment.

M-10	Pickup function of paper tray does not work.
------	----------------------------------------------

Possible cause	Step	Check	Result	Remedy
Link lever does not move smoothly.	1	Does the link lever work? Isn't the link lever bent?	Yes	Remove the cause of non-smooth operation of the link lever. Replace the link lever.
Pickup roller holder ASSY does not move smoothly.	2	Does the pickup roller holder ASSY move up and down?	No	Replace the pickup roller holder ASSY.
Main motor failure	3	Does the main motor work?	No	Replace the main motor.
Pressure plate drive cam failure	4	Does the pressure plate drive cam rotate?	No	Replace the main frame L ASSY.

M-11	The new toner is not sensed.
------	------------------------------

Possible cause	Step	Check	Result	Remedy
The toner cartridge is not set to the main body correctly	1	The toner cartridge is not inserted completely.	Yes	Reset the cartridge.
New toner detection switch failure	2	Isn't the toner sensed even if the switch is held?	Yes	Replace the switch.
Main PCB failure	3	Is the problem solved by replacing the main PCB?	No	Replace the main PCB.

M-12	Maximum speed is slow.
------	------------------------

Possible cause	Step	Check	Result	Remedy
Two or more sheets of the paper in the tray are pulled to feed.	1	Does paper double feeding occur?	Yes	Replace the separation pad.
Foreign body attached to the tail edge actuator	2	Is a foreign body caught on the tail edge actuator?	Yes	Remove a foreign body.
Tail edge actuator failure	3	Is the tail edge actuator deformed?	Yes	Replace the tail edge actuator.
Tail edge sensor malfunction	4	Is the tail edge sensor turned ON?	Yes	Replace the tail edge sensor.

M-13	Error indication when turning the power ON
------	--------------------------------------------

Possible cause	Step	Check	Result	Remedy
Disconnection of the main motor harness	1	Is the harness of the main motor connected?	No	Reconnect the harness securely.
Disconnection of the scanner motor harness	2	Is the harness of the scanner motor connected?	No	Reconnect the harness securely.
Fixing unit failure	3	Does the printer resume after opening the cover, turning the power ON and leaving the printer for ten minutes?	No	Replace the thermistor.

M-14	The printer stops while idling.
------	---------------------------------

Possible cause	Step	Check	Result	Remedy
Front cover failure	1	Is the cover opened by vibration during idling?	Yes	Replace the front cover.
New toner detection switch failure	2	Does the new toner detection switch work correctly?	No	Replace the new toner detection switch.
Process unit terminal failure	3	Are the terminals of the process unit dirty?	Yes	Clean the terminals.
Laser unit failure	4	Does the laser unit work correctly?	No	Replace the laser unit.

[4] Image defects



1-1 Light



1-2 Dark

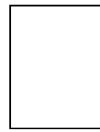

1-3 Completely blank



1-4 All black



1-5 Dirt on the back of paper



1-6 Black vertical streaks



1-6 Black vertical streaks



1-7 Black horizontal stripes

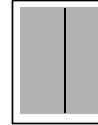

1-8 Black vertical streaks



1-9 White vertical streaks



1-10 White horizontal streaks

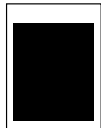

1-11 Faulty registration

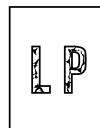

1-12 Poor fixing

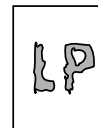

1-13 Image distortion



1-14 Faint print

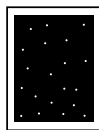

1-15 White spots



1-16 Black spots



1-17 Black band



1-18 Gray background

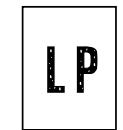

1-19 Hollow print



1-20 Downward fogging of solid black

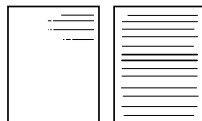

1-21 Horizontal lines

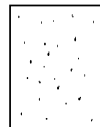

1-22 Light rain



1-23 Ghost

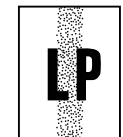

1-24 Toner specks

I-1	Light
-----	-------

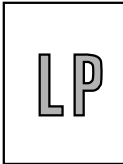

User Check

- (1) Check the printer's environment. Conditions such as humidity, high temperatures, etc. may cause this situation to occur.
- (2) If the whole page is light, toner save mode may be on. Disable toner save mode within Printer Properties tab of the driver.
- (3) Try installing a new toner cartridge or drum unit.

Possible cause	Step	Check	Result	Remedy	Ground contacts
Toner sensor failure (printer side)	1	Can printing be started with the drum unit and toner cartridge removed?	Yes	Check if the toner sensor is dirty and check the toner sensor connection.	
Toner sensor failure (toner cartridge side)	2	Is the problem solved when 4 or 5 pages are printed after the toner cartridge is replaced with a full one?	Yes	The wiper of the toner cartridge is defective. Replace the toner cartridge.	
Drum connection failure	3	Are all the contacts between the drum unit and printer body connected correctly?	No	Clean contact electrodes both on the drum unit and in the printer body.	(1), (4) (5), (6)
HVPS / Main PCB failure	4	Is the harness connection between the HVPS and the main PCB correct?	Yes	Replace the HVPS or the main PCB.	
Dirt on the scanner window	5	Is there any dirt on the scanner window?	Yes	Wipe it off with a soft clean paper.	
Laser unit failure	6	Is the problem solved after replacing the laser unit?	Yes	Replace the laser unit.	

I-2	Dark
-----	------



User Check

- (1) Check the paper used meets the recommended paper specifications.
- (2) Check the printer's environment. High temperature and high humidity conditions can increase the amount of background shading.
- (3) Clean the corona wire with the wire cleaner.
- (4) Try installing a new toner cartridge or drum unit.

Possible cause	Step	Check	Result	Remedy	Ground contacts
Corona failure (contact failure)	1	Are the charge electrodes between the printer body and the drum unit dirty?	Yes	Clean both electrodes.	(3)
Drum unit failure	2	Is the problem solved after replacing the drum unit?	Yes	Replace the drum unit with a new one.	
Toner cartridge failure	3	Is the problem solved after replacing the toner cartridge?	Yes	Replace the toner cartridge with a new one.	
High-voltage power supply PCB failure	4	Is the connections of the connector between the high-voltage power supply PCB and the main PCB secured correctly?	Yes	Replace the high-voltage power supply PCB.	
Main PCB failure	5	Are there any disconnected connectors?	No	Replace the main PCB.	

I-3	Completely blank
-----	------------------

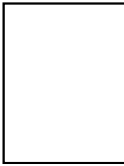

Possible cause	Step	Check	Result	Remedy	Ground contacts
Developing bias contact failure	1	Are the developing bias contacts between the printer body and drum unit dirty?	Yes	Clean the electrodes at both sides.	(4)
Drum unit	2	Are the drum shaft and drum electrode of the printer body connected correctly?	Yes	Clean the shaft and the electrode.	(1)
			No	Check the connection between the shaft and the electrode.	(1)
Drum unit failure	3	Is the problem solved after replacing the drum unit?	Yes	Replace the drum unit.	
Toner cartridge failure	4	Is the problem solved after replacing the toner cartridge?	Yes	Replace the toner cartridge with a new one.	
Scanner harness connection failure	5	Is the scanner harness connected securely? (Check if there is any play in the connection.)	No	Reconnect the connector correctly.	
Main PCB failure	6	Are printing signals being input to the laser unit? Is the problem solved after replacing the main PCB?	Yes	Replace the main PCB.	
Laser unit failure	7	Is the scanner interlock lever damaged?	Yes	Replace the laser unit.	
			No	Replace the high-voltage power supply PCB.	

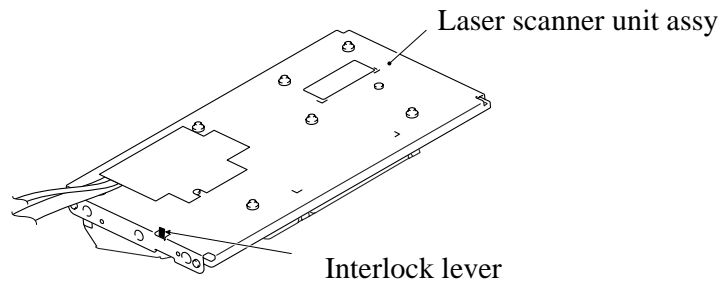

I-4	All black
-----	-----------



User Check

- (1) Clean the corona wire of the drum unit.
- (2) The drum unit may be damaged. Install a new drum unit.

Possible cause	Step	Check	Result	Remedy	Ground contacts
Corona failure	1	Is the corona wire dirty?	Yes	Clean the corona wire with the wire cleaner.	(2)
	2	Is the corona wire broken?	Yes	Replace the drum unit.	
	3	Are the charge electrodes between the printer body and the drum unit dirty?	Yes	Clean both electrodes.	(3)
Harness connection	4	Is the laser unit connected to the main PCB correctly?	No	Connect the harness between the laser unit and the main PCB correctly.	
High-voltage power supply PCB failure	5	Is the problem solved after replacing the high-voltage power supply PCB?	Yes	Replace the high-voltage power supply PCB.	
Main PCB failure	6	Is the problem solved after replacing the main PCB?	Yes	Replace the main PCB.	
Laser unit failure	7	Is the problem solved after replacing the laser unit?	Yes	Replace the laser unit.	

I-5	Dirt on the back of paper
-----	---------------------------

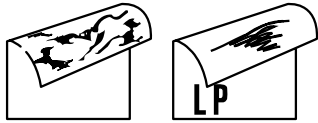

Possible cause	Step	Check	Result	Remedy
Fixing unit dirty	1	Is the pressure roller dirty? Is any other area in the printer dirty?	Yes	Clean the pressure roller referring to the following procedure.
Dirt in the drum unit	2	Is the transfer roller dirty? Is the problem solved after replacing the drum unit?	Yes	Replace the drum unit
			No	Replace the high-voltage power supply PCB.

NOTE: This problem may disappear after printing approximately 10 pages of completely blank sheets.

How to clean the pressure roller

Clean the pressure roller as follows;

- (1) Set 5 or more sheets of paper in the paper tray.
- (2) Press the **Menu/Set (Menu)**, **Start**, **▲**, **▲**, **▲**, **▲** keys in this order so that the machine goes into the maintenance mode.
- (3) MFC7420/7820N
Press the **6** and **7** keys.
DCP7010/7020/7025
Enter **6** and **7** by using the **▲** and **Set** keys.
The machine starts to print the grid pattern continuously.
- (4) When five pages are printed, press the **Stop** key. The machine returns to the initial stage of the maintenance mode.
- (5) MFC7420/7820N
Press the **9** key twice so that the machine returns to the ready status.
DCP7010/7020/7025
Enter **9** twice by using the **▲** and **Set** keys so that the machine returns to the ready status.

I-6	Black and blurred vertical streaks
-----	------------------------------------

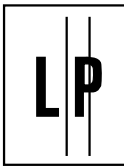

User Check

- (1) Clean the corona wire in the drum unit.
- (2) Check that the wire cleaner is at the home position.
- (3) Check that the toner cartridge is not empty.
- (4) The drum unit may be damaged. Install a new drum unit.
- (5) The toner cartridge may be damaged. Install a new toner cartridge.

Possible cause	Step	Check	Result	Remedy
Corona failure	1	Is the vertical block streak about 10mm wide? (Check if the wire cleaner is at its home position.)	Yes	Return the wire cleaner to its home position.
Dirt in the paper feed system	2	Is the paper tray or feed system on the drum unit dirty with toner?	Yes	Clean the toner off.
Scratch on the drum	3	Is the drum surface scratched?	Yes	Replace the drum unit.
Cleaning failure	4	Is the drum surface dirty with toner in streaks?	Yes	Replace the drum unit.
Scratch on the heat roller	5	Is the surface of the heat roller scratched?	Yes	Replace the fixing unit.

NOTE:

- If you print the same pattern (especially vertical streaks) continuously, electrostatic charge performance of the drum will decrease temporarily and black vertical streaks may appear on the paper
- This problem may occur with noise due to the corona wire being dirty. In that case, clean the corona wire with the wire cleaner.

I-7	Black and blurred horizontal stripes
-----	--------------------------------------



User Check

- (1) The drum unit may be damaged. Install a new drum unit.
- (2) Check the paper used meets the recommended paper specifications.
- (3) Clean the printer interior and the corona wire in the drum unit.

Possible cause	Step	Check	Result	Remedy	Ground contacts
Scratch on the drum	1	Are the horizontal stripes at 74mm (exposure drum) intervals?	Yes	The exposure drum was scratched. Replace the drum unit.	
Toner stuck on the developer roller	2	Are the horizontal stripes at 37mm (developer roller) intervals?	Yes	After printing several pages, the problem will disappear. If not, replace the toner cartridge.	
Scratch on the heat roller	3	Are the horizontal stripes at 79mm (heat roller) intervals?	Yes	Replace the heat roller.	
Corona contact failure	4	Are the charge electrodes between the printer body and the drum unit dirty?	Yes	Clean both electrodes.	(3)
High-voltage power supply PCB failure	5	Is the problem solved after replacing the high-voltage power supply PCB?	Yes	Replace the high-voltage power supply PCB.	

I-8	Black vertical streaks (in a gray background)
-----	-----------------------------------------------

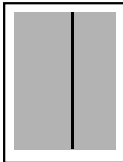

Possible cause	Step	Check	Result	Remedy	Ground contacts
Translucent stain on the scanner window	1	Is there any dirt on the scanner window?	Yes	1) Clean the scanner window. 2) If it is not effective, replace the laser unit.	
Corona failure	2	Is the corona wire dirty?	Yes	Clean the corona wire with the wire cleaner.	(2)

I-9	White vertical streaks
-----	------------------------



User Check

- (1) Try to wipe the scanner window with a soft cloth.
- (2) The toner cartridge may be damaged. Install a new toner cartridge.
- (3) Check the printer's environment. High temperature and high humidity conditions can cause this problem.
- (4) Damp (wet) paper might be used. Try to change to freshly unpacked paper.

Possible cause	Step	Check	Result	Remedy
Transfer failure	1	Is the transfer roller scratched?	Yes	Replace the drum unit.
Condensation	2	Has condensation occurred inside the printer?	Yes	Try to print several pages or leave the printer 2 hours to allow it to reach room temperature.

I-10	White horizontal streaks
------	--------------------------

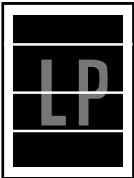

User Check

- (1) Check the paper used meets the recommended paper specifications. A rough surfaced paper, damp paper or thick media can cause the problem.
- (2) Check that the appropriate media type is selected in the printer driver.
- (3) The problem may disappear by itself. Try printing multiple pages to clear this problem especially if the printer has not been used for a long time.
- (4) The drum unit may be damaged. Install a new drum unit.

Possible cause	Step	Check	Result	Remedy	Ground contacts
Developing bias contact failure	1	Are the developing bias contacts between the printer body and toner cartridge dirty?	Yes	Clean the electrodes at both sides.	(4)

I-11	Faulty registration
------	---------------------

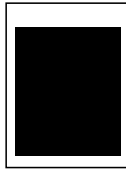

Possible cause	Step	Check	Result	Remedy
Excessive paper load	1	Is the paper loaded in the paper tray more than 27mm high?	Yes	Instruct the user to keep paper loads below 27mm in depth.
Print paper	2	Is the specified weight of the recommended paper being used?	No	Recommend to use the specified types of paper.
	3	Is the first printing position within ± 1 mm of the tolerance specification?	Yes	Adjust the Y offset by using the utility software supplied.
Regist rear sensor position incorrect	4	Is the regist rear sensor off from the correct position?	Yes	Reposition the sensor to the correct position.
Drum unit failure	5	Is the rotation torque of the drum unit heavy?	Yes	Replace the drum unit.

I-12	Poor fixing
------	-------------

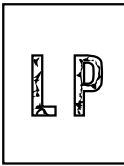

Possible cause	Step	Check	Result	Remedy
Print paper	1	Is thick paper of more than 43lb being used?	Yes	Recommend to use the specified types of paper.
Toner sensor failure (When printing is faint.)	2	Is the problem solved by replacing the drum unit or the toner cartridge?	Yes	1) Toner is empty. 2) The toner sensor is defective. Clean the toner sensor. 3) If the wiper in the toner cartridge is broken, replace the toner cartridge with a new one.
Fixing unit thermistor failure	3	Is the thermistor fitted correctly?	No	Fit the thermistor correctly.
Low-voltage power supply PCB failure	4	Is the problem solved by replacing the low-voltage power supply PCB?	Yes	Replace the low-voltage power supply PCB.

I-13	Image distortion
------	------------------

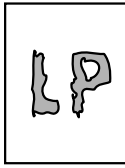

Possible cause	Step	Check	Result	Remedy
Laser unit installation	1	Is the laser unit secured to the frame incorrectly? (Check if there is any play.)	No	Secure the unit correctly and tighten the screws.
Scanner LD emission failure Scanner motor rotation failure	2	Is the laser diode or the scanner motor defective?	No	Replace the laser unit.
Scanner connection failure	3	Is the scanner harness connected properly? (Check if it is coming loose.)	No	Connect the harness correctly.

I-14	Faint print
------	-------------

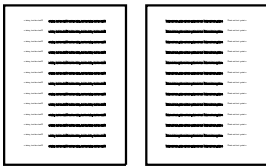

Possible cause	Step	Check	Result	Remedy
Printer installation	1	Is the printer placed horizontally?	No	Place the printer on a flat surface.
Toner cartridge	2	Does the problem happen immediately after replacing the toner cartridge with a new one?	Yes	Remove and carefully shake the toner cartridge horizontally.
Scanner window dirty	3	Is the scanner window dirty?	Yes	Clean the scanner window with a soft dry cloth.
Laser unit failure	4	Is the problem solved by replacing the laser unit?	Yes	Replace the laser unit.

I-15	White spots
------	-------------

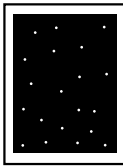

User Check

- (1) If the problem is not solved after printing a few pages, the drum unit may have glue from label stock on the exposure drum surface. Refer to Step 1 in the table below and **NOTE** in the next page.
- (2) The drum unit may be damaged. Install a new drum unit.

Possible cause	Step	Check	Result	Remedy
Drum unit failure	1	Are the white spot at 74mm intervals?	Yes	1) If toner or glue remains stuck, wipe it off gently with a cotton swab. (Refer to NOTE in the next page.) 2) If the drum surface is scratched, replace the drum unit.
	2	Is the problem solved after replacing the drum unit?	Yes	Replace the drum unit.
No toner	3	Is the toner in the toner cartridge almost empty?	Yes	Replace the toner cartridge with a new one.
Print paper	4	Is the problem solved after changing to specified freshly unpacked paper?	No	Damp (wet) paper might be used. Recommend to change freshly unpacked paper.
Environment	5	Does the problem still appear after the printer has warmed up?	Yes	1) Replace the drum unit. 2) Advise the user of the specified print environment

NOTE: Clean the drum unit as follows.

- (1) Remove the toner cartridge from the drum unit. Place the printing samples in front of the drum unit, and find the exact position of the image defect.

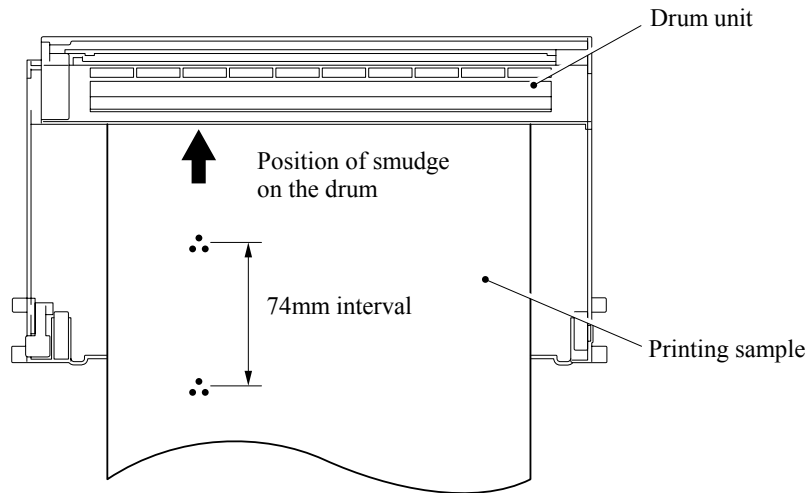

- (2) Turn the drum gear by hand while looking at the surface of the exposure drum.

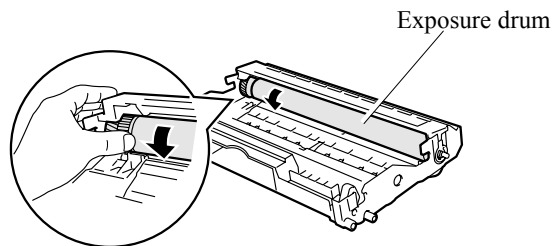

- (3) Wipe the surface of the exposure drum with a cotton swab until the dust or paper powder on the surface comes off.

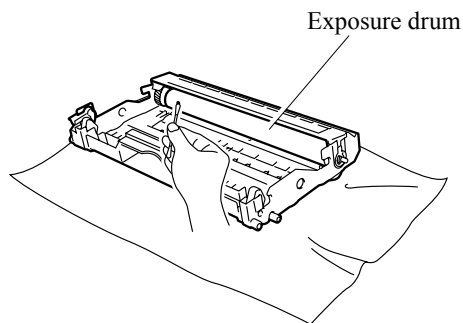

CAUTION:

- Do not wipe the surface of the exposure drum with something sharp. (ball-point pen etc.)
- Use cleaning liquid which is a 50-50 mixture of ethyl alcohol and pure water.

I-16	Black spots
------	-------------



User Check

- (1) If the problem is not solved after printing a few pages, the drum unit may have glue from label stock on the exposure drum surface. Refer to Step 1 in the table below and **NOTE** in the next page.
- (2) The drum unit may be damaged. Install a new drum unit.

Possible cause	Step	Check	Result	Remedy	Ground contacts
Drum unit	1	Are the spots at 74mm intervals? (The problem is not solved after printing a few pages.)	Yes	1) If toner or glue remains stuck, wipe it off gently with a cotton swab. (Refer to NOTE in the previous page.) 2) If the exposure drum is scratched or deteriorated (exposed), replace the drum unit.	
Drum connection failure	2	Is the contact between the drum unit and printer body connected correctly?	No	Clean contact electrode both on the drum unit and in the printer body.	(7)
Fixing unit	3	Are the spots at 79mm intervals? (The problem is not solved after printing a few pages.)	Yes	1) Check and clean the heat roller with a cloth dampened with alcohol. 2) Replace the fixing unit.	
High-voltage power supply PCB failure	4	Is the problem solved after replacing the high-voltage power supply PCB?	Yes	Replace the high-voltage power supply PCB.	

I-17	Black band
------	------------



Possible cause	Step	Check	Result	Remedy	Ground contacts
Corona failure	1	Is the wire cleaner at its home position?	No	Return the wire cleaner to its home position.	(2)
Corona dirty	2	Is the corona wire dirty?	Yes	1) Clean the corona wire. 2) If the problem still appears after cleaning, replace the drum unit.	(2)

I-18	Gray background
------	-----------------



Possible cause	Step	Check	Result	Remedy
Print paper	1	Does the paper being used meet the paper specification (weight, etc.)	No	Recommend to use the specified types of paper.
			Yes	Recommend to change to freshly unpacked paper.
Toner sensor failure (printer side)	2	Is the error indication displayed when the toner cartridge and drum unit is taken out of the machine? (The front cover is closed.)	No	Toner sensor failure. Clean the toner sensor and check the toner sensor connection.
Toner cartridge failure	3	Is the problem solved after replacing the toner cartridge?	Yes	Replace the toner cartridge.
Drum unit failure	4	Is the problem solved after replacing the drum unit?	Yes	Replace the drum unit.
			No	Replace the high-voltage power supply PCB.

NOTE: The following cases increase the possibility of this problem.

- Acid paper is being used.
- The drum unit is at the end of its life.
- There is dust or paper powder.

I-19	Hollow print
------	--------------



User Check

- (1) Check the paper used meets the recommended paper specifications.
- (2) Select the 'Thick paper mode' in the printer driver, or use thinner paper than you are currently using.
- (3) Check the printer's environment, conditions such as high humidity may cause this situation to occur.

Possible cause	Step	Check	Result	Remedy
Print paper	1	Is thick paper of more than 43lb being used or extremely rough surface paper?	Yes	Recommend to use the specified types of paper.
			No	Refer and compare with [4] Image defect I-15 .

I-20	Downward fogging of solid black
------	---------------------------------



Possible cause	Step	Check	Result	Remedy
Toner cartridge failure	1	Is the problem solved after replacing the toner cartridge?	Yes	Replace the toner cartridge.
High-voltage power supply PCB failure	2	Is the problem solved after replacing the high-voltage power supply PCB?	Yes	Replace the high-voltage power supply PCB.

I-21	Horizontal lines
------	------------------

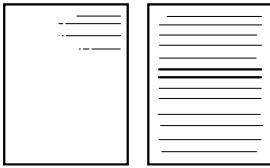

Possible cause	Step	Check	Result	Remedy
Paper tray contacts	1	Are the ground contacts on the right side of the paper tray connecting correctly?	No	Clean the contacts.
Drum unit	2	Are the high-voltage power supply and drum unit contacted correctly?	No	Clean the contacts.

I-22	Light rain
------	------------

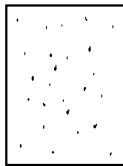

Possible cause	Step	Check	Result	Remedy	Ground contacts
Drum unit failure	1	Is the problem solved after replacing the drum unit?	Yes	Replace the drum unit.	
Drum connection failure	2	Is the contact between the drum unit and printer body connected correctly?	No	Clean contact electrode both on the drum unit and in the printer body.	(7)
High-voltage power supply PCB failure	3	Is the problem solved after replacing the high-voltage power supply PCB?	Yes	Replace the high-voltage power supply PCB.	

I-23	Ghost
------	-------



User Check

- (1) Check the paper used meets the recommended paper specifications. Damp paper, thick media or rough surfaced paper can cause the problem.
- (2) Check the printer's environment. High temperature and high humidity conditions can cause the problem.
- (3) Check that the appropriate media type is selected in the printer driver.
- (4) Try installing a new drum unit.

Possible cause	Step	Check	Result	Remedy
Driver setting	1	Is thin paper such as 64g/m ² used under the thick paper mode?	Yes	1) Change the current mode to the normal mode from the driver setting. 2) Print 5 or 6 blank pages if this problem occurs.
Drum unit failure	2	Is the problem solved after replacing the drum unit?	Yes	Replace the drum unit.
High-voltage power supply PCB failure	3	Is the problem solved after replacing the high-voltage power supply PCB?	Yes	Replace the high-voltage power supply PCB.

I-24	Toner specks
------	--------------

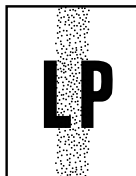

User Check

- (1) Check the paper used meets the recommended paper specifications. A rough surfaced paper may cause the problem.
- (2) The toner cartridge may be damaged. Install a new toner cartridge.
- (3) The drum unit may be damaged, or may be nearly at the end of life. Install a new drum unit.

■ Location of Grounding Contacts

• Drum unit

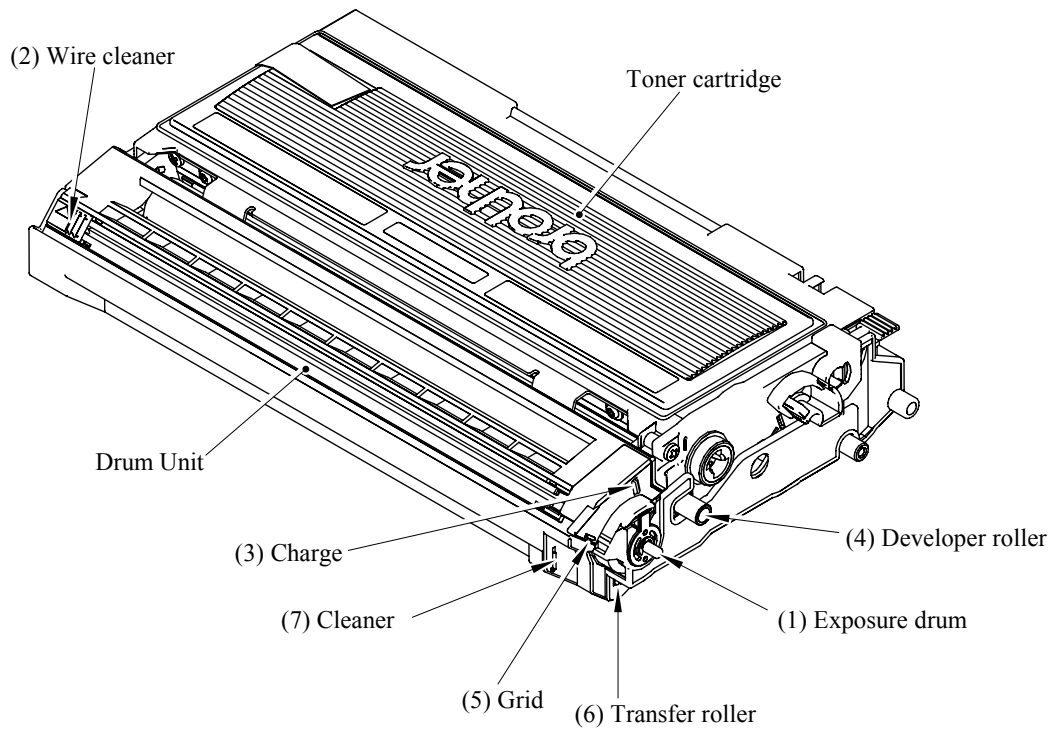

• Printer body & paper tray

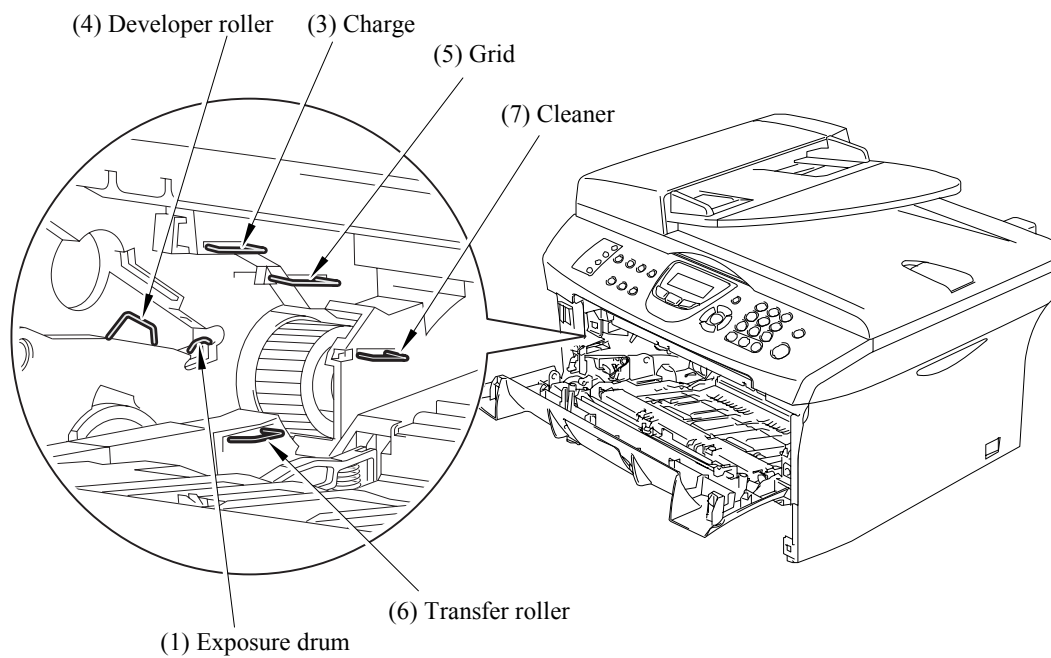

[5] Incorrect printout

When the data is not printed correctly as it is seen on the PC screen, follow the procedures below in the event of a specific error.

P-1	The printer prints unexpectedly or it prints garbage.
-----	-------------------------------------------------------

 **User Check**

- (1) Check if the printer cable is not too long. It is recommended to use a parallel cable of less than 2 meters (6.6 feet) in length.
- (2) Check that the printer cable is not damaged or broken. Check also that the printer cable is connected to the correct interface connectors of both the printer and PC.
- (3) If an interface switching device is used, remove it and connect the computer directly to the printer and try again.
- (4) Check that the appropriate printer driver is selected as 'Set as Default'. Check also that the correct print port is set for the selected printer driver.
- (5) Check that the printer is not connected to the same port which is also connected to a mass storage device or scanner. Remove all other devices and connect the port to the printer only. Turn off the printer status monitor in the device options tab in the printer driver.
- (6) If the print port is set as an ECP port, change it to a normal port.
- (7) Try printing the test page.
- (8) Try resetting the factory settings.

Possible cause	Step	Check	Result	Remedy
Failure inside the printer	1	Is it possible to print the test?	No	Identify the error type, and then refer to the specified section of this chapter.

NOTE: If the printer prints garbage or incorrect fonts, instruct the user to use the 'Troubleshooting for Printer won't print' tool of the self-diagnostics tools. If the problem cannot be solved, instruct user to use the 'Diagnostics' tool described in the Chapter 7 so that you can get a log file to investigate the cause of the problem.

P-2	Unable to print full pages of a document with the "PRINT OVERRUN" message.
-----	----------------------------------------------------------------------------

 **User Check**

- (1) Press the **Start** key on the control panel to print the data remaining in the printer.
- (2) If this does not clear the error, reduce the complexity of your document or reduce the printer resolution.
- (3) Change the following setting in the printer driver and try again. The best combination of settings below will vary depending on your document.
Graphic Mode / TrueType™ mode

NOTE: This problem may appear if the data is too complex. If it is not cleared by taking the actions above, it will be impossible to print such data under the printer specifications.

P-3	Unable to print full pages of a document with the “MEMORY FULL” message.
-----	--------------------------------------------------------------------------

 **User Check**

(1) Press the **Start** key on the control panel to print the data remaining in the printer.
(2) Reduce the complexity of your document or reduce the printer resolution.

NOTE: This problem may appear if the data is too complex.

Possible cause	Step	Check	Result	Remedy
Main PCB failure	1	Is it possible to print after reducing the data of a document?	Yes	Replace the main PCB.

P-4	Headers or footers are not printed out even though they are viewed on PC screen.
-----	----------------------------------------------------------------------------------

 **User Check**

Most laser printers have a restricted area that cannot be printed on. Usually the first two lines and last two lines of text cannot print (leaving 62 printable lines). Adjust the top and bottom margins in your document to allow for this.

P-5	The printer sometimes prints a couple of characters and then ejects the page.
-----	-------------------------------------------------------------------------------

 **User Check**

(For DOS environment only)

The application printer emulation setting and the printer’s emulation do not match. Check in the application software which printer you have selected to make sure the printer is set up correctly. Remember that the printer emulates widely used printer selections:

HP Laser Jet 6P, HP Laser Jet 6P, Epson FX-850, IBM Proprinter XL

Try setting the printer into HP emulation and then select the HP LaserJet 6P printer in the application software.

[6] Network problem

If the error related to network occurs, refer to the following sections;

■ Installation problem

The Brother print server is not found during setup of the network print software installation or from the printer driver of the Brother printer in Windows®.

The Brother print server is not found using the Simple Network Configuration capabilities of Mac OS® X.

Make sure you have completed the IP address setting of the Brother print server according to Chapter 2 of this User's Guide before installing the network print software or printer driver. Check the following:

1. Make sure that the printer is powered on, is on-line and ready to print.
2. Check to see if there is any LED activity. Brother print servers have two LEDs on the back panel of the printer. The upper side LED shows Link status. The lower side LED shows Activity (Receive/Transmit) status.
No light: If both LEDs are off, then the print server is not connected to the network.
Link LED is green: The Link LED indicates green if the print server is connected to a Ethernet network.
3. Print the Printer Settings Page and check if the settings such as IP address settings are correct for your network. The problem may be the result of mismatched or duplicate IP address. Verify that the IP address is correctly loaded into the print server. And make sure that no other nodes on the network have this IP address.
4. Verify that the print server is on your network as follows:

For Windows®

Try pinging the print server from the host operating system command prompt with the command:

```
ping ipaddress
```

Where ipaddress is the print server IP address (note that in some instances it can take up to two minutes for the print server to load its IP address after setting the IP address).

For Macintosh®

For Mac OS® 9.1 to 9.2

- (1) From the **Apple** menu, open the **Chooser**.
- (2) Click the **Brother Laser (IP)** icon, and make sure that your print server name appears in the right frame. If it is visible, then the connection is good. Otherwise, go to Step 5.

For Mac OS® X 10.2.4 or greater

- (1) From the **Go** menu, select **Applications**.
- (2) Open the **Utilities** folder.
- (3) Double-click the **Printer Setup Utility** icon.
- (4) Click **Add**.

- (5) Make the following selection. Make sure that your print server appears. If it is visible, then the connection is good. Otherwise, go to Step 5.

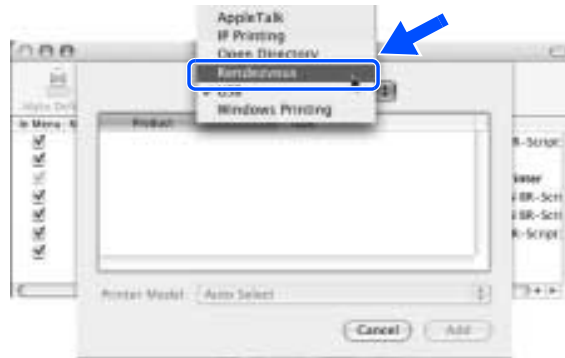

5. If you have tried 1 to 4 above and it does not work, then reset the print server back to the default factory settings and try from the initial setup again. For information how to reset to the default factory settings.
6. Check if a personal firewall such as ICF (Internet Connecting Firewall) for Windows XP is running on your computer. If it is running, temporarily turn it off and try again.

NOTE: If none of the above steps are successful, there is almost certainly a hardware or network problem.

■ Printing problem

<Print job is not printed>

Make sure the status and configuration of the print server. Check following:

1. Make sure that the printer is powered on, is on-line and ready to print.
2. Print the Printer Settings Page of the printer and check if the settings such as IP address settings are correct for your network. The problem may be the result of mismatched or duplicate IP address. Verify that the IP address is correctly loaded into the print server. And make sure that no other nodes on the network have this IP address.
3. Verify that the print server is on your network as follows:

For Windows®

- (1) Try pinging the print server from the host operating system command prompt with the command:

```
ping ipaddress
```

Where ipaddress is the print server IP address (note that in some instances it can take up to two minutes for the print server to load its IP address after setting the IP address).

- (2) If a successful response is received, then proceed to Windows® 95/98/Me and Windows NT® 4.0 Peer-to-Peer print (LPR) troubleshooting, and Windows® 2000/XP IPP troubleshooting. Otherwise, proceed to Step 4.

For Macintosh®

For Mac OS® 9.1 to 9.2

- (1) From the **Apple** menu, open the **Chooser**.
- (2) Click the **Brother Laser (IP)** icon, and make sure that your print server name appears in the right frame. If it is visible, then the connection is good. Otherwise, go to Step (4).

For Mac OS® X 10.2.4 or greater

- (1) From the **Go** menu, select **Applications**.
- (2) Open the **Utilities** folder.
- (3) Double-click the **Printer Setup Utility** icon.
- (4) Click **Add**.
- (5) Make the following selection. Make sure that your print server appears. If it is visible, then the connection is good.

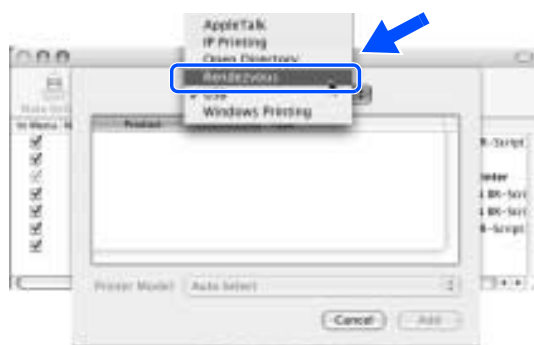

4. If you have tried 1 to 4 above and it does not work, then reset the print server back to the default factory settings and try from the initial setup again.

<Error during printing>

If you try to print while other users are printing large amounts of data (e.g. many pages or color pages with high resolution), the printer is unable to accept your print job until the ongoing printing is finished. If the waiting time of your print job exceeds a certain limit, a time out situation occurs, which causes the error message. In such situations, execute the print job again after the other jobs are completed.

■ Protocol-specific troubleshooting

<Windows® 95/98/Me and Windows NT® 4.0 Peer-to-Peer print (LPR) troubleshooting>

If you are having trouble printing on a Windows® 95/98/Me, Windows NT® 4.0 or later Peer-to-Peer network (LPR method), check the following:

1. Make sure that the Brother LPR Port driver is correctly installed and configured according to the Windows® 95/98/Me or Windows NT® 4.0 Peer-to-Peer chapters.
2. Try to turn the **Byte Count** on in the **Configure port** area of printer driver properties.

You may find that during the installation of BLP software, the screen that prompts you for a Port name is not displayed. This may happen on some Windows® 95/98/Me and Windows NT® 4.0 computers. Press the ALT and TAB keys to make it appear.

<Windows® 95/98/Me and Windows NT® 4.0 Peer-to-Peer print (NetBIOS) troubleshooting>

If you are having trouble printing on a Windows® 95/98/Me, Windows NT® 4.0 or later Peer-to-Peer network (NetBIOS), check the following:

1. Make sure that the Brother NetBIOS Port driver is correctly installed and configured according to the Windows® 95/98/Me or Windows NT® 4.0 Peer-to-Peer (NetBIOS) chapters. You may find that during the installation of the port driver, the screen that prompts you for a Port name is not displayed. This happens on some Windows® 95/98/Me and Windows NT® 4.0 computers. Press the ALT and TAB keys to make it appear.
2. Make sure that the print server is configured to be in the same workgroup or domain as the rest of your computers. It may take several minutes for the print server to appear in the network neighborhood.

<Windows® 2000/XP IPP troubleshooting>

Want to use a different Port number other than 631.

If you are using Port 631 for IPP printing, you may find that your firewall may not let the print data through. If this is the case, use a different port number (port 80), or configure your Firewall to allow Port 631 data through.

To send a print job using IPP to a printer using Port 80 (the standard HTTP port) enter the following when configuring your Windows® 2000/XP system.

http://ip_address/ipp

Get More Info option in Windows® 2000 not working

If you are using a URL of:

http://ip_address:631 or http://ip_address:631/ipp ,

the **Get More Info** option in Windows® 2000 will not function. If you wish to use the **Get More Info** option, use the following URL:

http://ip_address

<Web browser troubleshooting (TCP/IP)>

1. If you can not connect to the print server using your web browser it may be worth checking the Proxy Settings of your browser. Look in the Exceptions setting and if necessary, type in the IP address of the print server. This will stop your PC from trying to connect to your ISP or proxy server every time you wish to look at the printer server.
2. Make sure that you are using the proper web browser, we recommend Netscape Navigator® version 4.0 or later/ Microsoft Internet Explorer® version 5.0 or later.

[7] Troubleshooting of the control panel

L-1	Nothing is displayed on the LCD.
-----	----------------------------------

 User Check (1) Verify if the power switch is turned off.

Possible cause	Step	Check	Result	Remedy
Connection between main PCB and control panel PCB	1	Main PCB and control panel PCB are properly connected	No	Fix the connector properly.
Harness between main PCB and control panel PCB	2	Harness is damaged.	Yes	Replace the harness with a normal part.
Connection between main PCB and low-voltage power supply PCB	3	Main PCB and low-voltage power supply PCB are properly connected.	No	Fix the connection properly.
Harness between main PCB and low-voltage power supply PCB LCD	4	Harness is damaged.	Yes	Replace the harness with a normal part.
LCD	5	Replacement of LCD solves the problem.	Yes	Replace the LCD with a normal part.
Control panel PCB	6	Replacement of control panel PCB solves the problem.	Yes	Replace the control panel PCB with a normal part.
Low-voltage power supply PCB	7	Replacement of low-voltage power supply PCB solves the problem.	Yes	Replace the low-voltage power supply PCB with a normal part.
Main PCB	8	Replacement of main PCB solves the problem.	Yes	Replace the main PCB with a normal part.

L-2	The control panel does not work.
-----	----------------------------------

 User Check (1) No

Possible cause	Step	Check	Result	Remedy
Key sticking	1	Any key on control panel is stuck.	Yes	Clean up the panel cover, or remove the burrs from panel cover and panel keys.
Connection between main PCB and control panel PCB	2	Main PCB and control panel PCB are properly connected.	No	Fix the connection properly.
Harness between main PCB and control panel PCB	3	Harness is damaged.	Yes	Replace the harness with a normal part.
Rubber key	4	Replacement of rubber key solves the problem	Yes	Replace the rubber key with a normal part.
Control panel PCB	5	Replacement of control panel PCB solves the problem.	Yes	Replace the control panel PCB with a normal part.
Main PCB	6	Replacement of main PCB solves the problem.	Yes	Replace the main PCB with a normal part.

L-3	Printing from Macintosh applications fails.
-----	---------------------------------------------

 User Check (1) Verify that the printer driver supplied with the printer has been installed in the system folder and selected in the selector. (2) Check the port selected in the selector. The selected port has to match the actual port to which the printer cable is connected.

Possible cause	Step	Check	Result	Remedy
Fault in printer	1	Test page can be printed using the method described in 8.4.5 'Test Pattern 1' in Chapter 8.	No	Check the symptom of the problem and refer to an appropriate section in this Chapter to solve the problem.
Breakage of main PCB	2	Printing can be made using an appropriate PC, printer cable, and RS-100M?	No	Replace the main PCB.

[8] Troubleshooting of fax functions

F-1	FAX can't send it.
-----	--------------------

 User Check (1) Verify that the telephone cord is securely inserted.

Possible cause	Step	Check	Result	Remedy
Dialing mode setting	1	Dialing signal (PB or DP) comes out normally in each mode. (Use telephone line emulator.)	Yes	Check the dialing mode setting at customer's again. Check the telephone line cord between machine and socket.
Connection between main PCB and NCU PCB	2	Main PCB and NCU PCB are properly connected.	No	Fix the connection properly.
Harness between main PCB and NCU PCB	3	Harness is damaged.	Yes	Replace the harness with a normal part.
Connection between main PCB and control panel PCB	4	Main PCB and control panel PCB are properly connected.	No	Fix the connection properly.
Harness between main PCB and control panel PCB	5	Harness is damaged.	Yes	Replace the harness with a normal part.
Contact of rubber key	6	The rubber key works correctly.	No	Replace the rubber key with a normal part.
NCU PCB	7	Replacement of NCU PCB solves the problem.	Yes	Replace the NCU PCB with a normal part.
Control panel PCB	8	Replacement of control panel PCB solves the problem.	Yes	Replace the control panel PCB with a normal part.
Main PCB	9	Replacement of main PCB solves the problem.	Yes	Replace the main PCB with a normal part.

F-2	Speed dialing and One-touch dialing can't be used.
-----	----------------------------------------------------

Possible cause	Step	Check	Result	Remedy
Speed dialing, One-touch dialing	1	A fax transmission can be made using the key, ten?	Yes	Replace the main PCB.
Dialing mode setting	2	Dialing signal (PB or DP) comes out normally in each mode. (Use telephone line emulator.)	Yes	Check the dialing mode setting at customer's again. Check the telephone line cord between machine and socket.
Connection between main PCB and NCU PCB	3	Main PCB and NCU PCB are properly connected.	No	Fix the connection properly.
Harness between main PCB and NCU PCB	4	Harness is damaged.	Yes	Replace the harness with a normal part.
Connection between main PCB and control panel PCB	5	Main PCB and control panel PCB are properly connected.	No	Fix the connection properly.
Harness between main PCB and control panel PCB	6	Harness is damaged.	Yes	Replace the harness with a normal part.
Rubber key	7	Replacement of rubber key solves the problem.	Yes	Replace the rubber key with a normal part.
NCU PCB	8	Replacement of NCU PCB solves the problem.	Yes	Replace the NCU PCB with a normal part.
Control panel PCB	9	Replacement of control panel PCB solves the problem.	Yes	Replace the control panel PCB with a normal part.

F-3	FAX can't be received.
-----	------------------------

<input checked="" type="checkbox"/> User Check (1) Verify that the telephone cord is securely inserted.

Possible cause	Step	Check	Result	Remedy
Receive mode setting	1	Receive mode is set to automatic receive mode.	No	Set the receive mode to automatic receive mode.
NCU PCB	2	Replacement of NCU PCB solves the problem.	Yes	Replace the NCU PCB with a normal part.
Main PCB	3	Replacement of main PCB solves the problem.	Yes	Replace the main PCB with a normal part.

F-4	No bell ring.
-----	---------------

Possible cause	Step	Check	Result	Remedy
Ring delay	1	Ring delay is set to "0".	Yes	Set the ring delay to other than "0".
Ring volume	2	Ring volume is set to "OFF".	Yes	Set the ring volume to other than "OFF".
Harness between main PCB and scanner unit	3	Harness is damaged.	Yes	Replace the harness with a normal part.
Connection between main PCB and NCU PCB	4	Main PCB and NCU PCB are properly connected.	No	Fix the connection properly.
Harness between main PCB and NCU PCB	5	Harness is damaged.	Yes	Replace the harness with a normal part.
Speaker	6	Replacement of speaker solves the problem.	Yes	Replace the speaker with a normal part.
NCU PCB	7	Replacement of NCU PCB solves the problem.	Yes	Replace the NCU PCB with a normal part.
Main PCB	8	Replacement of main PCB solves the problem.	Yes	Replace the main PCB with a normal part.

F-5	Speaker is silent during on-hook dialing.
-----	-------------------------------------------

Possible cause	Step	Check	Result	Remedy
Connection between main PCB and speaker	1	Main PCB and speaker are properly connected.	No	Fix the connection properly.
Speaker	2	Replacement of speaker solves the problem.	Yes	Replace the speaker with a normal part.
Connection between main PCB and NCU PCB	3	Main PCB and NCU PCB are properly connected.	No	Fix the connection properly.
Harness between main PCB and NCU PCB	4	Harness is damaged.	Yes	Replace the harness with a normal part.
Connection between main PCB and control panel PCB	5	Main PCB and control panel PCB are properly connected.	No	Fix the connection properly.
Harness between main PCB and control panel PCB	6	Harness is damaged.	Yes	Replace the harness with a normal part.
NCU PCB	7	Replacement of NCU PCB solves the problem.	Yes	Replace the NCU PCB with a normal part.
Main PCB	8	Replacement of main PCB solves the problem.	Yes	Replace the main PCB with a normal part.

F-6	Dialing function does not switch between "tone" and "pulse".
-----	--------------------------------------------------------------

Possible cause	Step	Check	Result	Remedy
Connection between main PCB and NCU PCB	1	Main PCB and NCU PCB are properly connected.	No	Fix the connection properly.
Harness between main PCB and NCU PCB	2	Harness is damaged.	Yes	Replace the harness with a normal part.
NCU PCB	3	Replacement of NCU PCB solves the problem.	Yes	Replace the NCU PCB with a normal part.
Main PCB	4	Replacement of main PCB solves the problem.	Yes	Replace the main PCB with a normal part.

MFC7420/7820N DCP7010/7020/7025

APPENDIX 1. SERIAL NUMBERING SYSTEM

This appendix shows the location of serial number labels put on some parts and lists the coding information pertaining to the serial numbers.

Confidential

SERIAL NUMBERING SYSTEM

Individual machines have a serial number label for the machine itself and a property label for the head/carriage unit.

This section lists the coding information for those serial numbers and property codes.

(1) Serial number label for the machine itself

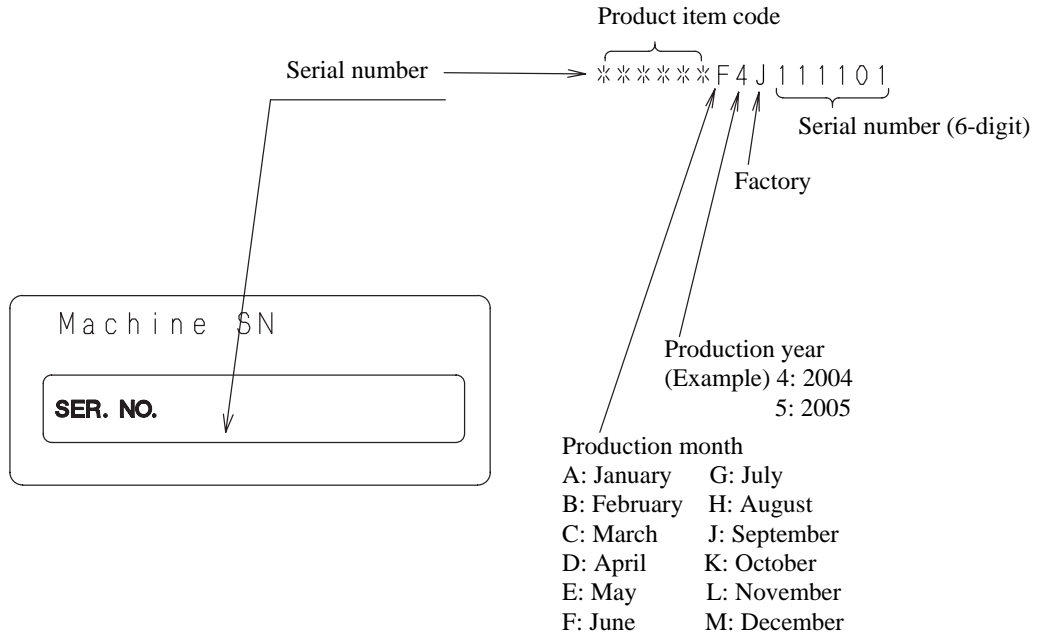

Location

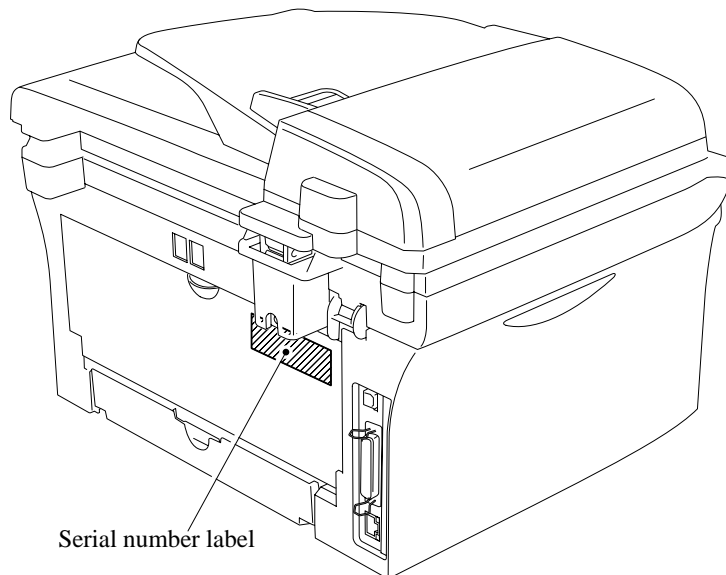

(2) Laser unit serial label

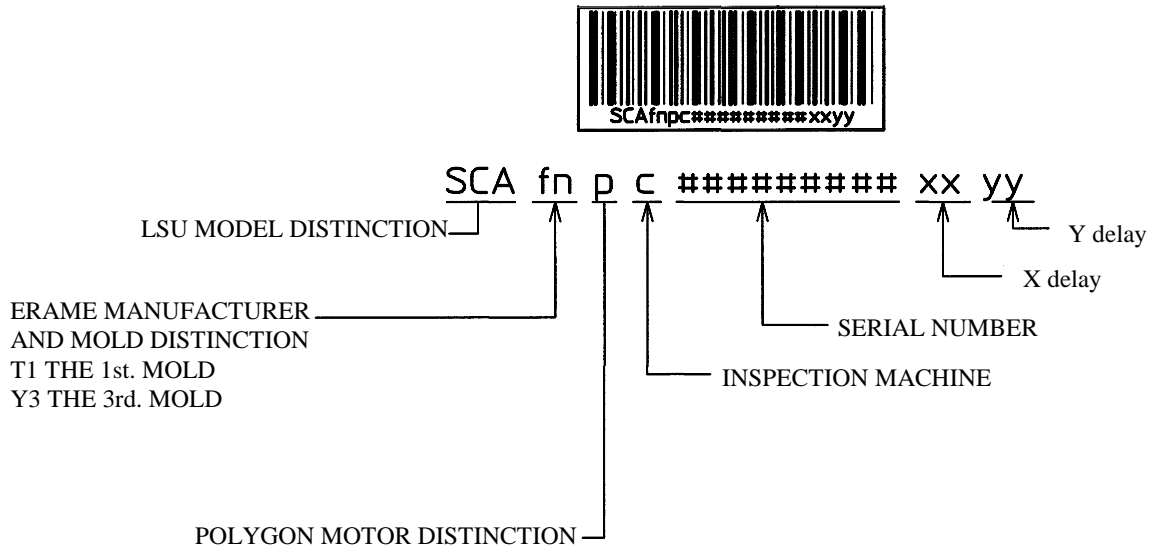

REGARDING X delay and Y delay

It indicates required delay amount for writing in each of main (X) and sub (Y) scanning direction

Location

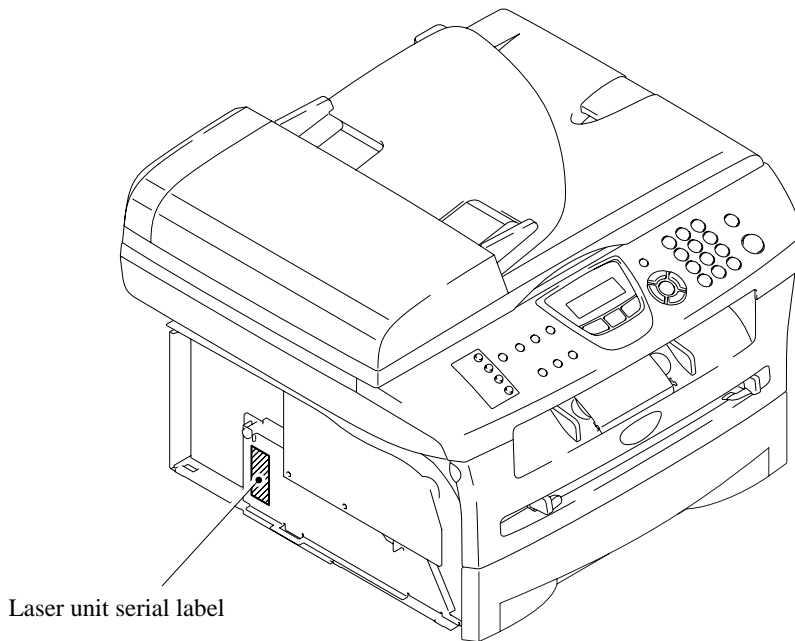

MFC7420/7820N DCP7010/7020/7025

APPENDIX 2. FIRMWARE INSTALLATION

This appendix provides instructions on how to update firmware stored in the flash ROM on the main PCB or load firmware to a new main PCB from the host PC.
No hardware replacement is required for updating.

A2.1	INSTALLING THE UPDATE DATA TO THE MACHINE	App. 2-1
A2.2	SETTING ID CODES TO MACHINES	App. 2-9

Confidential

A2.1 INSTALLING THE UPDATE DATA TO THE MACHINE

If you want to update the current program stored in the flash ROM of the main PCB to the newer version or after you replace the main PCB, install the update program onto the flash ROM.

The program installation requires a PC/AT-compatible computer (which is capable of running MS-DOS or its compatible OS).

■ If you use parallel interface

Connecting the Machine to Your PC

- (1) Make sure that your PC is turned off.
- (2) Make sure that the power cord of the machine is unplugged from a wall socket or other power source.
- (3) Connect the parallel interface cable to the parallel port on the back of the machine and secure it with the lock wires.
- (4) Connect the other end of the interface cable to the printer port of your PC and secure it with the two screws.

Setting up the Machine and Your PC

- (1) Plug the power cord of the machine into a wall socket, and turn on the power switch while pressing the **5** key on the machine's control panel.
- (2) Check to see that the following pattern displays on the LCD. If it does not display, go back to step (2) above.

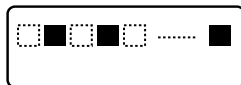

- (3) Turn on your PC.

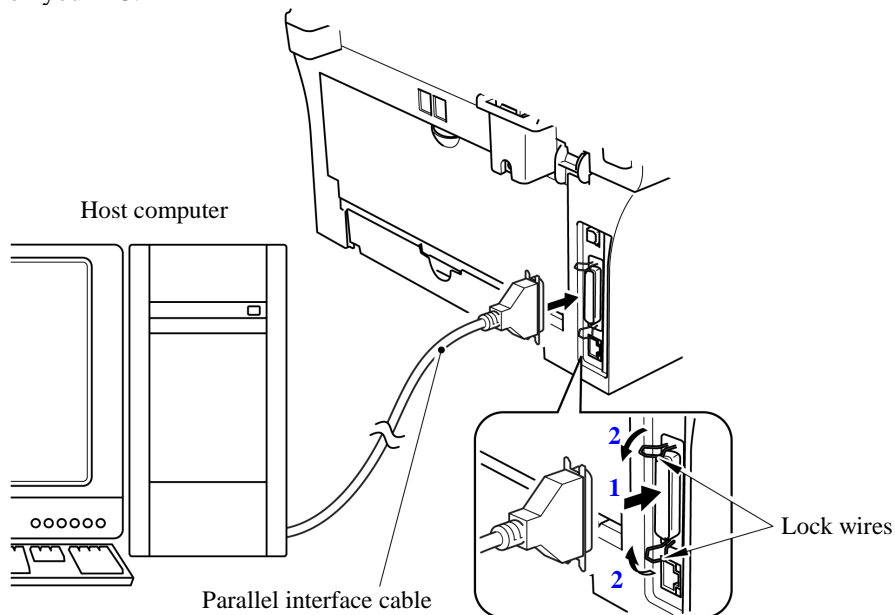

Installing the Update Data onto the Flash ROM of the Machine

■ On a PC running Windows 95

- (1) Copy the update data and transfer utility onto the desired same directory of the hard disk. e.g., C:\UPDATE
- (2) Click the **Start** button, point to Programs, and then click MS-DOS Prompt to open an MS-DOS window.
- (3) Type the drive letter where the update data and transfer utility are located. In the above example, type C:\ from the command line and press the **Enter** key.
Then type CD UPDATE and press the **Enter** key.
- (4) To start the transfer utility transmitting the update data to the flash ROM of the machine, type the following:

ICEN *filename* /b

Where *filename* is an update data file, e.g., 7820xxxx.dat.

Then press the **Enter** key.

During downloading, the machine beeps *intermittently*.

Upon completion of the downloading, the machine beeps *continuously*.

NOTE: If the machine cannot return to the standby state after completion of downloading, turn the power off and on.

■ On a PC running Windows 98/Me/2000

- (1) Install the printer driver for the parallel port to your PC. (Once installed, no more printer driver is required for your PC.)
- (2) Copy the update data onto the desired directory of the hard disk.
e.g., C:\UPDATE
- (3) Copy the transfer utility "Filedg32.exe" onto the desired directory of the hard disk.
- (4) Run "Filedg32.exe".
The Filedrgs window will appear as shown below. (e.g., MFC7820N)
- (5) Drag and drop the update data onto the icon of the model being used in the Filedrgs windows.
During downloading, the machine beeps *intermittently*.
Upon completion of the downloading, the machine beeps *continuously*.

NOTE: If the machine cannot return to the standby state after completion of downloading, turn the power off and on.

■ If you use USB cable

Preparation

You need to have the BHL2-Maintenance Printer driver and FILEDG32.exe (provided by Brother Industries) on hand. Save them in an arbitrary folder in your PC.

Installing the BHL2-Maintenance Printer driver

To identify terminals connected via USB interface, a PC requires the corresponding virtual USB devices to be implemented by driver/software. If you connect any number of machines to your PC, therefore, the same number of virtual USB devices will be automatically configured on your PC. To prevent virtual USB devices from being configured limitlessly, use the unique driver installation procedure described below that enables your PC to identify terminals via a single virtual USB device.

NOTE: Once this installation procedure is carried out for a PC, no more driver/software installation will be required for that PC to identify machines. If the BHL2-Maintenance Printer driver has been already installed to your PC according to this procedure, skip this section.

NOTE: Before proceeding to the procedure given below, make sure that the BHL2-Maintenance Printer driver is stored in your PC.

- (1) Make sure that the power cord of the machine is unplugged from the electrical outlet. If the machine is connected to a PC, unplug the USB cable.
- (2) Switch on your PC.
- (3) Plug the power cord of the machine into an electrical outlet.
- (4) Press the **Menu/Set** and **Black Start** keys. Next press the **▲** key four times to make the machine enter the maintenance mode. (Refer to [Chapter 8](#).)

TIP: FAX models equipped with numerical keypads can enter the maintenance mode in the same way as conventional models; that is, by pressing the **Menu/Set**, *****, **2**, **8**, **6** and **4** keys in this sequence.

- (5) Connect the machine to your PC using the USB cable. The following window appears.

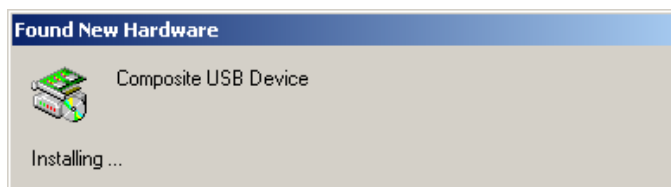

- (6) The following screen appears, indicating the detection of new hardware device by the system. Click **Next** to proceed.



- (7) Select "Search for a suitable driver for my device (recommended)" and click **Next**.

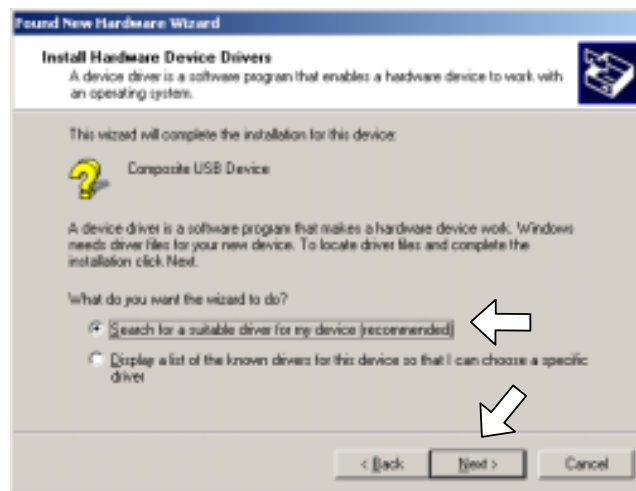

- (8) Select "Specify a location" and click **Next**.

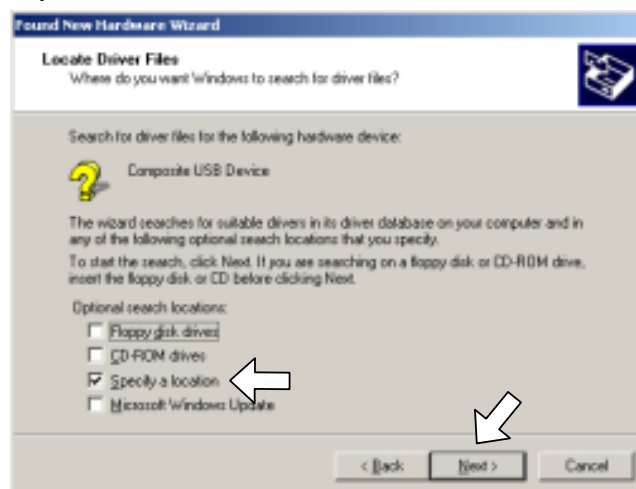

- (9) Select the folder where the copy of the BHL2-Maintenance Printer driver is located (or click **Browse** to specify it), then click **OK**.
(This sample screen is captured on the Windows 2000 desktop.)

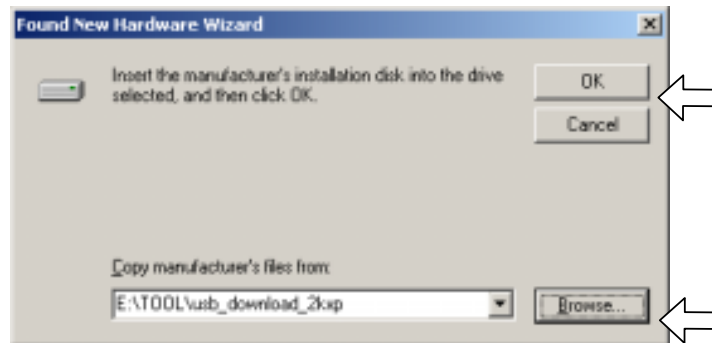

- (10) Click **Next**.

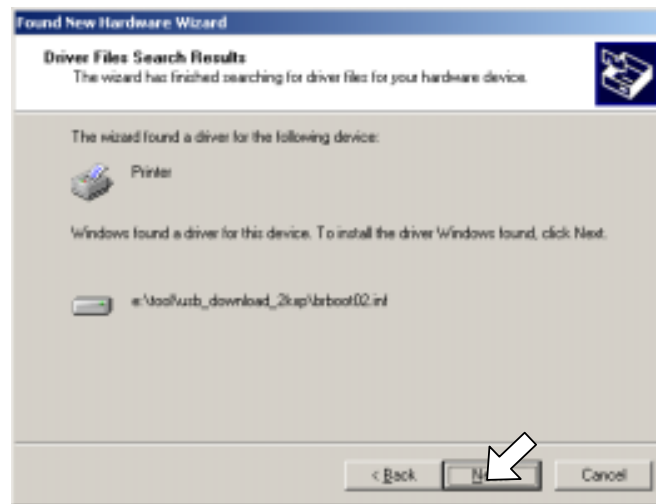

- (11) To proceed, click **Yes**.

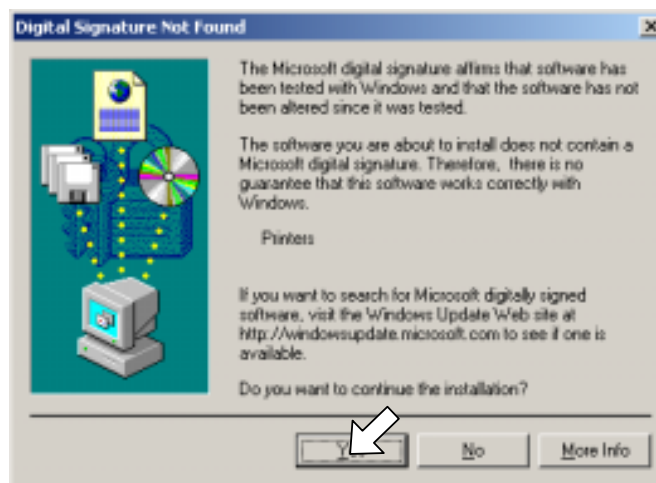

- (12) If the driver is successfully installed, the following message window appears. Click **Finish** to return to Windows.

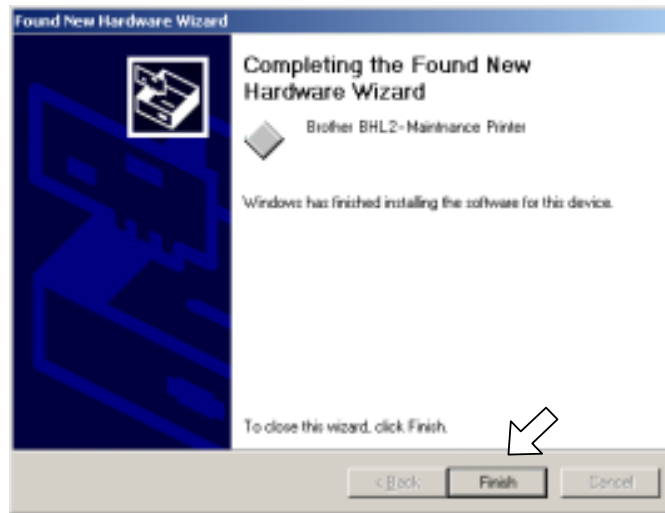

NOTE: After completion of the driver installation, if the machine exits the maintenance mode, the "Found New Hardware Wizard" screen in step (6) appears again. Click **Cancel**.

NOTE: To check that the printer driver is successfully installed, click **Start|Settings|Printers** to call up the Printers window as shown below and confirm that the Brother BHL2-Maintenance Printer icon is displayed.

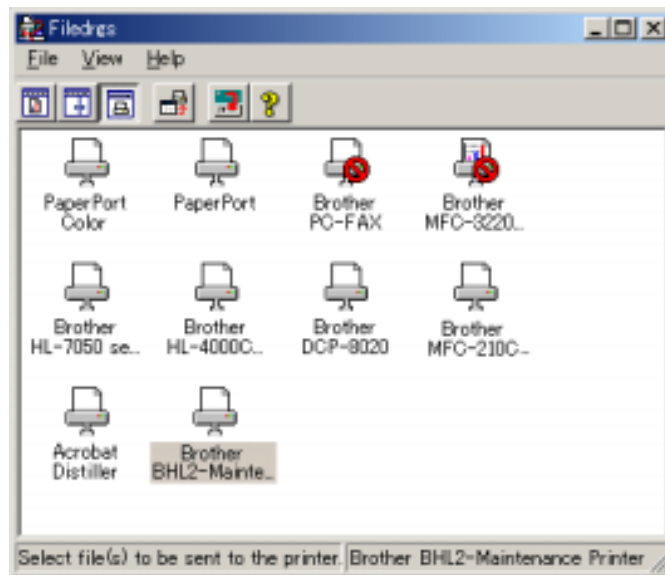

Writing the update programs/data onto the flash ROM of the machine

After the installation procedure of the printer driver, proceed to the firmware writing operation. If the printer driver has been installed so that you start from writing firmware, unplug the power cord from the electrical outlet.

MFC7820N/7420

While holding down the **5** key, plug the power cord into an electrical outlet.

DCP7010/7020/7025

While holding down the **Number of Copies** key, plug the power cord into an electrical outlet.

The machine should show the black and white pattern on the LCD.

NOTE: Never unplug the machine's or PC's power cord or the USB cable during writing.

- (1) Run "FILEDRG32.exe."

The Filedrgs window will appear as shown below.

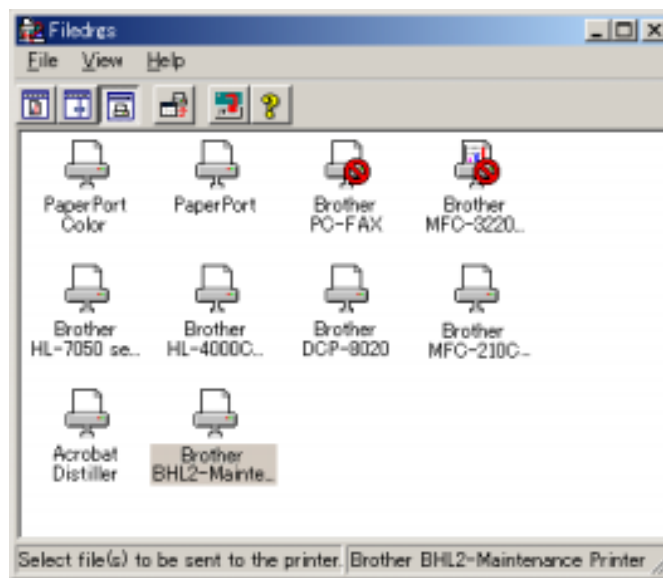

- (2) Drag and drop the firmware (e.g., LZ0023_A.upd) onto the BHL2-Maintenance Printer icon in the Filedrgs window shown above.

NOTE: Use a firmware file after extracting. It is a self-extracting file having the extension .exe. Double-click the exe file to extract it.

When writing operation starts, the machine beeps intermittently. After approx. 2 to 5 minutes, the writing operation is complete and the machine automatically reboots and returns to the standby state.

(3) MFC7420/7820N

Press the * and # keys at the same time when the machine is on standby. The firmware version appears on the LCD.

DCP7010/7020/7025

Press the **Menu** and **Start** keys. Next press the ▲ key four times to make the machine enter the maintenance mode.

Press the ▲ key several times to display 8 on the LCD and then press the **Set** key. Again press the ▲ key several times to display 0 and press the **Set** key.

Press the **Start** key several times to display the firmware version.

In this example, if "A0307252244:CF30" appears, it means that the downloading has been successfully finished.

NOTE: The latest firmware will display its version on the LCD by pressing the Stop and ▲ keys at the same time.

- (4) If downloading finishes abnormally, turn the machine off and on. The machine automatically enters the write mode and emits a large beep. Perform the writing procedure above again.

A2.2 SETTING ID CODES TO MACHINES

Brother driver machines are assigned unique ID codes (character strings) at the factory. If you replace the main PCB of the machine, the machine will lose its assigned ID code so that it will not be identified by the connected PC*.

You need to assign a unique ID code (character string) to the machine according to the procedure given here. For models covered by this manual, set serial numbers given to individual machines as ID codes.

(* ID codes are essential when more than one machine is connected to a single PC via USB.)

Please check the printer driver of MFC7420, MFC7820N, DCP7010, DCP7020 or DCP7025 is installed in a host computer before working. When not installed. Please install a printer driver in a host computer before working.

- (1) Double-click the brmainte.EXE file (maintenance utility).
- (2) Select Input Information from Menu. Select the applicable model name.
- (3) Check the port (USB) which the printer is connected through and click "Serial No." in the lower box. Enter the serial number (the last nine digits) of the printer into the box at the right hand side and click the **OK** button. The serial number is shown in the window, and check that it is correct. The setting of the serial number is completed.

MFC7420/7820N DCP7010/7020/7025

APPENDIX 3. CUSTOMIZING CODES ACCORDING TO SHIPPING DESTINATION

This appendix lists the customizing codes for the various preferences exclusively designed for each destination (e.g. language). Those codes are stored in the memory (EEPROM) mounted on the main PCB. If the main PCB is replaced with a new one, therefore, you will need to set the proper customizing codes with the machine in the maintenance mode.

Confidential

EEPROM CUSTOMIZING CODES

This function allows you to customize the EEPROM according to language, function settings, and firmware switch settings.

■ Operating Procedure

- (1) Press the **Menu/Set (Menu)** and **Start** keys. Next press the **▲** key four times to make the machine enter the maintenance mode.

TIP: FAX models equipped with numerical keypads can enter the maintenance mode in the same way as conventional models; that is, by pressing the **Menu/Set**, *****, **2**, **8**, **6** and **4** keys in this sequence.

The machine beeps for approx. one second and displays "■■ MAINTENANCE ■■■" on the LCD.

- (2) MFC7420/7820N

Press the **7** and **4** keys in this order in the initial stage of the maintenance mode.

DCP7010/7020/7025

Enter **7** and **4** in the initial stage of the maintenance mode by using **▲** and **Set** keys.*

(*To enter a numerical code on models having no numerical keypad, press the **▲** key several times to display the numerical code to be entered and then press the **Set** key. Repeat this operation for each numerical code.)

The current customizing code appears (e.g., 8001 in the case of MFC7420 U.S.A. model).

- (3) Enter the desired customizing code (e.g., 0002 in the case of MFC7420 CANADA model). The newly entered code appears.

MFC7420/7820N

To enter letters "A" through "F," press the **1** through **6** keys while holding down the **#** key, respectively.

DCP7010/7020/7025

To enter the customizing code by using the **▲** and **Set** keys.*

NOTE: If a wrong 4-digit code is entered, the machine will malfunction.

- (4) Press the **Start** key.
The machine saves the setting and returns to the initial stage of the maintenance mode.
If you press the **Stop/Exit** key or no keys are pressed for one minute in the above procedure, the machine stops the procedure and returns to the initial stage of the maintenance mode.

MFC7420/7820N DCP7010/7020/7025

APPENDIX 4. FIRMWARE SWITCHES (WSW)

This appendix describes the functions of the firmware switches, which can be divided into two groups: one is for customizing preferences designed for the shipping destination (as described in [Appendix 3](#)) and the other is for modifying preferences that match the machine to the environmental conditions. Use the latter group if the machine malfunctions due to mismatching.

Confidential

WSW No.	Function	Refer to:
WSW01	Dial pulse setting	App. 4-3
WSW02	Tone signal setting	App. 4-4
WSW03	PABX mode setting	App. 4-5
WSW04	TRANSFER facility setting	App. 4-6
WSW05	1st dial tone and busy tone detection	App. 4-7
WSW06	Redial/Pause key setting and 2nd dial tone detection	App. 4-9
WSW07	Dial tone setting 1	App. 4-11
WSW08	Dial tone setting 2	App. 4-12
WSW09	Protocol definition 1	App. 4-13
WSW10	Protocol definition 2	App. 4-14
WSW11	Busy tone setting	App. 4-15
WSW12	Signal detection condition setting	App. 4-16
WSW13	Modem setting	App. 4-17
WSW14	AUTO ANS facility setting	App. 4-18
WSW15	REDIAL facility setting	App. 4-19
WSW16	Function setting 1	App. 4-20
WSW17	Function setting 2	App. 4-21
WSW18	Function setting 3	App. 4-22
WSW19	Transmission speed setting	App. 4-23
WSW20	Overseas communications mode setting	App. 4-24
WSW21	TAD setting 1	App. 4-25
WSW22	ECM and call waiting caller ID	App. 4-26
WSW23	Communications setting	App. 4-27
WSW24	TAD setting 2	App. 4-28
WSW25	TAD setting 3	App. 4-29
WSW26	Function setting 4	App. 4-30
WSW27	Function setting 5	App. 4-31
WSW28	Function setting 6	App. 4-32
WSW29	Function setting 7	App. 4-33
WSW30	Function setting 8	App. 4-34
WSW31	Function setting 9	App. 4-35
WSW32	Function setting 10	App. 4-36
WSW33	Function setting 11	App. 4-37
WSW34	Function setting 12	App. 4-38
WSW35	Function setting 13	App. 4-39
WSW36	Function setting 14	App. 4-40
WSW37	Function setting 15	App. 4-41

WSW No.	Function	Refer to:
WSW38	V.34 transmission settings	App. 4-42
WSW39	V.34 transmission speed	App. 4-43
WSW40	V.34 modem settings	App. 4-44
WSW41	ON-duration of the scanning light source	App. 4-46
WSW42	Internet mail settings	App. 4-47
WSW43	Function setting 21	App. 4-47
WSW44	Speeding up scanning-1	App. 4-48
WSW45	Speeding up scanning-2	App. 4-49
WSW46	Monitor of power ON/OFF state and parallel port kept at high	App. 4-50
WSW47	Switching between high- and full-speed USB	App. 4-51
WSW48	USB setup latency	App. 4-52
WSW49	End-of-copying beep and print in black	App. 4-52
WSW50	SDAA settings	App. 4-53
WSW51	Function setting 16	App. 4-54

WSW01 (Dial pulse setting)

Selector No.	Function	Setting and Specifications
1 2	Dial pulse generation mode	No. 1 2 0 0 : N 0 1 : N+1 1 0 : 10-N 1 1 : N
3 4	Break time length in pulse dialing	No. 3 4 0 0 : 60 ms 0 1 : 67 ms 1 0 : 40 ms (for 16 PPS) 1 1 : 64 ms (at 106-ms intervals)
5 6	Inter-digit pause	No. 5 6 0 0 : 800 ms 0 1 : 850 ms 1 0 : 950 ms 1 1 : 600 ms
7	Switching between pulse (DP) and tone (PB) dialing, by the function switch	0: Yes 1: No
8	Default dialing mode, pulse (DP) or tone (PB) dialing	0: PB 1: DP

• **Selectors 1 and 2: Dial pulse generation mode**

These selectors set the number of pulses to be generated in pulse dialing.

N: Dialing "N" generates "N" pulses. (Dialing "0" generates 10 pulses.)

N + 1: Dialing "N" generates "N + 1" pulses.

10 - N: Dialing "N" generates "10 - N" pulses.

• **Selectors 3 and 4: Break time length in pulse dialing**

These selectors set the break time length in pulse dialing.

(Example: If "1," "2," and "3" are dialed when N is set by selectors 1 and 2.)

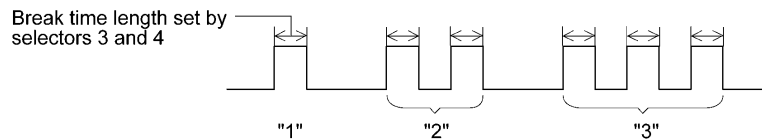

• **Selectors 5 and 6: Inter-digit pause**

These selectors set the inter-digit pause in pulse dialing.

(Example: If "1," "2," and "3" are dialed when N is set by selectors 1 and 2.)

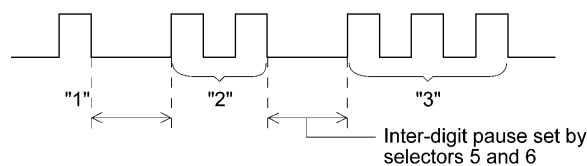

- **Selector 7: Switching between pulse (DP) and tone (PB) dialing, by the function switch**

This selector determines whether or not the dialing mode can be switched between the pulse (DP) and tone (PB) dialing by using the function switch.

- **Selector 8: Default dialing mode, pulse (DP) or tone (PB) dialing**

This selector sets the default dialing mode (pulse dialing or tone dialing) which can be changed by the function switch. If the user switches it with the function switch when selector 7 is set to "0," the setting specified by this selector will also be switched automatically.

WSW02 (Tone signal setting)

Selector No.	Function	Setting and Specifications
1 2	Tone signal transmission time length	No. 1 2 0 0 : 70 ms 0 1 : 80 ms 1 0 : 90 ms 1 1 : 100 ms
3 4	Min. pause in tone dialing	No. 3 4 0 0 : 70 ms 0 1 : 80 ms 1 0 : 90 ms 1 1 : 140 ms
5 8	Attenuator for pseudo ring backtone to the line (selectable in the range of 0-15 dB, in 1 dB increments)	0: 0 dB 1: 8 dB 0: 0 dB 1: 4 dB 0: 0 dB 1: 2 dB 0: 0 dB 1: 1 dB

- **Selectors 1 through 4: Tone signal transmission time length and Min. pause in tone dialing**

These selectors set the tone signal transmission time length and minimum pause in tone dialing. (Example: If "1," "2," "3," "4," and "5" are dialed.)

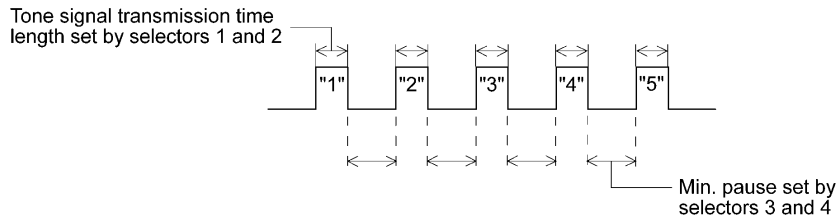

- **Selectors 5 through 8: Attenuator for pseudo ring backtone to the line**

These selectors are used to adjust the sound volume of a ring backtone in the F/T mode, an on-hold sound, or a beep generated as a signal during remote control operation or at the start of ICM recording.

The larger the value specified by these selectors, the greater the attenuation.

WSW03 (PABX* mode setting)

Selector No.	Function	Setting and Specifications
1	CNG detection when sharing a modular wall socket with a telephone	0: A 1: B
2 4	Detection time length of PABX* dial tone, required for starting dialing (Not used.)	No. 2 3 4 0 0 0 : 50 ms 0 0 1 : 210 ms 0 1 0 : 500 ms 0 1 1 : 800 ms 1 0 0 : 900 ms 1 0 1 : 1.5 sec. 1 1 0 : 2.0 sec. 1 1 1 : 2.5 sec.
5	CNG detection when sharing a modular wall socket with a telephone	0: A 1: B
6 7	Dial tone detection in PABX* (Not used.)	No. 6 7 0 0 : No detection (3.5 sec. WAIT) 0 1 : No detection (5 sec. WAIT) 1 0 : No detection (7 sec. WAIT) 1 1 : Detection (Frequency only)
8	Not used.	

* PABX: Private automatic branch exchange

NOTE: Selectors 2 through 4, 6 and 7 are not applicable where no PABX is installed.

• **Selectors 1 and 5: CNG detection when sharing a modular wall socket with a telephone**

These selectors determine whether or not the machine detects a CNG signal when a line is connected to a telephone sharing a modular wall socket with the machine. Upon detection of CNG signals by the number of cycles specified by these selectors, the machine interprets CNG as an effective signal and then starts FAX reception.

Selector No. 1 No. 5		Cycle
0 (A)	0 (A)	0.5 cycle
0 (A)	1 (B)	1.0 cycle
1 (B)	0 (A)	1.5 cycles
1 (B)	1 (B)	2.0 cycles

• **Selectors 2 through 4: Detection time length of PABX dial tone, required for starting dialing (Not used.)**

Upon detection of the PABX dial tone for the time length set by these selectors, the machine starts dialing.

These selectors are effective only when both selectors 6 and 7 are set to "1" (Detection).

- **Selectors 6 and 7: Dial tone detection in PABX (Not used.)**

These selectors activate or deactivate the dial tone detection function which detects a dial tone when a line is connected to the PABX.

Setting both of these selectors to "1" activates the dial tone detection function so that the machine starts dialing upon detection of a dial tone when a line is connected.

Other setting combinations deactivate the dial tone detection function so that the machine starts dialing after the specified WAIT (3.5, 5.0, or 7.0 sec.) without detection of a dial tone when a line is connected.

WSW04 (TRANSFER facility setting)

Selector No.	Function	Setting and Specifications
1	Earth function in transfer facility (Not used.)	0: Provided 1: Not provided
2 3	Dual tone detection frequency in ICM recording	No. 2 3 0 0 : 350 and 440 Hz (A) 0 1 : 440 and 480 Hz (B) 1 0 : } 480 and 620 Hz (C) 1 1 : }
4	Dual tone detection sensitivity in ICM recording	0: Normal 1: High
5 6	Earth time length for earth function	No. 5 6 0 0 : 200 ms 0 1 : 300 ms 1 0 : 500 ms 1 1 : 700 ms
7 8	Break time length for flash function	No. 7 8 0 0 : 80 ms 0 1 : 110 ms 1 0 : 250 ms 1 1 : 500 ms

NOTE: Selectors 1 and 5 through 8 are not applicable in those countries where no transfer facility is supported.

NOTE: Selectors 2 through 4 are applicable to models equipped with built-in TADs.

- **Selector 1: Earth function in transfer facility (Not used.)**

This selector determines whether or not the earth function is added to the transfer setting menu to be accessed by the function switch.

- **Selectors 2 and 3: Dual tone detection frequency in ICM recording**

If the machine detects either of the frequencies set by these selectors in ICM recording, it disconnects the line. For example, if these selectors are set to "0, 0," the machine disconnects the line upon detection of 350 Hz or 440 Hz.

- **Selector 4: Dual tone detection sensitivity in ICM recording**

Setting this selector to "1" increases the tone detection sensitivity in ICM recording.

- **Selectors 5 and 6: Earth time length for earth function (Not used.)**

These selectors set the short-circuiting time length of the telephone line (La or Lb) to ground. This setting is effective only when the earth function is selected for the **R** key by using the function switch.

- **Selectors 7 and 8: Break time length for flash function**

These selectors set the break time length.

This setting is effective only when the flash function is selected for the **Search/Speed Dial** key by using the function switch.

WSW05 (1st dial tone and busy tone detection)

Selector No.	Function	Setting and Specifications
1 3	1st dial tone detection	No. 1 2 3 0 0 0 : 3.5 sec. WAIT 0 0 1 : 7.0 sec. WAIT 0 1 0 : 10.5 sec. WAIT 0 1 1 : 14.0 sec. WAIT 1 0 0 : 17.5 sec. WAIT 1 0 1 : 21.0 sec. WAIT 1 1 0 : 24.5 sec. WAIT 1 1 1 : Detection (Without WAIT)
4	Max. pause time allowable for remote ID code detection	0 : 2 seconds 1: 1 second
5 6	Busy tone detection in automatic sending mode	No. 5 6 0 0 : No detection 0 1 : Detection only after dialing 1 0 : No detection 1 1 : Detection before and after dialing
7	Busy tone detection in automatic receiving mode	0: Yes 1: No
8	Not used.	

NOTE: Selectors 5 through 7 are not applicable in those countries where no busy tone detection is supported.

- **Selectors 1 through 3: 1st dial tone detection**

These selectors activate or deactivate the 1st dial tone detection function which detects the 1st dial tone issued from the PSTN when a line is connected to the PSTN.

Setting all of these selectors to "1" activates the dial tone detection function so that the machine starts dialing upon detection of a dial tone when a line is connected. (However, in those countries which support no dial tone detection function, e.g., in the U.S.A., setting these selectors to "1" makes the machine start dialing after a WAIT of 3.5 seconds.) For the detecting conditions of the 1st dial tone, refer to WSW07 and WSW08.

Other setting combinations deactivate the dial tone detection function so that the machine starts dialing after the specified WAIT (3.5, 7.0, 10.5, 14.0, 17.5, 21.0, or 24.5 seconds) without detection of a dial tone when a line is connected to the PSTN.

- **Selector 4: Max. pause time allowable for remote ID code detection**

This selector sets the maximum pause time allowable for detecting the second digit of a remote ID code after detection of the first digit in remote reception.

If selector 4 is set to "0" (2 seconds), for instance, only a remote ID code whose second digit is detected within 2 seconds after detection of the first digit will become effective so as to activate the remote function.

- **Selectors 5 and 6: Busy tone detection in automatic sending mode**

These selectors determine whether or not the machine automatically disconnects a line upon detection of a busy tone in automatic sending mode.

Setting selector 6 to "0" ignores a busy tone so that the machine does not disconnect the line.

Setting selectors 5 and 6 to "0" and "1," respectively, makes the machine detect a busy tone only after dialing and disconnect the line.

Setting both of selectors 5 and 6 to "1" makes the machine detect a busy tone before and after dialing and then disconnect the line.

- **Selector 7: Busy tone detection in automatic receiving mode**

This selector determines whether or not the machine automatically disconnects the line upon detection of a busy tone in automatic receiving mode.

WSW06 (Redial/Pause key setting and 2nd dial tone detection)

Selector No.	Function	Setting and Specifications
1 3	Redial/Pause key setting and 2nd dial tone detection	No.1 2 3 0 0 0 : No pause 0 0 1 : 3.5 sec. WAIT 0 1 0 : 7 sec. WAIT 0 1 1 : 10.5 sec. WAIT 1 0 0 : 14 sec. WAIT 1 1 0 : 2nd dial tone detection only in pulse dialing (DP) system 1 0 1 : } 2nd dial tone detection 1 1 1 : } both in DP and push-button (PB) dialing system
4 6	Detection of international tone	No.4 5 6 0 0 0 : 50 ms 0 0 1 : 210 ms 0 1 0 : 500 ms 0 1 1 : 800 ms 1 0 0 : 900 ms 1 0 1 : 1.5 sec. 1 1 0 : 2.0 sec. 1 1 1 : 2.5 sec.
7	No. of 2nd dial tone detection cycles	0: 1 cycle 1: 2 cycles
8	Allowable instantaneous interrupt during reception of 2nd dial tone	0: 30 ms 1: 50 ms

NOTE: Selectors 4 through 8 are not applicable in those countries where no dial tone detection is supported, e.g., U.S.A.

- **Selectors 1 through 3: Redial/Pause key setting and 2nd dial tone detection**

Selectors			
1	2	3	
0	0	0	No WAIT is inserted even if the Redial/Pause key is pressed.
0	0	1	If you press the Redial/Pause key during dialing, the machine will insert WAIT as defined in the above table. If the Redial/Pause key is pressed repeatedly, the machine inserts the specified WAIT multiplied by the number of depressions. It applies also in hook-up dialing.
0	1	0	
0	1	1	
1	0	0	
1	0	1	When these selectors are set to "1, 0, 1": Each time you press the Redial/Pause key in dialing, the machine will wait for the 2nd dial tone to be sent via the communications line regardless of pulse dialing or tone dialing. When these selectors are set to "1, 1, 0": If you press the Redial/Pause key in pulse dialing, the machine will first wait for the 2nd dial tone to be sent via the communications line. After that, pressing the Redial/Pause key will cause the machine to insert a WAIT of 3.5 seconds. In tone dialing, the machine will insert a WAIT of 3.5 seconds. When these selectors are set to "1, 1, 1": If you press the Redial/Pause key, the machine will first wait for the 2nd dial tone to be sent via the communications line regardless of pulse dialing or tone dialing. After that, pressing the Redial/Pause key will cause the machine to insert a WAIT of 3.5 seconds. (In those countries where no dial tone detection function is supported, setting these selectors to "1, 0, 1," "1, 1, 0," or "1, 1, 1" inserts a WAIT of 3.5 seconds.)
1	1	0	
1	1	1	

- **Selectors 4 through 6: Detection of international tone**

Upon detection of the 2nd dial tone for the time length specified by these selectors, the machine starts dialing.

This setting is effective only when the 2nd dial tone detection function is activated by selectors 1 through 3 (Setting 101, 110, or 111).

This function does not apply in those countries where no dial tone detection function is supported.

- **Selector 7: No. of 2nd dial tone detection cycles**

This selector sets the number of dial tone detection cycles required for starting dialing.

- **Selector 8: Allowable instantaneous interrupt during reception of 2nd dial tone**

This selector sets the allowable instantaneous interrupt period that should be ignored during reception of the 2nd dial tone.

WSW07 (Dial tone setting 1)

Selector No.	Function	Setting and Specifications
1 2	Dial tone frequency band control	No. 1 2 0 0 : Narrows by 10 Hz 0 1 : Initial value 1 X : Widens by 10 Hz
3	Line current detection (Not used.)	0: No 1: Yes
4 6	2nd dial tone detection level (Z = 600 Ω)	No. 4 5 6 0 0 0 : -21 dBm 0 0 1 : -24 dBm 0 1 0 : -27 dBm 0 1 1 : -30 dBm 1 0 0 : -33 dBm 1 0 1 : -36 dBm 1 1 0 : -39 dBm 1 1 1 : -42 dBm
7	Allowable instantaneous interrupt during reception of 1st dial tone	0: 30 ms 1: 50 ms
8	Not used.	

NOTE: Selectors 1, 2, 4 through 7 are not applicable in those countries where no dial tone or line current detection is supported, e.g., U.S.A.

NOTE: Selector 3 is not applicable to those models having no loop current detection function.

- **Selectors 1 and 2: Dial tone frequency band control**

These selectors set the frequency band for the 1st dial tone and busy tone (before dialing) to be detected.

This setting is effective only when selectors 1 through 3 on WSW05 are set to "1,1,1."

- **Selector 3: Line current detection (Not used.)**

This selector determines whether or not to detect a line current before starting dialing.

- **Selectors 4 through 6: 2nd dial tone detection level**

These selectors set the detection level of the 2nd dial tone.

- **Selector 7: Allowable instantaneous interrupt during reception of 1st dial tone**

This selector sets the allowable instantaneous interrupt period that should be ignored during reception of the 1st dial tone.

WSW08 (Dial tone setting 2)

Selector No.	Function	Setting and Specifications
1 3	1st dial tone detection time length	No. 1 2 3 0 0 0 : 50 ms 0 0 1 : 210 ms 0 1 0 : 500 ms 0 1 1 : 800 ms 1 0 0 : 900 ms 1 0 1 : 1.5 sec. 1 1 0 : 2.0 sec. 1 1 1 : 2.5 sec.
4 5	Time-out length for 1st and 2nd dial tone detection	No. 4 5 0 0 : 10 sec. 0 1 : 20 sec. 1 0 : 15 sec. 1 1 : 30 sec.
6 8	Detection level of 1st dial tone and busy tone before dialing	No. 6 7 8 0 0 0 : -21 dBm 0 0 1 : -24 dBm 0 1 0 : -27 dBm 0 1 1 : -30 dBm 1 0 0 : -33 dBm 1 0 1 : -36 dBm 1 1 0 : -39 dBm 1 1 1 : -42 dBm

NOTE: The WSW08 is not applicable in those countries where no dial tone detection is supported, e.g., U.S.A.

- **Selectors 1 through 3: 1st dial tone detection time length**

Upon detection of the 1st dial tone for the time length set by these selectors, the machine starts dialing.

This setting is effective only when selectors 1 through 3 on WSW05 are set to "1,1,1."

- **Selectors 4 and 5: Time-out length for 1st and 2nd dial tone detection**

These selectors set the time-out length for the 1st and 2nd dial tone detection so that the machine waits dial tone input for the specified time length and disconnects itself from the line when no dial tone is inputted.

WSW09 (Protocol definition 1)

Selector No.	Function	Setting and Specifications
1	Frame length selection	0: 256 octets 1: 64 octets
2	Use of non-standard commands	0: Allowed 1: Prohibited
3	No. of retries	No. 3 4
4		0 0 : 4 times
		0 1 : 3 times
		1 0 : 2 times
		1 1 : 1 time
5	T5 timer	0: 300 sec. 1: 60 sec.
6	T1 timer	0: 35 sec. 1: 40 sec.
7	Timeout for response from the called station in automatic sending mode	No. 7 8
8		0 0 : { 55 sec. (in U.S.A. and Canadian models)
		{ 60 sec. (in other models)
		0 1 : 140 sec.
		1 0 : 90 sec.
		1 1 : 35 sec.

NOTE: Selectors 1 through 5 are not applicable in those models which do not support ECM.

- **Selector 1: Frame length selection**

Usually a single frame consists of 256 octets (1 octet = 8 bits). For communications lines with higher bit error rate, however, set selector 1 to "1" so that the machine can divide a message into 64-octet frames.

Remarks: The error correction mode (ECM) is a facsimile transmission manner in which the machine divides a message into frames for transmission so that if any data error occurs on the transmission line, the machine retransmits only those frames containing the error data.

- **Selector 2: Use of non-standard commands**

If this selector is set to "0," the machine can use non-standard commands (the machine's native-mode commands, e.g., NSF, NSC, and NSS) for communications. If it is set to "1," the machine will use standard commands only.

- **Selectors 3 and 4: No. of retries**

These selectors set the number of retries in each specified modem transmission speed.

- **Selector 5: T5 timer**

This selector sets the time length for the T5 timer.

- **Selector 6: T1 timer**

This selector sets the time length for the T1 timer.

- **Selectors 7 and 8: Timeout for response from the called station in automatic sending mode**

If the machine (calling station) receives no response (no G3 command) from the called terminal in automatic sending mode for the period specified by these selectors, it disconnects the line.

WSW10 (Protocol definition 2)

Selector No.	Function	Setting and Specifications
1	Not used.	
2	Time length from transmission of the last dial digit to CML ON	0: 100 ms 1: 50 ms
3	Time length from CML ON to CNG transmission	0: 2 sec. 1: 4 sec.
4	Time length from CML ON to CED transmission (except for facsimile-to-telephone switching)	0: 0.5 sec. 1: 2 sec.
5 6	No. of training retries	No. 5 6 0 0 : 1 time 0 1 : 2 times 1 0 : 3 times 1 1 : 4 times
7	Encoding system (Compression)	MR 0: Allowed 1: Not allowed
8		MMR 0: Allowed 1: Not allowed

- **Selector 2: Time length from transmission of the last dial digit to CML ON**

This selector sets the time length from when the machine transmits the last dial digit until the CML relay comes on.

- **Selector 3: Time length from CML ON to CNG transmission**

This selector sets the time length until the machine transmits a CNG after it turns on the CML relay.

- **Selector 4: Time length from CML ON to CED transmission**

This selector sets the time length until the machine transmits a CED after it turns on the CML relay. This setting does not apply to switching between facsimile and telephone.

- **Selectors 5 and 6: No. of training retries**

These selectors set the number of training retries to be repeated before automatic fallback.

- **Selectors 7 and 8: Encoding system (Compression)**

This selector determines whether or not to allow the use of the MR/MMR coding system.

WSW11 (Busy tone setting)

Selector No.	Function	Setting and Specifications
1 2	Busy tone frequency band control	No. 1 2 0 0 : Narrows by 10 Hz 0 1 : Initial value 1 x : Widens by 10 Hz
3	ON/OFF time length ranges for busy tone (More than one setting allowed)	1: 250-750/250-750 ms
4		1: 400-600/400-600 ms
5		1: 175-440/175-440 ms
6		1: 100-1000 ms/17-660 ms
7		1: 110-410/320-550 ms
8		1: 100-660/100-660 ms

NOTE: WSW11 is not applicable in those countries where no busy tone detection is supported.

NOTE: The setting of WSW11 is effective only when selectors 5 and 6 on WSW05 are set to "0, 1" or "1, 1" (Busy tone detection).

- **Selectors 1 and 2: Busy tone frequency band control**

These selectors set the frequency band for busy tone to be detected.

- **Selectors 3 through 8: ON/OFF time length ranges for busy tone**

These selectors set the ON and OFF time length ranges for busy tone to be detected. If more than one selector is set to "1," the ranges become wider. For example, if selectors 4 and 5 are set to "1," the ON and OFF time length ranges are from 175 to 600 ms.

WSW12 (Signal detection condition setting)

Selector No.	Function	Setting and Specifications
1 2	Min. detection period required for interpreting incoming calling signal (CI) as OFF	No. 1 2 0 0 : 1500 ms 0 1 : 500 ms 1 0 : 700 ms 1 1 : 900 ms
3 4	Max. detection period for incoming calling signal (CI) being OFF	No. 3 4 0 0 : 6 sec. 0 1 : 7 sec. 1 0 : 9 sec. 1 1 : 11 sec.
5 6	Min. detection period required for acknowledging incoming calling signal (CI) as ON	No. 5 6 0 0 : 800 ms (1000 ms*) 0 1 : 200 ms 1 0 : 250 ms 1 1 : 150 ms
7	Line connection timing (Not used.)	0: Ringer-OFF period (default) 1: Ringer-ON period
8	Not used.	

*1000 ms in Chinese models.

- **Selectors 1 through 4: Min. detection period required for interpreting incoming calling signal (CI) as OFF**
Max. detection period for incoming calling signal (CI) being OFF

If the machine detects the OFF state of a CI signal for the period greater than the value set by selectors 1 and 2 and less than the value set by selectors 3 and 4, it interprets the CI signal as OFF.

- **Selectors 5 and 6: Min. detection period required for acknowledging incoming calling signal (CI) as ON**

These selectors set the period required to make the machine acknowledge itself to be called. That is, if the machine continuously detects a CI signal with the frequency set by selectors 1 through 4 on WSW14 during the period set by these selectors 5 and 6, then it acknowledges the call.

WSW13 (Modem setting)

Selector No.	Function	Setting and Specifications
1 2	Cable equalizer	No. 1 2 0 0 : 0 km 0 1 : 1.8 km 1 0 : 3.6 km 1 1 : 5.6 km
3 4	Reception level	No. 3 4 0 0 : -43 dBm 0 1 : -47 dBm 1 0 : -49 dBm 1 1 : -51 dBm
5 8	Modem attenuator	0: 0 dB 1: 8 dB 0: 0 dB 1: 4 dB 0: 0 dB 1: 2 dB 0: 0 dB 1: 1 dB

The modem should be adjusted according to the user's line conditions.

- **Selectors 1 and 2: Cable equalizer**

These selectors are used to improve the pass-band characteristics of analogue signals on a line. (Attenuation in the high-band frequency is greater than in the low-band frequency.) Set these selectors according to the distance from the telephone switchboard to the machine.

- **Selectors 3 and 4: Reception level**

These selectors set the optimum receive signal level.

- **Selectors 5 through 8: Modem attenuator**

These selectors are used to adjust the transmitting level attenuation of the modem when the reception level at the remote station is improper due to line loss. This function applies for G3 protocol signals.

Setting two or more selectors to "1" produces addition of attenuation assigned to each selector. If selector 8 on WSW23 is set to "0," this setting is so limited that 10 dB (1 dB in France) or higher setting only is effective. Note that in Japan and China, 9 dB or higher and 2 dB or higher settings only are effective, respectively, regardless of whether selector 8 on WSW23 is set to "0."

WSW14 (AUTO ANS facility setting)

Selector No.	Function	Setting and Specifications
1 2	Frequency band selection (lower limit) for incoming calling signal (CI)	No. 1 2 0 0 : 13 Hz 0 1 : 15 Hz 1 0 : 23 Hz 1 1 : 20 Hz
3 4	Frequency band selection (upper limit) for incoming calling signal (CI)	No. 3 4 0 0 : 30 Hz 0 1 : 55 Hz 1 0 : 70 Hz 1 1 : 200 Hz
5 8	No. of rings in AUTO ANS mode	No. 5 6 7 8 0 0 0 0 : Fixed to once 0 0 0 1 : Fixed to 2 times 0 0 1 0 : Fixed to 3 times 0 0 1 1 : Fixed to 4 times 0 1 0 0 : 1 to 2 times 0 1 0 1 : 1 to 3 times 0 1 1 0 : 1 to 4 times 0 1 1 1 : 1 to 5 times 1 0 0 0 : 2 to 3 times 1 0 0 1 : 2 to 4 times 1 0 1 0 : 2 to 5 times 1 0 1 1 : 2 to 6 times 1 1 0 0 : 1 to 10 times 1 1 0 1 : 2 to 10 times 1 1 1 0 : 3 to 5 times 1 1 1 1 : 4 to 10 times

- **Selectors 1 through 4: Frequency band selection for incoming calling signal (CI)**

These selectors are used to select the frequency band of CI for activating the AUTO ANS facility. In the French models, if the user sets the PBX to OFF from the control panel, the setting made by selectors 1 and 2 will take no effect and the frequency's lower limit will be fixed to 32 Hz. (Even if the setting made by these selectors does not apply, it will be printed on the configuration list.)

- **Selectors 5 through 8: No. of rings in AUTO ANS mode**

These selectors set the number of rings to initiate the AUTO ANS facility.

WSW15 (REDIAL facility setting)

Selector No.	Function	Setting and Specifications
1 2	Redial interval	No. 1 2 0 0 : 5 minutes 0 1 : 1 minute 1 0 : 2 minutes 1 1 : 3 minutes
3 6	No. of redialings	No. 3 4 5 6 0 0 0 0 : 16 times 0 0 0 1 : 1 times 0 0 1 0 : 2 times 0 0 1 1 : 3 times 1 1 1 1 : 15 times
7	Not used.	
8	CRP option	0: Disable 1: Enable

- **Selectors 1 through 6: Redial interval and No. of redialings**

The machine redials by the number of times set by selectors 3 through 6 at intervals set by selectors 1 and 2.

- **Selector 8: CRP option**

If a command error occurs in the machine (calling station), the machine usually waits for three seconds and then makes a retry three times. This CRP option is a request command that can be sent from the called station for requesting the calling station to retry the failed command immediately.

WSW16 (Function setting 1)

Selector No.	Function	Setting and Specifications
1	Not used.	
2	ITU-T (CCITT) superfine recommendation	0: OFF 1: ON
3 6	Not used.	
7	Max. document length limitation	0: 400 cm 1: 90 cm
8	Stop/Exit key pressed during reception	0: Not functional 1: Functional

NOTE: Selector 7 is applicable to models equipped with ADF units.

- **Selector 2: ITU-T (CCITT) superfine recommendation**

If this selector is set to "1," the machine communicates in ITU-T (CCITT) recommended superfine mode (15.4 lines/mm). If it is set to "0," it communicates in native superfine mode.

- **Selector 7: Max. document length limitation**

This selector is used to select the maximum length of a document to be sent.

- **Selector 8: Stop key pressed during reception**

If this selector is set to "1," pressing the **Stop/Exit** key can stop the current receiving operation. The received data will be lost.

WSW17 (Function setting 2)

Selector No.	Function	Setting and Specifications
1 2	Off-hook alarm	No. 1 2 0 0 : No alarm 0 1 : Always valid 1 X : Valid except when 'call reservation' is selected.
3 4	Not used.	
5	Calendar clock type	0: U.S.A. type 1: European type
6	Not used.	
7	Non-ring reception	0: OFF 1: ON
8	Not used.	

- **Selectors 1 and 2: Off-hook alarm**

These selectors activate or deactivate the alarm function which sounds an alarm when the communication is completed with the handset being off the hook.

- **Selector 5: Calendar clock type**

If this selector is set to "0" (USA), the MM/DD/YY hh:mm format applies; if it is set to "1" (Europe), the DD/MM/YY hh:mm format applies: DD is the day, MM is the month, YY is the last two digits of the year, hh is the hour, and mm is the minute.

- **Selector 7: Non-ring reception**

Setting this selector to "1" makes the machine receive calls without ringer sound if the Ring Delay is set to 0.

WSW18 (Function setting 3)

Selector No.	Function	Setting and Specifications
1	Not used.	
2 3	Detection enabled time for CNG and no tone	No. 2 3 0 0 : 40 sec. 0 1 : 0 sec. (No detection) 1 0 : 5 sec. 1 1 : 80 sec.
4 5	Not used.	
6	Registration of station ID	0: Permitted 1: Prohibited
7 8	Tone sound monitoring	No. 7 8 0 X : No monitoring 1 0 : Up to phase B at the calling station only 1 1 : All transmission phases both at the calling and called stations

- **Selectors 2 and 3: Detection enabled time for CNG and no tone**

After the line is connected via the external telephone or by picking up the handset of the machine, the machine can detect a CNG signal or no tone for the time length specified by these selectors. The setting specified by these selectors becomes effective only when selector 8 on WSW20 is set to "1."

- **Selector 6: Registration of station ID**

Setting this selector to "0" permits the registration of station ID for Austrian and Czech models.

- **Selectors 7 and 8: Tone sound monitoring**

These selectors set monitoring specifications of the tone sound inputted from the line.

WSW19 (Transmission speed setting)

Selector No.	Function	Setting and Specifications
1 3	First transmission speed choice for fallback	No. 1 2 3 No. 4 5 6 0 0 0 : 2,400 bps 0 0 1 : 4,800 bps 0 1 0 : 7,200 bps 0 1 1 : 9,600 bps 1 0 0 : 12,000 bps 1 0 1 : } 1 1 0 : } 14,400 bps 1 1 1 : }
4 6	Last transmission speed choice for fallback	
7	V.34 mode	0: Permitted 1: Prohibited
8	V.17 mode	0: Permitted 1: Prohibited

NOTE: Selector 7 takes effect only in models supporting V.34 mode.

- **Selectors 1 through 6: First and last choices of transmission speed for fallback**

These selectors are used to set the MODEM speed range. With the first transmission speed choice specified by selectors 1 through 3, the machine attempts to establish the transmission link via the MODEM. If the establishment fails, the machine automatically steps down to the next lowest speed and attempts to establish the transmission link again. The machine repeats this sequence while stepping down the transmission speed to the last choice specified by selectors 4 through 6. If the MODEM always falls back to a low transmission speed (e.g., 4,800 bps), set the first transmission speed choice to the lower one (e.g., modify it from 12,000 bps to 7,200 bps) in order to deactivate the high-speed MODEM function and reduce the training time for shorter transmission time.

Generally, to save the transmission time, set the last transmission speed choice to a higher one.

WSW20 (Overseas communications mode setting)

Selector No.	Function	Setting and Specifications
1	EP* tone prefix	0: OFF 1: ON
2	Overseas communications mode (Reception)	0: 2100 Hz 1: 1100 Hz
3	Overseas communications mode (Transmission)	0: OFF 1: Ignores DIS once.
4 5	Min. time length from reception of CFR to start of transmission of video signals	No. 4 5
		0 0 : 100 ms
		0 1 : 200 ms
		1 0 : 300 ms
		1 1 : 400 ms
6 7	At CNG detection, elimination of chattering noise (Not used)	No. 6 7
		0 0 : Yes, at both ON/OFF timings
		0 1 : Yes, at OFF timing
		1 X : No
8	Limitation on CNG detection	0: OFF 1: ON

* EP: Echo protection

NOTE: Selectors 6 and 7 are applicable to models equipped with SDAA circuits.

- **Selector 1: EP tone prefix**

Setting this selector to "1" makes the machine transmit a 1700 Hz echo protection (EP) tone immediately preceding training in V.29 modulation system to prevent omission of training signals. Prefixing an EP tone is useful when the machine fails to transmit at the V.29 modem speed and always has to fall back to 4800 bps transmission.

The setting made by this selector takes effect only when the Overseas Mode is set to ON.

- **Selectors 2 and 3: Overseas communications mode**

These selectors should be used if the machine malfunctions in overseas communications.

According to the communications error state, select the signal specifications.

Setting selector 2 to "1" allows the machine to use 1100 Hz CED signal instead of 2100 Hz in receiving operation. This prevents malfunctions resulting from echoes, since the 1100 Hz signal does not disable the echo suppressor (ES) while the 2100 Hz signal does.

Setting selector 3 to "1" allows the machine to ignore a DIS signal sent from the called station once in sending operation. This operation suppresses echoes since the first DIS signal immediately follows a 2100 Hz CED (which disables the ES) so that it is likely to be affected by echoes in the disabled ES state. However, such a disabled ES state will be removed soon so that the second and the following DIS signals are not susceptible to data distortion due to echoes. Note that some models when called may cause error by receiving a self-outputted DIS.

The setting made by selector 3 takes effect only when the Overseas Communications Mode is set to ON. (The setting made by selector 2 is always effective.)

- **Selectors 8: Limitation on CNG detection**

If this selector is set to "1," the machine detects a CNG signal according to the condition preset by selectors 2 and 3 on WSW18 after a line is connected. If it is set to "0," the machine detects a CNG signal as long as the line is connected.

WSW21 (TAD setting 1)

Selector No.	Function	Setting and Specifications
1 5	Max. waiting time for voice signal	No. 1 2 3 4 5 0 0 0 0 0 : No detection 0 0 0 0 1 : 1 sec. 0 0 0 1 0 : 2 sec. 0 0 0 1 1 : 3 sec. 0 1 0 0 0 : 8 sec. 1 1 1 1 1 : 31 sec.
6 7	Taping the call	No. 6 7 0 0 : Enable (signaling for U.S.A.) 0 1 : Enable (signaling for countries except U.S.A.) 1 0 : Enable (without signaling) 1 1 : Disable
8	Erasure of message stored in the memory after the message transfer	0: Yes 1: No

NOTE: Selectors 1 through 5 are applicable to models equipped with ICM recorders.

NOTE: Selectors 6 and 7 are applicable to models with internal TADs.

NOTE: Selector 8 is applicable to models equipped with TADs.

- **Selectors 1 through 5: Max. waiting time for voice signal**

In the TAD mode, the machine waits for voice signal for the time length specified by these selectors before it automatically shifts to the facsimile message receive mode or disconnects the line.

- **Selectors 6 and 7: Taping the call**

These selectors select whether or not to tape the call. Setting them to "1, 0" enables taping the call without signaling to the calling station that the call is being taped.

- **Selector 8: Erasure of message stored in the memory after the message transfer**

Setting this selector to "0" will erase the message recorded in the memory after the document retrieval feature transfers the message.

WSW22 (ECM and call waiting caller ID)

Selector No.	Function	Setting and Specifications	
1	ECM* in sending	0: ON	1: OFF
2	ECM* in receiving	0: ON	1: OFF
3	Call Waiting Caller ID	0: ON	1: OFF
4	Not used.		
5	Acceptable TCF bit error rate (%) (Only at 4800 bps) (Not used.)	0: 0%	1: 8%
		0: 0%	1: 4%
8		0: 0%	1: 2%
		0: 0%	1: 1%

* ECM: Error correction mode

NOTE: Selector 3 is applicable to the American models only.

NOTE: Selectors 5 through 8 are applicable to the Chinese, Taiwanese and Asian models only.

- **Selector 3: Call Waiting Caller ID**

Setting this selector to "0" allows the user to decide whether or not to interrupt the current call when a new call comes in. If Call Waiting Caller ID service is available in the area and the user subscribes to it, he/she can see information about his/her incoming call on the LCD.

- **Selectors 5 through 8: Acceptable TCF bit error rate (%) (Not used.)**

Setting two or more selectors to "1" produces addition of percent assigned to each selector. If you set selectors 7 and 8 to "1," the acceptable TCF bit error rate will be 3%.

WSW23 (Communications setting)

Selector No.	Function	Setting and Specifications
1	Starting point of training check (TCF)	0: From the head of a series of zeros 1: From any arbitrary point
2 3	Allowable training error rate	No. 2 3 0 0 : 0% 0 1 : 0.5% 1 0 : 1% 1 1 : 2%
4 5		No. 4 5 0 0 : 16% 0 1 : 14% 1 0 : 10% 1 1 : 8%
6 7	Not used.	
8	Limitation of attenuation level	0: Yes 1: No

NOTE: Selector 8 is not applicable to the French models.

- **Selector 1: Starting point of training check (TCF)**

At the training phase of receiving operation, the called station detects for 1.0 second a training check (TCF) command, a series of zeros which is sent from the calling station for 1.5 seconds to verify training and give the first indication of the acceptability of the line.

This selector sets the starting point from which the called station should start counting those zeros. If this selector is set to "0," the called station starts counting zeros 100 ms after the head of a series of zeros is detected.

If it is set to "1," the called station starts counting zeros upon detection of 10-ms successive zeros 50 ms after the head of a series of zeros is detected. In this case, if the detection of 10-ms successive zeros is too late, the data counting period will become less than 1.0 second, making the called station judge the line condition unacceptable.

- **Selectors 2 and 3: Allowable training error rate**

The called station checks a series of zeros gathered in training (as described in Selector 1) according to the allowable training error rate set by these selectors. If the called station judges the line condition to be accepted, it responds with CFR; if not, it responds with FTT.

- **Selectors 4 and 5: Decoding error rate for transmission of RTN**

The machine checks the actual decoding errors and then transmits an RTN according to the decoding error rate (Number of lines containing an error per page ÷ Total number of lines per page) set by these selectors.

- **Selector 8: Limitation of attenuation level**

Setting this selector to "0" limits the transmitting level of the modem to 10 dB (1 dB in France).

This setting has priority over the settings selected by WSW02 (selectors 5 through 8) and WSW13 (selectors 5 through 8).

WSW24 (TAD setting 2)

Selector No.	Function	Setting and Specifications
1 2	Maximum OGM recording time	No. 1 2 0 0 : 15 sec. 0 1 : 20 sec. 1 0 : 30 sec. 1 1 : 50 sec.
3 4	Time length from CML ON to start of pseudo ring backtone transmission	No. 3 4 0 0 : 4 sec. 0 1 : 3 sec. 1 0 : 2 sec. 1 1 : 1 sec.
5 8	Attenuator for playback of ICM/OGM to the line (Selectable from the range of 0-15 dB)	0: 0 dB 1: 8 dB 0: 0 dB 1: 4 dB 0: 0 dB 1: 2 dB 0: 0 dB 1: 1 dB

- **Selectors 1 and 2: Maximum OGM recording time**

These selectors set the allowable maximum recording time for an OGM.

- **Selectors 3 and 4: Time length from CML ON to start of pseudo ring backtone transmission**

These selectors set the length of time from CML-ON up to the start of pseudo ring backtone transmission.

In models with OGM facilities, the settings made by these selectors also apply to the length of time from CML-ON up to the start of OGM transmission.

- **Selectors 5 through 8: Attenuator for playback of ICM/OGM to the line**

Setting two or more selectors to "1" produces addition of attenuation assigned to each selector. This setting is not limited by selector 8 on WSW23.

WSW25 (TAD setting 3)

Selector No.	Function	Setting and Specifications																																																						
1 4	Not used.																																																							
5 7	Pause between paging number and PIN	<table> <tr> <td>No.</td> <td>5</td> <td>6</td> <td>7</td> <td></td> <td></td> </tr> <tr> <td></td> <td>0</td> <td>0</td> <td>0</td> <td>:</td> <td>2 sec.</td> </tr> <tr> <td></td> <td>0</td> <td>0</td> <td>1</td> <td>:</td> <td>4 sec.</td> </tr> <tr> <td></td> <td>0</td> <td>1</td> <td>0</td> <td>:</td> <td>6 sec.</td> </tr> <tr> <td></td> <td>0</td> <td>1</td> <td>1</td> <td>:</td> <td>8 sec.</td> </tr> <tr> <td></td> <td>1</td> <td>0</td> <td>0</td> <td>:</td> <td>10 sec.</td> </tr> <tr> <td></td> <td>1</td> <td>0</td> <td>1</td> <td>:</td> <td>12 sec.</td> </tr> <tr> <td></td> <td>1</td> <td>1</td> <td>0</td> <td>:</td> <td>14 sec.</td> </tr> <tr> <td></td> <td>1</td> <td>1</td> <td>1</td> <td>:</td> <td>16 sec.</td> </tr> </table>	No.	5	6	7				0	0	0	:	2 sec.		0	0	1	:	4 sec.		0	1	0	:	6 sec.		0	1	1	:	8 sec.		1	0	0	:	10 sec.		1	0	1	:	12 sec.		1	1	0	:	14 sec.		1	1	1	:	16 sec.
No.	5	6	7																																																					
	0	0	0	:	2 sec.																																																			
	0	0	1	:	4 sec.																																																			
	0	1	0	:	6 sec.																																																			
	0	1	1	:	8 sec.																																																			
	1	0	0	:	10 sec.																																																			
	1	0	1	:	12 sec.																																																			
	1	1	0	:	14 sec.																																																			
	1	1	1	:	16 sec.																																																			
8	Not used.																																																							

NOTE: Selectors 5 through 7 are applicable to the U.S.A. models only.

- **Selectors 5 through 7: Pause between paging number and PIN**

These selectors set the pause time between a telephone number being paged and PIN (personal identification number) for the paging feature.

WSW26 (Function setting 4)

Selector No.	Function	Setting and Specifications
1 2	Not used.	
3	Dialing during document reading into the temporary memory in in-memory message transmission	0: Disable 1: Enable
4 5	No. of CNG cycles to be detected (when the line is connected via the external telephone except in the external TAD mode or via the built-in telephone)	No.4 5 0 0 : 0.5 (A) 0 1 : 1 (B) 1 0 : 1.5 (C) 1 1 : 2 (D)
6 7	No. of CNG cycles to be detected (when the line is connected via the external telephone in the external TAD mode, via the built-in telephone in the TAD mode, or via the machine in the automatic reception of the F/T mode)	No.6 7 0 0 : 0.5 (A) 0 1 : 1 (B) 1 0 : 1.5 (C) 1 1 : 2 (D)
8	Not used.	

- **Selector 3: Dialing during document reading into the temporary memory in in-memory message transmission**

If this selector is set to "0," the machine waits for document reading into the memory to complete and then starts dialing. This enables the machine to list the total number of pages in the header of the facsimile message.

- **Selectors 4 and 5: No. of CNG cycles to be detected (when the line is connected via the external telephone except in the external TAD mode or via the built-in telephone)**

The machine interprets a CNG as an effective signal if it detects the CNG by the number of cycles specified by these selectors when the line is connected via the external telephone except in the external TAD mode or via the built-in telephone.

- **Selectors 6 and 7: No. of CNG cycles to be detected (when the line is connected via the external telephone in the external TAD mode, via the built-in telephone in the TAD mode, or via the machine in the automatic reception of the F/T mode)**

The machine interprets a CNG as an effective signal if it detects the CNG by the number of cycles specified by these selectors when the line is connected via the external telephone in the external TAD mode, via the built-in telephone in the TAD mode, or via the machine in the automatic reception of the F/T mode.

WSW27 (Function setting 5)

Selector No.	Function	Setting and Specifications	
1	Not used.		
2	Ringer OFF setting	0: Yes	1: No
3	Automatic playback of OGM when switched to the TAD mode	0: No	1: Yes
4	Detection of distinctive ringing pattern (Not used.)	0: Yes	1: No
5			
6	Recording quality	0: Normal	1: High
7	Recording time for high recording quality	0: Short (9.6 kbps)	1: Long (8.8 kbps)
8	Not used.		

NOTE: Selectors 4 and 5 are applicable to the U.S.A. models only.

- **Selector 2: Ringer OFF setting**

This selector determines whether or not the ringer can be set to OFF.

- **Selector 3: Automatic playback of OGM when switched to the TAD mode**

This selector determines whether or not to automatically play back an OGM the moment the machine switches to the TAD mode.

- **Selectors 4 and 5: Detection of distinctive ringing pattern (Not used.)**

If this selector is set to "1," the machine detects only the number of rings; if it is set to "0," the machine detects the number of rings and the ringing time length to compare the detected ringing pattern with the registered distinctive one.

- **Selector 6: Recording quality**

This selector determines the recording quality for the OGM and ICM. Selecting "1" (High) increases the quality, sacrificing the recording time.

- **Selector 7: Recording time for high recording quality**

This setting takes effect when selector 6 is set to "1" (High). Setting this selector to "0" (Short) further increases the recording quality, sacrificing the recording time.

The recording quality and time to be applied when this selector is set to "1" (Long) are higher and shorter than the ones to be applied when selector 6 is set to "0" (Normal).

The recording quality and time determined by this selector being set to "1" (Long) are higher and shorter than the ones determined by selector 6 being set to "0" (Normal).

WSW28 (Function setting 6)

Selector No.	Function	Setting and Specifications
1 3	Transmission level of DTMF high-band frequency signal	No. 1 2 3 0 0 0 : 0 dB 0 0 1 : +1 dB 0 1 0 : +2 dB 0 1 1 : +3 dB 1 0 0 : 0 dB 1 0 1 : -1 dB 1 1 0 : -2 dB 1 1 1 : -3 dB
4 6	Transmission level of DTMF low-band frequency signal	No. 4 5 6 0 0 0 : 0 dB 0 0 1 : +1 dB 0 1 0 : +2 dB 0 1 1 : +3 dB 1 0 0 : 0 dB 1 0 1 : -1 dB 1 1 0 : -2 dB 1 1 1 : -3 dB
7 8	Not used.	

- Selectors 1 through 6: Transmission level of DTMF high-/low-band frequency signal**

These selectors are intended for the manufacturer who tests the machine for the Standard. Never access them.

WSW29 (Function setting 7)

Selector No.	Function	Setting and Specifications
1 3	Compression threshold level for voice signals inputted via the telephone line in the built-in TAD operation	No. 1 2 3 0 0 0 : -47.0 dBm (A) 0 0 1 : -48.5 dBm (B) 0 1 0 : -50.0 dBm (C) 0 1 1 : -51.5 dBm (D) 1 0 0 : -53.0 dBm (E) 1 0 1 : -54.5 dBm (F) 1 1 0 : -56.0 dBm (G) 1 1 1 : OFF (H)
4 6	Compression threshold level for voice signals inputted via the handset in the built-in TAD operation	No. 4 5 6 0 0 0 : -44.0 dBm (A) 0 0 1 : -45.5 dBm (B) 0 1 0 : -47.0 dBm (C) 0 1 1 : -48.5 dBm (D) 1 0 0 : -50.0 dBm (E) 1 0 1 : -51.5 dBm (F) 1 1 0 : -53.0 dBm (G) 1 1 1 : OFF (H)
7	Impedance switching control in pulse dialing	0: OFF 1: ON
8	Prompt beep when the memory area for the activity report becomes full	0: No 1: Yes

NOTE: Selectors 1 through 6 are applicable to models equipped with built-in TADs.

NOTE: Selectors 7 and 8 are applicable only to the European versions.

- **Selectors 1 through 6: Compression threshold level for voice signals inputted via the telephone line in the built-in TAD operation**

If voice signals inputted via the telephone line are below the level specified by these selectors, the TAD interprets those received voice signals as no signal, compressing the recording time.

- **Selector 8: Prompt beep for activity report**

This selector determines whether or not to beep if the memory area for the activity report becomes full, for prompting you to print out the report. (Printing it out will clear the memory area.)

WSW30 (Function setting 8)

Selector No.	Function	Setting and Specifications
1 3	Dial tone/busy tone detection level during recording of ICM (Not used.)	No. 1 2 3 0 0 0 : -38.0 dBm (A) 0 0 1 : -39.5 dBm (B) 0 1 0 : -41.0 dBm (C) 0 1 1 : -42.5 dBm (D) 1 0 0 : -44.0 dBm (E) 1 0 1 : -45.5 dBm (F) 1 1 0 : -47.0 dBm (G) 1 1 1 : -48.5 dBm (H)
4 7	Not used.	
8	Text copy density adjustment	0: Normal 1: Dark

NOTE: Selectors 1 through 3 are applicable to models equipped with internal TADs.

- **Selectors 1 through 3: Dial tone/busy tone detection level during recording of ICM (Not used.)**

If the machine (called station) detects dial tone (400 Hz continuously) or busy tone (400 Hz intermittently) exceeding the detection level specified by these selectors for the period specified by selectors 1 through 4 on WSW35, then it interprets the calling station as being disconnected. The machine stops TAD recording and disconnects the line.

- **Selectors 8: Text copy density adjustment**

This function is used when a copied image of a dark document is still light even if adjusting using the contrast adjustment for the user operation.

WSW31 (Function setting 9)

Selector No.	Function	Setting and Specifications
1	Not used.	
2	Default reduction rate for failure of automatic reduction during recording	0: 100% 1: 70%
3	Not used.	
4	(Do not disturb this selector.)	
5	Minimum ON and OFF duration of ringer signals effective in distinctive ringing	0: 130 ms 1: 90 ms
6 8	Not used.	

NOTE: Selector 5 is applicable only to the U.S.A. models.

- **Selector 2: Default reduction rate for failure of automatic reduction during recording**

This selector sets the default reduction rate to be applied if the automatic reduction function fails to record one-page data sent from the calling station in a single page of the current recording paper. If it is set to "0," the machine records one-page data at full size (100%) without reduction; if it is set to "1," the machine records it at 70% size.

- **Selector 5: Minimum ON and OFF duration of ringer signals effective in distinctive ringing**

The ringer pattern consists of short and long rings, e.g., short-short-long rings. This selector sets the minimum ON and OFF duration of ringer signals that are required for the machine to interpret ringer signals as being ON or OFF. This is to prevent components of a ringer pattern from being misinterpreted due to chattering in distinctive ringing.

The machine monitors ringer signals at 10-ms intervals. If the signal is ON, the machine counts +1; if it is OFF, it counts -1. If the counter increments up to +5 or +13 when this selector is set to "1" (50 ms) or "0" (130 ms), respectively, the machine interprets the current signal as being ON. If the counter returns to zero, the machine interprets the signal as being OFF. If the Distinctive Ring is set to OFF, this selector is not effective.

WSW32 (Function setting 10)

Selector No.	Function	Setting and Specifications
1 4	Not used.	
5 6	Default resolution	No. 5 6 0 0 : Standard 0 1 : Fine 1 0 : Super fine 1 1 : Photo
7 8	Default contrast	No. 7 8 0 X : Automatic 1 0 : Super light 1 1 : Super dark

- **Selectors 5 and 6: Default resolution**

These selectors set the default resolution which applies when the machine is turned on or completes a transaction.

- **Selectors 7 and 8: Default contrast**

These selectors set the default contrast which applies when the machine is turned on or completes a transaction.

WSW33 (Function setting 11)

Selector No.	Function	Setting and Specifications
1 3	Detection threshold level of "no tone" during recording of ICM	No. 1 2 3 0 0 0 : -42.5 dBm (A) 0 0 1 : -44.0 dBm (B) 0 1 0 : -45.5 dBm (C) 0 1 1 : -47.0 dBm (D) 1 0 0 : -48.5 dBm (E) 1 0 1 : -50.0 dBm (F) 1 1 0 : -51.5 dBm (G) 1 1 1 : -53.0 dBm (H)
4 5	FAX receiving speed to be kept within the transmission speed limit to the PC	No. 4 5 0 0 : 14,400 bps 0 1 : 12,000 bps 1 0 : 9,600 bps 1 1 : 7,200 bps
6	Report output of polled transmission requests	0: Yes 1: No
7 8	Comfortable noise level (Not used.)	No. 7 8 0 0 : OFF 0 1 : Low (A) 1 0 : Medium (B) 1 1 : High (C)

NOTE: Selectors 1 through 3 are applicable to models equipped with internal TADs.

- **Selectors 1 through 3: Detection threshold level of "no tone" during recording of ICM**

If the tone level during recording of ICM is less than the threshold setting made by these selectors, the tone is interpreted as "no tone. " When the "no tone" state is kept for the period specified by selectors 1 through 5 on WSW21, the machine disconnects the line.

- **Selectors 4 and 5: FAX receiving speed to be kept within the transmission speed limit to the PC**

To transmit FAX data being received from other machine to the connected PC, you may need to keep the FAX receiving speed within the transmission speed limit specified for the PC. In an initial negotiation sequence for transmission, the machine responds to the calling station with the allowable FAX receiving speed specified by these selectors.

- **Selectors 7 and 8: Comfortable noise level (Not used.)**

These selectors set the level of noise to be added during playing-back of voice signals recorded with no-signal compression.
 If they are set to "0, 0," no noise will be added.

WSW34 (Function setting 12)

Selector No.	Function	Setting and Specifications
1 3	Erasing time length of ICM tone recorded preceding the tone detection starting point in the case of automatic line disconnection due to no voice signal received	No. 1 2 3 0 0 0 : 0 sec. 0 0 1 : 1 sec. 0 1 0 : 2 sec. 0 1 1 : 3 sec. 1 0 0 : 4 sec. 1 0 1 : 5 sec. 1 1 0 : 6 sec. 1 1 1 : 7 sec.
4 5	No. of CNG cycles to be detected (when the line is connected via the external telephone in the external TAD mode or via the machine in F/T mode)	No. 4 5 0 0 : 0.5 (A) 0 1 : 1 (B) 1 0 : 1.5 (C) 1 1 : 2 (D)
6 7	Number of DTMF tone signals for inhibiting the detection of CNG during external TAD operation	No. 6 7 0 0 : 3 0 1 : 2 1 0 : 1 1 1 : OFF
8	Not used.	

NOTE: Selectors 1 through 5 are applicable to models equipped with built-in TADs.

- **Selectors 1 through 3: Erasing time length of ICM tone recorded preceding the tone detection starting point in the case of automatic line disconnection due to no voice signal received**

If the machine has disconnected the line after detection of disconnection tone in ICM recording, it erases tone recorded preceding the tone detection starting point for the time length set by these selectors.

- **Selectors 4 and 5: No. of CNG cycles to be detected (when the line is connected via the external telephone in the external TAD mode or via the machine in F/T mode)**

The machine interprets a CNG as an effective signal if it detects a CNG signal by the number of cycles specified by these selectors when the line is connected via the external telephone in the external TAD mode or via the machine in F/T mode.

- **Selectors 6 and 7: Number of DTMF tone signals for inhibiting the detection of CNG during external TAD operation**

If the machine receives this specified number of DTMF tone signals during external TAD operation, it will not detect CNG afterwards.

If these selectors are set to "1, 1," the CNG detection will not be inhibited.

WSW35 (Function setting 13)

Selector No.	Function	Setting and Specifications
1 4	Max. detection period of dial tone/busy tone during recording of ICM	No. 1 2 3 4 0 0 0 0 : No detection 0 0 0 1 : 1 sec. 0 0 1 0 : 2 sec. 0 1 0 0 : 4 sec. 1 1 1 1 : 15 sec.
5 8	Not used.	

NOTE: Selectors 1 through 4 are applicable to models equipped with internal TADs.

- **Selectors 1 through 4: Max. detection period of dial tone/busy tone during recording of ICM**

If the machine (called station) detects dial tone or busy tone exceeding the detection level specified by selectors 1 through 3 on WSW30 for the period specified by these selectors, then it disconnects the line.

WSW36 (Function setting 14)

Selector No.	Function	Setting and Specifications
1	ECP mode* (Not used.)	0: ON 1: OFF
2	Recovery from Inactive PC Interface (Not used.)	0: Disable 1: Enable
3	PC Power-off Recognition Time (Not used.)	0: Normal 1: Long
4	Not used.	
5	Escape from phase C	0: Yes 1: No
6 8	Extension of incoming calling signal (CI) frequency band specified by selectors 1 through 4 on WSW14	No. 6 7 8 0 0 0 : 0 (Ignored) 0 0 1 : 4 (448 Hz) 0 1 0 : 8 (244 Hz) 0 1 1 : 12 (162 Hz) 1 0 0 : 16 (122 Hz) 1 0 1 : 20 (97 Hz) 1 1 0 : 24 (81 Hz) 1 1 1 : 28 (69 Hz)

*ECP (Enhanced Capabilities Port)

- **Selector 1: ECP mode (Not used.)**

The ECP mode enhances the normal bidirectional communications between the machine and the connected PC for higher transmission speed.

- **Selector 2: Recovery from Inactive PC Interface (Not used.)**

If the machine recognizes via the STB signal line that the connected PC is powered off, it will turn the PC interface outputs Low to protect the PC from hazards that could be caused by weak electric current accidentally flown from the machine.

This selector determines whether or not the machine should recover from the inactive PC interface to normal interfacing state upon receipt of data from the PC.

- **Selector 3: PC Power-off Recognition Time (Not used.)**

This selector sets the time length from when the machine detects the PC powered off until it recognizes the detected state as power-off.

If selector 2 is set to "0," it is recommended that selector 3 be set to "1"; otherwise, the machine may mistakenly detect PC powered off.

- **Selector 5: Escape from phase C**

This selector determines whether or not the machine will escape from phase C when it detects an RTC (Return to Control) in non-ECM mode or an RCP (Return to Control Partial page) in ECM mode.

- **Selectors 6 through 8: Extension of incoming calling signal (CI) frequency band specified by selectors 1 through 4 on WSW14**

At the start of reception, if the machine detects the frequency of a CI signal specified by selectors 1 through 4 on WSW14, it starts the ringer sounding. However, the machine may fail to detect the CI signal normally due to noise superimposed at the time of reception. To prevent it, use selectors 6 through 8 on WSW36.

If the machine detects higher frequencies than the setting made here, it regards them as noise and interprets the detecting state as being normal, allowing the ringer to keep sounding according to the preset number of ringers (until it starts automatic reception of FAX data in the FAX mode or enters the TAD mode in the TEL mode).

WSW37 (Function setting 15)

Selector No.	Function	Setting and Specifications
1	Printout of the stored image data of an unsent document onto an error report	0: No 1: Yes
2	Erasure of the stored image data of an unsent document at the time of the subsequent in-memory message transmission	0: No 1: Yes
3 8	Not used.	

- **Selector 1: Printout of the stored image data of an unsent document onto an error report**

This selector determines whether or not to print out the 1st-page image data of a document onto the error report if the document image data stored in the temporary memory cannot be transmitted normally.

- **Selector 2: Erasure of the stored image data of an unsent document at the time of the subsequent in-memory message transmission**

If in-memory message transmission fails repeatedly when selector 1 is set to "1," the temporary memory will be occupied with image data. Setting selector 2 to "1" will automatically erase the stored 1st-page image data of an unsent document at the time of the subsequent in-memory message transmission only when recording paper or toner runs out.

WSW38 (V.34 transmission settings)

Selector No.	Function	Setting and Specifications
1 2	Setting of the equalizer	No. 1 2 0 X : Automatic 1 0 : Fixed to 4 points 1 1 : Fixed to 16 points
3	Sending level of guard tone at phase 2	0: Normal - 7 db 1: Normal
4	Stepping down the transmission speed at fallback each	0: 2400 bps 1: 4800 bps
5 6	Automatic control of modem's EQM gain for proper transmission speed choice	No. 5 6 0 0 : For higher transmission speed than the current setting 0 1 : No change from the current setting 1 0 : For lower transmission speed than the current setting 1 1 : For further lower transmission than the setting made by 1, 0
7	Redialing when a communications error occurs	0: ON 1: OFF
8	Detection of CED for stopping CNG	0: ON 1: OFF

NOTE: WSW38 takes effect only when the V.34 mode is permitted (WSW19, selector 7) in models supporting V.34 mode.

- **Selectors 1 and 2: Setting of the equalizer**

These selectors set the equalizer's training level to be applied if the machine fails to send training due to weak line connection. If these selectors are set to "0, X," the modem will automatically set the appropriate training level.

- **Selector 3: Sending level of guard tone at phase 2**

This selector sets the sending level of guard tone for 1800 Hz to be sent at Phase 2 in the V. 34 mode.

- **Selector 4: Stepping down the transmission speed at fallback each**

This selector determines how much the modem steps down the transmission speed at fallback when called by the remote station. If this selector is set to "1," the modem may step down the transmission speed from 33600 bps to 28800 bps by one-time fallback.

- **Selectors 5 and 6: Automatic control of modem's EQM gain for proper transmission speed choice**

These selectors determine how the modem controls the EQM (Eye Quality Monitor) gain for proper choice of the transmission speed, which applies if the modem selects higher transmission speed than the possible speed so that it always repeats falling back.

- **Selector 8: Detection of CED for stopping CNG**

If this selector is set to "0," the detection time of CED specified by WSW43, selectors 4 and 5 will apply.

WSW39 (V.34 transmission speed)

Selector No.	Function	Setting and Specifications
1 4	First transmission speed choice for fallback	No. 1 2 3 4 No. 5 6 7 8
		0 0 0 0 : 2400 bps
		0 0 0 1 : 4800 bps
		0 0 1 0 : 7200 bps
		0 0 1 1 : 9600 bps
		0 1 0 0 : 12000 bps
		0 1 0 1 : 14400 bps
		0 1 1 0 : 16800 bps
5 8	Last transmission speed choice for fallback	0 1 1 1 : 19200 bps
		1 0 0 0 : 21600 bps
		1 0 0 1 : 24000 bps
		1 0 1 0 : 26400 bps
		1 0 1 1 : 28800 bps
		1 1 0 0 : 31200 bps
		1 1 0 1 : 33600 bps
		1 1 1 0 : 33600 bps
1 1 1 1 : 33600 bps		

NOTE: WSW39 takes effect only when the V.34 mode is permitted (WSW19, selector 7) in models supporting V.34 mode. For the transmission speed setting in other modes, refer to WSW19.

• **Selectors 1 through 8: First and last choices of transmission speed for fallback**

These selectors are used to set the modem speed range. With the first transmission speed choice specified by selectors 1 through 4, the machine attempts to establish the transmission link via the modem. If the establishment fails, the machine automatically steps down to the next highest speed and attempts to establish the transmission link again. The machine repeats this sequence while stepping down the transmission speed to the last choice specified by selectors 5 through 8. If the modem always falls back to a low transmission speed (e.g., 24,000 bps), set the first transmission speed choice to the lower one (e.g., modify it from 31,200 bps to 26,400 bps) in order to deactivate the high-speed modem function and reduce the training time for shorter transmission time.

WSW39 will be limited by selectors 3 through 8 on WSW40.

WSW40 (V.34 modem settings)

Selector No.	Function	Setting and Specifications			
1 2	Not used.				
3 8	Masking of symbol rate(s)		Not masking	Masking	
		No. 3	0	1	3429 symbols/sec
		No. 4	0	1	3200 symbols/sec
		No. 5	0	1	3000 symbols/sec
		No. 6	0	1	2800 symbols/sec
		No. 7	-	-	Not used.
No. 8	0	1	2400 symbols/sec		

NOTE: WSW40 takes effect only when the V.34 mode is permitted (WSW19, selector 7) in models supporting V.34 mode.

- **Selectors 3 through 8: Masking of symbol rate(s)**

These selectors allow you to limit the transmission speed range in V.34 mode by masking the desired symbol rate(s). Transmission speeds assigned to the symbol rates are listed on the next page. The setting made by these selectors will limit the setting made by selectors 1 through 4 on WSW39.

If selector 3 is set to "1" to mask the 3429 symbols/second when the first transmission speed choice is 33600 bps (specified by selectors 1 through 4 of WSW39), for example, then the allowable maximum transmission speed will be limited to 31200 bps. If selector 8 is set to "1" to mask the 2400 symbols/second when the first transmission speed choice is 33600 bps, then the allowable maximum transmission speed remains 33600 bps.

If selector 8 is set to "1" to mask the 2400 symbols/second when the first transmission speed choice is 21600 bps (specified by selectors 1 through 4 on WSW39), then the allowable maximum transmission speed remains 21600 bps but the minimum transmission speed will be limited to 4800 bps.

Symbol rate	Transmission speed (bps)	Symbol rate	Transmission speed (bps)	Symbol rate	Transmission speed (bps)
2400	2400	3000	4800	3429	4800
	4800		7200		7200
	7200		9600		9600
	9600		12000		12000
	12000		14400		14400
	14400		16800		16800
	16800		19200		19200
	19200		21600		21600
	21600		24000		24000
	21600		26400		28800
2800	4800	3200	4800	3429	31200
	7200		7200		33600
	9600		9600		
	12000		12000		
	14400		14400		
	16800		16800		
	19200		19200		
	21600		21600		
	24000		24000		
	26400		26400		
			28800		
			31200		

WSW41 (ON-duration of the scanning light source)

Selector No.	Function	Setting and Specifications
1 3	ON-duration of the scanning light source at room temperature (Not used.)	No. 1 2 3 0 0 0 : 16 hours 0 0 1 : 24 hours 0 1 0 : 12 hours 0 1 1 : 8 hours 1 0 0 : 4 hours 1 0 1 : 2 hours 1 1 0 : 10 minutes 1 1 1 : 0 minute
4	Not used.	
5 8	Modem attenuator	No. 5 6 7 8 0 0 0 0 : -10 dBm 0 0 0 1 : -11 dBm 0 0 1 0 : -12 dBm 0 0 1 1 : -13 dBm 0 1 0 0 : -14 dBm 1 1 1 1 : -25 dBm

- **Selectors 1 through 3: ON-duration of the scanning light source at room temperature (Not used.)**

If the scanning operation is started when the scanning light source is off, then it will come on for scanning. These selectors determine how long the light source is ON after scanning. If these selectors are set to "1, 1, 1," the light source goes off immediately after the scanning sequence.

- **Selectors 5 through 8: Modem attenuator**

These selectors are used to adjust the transmitting level of the modem when the reception level at the remote station is improper due to line loss. This function applies to super G3 protocol signals.

WSW42 (Internet mail settings)

Selector No.	Function	Setting and Specifications
1	Access to the incoming mail (POP3) server (Periodical or on-demand)	0: Disable 1: Enable
2	Access to the outgoing mail (SMTP) server	0: Disable 1: Enable
3	I-FAX relay	0: Disable 1: Enable
4 8	Not used.	

NOTE: WSW42 is applicable to models equipped with LAN interface.

WSW43 (Function setting 21)

Selector No.	Function	Setting and Specifications
1	Not used.	
2 3	Wait time for PC-Fax reception (Class 2) and FPTS command transmission	No. 2 3 0 0 : 50 ms 0 1 : 100 ms 1 0 : 150 ms 1 1 : 0 ms
4 5	Detection time of 2100 Hz CED or ANSam	No. 4 5 0 0 : 200 ms 0 1 : 300 ms 1 0 : 400 ms 1 1 : 500 ms
6	Not used.	
7	Automatic start of remote maintenance	0: No 1: Yes
8	JPEG coding	0: Disable 1: Enable

- **Selector 8: JPEG coding**

Setting this selector to "0" disables the machine from sending/receiving JPEG color images and from receiving JPEG monochrome images.

WSW44 (Speeding up scanning-1)

Selector No.	Function	Setting and Specifications
1 5	Not used.	
6 8	Effective time length of the white level compensation data obtained beforehand (Not used.)	No. 6 7 8 0 0 0 : Obtained compensation data ineffective 0 0 1 : 1 min. 0 1 0 : 3 min. 0 1 1 : 5 min. 1 0 0 : 10 min. 1 0 1 : 15 min. 1 1 0 : 20 min. 1 1 1 : 30 min.

NOTE: Selectors 6 through 8 are applicable only to models equipped with ADF units.

- **Selectors 6 through 8: Effective time length of the white level compensation data obtained beforehand (Not used.)**

If you set documents in the ADF and the document front sensor detects them, the controller will make correction of the reference voltage to be applied to white level compensation for document scanning before the **Copy** key is pressed.

These selectors determine how long compensation data obtained beforehand will keep effective.

WSW45 (Speeding up scanning-2)

Selector No.	Function	Setting and Specifications
1 3	Delay time from when documents are set until the ADF starts drawing them in (Not used.)	No. 1 2 3 0 0 0 : No automatic drawing-in 0 0 1 : 1 sec. 0 1 0 : 2 sec. 0 1 1 : 3 sec. 1 0 0 : 4 sec. 1 0 1 : 5 sec. 1 1 0 : 6 sec. 1 1 1 : 7 sec.
4 6	Periodical correction intervals of the reference voltage to be applied to white level compensation for document scanning, during standby (Not used.)	No. 4 5 6 0 0 0 : No correction of reference voltage during standby 0 0 1 : 10 sec. 0 1 0 : 30 sec. 0 1 1 : 1 min. 1 0 0 : 3 min. 1 0 1 : 5 min. 1 1 0 : 10 min. 1 1 1 : 30 min.
7	Standby position of the CIS unit (Not used.)	0: CIS home position 1: Location of the white-level reference film
8	Not used.	

NOTE: WSW45 is applicable only to models equipped with ADF units.

- **Selectors 1 through 3: Delay time from when documents are set until the ADF starts drawing them in (Not used.)**

These selectors determine how long the ADF will delay automatic drawing-in of documents (to the scanning standby position) after you set them in the ADF, as well as determining whether or not the ADF automatically draws in documents.

- **Selectors 4 through 6: Periodical correction intervals of the reference voltage applied to white level compensation for document scanning, during standby (Not used.)**

These selectors set the correction intervals (in seconds) of the reference voltage to be applied to white level compensation for document scanning during standby, as well as determining whether or not the controller makes the reference voltage correction during standby. (Conventionally, the correction has been made immediately before the start of actual scanning)

This function takes effect in copying. Making the correction during standby may shorten the preparation time for copying.

NOTE: Do not access these selectors.

- **Selector 7: Standby position of the CIS unit (Not used.)**

This selector determines whether the standby position of the CIS unit should be the home position or the location of the white-level reference film (attached to the inside of the scanner top cover). If the location of the reference film is selected, the CIS unit will not return to the home position so as to shorten the travel time, decreasing the preparation time for copying.

WSW46 (Monitor of power ON/OFF state and parallel port kept at high)

Selector No.	Function	Setting and Specifications
1 2	Monitoring the PC ON/OFF state (Not used.)	No. 1 2 0 0 : Disable 0 1 : Monitor SELECT IN 1 0 : Monitor STROBE 1 1 : Monitor both SELECT IN and STROBE
3	Parallel port output pins kept at high level (Not used.)	0: Enable 1: Disable
4	Previous filtering parameters for white level compensation (Not used.)	0: Enable 1: Disable
5 8	Not used.	

NOTE: Selector 4 is not applicable to models equipped with flat-bed scanners.

- **Selectors 1 and 2: Monitoring the PC ON/OFF state (Not used.)**

For the related functions, refer to WSW36, selectors 2 and 3.

- **Selector 3: Parallel port output pins kept at high level (Not used.)**

Setting this selector to "0" will keep all parallel output pins of the machine at high level. Use this setting if Resource Manager (bundled with MFC models) installed to WindowsNT running on the connected PC fails to monitor the power ON/OFF state of the machine.

- **Selector 4: Previous filtering parameters for white level compensation (Not used.)**

At the start of scanning operation, the machine usually initializes white and black level data stored in the EEPROM by scanning the while-level reference film attached to the inside of the scanner top cover. After long use of the machine, however, the film may be contaminated with dust or dirt. Accordingly, incorrect white level data will be set up so that white vertical streaks will be brought on the scanning result.

Setting this selector to "0" (Enabled) will apply previously saved white level data instead of new incorrect compensation.

WSW47 (Switching between high- and full-speed USB)

Selector No.	Function	Setting and Specifications
1	Handling paper at the occurrence of a paper feed timing error	0: Eject paper w/o print 1: Print on the current paper
2	Not used.	
3 4	Delay of FAX line disconnection when switching to the pseudo-ringing external telephone	No. 3 4 0 0 : 200 ms 0 1 : 400 ms 1 0 : 700 ms 1 1 : 1000 ms
5	Disable the ringer of external telephone at non-ring reception	0: No 1: Yes
6	Not used.	
7	Disable the ringer of external telephone with CAR signal when caller ID service is available	0: No 1: Yes
8	Switching between high-speed USB and full-speed USB	0: Auto switching between high-speed USB (ver. 2.0) and full-speed USB (ver. 1.1) 1: Fixed to full-speed USB (ver. 1.1)

NOTE: Selector 1 is applicable only to models equipped with flat-bed scanners.

NOTE: Selectors 3 and 4 are applicable only to models supporting pseudo-ringing of a connected external telephone.

- **Selector 1: Handling paper at the occurrence of a paper feed timing error**

When feeding paper to the print start position, the machine might cause a feed timing error so that the registration sensor goes ON signaling the presence of paper. This selector determines whether the machine prints on the current paper or ejects the current paper without printing and prints on the next paper.

- **Selectors 3 and 4: Delay of FAX line disconnection when switching to the pseudo-ringing external telephone**

When the machine receives a phone call, it can make the connected external telephone ring (so called pseudo-ringing). During pseudo-ringing, if you pick up the handset of the external telephone, the line might be disconnected due to cut-off of the line current. To hold the line, the machine may supply line current by making use of the pulse generator circuit that forms a parallel loop. This way the FAX line disconnection may be delayed. These selectors determine the delay period.

WSW48 (USB setup latency)

Selector No.	Function	Setting and Specifications
1 5	Not used.	
6 8	USB setup latency	No. 6 7 8 0 0 0 : Default period 0 0 1 : Shorter 1 0 1 0 : Longer 1 0 1 1 : Longer 2 1 0 0 : Longer 3 1 0 1 : Longer 4 1 0 0 : Shorter 2 1 1 1 : Shorter 3

- **Selectors 6 through 8: USB setup latency**

These selectors should not be disturbed.

WSW49 (End-of-copying beep and print in black)

Selector No.	Function	Setting and Specifications
1 2	Not used.	
3	End-of-copying beep	0: Yes 1: No
4 5	Command flag detection time	No. 4 5 0 0 : 150 ms 0 1 : 350 ms 1 0 : 550 ms 1 1 : 750 ms
6 8	Not used.	

- **Selectors 4 and 5: Command flag detection time**

After receiving a command flag, the machine will wait for the command that should follow for the time length specified by these selectors.

WSW50 (SDAA settings)

Selector No.	Function	Setting and Specifications
1 2	Percentage voltage for interpreting the external telephone as being hooked up (based on the network's standard voltage) (Not used)	No. 1 2 0 0 : 80% 0 1 : 90% 1 0 : 70% 1 1 : No detection
3	DC mask curve table to be applied when the line is connected (Not used)	0: Apply the initial value specified by local regulations 1: Apply table DC5 prepared specially
4	AC impedance to be applied when the line is connected (Not used)	0: 600Ω termination 1: ZR termination
5 6	Current control to be applied immediately after connection of the line (Not used)	No. 5 6 0 0 : Standard 0 1 : Increase start-up current for termination 1 0 : Fine current control for termination 1 1 : Not used. (equal to "0, 0")
7 8	AC voltage threshold for detection of ring (Not used)	No. 7 8 0 0 : 19 V 0 1 : 11 V 1 0 : 25 V 1 1 : 31 V

NOTE: WSW50 is applicable to models equipped with SDAA circuits.

WSW51 (Function setting 16)

Selector No.	Function	Setting and Specifications
1	Output of communications error report when transmission verification report is disabled	0: Enable 1: Disable
2 8	Not used.	

MFC7420/7820N DCP7010/7020/7025

APPENDIX 5. WIRING DIAGRAM

This appendix provides the wiring diagram that helps you understand the connections between PCBs.

Confidential

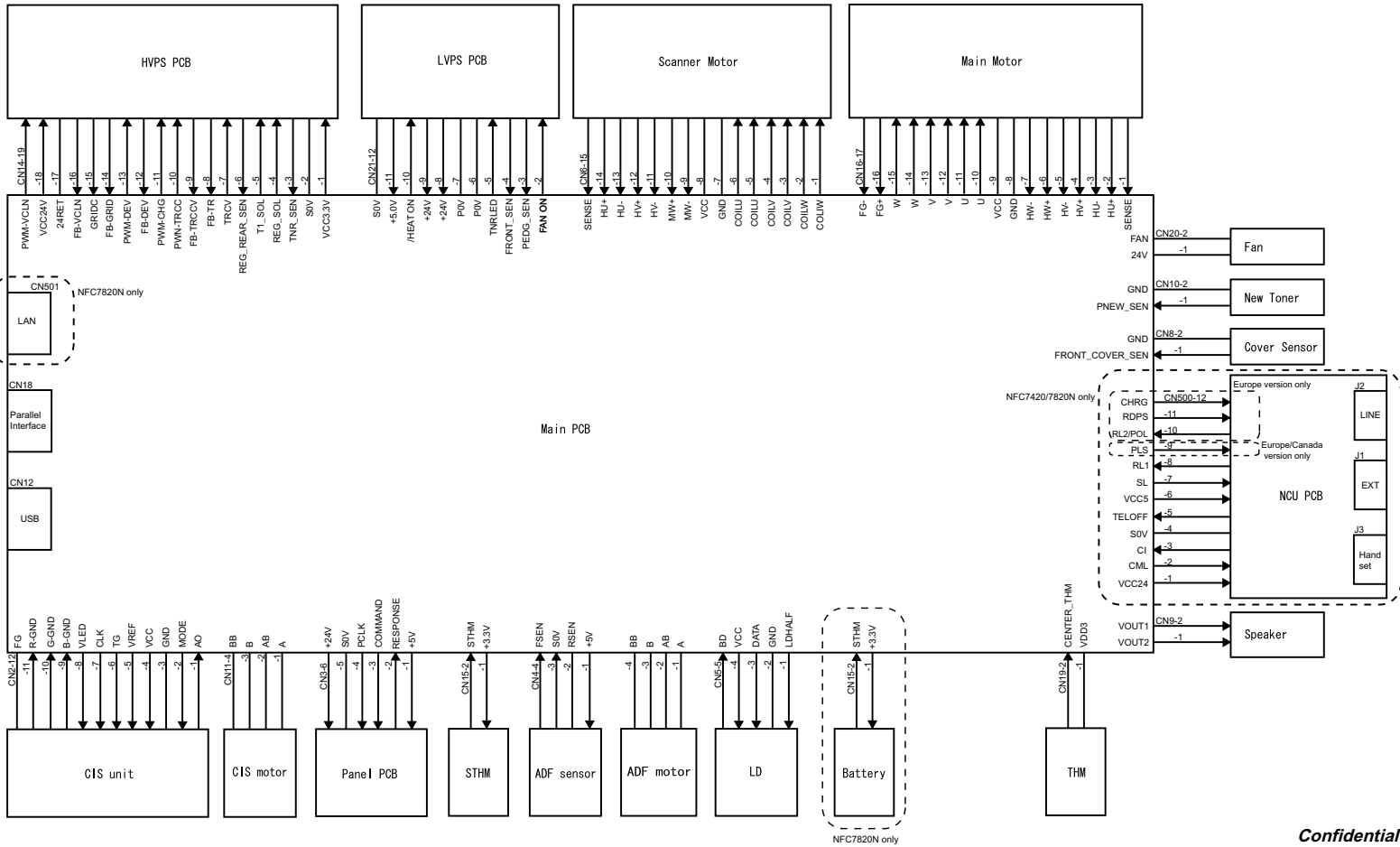

Confidential

MFC7420/7820N DCP7010/7020/7025

APPENDIX 6. CIRCUIT DIAGRAMS

This appendix provides the circuit diagrams of the NCU PCB and power supply PCB.

- A. NCU PCB: MFC7420 (U.S.A. and CANADA models)
NCU PCB: MFC7820N (U.S.A. and CANADA models)
NCU PCB: MFC7420 (EUROPE models)
NCU PCB: MFC7820N (EUROPE models)
- B. Power Supply PCB 100V (U.S.A. and CANADA models)
Power Supply PCB 200V (EUROPE models)

Confidential

A. NCU PCB: MFC7420 (U.S.A. and CANADA models)

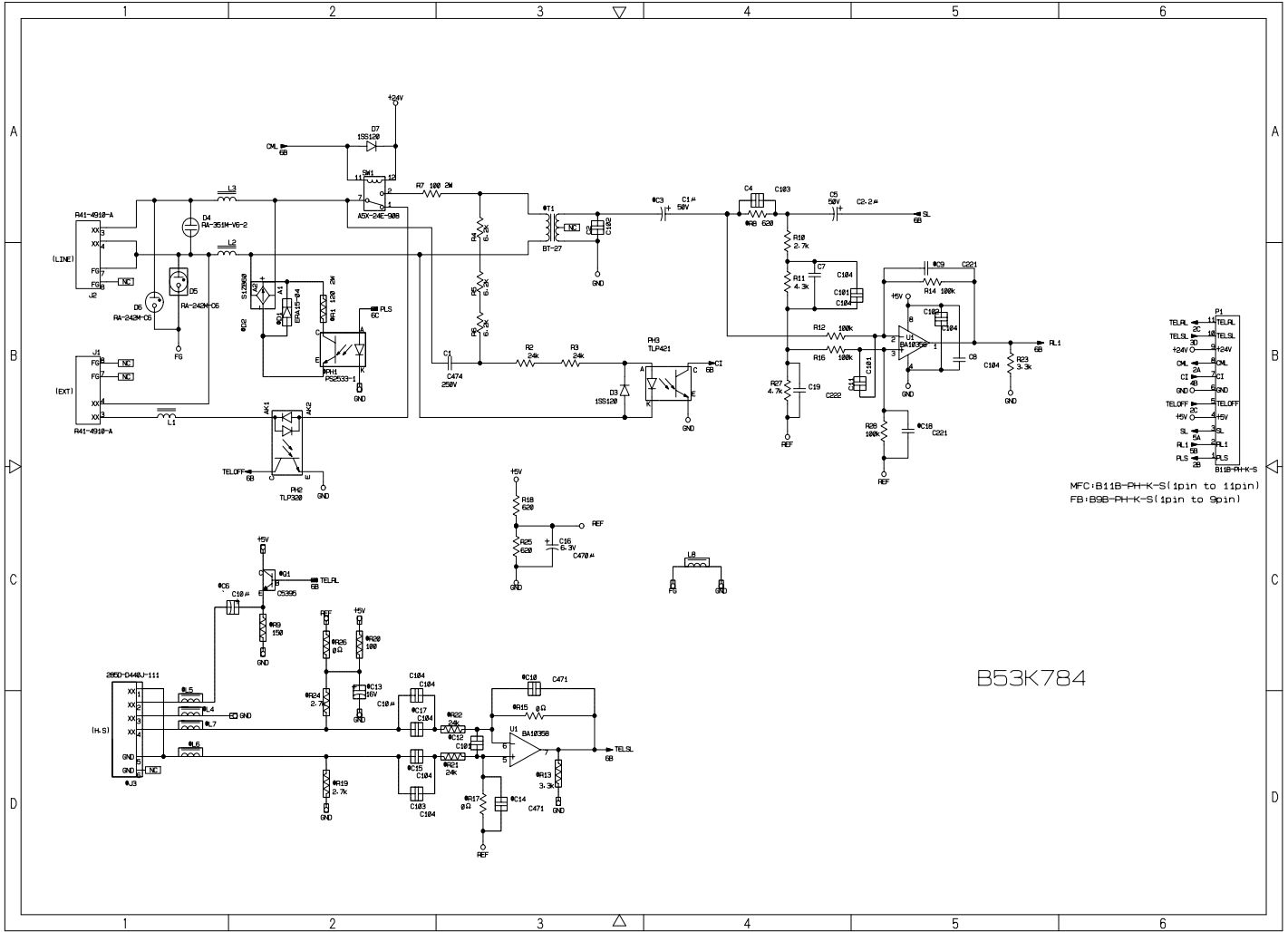

MFC-B11B-PH-K-S(1pin to 11pin)
FB:B5B-PH-K-S(1pin to 3pin)

B53K784

Confidential

A. NCU PCB: MFC7820N (U.S.A. and CANADA models)

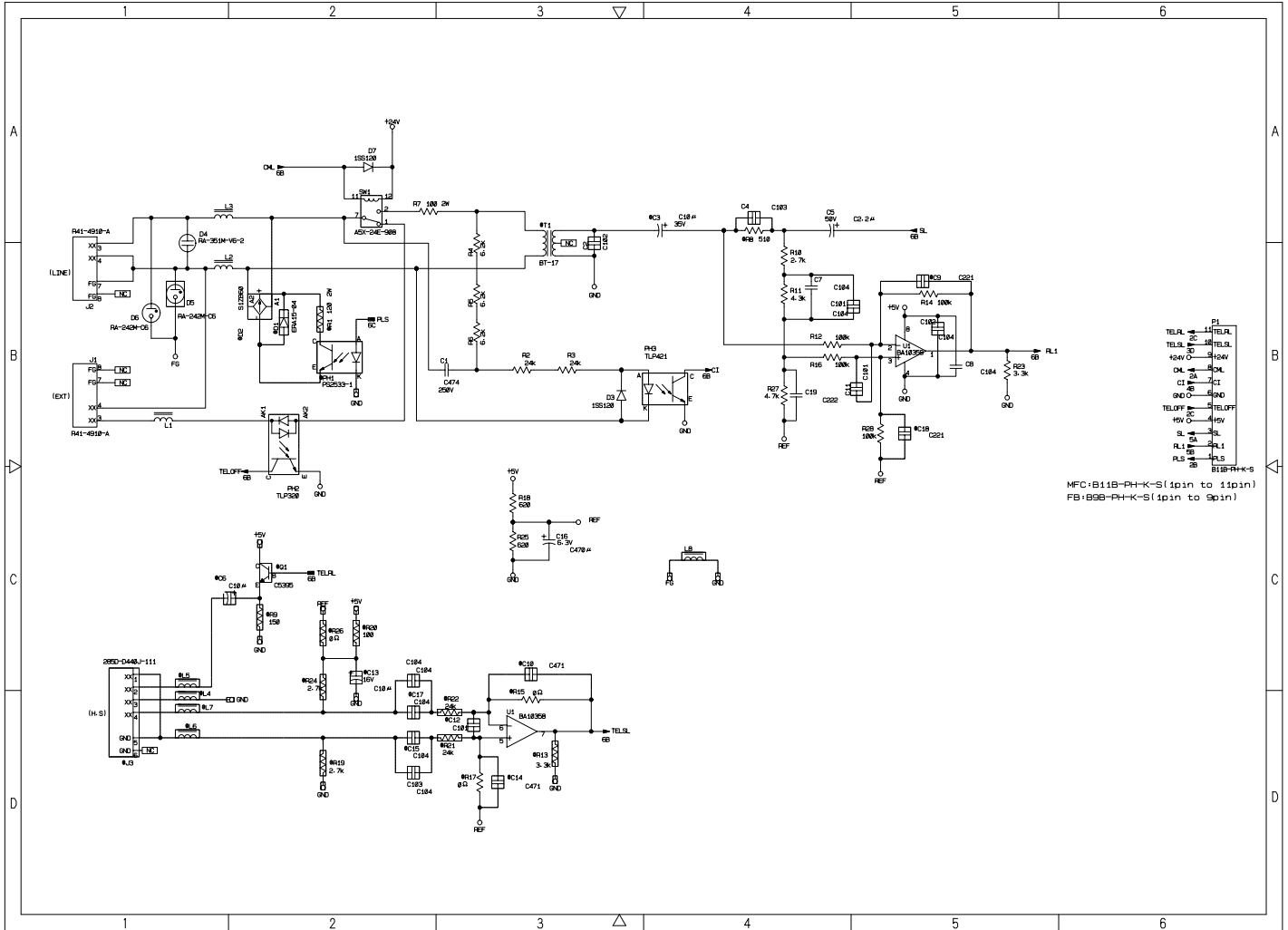

Confidential

A. NCU PCB: MFC7820N (EUROPE models)

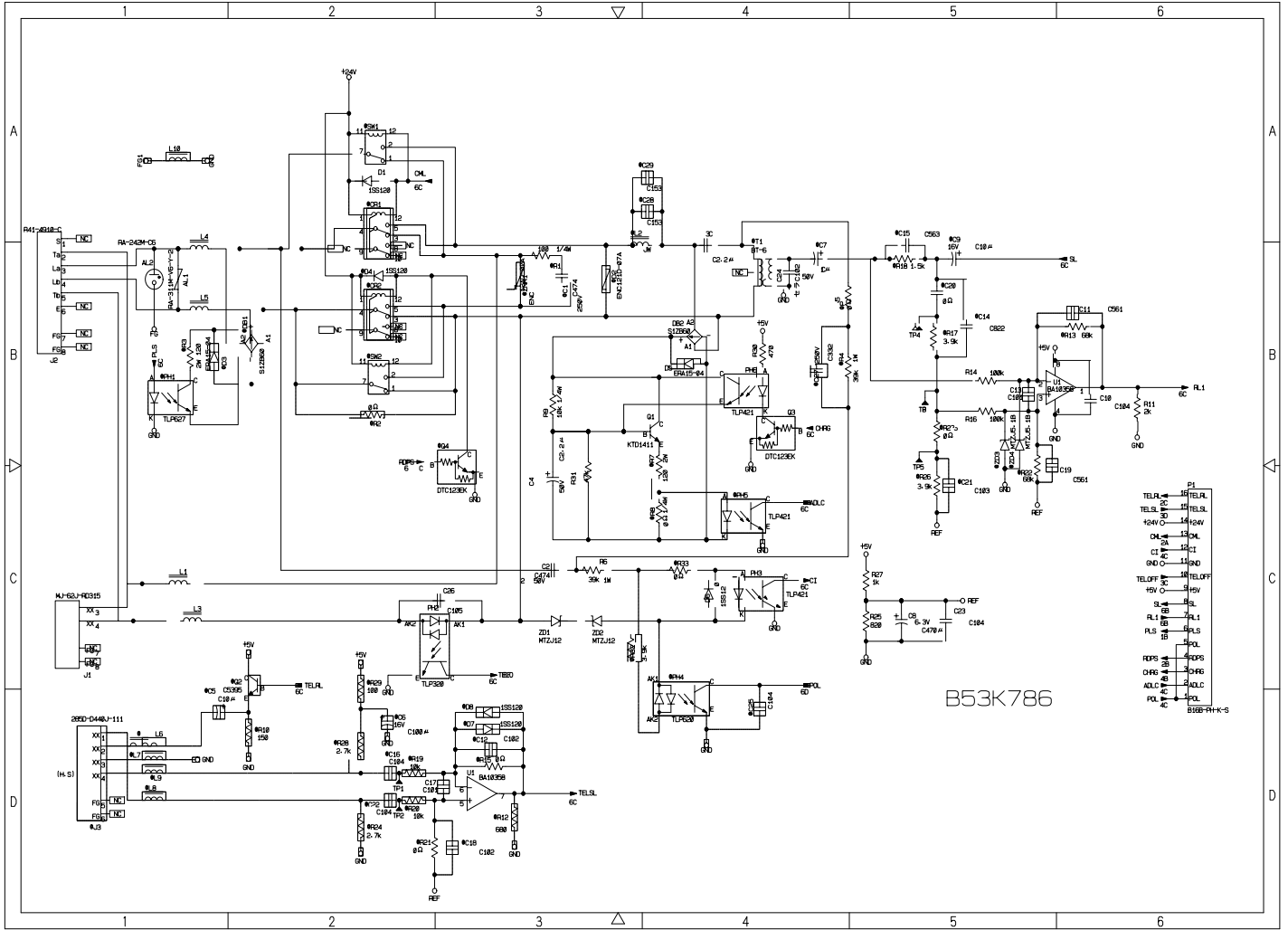

Confidential

B. Power Supply PCB 100V (U.S.A. and CANADA models)

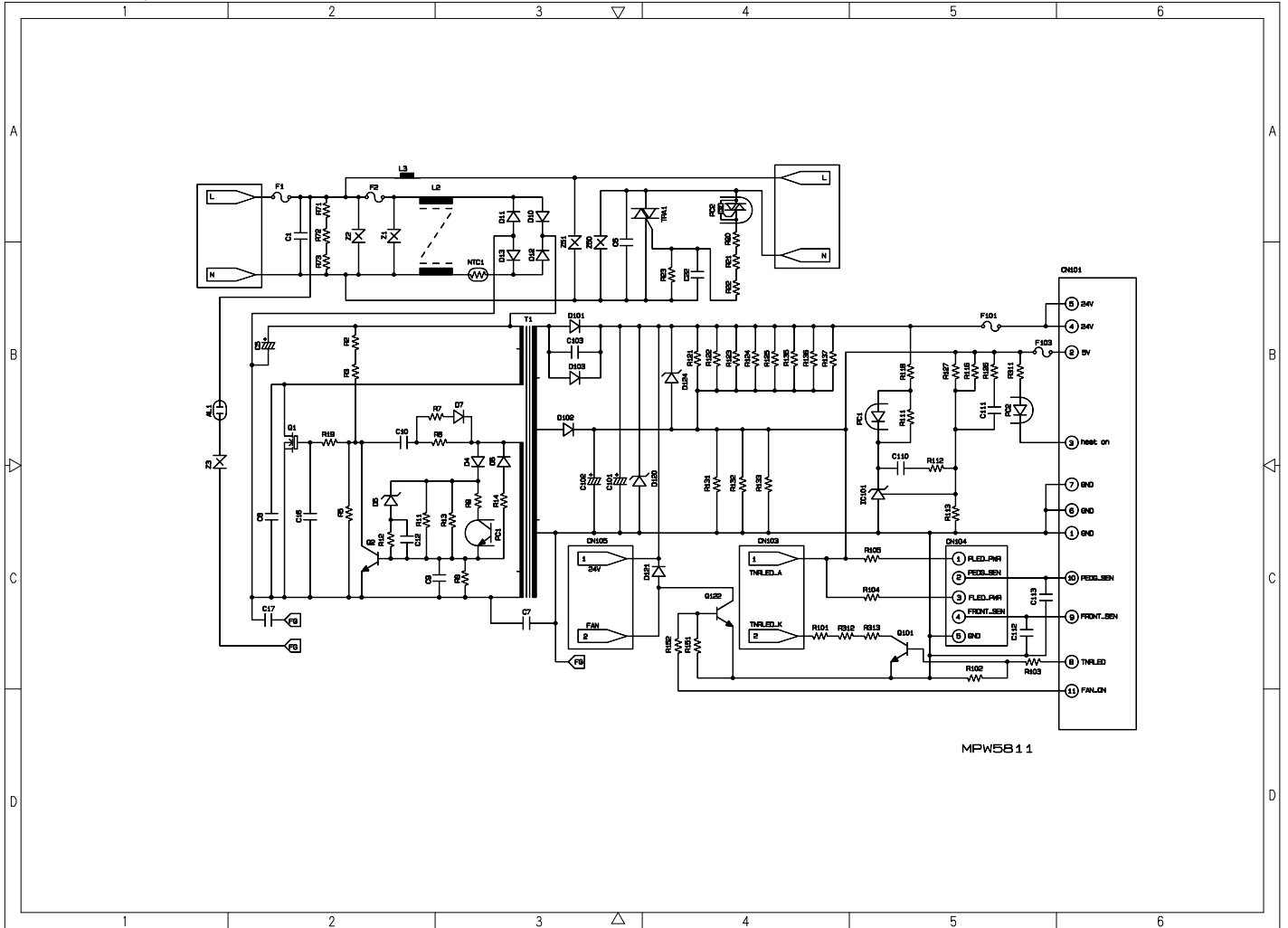

Confidential

B. Power Supply PCB 200V (EUROPE models)

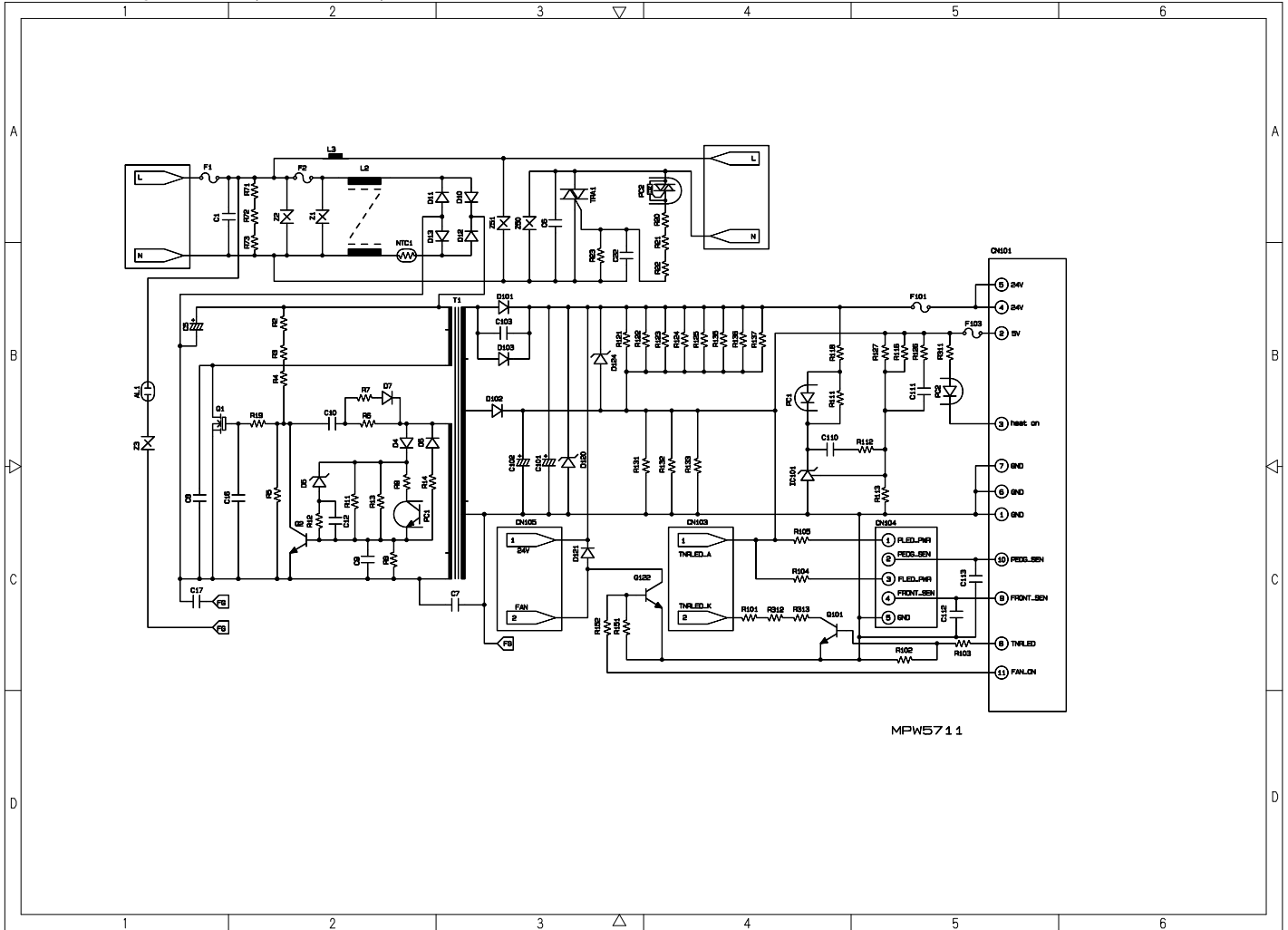

Confidential

brother®

December '04
SM-FAX036(2)
8C5A03
Printed in Japan