



# Brother Laser MFC

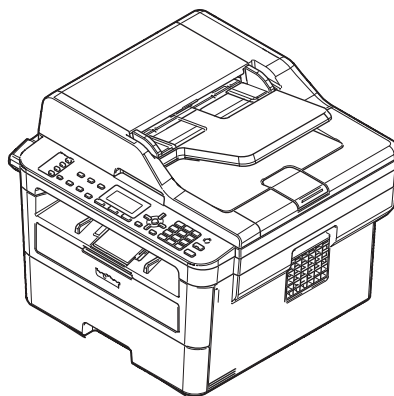
## SERVICE MANUAL

---

---

### MODEL

**DCP-7090/7095D/7190DN/7195DW**  
**DCP-B7500D/B7520DW/B7530DN/B7535DW**  
**DCP-L2510D/L2511D/L2512D/L2530DW**  
**DCP-L2531DW/L2532DW/L2535D/L2535DW**  
**DCP-L2536D/L2537DW/L2550DN/L2550DW**  
**DCP-L2551DN/L2551DW/L2552DN**  
**HL-L2390DW/L2395DW**  
**MFC-7390/7490D/7890DN/7895DW**  
**MFC-B7700D/B7715DW/B7720DN**  
**MFC-L2690DW/L2710DN/L2710DW/L2712DN**  
**MFC-L2712DW/L2713DW/L2715D/L2715DW**  
**MFC-L2716D/L2716DW/L2717DW**  
**MFC-L2730DW/L2732DW/L2750DW/L2750DWXL**  
**MFC-L2751DW/L2752DW/L2770DW/L2771DW**



Read this manual thoroughly before maintenance work.  
Keep this manual in a convenient place for quick and easy reference at all times.

August 2017  
SM-FAX186  
8C5K\*  
Ver.4

# Trademarks

BROTHER is either a trademark or a registered trademark of Brother Industries, Ltd.

Microsoft and Windows are registered trademarks of Microsoft Corporation in the United States and/or other countries.

Apple and Mac are trademarks of Apple Inc., registered in the U.S. and other countries.

AirPrint and the AirPrint logo are trademarks of Apple Inc.

App Store is a service mark of Apple Inc.

Wi-Fi is a registered trademark of Wi-Fi Alliance®.

Android is a trademark of Google Inc.

Google Play is a trademark of Google Inc.

Mopria® and the Mopria® Logo are registered trademarks and service marks of Mopria Alliance, Inc. in the United States and other countries. Unauthorized use is strictly prohibited.

Each company whose software title is mentioned in this manual has a Software License Agreement specific to its proprietary programs.

## Software Trademarks

FlashFX® is a registered trademark of Datalight, Inc.

FlashFX® Pro™ is a trademark of Datalight, Inc.

FlashFX® Tera™ is a trademark of Datalight, Inc.

Reliance™ is a trademark of Datalight, Inc.

Reliance Nitro™ is a trademark of Datalight, Inc.

Datalight® is a registered trademark of Datalight, Inc.

**Any trade names and product names of companies appearing on Brother products, related documents and any other materials are all trademarks or registered trademarks of those respective companies.**

# Open Source Licensing Remarks

This product includes open-source software.

Go to the manual download selection of your model's home page of Brother Solutions Center at [support.brother.com](http://support.brother.com) to view the Open Source Licensing Remarks and Copyright Information.

## Copyright and License

©2017 Brother Industries, Ltd. All rights reserved.

This product includes software developed by the following vendors:

©1983-1998 PACIFIC SOFTWARES, INC. ALL RIGHTS RESERVED.

©2008 Devicescape Software, Inc. All rights reserved.

This product includes the "KASAGO TCP/IP" software developed by ZUKEN ELMIC, Inc.

Copyright 1989-2014 Datalight, Inc., All Rights Reserved.

FlashFX<sup>®</sup> Copyright 1998-2014 Datalight, Inc.

U.S. Patent Office 5,860,082/6,260,156

# CONTENTS

## SAFETY INFORMATION

### CHAPTER 1 SUPPLEMENTAL SPECIFICATIONS

1. GENERAL .....	1-1
2. NETWORK CONNECTIVITY .....	1-9
3. SERVICE INFORMATION .....	1-10
4. SUPPLIES .....	1-12
5. MEDIA SPECIFICATIONS .....	1-20
6. FAX (ONLY FOR THE MODELS WITH FAX FUNCTION) .....	1-21
7. COPY .....	1-22
8. SCANNER .....	1-24

### CHAPTER 2 ERROR INDICATIONS AND TROUBLESHOOTING

1. INTRODUCTION .....	2-1
1.1 Precautions .....	2-1
1.2 Checks before Commencing Troubleshooting .....	2-3
2. OVERVIEW .....	2-5
2.1 Cross-section Drawing .....	2-5
2.1.1 Printer part .....	2-5
2.1.2 Scanner part .....	2-7
2.2 Paper Feeding .....	2-9
2.2.1 Printer part .....	2-9
2.2.2 Scanner part .....	2-11
2.3 Operation of Each Part and Location of Parts .....	2-12
2.4 Block Diagram .....	2-14
2.5 Main Components .....	2-15
3. ERROR INDICATIONS .....	2-17
3.1 Error Codes .....	2-17
3.2 Error Message .....	2-25
3.2.1 LCD models .....	2-25
3.2.2 Touch panel models .....	2-34
3.3 Communication Errors .....	2-43
4. TROUBLESHOOTING .....	2-47
4.1 Error Cause and Remedy .....	2-47
4.2 Troubleshooting for Paper Feeding Problems .....	2-73
4.2.1 No paper feeding from paper tray .....	2-73



4.2.2	No paper feeding from MP tray .....	2-74
4.2.3	No paper feeding from manual feed slot .....	2-75
4.2.4	Multiple sheets of paper are fed .....	2-75
4.2.5	Paper becomes wrinkled .....	2-76
4.2.6	Paper is fed at an angle .....	2-76
4.2.7	Paper curls .....	2-77
4.2.8	Unable to perform 2-sided printing .....	2-77
4.2.9	Paper jam .....	2-78
4.3	Troubleshooting for Image Defects .....	2-83
4.3.1	Image defect examples .....	2-83
4.3.2	Troubleshooting image defect .....	2-84
4.4	Troubleshooting for Software Problems .....	2-98
4.4.1	Unable to receive data .....	2-98
4.5	Troubleshooting for Network Problems .....	2-99
4.5.1	Cannot make a print through network connection .....	2-99
4.5.2	Cannot connect to access point .....	2-99
4.6	Troubleshooting for Control Panel Problems .....	2-100
4.6.1	Nothing is displayed on the LCD .....	2-100
4.6.2	Nothing is displayed on the LED .....	2-100
4.6.3	Unable to perform panel operation .....	2-100
4.7	Troubleshooting for Toner Cartridge and Drum Unit Problems .....	2-101
4.7.1	New toner not detected .....	2-101
4.7.2	Toner cartridge not detected .....	2-101
4.7.3	Toner replacement message displayed on LCD is not cleared .....	2-102
4.7.4	Drum error .....	2-102
4.7.5	Drum replacement message displayed on LCD is not cleared .....	2-102
4.8	Troubleshooting for Fuser Unit Problems .....	2-103
4.8.1	Fuser unit failure .....	2-103
4.9	Troubleshooting for Laser Unit Problems .....	2-103
4.9.1	Laser unit failure .....	2-103
4.10	Troubleshooting for PCB Problems .....	2-104
4.10.1	Main PCB failure .....	2-104
4.10.2	Full memory .....	2-104
4.11	Troubleshooting for Document Feeding Problems .....	2-105
4.11.1	No document is fed .....	2-105
4.11.2	Multiple documents are fed .....	2-105
4.11.3	Document jam .....	2-106
4.11.4	Document becomes wrinkled .....	2-107
4.11.5	Document size is not detected correctly .....	2-107
4.12	Troubleshooting for Scanning Image Defect .....	2-108
4.12.1	Defect examples .....	2-108
4.12.2	Troubleshooting according to image defect .....	2-108
4.13	Troubleshooting for FAX/Phone Problems .....	2-113
4.13.1	Fax cannot be sent .....	2-113
4.13.2	Fax cannot be received .....	2-114

4.13.3	Communication error occurs	2-114
4.13.4	Receive buffer full during receiving into memory	2-114
4.14	Troubleshooting for Other Problems	2-115
4.14.1	Cannot make print	2-115
4.14.2	Cannot update firmware	2-116
4.14.3	“Paper Low” message does not disappear	2-116
4.14.4	Message indicating that the report is full does not disappear	2-117
4.14.5	Paper tray cannot be recognized	2-117

## CHAPTER 3 DISASSEMBLY/REASSEMBLY

1.	SAFETY PRECAUTIONS	3-1
2.	PACKING	3-2
3.	SCREW CATALOGUE	3-3
4.	SCREW TORQUE LIST	3-4
5.	LUBRICATION	3-6
6.	OVERVIEW OF GEARS	3-7
7.	HARNESS ROUTING	3-9
8.	DISASSEMBLY FLOW CHART	3-22
9.	DISASSEMBLY PROCEDURE	3-23
9.1	Preparation	3-23
9.2	Cord hook	3-25
9.3	Back cover	3-26
9.4	Outer chute ASSY	3-27
9.5	Front cover ASSY / Support flap	3-28
9.6	Side cover R	3-31
9.7	Fuser cover	3-32
9.8	Inner chute ASSY	3-33
9.9	Side cover L / Speaker harness ASSY / Handset holder ASSY (For models with Handset)	3-34
9.10	Document scanner unit	3-37
9.11	ADF unit (For models with ADF)	3-40
9.11.1	ADF unit	3-40
9.11.2	ADF cover ASSY / Document stopper	3-43
9.11.3	Document sub tray	3-44
9.11.4	Document separate roller ASSY	3-46
9.11.5	ADF separation holder ASSY	3-47
9.11.6	Second side CIS unit / Second side CIS flat cable (Only for models with duplex scanning)	3-48
9.12	Document cover ASSY (For models without ADF)	3-53
9.13	Panel unit (For Touch panel models)	3-55
9.13.1	Panel unit	3-55

9.13.2	Panel PCB ASSY / NFC PCB ASSY / LCD .....	3-56
9.13.3	Touch panel ASSY .....	3-57
9.14	Panel unit (For Non-touch panel models) .....	3-58
9.14.1	Panel unit .....	3-58
9.14.2	Panel PCB ASSY .....	3-59
9.14.3	LCD .....	3-60
9.15	Panel flat cable / First side CIS unit / First side CIS flat cable .....	3-61
9.16	Modem flat cable / Modem PCB ASSY .....	3-68
9.17	Joint cover ASSY .....	3-70
9.18	Fuser unit .....	3-71
9.19	Low-voltage power supply PCB ASSY .....	3-73
9.20	New toner sensor PCB ASSY .....	3-75
9.21	HVPS flat cable / High-voltage power supply PCB ASSY .....	3-76
9.22	Fan .....	3-78
9.23	Toner box relay PCB ASSY (For models with toner box)/ MP relay PCB ASSY (For MP models) / Toner box new PCB ASSY (For models with toner box) .....	3-79
9.24	Laser unit flat cable / Laser unit .....	3-81
9.25	Filter .....	3-83
9.26	Wireless LAN PCB (Only for wireless network models) .....	3-84
9.27	Roller holder ASSY .....	3-85
9.28	Main PCB ASSY .....	3-86
9.29	T1 clutch / Registration clutch .....	3-87
9.30	Frame L unit .....	3-90
9.31	Paper feed motor / Paper feed motor flat cable .....	3-93
9.32	Fuser gear 64R/36R .....	3-95
9.33	Toner sensor PCB ASSY (Only for models with Toner box) .....	3-96
9.34	Front cover sensor .....	3-97
9.35	Eject sensor PCB ASSY .....	3-98
9.36	Registration front/rear actuator holder ASSY .....	3-100
9.37	Paper feed roller ASSY / Paper feed sensor PCB ASSY .....	3-103

## **CHAPTER 4 ADJUSTING AND UPDATING SETTINGS AS REQUIRED AFTER PARTS REPLACEMENT**

<b>1.</b>	<b>IF YOU REPLACE THE MAIN PCB ASSY .....</b>	<b>4-1</b>
1.1	Installing Firmware (Sub firmware and main firmware) .....	4-2
1.1.1	Checking firmware version .....	4-2
1.1.2	Installing firmware .....	4-3
1.2	Initializing the EEPROM of the Main PCB ASSY(Function code 01) .....	4-3
1.3	Setting by Spec, Setting Serial Number and Entering Adjusted Value of Laser Unit .....	4-4
1.4	Adjusting Touch Panel (Function code 61)(Touch panel models only) .....	4-6
1.5	Acquiring White Level Data (Function code 55) .....	4-6

<b>2. IF YOU REPLACE THE LOW-VOLTAGE POWER SUPPLY PCB ASSY .....</b>	<b>4-7</b>
2.1 Reset Irregular Power Supply Detection Counter of the Low-voltage Power Supply PCB (Function code 88) .....	4-7
<b>3. IF YOU REPLACE THE LASER UNIT .....</b>	<b>4-8</b>
3.1 Entering Adjusted Value of Laser Unit .....	4-9
<b>4. IF YOU REPLACE THE PANEL UNIT OR PANEL CONTROL PCB .....</b>	<b>4-11</b>
4.1 Adjusting Touch Panel (Function code 61) (Touch panel models only) .....	4-11
4.2 Checking LCD Operation (Function code 12) .....	4-11
<b>5. IF YOU REPLACE THE ADF UNIT, FIRST SIDE CIS UNIT,     SECOND SIDE CIS UNIT OR DOCUMENT SCANNER UNIT .....</b>	<b>4-12</b>
5.1 Acquiring White Level Data (Function code 55) .....	4-12
5.2 Scanning and Printing Check .....	4-12

## CHAPTER 5 SERVICE FUNCTIONS

<b>1. FUNCTION CODE .....</b>	<b>5-1</b>
1.1 How to Enter Maintenance Mode .....	5-1
1.1.1 Method of entering maintenance mode for service personnel .....	5-1
1.1.2 Method of entering end-user accessible maintenance mode .....	5-2
1.2 List of Maintenance Mode Functions .....	5-3
1.3 Details of Maintenance Mode Functions .....	5-4
1.3.1 Initialize EEPROM parameters (Function code 01, 91) .....	5-4
1.3.2 Transition to shipping state (Function code 03) .....	5-5
1.3.3 ADF performance test (Function code 08) .....	5-6
1.3.4 Print quality test pattern (Function code 09) .....	5-7
1.3.5 Set worker switches (WSW) and print worker switch setting data (Function code 10, 11) .....	5-8
1.3.6 Check LCD operation (Function code 12) .....	5-11
1.3.7 Check control panel key operation (Function code 13) .....	5-13
1.3.8 Display software version (Function code 25) .....	5-15
1.3.9 Check sensor operation (Function code 32) .....	5-16
1.3.10 Display LAN connection status (Function code 33) .....	5-18
1.3.11 Set PC print functions (Function code 43) .....	5-19
1.3.12 Change USB No. return value / Adjust left-end print position / Adjust upper-end print position / Change ON/OFF setting for lower case compensation / Change ON/OFF setting for fixation strength improvement (Function code 45) .....	5-23
1.3.13 Adjust printable range for each speed level (Function code 46) .....	5-27
1.3.14 Transfer received fax data / log information (fax models only) (Function code 53) .....	5-29
1.3.15 Fine-tune scanning position (Function code 54) .....	5-31
1.3.16 Acquire white level data and set CIS scan area (Function code 55) .....	5-32
1.3.17 Check toner cartridge (Models with cartridge sensor only) (Function code 57) ...	5-33
1.3.18 Adjust touch panel (Function code 61) .....	5-35
1.3.19 Continuous print test (Function code 67) .....	5-36

1.3.20	Print frame pattern (single-side printing) (Function code 69)	5-40
1.3.21	Print frame pattern (duplex printing) (Function code 70)	5-41
1.3.22	Test pattern (Function code 71)	5-42
1.3.23	Configure for country/region and model (Function code 74)	5-45
1.3.24	Print maintenance information (Function code 77)	5-52
1.3.25	Check fan operation (Function code 78)	5-54
1.3.26	Delete fax data (Function code 79)	5-54
1.3.27	Display machine log information (Function code 80)	5-55
1.3.28	Display machine error code (Function code 82)	5-57
1.3.29	Send communication log information to telephone line (Function code 87)	5-58
1.3.30	Reset irregular power supply detection counter of low-voltage power supply PCB (Function code 88)	5-58
1.3.31	Quit maintenance mode (Function code 99)	5-58
<b>2.</b>	<b>OTHER SERVICE FUNCTIONS</b>	<b>5-59</b>
2.1	Drum Cleaning	5-59
2.2	Print Communication Error List	5-61
2.3	Resetting Drum Counter	5-62
<b>CHAPTER 6 WIRING DIAGRAM</b>		
<b>1.</b>	<b>WIRING DIAGRAM</b>	<b>6-1</b>
<b>CHAPTER 7 PERIODICAL MAINTENANCE</b>		
<b>1.</b>	<b>PERIODICAL REPLACEMENT PARTS</b>	<b>7-1</b>
<b>APPENDIX 1 SERIAL NUMBERING SYSTEM</b>		
<b>APPENDIX 2 DELETING USER SETTING INFORMATION</b>		
<b>APPENDIX 3 INSTALLING THE MAINTENANCE PRINTER DRIVER</b>		

# SAFETY INFORMATION

## ■ Definitions of Warnings, Cautions, and Notes and Memos

The following conventions are used in this manual:

### **WARNING**

WARNING indicates a potentially hazardous situation which, if not avoided, could result in death or serious injuries.

### **CAUTION**

CAUTION indicates a potentially hazardous situation which, if not avoided, may result in minor or moderate injuries.

### **IMPORTANT**

IMPORTANT indicates a potentially hazardous situation which, if not avoided, may result in damage to property or loss of product functionality.



Prohibition icons indicate actions that must not be performed.



Electrical Hazard icons alert you to possible electrical Shock.



Fire hazard icons alert you to the possibility of a fire.



Hot Surface icons warn you not to touch product parts that are hot.

**Note** NOTE specifies the operating environment, conditions for installation, or special conditions of use.

■ **To use the Machine Safely**

Please keep these instructions for later reference and read them before attempting any maintenance. If you do not follow these safety instructions, there is a possibility of a fire, electrical shock, burn or suffocation.

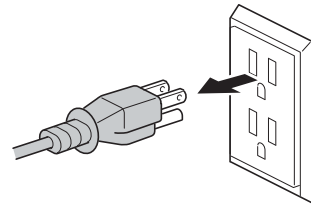
 **WARNING**

  **ELECTRICAL HAZARDS**

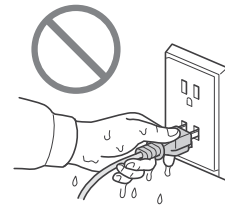
Failure to follow the warnings in this section may create the risk of an electrical shock. In addition, you could create an electrical short, which may create the risk of a fire.



There are high-voltage electrodes inside the product. Before you access the inside of the product, including for routine maintenance such as cleaning, make sure you have unplugged the telephone line cord first (MFC models only) and then the power cord from the AC power outlet, as well as any telephone/RJ-11 (MFC models only) or Ethernet/RJ-45 cables (Network models only) from the product. **DO NOT** push objects of any kind into this product through slots or openings in the product, as they may touch dangerous voltage points or short out parts.



**DO NOT** handle the plug with wet hands. Doing this might cause an electrical shock.



**DO NOT** use this product during a thunderstorm. There may be a remote risk of an electrical shock from lightning.



Always make sure the plug is fully inserted. **DO NOT** use the product or handle the cord if the cord has become worn or frayed.



**DO NOT** allow this product to come into contact with water. This product should not be used around standing water, including a bath tub, sink, or swimming pool; around appliances containing water, including a refrigerator; or in a wet basement.



This product should be connected to an AC power source within the range indicated on the rating label (You can find the rating label on your machine). **DO NOT** connect it to a DC power source or inverter. If you are not sure what kind of power source you have, contact a qualified electrician.

 **WARNING**

When removing the Low-voltage power supply, do not touch it within **3 minutes** after disconnecting the AC cord as it may cause an electric shock due to the electric charge accumulated in the capacitor.

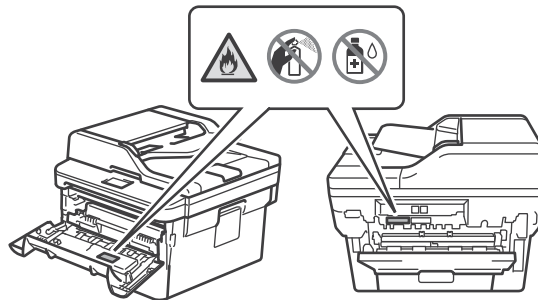


**Power Cord Safety:**

- This product is equipped with a grounded plug. This plug will only fit into a grounded power outlet. This is a safety feature. If you are unable to insert the plug into the outlet, call your electrician to replace your obsolete outlet. **DO NOT** attempt to defeat the purpose of the grounded plug.
- **DO NOT** allow anything to rest on the power cord.
- **DO NOT** place this product where people might step on the cord.
- **DO NOT** place this product in a position where the cord is stretched or strained, as it may become worn or frayed.
- **DO NOT** use the product if the power cord is frayed or damaged. Doing so may cause an electrical shock or fire.
- **DO NOT** pull on the middle of the AC power cord; pulling on the middle may cause the cord to separate from the plug. Doing this might cause an electrical shock.
- Brother strongly recommends that you **DO NOT** use any type of extension cord.



- **DO NOT** put toner cartridges or a toner cartridge and drum unit assembly into a fire or places susceptible to fire. It could explode, resulting in injuries.
- **DO NOT** use flammable substances, any type of spray, or an organic solvent/liquid containing alcohol or ammonia to clean the inside or outside of the product. Doing so could cause a fire or electrical shock. Instead, use only a dry, lint-free cloth.



**DO NOT** attempt to operate this product when a paper jam or stray pieces of paper are inside the product. Prolonged contact of paper with the fuser unit could cause a fire.

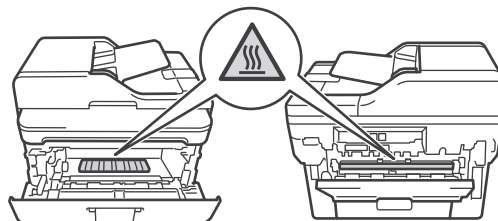


**DO NOT** use a vacuum cleaner to clean up scattered toner. Doing this might cause the toner dust to ignite inside the vacuum cleaner, potentially starting a fire. Carefully clean the toner dust with a dry, lint-free soft cloth and dispose of it according to local regulations.



**HOT SURFACE**

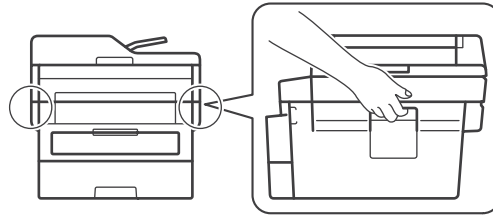
Immediately after using the product, some internal parts of the product will be extremely hot. Wait at least 10 minutes for the product to cool down before you touch the internal parts of the product.





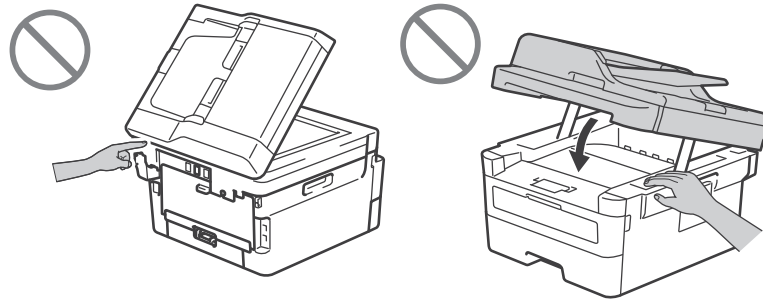


When you move the product, carry the product as shown in the illustration.



(Products with scanning function only)

To prevent injuries, be careful not to put your fingers in the areas shown in the illustrations.



(MFC models only)

When using your telephone equipment, basic safety precautions should always be followed to reduce the risk of fire, electrical shock, and injury to people. These important safety precautions include the following:

1. DO NOT use this product near water or locations that may become wet, for example, near a bathtub, wash bowl, kitchen sink or washing machine, in a wet basement or near a swimming pool.
2. Avoid using this product during a thunderstorm. There may be a remote risk of an electric shock from lightning.
3. DO NOT use this product to report a gas leak in the vicinity of the leak.
4. Use only the power cord provided with the product (if included in the box).

Read all of the instructions. Save them for later reference.



(MFC models only)

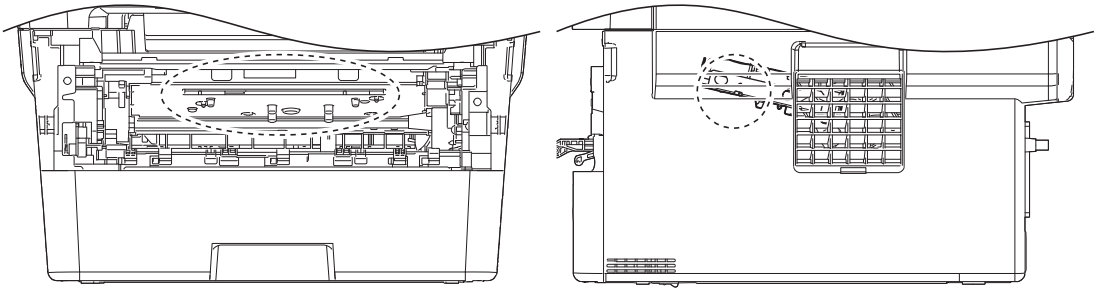
To reduce the risk of shock or fire, electrical shock, and injury to people; use only a No. 26 AWG or larger telecommunication line cord.

■ **Caution for Laser Product (WARNHINWEIS für Laserdrucker)**

CAUTION: In case of any trouble with the laser unit, replace the laser unit itself. To prevent direct exposure to the laser beam, do not try to open the enclosure of the laser unit.

ACHTUNG: Im Falle von Störungen der Lasereinheit muß diese ersetzt werden. Das Gehäuse der Lasereinheit darf nicht geöffnet werden, da sonst Laserstrahlen austreten können.

<Location of the scanner window>



■ **Additional Information**

When servicing the optical system of the machine, be careful not to place a screwdriver or other reflective object in the path of the laser beam. Be sure to take off any personal accessories such as watches and rings before working on the machine. A reflected beam, though invisible, can permanently damage the eyes.

Since the beam is invisible, the following caution in print is attached on the laser unit.



## ■ Standard Telephone and FCC Notices (MFC models only)

**These notices are in effect on models sold and used in the United States only.**

**When programming emergency numbers or making test calls to emergency numbers:**

- Remain on the line and briefly explain to the dispatcher the reason for the call before hanging up.
- Perform these activities in the off-peak hours, such as early morning or late evening.

This equipment complies with Part 68 of the FCC rules and the requirements adopted by the ACTA. On the backside of this equipment is a label that contains, among other information, a product identifier in the format US:AAAEQ##TXXXX. If requested, this number must be provided to the telephone company.

You may safely connect this equipment to the telephone line by means of a standard modular jack, USOC RJ11C.

A plug and jack used to connect this equipment to the premises wiring and telephone network must comply with the applicable FCC Part 68 rules and requirements adopted by the ACTA. A compliant telephone cord and modular plug is provided with this product. It is designed to be connected to a compatible modular jack that is also compliant. (See installation instructions for details.)

The Ringer Equivalence Number (REN) is used to determine the number of devices that may be connected to a telephone line. Excessive RENs on a telephone line may result in the devices not ringing in response to an incoming call. In most but not all areas, the sum of RENs should not exceed five (5.0). To be certain of the number of devices that may be connected to a line, as determined by the total RENs, contact the local telephone company. For products approved after July 23, 2001, the REN for this product is part of the product identifier that has the format US:AAAEQ##TXXXX. The digits represented by ## are the REN without a decimal point (e.g., 06 is a REN of 0.6). For earlier products, the REN is separately shown on the label.

If this equipment causes harm to the telephone network, the telephone company will notify you in advance that temporary discontinuance of service may be required. But if advance notice is not practical, the telephone company will notify the customer as soon as possible. Also, you will be advised of your right to file a complaint with the FCC if you believe it is necessary. The telephone company may make changes in its facilities, equipment, operations or procedures that could affect the operation of the equipment. If this happens the telephone company will provide advance notice in order for you to make necessary modifications to maintain uninterrupted service.

If trouble is experienced with this equipment, for repair or warranty information, please contact Brother Customer Service (see the Online User's Guide: Brother numbers). If the equipment is causing harm to the telephone network, the telephone company may request that you disconnect the equipment until the problem is resolved.

Connection to party line service is subject to state tariffs. Contact the state public utility commission, public service commission or corporation commission for information.

If your home has specially wired alarm equipment connected to the telephone line, ensure the installation of this equipment does not disable your alarm equipment. If you have questions about what will disable alarm equipment, call your telephone company or a qualified installer.

If you are not able to solve a problem with your product, contact Brother Customer Service (see the Online User's Guide: Brother numbers).



## **WARNING**

For protection against the risk of electrical shock, always disconnect all cables from the walloutlet before the equipment is installed, serviced, or modified.



DO NOT attempt to service this product yourself. Refer all servicing to a Brother Authorized Service Center.

## **IMPORTANT**

- This equipment may not be used on coin service lines provided by the telephone company or connected to party lines.
- Brother cannot accept any financial or other responsibilities that may be the result of your use of this information, including direct, special or consequential damages. There are no warranties extended or granted by this document.
- A grounded plug should be plugged into a grounded AC power outlet after checking the rating of the local power supply for the product to operate properly and safely.

# CHAPTER 1 SUPPLEMENTAL SPECIFICATIONS

## 1. GENERAL

The function comparative table for models as described in this Service Manual are shown below.

Model	DCP-7090	DCP-7095D	DCP-B7500D	DCP-B7520DW	DCP-L2510D DCP-L2511D DCP-L2512D	DCP-L2530DW DCP-L2531DW DCP-L2532DW
Wired/ Wireless LAN	N/A	N/A	N/A	Wired/Wireless	N/A	Wireless
Auto Duplex Print	N/A	✓	✓	✓	✓	✓
Duplex Scan	N/A	N/A	N/A	N/A	N/A	N/A
ADF	N/A	N/A	N/A	N/A	N/A	N/A
Auto Duplex Copy	N/A	N/A	N/A	N/A	N/A	N/A
Scanning Method	CIS	CIS	CIS	CIS	CIS	CIS
LCD Type	10 characters x 2 lines	10 characters x 2 lines	16 characters x 2 lines (for ASA) 10 characters x 2 lines (for CHN)	16 characters x 2 lines (except for CHN) 10 characters x 2 lines (for CHN)	16 characters x 2 lines	16 characters x 2 lines
FB	Up to A4/LTR	Up to A4/LTR	Up to A4/LTR	Up to A4/LTR	Up to A4/LTR	Up to A4/LTR
FAX	N/A	N/A	N/A	N/A	N/A	N/A
NFC	N/A	N/A	N/A	N/A	N/A	N/A
USB Host (front)	N/A	N/A	N/A	N/A	N/A	N/A
USB Host (rear)	N/A	N/A	N/A	N/A	N/A	N/A
Emulation	N/A	N/A	PCL6, BR- Script3, PDF Version 1.7	PCL6, BR- Script3, PDF Version 1.7	N/A	N/A
Paper Input/ Standard Tray	250 sheets	250 sheets	250 sheets	250 sheets	250 sheets	250 sheets
Paper Input/ MP Tray	N/A	N/A	N/A	N/A	N/A	N/A
Paper Input/ ADF	N/A	N/A	N/A	N/A	N/A	N/A
Paper Input/ Manual Feed Slot	1 sheet	1 sheet	1 sheet	1 sheet	1 sheet	1 sheet

Specifications are subject to change without notice.

Model	DCP-L2535D DCP-L2536D	DCP-L2535DW	DCP-L2537DW HL-L2390DW	DCP-7195DW	DCP-7190DN DCP-B7530DN DCP-L2550DN DCP-L2551DN DCP-L2552DN	DCP-B7535DW DCP-L2550DW DCP-L2551DW	HL-L2395DW
Wired/ Wireless LAN	N/A	Wireless	Wireless	Wired/ Wireless	Wired	Wired/ Wireless	Wired/ Wireless
Auto Duplex Print	✓	✓	✓	✓	✓	✓	✓
Duplex Scan	N/A	N/A	N/A	N/A	N/A	N/A	N/A
ADF	N/A	N/A	N/A	✓	✓	✓	N/A
Auto Duplex Copy	N/A	N/A	N/A	N/A	N/A	N/A	N/A
Scanning Method	CIS	CIS	CIS	CIS	CIS	CIS	CIS
LCD Type	16 characters x 2 lines	16 characters x 2 lines	16 characters x 2 lines	2.7" TFT ColorLCD (6.8 cm / 67.5 mm)	10 characters x 2 lines (DCP- 7190DN, B7530DN)  16 characters x 2 lines (except for DCP- B7530DN)	10 characters x 2 lines (DCP- B7535DW for CHN)  16 characters x 2 lines (except for DCP- B7535DW for CHN)	2.7" TFT ColorLCD (6.8 cm / 67.5 mm)
FB	Up to A4/ LTR	Up to A4/ LTR	Up to A4/ LTR	Up to A4/ LTR	Up to A4/ LTR	Up to A4/ LTR	Up to A4/ LTR
FAX	N/A	N/A	N/A	N/A	N/A	N/A	N/A
NFC	N/A	N/A	N/A	Yes (Link to Solutions Center / Print&Scan / Easy WLAN setting)	N/A	N/A	Yes (Link to Solutions Center / Print&Scan / Easy WLAN setting)
USB Host (front)	N/A	N/A	N/A	N/A	N/A	N/A	N/A
USB Host (rear)	N/A	N/A	N/A	N/A	N/A	N/A	N/A
Emulation	PCL6, BR- Script3, PDF Version 1.7	PCL6, BR- Script3, PDF Version 1.7	N/A	PCL6, BR- Script3, PDF Version 1.7	PCL6, BR- Script3, PDF Version 1.7	PCL6, BR- Script3, PDF Version 1.7	PCL6, BR- Script3,PDF Version 1.7
Paper Input/ Standard Tray	250 sheets	250 sheets	250 sheets	250 sheets	250 sheets	250 sheets	250 sheets
Paper Input/ MP Tray	N/A	N/A	N/A	30 sheets	N/A	N/A	N/A
Paper Input/ ADF	N/A	N/A	N/A	50 sheets	50 sheets	50 sheets	N/A
Paper Input/ Manual Feed Slot	1 sheet	1 sheet	1 sheet	N/A	1 sheet	1 sheet	1 sheet

Specifications are subject to change without notice.

Model	MFC-7390 MFC-7490D MFC-B7700D	MFC-B7715DW	MFC-B7720DN	MFC-L2690DW	MFC-L2710DN MFC-L2712DN	MFC-L2710DW MFC-L2712DW MFC-L2713DW	MFC-L2715D MFC-L2716D
Wired/ Wireless LAN	N/A	Wired/ Wireless	Wired	Wireless	Wired	Wired/ Wireless	N/A
Auto Duplex Print	✓ (except for MFC-7390) N/A (for MFC-7390)	✓	✓	✓	✓	✓	✓
Duplex Scan	N/A	N/A	N/A	N/A	N/A	N/A	N/A
ADF	✓	✓	✓	✓	✓	✓	✓
Auto Duplex Copy	N/A	N/A	N/A	N/A	N/A	N/A	N/A
Scanning Method	CIS	CIS	CIS	CIS	CIS	CIS	CIS
LCD Type	10 characters x 2 lines	16 characters x 2 lines	10 characters x 2 lines	16 characters x 2 lines	16 characters x 2 lines	16 characters x 2 lines	16 characters x 2 lines (except for KOR) 10 characters x 2 lines (for KOR)
FB	Up to A4/ LTR	Up to A4/ LTR	Up to A4/ LTR	Up to A4/ LTR	Up to A4/ LTR	Up to A4/ LTR	Up to A4/ LTR
FAX	✓	✓	✓	✓	✓	✓	✓
NFC	N/A	N/A	N/A	N/A	N/A	N/A	N/A
USB Host (front)	N/A	N/A	N/A	N/A	N/A	N/A	N/A
USB Host (rear)	N/A	N/A	N/A	N/A	N/A	N/A	N/A
Emulation	N/A	PCL6, BR- Script3, PDF Version 1.7	PCL6, BR- Script3, PDF Version 1.7	N/A	N/A	N/A	PCL6, BR- Script3, PDF Version 1.7
Paper Input/ Standard Tray	250 sheets	250 sheets	250 sheets	250 sheets	250 sheets	250 sheets	250 sheets
Paper Input/ MP Tray	N/A	N/A	N/A	N/A	N/A	N/A	N/A
Paper Input/ ADF	50 sheets	50 sheets	50 sheets	50 sheets	50 sheets	50 sheets	50 sheets
Paper Input/ Manual Feed Slot	1 sheet	1 sheet	1 sheet	1 sheet	1 sheet	1 sheet	1 sheet

Specifications are subject to change without notice.

Model	MFC-L2715DW MFC-L2716DW	MFC-L2717DW	MFC-7890DN	MFC-L2730DW MFC-L2732DW	MFC-7895DW MFC-L2770DW MFC-L2771DW	MFC-L2750DW MFC-L2750DWXL MFC-L2751DW MFC-L2752DW
Wired/ Wireless LAN	Wired/Wireless	Wired/Wireless	Wired	Wired/Wireless	Wired/Wireless	Wired/Wireless
Auto Duplex Print	✓	✓	✓	✓	✓	✓
Duplex Scan	N/A	N/A	N/A	N/A	✓	✓
ADF	✓	✓	✓	✓	✓	✓
Auto Duplex Copy	N/A	N/A	N/A	N/A	✓	✓
Scanning Method	CIS	CIS	CIS	CIS	Dual CIS	Dual CIS
LCD Type	16 characters x 2 lines (except for KOR/TWN)  10 characters x 2 lines (for KOR/TWN)	16 characters x 2 lines	10 characters x 2 lines	2.7" TFT ColorLCD (6.8 cm / 67.5 mm)	2.7" TFT ColorLCD (6.8 cm / 67.5 mm)	2.7" TFT ColorLCD (6.8 cm / 67.5 mm)
FB	Up to A4/LTR	Up to A4/LTR	Up to A4/LTR	Up to A4/LTR	Up to A4/LTR	Up to A4/LTR
FAX	✓	✓	✓	✓	✓	✓
NFC	N/A	N/A	N/A	N/A	Yes (Link to Solutions Center / Print&Scan / Easy WLAN setting)	Yes (Link to Solutions Center / Print&Scan / Easy WLAN setting)
USB Host (front)	N/A	N/A	N/A	N/A	N/A	N/A
USB Host (rear)	N/A	N/A	N/A	N/A	N/A	N/A
Emulation	PCL6, BR- Script3, PDF Version 1.7	N/A	PCL6, BR- Script3, PDF Version 1.7	PCL6, BR- Script3, PDF Version 1.7	PCL6, BR- Script3, PDF Version 1.7	PCL6, BR- Script3, PDF Version 1.7
Paper Input/ Standard Tray	250 sheets	250 sheets	250 sheets	250 sheets	250 sheets	250 sheets
Paper Input/ MP Tray	N/A	N/A	N/A	N/A	30 sheets  Envelope: 2 envelopes up to 0.23 mm thick	N/A
Paper Input/ ADF	50 sheets	50 sheets	50 sheets	50 sheets	50 sheets	50 sheets
Paper Input/ Manual Feed Slot	1 sheet	1 sheet	1 sheet	1 sheet	N/A	1 sheet

Specifications are subject to change without notice.



Model	DCP-7090 DCP-7095D	DCP-B7500D DCP-L2535D DCP-L2536D DCP-B7520DW DCP-B7530DN DCP-B7535DW	DCP-L2510D DCP-L2511D DCP-L2512D	DCP-L2530DW DCP-L2531DW DCP-L2532DW
Warm up Time (From Sleep Mode)	Less than 9 sec. at 73.4F / 50% (23°C / 50%)			
Warm up Time (From Power ON)	Less than 27 sec. at 73.4F / 50% (23°C / 50%)	Less than 27 sec. at 73.4F / 50% (23°C / 50%) (DCP-B7500D for ASA, B7500D for CHN, L2535D for ASA, L2536D for ASA) Less than 28 sec. at 73.4F / 50% (23°C / 50%) (DCP-B7520DW, B7530DN for CHN, B7535DW)	Less than 27 sec. at 73.4F / 50% (23°C / 50%)	Less than 28 sec. at 73.4F / 50% (23°C / 50%)
FPOT (From Ready Mode and Standard Tray)	Less than 8.5 sec. at 73.4F (23°C) / 230V			
FPOT (From Sleep Mode and Standard Tray)	Less than 17.5 sec. at 73.4F (23°C) / 230V			
Mono Print Speed (A4/Letter)	Up to 30/32 ppm (Quiet Mode: Up to 13/13 ppm)	Up to 34/36 ppm (Quiet Mode: Up to 13/13 ppm)	Up to 30/32 ppm (Quiet Mode: Up to 13/13 ppm)	
Full Color Print Speed (A4/Letter)	N/A			
Mono Duplex Print Speed (A4/Letter)	N/A	16/17 sides per minute (8/8.5 sheets per minute)	15/15 sides per minute (7.5/7.5 sheets per minute)	
Full Color Duplex Print Speed (A4/Letter)	N/A			
Processor	600 MHz			
Back up Clock	N/A			
Carton Dimensions (W x D x H)	580 x 517 x 434 mm 22.8" x 20.4" x 17.1"			
Machine Dimensions (W x D x H)	410 x 398.5 x 272 mm 16.1" x 15.7" x 10.7"	410 x 398.5 x 272 mm 16.1" x 15.7" x 10.7" (DCP-B7500D, L2535D, L2536D, B7520DW) 410 x 398.5 x 318.5 mm 16.1" x 15.7" x 12.5" (DCP-B7530DN, B7535DW)	410 x 398.5 x 272 mm 16.1" x 15.7" x 10.7"	
Weight w/ Carton	TBD	13.5 kg / 29.7 lb (DCP-B7500D, L2535D, B7520DW for CHN/LTN) 13.6 kg / 30.0 lb (DCP-B7520DW for EU) 14.8 kg / 32.6 lb (DCP-B7530DN, B7535DW)	13.1 kg / 28.9 lb (DCP-L2510D) 13.4 kg / 29.5 lb (DCP-L2512D) TBD (DCP-L2511D)	13.1 kg / 28.9 lb (DCP-L2530DW for EU) 13.2 kg / 29.2 lb (DCP-L2531DW) 13.4 kg / 29.6 lb (DCP-L2532DW) TBD (DCP-L2530DW for LTN)
Weight w/o Carton, w/ toner/drum	TBD	10.5 kg / 23.1 lb (DCP-B7500D, L2535D, B7520DW) 11.8 kg / 26.0 lb (DCP-B7530DN, B7535DW) TBD (DCP-L2536D)	10.3 kg / 22.7 lb (DCP-L2510D, L2512D) TBD (DCP-L2511D)	10.3 kg / 22.7 lb (except for DCP-L2530DW for LTN) TBD (DCP-L2530DW for LTN)
Weight w/o Carton and toner/drum	TBD	9.2 kg / 20.3 lb (DCP-L2535D) 9.4 kg / 20.7 lb (DCP-B7520DW for CHN/EU) 9.6 kg / 21.2 lb (DCP-B7500D, B7520DW for LTN) 10.9 kg / 24.0 lb (DCP-B7530DN, B7535DW) TBD (DCP-L2536D)	9.2 kg / 20.3 lb (DCP-L2510D, L2512D) TBD (DCP-L2511D)	9.2 kg / 20.3 lb (DCP-L2530DW for EU, L2532DW) 9.4 kg / 20.7 lb (DCP-L2531DW) TBD (DCP-L2530DW for LTN)

Specifications are subject to change without notice.

Model	DCP-L2535DW DCP-L2537DW HL-L2390DW	DCP-L2550DN	DCP-7190DN DCP-L2550DW DCP-L2551DW DCP-L2551DN DCP-L2552DN	DCP-7195DW	HL-L2395DW
Warm up Time (From Sleep Mode)	Less than 9 sec. at 73.4F / 50% (23°C / 50%)			Less than 4 sec. at 73.4F / 50% (23°C / 50%)	Less than 9 sec. at 73.4F / 50% (23°C / 50%)
Warm up Time (From Power ON)	Less than 28 sec. at 73.4F / 50% (23°C / 50%)				
F POT (From Ready Mode and Standard Tray)	Less than 8.5 sec. at 73.4F (23°C) / 230V			Less than 7 sec. at 73.4F (23°C) / 230V	Less than 8.5 sec. at 73.4F (23°C) / 230V
F POT (From Sleep Mode and Standard Tray)	Less than 17.5 sec. at 73.4F (23°C) / 230V			Less than 11 sec. at 73.4F (23°C) / 230V	Less than 17.5 sec. at 73.4F (23°C) / 230V
Mono Print Speed (A4/Letter)	Up to 34/36 ppm (Quiet Mode: Up to 13/13 ppm) (DCP-L2535DW)  Up to 30/32 ppm (Quiet Mode: Up to 13/13 ppm) (DCP-L2537DW, HL-L2390DW)	Up to 34/36 ppm (Quiet Mode: Up to 13/13 ppm)			
Full Color Print Speed (A4/Letter)	N/A				
Mono Duplex Print Speed (A4/Letter)	16/17 sides per minute (8/8.5 sheets per minute) (DCP-L2535DW)  15/15 sides per minute (7.5/7.5 sheets per minute) (DCP-L2537DW, HL-L2390DW)	16/17 sides per minute (8/8.5 sheets per minute)			
Full Color Duplex Print Speed (A4/Letter)	N/A				
Processor	600 MHz				
Back up Clock	N/A				
Carton Dimensions (W x D x H)	580 x 517 x 434 mm 22.8" x 20.4" x 17.1"			608 x 517 x 434 mm 23.9" x 20.4" x 17.1"	580 x 517 x 434 mm 22.8" x 20.4" x 17.1"
Machine Dimensions (W x D x H)	410 x 398.5 x 272 mm 16.1" x 15.7" x 10.7"	410 x 398.5 x 318.5 mm 16.1" x 15.7" x 12.5"		410 x 426.5 x 318.5 mm 16.1" x 16.8" x 12.5"	410 x 398.5 x 272 mm 16.1" x 15.7" x 10.7"
Weight w/ Carton	13.1 kg / 28.9 lb (HL-L2390DW) 13.4 kg / 29.6 lb (DCP-L2537DW) 14.8 kg / 32.6 lb (DCP-L2535DW)	14.4 kg / 31.8 lb	14.4 kg / 31.8 lb (DCP-L2550DW for US) 14.5 kg / 32.0 lb (DCP-L2551DN) 14.5 kg / 32.1 lb (DCP-L2551DW for LTN) 14.7 kg / 32.4 lb (DCP-L2552DN) 14.8 kg / 32.6 lb (DCP-L2550DW for ASA) TBD (DCP-7190DN, L2550DW for LTN, L2551DW for ASA)	15.4 kg / 33.9 lb	13.1 kg / 28.9 lb
Weight w/o Carton, w/ toner/drum	10.3 kg / 22.7 lb (DCP-L2537DW, HL-L2390DW) 11.8 kg / 26.0 lb (DCP-L2535DW)	11.6 kg / 25.6 lb	11.6 kg / 25.6 lb (DCP-L2550DW for US, L2551DW for LTN, L2551DN, L2552DN) 11.8 kg / 26.0 lb (DCP-L2550DW for ASA) TBD (DCP-7190DN, L2550DW for LTN, L2551DW for ASA)	12.1 kg / 26.7 lb	10.3 kg / 22.7 lb
Weight w/o Carton and toner/drum	9.2 kg / 20.3 lb (DCP-L2537DW) 9.4 kg / 20.7 lb (HL-L2390DW) 10.5 kg / 23.1 lb (DCP-L2535DW)	10.5 kg / 23.1 lb	10.5 kg / 23.1 lb (DCP-L2550DW for ASA, L2551DN, L2552DN) 10.7 kg / 23.6 lb (DCP-L2550DW for US, L2551DW for LTN) TBD (DCP-7190DN, L2550DW for LTN, L2551DW for ASA)	11.2 kg / 24.7 lb	9.4 kg / 20.7 lb

Specifications are subject to change without notice.

Model	MFC-7390	MFC-7490D	MFC-B7715DW MFC-B7720DN MFC-L2715D MFC-L2716D	MFC-L2690DW MFC-L2710DN MFC-L2710DW MFC-L2712DN MFC-L2712DW	MFC-L2713DW MFC-L2715DW MFC-L2716DW MFC-L2717DW
Warm up Time (From Sleep Mode)	Less than 9 sec. at 73.4F / 50% (23°C / 50%)				
Warm up Time (From Power ON)	Less than 27 sec. at 73.4F / 50% (23°C / 50%)		Less than 27 sec. at 73.4F / 50% (23°C / 50%) (MFC-B7715DW for EU, L2715D, L2716D) Less than 28 sec. at 73.4F / 50% (23°C / 50%) (MFC-B7715DW for ASA, B7720DN)	Less than 28 sec. at 73.4F / 50% (23°C / 50%)	
FPOT (From Ready Mode and Standard Tray)	Less than 8.5 sec. at 73.4F (23°C) / 230V				
FPOT (From Sleep Mode and Standard Tray)	Less than 17.5 sec. at 73.4F (23°C) / 230V				
Mono Print Speed (A4/Letter)	Up to 30/32 ppm (Quiet Mode: Up to 13/13 ppm)		Up to 34/36 ppm (Quiet Mode: Up to 13/13 ppm)	Up to 30/32 ppm (Quiet Mode: Up to 13/13 ppm) (for MFC-L2710DN, L2710DW, L2712DN, L2712DW) Up to 26/26 ppm (Quiet Mode: Up to 13/13 ppm) (for MFC-L2690DW)	Up to 34/36 ppm (Quiet Mode: Up to 13/13 ppm)
Full Color Print Speed (A4/Letter)	N/A				
Mono Duplex Print Speed (A4/Letter)	N/A	15/15 sides per minute (7.5/7.5 sheets per minute)	16/17 sides per minute (8/8.5 sheets per minute)	15/15 sides per minute (7.5/7.5 sheets per minute)	16/17 sides per minute (8/8.5 sheets per minute)
Full Color Duplex Print Speed (A4/Letter)	N/A				
Processor	600 MHz				
Back up Clock	Up to 2 hours				
Carton Dimensions (W x D x H)	580 x 570 x 434 mm 22.8" x 22.4" x 17.1"		580 x 517 x 434 mm 22.8" x 20.4" x 17.1" (except for MFC-B7720DN) 580 x 570 x 434 mm 22.8" x 22.4" x 17.1" (MFC-B7720DN)	580 x 517 x 434 mm 22.8" x 20.4" x 17.1"	
Machine Dimensions (W x D x H)	481 x 398.5 x 318.5 mm 18.9" x 15.7" x 12.5"		410 x 398.5 x 318.5 mm 16.1" x 15.7" x 12.5" (except for MFC-B7720DN) 481 x 398.5 x 318.5 mm 18.9" x 15.7" x 12.5" (MFC-B7720DN)	410 x 398.5 x 318.5 mm 16.1" x 15.7" x 12.5"	
Weight w/ Carton	TBD	TBD	15.0 kg / 33.0 lb (MFC-B7715DW for ASA) 15.1 kg / 33.3 lb (MFC-B7715DW for EU) 15.5 kg / 34.3 lb (MFC-B7720DN) TBD (MFC-L2715D, L2716D)	14.7 kg / 32.5 lb (MFC-L2710DN, L2710DW for US/EU/OCE(ARL)) 14.9 kg / 32.8 lb (MFC-L2712DN, L2712DW) TBD (MFC-L2690DW, L2710DW for LTN)	14.7 kg / 32.5 lb (MFC-L2713DW, L2715DW for TWN, L2717DW) 14.8 kg / 32.6 lb (MFC-L2715DW for KOR, L2716DW) 15.1 kg / 33.3 lb (MFC-L2715DW for ASA)
Weight w/o Carton, w/ toner/drum	TBD	TBD	12.0 kg / 26.5 lb (MFC-B7715DW) 12.1 kg / 26.7 lb (MFC-B7720DN) TBD (MFC-L2715D, L2716D)	11.8 kg / 26.0 lb (except for MFC-L2690DW, L2710DW for LTN) TBD (MFC-L2690DW, L2710DW for LTN)	11.8 kg / 26.0 lb (MFC-L2713DW, L2715DW for KOR/TWN, L2716DW, L2717DW) 12.0 kg / 26.5 lb (MFC-L2715DW for ASA)
Weight w/o Carton and toner/drum	TBD	TBD	10.9 kg / 24.0 lb (MFC-B7715DW for EU) 11.1 kg / 24.5 lb (MFC-B7715DW for ASA) 11.2 kg / 24.7 lb (MFC-B7720DN) TBD (MFC-L2715D, L2716D)	10.7 kg / 23.6 lb (MFC-L2710DN, L2710DW for EU, L2712DN, L2712DW) 10.9 kg / 24.0 lb (MFC-L2710DW for US/ OCE(ARL)) TBD (MFC-L2690DW, L2710DW for LTN)	10.7 kg / 23.6 lb (MFC-L2715DW for ASA) 10.9 kg / 24.0 lb (MFC-L2713DW, L2715DW for KOR/TWN, L2716DW, L2717DW)

Specifications are subject to change without notice.

Model	MFC-L2730DW MFC-L2732DW	MFC-7895DW	MFC-7890DN MFC-B7700D	MFC-L2750DW MFC-L2750DWXL MFC-L2751DW MFC-L2752DW	MFC-L2770DW MFC-L2771DW
Warm up Time (From Sleep Mode)	Less than 9 sec. at 73.4F / 50% (23°C / 50%)	Less than 4.0 sec. at 73.4F / 50% (23°C / 50%)	Less than 9 sec. at 73.4F / 50% (23°C / 50%)		Less than 4.0 sec. at 73.4F / 50% (23°C / 50%)
Warm up Time (From Power ON)	Less than 28 sec. at 73.4F / 50% (23°C / 50%)		Less than 27 sec. at 73.4F / 50% (23°C / 50%) (for MFC-B7700D)	Less than 28 sec. at 73.4F / 50% (23°C / 50%)	
FPOST (From Ready Mode and Standard Tray)	Less than 8.5 sec. at 73.4F (23°C) / 230V	Less than 7 sec. at 73.4F (23°C) / 230V	Less than 8.5 sec. at 73.4F (23°C) / 230V		Less than 7 sec. at 73.4F (23°C) / 230V
FPOST (From Sleep Mode and Standard Tray)	Less than 17.5 sec. at 73.4F (23°C) / 230V	Less than 11 sec. at 73.4F (23°C) / 230V	Less than 17.5 sec. at 73.4F (23°C) / 230V		Less than 11 sec. at 73.4F (23°C) / 230V
Mono Print Speed (A4/Letter)	Up to 34/36 ppm (Quiet Mode: Up to 13/13 ppm)				
Full Color Print Speed (A4/Letter)	N/A				
Mono Duplex Print Speed (A4/Letter)	16/17 sides per minute (8/8.5 sheets per minute)				
Full Color Duplex Print Speed (A4/Letter)	N/A				
Processor	600 MHz				
Back up Clock	Up to 60 hours		Up to 2 hours (for MFC-B7700D) Up to 60 hours (for MFC-7890DN)	Up to 60 hours	
Carton Dimensions (W x D x H)	580 x 517 x 434 mm 22.8" x 20.4" x 17.1"	608 x 570 x 434 mm 23.9" x 22.4" x 17.1"	580 x 570 x 434 mm 22.8" x 22.4" x 17.1"	580 x 517 x 434 mm 22.8" x 20.4" x 17.1"	608 x 570 x 434 mm 23.9" x 22.4" x 17.1"
Machine Dimensions (W x D x H)	410 x 398.5 x 318.5 mm 16.1" x 15.7" x 12.5"	481 x 426.5 x 318.5 mm 18.9" x 16.8" x 12.5"	481 x 398.5 x 318.5 mm 18.9" x 15.7" x 12.5"	410 x 398.5 x 318.5 mm 16.1" x 15.7" x 12.5"	410 x 426.5 x 318.5 mm 18.9" x 16.8" x 12.5"
Weight w/ Carton	14.7 kg / 32.5 lb (MFC-L2730DW for US/EU/OCE) 14.9 kg / 32.8 lb (for MFC-L2732DW) TBD (MFC-L2730DW for LTN)	16.2 kg / 35.8 lb	15.5 kg / 34.3 lb (MFC-B7700D) TBD (MFC-7890DN)	14.9 kg / 32.9 lb (MFC-L2750DW for US/EU/OCE, L2751DW for ASA) 15.0 kg / 33.0 lb (MFC-L2751DW for EU) 15.3 kg / 33.8 lb (MFC-L2750DW for ASA) 15.5 kg / 34.1 lb (MFC-L2750DWXL) TBD (MFC-L2750DW for LTN, L2752DW)	15.9 kg / 35.1 lb (MFC-L2770DW for OCE) 16.0 kg / 35.3 lb (MFC-L2771DW) 16.2 kg / 35.8 lb (MFC-L2770DW for ASA)
Weight w/o Carton, w/ toner/drum	11.8 kg / 26.0 lb (MFC-L2730DW for US/EU/OCE, L2732DW) TBD (MFC-L2730DW for LTN)	12.8 kg / 28.2 lb	12.1 kg / 26.7 lb (MFC-B7700D) TBD (MFC-7890DN)	12.0 kg / 26.5 lb (MFC-L2750DW for US/EU/OCE, L2751DW, L2752DW) 12.2 kg / 26.9 lb (MFC-L2750DW for ASA) 12.6 kg / 27.7 lb (MFC-L2750DWXL) TBD (MFC-L2750DW for LTN)	12.7 kg / 28.0 lb (MFC-L2770DW for OCE, L2771DW) 12.9 kg / 28.4 lb (MFC-L2770DW for ASA)
Weight w/o Carton and toner/drum	10.7 kg / 23.6 lb (MFC-L2730DW for EU, L2732DW) 10.9 kg / 24.0 lb (MFC-L2730DW for US/OCE) TBD (MFC-L2730DW for LTN)	11.9 kg / 26.2 lb	11.2 kg / 24.7 lb (MFC-B7700D) TBD (MFC-7890DN)	10.9 kg / 24.0 lb (MFC-L2750DW for EU/ASA, L2751DW for EU, L2752DW) 11.1 kg / 24.5 lb (MFC-L2750DW for US/OCE, L2750DWXL, L2751DW for ASA) TBD (MFC-L2750DW for LTN)	11.6 kg / 25.6 lb (MFC-L2770DW for ASA, L2771DW) 11.8 kg / 26.0 lb (MFC-L2770DW for OCE)

Specifications are subject to change without notice.

## 2. NETWORK CONNECTIVITY

Model		DCP-7090 DCP-7095D DCP-B7500D DCP-L2510D DCP-L2511D DCP-L2512D DCP-L2535D DCP-L2536D	DCP-B7520DW	DCP-L2530DW DCP-L2531DW DCP-L2532DW DCP-L2535DW DCP-L2537DW HL-L2390DW	DCP-7190DN DCP-B7530DN DCP-L2550DN DCP-L2551DN DCP-L2552DN
Wired network	Network node type	N/A	NC-9300h type2	N/A	NC-9300h type2
Wireless network	Network node type	N/A	NC-8800w type2		N/A

Model		DCP-7195DW DCP-B7535DW DCP-L2550DW DCP-L2551DW	HL-L2395DW	MFC-7390 MFC-7490D MFC-B7700D MFC-L2715D MFC-L2716D	MFC-B7720DN MFC-L2710DN MFC-L2712DN
Wired network	Network node type	NC-9300h type2		N/A	NC-9300h type2
Wireless network	Network node type	NC-8800w type2		N/A	

Model		MFC-L2690DW	MFC-B7715DW MFC-L2710DW MFC-L2712DW MFC-L2713DW MFC-L2715DW MFC-L2716DW MFC-L2717DW	MFC-7890DN	MFC-L2730DW MFC-L2732DW	MFC-7895DW MFC-L2750DW MFC-L2750DWXL MFC-L2751DW MFC-L2752DW MFC-L2770DW MFC-L2771DW
Wired network	Network node type	N/A	NC-9300h type2			
Wireless network	Network node type	NC-8800w type2		N/A	NC-8800w type2	

Specifications are subject to change without notice.

### 3. SERVICE INFORMATION

Model	DCP-7090 DCP-7095D DCP-B7500D DCP-B7520DW DCP-L2510D DCP-L2511D DCP-L2512D DCP-L2530DW DCP-L2531DW DCP-L2532DW DCP-L2535D DCP-L2535DW DCP-L2536D DCP-L2537DW HL-L2390DW	DCP-7190DN DCP-B7530DN DCP-B7535DW DCP-L2550DN DCP-L2550DW DCP-L2551DN DCP-L2551DW DCP-L2552DN	DCP-7195DW	HL-L2395DW
Machine life	50,000 pages (A4/LTR) or 5 years			
Part life (ADF)	N/A	50,000 pages or 5 years		N/A
Part life (Document scanner unit)	50,000 pages or 5 years			
MTBF	4,000 hours			
MTTR	0.5 hours			
Maximum monthly volume	Up to 15,000 pages			
Maintenance parts life (Non-Periodical Spare Parts)	Fuser unit	50,000 pages		
	Laser unit	50,000 pages		
	PF kit 1	50,000 pages		
	PF kit MP	N/A	50,000 pages	N/A

Specifications are subject to change without notice.

Model	MFC-7390 MFC-7490D MFC-B7700D MFC-B7715DW MFC-B7720DN MFC-L2690DW MFC-L2710DN MFC-L2710DW MFC-L2712DN MFC-L2712DW MFC-L2713DW MFC-L2715D MFC-L2715DW MFC-L2716D MFC-L2716DW MFC-L2717DW	MFC-7890DN MFC-L2730DW MFC-L2732DW	MFC-7895DW MFC-L2770DW MFC-L2771DW	MFC-L2750DW MFC-L2750DWXL MFC-L2751DW MFC-L2752DW
Machine life	50,000 pages (A4/LTR) or 5 years			
Part life (ADF)	50,000 pages or 5 years			
Part life (Document scanner unit)	50,000 pages or 5 years			
MTBF	4,000 hours			
MTTR	0.5 hours			
Maximum monthly volume	Up to 15,000 pages			
Maintenance parts life (Non-Periodical Spare Parts)	Fuser unit	50,000 pages		
	Laser unit	50,000 pages		
	PF kit 1	50,000 pages		
	PF kit MP	N/A	50,000 pages	N/A

Specifications are subject to change without notice.

## 4. SUPPLIES

Model		DCP-7090 DCP-7095D	DCP-B7500D DCP-B7520DW	DCP-L2510D DCP-L2512D DCP-L2530DW DCP-L2532DW HL-L2390DW	DCP-L2511D DCP-L2531DW
Toner cartridge	Starter Toner <sup>*1</sup>	3,000 pages in accordance with ISO/IEC 19752	2,600 pages (Toner Bottle) in accordance with ISO/IEC 19752 (except for DCP-B7520DW for EU)  2,000 pages (Toner Bottle) in accordance with ISO/IEC 19752 (DCP-B7520DW for EU)	700 pages in accordance with ISO/IEC 19752	3,000 pages in accordance with ISO/IEC 19752 (for IND)
	Standard Toner	1,200 pages in accordance with ISO/IEC 19752	N/A	1,200 pages in accordance with ISO/IEC 19752	N/A
	High Capacity Toner	3,000 pages in accordance with ISO/IEC 19752	N/A	3,000 pages in accordance with ISO/IEC 19752	
	Super High Capacity Toner	N/A		4,500 pages in accordance with ISO/IEC 19752	
When printing A4/Letter size one sided pages in accordance with ISO/IEC 19752 Shelf life: 2 years without opening (6 months after opening)					
Drum unit	Life expectancy: Approximately 12,000 pages (1 page/job) The life expectancy varies according to the use condition. Shelf life: 2 years				
The shelf life of toner cartridge and drum unit is guaranteed under the normal condition as below; (Temperature) Normal condition: 0 to 40°C (Humidity) Normal condition: 35%RH to 85%RH (without condensation) * Storage condition at the temperature of 50°C: Up to 5 days * Storage condition at the temperature of -20°C: Up to 5 days					

<sup>\*1</sup> Toner supplied with the machine.

Specifications are subject to change without notice.



Model		DCP-L2535D	DCP-L2535DW DCP-L2537DW	DCP-L2536D	DCP-7190DN
Toner cartridge	Starter Toner *1	1,200 pages in accordance with ISO/IEC 19752 (for ASA)  3,000 pages in accordance with ISO/IEC 19752 (for PHL)	1,200 pages in accordance with ISO/IEC 19752	3,000 pages in accordance with ISO/IEC 19752 (for VNM/IDN)	3,000 pages in accordance with ISO/IEC 19752
	Standard Toner	1,200 pages in accordance with ISO/IEC 19752			
	High Capacity Toner	3,000 pages in accordance with ISO/IEC 19752			
	Super High Capacity Toner	N/A	4,500 pages in accordance with ISO/IEC 19752	N/A	
When printing A4/Letter size one sided pages in accordance with ISO/IEC 19752 Shelf life: 2 years without opening (6 months after opening)					
Drum unit	Life expectancy: Approximately 12,000 pages (1 page/job) The life expectancy varies according to the use condition. Shelf life: 2 years				
The shelf life of toner cartridge and drum unit is guaranteed under the normal condition as below; (Temperature) Normal condition: 0 to 40°C (Humidity) Normal condition: 35%RH to 85%RH (without condensation) * Storage condition at the temperature of 50°C: Up to 5 days * Storage condition at the temperature of -20°C: Up to 5 days					

\*1 Toner supplied with the machine.

Specifications are subject to change without notice.

Model		DCP-7195DW DCP-L2550DN DCP-L2552DN	DCP-B7530DN DCP-B7535DW	DCP-L2550DW	DCP-L2551DN
Toner cartridge	Starter Toner <sup>*1</sup>	3,000 pages in accordance with ISO/IEC 19752	2,600 pages (Toner Bottle) in accordance with ISO/IEC 19752	700 pages in accordance with ISO/IEC 19752 (for US/LTN)  1,200 pages in accordance with ISO/IEC 19752 (for ASA)  3,000 pages in accordance with ISO/IEC 19752 (for GULF/PHL)  700 pages (for TWN)	4,500 pages in accordance with ISO/IEC 19752
	Standard Toner	1,200 pages in accordance with ISO/IEC 19752	N/A	1,200 pages in accordance with ISO/IEC 19752	N/A
	High Capacity Toner	3,000 pages in accordance with ISO/IEC 19752	N/A	3,000 pages in accordance with ISO/IEC 19752	
	Super High Capacity Toner	4,500 pages in accordance with ISO/IEC 19752	N/A	4,500 pages in accordance with ISO/IEC 19752	
When printing A4/Letter size one sided pages in accordance with ISO/IEC 19752 Shelf life: 2 years without opening (6 months after opening)					
Drum unit		Life expectancy: Approximately 12,000 pages (1 page/job) The life expectancy varies according to the use condition. Shelf life: 2 years			
The shelf life of toner cartridge and drum unit is guaranteed under the normal condition as below; (Temperature) Normal condition: 0 to 40°C (Humidity) Normal condition: 35%RH to 85%RH (without condensation) * Storage condition at the temperature of 50°C: Up to 5 days * Storage condition at the temperature of -20°C: Up to 5 days					

<sup>\*1</sup> Toner supplied with the machine.

Specifications are subject to change without notice.

Model		DCP-L2551DW	HL-L2395DW	MFC-7390 MFC-7490D	MFC-B7700D MFC-B7720DN
Toner cartridge	Starter Toner <sup>*1</sup>	3,000 pages in accordance with ISO/IEC 19752 (for IND/VNM/IDN)  N/A (for LTN)	700 pages in accordance with ISO/IEC 19752	3,000 pages in accordance with ISO/IEC 19752	2,600 pages (Toner Bottle) in accordance with ISO/IEC 19752
	Standard Toner	1,200 pages in accordance with ISO/IEC 19752			N/A
	High Capacity Toner	3,000 pages in accordance with ISO/IEC 19752			N/A
	Super High Capacity Toner	4,500 pages in accordance with ISO/IEC 19752	4,500 pages in accordance with ISO/IEC 19752 (for US)  N/A (for OCE)	N/A	
When printing A4/Letter size one sided pages in accordance with ISO/IEC 19752 Shelf life: 2 years without opening (6 months after opening)					
Drum unit	Life expectancy: Approximately 12,000 pages (1 page/job) The life expectancy varies according to the use condition. Shelf life: 2 years				
The shelf life of toner cartridge and drum unit is guaranteed under the normal condition as below; (Temperature) Normal condition: 0 to 40°C (Humidity) Normal condition: 35%RH to 85%RH (without condensation) * Storage condition at the temperature of 50°C: Up to 5 days * Storage condition at the temperature of -20°C: Up to 5 days					

<sup>\*1</sup> Toner supplied with the machine.

Specifications are subject to change without notice.

Model		MFC-B7715DW	MFC-L2690DW MFC-L2710DN MFC-L2712DN MFC-L2712DW	MFC-L2710DW MFC-L2713DW	MFC-L2715D
Toner cartridge	Starter Toner *1	2,000 pages (Toner Bottle) in accordance with ISO/IEC 19752	700 pages in accordance with ISO/IEC 19752		1,200 pages in accordance with ISO/IEC 19752 (for ASA)  3,000 pages in accordance with ISO/IEC 19752 (for KOR/PHL)
	Standard Toner	N/A	1,200 pages in accordance with ISO/IEC 19752		
	High Capacity Toner	N/A	3,000 pages in accordance with ISO/IEC 19752		
	Super High Capacity Toner	N/A	4,500 pages in accordance with ISO/IEC 19752	4,500 pages in accordance with ISO/IEC 19752 (for EU/US/LTN)  N/A (for OCE)	N/A
When printing A4/Letter size one sided pages in accordance with ISO/IEC 19752 Shelf life: 2 years without opening (6 months after opening)					
Drum unit	Life expectancy: Approximately 12,000 pages (1 page/job) The life expectancy varies according to the use condition. Shelf life: 2 years				
The shelf life of toner cartridge and drum unit is guaranteed under the normal condition as below; (Temperature) Normal condition: 0 to 40°C (Humidity) Normal condition: 35%RH to 85%RH (without condensation) * Storage condition at the temperature of 50°C: Up to 5 days * Storage condition at the temperature of -20°C: Up to 5 days					

\*1 Toner supplied with the machine.

Specifications are subject to change without notice.

Model		MFC-L2715DW	MFC-L2716D	MFC-L2716DW	MFC-L2717DW
Toner cartridge	Starter Toner *1	1,200 pages in accordance with ISO/IEC 19752 (for ASA)  3,000 pages in accordance with ISO/IEC 19752 (for GULF/PHL)  700 pages (for TWN)	3,000 pages in accordance with ISO/IEC 19752 (for IND/VNM/IDN)	3,000 pages in accordance with ISO/IEC 19752 (for IND/TUR/VNM/IDN)	1,200 pages in accordance with ISO/IEC 19752
	Standard Toner	1,200 pages in accordance with ISO/IEC 19752			
	High Capacity Toner	3,000 pages in accordance with ISO/IEC 19752			
	Super High Capacity Toner	4,500 pages in accordance with ISO/IEC 19752			
When printing A4/Letter size one sided pages in accordance with ISO/IEC 19752 Shelf life: 2 years without opening (6 months after opening)					
Drum unit	Life expectancy: Approximately 12,000 pages (1 page/job) The life expectancy varies according to the use condition. Shelf life: 2 years				
The shelf life of toner cartridge and drum unit is guaranteed under the normal condition as below; (Temperature) Normal condition: 0 to 40°C (Humidity) Normal condition: 35%RH to 85%RH (without condensation) * Storage condition at the temperature of 50°C: Up to 5 days * Storage condition at the temperature of -20°C: Up to 5 days					

\*1 Toner supplied with the machine.

Specifications are subject to change without notice.

Model		MFC-7890DN	MFC-L2730DW MFC-L2732DW	MFC-7895DW	MFC-L2750DW MFC-L2750DWXL
Toner cartridge	Starter Toner * <sup>1</sup>	3,000 pages in accordance with ISO/IEC 19752	700 pages in accordance with ISO/IEC 19752 (MFC-L2730DW for US/LTN/OCE)  1,200 pages in accordance with ISO/IEC 19752 (MFC-L2730DW for EU, L2732DW)	3,000 pages in accordance with ISO/IEC 19752	700 pages in accordance with ISO/IEC 19752 (MFC-L2750DW for US/LTN/OCE/TWN)  1,200 pages in accordance with ISO/IEC 19752 (MFC-L2750DW for EU)  3,000 pages in accordance with ISO/IEC 19752 (MFC-L2750DW for ASA/PHL/GULF)  7,500 pages in accordance with ISO/IEC 19752 (TN-760+TN-770) (for MFC-L2750DWXL)
	Standard Toner	1,200 pages in accordance with ISO/IEC 19752			
	High Capacity Toner	3,000 pages in accordance with ISO/IEC 19752			
	Super High Capacity Toner	N/A	4,500 pages in accordance with ISO/IEC 19752 (MFC-L2730DW for US/LTN/EU, L2732DW)  N/A (MFC-L2730DW for OCE)	4,500 pages in accordance with ISO/IEC 19752	4,500 pages in accordance with ISO/IEC 19752 (except for MFC-L2750DW for OCE)  N/A (MFC-L2750DW for OCE)
When printing A4/Letter size one sided pages in accordance with ISO/IEC 19752 Shelf life: 2 years without opening (6 months after opening)					
Drum unit	Life expectancy: Approximately 12,000 pages (1 page/job) The life expectancy varies according to the use condition. Shelf life: 2 years				
The shelf life of toner cartridge and drum unit is guaranteed under the normal condition as below; (Temperature) Normal condition: 0 to 40°C (Humidity) Normal condition: 35%RH to 85%RH (without condensation) * Storage condition at the temperature of 50°C: Up to 5 days * Storage condition at the temperature of -20°C: Up to 5 days					

\*<sup>1</sup> Toner supplied with the machine.

Specifications are subject to change without notice.

Model		MFC-L2751DW	MFC-L2752DW	MFC-L2770DW	MFC-L2771DW
Toner cartridge	Starter Toner <sup>*1</sup>	4,500 pages in accordance with ISO/IEC 19752 (for TUR)  N/A (for EU)	1,200 pages in accordance with ISO/IEC 19752	3,000 pages in accordance with ISO/IEC 19752 (for ASA)  4,500 pages in accordance with ISO/IEC 19752 (for KOR/PHL)  700 pages (for TWN)  N/A (for OCE)	4,500 pages in accordance with ISO/IEC 19752 (for TUR)  3,000 pages in accordance with ISO/IEC 19752 (for VNM/IDN)
	Standard Toner	N/A	1,200 pages in accordance with ISO/IEC 19752		
	High Capacity Toner	3,000 pages in accordance with ISO/IEC 19752			
	Super High Capacity Toner	4,500 pages in accordance with ISO/IEC 19752			
When printing A4/Letter size one sided pages in accordance with ISO/IEC 19752 Shelf life: 2 years without opening (6 months after opening)					
Drum unit	Life expectancy: Approximately 12,000 pages (1 page/job) The life expectancy varies according to the use condition. Shelf life: 2 years				
The shelf life of toner cartridge and drum unit is guaranteed under the normal condition as below; (Temperature) Normal condition: 0 to 40°C (Humidity) Normal condition: 35%RH to 85%RH (without condensation) * Storage condition at the temperature of 50°C: Up to 5 days * Storage condition at the temperature of -20°C: Up to 5 days					

<sup>\*1</sup> Toner supplied with the machine.

Specifications are subject to change without notice.

## 5. MEDIA SPECIFICATIONS

Model		DCP-7090 DCP-7095D DCP-B7500D DCP-B7520DW DCP-L2510D DCP-L2511D DCP-L2512D DCP-L2530DW DCP-L2531DW DCP-L2532DW DCP-L2535D DCP-L2535DW DCP-L2536D DCP-L2537DW HL-L2390DW HL-L2395DW	DCP-7190DN DCP-7195DW DCP-B7530DN DCP-B7535DW DCP-L2550DN DCP-L2550DW DCP-L2551DN DCP-L2551DW DCP-L2552DN
Media types	ADF	N/A	Plain Paper, Recycled Paper
Paper input	ADF	N/A	50 sheets
Media weight	ADF	N/A	64 to 105 g/m <sup>2</sup> (17 to 28 lb)
Media size	ADF	N/A	Width 105 to 215.9 mm, Length 147.3 to 355.6 mm

Model		MFC-7390 MFC-7490D MFC-B7700D MFC-B7715DW MFC-B7720DN MFC-L2690DW MFC-L2710DN MFC-L2710DW MFC-L2712DN MFC-L2712DW MFC-L2713DW MFC-L2715D MFC-L2715DW MFC-L2716D MFC-L2716DW MFC-L2717DW	MFC-7890DN MFC-L2730DW MFC-L2732DW	MFC-7895DW MFC-L2750DW MFC-L2750DWXL MFC-L2751DW MFC-L2752DW MFC-L2770DW MFC-L2771DW
Media types	ADF	Plain Paper, Recycled Paper		
Paper input	ADF	50 sheets		
Media weight	ADF	60 to 105 g/m <sup>2</sup> (16 to 28 lb)		
Media size	ADF	Width 105 to 215.9 mm, Length 147.3 to 355.6 mm		

Specifications are subject to change without notice.



## 6. FAX (ONLY FOR THE MODELS WITH FAX FUNCTION)

Model	DCP-7090 DCP-7095D DCP-B7500D DCP-B7520DW DCP-L2510D DCP-L2511D DCP-L2512D DCP-L2530DW DCP-L2531DW DCP-L2532DW DCP-L2535D DCP-L2535DW DCP-L2536D DCP-L2537DW HL-L2390DW	DCP-7190DN DCP-7195DW DCP-B7530DN DCP-B7535DW DCP-L2550DN DCP-L2550DW DCP-L2551DN DCP-L2551DW DCP-L2552DN	HL-L2395DW
Modem speed	N/A		
Transmission speed	N/A		
ITU-T group	N/A		
Color FAX (Sending/Receiving)	N/A		
Color FAX/Memory (Send/Receive)	N/A		
Internet FAX (ITU T.37 simple mode)	N/A		
Internet FAX (ITU T.38)	N/A		

Model	MFC-7390 MFC-7490D MFC-B7700D MFC-B7715DW MFC-B7720DN MFC-L2690DW MFC-L2710DN MFC-L2710DW MFC-L2712DN MFC-L2712DW MFC-L2713DW MFC-L2715D MFC-L2715DW MFC-L2716D MFC-L2716DW MFC-L2717DW	MFC-7890DN MFC-L2730DW MFC-L2732DW	MFC-7895DW MFC-L2750DW MFC-L2750DWXL MFC-L2751DW MFC-L2752DW MFC-L2770DW MFC-L2771DW
Modem speed	33,600 bps (FAX)		
Transmission speed	Approx. 2.5 sec. (ITU-T Test Chart, Std resolution, JBIG)		
ITU-T group	Super G3		
Color FAX (Sending/Receiving)	N/A		
Color FAX/Memory (Send/Receive)	N/A		
Internet FAX (ITU T.37 simple mode)	Yes (by SST) (for MFC-B7720DN)  N/A (except for MFC-B7720DN)	Yes (by SST)	
Internet FAX (ITU T.38)	N/A		

Specifications are subject to change without notice.

## 7. COPY

Model		DCP-7090 DCP-7095D DCP-L2510D DCP-L2511D DCP-L2512D DCP-L2530DW DCP-L2531DW DCP-L2532DW DCP-L2537DW HL-L2390DW DCP-B7500D DCP-B7520DW DCP-L2535D DCP-L2535DW DCP-L2536D	DCP-7190DN DCP-7195DW DCP-B7530DN DCP-B7535DW DCP-L2550DN DCP-L2550DW DCP-L2551DN DCP-L2551DW DCP-L2552DN	HL-L2395DW
Copy speed (A4/Letter)		Up to 30/32 cpm (for DCP-7090, 7095D, L2510D, L2511D, L2512D, L2530DW, L2531DW, L2532DW, L2537DW, HL-L2390DW)  Up to 34/36 cpm (for DCP-B7500D, B7520DW, L2535D, L2535DW, L2536D)	Up to 34/36 cpm	
First copy out time	From Ready mode and Paper tray	Less than 10 secs	Less than 10 secs (except for DCP-7195DW)  Less than 9 secs (for DCP-7195DW)	Less than 10 secs
	From Sleep mode and Paper tray	Less than 19 secs	Less than 19 secs (except for DCP-7195DW)  Less than 13 secs (for DCP-7195DW)	Less than 19 secs
Print resolution (dpi)		600 x 600 dpi		
Auto duplex scanning copy		N/A		

Specifications are subject to change without notice.

Model		MFC-7390 MFC-7490D MFC-L2710DN MFC-L2710DW MFC-L2712DN MFC-L2712DW MFC-B7700D MFC-B7715DW MFC-B7720DN MFC-L2713DW MFC-L2715D MFC-L2715DW MFC-L2716D MFC-L2716DW MFC-L2690DW MFC-L2717DW	MFC-7890DN MFC-L2730DW MFC-L2732DW	MFC-7895DW MFC-L2770DW MFC-L2771DW MFC-L2750DW MFC-L2750DWXL MFC-L2751DW MFC-L2752DW
Copy speed (A4/Letter)		Up to 30/32 cpm (for MFC-7390, 7490D, L2710DN, L2710DW, L2712DN, L2712DW)  Up to 34/36 cpm (for MFC-B7700D, B7715DW, B7720DN, L2713DW, L2715D, L2715DW, L2716D, L2716DW)  Up to 26/26 cpm (for MFC-L2690DW)  Up to 34/34 cpm (for MFC-L2717DW)	Up to 34/36 cpm	
First copy out time	From Ready mode and Paper tray	Less than 10 secs		Less than 10 secs (for MFC-L2750DW, L2750DWXL, L2751DW, L2752DW)  Less than 9 secs (for MFC-7895DW, L2770DW, L2771DW)
	From Sleep mode and Paper tray	Less than 19 secs		Less than 19 secs (for MFC-L2750DW, L2750DWXL, L2751DW, L2752DW)  Less than 13 secs (for MFC-7895DW, L2770DW, L2771DW)
Print resolution (dpi)		600 x 600 dpi		
Auto duplex scanning copy		N/A		Yes

Specifications are subject to change without notice.

## 8. SCANNER

Model		DCP-7090 DCP-7095D DCP-B7500D DCP-B7520DW DCP-L2510D DCP-L2511D DCP-L2512D DCP-L2530DW DCP-L2531DW DCP-L2532DW DCP-L2535D DCP-L2535DW DCP-L2536D DCP-L2537DW HL-L2390DW	DCP-7190DN DCP-7195DW DCP-B7530DN DCP-B7535DW DCP-L2550DN DCP-L2550DW DCP-L2551DN DCP-L2551DW DCP-L2552DN	HL-L2395DW
Resolution (Optical)	FB	Max. 1,200 x 1,200 dpi		
	ADF	N/A	Max. 600 x 600 dpi	N/A
Resolution (Interpolated)		Max. 19,200 x 19,200 dpi		
Scanning speed (Mono/Color) Multiple sheets In accordance with ISO/IEC17991	Single (images / minute)	N/A	A4: 22.5/7.5 LTR: 23.6/7.9	N/A
	Duplex (images / minute)	N/A		

Model		MFC-7390 MFC-7490D MFC-B7700D MFC-B7715DW MFC-B7720DN MFC-L2690DW MFC-L2710DN MFC-L2710DW MFC-L2712DN MFC-L2712DW MFC-L2713DW MFC-L2715D MFC-L2715DW MFC-L2716D MFC-L2716DW MFC-L2717DW	MFC-7890DN MFC-L2730DW MFC-L2732DW	MFC-7895DW MFC-L2750DW MFC-L2750DWXL MFC-L2751DW MFC-L2752DW MFC-L2770DW MFC-L2771DW
Resolution (Optical)	FB	Max. 1,200 x 1,200 dpi		
	ADF	Max. 600 x 600 dpi		
Resolution (Interpolated)		Max. 19,200 x 19,200 dpi		
Scanning speed (Mono/Color) Multiple sheets In accordance with ISO/IEC17991	Single (images / minute)	A4: 22.5/7.5 LTR: 23.6/7.9		
	Duplex (images / minute)	N/A	A4: 22.5/7.5 LTR: 23.6/7.9	

Specifications are subject to change without notice.

---

# CHAPTER 2 ERROR INDICATIONS AND TROUBLESHOOTING

---

## 1. INTRODUCTION

---

Troubleshooting is the countermeasure procedures that the service personnel should follow if an error or malfunction occurs with the machine. It is impossible to anticipate all of the possible troubles which may occur in future and determine the troubleshooting procedures, so this chapter covers some sample troubles. However, those samples will help the service personnel pinpoint and repair other defective elements.

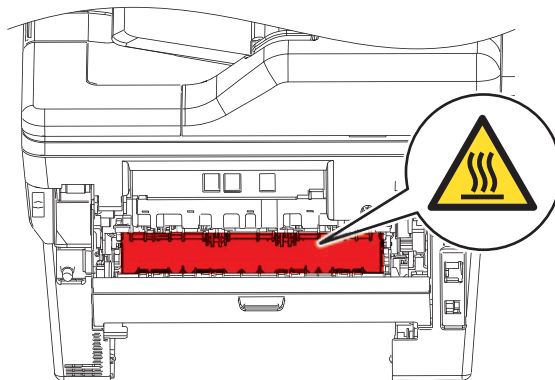
### 1.1 Precautions

Be sure to observe and follow all the precautions to prevent any secondary problems from happening during troubleshooting.

- (1) Always turn OFF the power and unplug the power cable before removing any covers or PCBs, adjusting the machine and so on. If you need to take voltage measurements with the power switched on, take the greatest of care not to receive an electric shock.
- (2) When connecting or disconnecting cable connectors, make sure that you hold the connector body and not the cables.
- (3) Static electricity charged in your body may damage electronic parts. Before handling the PCBs, touch a metal portion of the machine to discharge static electricity charged in your body. When transporting PCBs, be sure to wrap them in conductive sheets. When replacing the PCBs, put on a grounding wrist band and perform the job on an antistatic mat. Also take care not to touch the conductor sections on the flat cables.
- (4) Follow the warning by all means.

**⚠ Warning**

Hazard labels as shown below are attached to the machine. Fully understand the descriptions on the hazard labels and observe them during troubleshooting. Take extreme care not to remove or damage the hazard labels.



 **Warning**

**DO NOT** use any flammable spray or flammable solvent such as alcohol, benzine, or thinner in or around the machine. Otherwise a fire or electric shock may result.



- (5) Check again that the portions and parts repaired or removed during the repair work function properly when the repair is completed.

A certain interface or function could be set to invalid to serve the needs of customers. Ask sales representative if this is the case before performing the check.

## 1.2 Checks before Commencing Troubleshooting

Check the following items before attempting to repair the machine.

### ■ Operating environment

- (1) The machine is placed on a flat, stable surface.
- (2) The machine is used in a clean environment where the temperature is between 10°C (50°F) and 32°C (89.6°F) and the relative humidity is maintained between 20% and 80%.
- (3) Ensure the machine is not exposed to direct sunlight, excessive heat, moisture, or dust.
- (4) Keep the machine horizontal when you carry it. To prevent injuries when moving or lifting this machine, make sure to use at least two people.

### ■ Power supply

- (1) The AC input power supply described on the rating plate of the machine should be within  $\pm 10\%$  of the rated voltage.
- (2) The AC input power supply is within the regulated value.
- (3) The cables and harnesses are connected correctly.
- (4) The fuses are not blown.

### ■ Paper

- (1) A recommended type of paper is being used.
- (2) The paper is not damp.
- (3) The paper is not short-grained paper or acid paper.

### ■ Consumable parts

- (1) The drum unit (including the toner cartridge and toner box) is installed correctly.

### ■ Others

- (1) Condensation

When the machine is moved from a cold place into a warm room, condensation may occur inside the machine, causing various problems as listed below.

- Condensation on the surface of optical devices such as the lens, reflecting mirror, and protection glass, etc., may cause light print image.
- If the exposure drum is cold, the electrical resistance of the photosensitive layer is increased, making it impossible to obtain the correct contrast when printing.
- Condensation on the charge unit may cause corona charge leakage.
- Condensation on the plate and separation pad may cause paper feed problems.

If condensation has occurred, leave the machine for at least two hours to allow it to reach room temperature.

If the drum unit is unpacked soon after it is moved to a warm room from a cold location, condensation may occur inside the unit which may cause printing failure. Leave the drum unit for one or two hours until it reaches room temperature, and then unpack it.

- (2) Low temperature

The motor may not drive normally under the low temperature environment. This is due to there being too much load to drive each unit. In this case, increase the room temperature.

■ **Cleaning**

Use a soft dry lint-free cloth.

 **Warning**

**DO NOT** use any flammable spray or flammable solvent such as alcohol, benzene, or thinner to clean the machine. **DO NOT** use these articles near the machine.





# 2. OVERVIEW

## 2.1 Cross-section Drawing

### 2.1.1 Printer part

#### ■ Manual feed slot models

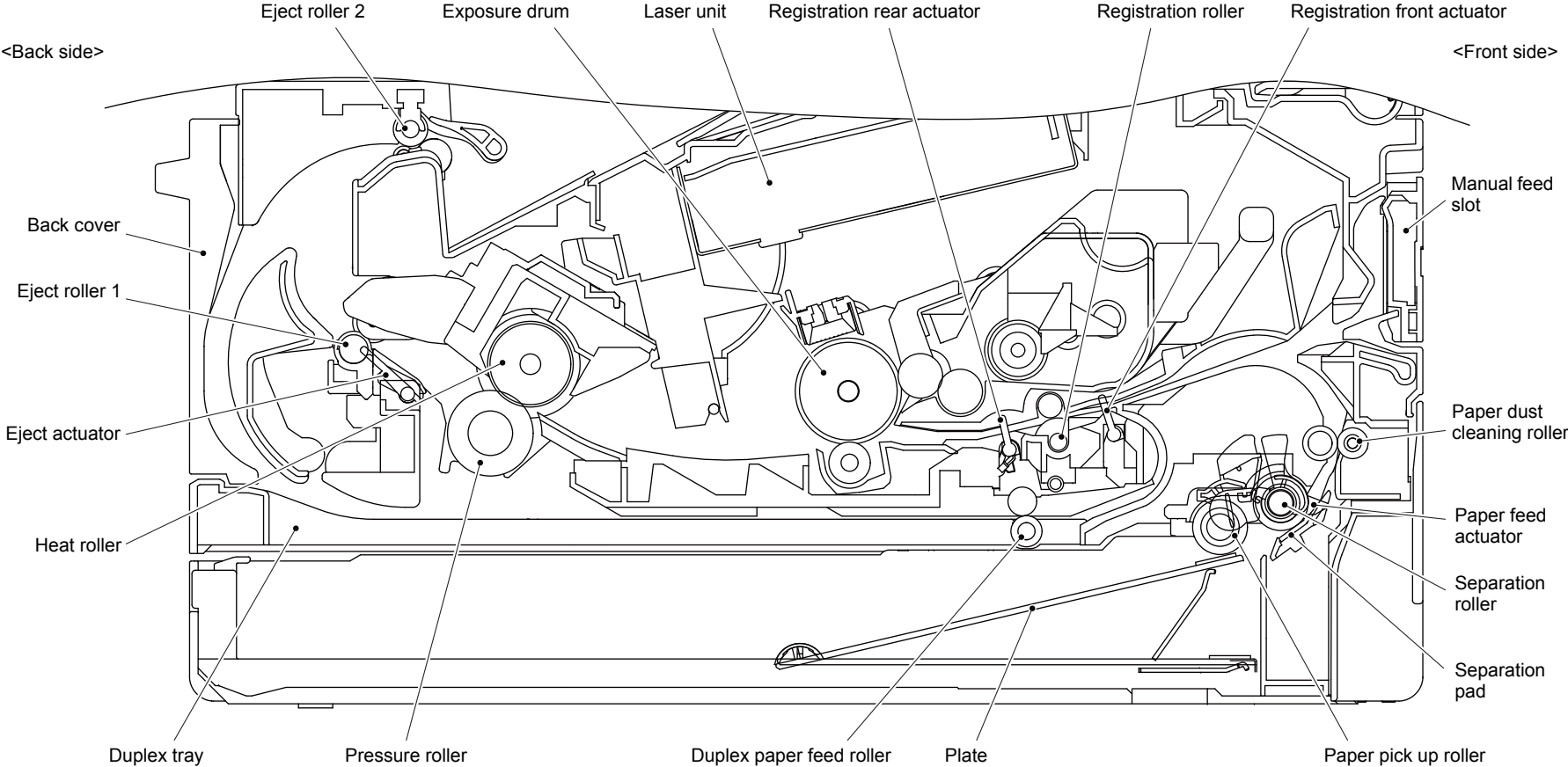


Fig. 2-1

■ MP models

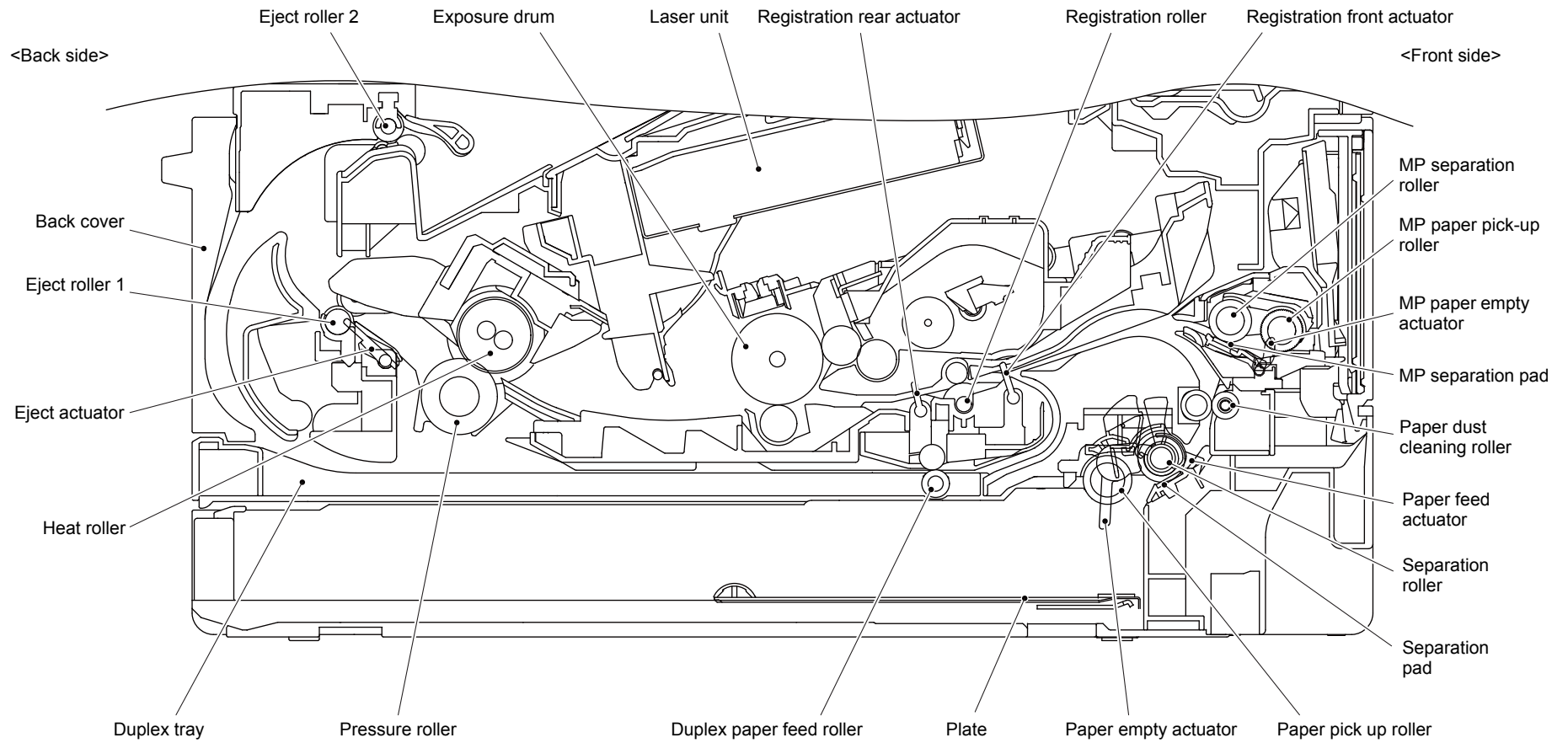


Fig. 2-2

2.1.2 Scanner part

■ SX models

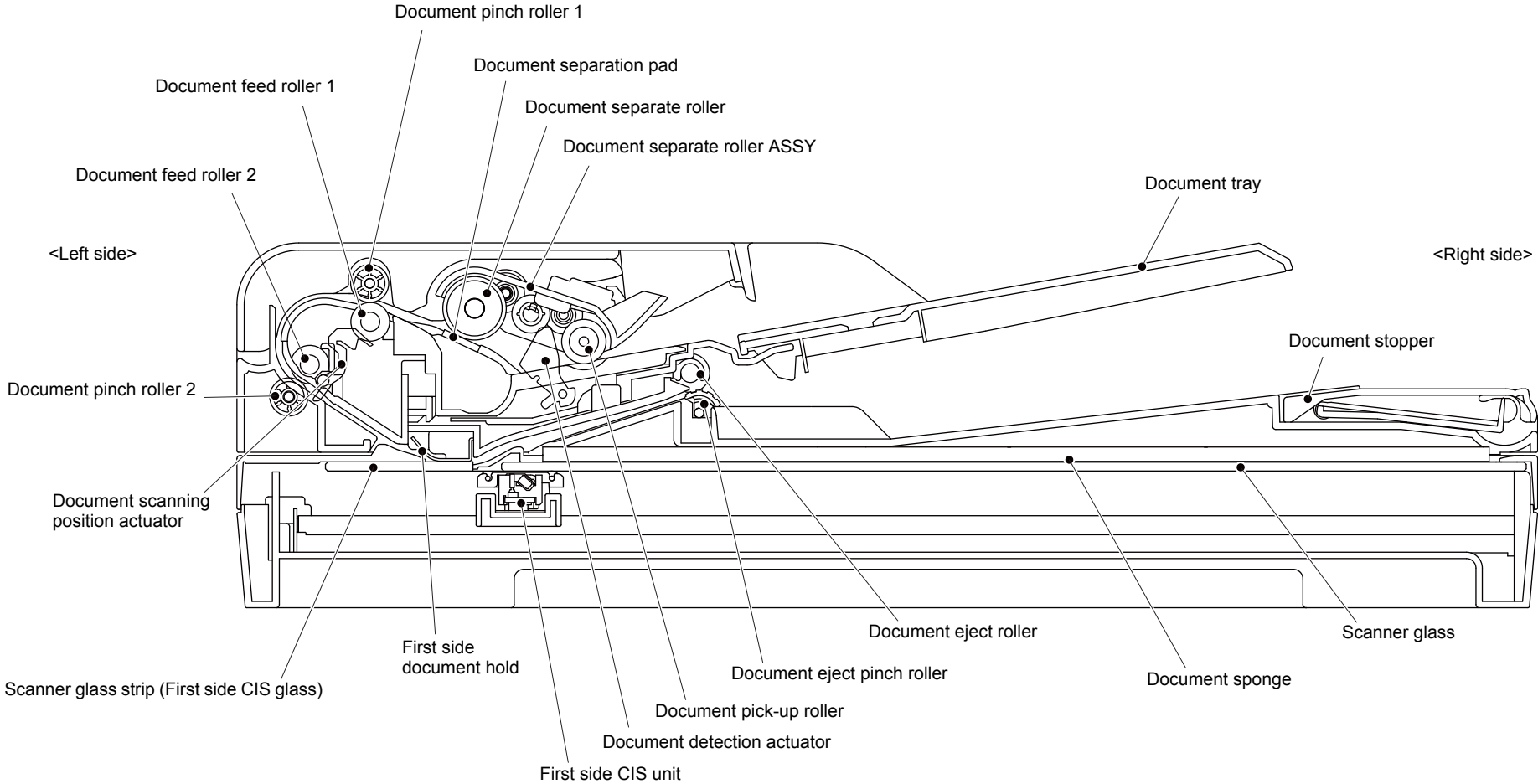


Fig. 2-3

■ DX models

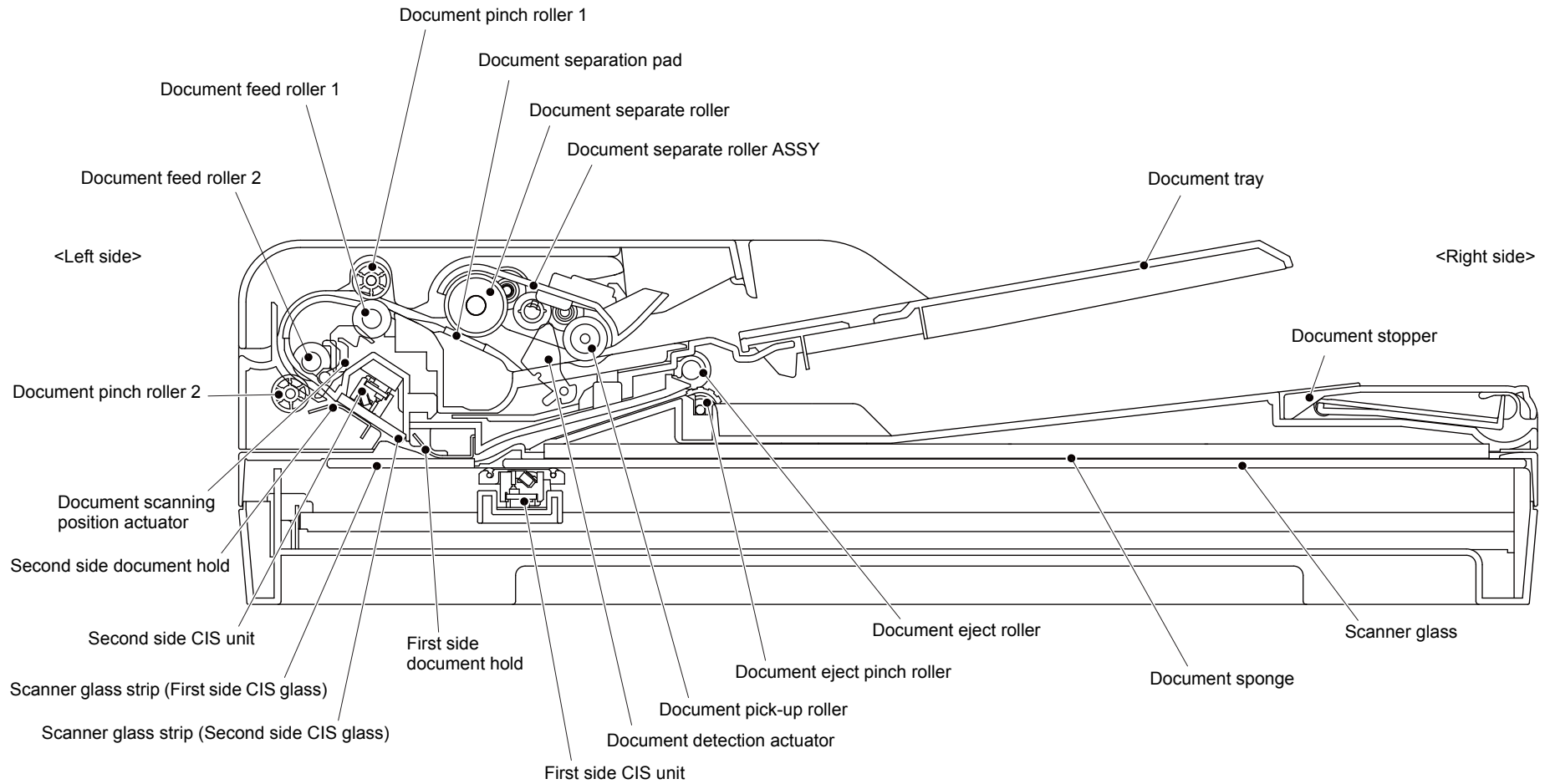


Fig. 2-4

# 2.2 Paper Feeding

## 2.2.1 Printer part

### ■ Manual feed slot models

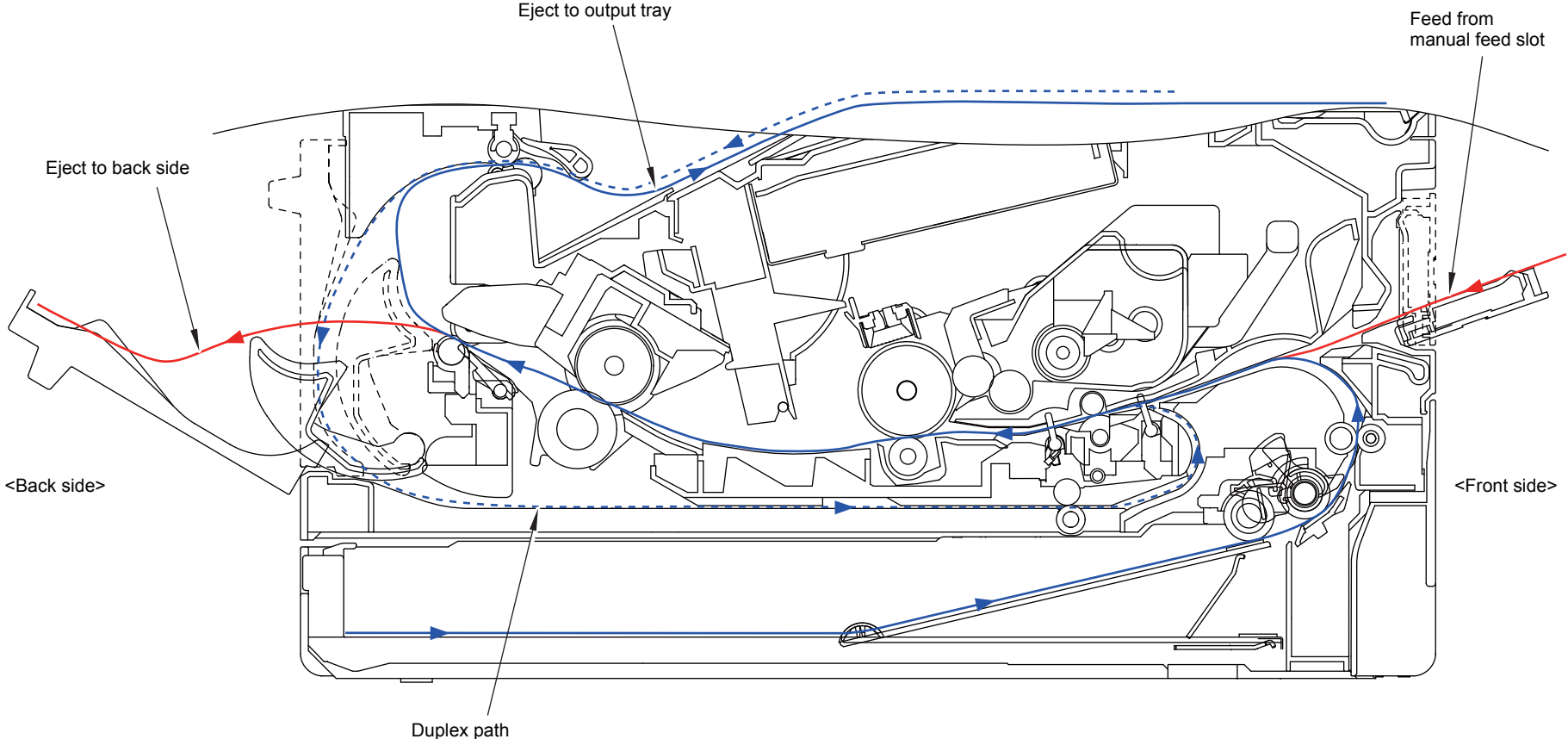


Fig. 2-5

■ MP models

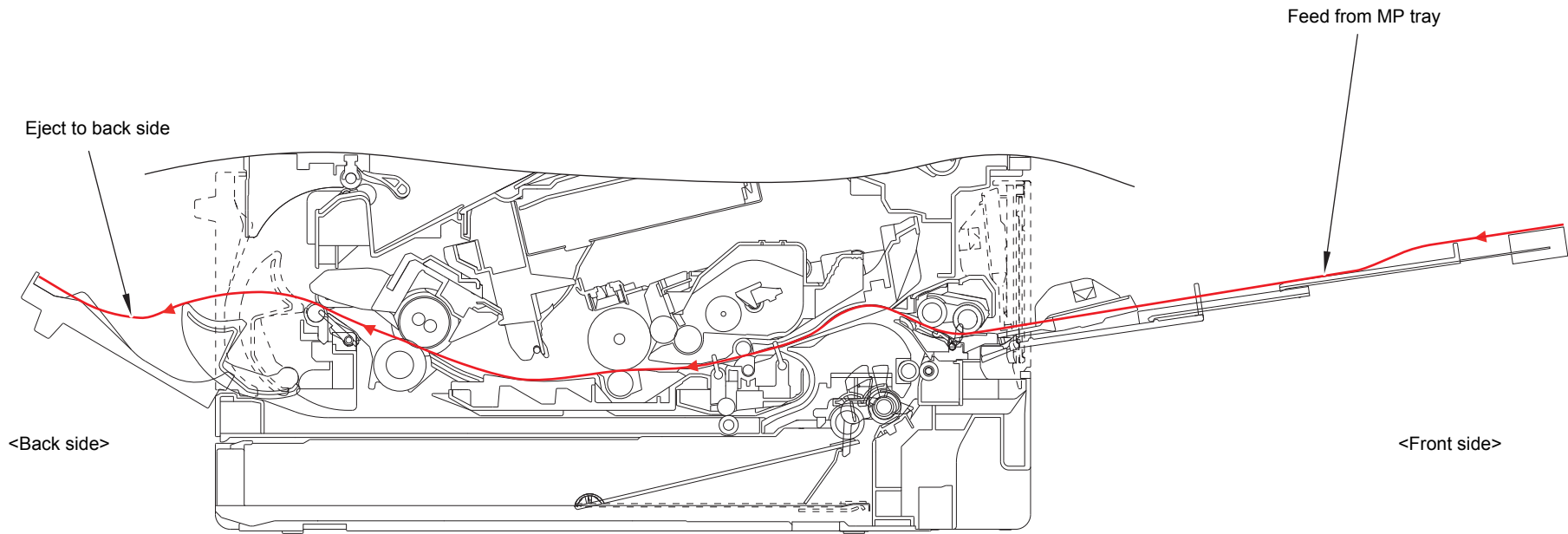


Fig. 2-6

## 2.2.2 Scanner part

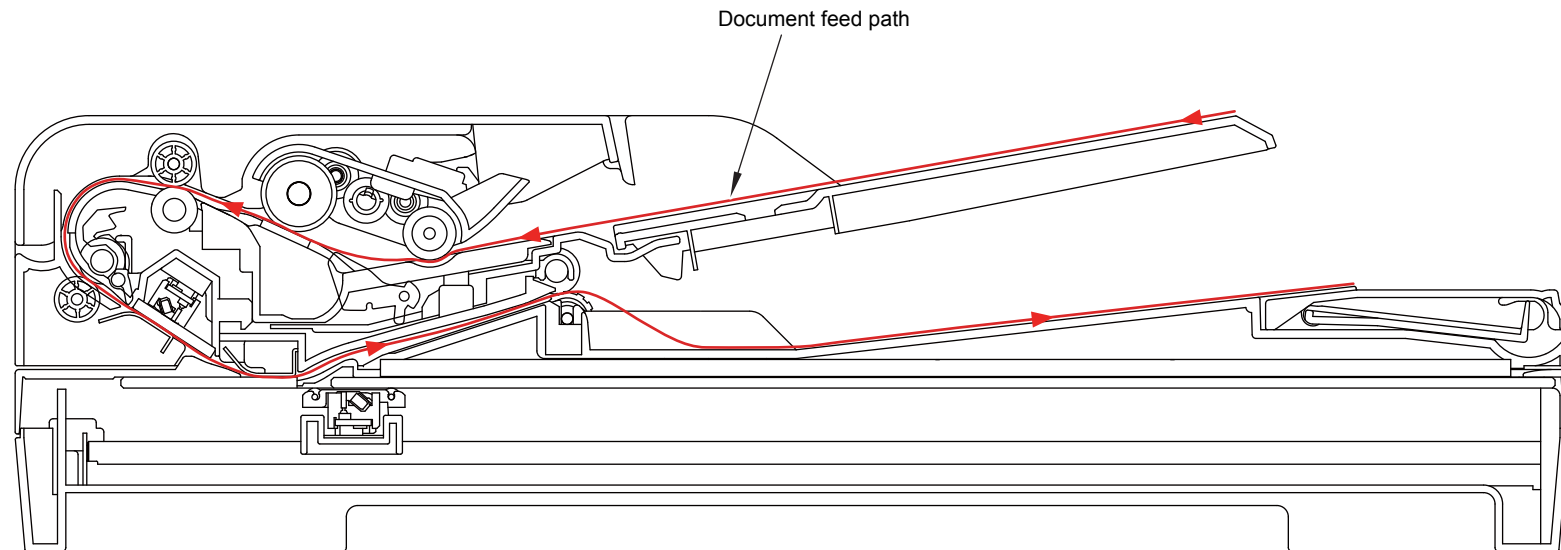


Fig. 2-7

## 2.3 Operation of Each Part and Location of Parts

Part name	Operation
Paper pick up roller	Feeds the paper to the separation roller from the paper tray.
Separation roller, Separation pad	Separates paper fed from the paper tray into single sheets.
Paper feed actuator (Paper feed sensor)	Detects paper trays (open / closed). Detects paper jams in paper trays. Determines whether paper is fed from the paper tray.
Registration front actuator (Registration front sensor)	Detects the front edge of the paper to control the registration roller drive. Detects paper jams in the front section of the machine. Determines whether paper is fed from the paper tray.
Registration roller	Corrects the paper alignment when the paper makes contact with the stopped registration roller. After the correction, it rotates to feed the paper to the process.
Registration rear actuator (Registration rear sensor)	Detects paper pass and adjusts the writing start position for the paper. Detects paper jams in the front or center section of the machine. Detects the rear edge of the paper to determine the paper size.
Heat roller, Pressure roller	Fuses the toner transferred to paper by heat and pressure, and feeds paper to the eject roller 1.
Eject actuator (Eject sensor)	Detect whether or not paper is ejected from the fuser unit. In the case of the 2-sided printing, detect the rear edge of paper and adjust the timing of the eject roller 2 switching. Detects paper jam in the rear section of the machine. Detects open fuser cover.
Eject roller 1	Feeds the paper ejected from the fuser unit to eject roller 2.
Eject roller 2	Eject the paper to the face-down output tray. In the case of the 2-sided printing, after the front of the sheet is printed and the paper is fed up to a certain point, eject roller 2 rotates conversely, and the paper is fed to the duplex tray.
Duplex paper feed roller	Feeds the paper passing through the duplex tray to the registration roller.
Back cover/duplex tray sensor	Detects open / closed back cover or the duplex tray is set.
Front cover sensor	Detects open / closed front cover.
Paper empty actuator	Detects the paper in the paper tray 1. Detects paper jams in the paper tray 1.
MP paper pick-up roller	Feeds paper from the MP tray to the MP separation roller.
MP separation roller, MP separation pad	Separates the paper fed from the MP tray into single sheets.
MP paper empty actuator (MP paper empty sensor)	Detects the paper in the MP tray. Detects paper jams in the MP tray.
Document pick-up roller	Feeds document from the document tray.
Document separate roller, ADF separation pad	Separates the document fed from the document tray into single sheets.
Document detection actuator (Document detection sensor)	Detects whether a document is set in the ADF.
Document scanning position actuator (Document scanning position sensor)	Detects the document scanning start position. Detects a document jam in the ADF.
Document eject roller	Feeds the document to the output tray.
ADF cover sensor	Detects open / closed ADF cover.



Part name	Operation
New toner sensor	When exchange to the new toner cartridge, detects the kinds of toner and add 1 to the reset of the developing bias and to the exchange count.
Toner sensor	Detects the toner cartridge is set.
External temperature/humidity sensor	Detects external temperature and humidity around the machine.
Pickup clutch	Drives the pick up roller at the timing of paper feeding.
Registration clutch	Controls the activation of the registration roller for the paper alignment adjustment.
MP solenoid	Presses the MP paper pick-up roller against the paper when feeding from the MP tray.

■ Location of sensors and clutches

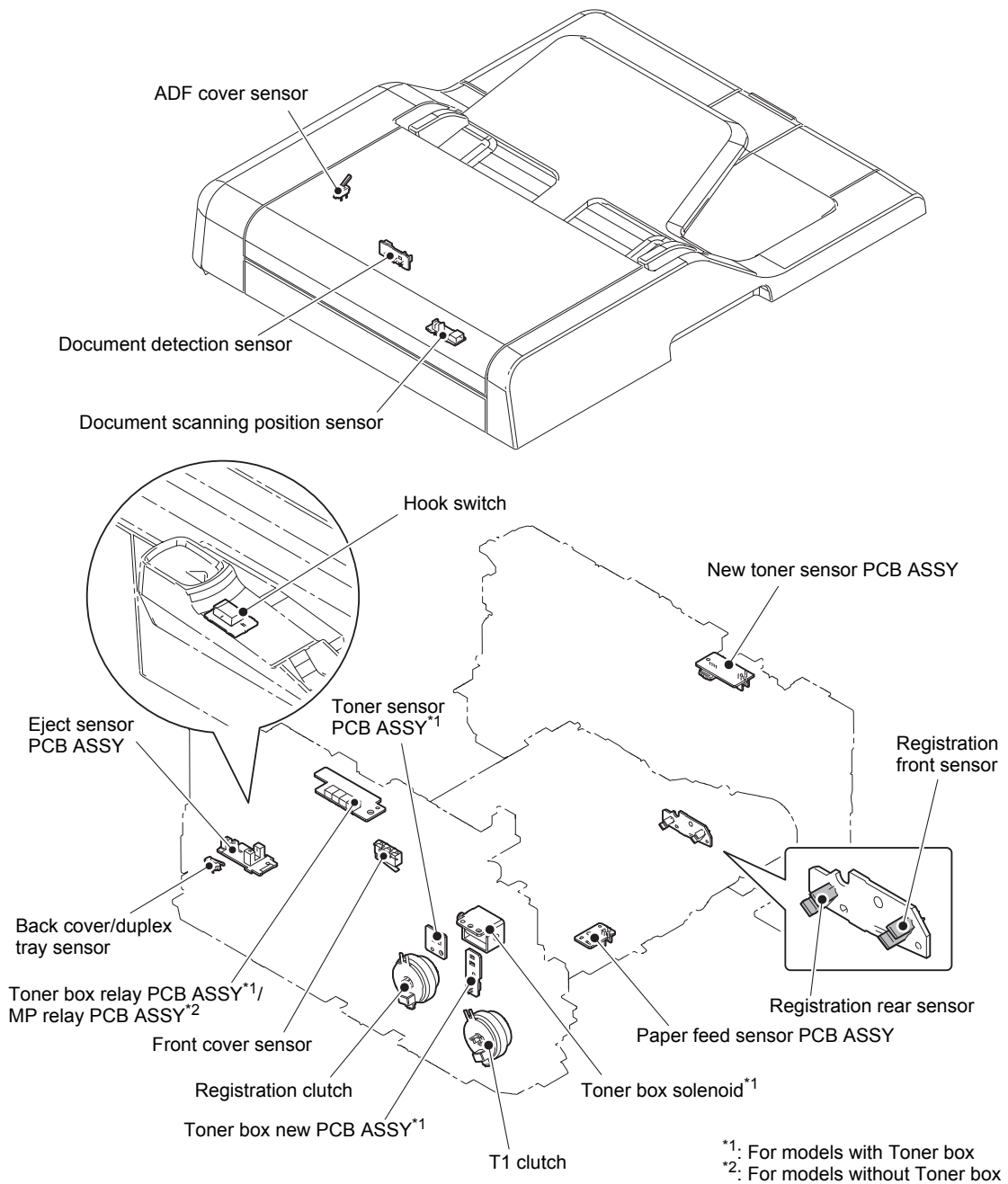


Fig. 2-8

## 2.4 Block Diagram

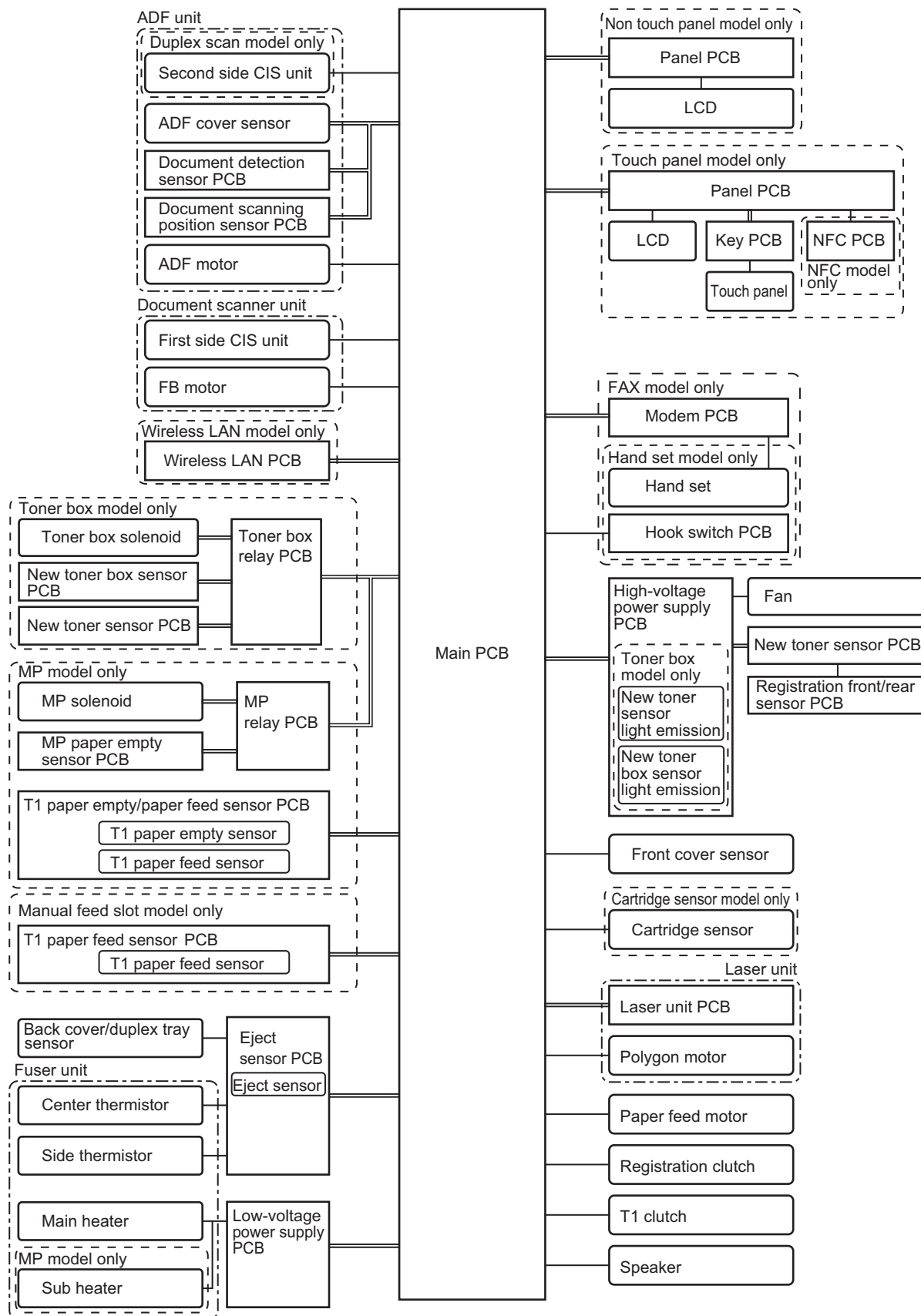


Fig. 2-9

# 2.5 Main Components

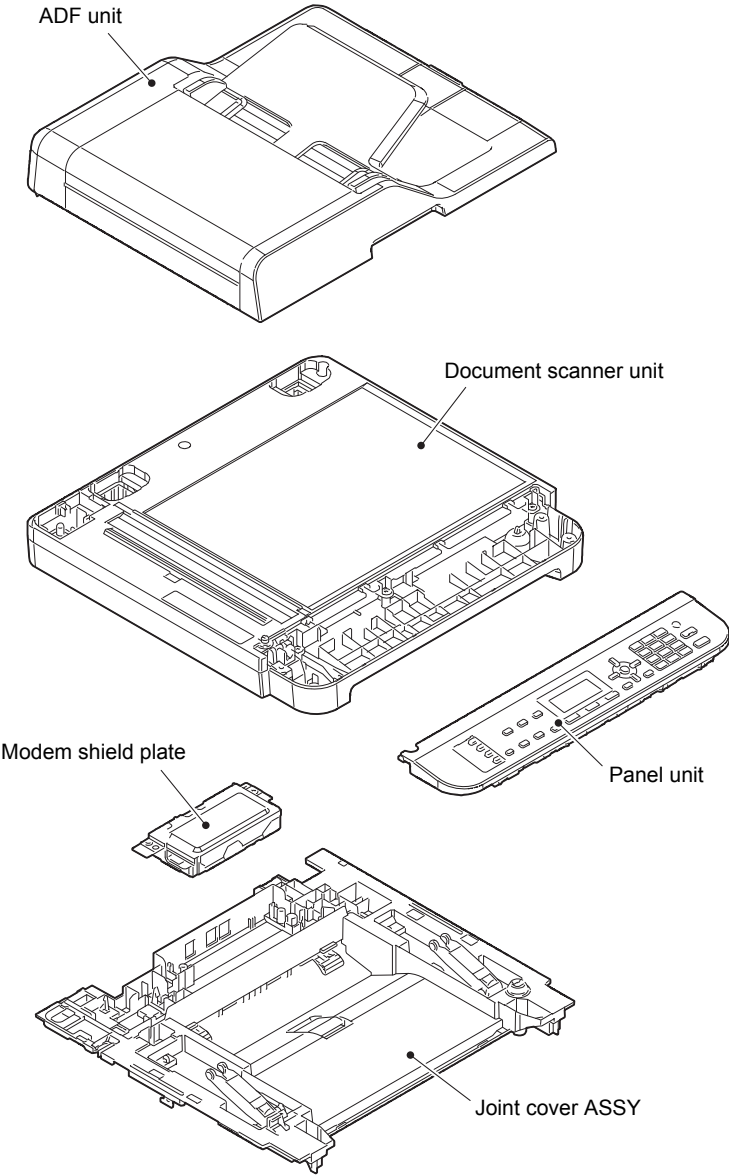
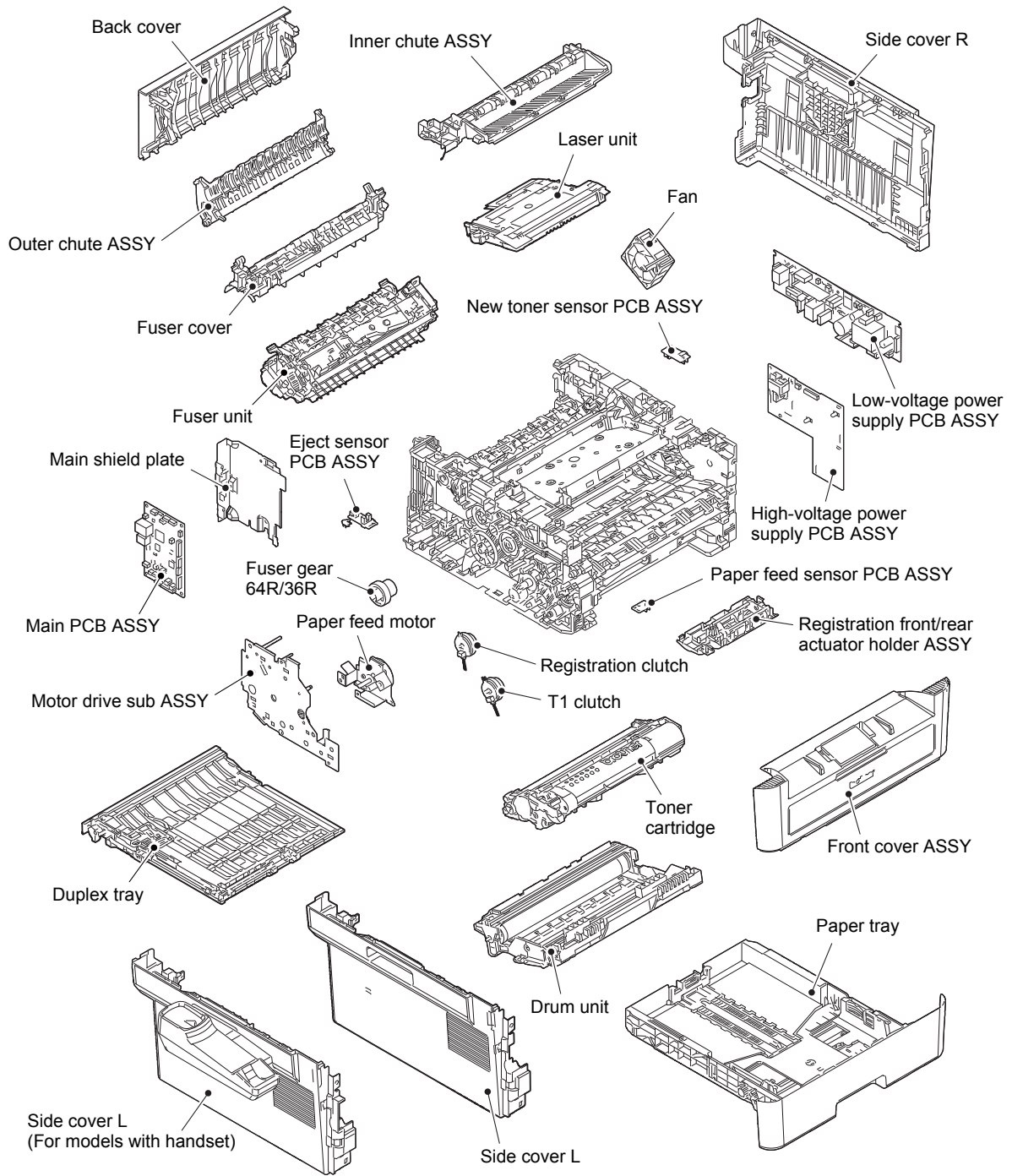


Fig. 2-10



**Fig. 2-11**

## 3. ERROR INDICATIONS

This machine includes a self-diagnosis function. If the machine does not work normally it judges that an error has occurred, and indicates the corresponding error message on the LCD, which in turn helps the service personnel to quickly find out the problem.

### 3.1 Error Codes

The shaded errors hardly occur under normal use. They may be caused by noise around the installation site, variation in power supply voltage, or software failure.

Error Codes	Description	Refer to:	Error Codes	Description	Refer to:
0101	---		050A	The hardware detected a temperature error through the center thermistor or the side thermistor of the fuser unit.	2-49
0102	ASIC error or motor driver error occurred.	2-47	050B	When the center thermistor of the fuser unit was lower than the idle temperature, the side thermistor detected a temperature higher than the specified temperature.	2-49
0201	Cannot detect the synchronized signal of the paper feed motor. The speed of the paper feed motor does not stabilize within the specified time.	2-47	050C	When the center thermistor of the fuser unit was higher than the idle temperature, the side thermistor detected a temperature lower than the specified temperature.	2-49
0202	---		050D	---	
0203	---				
0300	Cannot detect the lock signal of the polygon motor for the laser unit. (second time)	2-47	050F	---	
0305	Cannot detect the lock signal of the polygon motor for the laser unit. (first time)	2-47	0800	---	
0401	BD sensor failure (second time)	2-48	0900	Detected irregular power supply for more than 100 times.	2-50
0402	---		0A01	---	
0405	BD sensor failure (first time)	2-48	0A02	Detected a fan failure.	2-50
0501	The center thermistor of the fuser unit has not reached the specified temperature within the specified time.	2-49	0A03	---	
0502	The center thermistor of the fuser unit has not reached the specified temperature within the specified time after it was heated normally to the certain level.	2-49	0B01	An error occurred in the high-voltage power supply PCB ASSY while operating.	2-51
0503	The center thermistor of the fuser unit detected a temperature higher than the specified value.	2-49	0B02	An error occurred in the high-voltage power supply PCB ASSY when the machine was in the ready state.	2-51
0504	After the heat unit was heated normally, the center thermistor of the fuser unit detected a temperature lower than the specified value.	2-49	0C00	---	
0505	The center thermistor of the fuser unit detected a temperature rise greater than the specified value within the specified time.	2-49	0D01	---	
0506	The center thermistor of the fuser unit detected a temperature fall greater than the specified value within the specified time.	2-49	0D02	---	
0508	Temperature of the end part didn't rise by 1 °C when the fuser unit heater was turned ON.	2-49	0D03	---	

Error Codes	Description	Refer to:	Error Codes	Description	Refer to:
0D04	---		2500	Toner cartridge could not communicate with the cartridge sensor.	2-51
0E00	---		2501	---	
1003	---		2502	---	
1004	---		2503	---	
1100	---		2601	---	
1200	---		2602	---	
1300	---		2603	---	
1400	---		2604	---	
1500	---		2605	---	
1701	---		2701	---	
1801	---		2702	---	
1802	---		2703	---	
1803	---		2801	---	
1808	---		2802	---	
1901	---		2803	---	
1A01	---		2804	---	
1B01	---		2805	---	
1C00	---		2806	---	
1D01	---		2901	---	
1D02	---		2902	---	
1D03	---		2903	---	
1D04	---		2904	---	
1E01	---		2905	---	
1E02	---		2906	---	
1F00	---		2A01	---	
1F02	---		2A02	---	
2000	---		2A03	---	
2001	---		2B01	---	
2002	---		2B02	---	
2003	---		2C01	---	
2100	---		2C02	---	
2101	---		2D01	---	
2102	---		2E00	Could not communicate with the cartridge sensor on the machine side.	2-51
2103	---		2E01	---	
2200	Cartridge sensor detected that the incompatible toner cartridge was installed.	2-51	2E03	---	
2201	---		2F01	---	
2202	---		2F03	---	
2203	---		3001	---	
2400	Toner cartridge is not recognized by the cartridge sensor.	2-51	3002	---	
2401	---		3003	---	
2402	---		3102	---	
2403	---		3202	---	

Error Codes	Description	Refer to:	Error Codes	Description	Refer to:
3301	---		4A00	---	
3302	---		4B01	Dot counter of the toner cartridge or develop roller counter reaches the upper limit soon.	2-52
3401	---		4B02	---	
3402	---		4B03	---	
3501	---		4B04	---	
3601	---		4B06	The amount of toner supplied of the toner box reaches the upper limit soon.	2-52
3701	---		4C01	Dot count or develop roller counter of the toner cartridge in models without toner box has reached the upper limit in the toner stop mode.	2-52
3702	---		4C02	---	
3703	---		4C03	---	
3801	---		4C04	---	
3802	---		4C05	---	
3900	---		4C06	The amount of toner supplied of the toner box has reached the upper limit.	2-52
3A00	A communication error occurred between the controller and engine in main PCB.	2-51	4D01	Dot count or develop roller counter of the toner cartridge in models without toner box is reaching the upper limit in the continuous printing mode.	2-52
4000	Number of the drum unit rotations reaches the upper limit soon.	2-52	4E01	Toner cartridge in models without toner box has reached the upper limit in the continuous printing mode.	2-52
4001	---		4F01	The new toner sensor of the toner cartridge could not detect a new cartridge properly.	2-53
4002	---		4F02	---	
4003	---		4F03	---	
4004	---		4F04	---	
4200	Number of the drum unit rotations has reached the upper limit.	2-52	4F05	New process sensor could not detect the new drum unit correctly.	2-53
4201	---		5001	---	
4202	---		5002	---	
4203	---		5003	---	
4204	---		5004	---	
4209	---		5005	---	
4300	---		5006	---	
4400	---		5100	---	
4500	---		5200	---	
4600	---		5301	---	
4700	---		5302	---	
4800	---		5401	---	
4900	---		5402	---	

Error Codes	Description	Refer to:	Error Codes	Description	Refer to:
5406	---		6300	---	
5502	---		6400	---	
5602	---		6602	---	
5702	---		6701	---	
5801	---		6801	The side thermistor detected a temperature higher than the specified value.	2-57
5802	---		6802	---	
5902	---		6901	Some fuser unit errors occurred at power-ON or upon recovery from sleep mode.	2-57
5A02	---		6902	After the error was detected at the fuser unit, power was turned ON again and the error is being checked. (If power is turned OFF and ON after error code 6901 occurred, this code is displayed for about 15 minutes.)	2-57
5B02	---		6A00	Electric discharge that may be caused by dirt on the corona wire of the drum unit was detected.	2-58
5C02	---		6B01	---	
5D02	---		6B02	---	
5E00	New toner box sensor could not detect the new toner box correctly.	2-53	6B03	---	
6001	The front cover sensor detected that the front cover was open.	2-54	6B04	---	
6002	---		6B0A	---	
6003	---		6C01	---	
6004	The eject sensor detected that the fuser cover was open.	2-54	6C02	---	
6007	---		6C03	---	
6101	The new toner sensor detected that no toner cartridge was set.	2-55	6C04	---	
6102	---		6D00	---	
6103	---		6E00	---	
6104	---		6F00	Detected that supply power is unstable. (less than 100 times)	2-58
6106	The new toner box sensor detected that no toner box was set.	2-55	7000	After the registration rear sensor detects paper pass, the eject sensor does not detect paper pass.	2-58
6200	Detected that the drum unit was not set by detecting the electrodes current.	2-55	7001	---	
6201	---		7002	---	
6202	---		7003	---	
6203	---		7004	---	
6204	---		7100	After the registration rear sensor detects the end of paper pass and the specified period of time has passed, the eject sensor continues to detect paper pass.	2-59
6208	---		7101	---	
6209	---		7102	---	
620A	---		7103	---	



Error Codes	Description	Refer to:	Error Codes	Description	Refer to:
7104	---		8100	---	
7105	---		8401	---	
7106	---		8402	---	
7200	When the paper is fed from the MP tray, after the MP paper empty sensor detects paper pass, the registration rear sensor does not detect paper pass after a set period of time.	2-59	8403	---	
7300	---		8501	---	
7301	---		8502	---	
7302	When printing from the paper tray, the registration front sensor does not detect paper pass within the specified time after the T1 paper feed sensor detected paper pass.	2-60	8503	---	
7400	---		8504	---	
7401	---		8505	---	
7402	---		8506	---	
7500	---		8507	---	
7501	---		8508	---	
7502	---		8601	---	
7601	---		8602	---	
7602	---		8603	---	
7701	---		8604	---	
7702	---		8701	---	
7800	After the first side is printed in 2-sided printing mode, the registration front sensor does not detect paper pass after a set period of time.	2-60	8702	---	
7801	---		8703	---	
7802	---		8708	---	
7803	---		8709	---	
7804	---		870A	---	
7805	---		870B	---	
7900	---		870C	---	
7A01	---		870D	---	
7A02	---		870E	---	
7B01	---		870F	---	
7B02	---		8801	---	
7B03	---		8802	---	
7B04	---		8808	---	
7B05	---		8809	---	
7C00	---		880A	---	
7D00	---		8901	---	
7E00	---		8902	---	
7F00	---		8903	The back cover sensor detected the open state when 2-sided printing is started (before the registration of printing in the engine).	2-61
8000	---		8904	The back cover sensor detected the open state during 2-sided printing (after the registration of printing in the engine).	2-61

Error Codes	Description	Refer to:	Error Codes	Description	Refer to:
8A01	The registration rear sensor detected that the paper fed was smaller or larger than the specified size in duplex printing mode.	2-61	9203	---	
8A02	---		9204	---	
8B01	---		9205	---	
8C00	There is no paper set in the manual feed slot on the manual feed slot printing.	2-61	9206	---	
8D01	---		9301	When paper was fed from the MP tray, the MP paper empty sensor detected that no paper was in the MP tray.	2-63
8D02	---		9302	When paper was fed from the paper tray, the T1 paper empty sensor or T1 paper feed sensor detected that no paper was in the paper tray.	2-63
8E01	Paper size is not set as A4/Letter/Legal/Folio when receiving fax or printing a list/report.	2-62	9303	---	
8E02	Detected that the size of paper set in the paper tray was over 10 mm shorter than paper size set in the machine during faxing or printing a list or report.	2-62	9304	---	
8F01	---		9305	---	
8F02	---		9306	---	
8F03	---		9309	Detected that there was no paper set in all trays when TrayAuto was selected for printing.	2-64
9001	The size of paper loaded in the MP tray and the one specified from the driver are not same when paper is fed from the MP tray.	2-62	930A	Paper ran out during Fax / List continuous printing.	
9002	The size of paper loaded in the paper tray and the one specified from the driver are not same when paper is fed from the paper tray.	2-62	9501	---	
9003	---		9502	---	
9004	---		9503	---	
9005	---		9504	---	
9006	---		9505	---	
9102	---		9601	---	
9103	---		9608	---	
9104	---		9701	For 2-sided printing, paper size setting of the printer driver that was not supported by 2-sided printing was selected.	2-64
9105	---		9702	For printing by feeding paper from the paper tray, the size of paper specified from the driver set the size which was not supported by the paper tray.	2-64
9200	---		9703	---	
9201	When printing from the MP tray, paper type setting in the machine does not match the setting in the driver.	2-62	9704	---	
9202	When printing from the paper tray, paper type setting in the machine does not match the setting in the driver.	2-62	9705	---	

Error Codes	Description	Refer to:	Error Codes	Description	Refer to:
9706	---		9D04	---	
9801	---		9D05	---	
9802	---		A000	Image processing was not completed correctly because the number of pixels required for image processing is insufficient in the scanned second side data.	2-65
9803	---		A200	The document scanning position sensor detected that the document length was 90 cm or more during the one-side scanning.	2-65
9804	---		A300	The document scanning position sensor has not detected the document passing even after the document has been fed for the specified time.	2-65
9901	---		A400	The ADF cover sensor detected that the ADF cover was open.	2-66
9902	---		A500	When scanning the fax, white or black correction data for the first side CIS unit was not within the correct range (first time).	2-66
9903	---		A600	When scanning the fax, white or black correction data for the first side CIS unit was not within the correct range (second time).	2-66
9A01	---		A700	Color parameter in the ROM does not match the first side or second side CIS.	2-67
9A02	---		A800	---	
9A03	---		A900	A scanning error occurred while processing the scanned image.	2-67
9B01	---		AA00	---	
9B02	---		AB00	---	
9B03	---		AC00	When scanning the fax, white or black correction data for the second side CIS was not within the correct range (first time).	2-67
9B04	---		AD00	Image processing cannot be completed correctly because the number of pixels required for image processing is insufficient in the scanned first side data.	2-67
9B05	---		AE00	---	
9B06	---		AF00	Home position is still being detected even after the first side CIS unit was moved.	2-68
9C01	---		B000	Detected that the first side CIS flat cable or second side CIS flat cable was not inserted correctly when function code 55 was executed.	2-68
9C02	---		B700	---	
9C03	---		B800	---	
9C06	---		B900	---	
9C07	---		BB00	A white level not within the standard was scanned when function code 55 was executed.	2-69
9D02	---		BC00	When scanning the fax, white or black correction data for the second side CIS was not within the correct range (second time).	2-69
9D03	---		BD00	A black level not within the standard was scanned when function code 55 was executed.	2-69

Error Codes	Description	Refer to:	Error Codes	Description	Refer to:
BF00	The document scanning position sensor detected that the document length was 400 mm or longer and could not be fed to ADF (double-side restoration).	2-70	ED00	---	
C001	---		EE00	---	
C002	---		F900	The spec code was not entered correctly.	2-72
C003	---		FA01	---	
C004	---		FA02	---	
C100	---		FA03	---	
C700	The memory is insufficient to expand the data of PC-Print.	2-70	FB01	---	
C800	The memory used to store secure print data exceeded the memory size for secure print data.	2-70	FB02	---	
C900	---		FB03	---	
CA00	---		FB04	---	
D100	An error occurred while initializing the modem.	2-70	FB05	---	
D200	Detected that the modem PCB is not connected.	2-70	FB06	---	
D800	An error occurred while initializing the touch panel.	2-71	FB07	---	
D900	---		FB08	---	
DA00	---		FB09	---	
DB00	---		FB0A	---	
E000	An error occurred in the ROM check sum.	2-71	FB0B	---	
E001	---		FB0C	---	
E002	---		FB0D	---	
E100	Program error	2-71	FB0E	---	
E400	---		FB0F	---	
E500	An error occurred during access to the DRAM in the main PCB ASSY.	2-71	FC01	---	
E600	Write error in the EEPROM of the main PCB ASSY	2-71	FC02	---	
E701	System error in the flash ROM	2-71	FC03	---	
E702	Read error in the flash ROM	2-71	FC04	---	
E900	An error occurred while initializing the NFC.	2-72	FC05	---	
EC00	---				

## 3.2 Error Message

The error messages displayed on the LCD of the machine and their description are shown in the table below.

### 3.2.1 LCD models

Error message		Description	Error codes	Refer to:
Initial display	Scroll			
<b>Cannot Detect</b>	<b>Put the Drum Unit back in.</b>	New process sensor could not detect the new drum unit correctly.	4F05	2-53
	<b>Put the Toner Cartridge back in.</b>	Toner cartridge is not recognized by the cartridge sensor.	2400	2-51
<b>Cartridge Error</b>	<b>Put the Toner Cartridge back in.</b>	The new toner sensor of the toner cartridge could not detect a new cartridge properly.	4F01	2-53
		New toner box sensor could not detect the new toner box correctly.	5E00	2-53
<b>Connect the line cord to LINE socket on the machine, and then set line type from Initial Setup in menu.</b>	<b>▲ Cancel</b>	Completed auto-detect as line cord remained connected to the external terminal.	---	4.13.3
<b>Connected the line cord?</b>	<b>▲ Done ▼ Later</b>	Auto-detect ended without detecting the line voltage.	---	4.13.3
<b>Cooling Down</b>	<b>Wait for a while</b>	The side thermistor detected a temperature higher than the specified value.	6801	2-57
<b>Cover is Open</b>	<b>Close the ADF Cover.</b>	The ADF cover sensor detected that the ADF cover was open.	A400	2-66
	<b>Close the Front Cover.</b>	The front cover sensor detected that the front cover was open.	6001	2-54
	<b>Close the Fuser Cover which can be found behind the Back Cover of the machine.</b>	The eject sensor detected that the fuser cover was open.	6004	2-54

Error message		Description	Error codes	Refer to:
Initial display	Scroll			
<b>Document Jam</b>	<b>Clear the scanner jam, then press the Stop Key.</b>	The document scanning position sensor detected that the document length was 90 cm or more during the one-side scanning.	A200	2-65
		The document scanning position sensor has not detected the document passing even after the document has been fed for the specified time.	A300	2-65
<b>Drum !</b>	<b>Slide the Green tab on Drum Unit.</b>	Electric discharge that may be caused by dirt on the corona wire of the drum unit was detected.	6A00	2-58
<b>Drum End Soon</b>	-	Number of the drum unit rotations reaches the upper limit soon.	4000	2-52
<b>Ignore Data</b>	-	Detected undecodable data during printing. Received undecodable PS data.	---	4.14.1
<b>Jam 2-sided</b>	<b>Pull out the 2-sided Tray at the back of the machine and remove the jammed paper.</b>	After the first side is printed in 2-sided printing mode, the registration front sensor does not detect paper pass after a set period of time.	7800	2-60
<b>Jam Inside</b>	<b>Open the Front Cover, pull out the Drum Unit completely and remove the jammed paper.</b>	After the registration rear sensor detects paper pass, the eject sensor does not detect paper pass.	7000	2-58
<b>Jam MP Tray</b>	<b>Remove the jammed paper from MP Tray and press Go.</b>	When the paper is fed from the MP tray, after the MP paper empty sensor detects paper pass, the registration rear sensor does not detect paper pass after a set period of time.	7200	2-59
<b>Jam Rear</b>	<b>Open the Back Cover and remove the jammed paper, then press Go.</b>	After the registration rear sensor detects the end of paper pass and the specified period of time has passed, the eject sensor continues to detect paper pass.	7100	2-59
<b>Jam Tray 1</b>	<b>Remove the jammed paper from Tray 1.</b>	When printing from the paper tray, the registration front sensor does not detect paper pass within the specified time after the T1 paper feed sensor detected paper pass.	7302	2-60

Error message		Description	Error codes	Refer to:
Initial display	Scroll			
<b>Journal Full</b>	-	The number of the registered communication management reports reached 200.	---	4.14.5
<b>Machine Error</b>	-	Detected that the modem PCB is not connected.	D200	2-70
<b>Machine Error F9</b>	-	The spec code was not entered correctly.	F900	2-72
<b>Manual Feed</b>	<b>Load Paper.</b>	There is no paper set in the manual feed slot on the manual feed slot printing.	8C00	2-61
<b>Media Mismatch</b>	<b>Reload correct paper in MP Tray, then press Go.</b>	When printing from the MP tray, paper type setting in the machine does not match the setting in the driver.	9201	2-62
	<b>Reload correct paper in Tray 1, then press Go.</b>	When printing from the paper tray, paper type setting in the machine does not match the setting in the driver.	9202	2-62
<b>No Cartridge</b>	<b>Put the Toner Cartridge back in.</b>	Toner cartridge could not communicate with the cartridge sensor.	2500	2-51
<b>No Drum Unit</b>	<b>Open the Front Cover, then install the Drum Unit.</b>	Detected that the drum unit was not set by detecting the electrodes current.	6200	2-55
<b>No Paper</b>	<b>Reload paper in Tray.</b>	Detected that there was no paper set in all trays when TrayAuto was selected for printing.	9309	2-64
		Detected that there was no paper set in all trays when TrayAuto was selected for printing. (At Fax / List printing)	---	4.2.1
<b>No Paper MP</b>	<b>Reload paper in MP Tray.</b>	When paper was fed from the MP tray, the MP paper empty sensor detected that no paper was in the MP tray.	9301	2-63
		When paper was fed from the MP tray, the MP paper empty sensor detected that no paper was in the MP tray. (At Fax / List printing)	---	4.2.2

Error message		Description	Error codes	Refer to:
Initial display	Scroll			
<b>No Paper T1</b>	<b>Reload paper in Tray 1.</b>	When paper was fed from the paper tray, the T1 paper empty sensor or T1 paper feed sensor detected that no paper was in the paper tray.	9302	2-63
		When paper was fed from the paper tray, the T1 paper empty sensor or T1 paper feed sensor detected that no paper was in the paper tray. (At Fax / List printing)	---	4.2.1
	-	When paper was fed from the paper tray, the engine status detected that no paper was in the paper tray.	---	4.2.1
<b>No Toner</b>	<b>Open the Front Cover, then install Toner Cartridge.</b>	The new toner sensor detected that no toner cartridge was set.	6101	2-55
		The new toner box sensor detected that no toner box was set.	6106	2-55
<b>Out of Memory</b>	<b>Press Stop Key</b>	The memory is insufficient to expand the data of PC-Print.	C700	2-70
<b>Paper Low T1</b>	-	Detected that the paper is running out when the paper feed motor drive and T1 paper empty sensor turned ON.	---	4.14.3
<b>Print Data Full</b>	<b>Print Data is full. Press Cancel and delete the previously stored data.</b>	The memory used to store secure print data exceeded the memory size for secure print data.	C800	2-70
<b>Print Unable 01</b>	<b>Turn the power off and then back on again.</b>	ASIC error or motor driver error occurred.	0102	2-47
<b>Print Unable 02</b>	<b>Turn the power off and then back on again.</b>	Cannot detect the synchronized signal of the paper feed motor. The speed of the paper feed motor does not stabilize within the specified time.	0201	2-47
<b>Print Unable 03</b>	<b>Turn the power off and then back on again.</b>	Cannot detect the lock signal of the polygon motor for the laser unit. (second time)	0300	2-47
<b>Print Unable 04</b>	<b>Turn the power off and then back on again.</b>	BD sensor failure (second time)	0401	2-48



Error message		Description	Error codes	Refer to:
Initial display	Scroll			
<b>Print Unable 05</b>	<b>Turn the power off and then back on again.</b>	Detected the fuser unit temperature error.	0501	2-49
			0502	2-49
			0503	2-49
			0504	2-49
			0505	2-49
			0506	2-49
			0508	2-49
			050A	2-49
			050B	2-49
050C	2-49			
<b>Print Unable 09</b>	<b>Turn the power off and then back on again.</b>	Detected irregular power supply for more than 100 times.	0900	2-50
<b>Print Unable 0A</b>	<b>Turn the power off and then back on again.</b>	Detected a fan failure.	0A02	2-50
<b>Print Unable 0B</b>	<b>Turn the power off and then back on again.</b>	An error occurred in the high-voltage power supply PCB ASSY while operating.	0B01	2-51
		An error occurred in the high-voltage power supply PCB ASSY when the machine was in the ready state.	0B02	2-51
<b>Print Unable 2E</b>	<b>Turn the power off and then back on again.</b>	Could not communicate with the cartridge sensor on the machine side.	2E00	2-51
<b>Print Unable 3A</b>	<b>Turn the power off and then back on again.</b>	A communication error occurred between the controller and engine in main PCB.	3A00	2-51
<b>Print Unable A7</b>	<b>Turn the power off and then back on again.</b>	Color parameter in the ROM does not match the first side or second side CIS.	A700	2-67
<b>Print Unable A9</b>	<b>Turn the power off and then back on again.</b>	A scanning error occurred while processing the scanned image.	A900	2-67
<b>Print Unable D1</b>	<b>Turn the power off and then back on again.</b>	An error occurred while initializing the modem.	D100	2-70

Error message		Description	Error codes	Refer to:
Initial display	Scroll			
<b>Print Unable E0</b>	<b>Turn the power off and then back on again.</b>	An error occurred in the ROM check sum.	E000	2-71
<b>Print Unable E1</b>	<b>Turn the power off and then back on again.</b>	Program error	E100	2-71
<b>Print Unable E5</b>	<b>Turn the power off and then back on again.</b>	An error occurred during access to the DRAM in the main PCB ASSY.	E500	2-71
<b>Print Unable E6</b>	<b>Turn the power off and then back on again.</b>	Write error in the EEPROM of the main PCB ASSY	E600	2-71
<b>Print Unable E7</b>	<b>Turn the power off and then back on again.</b>	System error in the flash ROM	E701	2-71
		Read error in the flash ROM	E702	2-71
<b>Print Unable E9</b>	<b>Turn the power off and then back on again.</b>	An error occurred while initializing the NFC.	E900	2-72
<b>Print Unable ZC</b>	<b>Turn the power off and then back on again.</b>	Detected that supply power is unstable. (less than 100 times)	6F00	2-58
<b>Replace Drum</b>	-	Number of the drum unit rotations has reached the upper limit.	4200	2-52
<b>Replace Toner</b>	-	Dot count or develop roller counter of the toner cartridge in models without toner box is reaching the upper limit in the continuous printing mode.	4D01	2-52
	<b>Open the Front Cover, then install Toner Cartridge</b>	The amount of toner supplied of the toner box has reached the upper limit.	4C06	2-52
	<b>Open the Front Cover, replace Toner Cartridge.</b>	Dot count or develop roller counter of the toner cartridge in models without toner box has reached the upper limit in the toner stop mode.	4C01	2-52

Error message		Description	Error codes	Refer to:
Initial display	Scroll			
<b>Scan Unable</b>	<b>Document is too long for 2-sided scanning. Press Stop key.</b>	The document scanning position sensor detected that the document length was 400 mm or longer and could not be fed to ADF (double-side restoration).	BF00	2-70
	<b>Remove the original document. Turn the power off, then on again.</b>	Image processing was not completed correctly because the number of pixels required for image processing is insufficient in the scanned second side data.	A000	2-65
		Image processing cannot be completed correctly because the number of pixels required for image processing is insufficient in the scanned first side data.	AD00	2-67
<b>Scan Unable AF</b>	<b>Turn the power off and then back on again.</b>	Home position is still being detected even after the first side CIS unit was moved.	AF00	2-68
<b>Scanner Error</b>	-	A white level not within the standard was scanned when function code 55 was executed.	BB00	2-69
		A black level not within the standard was scanned when function code 55 was executed.	BD00	2-69
<b>SCANNER ERROR FB</b>	-	Detected that the first side CIS flat cable or second side CIS flat cable was not inserted correctly when function code 55 was executed.	B000	2-68
<b>SCANNER ERROR ADF</b>				
<b>Self-Diagnostic</b>	<b>Turn the power off, then on again. Leave the machine for 15 min.</b>	Some fuser unit errors occurred at power-ON or upon recovery from sleep mode.	6901	2-57
	<b>Will Automatically Restart within 15 minutes.</b>	After the error was detected at the fuser unit, power was turned ON again and the error is being checked. (If power is turned OFF and ON after error code 6901 occurred, this code is displayed for about 15 minutes.)	6902	2-57
<b>Size Error</b>	<b>Specify the correct paper size for Tray 1.</b>	For printing by feeding paper from the paper tray, the size of paper specified from the driver set the size which was not supported by the paper tray.	9702	2-64

Error message		Description	Error codes	Refer to:
Initial display	Scroll			
<b>Size Error DX</b>	<b>Press Stop Key. Specify the correct paper and load the same size paper as the Printer driver setting.</b>	For 2-sided printing, paper size setting of the printer driver that was not supported by 2-sided printing was selected.	9701	2-64
	<b>Specify the correct paper.</b>	The registration rear sensor detected that the paper fed was smaller or larger than the specified size in duplex printing mode.	8A01	2-61
<b>Sizemismatch</b>	<b>Fax received. Set correct paper size in menu.</b>	Paper size is not set as A4/ Letter/Legal/Folio when receiving fax or printing a list/ report.	8E01	2-62
	<b>Reload correct paper in the MP Tray, then press Start.</b>	The size of paper loaded in the MP tray and the one specified from the driver are not same when paper is fed from the MP tray.	9001	2-62
	<b>Reload correct paper in Tray1, then press Start.</b>	The size of paper loaded in the paper tray and the one specified from the driver are not same when paper is fed from the paper tray.	9002	2-62
	<b>Reload correct paper, then press Start.</b>	Detected that the size of paper set in the paper tray was over 10 mm shorter than paper size set in the machine during faxing or printing a list or report.	8E02	2-62
<b>Toner Ended</b>	<b>Open the Front Cover, replace Toner Cartridge.</b>	Toner cartridge in models without toner box has reached the upper limit in the continuous printing mode.	4E01	2-52
<b>Toner Low</b>	-	Dot counter of the toner cartridge or develop roller counter reaches the upper limit soon.	4B01	2-52
		The amount of toner supplied of the toner box reaches the upper limit soon.	4B06	2-52

Error message		Description	Error codes	Refer to:
Initial display	Scroll			
<b>Wrong Paper Size</b>	<b>Reload correct paper in the MP Tray or press Start.</b>	MP tray ran out of paper and the paper tray alternatively chosen has paper in different size when the paper used for copy was from the MP tray and the choice of tray was set to Auto.	---	4.14.1
	<b>Reload correct paper in Tray 1 or press Start.</b>	Paper tray ran out of paper and the MP tray alternatively chosen has paper in different size when the paper used for copy was from the paper tray and the choice of tray was set to Auto.	---	4.14.1
<b>Wrong Toner</b>	<b>Open the Front Cover, then install Toner Cartridge</b>	Cartridge sensor detected that the incompatible toner cartridge was installed.	2200	2-51
<b>2-sided Disabled</b>	<b>Close the Back Cover of the machine.</b>	The back cover sensor detected the open state when 2-sided printing is started (before the registration of printing in the engine).	8903	2-61
		The back cover sensor detected the open state during 2-sided printing (after the registration of printing in the engine).	8904	2-61

### 3.2.2 Touch panel models

Error message		Description	Error codes	Refer to:
Upper line	Lower line			
<b>Cannot Detect</b>	<b>Put the Drum Unit back in.</b>	New process sensor could not detect the new drum unit correctly.	4F05	2-53
	<b>Put the Toner Cartridge back in.</b>	Toner cartridge is not recognized by the cartridge sensor.	2400	2-51
<b>Cartridge Error</b>	<b>Put the Toner Cartridge back in.</b>	The new toner sensor of the toner cartridge could not detect a new cartridge properly.	4F01	2-53
		New toner box sensor could not detect the new toner box correctly.	5E00	2-53
<b>Cooling Down</b>	<b>Wait for a while</b>	The side thermistor detected a temperature higher than the specified value.	6801	2-57
<b>Cover is Open</b>	-	The front cover sensor detected that the front cover was open.	6001	2-54
		The eject sensor detected that the fuser cover was open.	6004	2-54
		The ADF cover sensor detected that the ADF cover was open.	A400	2-66
<b>Document Jam</b>	-	The document scanning position sensor has not detected the document passing even after the document has been fed for the specified time.	A300	2-65
<b>Document Jam/too Long</b>	<b>Remove jammed paper.</b>	The document scanning position sensor detected that the document length was 90 cm or more during the one-side scanning.	A200	2-65
<b>Drum !</b>	-	Electric discharge that may be caused by dirt on the corona wire of the drum unit was detected.	6A00	2-58
<b>Failed to Detect the Line Type</b>	<b>Connect the line cord to LINE socket on the machine, and then set line type from menu.</b>	Completed auto-detect as line cord remained connected to the external terminal.	---	4.13.3
<b>Ignore Data</b>	<b>Press Stop[x].</b>	Received undecodable PS data.	---	4.14.1
<b>Jam 2-sided</b>	-	After the first side is printed in 2-sided printing mode, the registration front sensor does not detect paper pass after a set period of time.	7800	2-60

Error message		Description	Error codes	Refer to:
Upper line	Lower line			
<b>Jam Inside</b>	-	After the registration rear sensor detects paper pass, the eject sensor does not detect paper pass.	7000	2-58
<b>Jam MP Tray</b>	-	When the paper is fed from the MP tray, after the MP paper empty sensor detects paper pass, the registration rear sensor does not detect paper pass after a set period of time.	7200	2-59
<b>Jam Rear</b>	-	After the registration rear sensor detects the end of paper pass and the specified period of time has passed, the eject sensor continues to detect paper pass.	7100	2-59
<b>Jam Tray</b>	-	When printing from the paper tray, the registration front sensor does not detect paper pass within the specified time after the T1 paper feed sensor detected paper pass.	7302	2-60
<b>Journal Full</b>	<b>Journal Full</b>	The number of the registered communication management reports reached 200.	---	4.14.5
<b>Machine Error</b>	-	Detected that the modem PCB is not connected.	D200	2-70
<b>Machine Error F9</b>	-	The spec code was not entered correctly.	F900	2-72
<b>Manual Feed</b>	-	There is no paper set in the manual feed slot on the manual feed slot printing.	8C00	2-61
<b>Media Type Mismatch</b>	<b>Reload correct paper in MP Tray, then press [Retry].</b>	When printing from the MP tray, paper type setting in the machine does not match the setting in the driver.	9201	2-62
	<b>Reload correct paper in Tray1, then press [Retry].</b>	When printing from the paper tray, paper type setting in the machine does not match the setting in the driver.	9202	2-62
<b>No Cartridge</b>	<b>Put the Toner Cartridge back in.</b>	Toner cartridge could not communicate with the cartridge sensor.	2500	2-51
<b>No Drum Unit</b>	<b>Open the Front Cover, then install the Drum Unit.</b>	Detected that the drum unit was not set by detecting the electrodes current.	6200	2-55

Error message		Description	Error codes	Refer to:
Upper line	Lower line			
<b>No Paper</b>	<b>Reload paper in Tray.</b>	Detected that there was no paper set in all trays when TrayAuto was selected for printing.	9309	2-64
	<b>Reload correct paper in Tray1, then press [Retry].</b>	Detected that there was no paper set in all trays when TrayAuto was selected for printing. (At Fax / List printing)	---	4.2.1
<b>No Paper MP</b>	-	When paper was fed from the MP tray, the MP paper empty sensor detected that no paper was in the MP tray.	9301	2-63
		When paper was fed from the MP tray, the MP paper empty sensor detected that no paper was in the MP tray. (At Fax / List printing)	---	4.2.2
<b>No Paper Tray1</b>	-	When paper was fed from the paper tray, the T1 paper empty sensor or T1 paper feed sensor detected that no paper was in the paper tray.	9302	2-63
		When paper was fed from the paper tray, the T1 paper empty sensor or T1 paper feed sensor detected that no paper was in the paper tray. (At Fax / List printing)	---	4.2.1
<b>No Toner</b>	<b>Open the Front Cover, then install Toner Cartridge.</b>	The new toner sensor detected that no toner cartridge was set.	6101	2-55
		The new toner box sensor detected that no toner box was set.	6106	2-55
<b>Out of Fax Memory</b>	<b>Delete unwanted fax data.</b>	The memory becomes near full when Fax preview is ON.	---	4.13.4
	<b>Print fax data from All settings &gt; Fax &gt; Print Fax</b>	The memory becomes near full when Fax preview is OFF and memory reception is ON.	---	4.13.4
<b>Out of Memory</b>	<b>Press Stop[x].</b>	The memory is insufficient to expand the data of PC-Print.	C700	2-70
<b>Phone line may not be connected</b>	<b>Check line connection. Refer to User's Guide.</b>	Auto-detect ended without detecting the line voltage.	---	4.13.3
<b>Paper loaded in MP Tray</b>	<b>Change the settings?</b>	No paper in the MP tray.	---	4.14.1



Error message		Description	Error codes	Refer to:
Upper line	Lower line			
<b>Print Data Full</b>	<b>Print Data is full. Press Stop[x] and delete the previously stored data.</b>	The memory used to store secure print data exceeded the memory size for secure print data.	C800	2-70
<b>Print Unable 01</b>	<b>Turn the power off and then back on again.</b>	ASIC error or motor driver error occurred.	0102	2-47
<b>Print Unable 02</b>	<b>Turn the power off and then back on again.</b>	Cannot detect the synchronized signal of the paper feed motor. The speed of the paper feed motor does not stabilize within the specified time.	0201	2-47
<b>Print Unable 03</b>	<b>Turn the power off and then back on again.</b>	Cannot detect the lock signal of the polygon motor for the laser unit. (second time)	0300	2-47
<b>Print Unable 04</b>	<b>Turn the power off and then back on again.</b>	BD sensor failure (second time)	0401	2-48
<b>Print Unable 05</b>	<b>Turn the power off and then back on again.</b>	Detected the fuser unit temperature error.	0501	2-49
			0502	2-49
			0503	2-49
			0504	2-49
			0505	2-49
			0506	2-49
			0508	2-49
			050A	2-49
			050B	2-49
050C	2-49			
<b>Print Unable 09</b>	<b>Turn the power off and then back on again.</b>	Detected irregular power supply for more than 100 times.	0900	2-50
<b>Print Unable 0A</b>	<b>Turn the power off and then back on again.</b>	Detected a fan failure.	0A02	2-50

Error message		Description	Error codes	Refer to:
Upper line	Lower line			
<b>Print Unable 0B</b>	<b>Turn the power off and then back on again.</b>	An error occurred in the high-voltage power supply PCB ASSY while operating.	0B01	2-51
		An error occurred in the high-voltage power supply PCB ASSY when the machine was in the ready state.	0B02	2-51
<b>Print Unable 2E</b>	<b>Turn the power off and then back on again.</b>	Could not communicate with the cartridge sensor on the machine side.	2E00	2-51
<b>Print Unable 3A</b>	<b>Turn the power off and then back on again.</b>	A communication error occurred between the controller and engine in main PCB.	3A00	2-51
<b>Print Unable A7</b>	<b>Turn the power off and then back on again.</b>	Color parameter in the ROM does not match the first side or second side CIS.	A700	2-67
<b>Print Unable D1</b>	<b>Turn the power off and then back on again.</b>	An error occurred while initializing the modem.	D100	2-70
<b>Print Unable E0</b>	<b>Turn the power off and then back on again.</b>	An error occurred in the ROM check sum.	E000	2-71
<b>Print Unable E1</b>	<b>Turn the power off and then back on again.</b>	Program error	E100	2-71
<b>Print Unable E5</b>	<b>Turn the power off and then back on again.</b>	An error occurred during access to the DRAM in the main PCB ASSY.	E500	2-71
<b>Print Unable E6</b>	<b>Turn the power off and then back on again.</b>	Write error in the EEPROM of the main PCB ASSY	E600	2-71
<b>Print Unable E7</b>	<b>Turn the power off and then back on again.</b>	System error in the flash ROM	E701	2-71
		Read error in the flash ROM	E702	2-71
<b>Print Unable E9</b>	<b>Turn the power off and then back on again.</b>	An error occurred while initializing the NFC.	E900	2-72
<b>Print Unable ZC</b>	<b>Turn the power off and then back on again.</b>	Detected that supply power is unstable. (less than 100 times)	6F00	2-58

Error message		Description	Error codes	Refer to:	
Upper line	Lower line				
<b>Replace Toner</b>	-	Dot count or develop roller counter of the toner cartridge in models without toner box has reached the upper limit in the toner stop mode.	4C01	2-52	
		The amount of toner supplied of the toner box has reached the upper limit.	4C06	2-52	
<b>Scan Unable</b>	<b>Document is too long for 2-sided scanning. Press Stop[x].</b>	The document scanning position sensor detected that the document length was 400 mm or longer and could not be fed to ADF (double-side restoration).	BF00	2-70	
		<b>Remove the original document. Turn the power off, then on again.</b>	Image processing was not completed correctly because the number of pixels required for image processing is insufficient in the scanned second side data.	A000	2-65
		Image processing cannot be completed correctly because the number of pixels required for image processing is insufficient in the scanned first side data.	AD00	2-67	
<b>Scan Unable A9</b>	<b>Turn the power off and then back on again.</b>	A scanning error occurred while processing the scanned image.	A900	2-67	
<b>Scan Unable AF</b>	<b>Turn the power off and then back on again.</b>	Home position is still being detected even after the first side CIS unit was moved.	AF00	2-68	
<b>Scanner Error BB</b>	-	A white level not within the standard was scanned when function code 55 was executed.	BB00	2-69	
		A black level not within the standard was scanned when function code 55 was executed.	BD00	2-69	
<b>Self-Diagnostic</b>	<b>Will automatically restart within 15 minutes.</b>	Some fuser unit errors occurred at power-ON or upon recovery from sleep mode.	6901	2-57	
	<b>Will Automatically Restart within 15 minutes.</b>	After the error was detected at the fuser unit, power was turned ON again and the error is being checked. (If power is turned OFF and ON after error code 6901 occurred, this code is displayed for about 15 minutes.)	6902	2-57	

Error message		Description	Error codes	Refer to:
Upper line	Lower line			
<b>Size Error</b>	<b>Specify the correct paper size for Tray 1.</b>	For printing by feeding paper from the paper tray, the size of paper specified from the driver set the size which was not supported by the paper tray.	9702	2-64
<b>Size Error 2-sided</b>	<b>Press [OK]. Specify the correct paper and load the same size paper as the Printer driver setting.</b>	For 2-sided printing, paper size setting of the printer driver that was not supported by 2-sided printing was selected.	9701	2-64
	<b>Press Stop[x]. Specify the correct paper and load the same size paper as Printer driver setting.</b>	The registration rear sensor detected that the paper fed was smaller or larger than the specified size in duplex printing mode.	8A01	2-61
<b>Sizemismatch</b>	<b>Reload correct paper.</b>	Paper size is not set as A4/ Letter/Legal/Folio when receiving fax or printing a list/ report.	8E01	2-62
		Detected that the size of paper set in the paper tray was over 10 mm shorter than paper size set in the machine during faxing or printing a list or report.	8E02	2-62
	<b>Reload correct paper in MP Tray, then press [Retry].</b>	The size of paper loaded in the MP tray and the one specified from the driver are not same when paper is fed from the MP tray.	9001	2-62
	<b>Reload correct paper in Tray1, then press [Retry].</b>	The size of paper loaded in the paper tray and the one specified from the driver are not same when paper is fed from the paper tray.	9002	2-62

Error message		Description	Error codes	Refer to:
Upper line	Lower line			
<b>Supplies</b>	<b>Drum End Soon</b>	Number of the drum unit rotations reaches the upper limit soon.	4000	2-52
	<b>Replace Drum</b>	Number of the drum unit rotations has reached the upper limit.	4200	2-52
	<b>Replace Toner</b>	Dot count or develop roller counter of the toner cartridge in models without toner box is reaching the upper limit in the continuous printing mode.	4D01	2-52
	<b>Toner Low</b>	Dot counter of the toner cartridge or develop roller counter reaches the upper limit soon.	4B01	2-52
		The amount of toner supplied of the toner box reaches the upper limit soon.	4B06	2-52
<b>Toner Ended</b>	<b>Open the Front Cover, replace Toner Cartridge.</b>	Toner cartridge in models without toner box has reached the upper limit in the continuous printing mode.	4E01	2-52
<b>Touchscreen Initialisation Failed</b>	<b>Remove any material which is on the touchscreen.</b>	An error occurred while initializing the touch panel.	D800	2-71
<b>Tray removed</b>	<b>Change the settings?</b>	Paper tray is open.	---	4.14.5
<b>Wrong Paper Size MP</b>	<b>Reload correct paper in MP Tray or press [Retry].</b>	MP tray ran out of paper and the paper tray alternatively chosen has paper in different size when the paper used for copy was from the MP tray and the choice of tray was set to Auto.	---	4.14.1
<b>Wrong Paper Size T1</b>	<b>Reload correct paper in Tray 1 or press [Retry].</b>	Paper tray ran out of paper and the MP tray alternatively chosen has paper in different size when the paper used for copy was from the paper tray and the choice of tray was set to Auto.	---	4.14.1
<b>Wrong Toner Cartridge</b>	<b>Open the Front Cover, then install the Toner Cartridge.</b>	Cartridge sensor detected that the incompatible toner cartridge was installed.	2200	2-51

Error message		Description	Error codes	Refer to:
Upper line	Lower line			
<b>2-sided Disabled</b>	-	The back cover sensor detected the open state when 2-sided printing is started (before the registration of printing in the engine).	8903	2-61
		The back cover sensor detected the open state during 2-sided printing (after the registration of printing in the engine).	8904	2-61

### 3.3 Communication Errors

Code 1	Code 2	Cause	Refer to:
10	07	No document set when calling.	4.11.1
10	08	Wrong fax number called.	4.13.1
11	01	No dial tone detected before dialing.	4.13.1
11	02	Busy tone detected before dialing.	4.13.1
11	03	2nd dial tone not detected.	4.13.1
11	05	No loop current detected.	4.13.1
11	06	Busy tone detected after dialing or receiving a call.	4.13.1
11	07	No response from the receiver in sending.	4.13.1
11	08	No response from the remote station in sending Session Initiation Protocol (SIP).	4.13.3
11	10	No tone detected after dialing.	4.13.1
11	11	No acknowledgement returned after Fax2 net command was sent.	4.13.1
13	12	Error signal received after Fax2 net command was sent.	4.13.1
16	09	No Cipher registration	4.13.1
17	01	Called using a dial number that cannot be used for the NGN line (33 digits or longer or non numeric characters).	4.13.2
17	07	No response from the caller in receiving.	4.13.2
1C	01	Detected that access to the NGN line was not authorized. (T38: 403 Forbidden)	4.13.3
1C	02	No file or folder (directory) found as a result of search via the NGN line. (T38: 404 Not Found)	4.13.3
1C	03	Remote station does not support the NGN line. (T38: 488 Not Acceptable Here)	4.13.3
1C	04	SIP (Session Initiation Protocol) connection not possible. (T38) USW NGN fax setting is OFF or calling attempted before acquisition of SIP information.	4.13.3
1C	05	Internal error detected in the communication network. (T38)	4.13.3
1C	06	SIP Server timeout (T38)	4.13.3
1C	08	An error other than 1C01,1C02,1C03,1C04,1C06,1D01,1D02 or 1D04 was detected.	4.13.3
1D	01	Detected that the NGN line was busy. (T38: 486 Busy)	4.13.3
1D	02	Detected that the NGN line was temporarily unavailable. (T38: 480 Temporarily Unavailable)	4.13.3
1D	04	Network cable not connected (Link Down detected) or not connected to the Network. (T38)	4.13.3

Code 1	Code 2	Cause	Refer to:
20	01	Unable to detect flag field.	4.13.3
20	02	Carrier was OFF for 200 ms or longer.	4.13.3
20	03	Abort detected ("1" in succession for 7 bits or more).	4.13.3
20	04	Overrun detected.	4.13.3
20	05	A frame received for 3 seconds or more.	4.13.3
20	06	CRC error in answerback.	4.13.3
20	07	Echo command received.	4.13.3
20	08	Invalid command received.	4.13.3
20	09	Command ignored in document setting or damping-out at turn-around transmission.	4.13.3
20	0A	T5 time-out error	4.13.3
20	0B	CRP received.	4.13.3
20	0C	EOR or NULL received.	4.13.3
20	0D	Corresponding command not received although the FIF command sending bit is ON.	4.13.3
20	0E	EOR command received.	4.13.3
20	13	Line disconnected without receiving DCN after receiving the last page. (After receiving EOP and sending CFR, received BYE before receiving DCN.) (T38)	4.13.3
32	01	Remote terminal only with V.29 capability in 2,400 or 4,800 bps transmission.	4.13.3
32	02	Remote terminal not ready for polling.	4.13.3
32	10	Remote terminal not equipped with password function or its password switch is OFF.	4.13.3
32	11	Remote terminal not equipped with or not ready for confidential mailbox function.	4.13.3
32	12	Remote terminal not equipped with or not ready for relay broadcasting function.	4.13.3
32	13	No confidential mail in the remote terminal.	4.13.3
32	14	Available memory space of the remote terminal is less than that required for reception of confidential mails or relay broad-casting instruction.	4.13.3
32	15	Remote terminal not equipped with Cipher receiving function.	4.13.3
32	16	Remote terminal not equipped with SEP function.	4.13.3
32	17	Remote terminal not equipped with SUB function.	4.13.3
32	18	Remote terminal not equipped with color function.	4.13.3
40	02	Illegal coding system requested.	4.13.3
40	03	Illegal recording width requested.	4.13.3



Code 1	Code 2	Cause	Refer to:
40	05	ECM requested although not allowed.	4.13.3
40	06	Polled while not ready.	4.13.3
40	07	No document to be sent when polled.	4.11.1
40	10	Nation code or manufacturer code not correct.	4.13.1
40	11	Group number not registered for relay broad-casting was specified or the number of addressees specified exceeded the maximum allowable number.	4.13.1
40	12	Retrieval attempted while not ready for retrieval.	4.13.1
40	13	Polled by any other manufacturers' terminal while waiting for secure polling.	4.13.1
40	14	Common key not registered although it needs to be used.	4.13.1
40	15	Black / Red data reception is requested when Black / Red receiving function is disabled.	4.13.3
40	16	Cipher transmission is requested when Cipher receiving function is disabled.	4.13.3
40	17	Invalid resolution selected.	4.13.3
40	20	Invalid full color mode selected.	4.13.3
50	01	Vertical resolution capability changed after compensation of background color.	4.13.3
63	01	"Password + last 4 digits of telephone number" does not match.	4.13.1
63	02	Password not correct	4.13.1
63	03	Polling ID not correct	4.13.1
63	04	Specified confidential ID and MailBox ID do not match.	4.13.1
63	05	Relay broad-casting ID not correct	4.13.1
63	06	Specified Retrieval ID and MailBox Retrieval ID do not match.	4.13.1
63	07	Select receiving ID not correct	4.13.2
63	08	Cipher Key not correct	4.13.2
74	xx	DCN received	4.13.3
80	01	Fallback impossible.	4.13.3
90	01	Unable to detect video signals or commands within 6 seconds after CFR is transmitted.	4.13.3
90	02	Received PPS containing invalid page count or block count.	4.13.3
A0	03	Error correction sequence not terminated even at final transmission speed after fallback.	4.13.3
A0	11	Receive buffer empty (5-second time-out)	4.13.2
A0	12	Receive buffer full during operation except receiving into memory.	4.13.4
A0	13	Decoding error continued on 500 lines or more.	4.13.3

Code 1	Code 2	Cause	Refer to:
A0	14	Decoding error continued for 15 seconds or more.	4.13.3
A0	15	Time-out: 13 seconds or more for one-line transmission.	4.13.3
A0	16	RTC not found or carrier OFF detected for 6 seconds.	4.13.3
A0	17	RTC found but no command detected for 60 seconds or longer.	4.13.3
A0	19	No video data to be sent.	4.13.3
A0	20	Cannot continue receiving color fax (remaining ink low).	4.13.3
A8	01	RTN, PIN, or ERR received (sending terminal).	4.13.3
A9	01	RTN, PIN, or ERR sent (receiving terminal).	4.13.3
AA	18	Receive buffer full during receiving data into memory.	4.13.4
B0	01	Polarity reversion detected.	4.13.2
B0	02	Unable to receive the next-page data.	4.13.2
B0	03	Unable to receive polling during turn-around transmission due to call reservation.	4.13.2
B0	04	PC interface error	4.13.2
C0	01	No common modulation mode or failed to poll.	4.13.3
C0	02	Unable to detect JM.	4.13.3
C0	03	Unable to detect CM.	4.13.3
C0	04	Unable to detect CJ.	4.13.3
C0	10	Cannot finish V. 34 negotiation or training.	4.13.3
C0	11	Modem error detected during V. 34 negotiation or training.	4.13.3
C0	20	Modem error detected while sending commands.	4.13.3
C0	21	Modem error detected while receiving commands.	4.13.3
C0	22	Control channel connection time-out.	4.13.3
C0	30	Modem error detected while sending video signals.	4.13.3
C0	31	Modem error detected while receiving video signals.	4.13.3
E0	01	Failed to detect 1,300 Hz signal in burn-in operation.	4.13.3
E0	02	Failed to detect PB signals in burn-in operation.	4.13.3
E0	03	Unable to detect commands in burn-in operation when RS232C is used.	4.13.3

## 4. TROUBLESHOOTING

---

### 4.1 Error Cause and Remedy

■ **Error code 0102**

ASIC error or motor driver error occurred.

Step	Cause	Remedy
1	Main PCB failure	Replace the main PCB ASSY.

■ **Error code 0201**

Cannot detect the synchronized signal of the paper feed motor. The speed of the paper feed motor does not stabilize within the specified time.

Step	Cause	Remedy
1	Connection failure of the paper feed motor flat cable	Reconnect the paper feed motor flat cable.
2	Connection failure of the low-voltage power supply PCB harness	Reconnect the low-voltage power supply PCB harness.
3	Paper feed motor flat cable failure	Replace the paper feed motor flat cable.
4	Damaged parts in main drive	Replace the frame L unit.
5	Damaged fuser unit	Replace the fuser unit.
6	Low-voltage power supply PCB failure	Replace the low-voltage power supply PCB ASSY.
7	Main PCB failure	Replace the main PCB ASSY.

■ **Error code 0300**

Cannot detect the lock signal of the polygon motor for the laser unit. (second time)

**Error code 0305**

Cannot detect the lock signal of the polygon motor for the laser unit. (first time)

Step	Cause	Remedy
1	Connection failure of the polygon motor harness	Reconnect the polygon motor harness.
2	Laser unit failure	Replace the laser unit.
3	Main PCB failure	Replace the main PCB ASSY.

■ **Error code 0401**

BD sensor failure (second time)

**Error code 0405**

BD sensor failure (first time)

**<User Check>**

- There is a possibility of condensation. Leave the front and back cover open for at least 30 minutes when the power is ON. Close those covers and turn the power switch OFF and then back ON again.

Step	Cause	Remedy
1	Connection failure of the laser unit flat cable	Reconnect the laser unit flat cable.
2	Laser unit failure	Replace the laser unit.
3	Main PCB failure	Replace the main PCB ASSY.

■ **Error code 0501**

The center thermistor of the fuser unit has not reached the specified temperature within the specified time.

**Error code 0502**

The center thermistor of the fuser unit has not reached the specified temperature within the specified time after it was heated normally to the certain level.

**Error code 0503**

The center thermistor of the fuser unit detected a temperature higher than the specified value.

**Error code 0504**

After the heat unit was heated normally, the center thermistor of the fuser unit detected a temperature lower than the specified value.

**Error code 0505**

The center thermistor of the fuser unit detected a temperature rise greater than the specified value within the specified time.

**Error code 0506**

The center thermistor of the fuser unit detected a temperature fall greater than the specified value within the specified time.

**Error code 0508**

Temperature of the end part didn't rise by 1 °C when the fuser unit heater was turned ON.

**Error code 050A**

The hardware detected a temperature error through the center thermistor or the side thermistor of the fuser unit.

**Error code 050B**

When the center thermistor of the fuser unit was lower than the idle temperature, the side thermistor detected a temperature higher than the specified temperature.

**Error code 050C**

When the center thermistor of the fuser unit was higher than the idle temperature, the side thermistor detected a temperature lower than the specified temperature.

**<User Check>**

- Turn OFF the power switch. After several seconds, turn ON the power again and check that this error is reset.

Step	Cause	Remedy
1	Connection failure of the center or side thermistor harness of the fuser unit	Reconnect the center or side thermistor harness of the fuser unit.
2	Connection failure of the heater harness of the fuser unit	Reconnect the heater harness of the fuser unit.
3	Connection failure of the eject sensor PCB harness	Reconnect the eject sensor PCB harness.
4	Connection failure of the low-voltage power supply PCB harness	Reconnect the low-voltage power supply PCB harness.
5	Eject sensor PCB failure	Replace the eject sensor PCB ASSY.
6	Fuser unit failure	Replace the fuser unit.
7	Low-voltage power supply PCB failure	Replace the low-voltage power supply PCB ASSY.
8	Main PCB failure	Replace the main PCB ASSY.

■ **Error code 0900**

Detected irregular power supply for more than 100 times.

Step	Cause	Remedy
1	Low-voltage power supply PCB failure	Replace the low-voltage power supply PCB ASSY. Refer to “1.3.30 Reset irregular power supply detection counter of low-voltage power supply PCB (Function code 88)” in Chapter 5 to reset the irregular power supply detection counter after the replacement.
2	Main PCB failure	Replace the main PCB ASSY.

**Note:**

The irregular power supply detection error (Error code 0900) of the low-voltage power supply PCB occurs when there is a large distortion in the power supply voltage supplied to the machine. In this case, if the same power supply is used, the same error might occur again even if the low-voltage power supply PCB ASSY is replaced. For this reason, be sure to ask the user to rearrange the installation environment.

■ **Error code 0A02**

Detected a fan failure.

Step	Cause	Remedy
1	Connection failure of the fan harness	Reconnect the fan harness.
2	Connection failure of the high-voltage power supply PCB harness	Reconnect the high-voltage power supply PCB harness.
3	Fan failure	Replace the fan.
4	High-voltage power supply PCB failure	Replace the high-voltage power supply PCB ASSY.
5	Main PCB failure	Replace the main PCB ASSY.

■ **Error code 0B01**

An error occurred in the high-voltage power supply PCB ASSY while operating.

**Error code 0B02**

An error occurred in the high-voltage power supply PCB ASSY when the machine was in the ready state.

**<User Check>**

- Slide the green tab of the drum unit to left and right for two to three times to clean the corona wire.
- There is a possibility of condensation. Leave the front and back cover open for at least 30 minutes when the power is ON. Close those covers and turn the power switch OFF and then back ON again.

Step	Cause	Remedy
1	Dirt on the machine, the drum unit, the toner cartridge and the toner box terminal	Clean the machine, the drum unit, the toner cartridge and the toner box terminal. (Refer to Fig. 2-12 (P2-56), Fig. 2-13 (P2-56), Fig. 2-16 (P2-84) and Fig. 2-17 (P2-85).)
2	Connection failure of the high-voltage power supply PCB harness	Reconnect the high-voltage power supply PCB harness.
3	High-voltage power supply PCB failure	Replace the high-voltage power supply PCB ASSY.
4	Main PCB failure	Replace the main PCB ASSY.

■ **Error code 2200**

Cartridge sensor detected that the incompatible toner cartridge was installed.

**Error code 2400**

Toner cartridge is not recognized by the cartridge sensor.

**Error code 2500**

Toner cartridge could not communicate with the cartridge sensor.

**Error code 2E00**

Could not communicate with the cartridge sensor on the machine side.

**<User Check>**

- Replace with a toner cartridge which has a correspondent capacity.

Step	Cause	Remedy
1	Main PCB failure	Replace the main PCB ASSY.

■ **Error code 3A00**

A communication error occurred between the controller and engine in main PCB.

Step	Cause	Remedy
1	Main PCB failure	Replace the main PCB ASSY.

■ **Error code 4000**

Number of the drum unit rotations reaches the upper limit soon.

**Error code 4200**

Number of the drum unit rotations has reached the upper limit. (Printing does not stop.)

<User Check>

- Prepare a new drum unit.

Step	Cause	Remedy
1	If the error display is not cleared after the drum unit in the toner box model has been replaced with a new one.	Refer to "2.3 Resetting Drum Counter" in Chapter 5 and perform the manual new drum detection.
2	Replace the drum unit with a new one and reset the drum counter. If the error display is not cleared, the main PCB is faulty.	Replace the main PCB ASSY.

■ **Error code 4B01**

Dot counter of the toner cartridge or develop roller counter reaches the upper limit soon.

**Error code 4B06**

The amount of toner supplied of the toner box reaches the upper limit soon.

<User Check>

- Prepare a new toner cartridge.

Step	Cause	Remedy
1	Main PCB failure	Replace the main PCB ASSY.

■ **Error code 4C01**

Dot count or develop roller counter of the toner cartridge in models without toner box has reached the upper limit in the toner stop mode.

**Error code 4C06**

The amount of toner supplied of the toner box has reached the upper limit.

**Error code 4D01**

Dot count or develop roller counter of the toner cartridge in models without toner box is reaching the upper limit in the continuous printing mode.

**Error code 4E01**

Toner cartridge in models without toner box has reached the upper limit in the continuous printing mode.

<User Check>

- Replace the toner cartridge whose counter reached the upper limit.

Step	Cause	Remedy
1	Replace the toner cartridge or toner box with a new one and reset the toner counter. If the error display is not cleared, the main PCB is faulty.	Replace the main PCB ASSY.



■ **Error code 4F01**

The new toner sensor of the toner cartridge could not detect a new cartridge properly.

**<User Check>**

- Replace the toner cartridge with a new toner cartridge again.
- If the machine is on the uneven surface, place it on a level surface.

Step	Cause	Remedy
1	Connection failure of the new toner sensor PCB harness	Reconnect the new toner sensor PCB harness.
2	New toner actuator coming off or caught in some sections of the machine	Reattach the new toner actuator.
3	New toner sensor failure	Replace the new toner sensor PCB ASSY.
4	Main PCB failure	Replace the main PCB ASSY.

■ **Error code 4F05**

New process sensor could not detect the new drum unit correctly.

**<User Check>**

- Replace the drum unit with a new drum unit again.
- If the machine is on the uneven surface, place it on a level surface.

Step	Cause	Remedy
1	High-voltage power supply PCB failure	Replace the high-voltage power supply PCB ASSY.
2	Main PCB failure	Replace the main PCB ASSY.

■ **Error code 5E00**

New toner box sensor could not detect the new toner box correctly.

**<User Check>**

- Replace the toner box with a new toner box again.
- If the machine is on the uneven surface, place it on a level surface.

Step	Cause	Remedy
1	New toner box sensor failure	Replace the high-voltage power supply PCB ASSY.
2	Main PCB failure	Replace the main PCB ASSY.

■ **Error code 6001**

The front cover sensor detected that the front cover was open.

**<User Check>**

- Close the front cover.

Step	Cause	Remedy
1	Connection failure of the front cover sensor harness	Reconnect the front cover sensor harness.
2	Front cover failure	Replace the front cover.
3	Front cover sensor failure	Replace the front cover sensor.
4	Main PCB failure	Replace the main PCB ASSY.

■ **Error code 6004**

The eject sensor detected that the fuser cover was open.

**<User Check>**

- Close the fuser cover.

Step	Cause	Remedy
1	Eject actuator coming off or caught in some sections of the machine	Reattach the eject actuator.
2	Fuser cover attachment failure	Reattach the fuser cover.
3	Connection failure of the eject sensor PCB harness	Reconnect the eject sensor PCB harness.
4	Eject sensor PCB failure	Replace the eject sensor PCB ASSY.
5	Main PCB failure	Replace the main PCB ASSY.

■ **Error code 6101**

The new toner sensor detected that no toner cartridge was set.

<User Check>

- Set the toner cartridge correctly.

Step	Cause	Remedy
1	New toner sensor PCB failure	Replace the new toner sensor PCB ASSY.
2	High-voltage power supply PCB failure	Replace the high-voltage power supply PCB ASSY.
3	Main PCB failure	Replace the main PCB ASSY.

■ **Error code 6106**

The new toner box sensor detected that no toner box was set.

<User Check>

- Set the toner box correctly.

Step	Cause	Remedy
1	New toner box actuator coming off or caught in some sections of the machine	Reattach the new toner box actuator.
2	New toner box sensor failure	Replace the high-voltage power supply PCB ASSY.
3	Main PCB failure	Replace the main PCB ASSY.

■ **Error code 6200**

Detected that the drum unit was not set by detecting the electrodes current.

<User Check>

- Set the drum unit correctly.

Step	Cause	Remedy
1	Dirt on the electrodes of the drum unit and those of the machine	Clean the electrodes of the drum unit and those of the machine. (Refer to Fig. 2-12 (P2-56) and Fig. 2-13 (P2-56).)
2	Dirt on the high-voltage power supply PCB terminal	Clean the high-voltage power supply PCB terminal.
3	High-voltage power supply PCB failure	Replace the high-voltage power supply PCB ASSY.
4	Main PCB failure	Replace the main PCB ASSY.

■ Electrodes location of main body

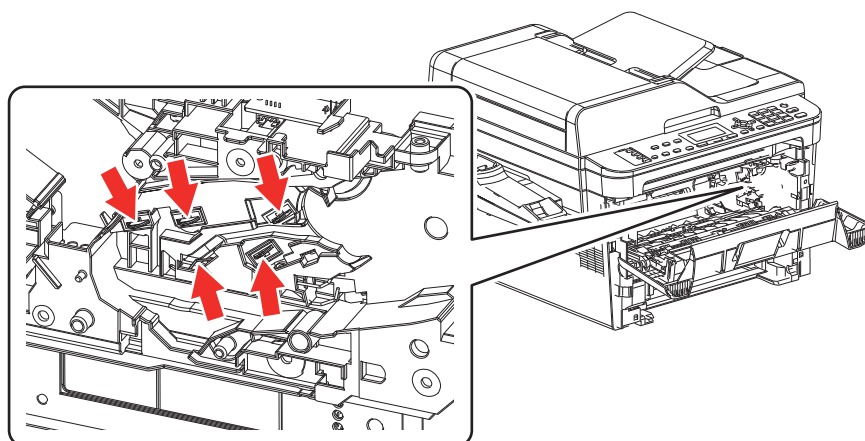


Fig. 2-12

■ Electrodes location of the drum unit and process unit

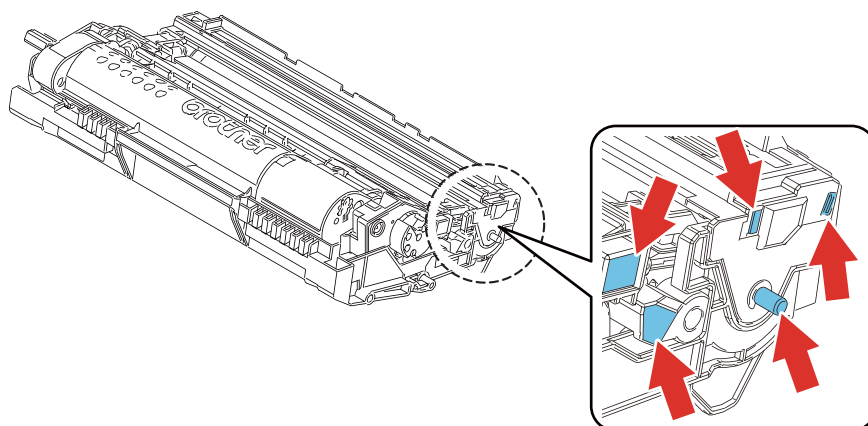


Fig. 2-13

### ■ Error code 6801

The side thermistor detected a temperature higher than the specified value.

#### <User Check>

- Lower the room temperature.
- Keep the machine away from heating appliances.
- Check that the fan is not clogged.

Step	Cause	Remedy
1	Connection failure of the side thermistor harness	Reconnect the side thermistor harness.
2	Fuser unit thermistor failure	Replace the fuser unit.
3	Main PCB failure	Replace the main PCB ASSY.

### ■ Error code 6901

Some fuser unit errors occurred at power-ON or upon recovery from sleep mode.

#### Error code 6902

After the error was detected at the fuser unit, power was turned ON again and the error is being checked. (If power is turned OFF and ON after error code 6901 occurred, this code is displayed for about 15 minutes.)

Step	Cause	Remedy
1	Connection failure of a fuser unit harness	Reconnect the fuser unit harness.
2	Connection failure of the eject sensor PCB harness	Reconnect the eject sensor PCB harness.
3	Fuser unit failure	Replace the fuser unit.
4	Eject sensor PCB failure	Replace the eject sensor PCB ASSY.
5	Low-voltage power supply PCB failure	Replace the low-voltage power supply PCB ASSY.
6	Main PCB failure	Replace the main PCB ASSY.

#### Note:

- Turn OFF the power switch. After the fuser unit has cooled sufficiently, turn ON the power switch again and leave the machine for 15 minutes. This problem may then be cleared.
- To release the fuser unit error after taking appropriate measures, enter the maintenance mode once and quit it with the function code 99.

■ **Error code 6A00**

Electric discharge that may be caused by dirt on the corona wire of the drum unit was detected.

<User Check>

- Slide the green tab of the drum unit to left and right for two to three times to clean the corona wire.
- Clean the electrode of the drum unit. (Refer to [Fig. 2-13 \(P2-56\)](#).)
- Replace the drum unit.

Step	Cause	Remedy
1	Dirt on the electrodes of the machine	Clean the electrodes of the machine. (Refer to <a href="#">Fig. 2-12 (P2-56)</a> .)
2	Dirt on the high-voltage power supply PCB terminal	Clean the high-voltage power supply PCB terminal.
3	High-voltage power supply PCB failure	Replace the high-voltage power supply PCB ASSY.
4	Main PCB failure	Replace the main PCB ASSY.

■ **Error code 6F00**

Detected that supply power is unstable. (less than 100 times)

<User Check>

- Turn the power switch OFF and then back ON again.
- Use a noise filter on the power supply.

Step	Cause	Remedy
1	The power supply waveform is incorrect	Install a voltage stabilizer in the power supply part.

■ **Error code 7000**

After the registration rear sensor detects paper pass, the eject sensor does not detect paper pass.

<User Check>

- Remove the jammed paper.

Step	Cause	Remedy
1	Foreign object inside the machine	Remove the foreign object.
2	Eject actuator coming off or caught in some sections of the machine	Reattach the eject actuator.
3	Fuser cover attachment failure	Reattach the fuser cover.
4	Connection failure of the eject sensor PCB harness	Reconnect the eject sensor PCB harness.
5	Damaged fuser drive gear 64R/36R	Replace the fuser drive gear 64R/36R.
6	Damaged gears in the paper feed drive system	Replace the frame L unit.
7	Eject sensor failure	Replace the eject sensor PCB ASSY.
8	Fuser unit failure	Replace the fuser unit.
9	Main PCB failure	Replace the main PCB ASSY.

■ **Error code 7100**

After the registration rear sensor detects the end of paper pass and the specified period of time has passed, the eject sensor continues to detect paper pass.

**<User Check>**

- Remove the jammed paper.
- Check if the back cover is open during duplex printing.

Step	Cause	Remedy
1	Foreign object in the rear of the machine	Remove the foreign object.
2	Eject actuator caught in some sections of the machine	Reattach the eject actuator.
3	Fuser cover attachment failure	Reattach the fuser cover.
4	Back cover attachment failure	Reattach the back cover.
5	Eject sensor failure	Replace the eject sensor PCB ASSY.
6	Back cover failure	Replace the back cover.
7	Damaged fuser drive gear 64R/36R	Replace the fuser drive gear 64R/36R.
8	Damaged gears in the paper feed drive system	Replace the frame L unit.
9	Fuser unit failure	Replace the fuser unit.
10	Main PCB failure	Replace the main PCB ASSY.

■ **Error code 7200**

When the paper is fed from the MP tray, after the MP paper empty sensor detects paper pass, the registration rear sensor does not detect paper pass after a set period of time.

**<User Check>**

- Remove the jammed paper.
- Add the paper properly using the MP tray paper guide.
- Check if the papers loaded in the MP tray is not held down with your hand.
- Check if the double feed occurs in the MP tray.
- Close the front cover correctly.

Step	Cause	Remedy
1	Foreign object in the rear of the machine	Remove the foreign object.
2	Registration rear actuator coming off or caught in some sections of the machine	Reattach the registration rear actuator.
3	Connection failure of the registration front/rear sensor PCB harness	Reconnect the registration front/rear sensor PCB harness.
4	Registration rear sensor failure	Replace the actuator holder ASSY.
5	Damaged gears in the paper feed drive system	Replace the frame L unit.
6	Main PCB failure	Replace the main PCB ASSY.

■ **Error code 7302**

When printing from the paper tray, the registration front sensor does not detect paper pass within the specified time after the T1 paper feed sensor detected paper pass.

**<User Check>**

- Remove the jammed paper.
- Add the paper properly using the paper guide of paper tray.

Step	Cause	Remedy
1	Foreign object in the front of the machine	Remove the foreign object.
2	Registration front actuator attachment failure	Reattach the registration front actuator.
3	Connection failure of the registration front/rear sensor harness	Reconnect the registration front/rear sensor harness.
4	Registration front/rear sensor PCB failure	Replace the actuator holder ASSY.
5	Damaged gears in the paper feed drive system	Replace the frame L unit.
6	Main PCB failure	Replace the main PCB ASSY.

■ **Error code 7800**

After the first side is printed in 2-sided printing mode, the registration front sensor does not detect paper pass after a set period of time.

**<User Check>**

- Remove the jammed paper.
- Close the back cover correctly.

Step	Cause	Remedy
1	Foreign object in the rear of the machine or duplex tray	Remove the foreign object.
2	Gears in the paper feed system coming off	Reattach the paper feed gear.
3	Duplex tray failure	Replace the duplex tray.
4	Damaged gears in the paper feed drive system	Replace the frame L unit.
5	Main PCB failure	Replace the main PCB ASSY.



■ **Error code 8903**

The back cover sensor detected the open state when 2-sided printing is started (before the registration of printing in the engine).

**Error code 8904**

The back cover sensor detected the open state during 2-sided printing (after the registration of printing in the engine).

**<User Check>**

- Close the back cover correctly.
- Check that the duplex tray is set correctly.

Step	Cause	Remedy
1	Duplex tray is not set correctly	Reattach the duplex tray correctly.
2	Back cover sensor attachment failure	Reattach the back cover sensor.
3	Breakage of boss that presses the back cover sensor	Replace the back cover.
4	Guide which pushes the back cover sensor of the duplex tray is faulty	Replace the duplex tray.
5	Back cover sensor failure	Replace the eject sensor PCB ASSY.
6	Main PCB failure	Replace the main PCB ASSY.

■ **Error code 8A01**

The registration rear sensor detected that the paper fed was smaller or larger than the specified size in duplex printing mode.

**<User Check>**

- Use appropriate paper (Letter to Legal).

Step	Cause	Remedy
1	Registration rear actuator caught in some sections of the machine	Reattach the registration rear actuator.
2	Registration rear sensor failure	Replace the actuator holder ASSY.
3	Main PCB failure	Replace the main PCB ASSY.

■ **Error code 8C00**

There is no paper set in the manual feed slot on the manual feed slot printing.

**<User Check>**

- Set the paper in the manual feed slot.

Step	Cause	Remedy
1	Registration front actuator caught in some sections of the machine	Reattach the registration front actuator.
2	Connection failure of the registration front/rear sensor PCB harness	Reconnect the registration front/rear sensor PCB harness.
3	Registration front sensor failure	Replace the actuator holder ASSY.
4	Main PCB failure	Replace the main PCB ASSY.

■ **Error code 8E01**

Paper size is not set as A4/Letter/Legal/Folio when receiving fax or printing a list/report.

**Error code 8E02**

Detected that the size of paper set in the paper tray was over 10 mm shorter than paper size set in the machine during faxing or printing a list or report.

**<User Check>**

- Set A4 or Letter-size paper.

Step	Cause	Remedy
1	Registration rear actuator caught in some sections of the machine	Reattach the registration rear actuator.
2	Registration rear sensor failure	Replace the actuator holder ASSY.
3	Main PCB failure	Replace the main PCB ASSY.

■ **Error code 9001**

The size of paper loaded in the MP tray and the one specified from the driver are not same when paper is fed from the MP tray.

**Error code 9002**

The size of paper loaded in the paper tray and the one specified from the driver are not same when paper is fed from the paper tray.

**<User Check>**

- Change the driver setting to be matched with the size of the paper set in the paper tray.

Step	Cause	Remedy
1	Registration rear actuator caught in some sections of the machine	Reattach the registration rear actuator.
2	Registration rear sensor failure	Replace the actuator holder ASSY.
3	Main PCB failure	Replace the main PCB ASSY.

■ **Error code 9201**

When printing from the MP tray, paper type setting in the machine does not match the setting in the driver.

**Error code 9202**

When printing from the paper tray, paper type setting in the machine does not match the setting in the driver.

**<User Check>**

- Use the same paper type setting for the machine and driver.

Step	Cause	Remedy
1	Malfunction of the main PCB	Install the latest main firmware.
2	Main PCB failure	Replace the main PCB ASSY.

■ **Error code 9301**

When paper was fed from the MP tray, the MP paper empty sensor detected that no paper was in the MP tray.

**<User Check>**

- Load paper to the MP tray.

Step	Cause	Remedy
1	MP paper empty actuator caught in some sections of the machine	Reattach the MP paper empty actuator.
2	Connection failure of the MP paper empty sensor PCB harness	Reconnect the MP paper empty sensor PCB harness.
3	Connection failure of the MP relay PCB harness	Reconnect the MP relay PCB harness.
4	Main PCB failure	Replace the main PCB ASSY.

■ **Error code 9302**

When paper was fed from the paper tray, the T1 paper empty sensor or T1 paper feed sensor detected that no paper was in the paper tray.

**<User Check>**

- Set paper in the paper tray.

Step	Cause	Remedy
1	Connection failure of the T1 paper empty/paper feed sensor harness (paper empty sensor models only)	Reconnect the T1 paper empty/paper feed sensor harness.
2	Connection failure of the T1 clutch harness	Reconnect the T1 clutch harness.
3	Connection failure of the paper feed motor flat cable	Reconnect the paper feed motor flat cable.
4	T1 paper feed actuator caught in some sections of the machine (non paper empty sensor models only)	Reattach the T1 paper feed actuator.
5	T1 paper empty actuator caught in some sections of the machine (paper empty sensor models only)	Reattach the T1 paper empty actuator.
6	Abrasion of the PF kit 1	Replace the PF kit 1.
7	Paper feed motor flat cable failure	Replace the paper feed motor flat cable.
8	T1 clutch failure	Replace the T1 clutch.
9	T1 paper feed sensor PCB failure (non paper empty sensor models only)	Replace the T1 paper feed sensor PCB ASSY.
10	Paper feed motor failure	Replace the paper feed motor.
11	Damaged gears in the paper feed drive system	Replace the frame L unit.
12	Main PCB failure	Replace the main PCB ASSY.

■ **Error code 9309**

Detected that there was no paper set in all trays when TrayAuto was selected for printing.

**<User Check>**

- Set paper in the paper tray.

Step	Cause	Remedy
1	Connection failure of the MP paper empty sensor PCB harness	Reconnect the MP paper empty sensor PCB harness.
2	Connection failure of the T1 paper feed sensor harness (non paper empty sensor models only)	Reconnect the T1 paper feed sensor harness.
3	Connection failure of the T1 paper empty/paper feed sensor harness (paper empty sensor models only)	Reconnect the T1 paper empty/paper feed sensor harness.
4	Connection failure of the T1 clutch harness	Reconnect the T1 clutch harness.
5	T1/MP paper empty actuator caught in some sections of the machine (paper empty sensor models only)	Reattach the T1/MP paper empty actuator.
6	T1 paper feed actuator caught in some sections of the machine (non paper empty sensor models only)	Reattach the T1 paper feed actuator.
7	Abrasion of the PF kit 1	Replace the PF kit 1.
8	T1 paper empty/paper feed sensor PCB failure (paper empty sensor models only)	Replace the T1 paper empty/paper feed sensor PCB ASSY.
9	T1 paper feed sensor PCB failure (non paper empty sensor models only)	Replace the T1 paper feed sensor PCB ASSY.
10	T1 clutch failure	Replace the T1 clutch.
11	Damaged gears in the paper feed drive system	Replace the frame L unit.
12	Main PCB failure	Replace the main PCB ASSY.

■ **Error code 9701**

For 2-sided printing, paper size setting of the printer driver that was not supported by 2-sided printing was selected.

**Error code 9702**

For printing by feeding paper from the paper tray, the size of paper specified from the driver set the size which was not supported by the paper tray.

**<User Check>**

- Select the specified paper size in the driver and set paper with the same size to the specified paper tray.

Step	Cause	Remedy
1	Main PCB failure	Replace the main PCB ASSY.

■ **Error code A000**

Image processing was not completed correctly because the number of pixels required for image processing is insufficient in the scanned second side data.

Step	Cause	Remedy
1	Incorrect correction data for second side CIS unit	Execute "Set CIS scan area (Function code 55)".
2	Second side CIS unit failure	Replace the second side CIS unit.
3	Main PCB failure	Replace the main PCB ASSY.

■ **Error code A200**

The document scanning position sensor detected that the document length was 90 cm or more during the one-side scanning.

<User Check>

- Use the paper less than A4 size.
- Remove the jammed document.

Step	Cause	Remedy
1	Document scanning position actuator caught in some sections of the machine	Reattach the document scanning position actuator.
2	Document scanning position sensor failure	Replace the ADF unit.
3	Main PCB failure	Replace the main PCB ASSY.

■ **Error code A300**

The document scanning position sensor has not detected the document passing even after the document has been fed for the specified time.

<User Check>

- Adjust the document guide to suit the document size.
- Remove the jammed document.

Step	Cause	Remedy
1	Foreign object inside the ADF	Remove the foreign objects inside the ADF.
2	Document scanning position actuator caught in some sections of the machine	Reattach the document scanning position actuator.
3	Connection failure of the document scanning position sensor harness	Reconnect the document scanning position sensor harness.
4	Document scanning position sensor failure	Replace the ADF unit.
5	Main PCB failure	Replace the main PCB ASSY.

■ **Error code A400**

The ADF cover sensor detected that the ADF cover was open.

<User Check>

- Close the ADF cover correctly.

Step	Cause	Remedy
1	ADF cover actuator caught in some sections of the machine	Reattach the ADF cover actuator.
2	ADF cove sensor attachment failure	Reattach the ADF cover sensor.
3	ADF cover attachment failure	Reattach the ADF cover.
4	Connection failure of the ADF cover sensor harness	Reconnect the ADF cover sensor harness.
5	Damaged ADF cover	Replace the ADF cover.
6	ADF cover sensor failure	Replace the ADF unit.
7	Main PCB failure	Replace the main PCB ASSY.

■ **Error code A500**

When scanning the fax, white or black correction data for the first side CIS unit was not within the correct range (first time).

**Error code A600**

When scanning the fax, white or black correction data for the first side CIS unit was not within the correct range (second time).

Step	Cause	Remedy
1	Incorrect correction data for first side CIS unit	Execute "Acquire white level data (Function code 55)".
2	Dirt on the white tape on the second side document hold	Clean the white tape on the second side document hold.
3	Damaged first side CIS flat cable	Replace the first side CIS flat cable.
4	First side CIS unit failure	Replace the first side CIS unit.
5	White tape failure	Replace the document scanner unit.
6	Main PCB failure	Replace the main PCB ASSY.

■ **Error code A700**

Color parameter in the ROM does not match the first side or second side CIS.

**Error code A900**

A scanning error occurred while processing the scanned image.

Step	Cause	Remedy
1	Incorrect correction data for first side or second side CIS unit	Execute "Set CIS scan area (Function code 55)".
2	Damaged first side CIS flat cable	Replace the first side CIS flat cable.
3	Damaged second side CIS flat cable	Replace the second side CIS flat cable.
4	First side CIS unit failure	Replace the first side CIS unit.
5	Second side CIS unit failure	Replace the second side CIS unit.
6	Main PCB failure	Replace the main PCB ASSY.

■ **Error code AC00**

When scanning the fax, white or black correction data for the second side CIS was not within the correct range (first time).

Step	Cause	Remedy
1	Incorrect correction data for second side CIS unit	Execute "Acquire white level data (Function code 55)".
2	Dirt on the white tape on the second side document hold	Clean the white tape on the second side document hold.
3	Damaged second side CIS flat cable	Replace the second side CIS flat cable.
4	Second side CIS unit failure	Replace the second side CIS unit.
5	White tape failure	Replace the ADF unit.
6	Main PCB failure	Replace the main PCB ASSY.

■ **Error code AD00**

Image processing cannot be completed correctly because the number of pixels required for image processing is insufficient in the scanned first side data.

Step	Cause	Remedy
1	Incorrect correction data for first side CIS unit	Execute "Set CIS scan area (Function code 55)".
2	Connection failure of the first side CIS flat cable	Reconnect the first side CIS flat cable.
3	First side CIS unit failure	Replace the first side CIS unit.
4	White tape failure	Replace the document scanner unit.
5	Main PCB failure	Replace the main PCB ASSY.

■ **Error code AF00**

Home position is still being detected even after the first side CIS unit was moved.

Step	Cause	Remedy
1	Dust on the CIS guide shaft	Remove the dust on the CIS guide shaft.
2	CIS drive belt coming off	Reattach the CIS drive belt.
3	Wrong wiring of the first side CIS flat cable	Reattach the first side CIS flat cable.
4	Connection failure of the FB motor harness	Reconnect the FB motor harness.
5	Connection failure of the first side CIS flat cable	Reconnect the first side CIS flat cable.
6	Damaged first side CIS flat cable	Replace the first side CIS flat cable.
7	First side CIS unit failure	Replace the first side CIS unit.
8	FB motor failure	Replace the document scanner unit.
9	Main PCB failure	Replace the main PCB ASSY.

■ **Error code B000**

Detected that the first side CIS flat cable or second side CIS flat cable was not inserted correctly when function code 55 was executed.

Step	Cause	Remedy
1	Connection failure of the first side CIS flat cable	Reconnect the first side CIS flat cable.
2	Connection failure of the second side CIS flat cable	Reconnect the second side CIS flat cable.
3	Damaged first side CIS flat cable	Replace the first side CIS flat cable.
4	Damaged second side CIS flat cable	Replace the second side CIS flat cable.
5	First side CIS unit failure	Replace the first side CIS unit.
6	Second side CIS unit failure	Replace the second side CIS unit.
7	Main PCB failure	Replace the main PCB ASSY.



■ **Error code BB00**

A white level not within the standard was scanned when function code 55 was executed.

Step	Cause	Remedy
1	Dirt on the second side document hold	Clean the second side document hold.
2	Dirt on the white tape	Clean the white tape.
3	First side CIS unit failure	Replace the first side CIS unit.
4	Second side CIS unit failure	Replace the second side CIS unit.
5	Second side document hold failure	Replace the ADF unit.
6	White tape failure	Replace the document scanner unit.
7	Main PCB failure	Replace the main PCB ASSY.

■ **Error code BC00**

When scanning the fax, white or black correction data for the second side CIS was not within the correct range (second time).

Step	Cause	Remedy
1	Incorrect correction data for second side CIS unit	Execute "Acquire white level data (Function code 55)".
2	Dirt on the white tape on the second side document hold	Clean the white tape on the second side document hold.
3	Damaged second side CIS flat cable	Replace the second side CIS flat cable.
4	Second side CIS unit failure	Replace the second side CIS unit.
5	White tape failure	Replace the ADF unit.
6	Main PCB failure	Replace the main PCB ASSY.

■ **Error code BD00**

A black level not within the standard was scanned when function code 55 was executed.

Step	Cause	Remedy
1	Dirt on the second side document hold	Clean the second side document hold.
2	Dirt on the white tape	Clean the white tape.
3	First side CIS unit failure	Replace the first side CIS unit.
4	Second side CIS unit failure	Replace the second side CIS unit.
5	Second side document hold failure	Replace the ADF unit.
6	White tape failure	Replace the document scanner unit.
7	Main PCB failure	Replace the main PCB ASSY.

■ **Error code BF00**

The document scanning position sensor detected that the document length was 400 mm or longer and could not be fed to ADF (double-side restoration).

**<User Check>**

- Set the specified size paper.

Step	Cause	Remedy
1	Document scanning position actuator caught in some sections of the machine	Reattach the document scanning position actuator.
2	Document scanning position sensor failure	Replace the ADF unit.
3	Main PCB failure	Replace the main PCB ASSY.

■ **Error code C700**

The memory is insufficient to expand the data of PC-Print.

**Error code C800**

The memory used to store secure print data exceeded the memory size for secure print data.

**<User Check>**

- Print the print data stored in the memory.
- Divide the print data and print them separately.

Step	Cause	Remedy
1	Main PCB failure	Replace the main PCB ASSY.

■ **Error code D100**

An error occurred while initializing the modem.

**Error code D200**

Detected that the modem PCB is not connected.

Step	Cause	Remedy
1	Connection failure of the modem flat cable	Reconnect the modem flat cable.
2	Modem flat cable failure	Replace the modem flat cable.
3	Modem PCB failure	Replace the modem PCB ASSY.
4	Main PCB failure	Replace the main PCB ASSY.

■ **Error code D800**

An error occurred while initializing the touch panel.

Step	Cause	Remedy
1	Connection failure of the panel flat cable	Reconnect the panel flat cable.
2	Connection failure of the key PCB flat cable	Reconnect the key PCB flat cable.
3	Touch panel ASSY failure	Replace the touch panel ASSY.
4	Key PCB failure	Replace the key PCB ASSY.
5	Panel PCB failure	Replace the panel PCB ASSY.
6	Panel ASSY failure	Replace the panel ASSY.
7	Main PCB failure	Replace the main PCB ASSY.

■ **Error code E000**

An error occurred in the ROM check sum.

**Error code E100**

Program error

<User Check>

- Install the latest main firmware.

Step	Cause	Remedy
1	Main PCB failure	Replace the main PCB ASSY.

■ **Error code E500**

An error occurred during access to the DRAM in the main PCB ASSY.

**Error code E600**

Write error in the EEPROM of the main PCB ASSY

**Error code E701**

System error in the flash ROM

**Error code E702**

Read error in the flash ROM

Step	Cause	Remedy
1	Main PCB failure	Replace the main PCB ASSY.

### ■ Error code E900

An error occurred while initializing the NFC.

Step	Cause	Remedy
1	Connection failure of the panel flat cable	Reconnect the panel flat cable.
2	Connection failure of the NFC flat cable	Reconnect the NFC flat cable.
3	Panel PCB failure	Replace the panel PCB ASSY.
4	NFC PCB failure	Replace the NFC PCB ASSY.
5	Main PCB failure	Replace the main PCB ASSY.

### ■ Error code F900

The spec code was not entered correctly.

Step	Cause	Remedy
1	The power was turned OFF while function code 74 was running.	Reenter the spec code. (Refer to "1.3.23 Configure for country/region and model (Function code 74)" in Chapter 5.)
2	Main PCB failure	Replace the main PCB ASSY.

#### **Memo:**

- For non touch panel models, simultaneously pressing the [\*] and the [#] clears the error display under error code F900 display, and then the maintenance mode can be selected again.
- For touch panel models, pressing the [\*] or the [#] clears the error display under error code F900 display, and then the maintenance mode can be selected again.
- For DCP models, press the [▲] or the [▼] under error code F900 display to select the maintenance mode.

## 4.2 Troubleshooting for Paper Feeding Problems

Problems related to paper feeding are end user recoverable if following the User Check items. If the same problem occurs again, follow each procedure in the order of the number described in the Step column in the tables below.

### 4.2.1 No paper feeding from paper tray

#### <User Check>

- Check that the paper is set in the paper tray correctly.
- Check that there is not too much paper set in the paper tray.
- Flip over the paper in the paper tray or rotate the paper 180°.
- Check that the thickness of the paper is 60 to 163 g/m<sup>2</sup>.
- Check that the MP tray is not set as the paper tray.
- Flip through the paper and reset it in the paper tray.
- Clean the paper pick up roller.

Step	Cause	Remedy
1	Dirt on the paper dust cleaning roller of the paper tray	Refer to the figure below to clean the paper dust cleaning roller and inside of the paper dust cleaning roller cover.
2	T1 roller holder ASSY attachment failure	Reattach the T1 roller holder ASSY correctly.
3	Connection failure of the paper feed motor flat cable	Reconnect the paper feed motor flat cable.
4	Connection failure of the T1 paper feed sensor harness (non paper empty sensor models only)	Reconnect the T1 paper feed sensor harness.
5	Connection failure of the T1 clutch harness	Reconnect the T1 clutch harness.
6	Connection failure of the T1 paper empty/paper feed sensor harness (paper empty sensor models only)	Reconnect the T1 paper empty/paper feed sensor harness.
7	T1 paper empty actuator coming off	Reattach the T1 paper empty actuator.
8	Abrasion of the paper pick up roller	Replace the PF kit 1.
9	T1 paper feed sensor failure (non paper empty sensor models only)	Replace the T1 paper feed sensor PCB ASSY.
10	T1 paper empty sensor failure (paper empty sensor models only)	Replace the T1 paper empty/paper feed sensor PCB ASSY.
11	Paper feed motor flat cable failure	Replace the paper feed motor flat cable.
12	Paper feed motor failure	Replace the paper feed motor.
13	Damaged gears in the paper feed drive system	Replace the frame L unit.
14	Damaged fuser unit	Replace the fuser unit.
15	Main PCB failure	Replace the main PCB ASSY.

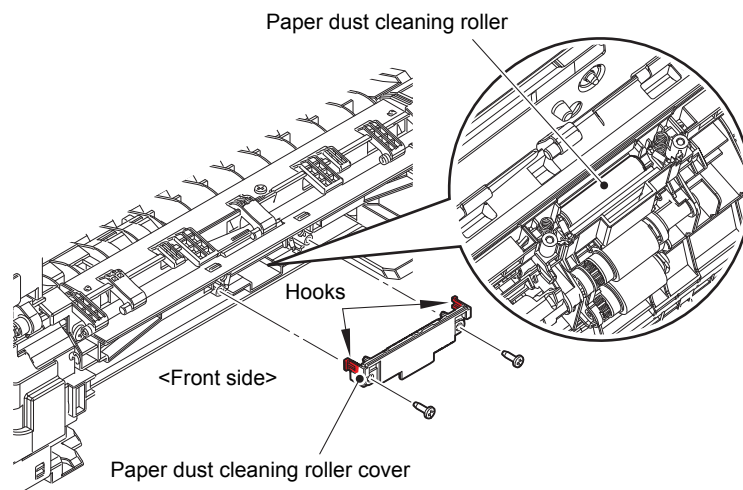


Fig. 2-14

## 4.2.2 No paper feeding from MP tray

### <User Check>

- Check that the paper is set in the MP tray deeply.
- Check that too much paper is not loaded in the MP tray.
- Check if the machine is used with the MP tray support and MP flap are in closed state.
- Check that the thickness of the paper is 60 to 230 g/m<sup>2</sup>.
- Check that the paper tray is not set as the paper tray by the printer driver.
- Flip through the paper and reset it in the MP tray.
- Clean the MP paper pick-up roller.
- Check whether the paper tray is closed correctly.

Step	Cause	Remedy
1	MP roller holder ASSY attachment failure	Reattach the MP roller holder ASSY correctly.
2	Connection failure of the paper feed motor flat cable	Reconnect the paper feed motor flat cable.
3	Connection failure of the MP paper empty/registration front sensor harness	Reconnect the MP paper empty/registration front sensor harness.
4	Paper feed motor flat cable failure	Replace the paper feed motor flat cable.
5	Paper feed motor failure	Replace the paper feed motor.
6	Damaged gears in the paper feed drive system	Replace the frame L unit.
7	Damaged fuser unit	Replace the fuser unit.
8	Main PCB failure	Replace the main PCB ASSY.

### 4.2.3 No paper feeding from manual feed slot

#### <User Check>

- Check that the paper is set into the deepest part of the manual feed slot.
- Check that multiple sheets of paper are not set in the manual feed slot.
- Check that the thickness of the paper is 60 to 230 g/m<sup>2</sup>.
- Check that the paper tray is not set as the pick-up tray.
- Check that the paper tray is closed correctly.

Step	Cause	Remedy
1	T1 roller holder ASSY attachment failure	Reattach the T1 roller holder ASSY.
2	Connection failure of the paper feed motor flat cable	Reconnect the paper feed motor flat cable.
3	Connection failure of the registration front/rear sensor harness	Reconnect the registration front/rear sensor harness.
4	Abrasion of the paper pick up roller	Replace the PF kit 1.
5	Paper feed motor flat cable failure	Replace the paper feed motor flat cable.
6	Registration front sensor failure	Replace the actuator holder ASSY.
7	Paper feed motor failure	Replace the paper feed motor.
8	Damaged gears in the paper feed drive system	Replace the frame L unit.
9	Damaged fuser unit	Replace the fuser unit.
10	Main PCB failure	Replace the main PCB ASSY.

### 4.2.4 Multiple sheets of paper are fed

#### <User Check>

- Check that there is not too much paper set in each paper tray.
- Check that the paper is set in each paper tray correctly.
- Flip over the paper in each paper tray or rotate the paper 180°.
- Check that the thickness of the paper is 60 to 163 g/m<sup>2</sup> for the paper tray, and 60 to 230 g/m<sup>2</sup> for the MP tray.
- Flip through the paper and reset it in the paper tray.

Step	Cause	Remedy
1	Abrasion of the separation pad	Replace the PF kit.

## 4.2.5 Paper becomes wrinkled

### <User Check>

- Check that the paper is set in each paper tray correctly.
- Flip over the paper in each paper tray or rotate the paper 180°.
- Adjust each paper guide according to each paper size.
- Check that the thickness of the paper is 60 to 163 g/m<sup>2</sup> for the paper tray, and 60 to 230 g/m<sup>2</sup> for the MP tray.
- Check that the paper is not damp.
- Check that there is no dust stuck to the fuser unit.
- Check that the type of paper is appropriate.
- Check that the paper size is matched to the setting for the duplex printer.

Step	Cause	Remedy
1	Paper eject ASSY failure	Replace the paper eject ASSY.
2	Fuser unit failure	Replace the fuser unit.

## 4.2.6 Paper is fed at an angle

### <User Check>

- Check that the paper is set in each paper tray correctly.
- Flip over the paper in each paper tray or rotate the paper 180°.
- Adjust each paper guide according to each paper size.
- Check that the thickness of the paper is 60 to 163 g/m<sup>2</sup> for the paper tray, and 60 to 230 g/m<sup>2</sup> for the MP tray.
- Check that there is not too much paper set in the paper tray.
- Check that the type of paper is appropriate.
- Clean each paper pick up roller.
- Check that the green envelope lever is not lowered on only one side.

Step	Cause	Remedy
1	One-side abrasion of the paper pick up rollers	Replace the PF kit.
2	Paper feed unit failure	Replace the paper feed unit.



## 4.2.7 Paper curls

### <User Check>

- Change the driver setting to be matched with the size of the paper set in the paper tray.
- Select “Reduce Paper Curl” in the driver.
- Check that the paper is set in each paper tray correctly.
- Open the back cover and try printing with straight paper ejection mode.
- Check that the paper is not damp.

Step	Cause	Remedy
1	Fuser unit failure	Replace the fuser unit.
2	Main PCB failure	Replace the main PCB ASSY.

## 4.2.8 Unable to perform 2-sided printing

### <User Check>

- Close the back cover completely.
- Close the paper tray completely.
- Set the driver setting to duplex printing.
- Use A4 or Letter paper specified by the manufacturer.

Step	Cause	Remedy
1	Eject actuator coming off	Reattach the eject actuator.
2	Back cover failure	Replace the back cover.
3	Eject sensor failure	Replace the eject sensor PCB ASSY.
4	Duplex tray failure	Replace the duplex tray.
5	Damaged gears in the ejecting system	Replace the frame L unit.
6	Main PCB failure	Replace the main PCB ASSY.

## 4.2.9 Paper jam

### ■ Paper jam at the paper tray

#### <User Check>

- Check that the paper is set in the paper tray correctly.
- Flip over the paper in the paper tray or rotate the paper 180°.
- Adjust each paper guide according to the paper size.
- Check that there is not too much paper set.
- Check that the thickness of the paper is 60 to 163 g/m<sup>2</sup>.
- Flip through the paper and reset it in the paper tray.

Step	Cause	Remedy
1	Foreign object around the paper tray	Remove the foreign object.
2	Paper dust cleaning roller attachment failure	Reattach the paper dust cleaning roller.
3	Paper feed actuator coming off	Reattach the paper feed actuator.
4	Registration front actuator coming off	Reattach the registration front actuator.
5	Connection failure of the registration front/rear sensor harness	Reconnect the registration front/rear sensor harness.
6	Connection failure of the registration clutch harness	Reconnect the registration clutch harness.
7	Connection failure of the T1 paper feed sensor harness (non paper empty sensor models only)	Reconnect the T1 paper feed sensor harness.
8	Connection failure of the T1 paper empty/paper feed sensor harness (paper empty sensor models only)	Reconnect the T1 paper empty/paper feed sensor harness.
9	Registration front sensor failure	Replace the actuator holder ASSY.
10	T1 paper feed sensor failure (non paper empty sensor models only)	Replace the T1 paper feed sensor PCB ASSY.
11	T1 paper empty sensor failure (paper empty sensor models only)	Replace the T1 paper empty/paper feed sensor PCB ASSY.
12	Paper feed motor failure	Replace the paper feed motor.
13	Damaged gears in the paper feed drive system	Replace the frame L unit.
14	Damaged fuser unit	Replace the fuser unit.
15	Main PCB failure	Replace the main PCB ASSY.

■ Paper jam at the MP tray

<User Check>

- Check that the paper is set in the MP tray correctly.
- Flip over the paper in the MP tray or rotate the paper 180°.
- Adjust each paper guide according to each paper size.
- Check that there is not too much paper set.
- Check that the thickness of the paper is 60 to 230 g/m<sup>2</sup>.
- Flip through the paper and reset it in the MP tray.

Step	Cause	Remedy
1	Foreign object around the MP tray	Remove the foreign object.
2	Connection failure of the MP paper empty/registration front sensor harness	Reconnect the MP paper empty/ registration front sensor harness.
3	MP registration front actuator coming off	Reattach the MP registration front actuator.
4	Connection failure of the registration clutch harness	Reconnect the registration clutch harness.
5	Paper feed motor failure	Replace the paper feed motor.
6	Damaged gears in the MP paper feed system	Replace the frame L unit.
7	Damaged fuser unit	Replace the fuser unit.
8	Main PCB failure	Replace the main PCB ASSY.

■ Paper jam at the manual feed slot

<User Check>

- Check that the paper is set in the manual feed slot correctly.
- Flip over the paper in the manual feed slot or rotate the paper 180°.
- Adjust the paper guide according to the paper size.
- Check that multiple sheets of paper are not set.
- Check that the thickness of the paper is 60 to 230 g/m<sup>2</sup>.

Step	Cause	Remedy
1	Foreign object around the manual feed slot	Remove the foreign object.
2	Connection failure of the registration front/rear sensor harness	Reconnect the registration front/rear sensor harness.
3	T1 registration front actuator coming off	Reattach the T1 registration front actuator.
4	Connection failure of the registration clutch harness	Reconnect the registration clutch harness.
5	Registration front/rear sensor failure	Replace the actuator holder ASSY.
6	Paper feed motor failure	Replace the paper feed motor.
7	High-voltage power supply PCB failure	Replace the high-voltage power supply PCB ASSY.
8	Damaged gears in the paper feed drive system	Replace the frame L unit.
9	Fuser unit failure	Replace the fuser unit.
10	Main PCB failure	Replace the main PCB ASSY.

■ Paper jam at the paper feeding section at the center of the machine

<User Check>

- Check that the paper is set in each paper tray correctly.
- Flip over the paper in each paper tray or rotate the paper 180°.
- Adjust each paper guide according to the paper size.
- Check that there is not too much paper set in each paper tray.
- Check that the thickness of the paper is 60 to 163 g/m<sup>2</sup> for the paper tray, and 60 to 230 g/m<sup>2</sup> for the MP tray.
- Flip through the paper and reset it in the paper tray.
- Replace the drum unit.

Step	Cause	Remedy
1	Foreign object inside the machine	Remove the foreign object.
2	Eject actuator coming off	Reattach the eject actuator.
3	Connection failure of the eject sensor harness	Reconnect the eject sensor harness.
4	Fuser cover attachment failure	Reattach the fuser cover.
5	Damaged fuser drive gear	Replace the fuser drive gear.
6	Eject sensor failure	Replace the eject sensor PCB ASSY.
7	Registration rear sensor failure	Replace the actuator holder ASSY.
8	Paper feed motor failure	Replace the paper feed motor.
9	Damaged gears in the paper feed drive system	Replace the frame L unit.
10	Damaged fuser unit	Replace the fuser unit.
11	Main PCB failure	Replace the main PCB ASSY.

■ **Paper jam at the eject section**

**<User Check>**

- Check that the paper is set in each paper tray correctly.
- Flip over the paper in each paper tray or rotate the paper 180°.
- Adjust each paper guide according to the paper size.
- Check that there is not too much paper set in each paper tray.
- Check that the thickness of the paper is 60 to 163 g/m<sup>2</sup> for the paper tray, and 60 to 230 g/m<sup>2</sup> for the MP tray.
- Flip through the paper and reset it in the paper tray.

Step	Cause	Remedy
1	Foreign object in the rear of the machine	Remove the foreign object.
2	Eject actuator coming off	Reattach the eject actuator.
3	Connection failure of the eject sensor harness	Reconnect the eject sensor harness.
4	Fuser cover attachment failure	Reattach the fuser cover.
5	Eject sensor failure	Replace the eject sensor PCB ASSY.
6	Paper feed motor failure	Replace the paper feed motor.
7	Damaged gears in the paper feed drive system	Replace the frame L unit.
8	Damaged fuser unit	Replace the fuser unit.
9	Main PCB failure	Replace the main PCB ASSY.

■ **Paper jam at the duplex tray**

**<User Check>**

- Flip over the paper in each paper tray or rotate the paper 180°.
- Check that the thickness of the paper is 60 to 105 g/m<sup>2</sup> for the duplex tray.
- Flip through the paper and reset it in the paper tray.
- Use paper specified by the manufacturer.
- Check that the paper size is matched to the setting for the duplex printer.

Step	Cause	Remedy
1	Foreign object in the duplex paper feeding system	Remove the foreign object.
2	Fuser cover attachment failure	Reattach the fuser cover.
3	Back cover failure	Replace the back cover.
4	Duplex tray failure	Replace the duplex tray.
5	Main PCB failure	Replace the main PCB ASSY.

## 4.3 Troubleshooting for Image Defects

### 4.3.1 Image defect examples

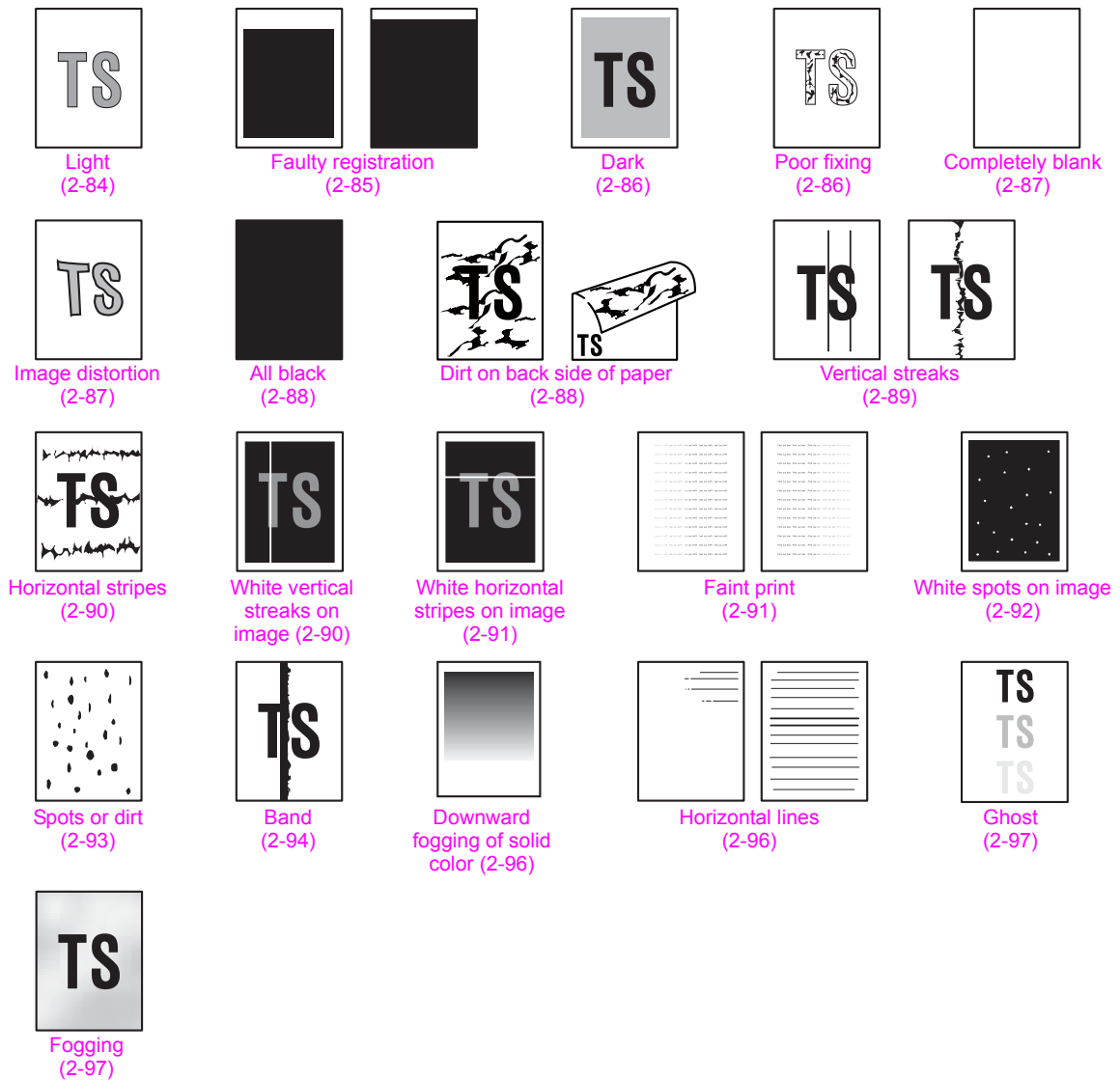


Fig. 2-15

### 4.3.2 Troubleshooting image defect

Image defect related problems are end user recoverable if following the User Check items. If the same problem occurs again, follow each procedure in the order of the number described in the Step column in the tables below.

#### ■ Light



##### <User Check>

- Check the usage environment of the machine. Using the machine in hot-humid or cold-dry conditions can cause this problem.
- If the whole page is light, toner save mode may be ON. Turn OFF the toner save mode.
- Replace the drum unit with a new one.
- Replace the toner cartridge with a new one.
- Turn ON the power switch, and leave the machine for a while (condensation).
- Check if paper is not damp.
- Use specified paper.

Step	Cause	Remedy
1	Dirt on the electrodes of the drum unit and those of the machine	Clean the electrodes of the drum unit and those of the machine. (Refer to Fig. 2-12 (P2-56) and Fig. 2-13 (P2-56).)
2	Dirt on the electrodes of the toner cartridge and those of the machine	Clean the electrodes of the toner cartridge, process unit and those of the machine. (Refer to Fig. 2-12 (P2-56), below and Fig. 2-17 (P2-85).)
3	Dirt on the electrodes of the high-voltage power supply PCB and those of the machine	Clean the electrodes of the high-voltage power supply PCB and those of the machine.
4	Fuser unit failure	Replace the fuser unit.
5	High-voltage power supply PCB failure	Replace the high-voltage power supply PCB ASSY.
6	Main PCB failure	Replace the main PCB ASSY.

#### ■ Electrodes location of the toner cartridge

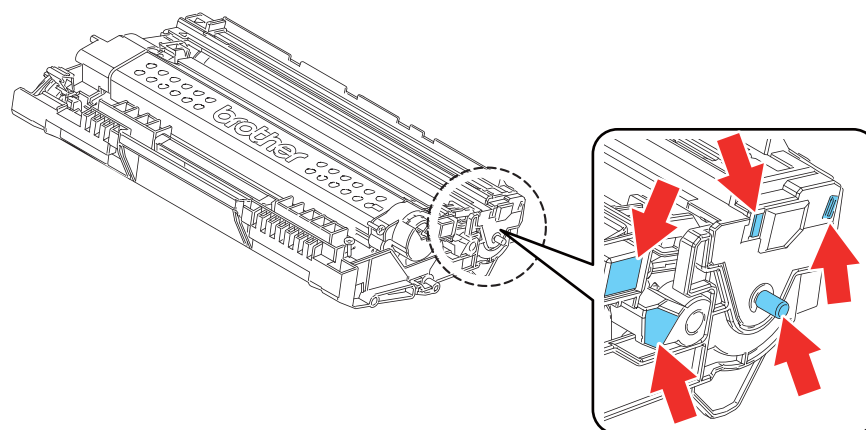


Fig. 2-16



■ **Electrodes location of the process unit**

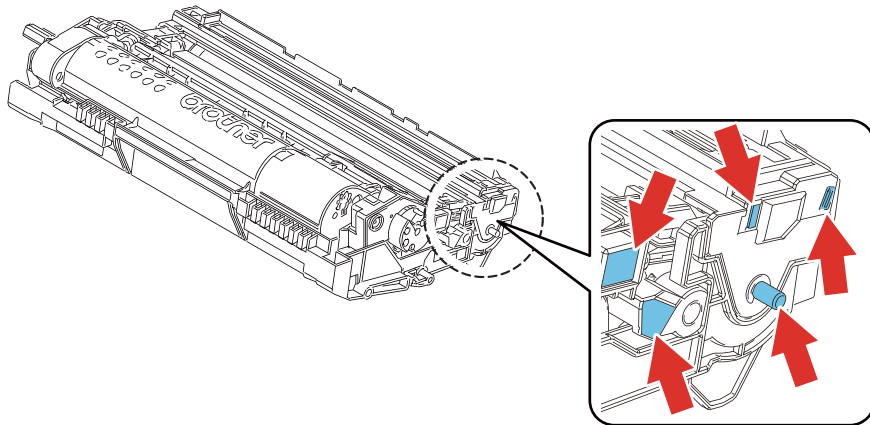


Fig. 2-17

■ **Faulty registration**



**<User Check>**

- Check whether appropriate paper type is selected on the driver.
- Install the latest main firmware.

Step	Cause	Remedy
1	Registration rear actuator coming off	Reattach the registration rear actuator.
2	Laser unit failure	Replace the laser unit.
3	Main PCB failure	Replace the main PCB ASSY.

■ Dark

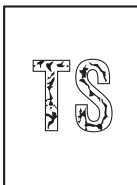


<User Check>

- Check the usage environment of the machine. Using the machine in hot-humid or cold-dry conditions can cause this problem.
- If a new toner cartridge has been detected, check that it was not replaced with another toner cartridge.
- Execute density adjustment from the control panel.
- Clean the corona wire of the drum unit.
- Replace the drum unit with a new one.
- Replace the toner cartridge with a new one.

Step	Cause	Remedy
1	Dirt on the electrodes of the drum unit and those of the machine	Clean the electrodes of the drum unit and those of the machine. (Refer to Fig. 2-12 (P2-56) and Fig. 2-13 (P2-56).)
2	Wrong adjusted value of the laser unit entered	Refer to "3.1 Entering Adjusted Value of Laser Unit" in Chapter 4, and enter the adjusted value of the laser unit correctly.
3	Dirt on the electrodes of the high-voltage power supply PCB	Clean the electrodes of the high-voltage power supply PCB.
4	Fuser unit failure	Replace the fuser unit.
5	High-voltage power supply PCB failure	Replace the high-voltage power supply PCB ASSY.
6	Laser unit failure	Replace the laser unit.
7	Main PCB failure	Replace the main PCB ASSY.

■ Poor fixing



<User Check>

- Check the usage environment of the machine. Using the machine in hot-humid or cold-dry conditions can cause this problem.
- Clean the corona wire of the drum unit.
- Replace the drum unit with a new one.
- Replace the toner cartridge with a new one.

Step	Cause	Remedy
1	Dirt on the electrodes of the drum unit and those of the machine	Clean the electrodes of the drum unit and those of the machine. (Refer to Fig. 2-12 (P2-56) and Fig. 2-13 (P2-56).)
2	Dirt on the electrodes of the toner cartridge and those of the machine	Clean the electrodes of the toner cartridge and those of the machine. (Refer to Fig. 2-12 (P2-56) and Fig. 2-16 (P2-84).)
3	Fuser unit failure	Replace the fuser unit.
4	High-voltage power supply PCB failure	Replace the high-voltage power supply PCB ASSY.
5	Low-voltage power supply PCB failure	Replace the low-voltage power supply PCB ASSY.
6	Laser unit failure	Replace the laser unit.
7	Main PCB failure	Replace the main PCB ASSY.

■ **Completely blank**



**<User Check>**

- Replace the drum unit with a new one.
- Replace the toner cartridge with a new one.
- Install the latest main firmware.

Step	Cause	Remedy
1	Connection failure of the laser unit flat cable	Reconnect the laser unit flat cable.
2	Laser unit attachment failure	Reattach the laser unit.
3	Laser unit flat cable failure	Replace the laser unit flat cable.
4	Dirt on the electrodes of the high-voltage power supply PCB and those of the machine	Clean the electrodes of the high-voltage power supply PCB and those of the machine.
5	Laser unit failure	Replace the laser unit.
6	Main PCB failure	Replace the main PCB ASSY.

■ **Image distortion**



Step	Cause	Remedy
1	Laser unit attachment failure	Reattach the laser unit.
2	Laser unit failure	Replace the laser unit.
3	Main PCB failure	Replace the main PCB ASSY.

■ All black



<User Check>

- Clean the corona wire of the drum unit.
- Replace the drum unit with a new one.

Step	Cause	Remedy
1	Dirt on the electrodes of the drum unit and those of the machine	Clean the electrodes of the drum unit and those of the machine. (Refer to Fig. 2-12 (P2-56) and Fig. 2-13 (P2-56).)
2	Laser unit flat cable failure	Replace the laser unit flat cable.
3	Dirt on the electrodes of the high-voltage power supply PCB and those of the machine	Clean the electrodes of the high-voltage power supply PCB and those of the machine.
4	High-voltage power supply PCB failure	Replace the high-voltage power supply PCB ASSY.
5	Laser unit failure	Replace the laser unit.
6	Main PCB failure	Replace the main PCB ASSY.

■ Dirt on back side of paper



<User Check>

- This problem may disappear after printing multiple sheets of paper.
- Replace the drum unit with a new one.

Step	Cause	Remedy
1	Dirt in the paper feed system	Wipe dirt off.
2	Dirt on the fuser unit	Replace the fuser unit.
3	High-voltage power supply PCB failure	Replace the high-voltage power supply PCB ASSY.

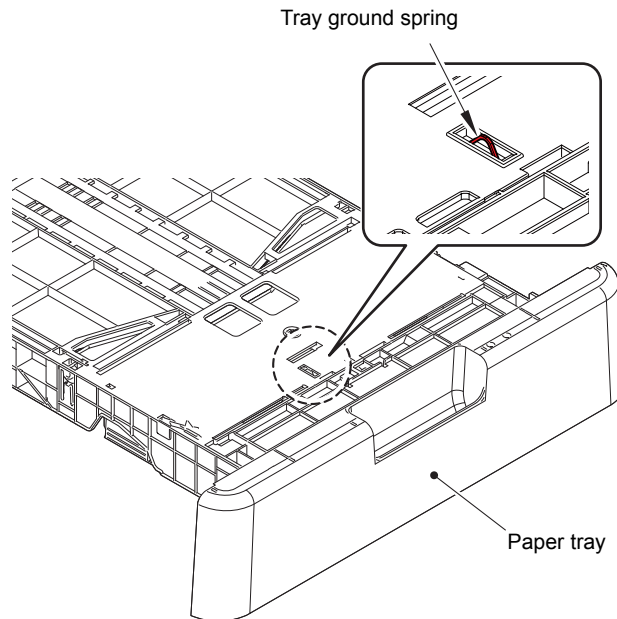
■ Vertical streaks



<User Check>

- Clean the corona wire of the drum unit.
- Return the corona wire cleaning tab to the “▲” position.
- This problem may disappear after printing multiple sheets of paper.
- Refer to <How to clean the drum unit> to remove the dirt from the exposure drum using a cotton applicator.
- Replace the drum unit with a new one.
- Replace the toner cartridge with a new one.

Step	Cause	Remedy
1	Dirt in the paper feed system	Wipe dirt off.
2	A ground wire or ground plate installation failure (Grounding is not performed correctly.)	Retighten the screws of each ground wire or ground plate. Repair the bend of the tray ground spring of the paper tray. (Refer to the figure below.)
3	Dirt on the exposure drum	Perform drum cleaning. (Refer to “2.1 Drum Cleaning” in Chapter 5.)
4	Dirt on the cleaner pinch roller of the fuser cover	Replace the cleaner pinch roller S ASSY.
5	Dirt on the fuser unit	Replace the fuser unit.
6	Laser unit failure	Replace the laser unit.



<Bottom of paper tray>

Fig. 2-18

■ **Horizontal stripes**



**<User Check>**

- This problem may disappear after printing multiple sheets of paper.
- Refer to **<How to clean the drum unit>** to remove the dirt from the exposure drum using a cotton applicator.
- Replace the drum unit with a new one.
- Replace the toner cartridge with a new one.

Step	Cause	Remedy
1	Dirty charge electrodes	Clean the electrodes of the drum unit and those of the machine. (Refer to <b>Fig. 2-13 (P2-56)</b> and <b>Fig. 2-12 (P2-56)</b> .)
2	Dirt on the exposure drum	Perform drum cleaning. (Refer to <b>"2.1 Drum Cleaning" in Chapter 5</b> .)
3	A ground wire or ground plate installation failure (Grounding is not performed correctly.)	Retighten the screws of each ground wire or ground plate. Repair the bend of the tray ground spring of the paper tray. (Refer to <b>Fig. 2-18 (P2-89)</b> .)
4	Scratch or dirt on the fuser unit	Replace the fuser unit.
5	High-voltage power supply PCB failure	Replace the high-voltage power supply PCB ASSY.

■ **White vertical streaks on image**



**<User Check>**

- Check that there is no dust on the toner cartridge.
- Refer to **<How to clean the drum unit>** to remove the dirt from the exposure drum using a cotton applicator.
- Replace the drum unit with a new one.
- Replace the toner cartridge with a new one.

Step	Cause	Remedy
1	Dirt on the exposure drum	Perform drum cleaning. (Refer to <b>"2.1 Drum Cleaning" in Chapter 5</b> .)
2	Laser unit failure	Replace the laser unit.

■ **White horizontal stripes on image**



**<User Check>**

- This problem may disappear after printing multiple sheets of paper.
- Replace the drum unit with a new one.
- Replace the toner cartridge with a new one.

Step	Cause	Remedy
1	Dirty charge electrodes	Clean the electrodes of the drum unit and those of the machine. (Refer to Fig. 2-13 (P2-56) and Fig. 2-12 (P2-56).)
2	Dirt on the exposure drum	Perform drum cleaning. (Refer to “2.1 Drum Cleaning” in Chapter 5.)
3	Scratch or dirt on the fuser unit	Replace the fuser unit.
4	High-voltage power supply PCB failure	Replace the high-voltage power supply PCB ASSY.

■ **Faint print**

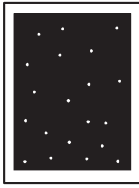


**<User Check>**

- Check that the machine is positioned on a level surface.
- Replace the drum unit with a new one.
- Replace the toner cartridge with a new one.

Step	Cause	Remedy
1	Laser unit failure	Replace the laser unit.
2	Fuser unit failure	Replace the fuser unit.
3	Main PCB failure	Replace the main PCB ASSY.

■ **White spots on image**



**<User Check>**

- Check that the fan is not clogged.
- Refer to **<How to clean the drum unit>** to remove the dirt from the exposure drum using a cotton applicator.
- Replace the drum unit with a new one.
- Replace the toner cartridge with a new one.

Step	Cause	Remedy
1	Dirt on the paper dust cleaning roller of the paper tray	Refer to the <b>Fig. 2-14 (P2-73)</b> to clean the paper dust cleaning roller.
2	Dirt on the exposure drum	Perform drum cleaning. (Refer to <b>"2.1 Drum Cleaning"</b> in Chapter 5.)
3	Clogged filter	Clean the filter.
4	Scratch or dirt on the fuser unit	Replace the fuser unit.
5	High-voltage power supply PCB failure	Replace the high-voltage power supply PCB ASSY.

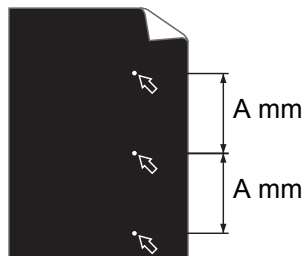
**Note:**

Image defects which appear periodically may be caused by failure of rollers. Refer to the table below and determine the cause based on the pitch at which defects appear on the image.

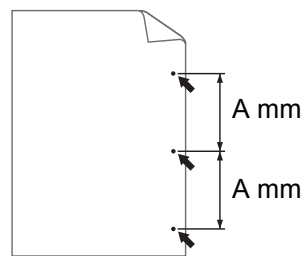
**<itches on images caused by rollers>**

Part name	The pitch which appears in the image
Develop roller	26.5 mm
Exposure drum	94.5 mm
Heat roller of the fuser unit	78.5 mm
Pressure roller of the fuser unit	78.5 mm

**< Examples of image distortion >**



White dots repeat in A mm distance on the black page with printed images.



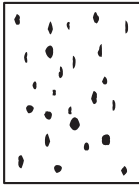
Black dots repeat in A mm distance on the page.

**Fig. 2-19**

Refer to the **<itches on images caused by rollers>** table above for what represents the value A.



■ Spots or dirt



<User Check>

- Check if damp paper is used.
- Refer to <How to clean the drum unit> to remove the dirt from the exposure drum using a cotton applicator.
- Replace the drum unit with a new one.
- Replace the toner cartridge with a new one.

Step	Cause	Remedy
1	Dirt on the paper dust cleaning roller of the paper tray	Refer to the Fig. 2-14 (P2-73) to clean the paper dust cleaning roller.
2	Dirt on the exposure drum	Perform drum cleaning. (Refer to "2.1 Drum Cleaning" in Chapter 5.)
3	Clogged filter	Clean the filter.
4	Scratch or dirt on the fuser unit	Replace the fuser unit.
5	High-voltage power supply PCB failure	Replace the high-voltage power supply PCB ASSY.

**Note:**

Image defects which appear periodically may be caused by failure of rollers. Refer to <Pitches on images caused by rollers> and determine the cause based on the pitch at which defects appear on the image.

■ **Band**



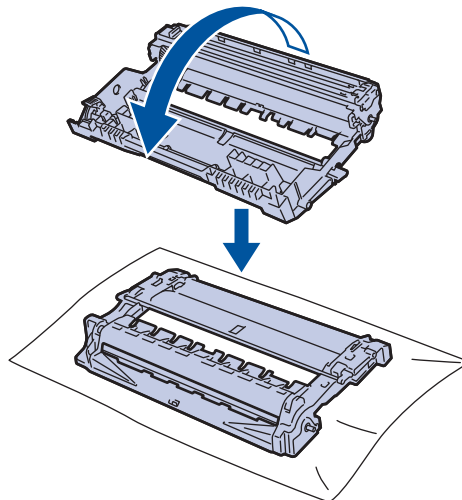
**<User Check>**

- Clean the corona wire of the drum unit.
- Clean the corona wire by sliding the green tab of the drum unit to the left end.
- This problem may disappear after printing multiple sheets of paper.
- Refer to **<How to clean the drum unit>** to remove the dirt from the exposure drum using a cotton applicator.
- Replace the drum unit with a new one.
- Replace the toner cartridge with a new one.

Step	Cause	Remedy
1	A ground wire or ground plate installation failure (Grounding is not performed correctly.)	Retighten the screws of each ground wire or ground plate. Repair the bend of the tray ground spring of the paper tray. (Refer to <b>Fig. 2-18 (P2-89)</b> .)
2	Dirt on the exposure drum	Perform drum cleaning. (Refer to <b>"2.1 Drum Cleaning" in Chapter 5</b> .)
3	Laser unit failure	Replace the laser unit.

**<How to clean the drum unit (the shape of the drum is different from the actual one)>**

- (1) Remove the toner cartridge from the drum unit. Turn the drum unit as shown in the illustration. Make sure that the drum unit gear is on the left side.



**Fig. 2-20**

- (2) Use the numbered markers next to the drum roller to find the mark on the drum. For example, a dot in column 2 on the check sheet means that there is a mark in drum region "2".

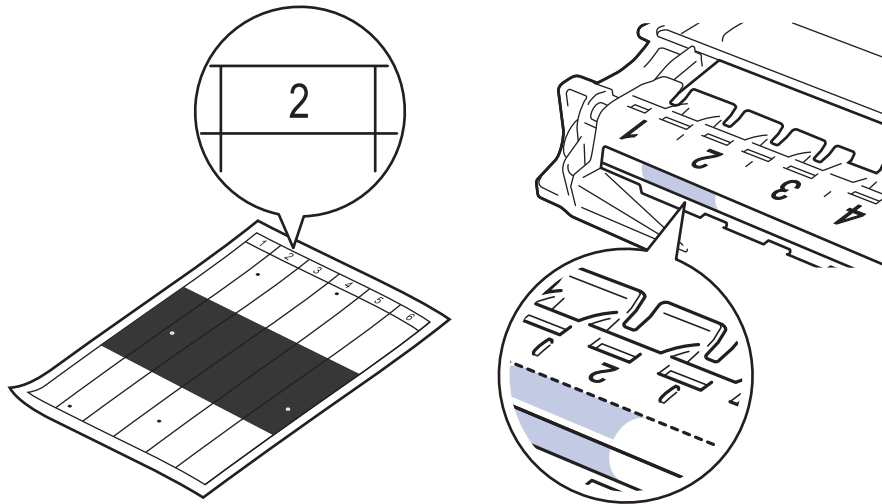


Fig. 2-21

- (3) Turn the edge of the drum unit towards you while looking at the drum surface to find the mark.

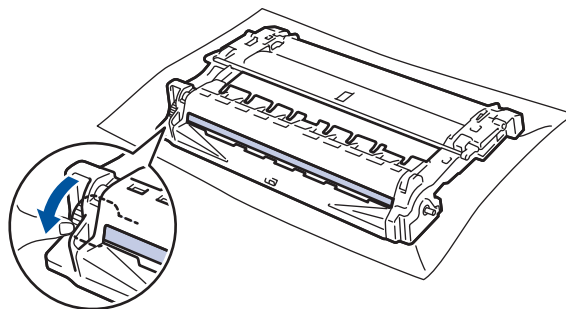


Fig. 2-22

- (4) Wipe the surface of the drum gently with a dry cotton swab until the mark or foreign material on the surface comes off.

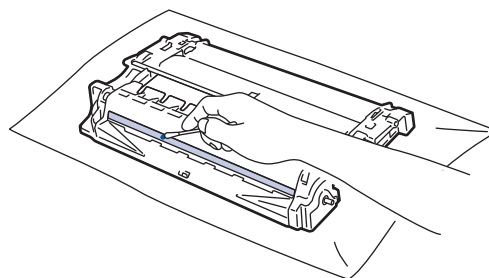


Fig. 2-23

**Note:**

Do not clean the exposure drum surface with anything sharp like a ball pointed pen.

■ **Downward fogging of solid color**

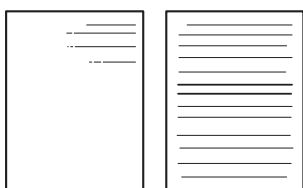


**<User Check>**

- Replace the toner cartridge with a new one.

Step	Cause	Remedy
1	High-voltage power supply PCB failure	Replace the high-voltage power supply PCB ASSY.
2	Main PCB failure	Replace the main PCB ASSY.

■ **Horizontal lines**



**<User Check>**

- This problem may disappear after printing multiple sheets of paper.
- Refer to [<How to clean the drum unit>](#) to remove the dirt from the exposure drum using a cotton applicator.
- Replace the drum unit with a new one.
- Replace the toner cartridge with a new one.

Step	Cause	Remedy
1	Dirty charge electrodes	Clean the electrodes of the drum unit and those of the machine. (Refer to <a href="#">Fig. 2-13 (P2-56)</a> and <a href="#">Fig. 2-12 (P2-56)</a> .)
2	Dirt on the exposure drum	Perform drum cleaning. (Refer to <a href="#">“2.1 Drum Cleaning” in Chapter 5.</a> )
3	Scratch or dirt on the fuser unit	Replace the fuser unit.
4	High-voltage power supply PCB failure	Replace the high-voltage power supply PCB ASSY.

■ Ghost



<User Check>

- Check the usage environment of the machine. Using the machine in hot-humid or cold-dry conditions can cause this problem.
- Check whether appropriate paper type is selected on the driver.
- Select “Improve Toner Fixing” in the driver.
- Replace the drum unit with a new one.
- Replace the toner cartridge with a new one.

Step	Cause	Remedy
1	Scratch or dirt on the fuser unit, or conductive leaf spring deformation	Replace the fuser unit.
2	High-voltage power supply PCB failure	Replace the high-voltage power supply PCB ASSY.

■ Fogging



<User Check>

- Check the usage environment of the machine. Using the machine in hot-humid or cold-dry conditions can cause this problem.
- Check if the acid paper is not used.
- This problem may disappear after printing multiple sheets of paper.
- Replace the toner cartridge with a new one.
- Replace the drum unit with a new one.

Step	Cause	Remedy
1	Dirt on the electrodes of the toner cartridge and those of the machine	Clean the electrodes of the toner cartridge. (Refer to Fig. 2-16 (P2-84).)
2	New toner sensor PCB failure	Replace the new toner sensor PCB ASSY.
3	High-voltage power supply PCB failure	Replace the high-voltage power supply PCB ASSY.
4	Main PCB failure	Replace the main PCB ASSY.

**Note:**

This problem tends to occur when the life of the drum unit or toner cartridge is expiring.

## 4.4 Troubleshooting for Software Problems

The end user can solve problems pertaining to software, for instance, print cannot be made from a computer although test print and printer setting print can be made from the machine, by following the User Check items. If the same problem occurs again, follow each procedure in the order of the number described in the Step column in the tables below.

### 4.4.1 Unable to receive data

#### <User Check>

- Check that the USB cable or LAN cable is not damaged.
- When using an interface switch, check that the correct machine is selected.
- Check the relevant section in the online User's Guide.
- Check the driver settings.
- Reset the machine to the default settings. (Refer to the online User's Guide.)

Step	Cause	Remedy
1	Machine connection	For Macintosh, check the Product ID*. When it is wrong, update the firmware.
2	Main PCB failure	Replace the main PCB ASSY.

\* Follow the procedures below to verify the product ID in Macintosh.

- (1) Select [About This Mac] from the [Apple] menu.
- (2) Click the [More Info...] in the [About This Mac] dialog box.
- (3) Select [USB] under the [Hardware] in [Contents] on the left side.
- (4) Select the machine [MFC-XXXX] from [USB Device Tree].
- (5) Check [Product ID] in [MFC-XXXX].

#### ■ Product ID (Hexadecimal)

DCP-7090	0417h	DCP-L2537DW	0422h	MFC-L2710DW	0434h
DCP-7095D	0418h	DCP-L2550DN	0423h	MFC-L2712DN	0433h
DCP-7190DN	0419h	DCP-L2550DW	0424h	MFC-L2712DW	0434h
DCP-7195DW	041Ah	DCP-L2551DN	0425h	MFC-L2713DW	0435h
DCP-B7500D	041Bh	DCP-L2551DW	0424h	MFC-L2715D	0436h
DCP-B7520DW	041Ch	DCP-L2552DN	0423h	MFC-L2715DW	043Ch
DCP-B7530DN	041Dh	HL-L2390DW	0428h	MFC-L2716D	0436h
DCP-B7535DW	041Eh	HL-L2395DW	0429h	MFC-L2716DW	043Ch
DCP-L2510D	041Fh	MFC-7390	042Ah	MFC-L2717DW	0437h
DCP-L2511D	041Fh	MFC-7490D	042Bh	MFC-L2730DW	0439h
DCP-L2512D	041Fh	MFC-7890DN	042Ch	MFC-L2732DW	0439h
DCP-L2530DW	0420h	MFC-7895DW	042Dh	MFC-L2750DW	043Ah
DCP-L2531DW	0420h	MFC-B7700D	042Eh	MFC-L2750DWXL	043Ah
DCP-L2532DW	0420h	MFC-B7715DW	0430h	MFC-L2751DW	043Ah
DCP-L2535D	0421h	MFC-B7720DN	0431h	MFC-L2752DW	043Ah
DCP-L2535DW	043Dh	MFC-L2690DW	0432h	MFC-L2770DW	043Bh
DCP-L2536D	0421h	MFC-L2710DN	0433h	MFC-L2771DW	043Bh

## 4.5 Troubleshooting for Network Problems

### 4.5.1 Cannot make a print through network connection

#### <User Check>

- Check the relevant section in the Network Setting Guide.
- Check the network connection.
- Reset the network. (Refer to the online User's Guide.)
- Check the LAN cable.
- Check that the Wired and WLAN I/F are not disabled.
- Check that the Wi-Fi Direct is not disabled.

Step	Cause	Remedy
1	Connection failure of the wireless LAN PCB connector	Reconnect the wireless LAN PCB connector.
2	Wireless LAN PCB failure	Replace the wireless LAN PCB.
3	LAN terminal pin deformation Main PCB failure	Replace the main PCB ASSY.

### 4.5.2 Cannot connect to access point

#### <User Check>

- Check the wireless LAN settings.
- Check the access point settings.
- Change the machine installation location.
- Set the access point manually.

Step	Cause	Remedy
1	Wireless LAN PCB failure	Replace the wireless LAN PCB.
2	Main PCB failure	Replace the main PCB ASSY.

## 4.6 Troubleshooting for Control Panel Problems

### 4.6.1 Nothing is displayed on the LCD

#### <User Check>

- Turn the power switch OFF and then back ON again.
- Unplug the AC cord and then plug it again.

Step	Cause	Remedy
1	Connection failure of the panel flat cable	Reconnect the panel flat cable.
2	Connection failure of the low-voltage power supply harness	Reconnect the low-voltage power supply harness.
3	Connection failure of the LCD flat cable	Reconnect the LCD flat cable.
4	AC cord failure	Replace the AC cord.
5	Panel flat cable failure	Replace the panel flat cable.
6	LCD failure	Replace the panel unit.
7	Panel PCB ASSY failure	Replace the panel PCB ASSY.
8	Low-voltage power supply PCB failure	Replace the low-voltage power supply PCB ASSY.
9	Main PCB failure	Replace the main PCB ASSY.

### 4.6.2 Nothing is displayed on the LED

#### <User Check>

- Turn the power switch OFF and then back ON again.

Step	Cause	Remedy
1	Connection failure of the key PCB flat cable	Reconnect the key PCB flat cable.
2	Panel flat cable failure	Replace the panel flat cable.
3	Key PCB failure	Replace the key PCB ASSY.
4	Main PCB failure	Replace the main PCB ASSY.

### 4.6.3 Unable to perform panel operation

#### <User Check>

- Turn the power switch OFF and then back ON again.

Step	Cause	Remedy
1	Connection failure of the panel flat cable	Reconnect the panel flat cable.
2	Connection failure of the touch panel flat cable	Reconnect the touch panel flat cable.
3	Connection failure of the key PCB flat cable	Reconnect the key PCB flat cable.
4	Panel PCB failure	Replace the panel PCB ASSY.
5	Key PCB failure	Replace the key PCB ASSY.
6	Touch panel ASSY failure	Replace the panel unit.
7	Main PCB failure	Replace the main PCB ASSY.



## 4.7 Troubleshooting for Toner Cartridge and Drum Unit Problems

### 4.7.1 New toner not detected

#### <User Check>

- Be sure to set a new toner cartridge(or box).
- Check that the genuine toner cartridge(or box) is set.

Step	Cause	Remedy
1	New toner actuator coming off	Reattach the new toner actuator.
2	Connection failure of the new toner sensor PCB harness (Models without toner box)	Reconnect the new toner sensor PCB harness.
3	Connection failure of the new toner box sensor PCB harness (Models with toner box)	Reconnect the new toner box sensor PCB harness.
4	Connection failure of the toner box relay PCB harness (Models with toner box)	Reconnect the toner box relay PCB harness.
5	New toner sensor PCB failure (Models without toner box)	Replace the new toner sensor PCB ASSY.
6	New toner box sensor PCB failure (Models with toner box)	Replace the new toner box sensor PCB ASSY.
7	Toner box relay PCB failure (Models with toner box)	Replace the toner box relay PCB ASSY.
8	High-voltage power supply PCB failure	Replace the high-voltage power supply PCB ASSY.
9	Main PCB failure	Replace the main PCB ASSY.

### 4.7.2 Toner cartridge not detected

#### <User Check>

- Re-assemble the toner cartridge(or box).
- Replace the toner cartridge(or box) with a new one.

Step	Cause	Remedy
1	New toner sensor PCB failure (Models without toner box)	Replace the new toner sensor PCB ASSY.
2	New toner box sensor PCB failure (Models with toner box)	Replace the new toner box sensor PCB ASSY.
3	Main PCB failure	Replace the main PCB ASSY.

### 4.7.3 Toner replacement message displayed on LCD is not cleared

#### <User Check>

- Be sure to set a new toner cartridge(or box).
- Check that the genuine toner cartridge(or box) is set.

Step	Cause	Remedy
1	New toner actuator coming off	Reattach the new toner actuator.
2	Connection failure of the new toner sensor PCB harness (Models without toner box)	Reconnect the new toner sensor PCB harness.
3	Connection failure of the new toner box sensor PCB harness (Models with toner box)	Reconnect the new toner box sensor PCB harness.
4	Connection failure of the toner box relay PCB harness (Models with toner box)	Reconnect the toner box relay PCB harness.
5	New toner sensor PCB failure (Models without toner box)	Replace the new toner sensor PCB ASSY.
6	New toner box sensor PCB failure (Models with toner box)	Replace the new toner box sensor PCB ASSY.
7	Toner box relay PCB failure (Models with toner box)	Replace the toner box relay PCB ASSY.
8	High-voltage power supply PCB failure	Replace the high-voltage power supply PCB ASSY.
9	Main PCB failure	Replace the main PCB ASSY.

### 4.7.4 Drum error

#### <User Check>

- Clean the corona wire of the drum unit.
- Replace the drum unit with a new one.

Step	Cause	Remedy
1	Dirt on the electrodes of the drum unit and those of the machine	Clean the electrodes of the drum unit and those of the machine. (Refer to <a href="#">Fig. 2-12 (P2-56)</a> and <a href="#">Fig. 2-13 (P2-56)</a> .)
2	Dirt on the electrodes of the high-voltage power supply PCB and those of the machine	Clean the electrodes of the high-voltage power supply PCB and those of the machine.
3	High-voltage power supply PCB failure	Replace the high-voltage power supply PCB ASSY.
4	Main PCB failure	Replace the main PCB ASSY.

### 4.7.5 Drum replacement message displayed on LCD is not cleared

#### <User Check>

- Reset the drum counter according to the manual.

Step	Cause	Remedy
1	Main PCB failure	Replace the main PCB ASSY.

## 4.8 Troubleshooting for Fuser Unit Problems

### 4.8.1 Fuser unit failure

Step	Cause	Remedy
1	Connection failure of the center thermistor harness	Reconnect the center thermistor harness.
2	Connection failure of the side thermistor harness	Reconnect the side thermistor harness.
3	Connection failure of the heater harness	Reconnect the heater harness.
4	Connection failure of the eject sensor PCB harness	Reconnect the eject sensor PCB harness.
5	Eject sensor PCB failure	Replace the eject sensor PCB ASSY.
6	Low-voltage power supply PCB failure	Replace the low-voltage power supply PCB ASSY.
7	Fuser unit failure	Replace the fuser unit.
8	Main PCB failure	Replace the main PCB ASSY.

**Note:**

- Turn the power switch OFF and then ON again. Leave the machine for 15 minutes. This problem may then be cleared.
- The machine may recover from the error, when the test printing of the maintenance mode for service personnel is started. However, conducting this operation while the heater has not yet cooled may cause the fuser unit to melt. Be careful.

## 4.9 Troubleshooting for Laser Unit Problems

### 4.9.1 Laser unit failure

**<User Check>**

- Turn ON the power switch, then open the front cover and the back cover. Leave the machine for a while to remove condensation.

Step	Cause	Remedy
1	Laser unit attachment failure	Reattach the laser unit.
2	Connection failure of the laser unit flat cable	Reconnect the laser unit flat cable.
3	Connection failure of the polygon motor harness	Reconnect the polygon motor harness.
4	Laser unit failure	Replace the laser unit.
5	Main PCB failure	Replace the main PCB ASSY.

## 4.10 Troubleshooting for PCB Problems

### 4.10.1 Main PCB failure

#### <User Check>

- Turn the power switch OFF and then back ON again.
- Install the latest main firmware.
- Check the print limit ID.
- Check that the print data is not damaged.

Step	Cause	Remedy
1	Main PCB failure	Replace the main PCB ASSY.

### 4.10.2 Full memory

#### <User Check>

- Print the accumulated data.
- Reduce the amount or resolution of the data.

Step	Cause	Remedy
1	Main PCB failure	Replace the main PCB ASSY.

## 4.11 Troubleshooting for Document Feeding Problems

### 4.11.1 No document is fed

#### <User Check>

- Set the document properly and check that the display on the LCD changes.
- Check that the number of paper set has not exceeded the upper limit in the document tray.
- Check that the ADF cover is closed correctly.

Step	Cause	Remedy
1	Document detection actuator coming off	Reattach the document detection actuator.
2	Connection failure of the ADF motor harness	Reconnect the ADF motor harness.
3	Boss to push the ADF cover sensor of the ADF cover	Replace the ADF cover ASSY.
4	Document separate roller failure	Replace the document separate roller ASSY.
5	Damaged ADF drive gear	Replace the ADF unit.
6	Main PCB failure	Replace the main PCB ASSY.

### 4.11.2 Multiple documents are fed

#### <User Check>

- Check that the thickness of the document is 64 to 105 g/m<sup>2</sup>.
- Check that the number of paper set has not exceeded the upper limit in the document tray.

Step	Cause	Remedy
1	Abrasion of ADF separation pad	Replace the ADF separation pad.

### 4.11.3 Document jam

#### ■ Paper jam in the ADF cover

##### <User Check>

- Check that the thickness of the document is 64 to 105 g/m<sup>2</sup>.
- Check that the paper used for the document is not shorter than 147.3 mm.
- Check that the ADF cover is closed correctly.
- Check that the number of paper set has not exceeded the upper limit in the document tray.

Step	Cause	Remedy
1	Foreign object inside the area around ADF cover	Remove the foreign object.
2	Document pinch roller 1 coming off	Reattach the document pinch roller 1.
3	Damaged ADF drive gear	Replace the ADF unit.
4	Main PCB failure	Replace the main PCB ASSY.

#### ■ Paper jam in the ADF

##### <User Check>

- Check that the thickness of the document is 64 to 105 g/m<sup>2</sup>.
- Check whether the document is smaller or larger than the specifications.
- Check whether the document is wet or wrinkled.
- Check that the document guide is adjusted to suit the document size.

Step	Cause	Remedy
1	Foreign object inside the ADF	Remove the foreign object.
2	Document scanning position actuator coming off	Reattach the document scanning position actuator.
3	Document pinch roller 2 coming off	Reattach the document pinch roller 2.
4	Connection failure of the document scanning position sensor harness	Check the connection of the document scanning position sensor harness, and reconnect it if necessary.
5	Second side document hold coming off	Reattach the second side document hold.
6	First side document hold coming off	Reattach the first side document hold.
7	Fed at an angle and jammed due to abrasion of document separate roller	Replace the document separate roller ASSY.
8	Document scanning position sensor failure	Replace the ADF unit.
9	Main PCB failure	Replace the main PCB ASSY.

■ **Paper jam in the paper eject section of the ADF**

**<User Check>**

- Check that the thickness of the document is 64 to 105 g/m<sup>2</sup>.

Step	Cause	Remedy
1	Foreign object in the ADF document eject path	Remove the foreign object.
2	Document pinch roller coming off	Reattach the document pinch roller.
3	Abrasion of document eject roller	Replace the ADF unit.
4	Main PCB failure	Replace the main PCB ASSY.

**4.11.4 Document becomes wrinkled**

**<User Check>**

- Check that the document is not curled.
- Check that the document guide is adjusted to suit the document size.

Step	Cause	Remedy
1	Abrasion of document separate roller	Replace the document separate roller ASSY.
2	Abrasion of document feed roller	Replace the ADF unit.

**4.11.5 Document size is not detected correctly**

**<User Check>**

- Check that the document size is within the standard.

Step	Cause	Remedy
1	Document scanning position actuator caught in some sections of the machine	Reattach the document scanning position actuator.
2	ADF motor failure	Replace the ADF unit.
3	Main PCB failure	Replace the main PCB ASSY.

## 4.12 Troubleshooting for Scanning Image Defect

### 4.12.1 Defect examples

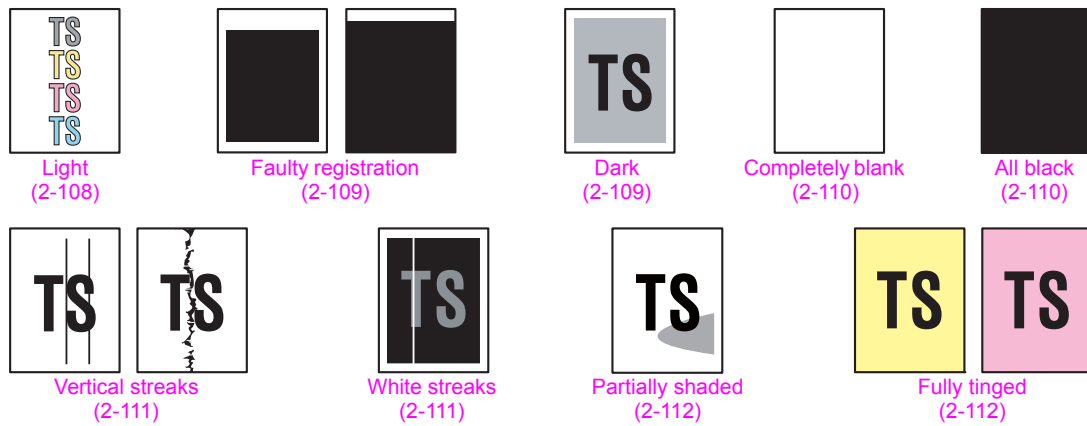
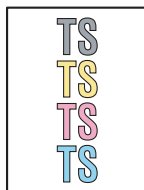


Fig. 2-24

### 4.12.2 Troubleshooting according to image defect

#### ■ Light



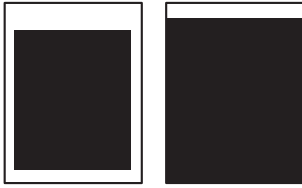
#### <User Check>

- Check that the contrast setting is not too light.
- Clean the scanner glass or first side/second side scanner glass strip.
- Clean the document hold.

Step	Cause	Remedy
1	Incorrect white level correction data	Execute "Acquire white level data (Function code 55)".
2	First or second side CIS unit failure	Replace the first or second side CIS unit.
3	Main PCB failure	Replace the main PCB ASSY.



■ **Faulty registration**



- First side (Document scanner unit)

Step	Cause	Remedy
1	Deviation of the scanning start position	Execute "Fine adjustment of scan start position (Function code 54)".
2	Document scanning position actuator caught in some sections of the machine	Reattach the document scanning position actuator.

- Second side (ADF unit)

Step	Cause	Remedy
1	Deviation of the scanning start position	Execute "Fine adjustment of scan start position (Function code 54)".
2	Document scanning position actuator caught in some sections of the machine	Reattach the document scanning position actuator.

■ **Dark**



**<User Check>**

- Check that the contrast setting is not too dark.
- Clean the document hold.

Step	Cause	Remedy
1	Incorrect white level correction data	Execute "Acquire white level data (Function code 55)".
2	First or second side CIS unit failure	Replace the first or second side CIS unit.
3	Main PCB failure	Replace the main PCB ASSY.

■ **Completely blank**



**<User Check>**

- Check that the document is not reversed.

Step	Cause	Remedy
1	Incorrect white level correction data	Execute “Acquire white level data (Function code 55)”.
2	First or second side CIS flat cable failure	Replace the first or second side CIS flat cable.
3	First or second side CIS unit failure	Replace the first or second side CIS unit.
4	Main PCB failure	Replace the main PCB ASSY.

■ **All black**



**<User Check>**

- Install all the latest firmwares.

Step	Cause	Remedy
1	Incorrect white level correction data	Execute “Acquire white level data (Function code 55)”.
2	First or second side CIS flat cable failure	Replace the first or second side CIS flat cable.
3	First or second side CIS unit failure	Replace the first or second side CIS unit.
4	Main PCB failure	Replace the main PCB ASSY.

■ **Vertical streaks**



**<User Check>**

- Clean the scanner glass or first side/second side scanner glass strip.
- Clean the document hold.

Step	Cause	Remedy
1	Dirt inside of scanner glass	Clean the inside of the scanner glass.
2	Dirt inside of first side/second side scanner glass strip	Clean the inside of the first side/second side scanner glass strip.
3	First or second side CIS unit failure	Replace the first or second side CIS unit.
4	Scratch on scanner glass	Replace the document scanner unit.
5	Scratch on second side scanner glass strip	Replace the ADF unit.

■ **White streaks**



**<User Check>**

- Clean the scanner glass or first side/second side scanner glass strip.
- Clean the document hold.

Step	Cause	Remedy
1	Dirt inside of scanner glass	Clean the inside of the scanner glass.
2	Dirt inside of first side/second side scanner glass strip	Clean the inside of the first side/second side scanner glass strip.
3	First or second side CIS unit failure	Replace the first or second side CIS unit.
4	Scratch on scanner glass	Replace the document scanner unit.
5	Scratch on second side scanner glass strip	Replace the ADF unit.

■ Partially shaded



<User Check>

- Clean the scanner glass.

Step	Cause	Remedy
1	Dirt inside of scanner glass	Clean the inside of scanner glass.
2	Deformed document sponge	Replace the document scanner unit.

■ Fully tinged



<User Check>

- Clean the scanner glass or first side/second side scanner glass strip.

Step	Cause	Remedy
1	Incorrect white level correction data	Execute "Acquire white level data (Function code 55)".
2	First or second side CIS unit failure	Replace the first or second side CIS unit.
3	Main PCB failure	Replace the main PCB ASSY.

## 4.13 Troubleshooting for FAX/Phone Problems

### 4.13.1 Fax cannot be sent

#### <User Check>

- Check that the line cord is inserted into the socket correctly.
- Check that the dial function setting (tone/pulse) is correct.
- Check that the fax document is set in the ADF correctly.
- Check that the number to be dialed is saved correctly in the telephone directory.
- Check that the receiver's machine works normally or the function you want to perform is equipped with the receiver's machine.
- Move the machine to the other place to check whether there is any noise source near the machine.
- Replace the telephone line.

Step	Cause	Remedy
1	Connection failure of the modem flat cable	Reconnect the modem flat cable.
2	Connection failure of the CIS flat cable	Reconnect the CIS flat cable.
3	Connection failure of the panel flat cable	Reconnect the panel flat cable.
4	Connection failure of the touch panel flat cable	Reconnect the touch panel flat cable.
5	Connection failure of the key PCB flat cable	Reconnect the key PCB flat cable.
6	Connection failure of the ADF document detection sensor PCB harness	Reconnect the ADF document detection sensor PCB harness.
7	Document detection actuator coming off	Reattach the document detection actuator.
8	First or second side CIS flat cable failure	Replace the first or second side CIS flat cable.
9	First or second side CIS unit failure	Replace the first or second side CIS unit.
10	ADF drive gear failure	Replace the ADF unit.
11	Document scanner unit failure	Replace the document scanner unit.
12	Panel PCB failure	Replace the panel PCB ASSY.
13	Key PCB failure	Replace the key PCB ASSY.
14	Modem PCB failure	Replace the modem PCB ASSY.
15	Main PCB failure	Replace the main PCB ASSY.

### 4.13.2 Fax cannot be received

#### <User Check>

- Check that the line cord is inserted into the socket correctly.
- Check that the receiving mode setting is correct.
- Check that the receiver's machine works normally or the function you want to perform is equipped with the receiver's machine.
- Move the machine to the other place to check whether there is any noise source near the machine.
- Replace the telephone line.

Step	Cause	Remedy
1	Connection failure of the modem flat cable	Reconnect the modem flat cable.
2	Modem PCB failure	Replace the modem PCB ASSY.
3	Main PCB failure	Replace the main PCB ASSY.

### 4.13.3 Communication error occurs

#### <User Check>

- Check whether there is any noise source near the machine.
- Replace the telephone line.

Step	Cause	Remedy
1	Connection failure of the modem flat cable	Reconnect the modem flat cable.
2	Modem PCB failure	Replace the modem PCB ASSY.
3	Main PCB failure	Replace the main PCB ASSY.

### 4.13.4 Receive buffer full during receiving into memory

#### <User Check>

- Print the print data stored in the memory.
- Divide the print data and print it.

Step	Cause	Remedy
1	Main PCB failure	Replace the main PCB ASSY.

## 4.14 Troubleshooting for Other Problems

### 4.14.1 Cannot make print

#### <User Check>


- Turn the power switch OFF and then back ON again.
- Check that the USB cable is connected to the host correctly.
- Check that the LAN cable is connected to the host correctly.
- Replace the USB cable.
- Replace the LAN cable.
- Check that the maximum printable page number has not been exceeded.
- Check that the PC Print is not forbidden.
- Check the print limit ID.
- Check the network connection.
- Check the relevant section in the Network Setting Guide.
- Check that the print data is not damaged.
- Install the latest main firmware.
- Match the document size with the one specified in the driver.
- Check that the printer driver used is the correct driver.
- Set the paper of the specified size in each tray again.
- Close the paper tray properly.

Step	Cause	Remedy
1	Connection failure of the wireless LAN connector	Reconnect the wireless LAN connector.
2	Connection failure of the MP paper empty sensor PCB harness	Reconnect the MP paper empty sensor PCB harness.
3	Connection failure of the T1 paper feed sensor harness (non paper empty sensor models only)	Reconnect the T1 paper feed sensor harness.
4	Connection failure of the T1 paper empty/paper feed sensor harness (paper empty sensor models only)	Reconnect the T1 paper empty/paper feed sensor harness.
5	Connection failure of the T1 clutch harness	Reconnect the T1 clutch harness.
6	T1/MP paper empty actuator caught in some sections of the machine (paper empty sensor models only)	Reattach the appropriate T1/MP paper empty actuator.
7	T1 paper feed actuator caught in some sections of the machine (non paper empty sensor models only)	Reattach the T1 paper feed actuator.
8	T1 paper feed sensor PCB failure (non paper empty sensor models only)	Replace the T1 paper feed sensor PCB ASSY.
9	T1 paper empty/paper feed sensor PCB failure (paper empty sensor models only)	Replace the T1 paper empty/paper feed sensor PCB ASSY.
10	Wireless LAN PCB failure	Replace the wireless LAN PCB.
11	Main PCB failure	Replace the main PCB ASSY.

## 4.14.2 Cannot update firmware

### <User Check>

- Make sure that there is no other function running.
- Turn the power switch OFF and then back ON again.

Step	Cause	Remedy
1	Firmware version does not match	Reinstall the latest sub firmware and main firmware in this order.
2	In case of update failure by interruption, the firmware might not correctly written in the ROM	Update the firmware again by the following procedure.* 1) Turn OFF the machine. 2) For touch panel models, press and hold the  and turn the machine ON. For non-touch panel with ten key models, press and hold the [5] and turn the machine ON. For non-touch panel without ten key models, press and hold the [Option] and turn the machine ON. 3) Double-click the "Filedg32.exe" to start, and select "Brother Maintenance USB Printer". 4) Drag and drop the firmware (upd file) in the FILEDG32 screen. Update is started.
3	Main PCB failure	Replace the main PCB ASSY.

\* By the above update procedure, the other models firmware can be updated to the machine. Check that the firmware is right and update correctly. If the other models firmware was updated by mistake, the machine may repeat power ON/OFF or not powered ON. In such case, replace the main PCB.

## 4.14.3 "Paper Low" message does not disappear

### <User Check>

- Turn the power switch OFF and then back ON again.
- Refill the paper in the appropriate paper tray.

Step	Cause	Remedy
1	Damaged plate-up plate in the paper tray	Replace the paper tray.
2	Paper feed motor failure	Replace the paper feed motor.
3	Damaged plate push-up mechanism in the machine	Replace the frame L unit.
4	Main PCB failure	Replace the main PCB ASSY.



#### 4.14.4 Message indicating that the report is full does not disappear

##### <User Check>

- Output each report.

Step	Cause	Remedy
1	Main PCB failure	Replace the main PCB ASSY.

#### 4.14.5 Paper tray cannot be recognized

##### <User Check>


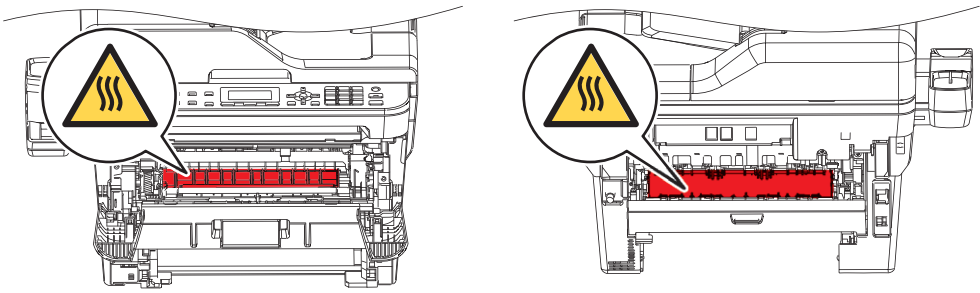
- Close the paper tray properly.

Step	Cause	Remedy
1	Connection failure of the T1 paper feed sensor harness (non paper empty sensor models only)	Reconnect the T1 paper feed sensor harness.
2	Connection failure of the T1 paper empty/paper feed sensor harness (paper empty sensor models only)	Reconnect the T1 paper empty/paper feed sensor harness.
3	T1 paper feed sensor PCB failure (non paper empty sensor models only)	Replace the T1 paper feed sensor PCB ASSY.
4	T1 paper empty/paper feed sensor PCB failure (paper empty sensor models only)	Replace the T1 paper empty/paper feed sensor PCB ASSY.
5	Main PCB failure	Replace the main PCB ASSY.


# CHAPTER 3 DISASSEMBLY/REASSEMBLY

## 1. SAFETY PRECAUTIONS

To avoid creating secondary problems by mishandling, follow the warnings and precautions below during maintenance work.

 <b>WARNING</b>
Some parts inside the machine are extremely hot immediately after the machine is used. When opening the front cover ASSY or back cover to access any parts inside the machine, never touch the shaded parts shown in the following figures.


- Be careful not to lose screws, washers, or other parts removed.
- Be sure to apply grease to applicable positions specified in this chapter.
- When using soldering irons or other heat-generating tools, take care not to accidentally damage parts such as wires, PCBs and covers.
- Static electricity charged in your body may damage electronic parts. When transporting PCBs, be sure to wrap them in conductive sheets.
- When replacing the PCB and all the other related parts, put on a grounding wrist band and perform the job on a static mat. Also take care not to touch the conductor sections on the flat cables or on the wire harness.
- After disconnecting flat cables, check that each cable is not damaged at its end or shortcircuited.
- When connecting flat cables, do not insert them at an angle. After insertion, check that the cables are not at an angle.
- When connecting or disconnecting harnesses, hold the connector body, not the cables. If the connector is locked, release it first.
- After a repair, check not only the repaired portion but also harness treatment. Also check that other related portions are functioning properly.
- Forcefully closing the front cover without mounting the toner cartridge and the drum unit can damage the machine.
- After assembly, it is recommended to conduct dielectric strength test and continuity test.
- When mounting the inlet, check that the inlet is housed in the frame completely and that the harness is not caught in the frame.
- The insulation sheet should not be damaged.
- After a repair, update the firmware to the latest version.

 <b>WARNING</b>	When removing the Low-voltage power supply, do not touch it within <b>3 minutes</b> after disconnecting the AC cord as it may cause an electric shock due to the electric charge accumulated in the capacitor.
--	--

# 2. PACKING

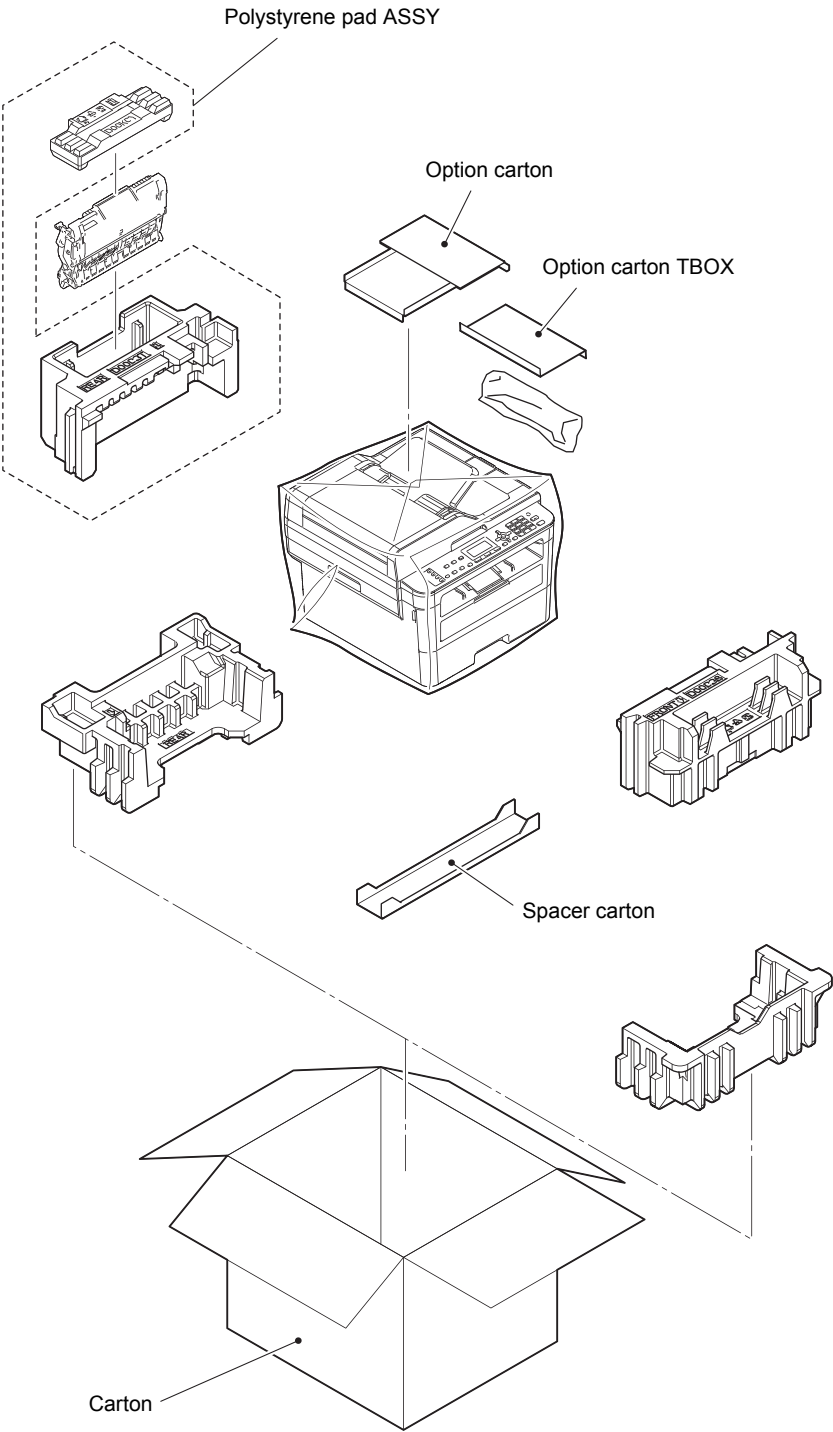
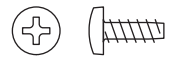




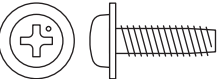
Fig. 3-1

### 3. SCREW CATALOGUE


#### Taptite bind B

Taptite bind B M3x8	
Taptite bind B M3x10	
Taptite bind B M4x12	

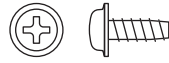
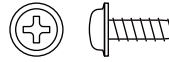
#### Taptite pan B

Taptite pan B M4x14	
------------------------	---



#### Screw pan

Screw pan M4x8	
-------------------	--



#### Taptite cup B

Taptite cup B M3x8	
Taptite cup B M3x10	


#### Screw cup

Screw cup M3x6	
Screw cup M3x8	

#### Taptite cup S

Taptite cup S M3x6 SR	
Taptite cup S M3x8 SR	

#### Screw pan (S/P washer)

Screw pan (S/P washer) M3x12DB	
-----------------------------------	--

#### Screw bind


Screw bind M3x4	
--------------------	---

Fig. 3-2

## 4. SCREW TORQUE LIST

Location of screw	Screw type	Q'ty	Tightening torque N·m (kgf·cm)
Side cover R	Taptite bind B M4x12	1	0.8±0.1 (8±1)
Inner chute ASSY	Taptite bind B M4x12	2	0.8±0.1 (8±1)
Side cover L	Taptite bind B M4x12	1	0.8±0.1 (8±1)
Handset holder ASSY (For models with handset)	Taptite bind B M4x12	2	0.8±0.1 (8±1)
Upper handset holder (For models with handset)	Taptite cup B M3x8	1	0.5±0.1 (5±1)
FB ground harness	Screw cup M3x8 (black)	1	0.45±0.05 (4.5±0.5)
Panel ground harness			
ADF ground harness (For models with ADF)	Screw cup M3x8 (black)	1	0.45±0.05 (4.5±0.5)
Hinge ASSY L (For models with ADF)	Taptite bind B M4x12 (black)	1	0.8±0.1 (8±1)
Hinge ASSY L (For models with ADF)	Taptite bind B M4x12	3	0.8±0.1 (8±1)
Hinge R support (For models with ADF)	Taptite cup B M3x10	1	0.5±0.1 (5±1)
Hinge arm R (For models with ADF)	Taptite cup B M3x10	3	0.5±0.1 (5±1)
ADF front cover (For models with ADF)	Taptite cup B M3x10	2	0.5±0.1 (5±1)
ADF separation holder ASSY (For models with ADF)	Taptite cup B M3x10	1	0.5±0.1 (5±1)
Upper document chute (For models with ADF)	Taptite cup B M3x10	6	0.5±0.1 (5±1)
ADF ground harness (For models with ADF)	Screw cup M3x6 (black)	1	
Hinge arm L (For models without ADF)	Taptite cup B M3x10	3	0.5±0.1 (5±1)
Hinge arm R (For models without ADF)	Taptite cup B M3x10	3	0.5±0.1 (5±1)
Panel unit	Taptite cup B M3x10	4	0.5±0.1 (5±1)
Shield plate cover (Touch panel models)	Taptite cup B M3x10	4	0.5±0.1 (5±1)
Panel key PCB presser (Touch panel models)	Taptite cup B M3x10	4	0.5±0.1 (5±1)
Document scanner top cover	Taptite bind B M4x12	6	0.8±0.1 (8±1)
Modem ground harness LVPS	Screw cup M3x8 (black)	2	0.45±0.05 (4.5±0.5)
Modem ground harness main	Screw cup M3x8 (black)	2	0.45±0.05 (4.5±0.5)
Modem shield plate	Taptite bind B M4x12	2	0.8±0.1 (8±1)
Modem shield cover	Screw cup M3x8 (black)	1	0.45±0.05 (4.5±0.5)
Modem PCB ASSY	Screw cup M3x8 (black)	3	0.45±0.05 (4.5±0.5)
Joint cover ASSY	Taptite bind B M4x12	4	0.8±0.1 (8±1)
Fuser unit	Taptite pan B M4x14	2	0.8±0.1 (8±1)
LVPS shield plate cover	Screw cup M3x8 (black)	2	0.45±0.05 (4.5±0.5)
	Screw pan M4x8	1	0.45±0.05 (4.5±0.5)
Ground harness	Screw pan M4x8	1	0.45±0.05 (4.5±0.5)

Location of screw		Screw type	Q'ty	Tightening torque N·m (kgf·cm)
Low-voltage power supply PCB ASSY		Screw cup M3x8 (black)	2	0.45±0.05 (4.5±0.5)
High-voltage power supply PCB ASSY		Screw cup M3x8 (black)	1	0.45±0.05 (4.5±0.5)
Toner box relay PCB ASSY (For models with toner box)/ MP relay PCB ASSY (For MP models)		Taptite bind B M4x12	1	0.8±0.1 (8±1)
Toner box new PCB ASSY (For models with toner box)		Taptite bind B M3x8	1	0.45±0.05 (4.5±0.5)
Laser unit		Taptite cup S M3x8 SR	4	0.8±0.1 (8±1)
Main PCB FG plate 1		Screw cup M3x8 (black)	2	0.6±0.1 (6±1)
Main PCB ASSY		Screw cup M3x8 (black)	4	0.6±0.1 (6±1)
MP frame parts (For MP models)		Taptite bind B M4x12	3	0.8±0.1 (8±1)
		Taptite pan B M4x14	1	0.8±0.1 (8±1)
Front chute ASSY	For manual feed models	Taptite bind B M4x12	2	0.8±0.1 (8±1)
		Screw pan (S/P washer) M3x12DB	1	0.5±0.1 (5±1)
	For MP models	Taptite bind B M4x12	3	0.8±0.1 (8±1)
Frame L unit		Taptite bind B M4x12 (11a) (Under bar)	1	0.8±0.1 (8±1)
		Taptite cup S M3x6 SR (11b) (for securing the chute ground plate)	1	0.5±0.1 (5±1)
		Taptite bind B M4x12 (11c) (for securing the registration chute)	1	0.8±0.1 (8±1)
		Taptite cup S M3x8 SR (11d) (for securing the laser L FG plate)	1	0.8±0.1 (8±1)
		Taptite bind B M4x12 (12a)	2	0.8±0.1 (8±1)
		Taptite cup S M3x8 SR (12b)	2	0.8±0.1 (8±1)
Flat cable guide		Taptite bind B M4x12	1	0.8±0.1 (8±1)
Laser L FG plate		Screw pan (S/P washer) M3x12DB	1	0.5±0.1 (5±1)
Motor drive sub ASSY		Taptite bind B M4x12	3	0.8±0.1 (8±1)
		Taptite cup S M3x8 SR	1	0.8±0.1 (8±1)
Paper feed motor		Screw bind M3x4	3	0.65±0.05 (6.5±0.5)
Toner box drive cover		Taptite bind B M4x12	2	0.8±0.1 (8±1)
Toner sensor PCB ASSY		Taptite bind B M3x8	1	0.4±0.05 (4±0.5)
Holder toner box		Taptite bind B M4x12	3	0.8±0.1 (8±1)
Lift cam guide		Taptite bind B M4x12	1	0.8±0.1 (8±1)
Main shield plate		Taptite cup S M3x8 SR	1	0.5±0.1 (5±1)
		Screw pan (S/P washer) M3x12DB	1	0.5±0.1 (5±1)
LVPS shield plate		Taptite cup S M3x8 SR	1	0.55±0.05 (5.5±0.5)
		Taptite bind B M4x12	1	0.8±0.1 (8±1)
Frame R unit		Taptite cup S M3x6 SR	1	0.5±0.1 (5±1)
		Taptite bind B M4x12	2	0.8±0.1 (8±1)
Registration front/rear actuator holder ASSY		Taptite bind B M3x10	1	0.5±0.1 (5±1)

## 5. LUBRICATION

Lubricating oil type (Maker name)	Lubrication point		Quantity of lubrication
BDX313 (A) (Kanto Kasei)	Hinge ASSY L	9 places	2.0 mm dia. ball
FLOIL BG-10KS (Kanto Kasei)	Fuser gear 64R/36R	3 places	1.5 to 2.0 mm dia. ball

### ■ Hinge ASSY L

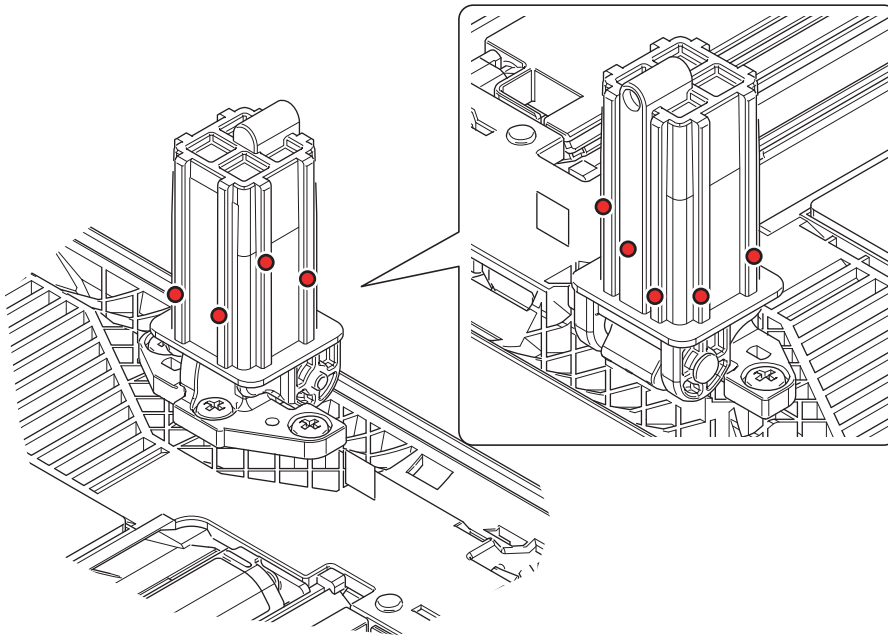


Fig. 3-3

### ■ Fuser gear 64R/36R

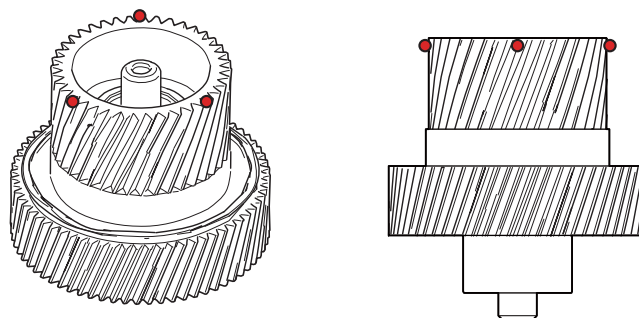


Fig. 3-4

## 6. OVERVIEW OF GEARS

<Layout view>

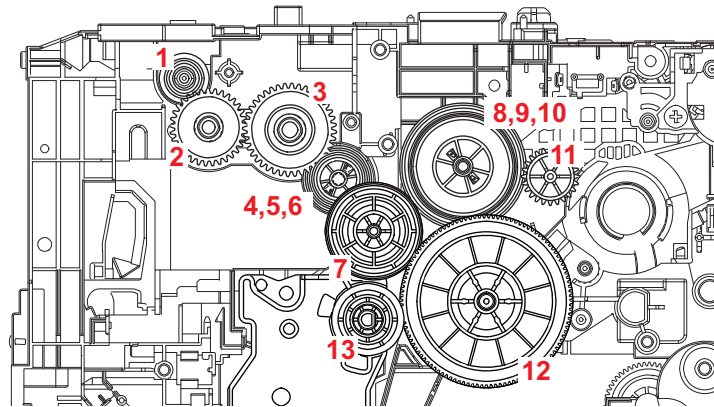


Fig. 3-5

<Development view>

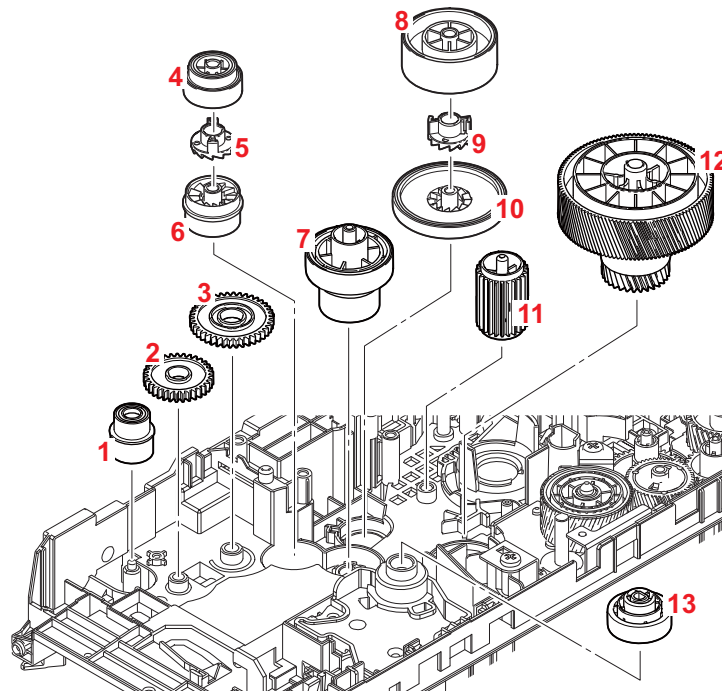


Fig. 3-6

**Note:**

- When handling gears, make sure that frame L faces up. Otherwise all gears come off.

<Name of gears>

1	D00AHW	Ejector gear 16/15	8	D00HHK	Gear 70R DEV
2	LY9006	Ejector gear 33	9	D00HHM	Clutch DEV NON toner box
3	LY9005	Ejector gear 40	10	D00HHL	Gear 55 DEV
4	D00ALK	Gear oneway 35L/22 fuser	11	D00EFZ	Gear DEV idle 24
5	D00ALM	Clutch fuser	12	D00AKE	Gear 115L 30L drum
6	D00ALL	Gear oneway 20 fuser	13	D00AH4	Gear 47R DX
7	D00ALH	Gear 64R/36R fuser			

\* These parts are subject to change without notice.



<Layout view>

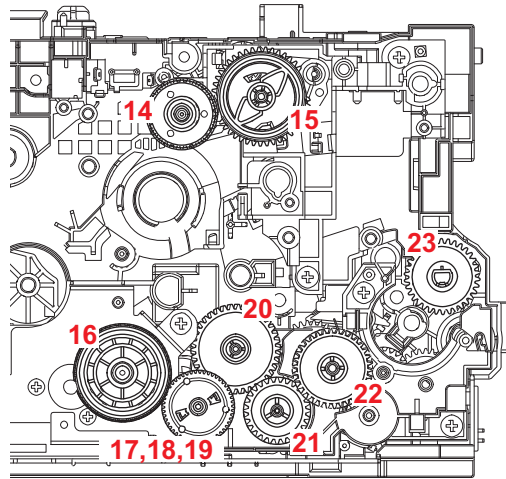


Fig. 3-7

<Development view>

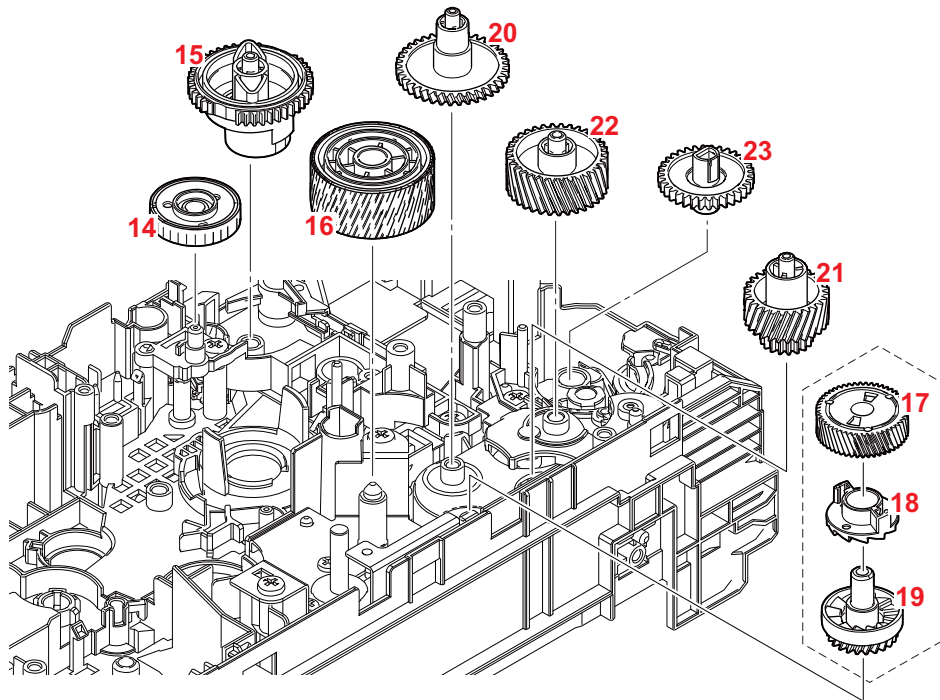


Fig. 3-8

**Note:**

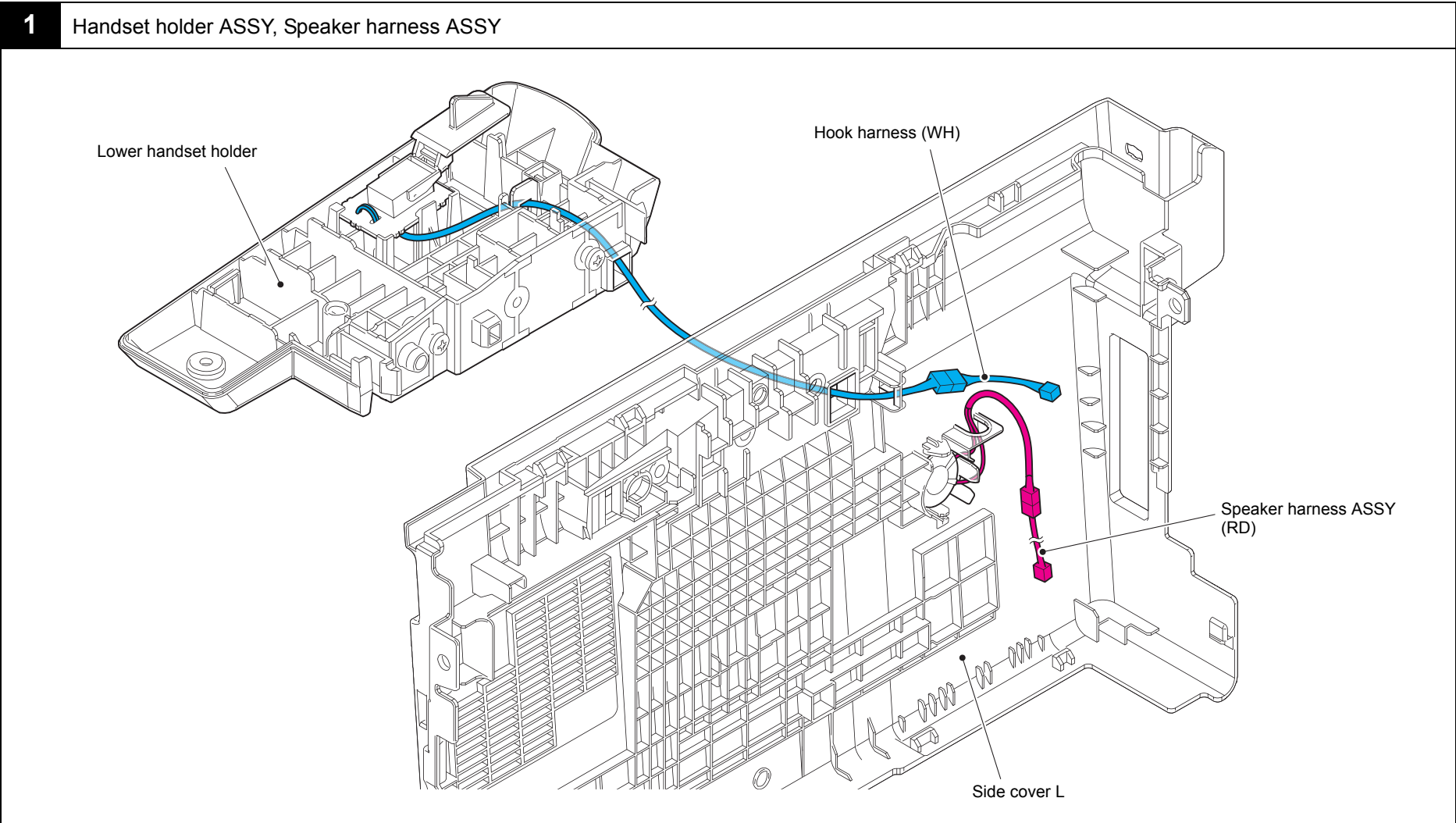
- When handling gears, make sure that frame L faces up. Otherwise all gears come off.

<Name of gears>

14	D00EGI	Gear toner box idle 32	19	D00CXT	Gear 23R PF
15	D00CUB	Sector gear toner box	20	D00AK9	Gear 38L PF
16	D00AM4	Gear 68R drum idle	21	D00AK8	Gear 28R/18 PF
17	D00AKA	Gear 50L PF	22	D00AK7	Gear 34L PF
18	D00CXU	Clutch PF	23	LY9088	Feeder gear 34

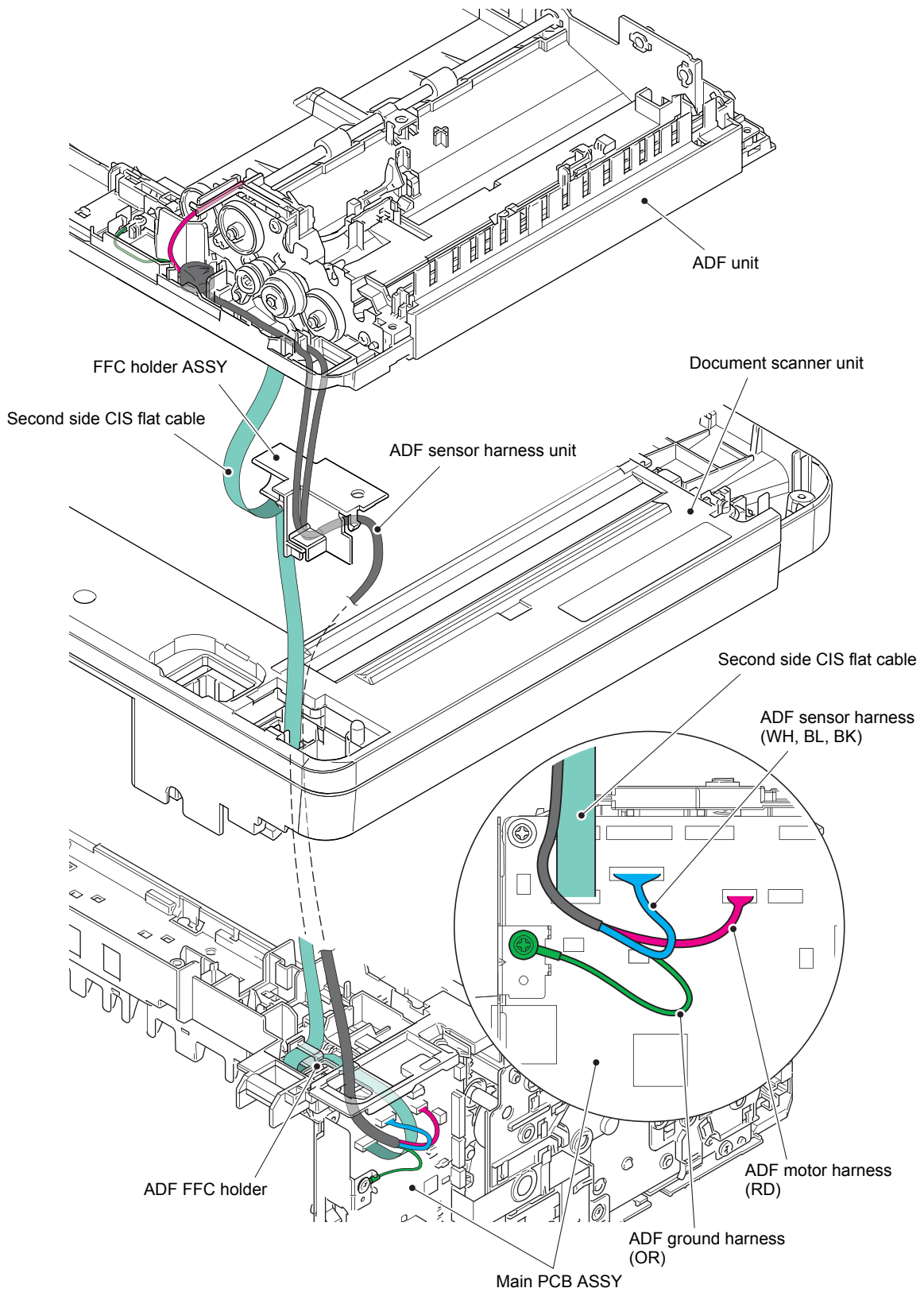
\* These parts are subject to change without notice.

# 7. HARNESS ROUTING



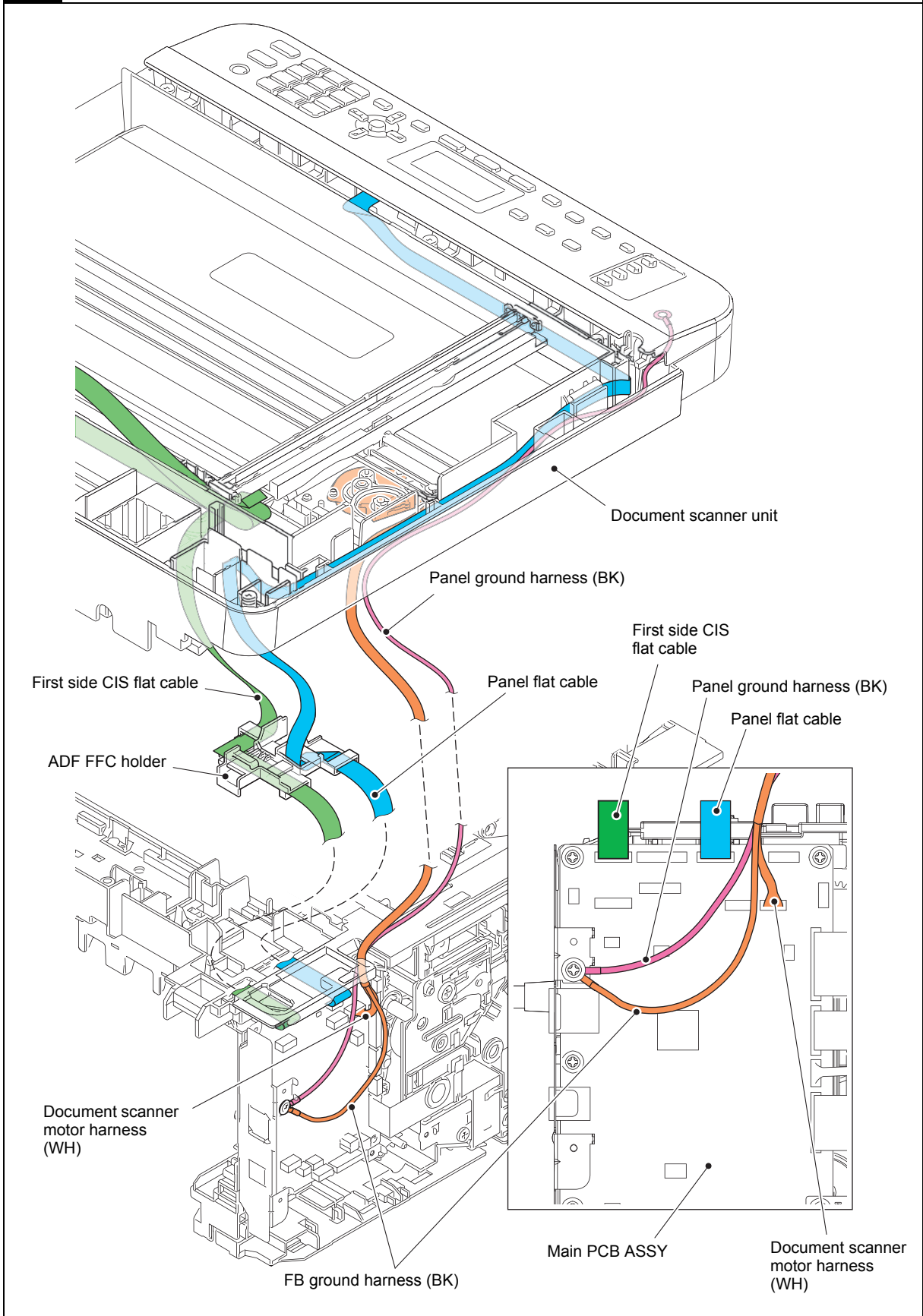
Harness colors are subject to change for some reason.

**2** ADF unit

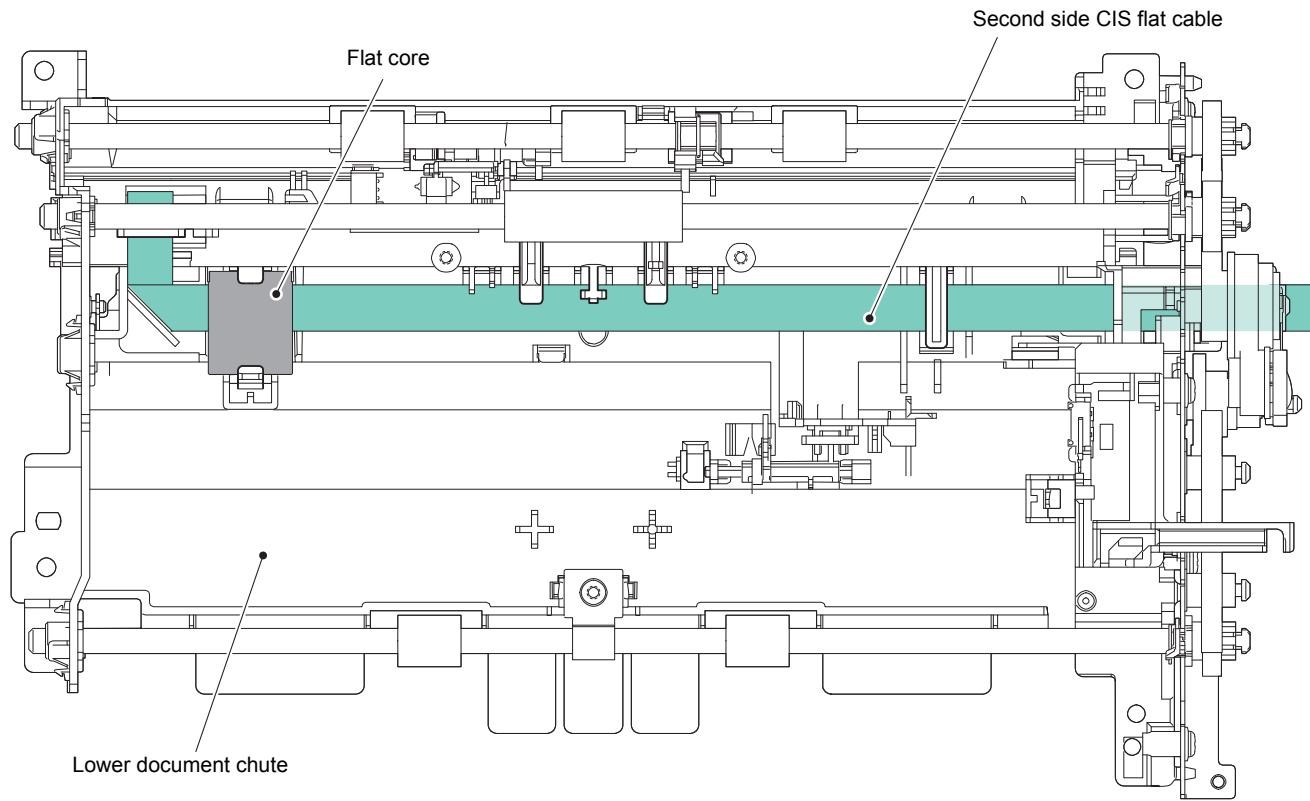


Harness colors are subject to change for some reason.

### 3 Document scanner unit

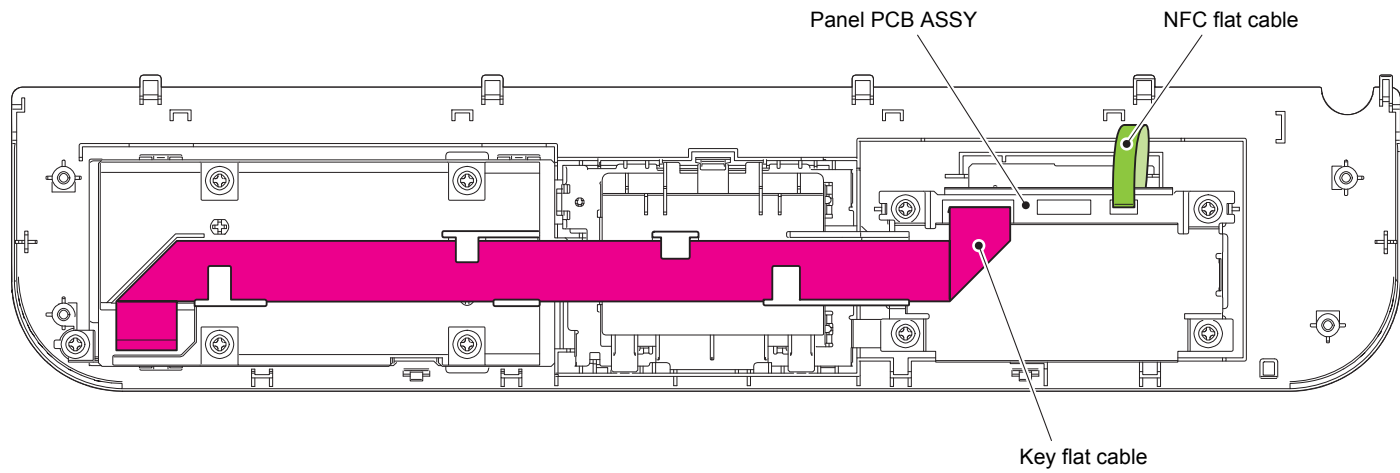


Harness colors are subject to change for some reason.



Harness colors are subject to change for some reason.

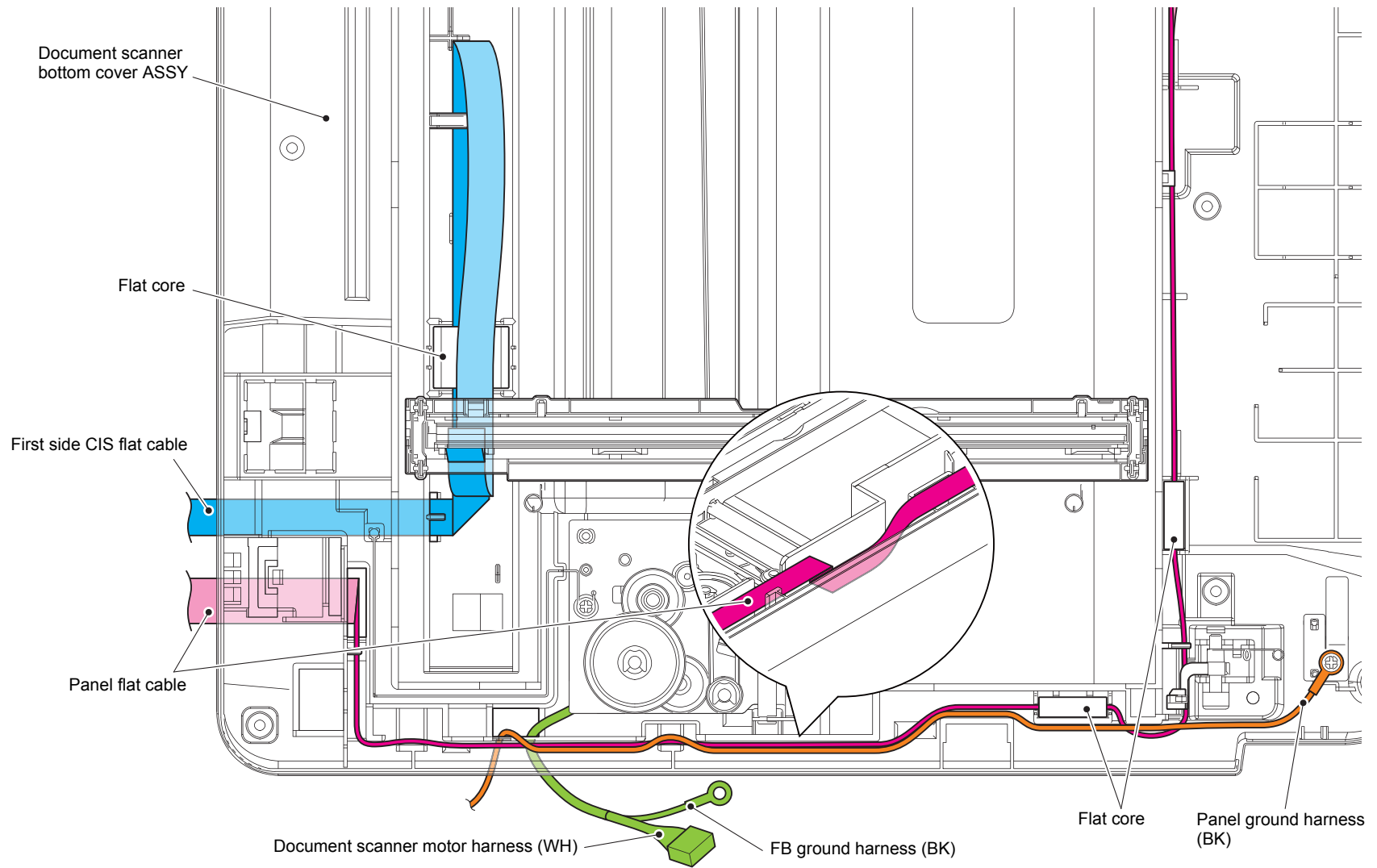
**5** Panel unit



Harness colors are subject to change for some reason.

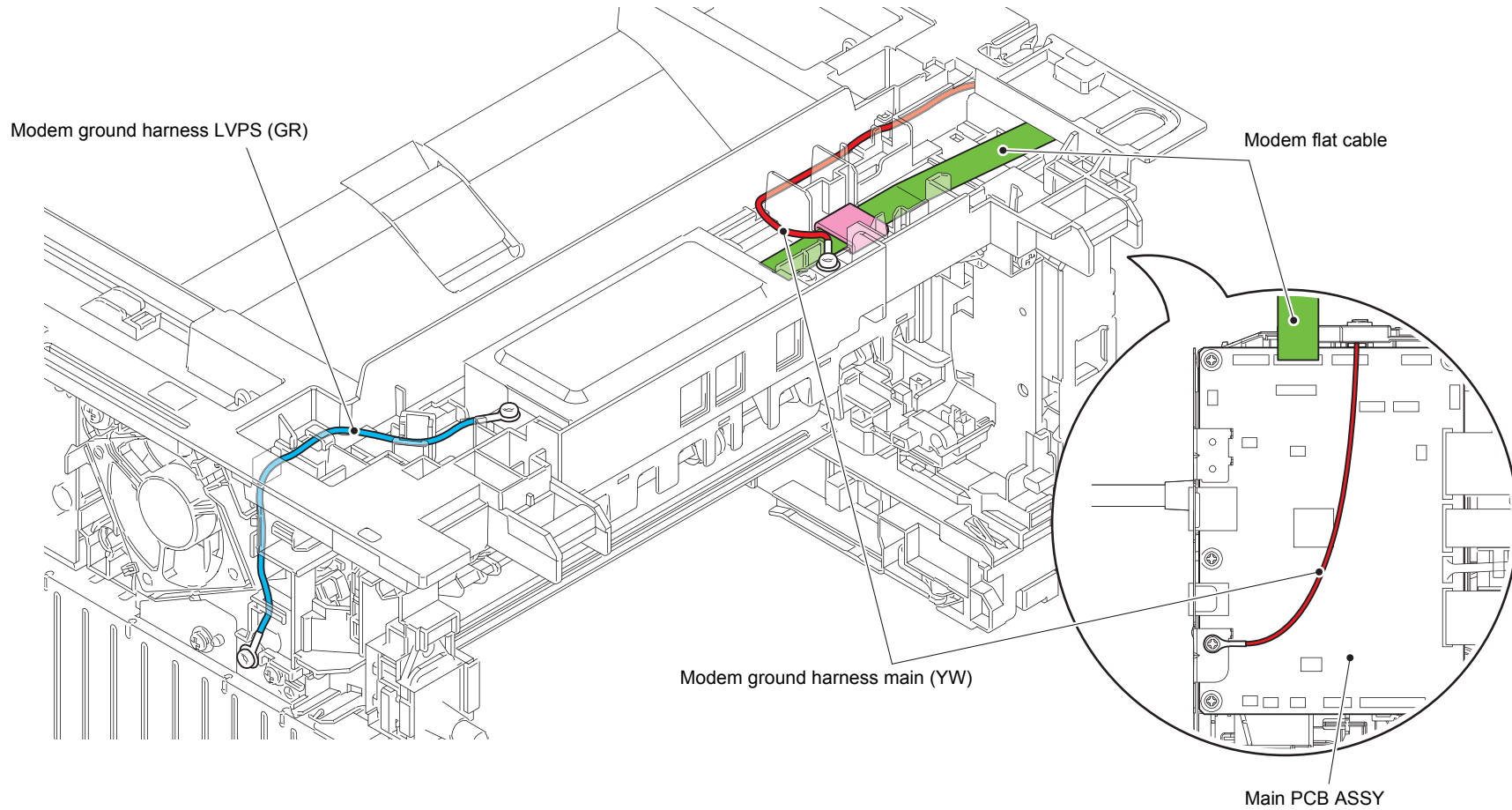
6

First side CIS unit, Panel



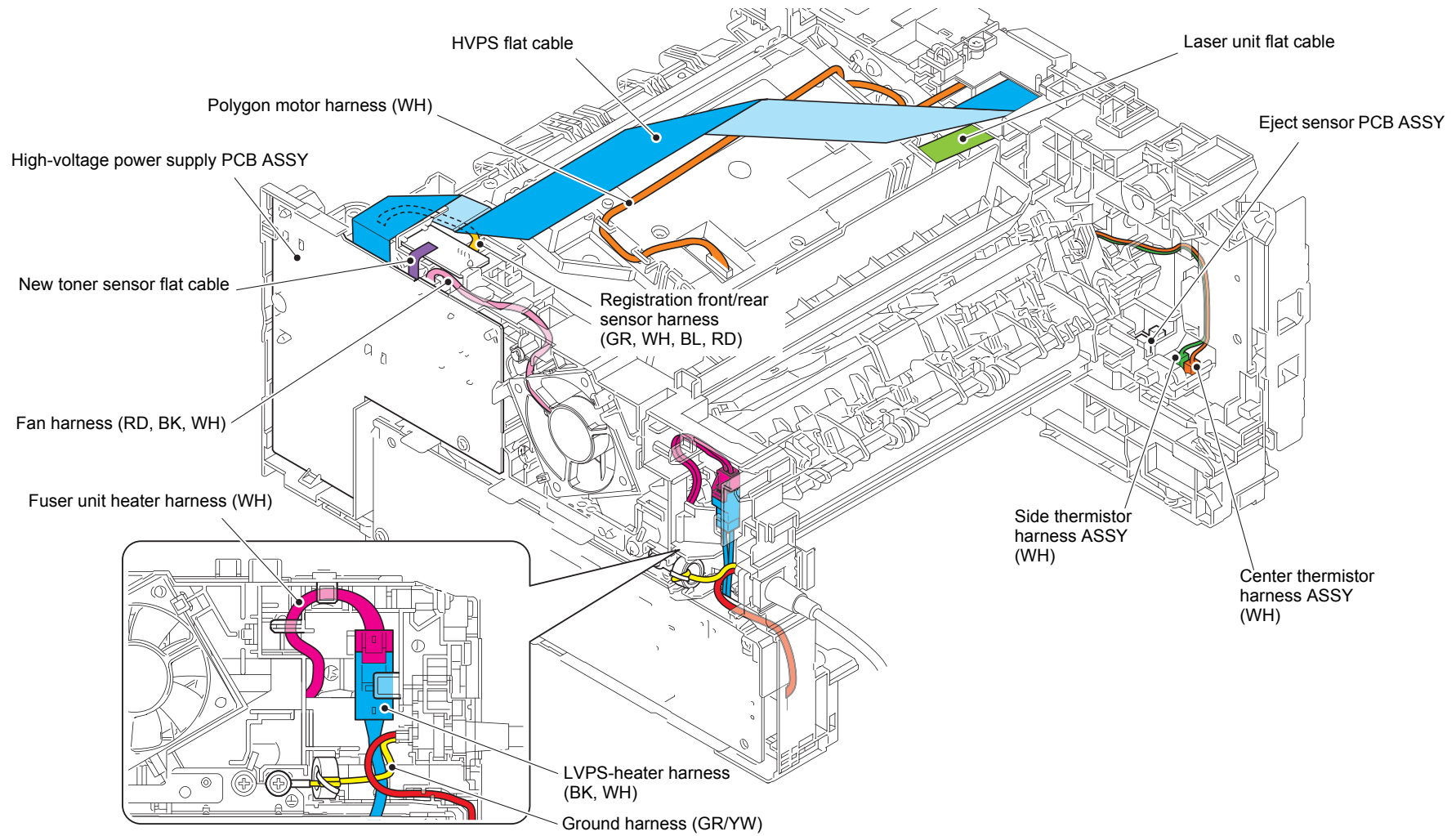
Harness colors are subject to change for some reason.



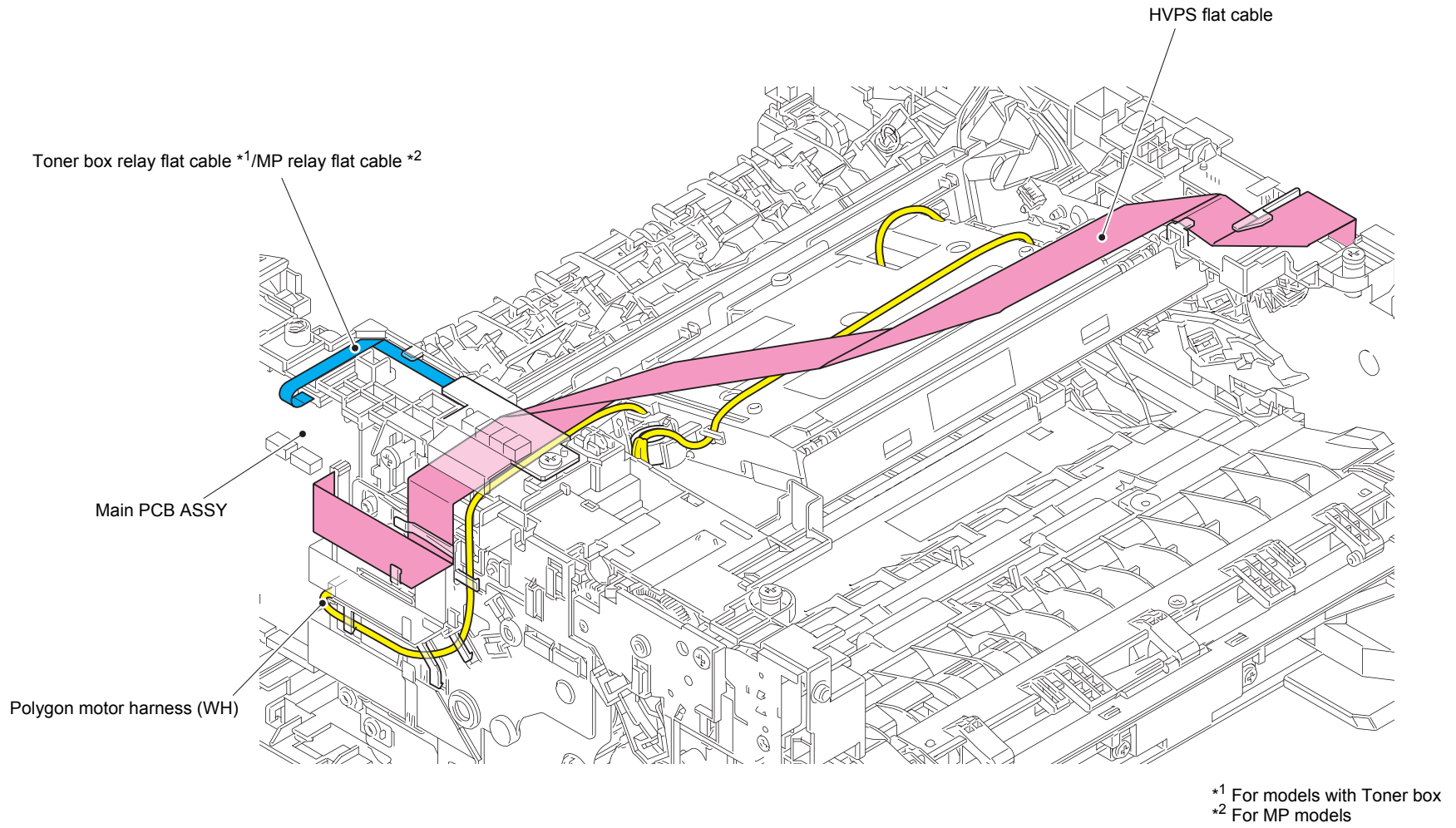


Harness colors are subject to change for some reason.



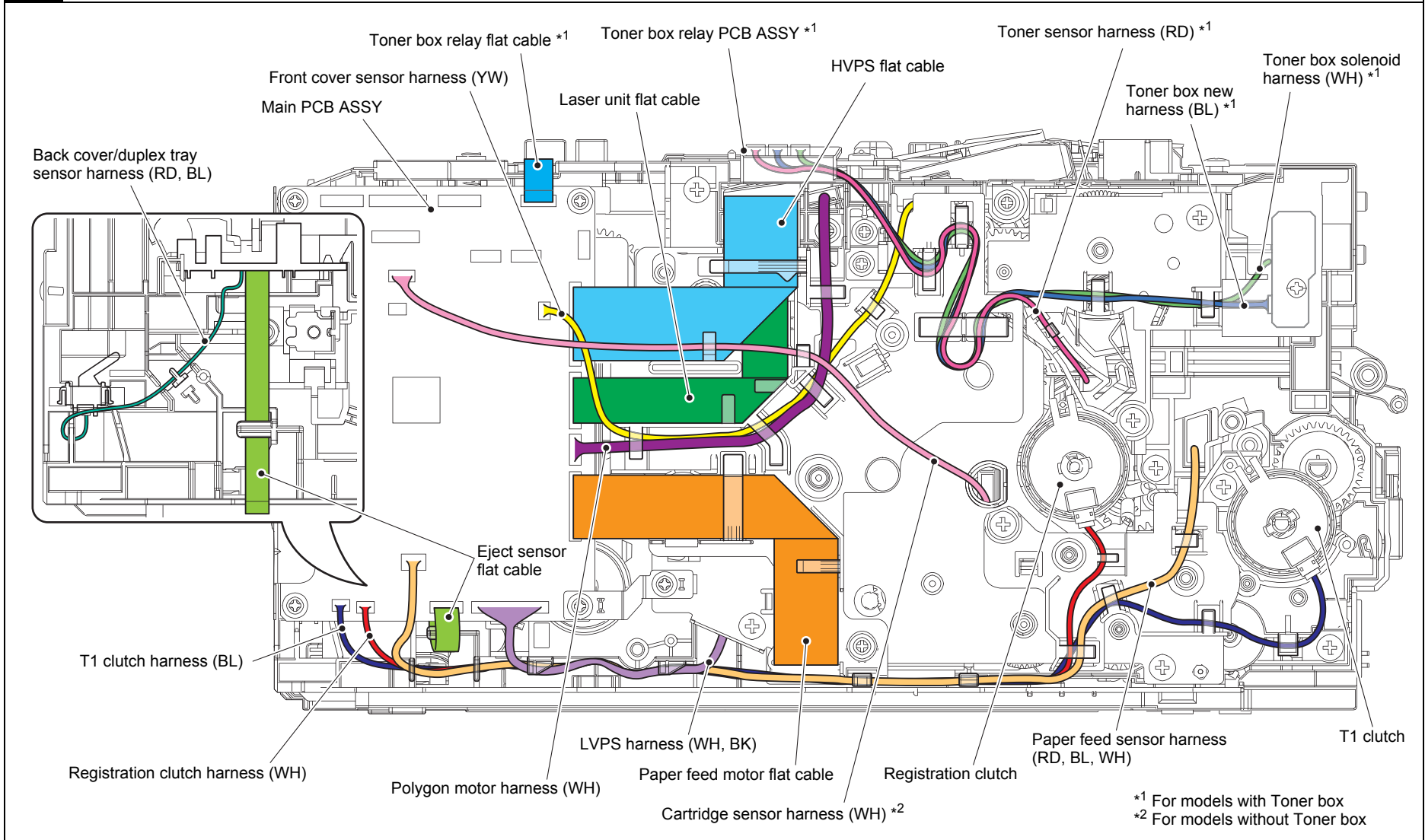


Harness colors are subject to change for some reason.



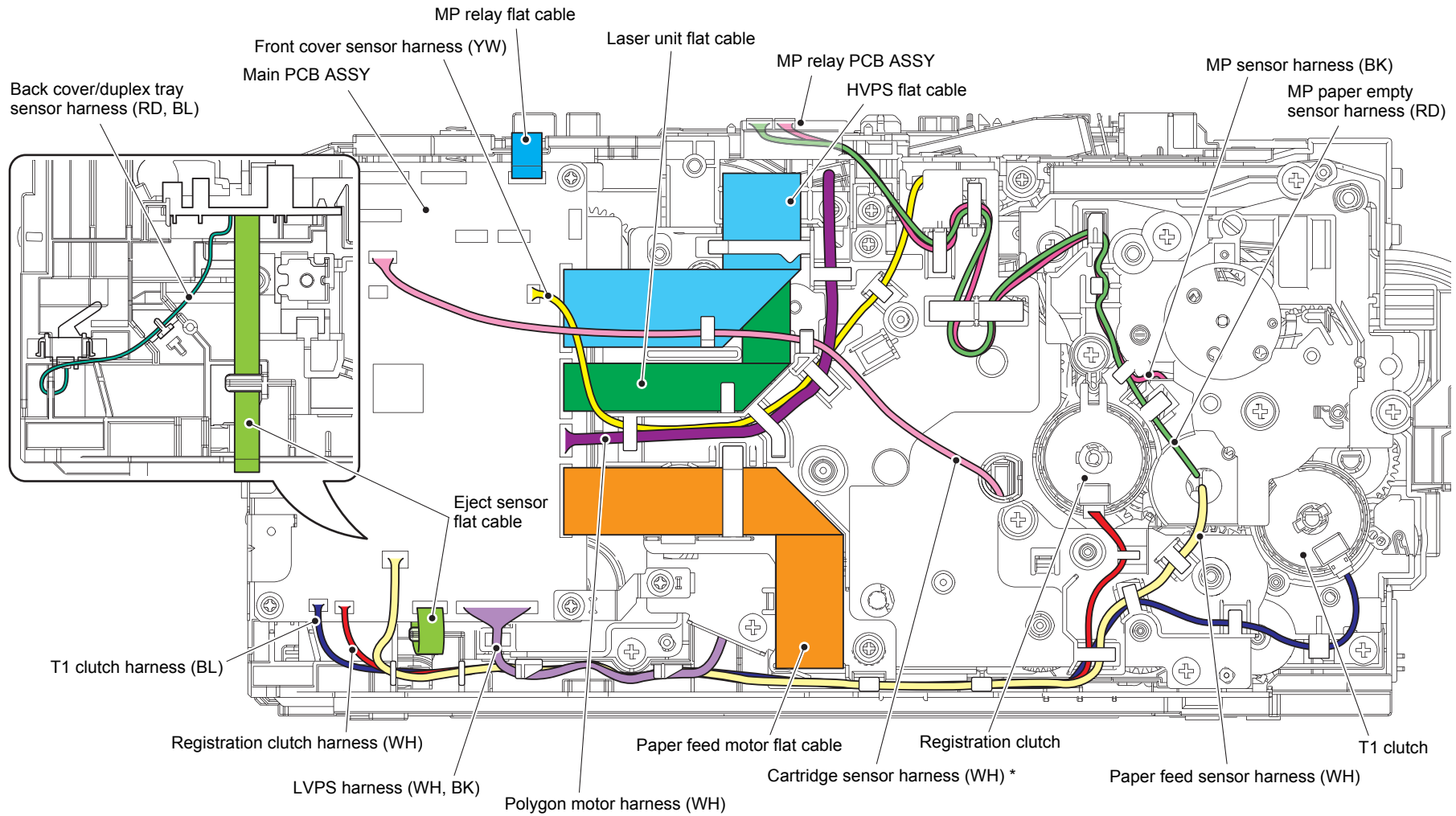
Harness colors are subject to change for some reason.

**10** Frame L unit (Manual feed models)



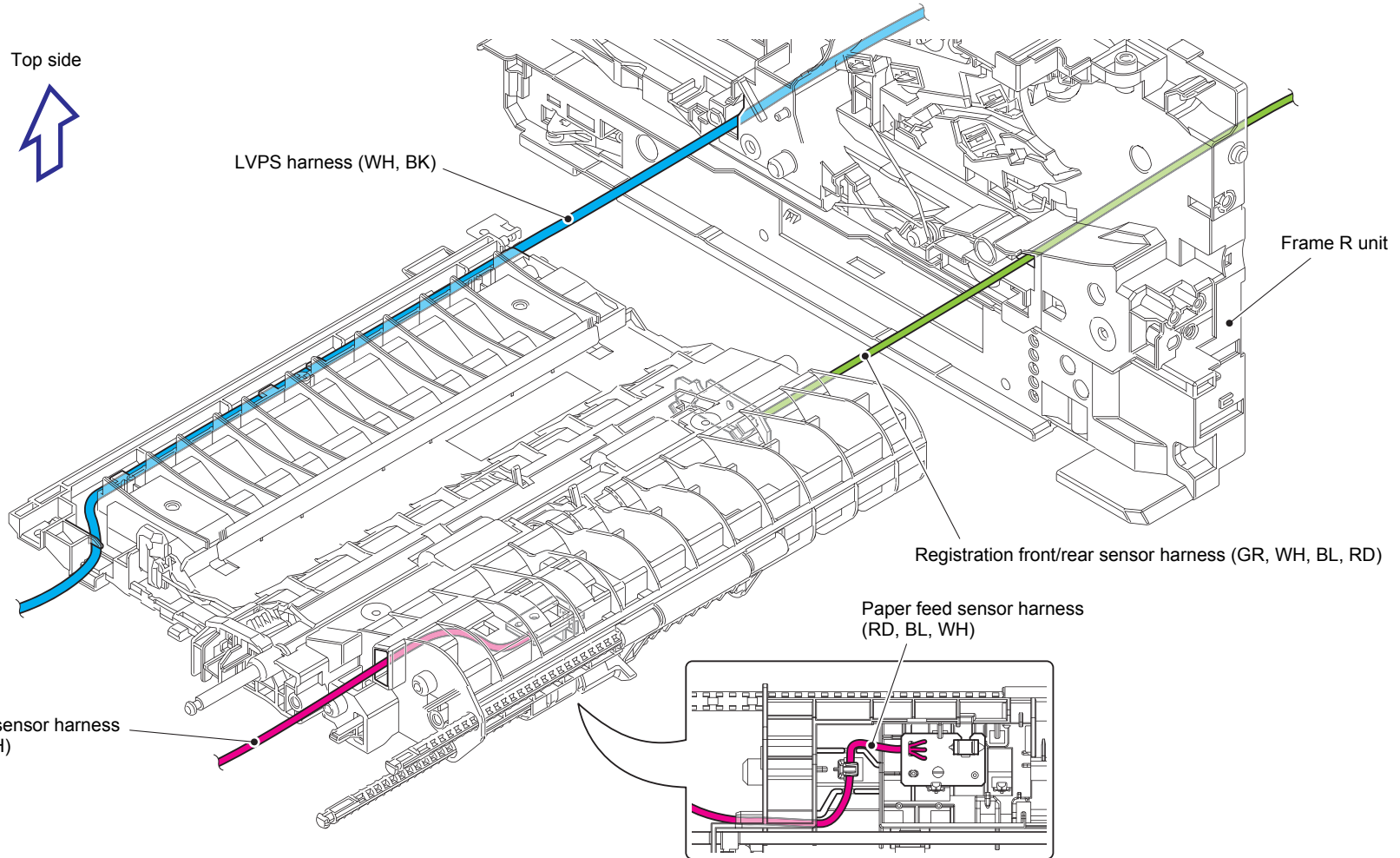
Harness colors are subject to change for some reason.

**11** Frame L unit (MP models)



\* For models without Toner box

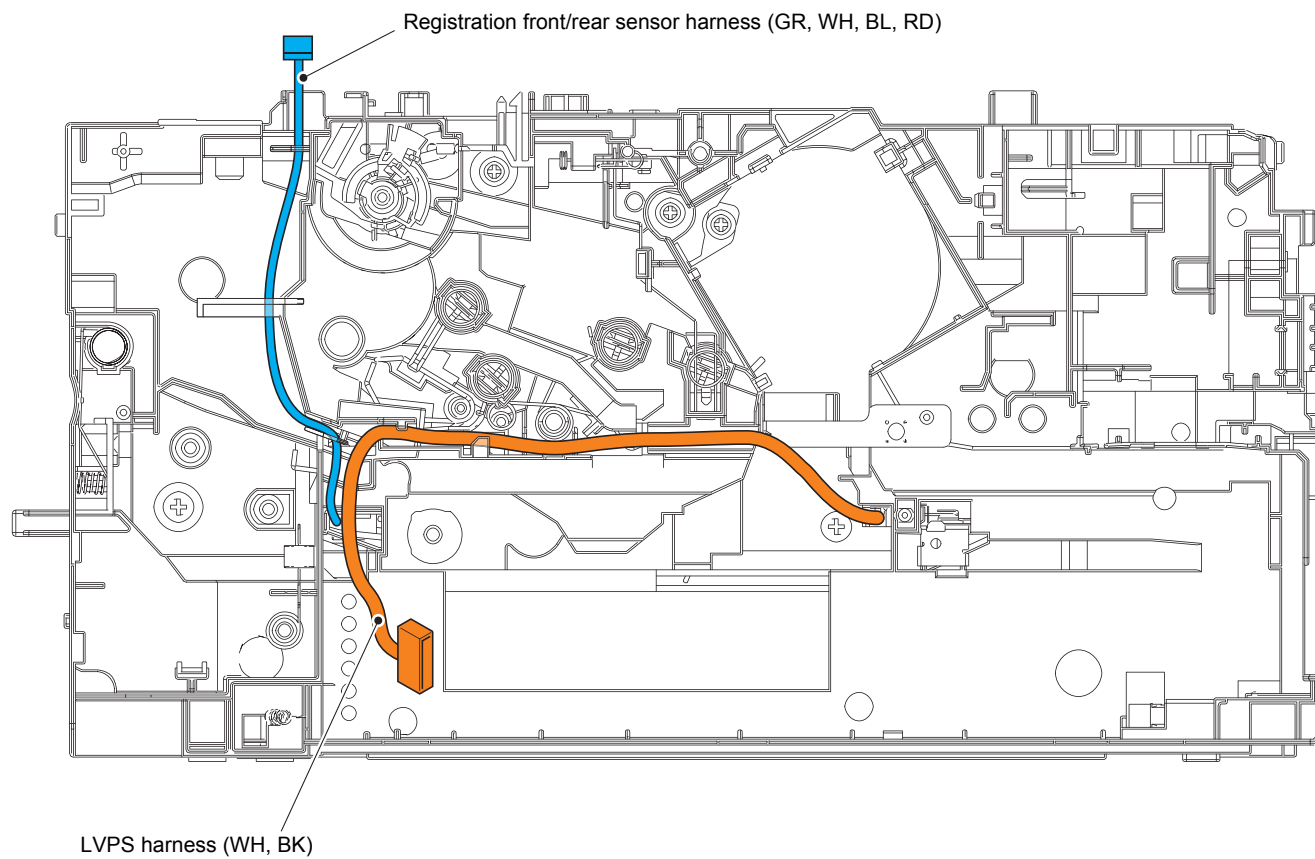
Harness colors are subject to change for some reason.



Harness colors are subject to change for some reason.



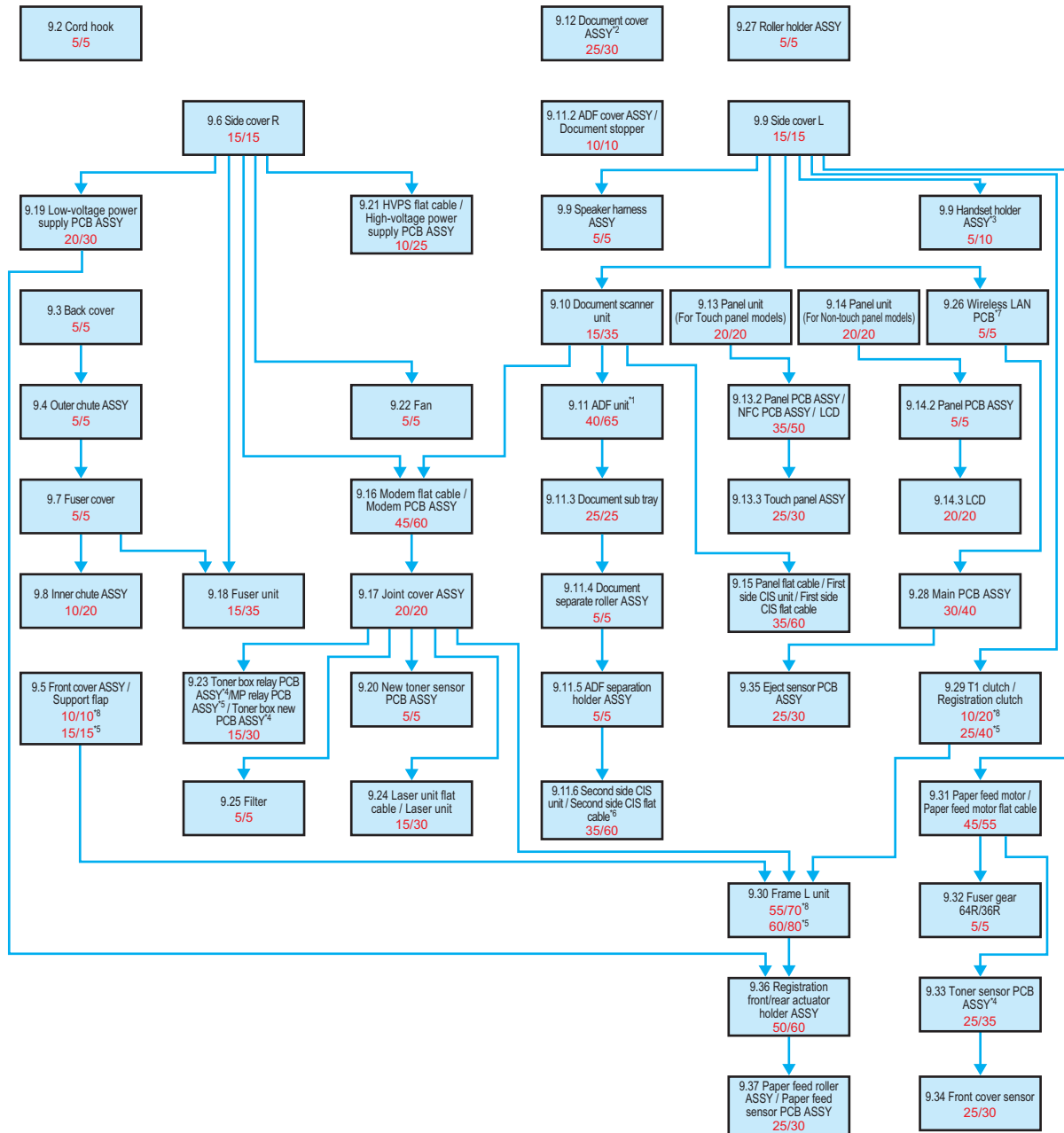
**13** Frame R unit



Harness colors are subject to change for some reason.

# 8. DISASSEMBLY FLOW CHART

## Disassembly / Reassembly (second)



- \*1 For models with ADF
- \*2 For models without ADF
- \*3 For models with Handset
- \*4 For models with Toner box
- \*5 For MP models
- \*6 Only for models with duplex scanning
- \*7 Only for wireless network models
- \*8 For manual feed models

# 9. DISASSEMBLY PROCEDURE

---

## 9.1 Preparation

### ■ Transferring Received FAX Data

In case of machine failure, unplugging the AC cord is required for sending the machine to repair. In this regard, received fax data left in the machine would be lost.

To prevent such data loss, fax files left in the machine can be transferred to other fax machines or PCs. Service personnel should instruct end users (e.g., by telephone) to transfer data by themselves using the procedure below.

**Note:**

- The number of files that can be transferred at a time is 99. When there are 100 or more files, the operation procedure below must be performed several times to transfer all files.

**TIP:**

- If there are both color and monochrome data in a file to be transferred, the monochrome data will be transferred first. If the receiver machine does not support the color function, the sender machine cannot transfer color data, resulting in an error.

Transfer the received FAX data as described in “[1.3.14 Transfer received fax data / log information \(fax models only\) \(Function code 53\)](#)” in Chapter 5.



## ■ Disconnecting Cables and Removing Accessories

Prior to proceeding with the disassembly procedure,

- (1) Disconnect the following:
  - USB cable (if connected)
  - LAN cable (if connected)
  - Handset curled cord (if connected)
  - Line cord (if connected)
- (2) Remove the following:
  - Paper tray
  - Toner cartridge & Drum unit or Toner box & Process unit
  - Duplex tray
  - LAN port cap
  - EXT cap
  - Handset

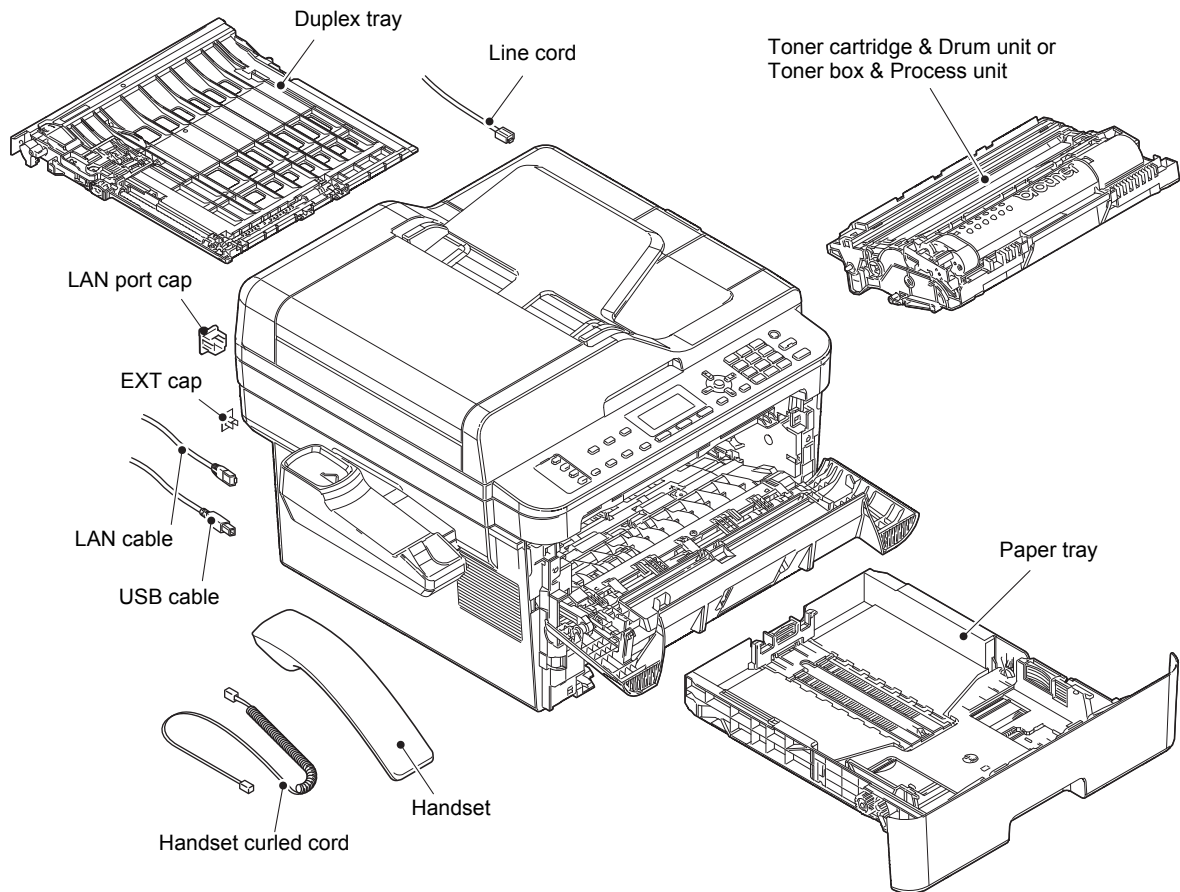


Fig. 3-9

# 9.2 Cord hook

(1) Rotate the Cord hook by 90 degrees to remove it. (two locations)

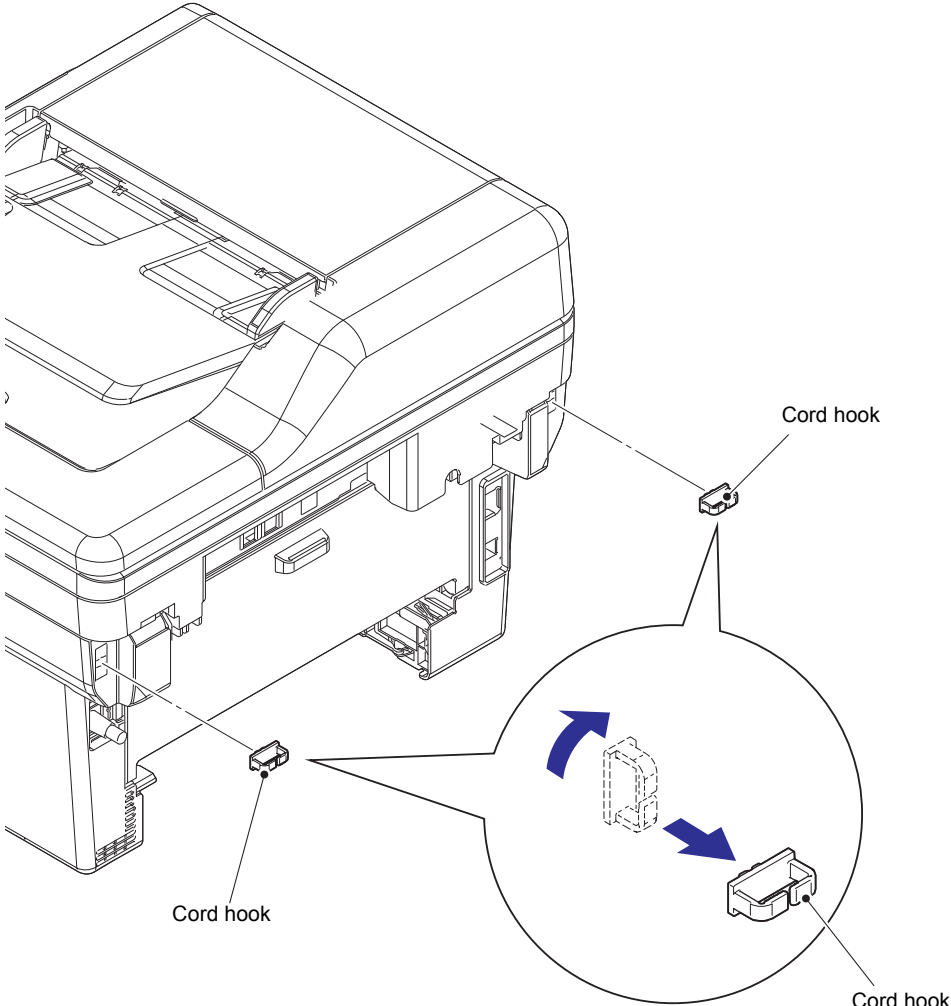


Fig. 3-10

### 9.3 Back cover

- (1) Open the Back cover.
- (2) Push both Ribs on the Back cover outward, and remove the Pin on the Outer chute ASSY.
- (3) Pull out the right side of the Back cover in the direction of the arrow A to remove it from the Boss, and remove the Back cover in the direction of the arrow B.

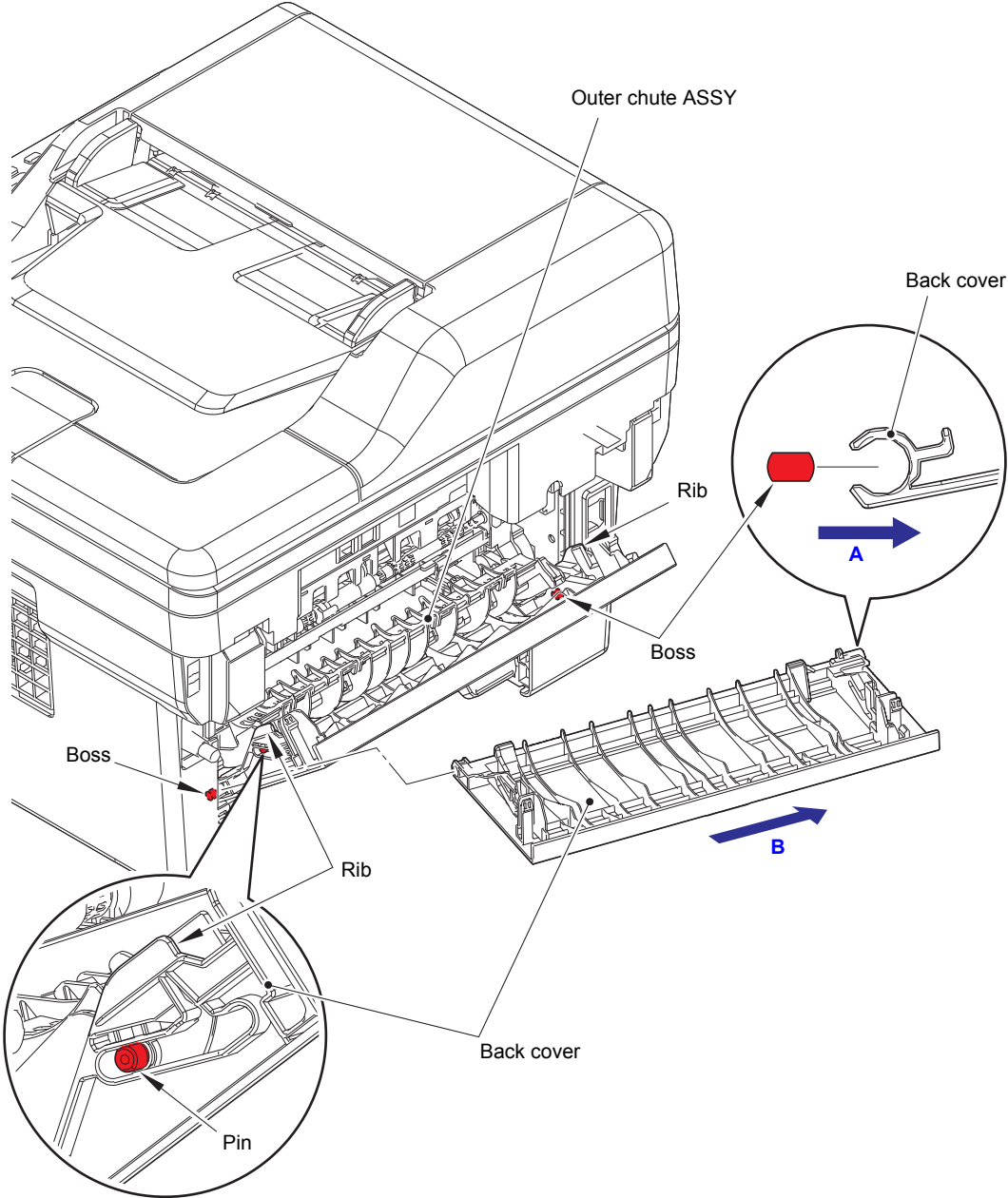


Fig. 3-11

# 9.4 Outer chute ASSY

- (1) Pull out the right side of the Outer chute ASSY in the direction of the arrow A to remove the Boss of the Outer chute ASSY, and remove the Outer chute ASSY in the direction of the arrow B.

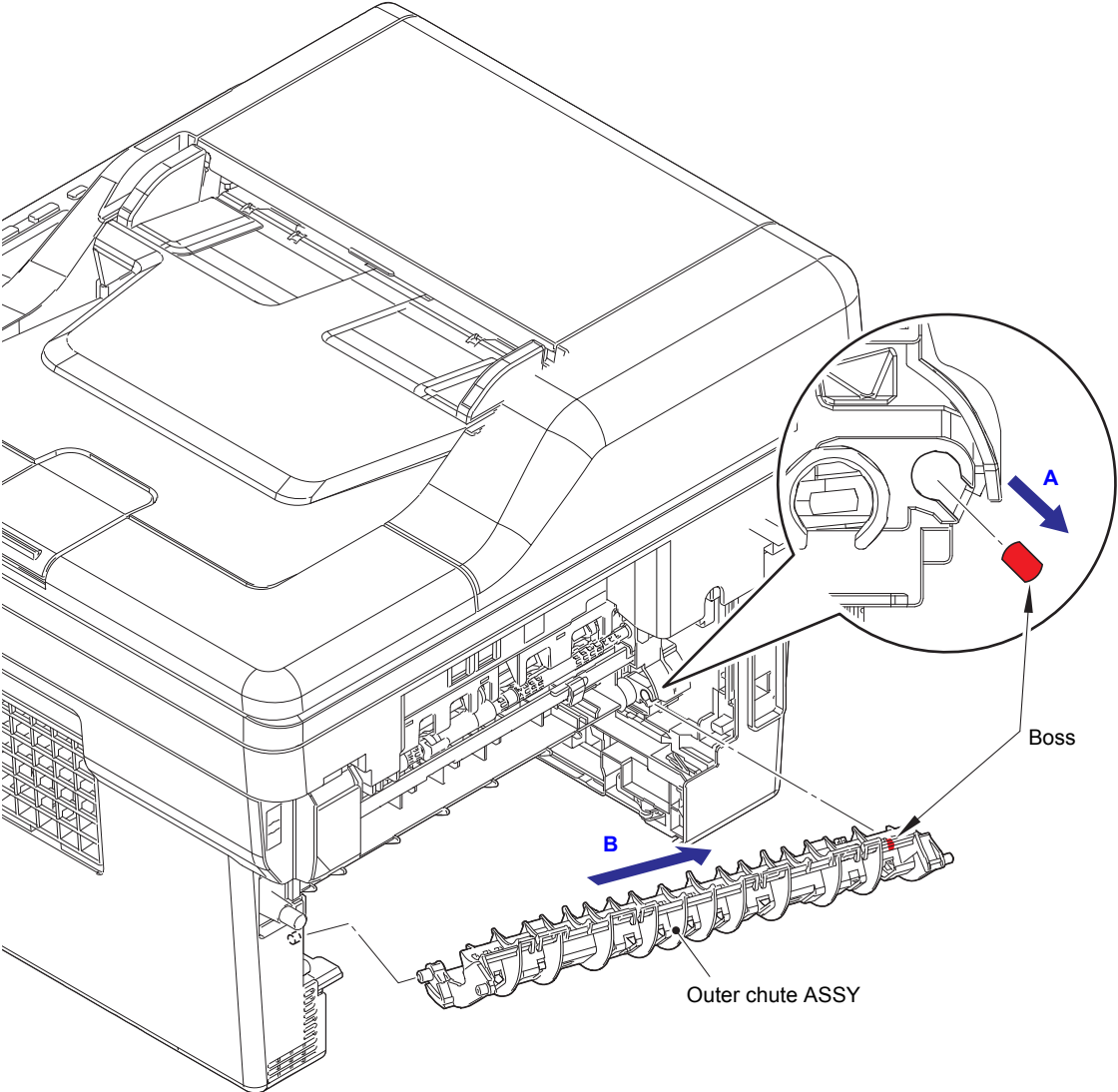


Fig. 3-12

## 9.5 Front cover ASSY / Support flap

### ■ Manual feed models

- (1) Open the Front cover ASSY.
- (2) Remove the Collar 4 to remove the Develop joint link from the Front cover ASSY.
- (3) Lift the Rib on the Front chute ASSY, and slide the Front cover ASSY in the direction of the arrow A to remove it.

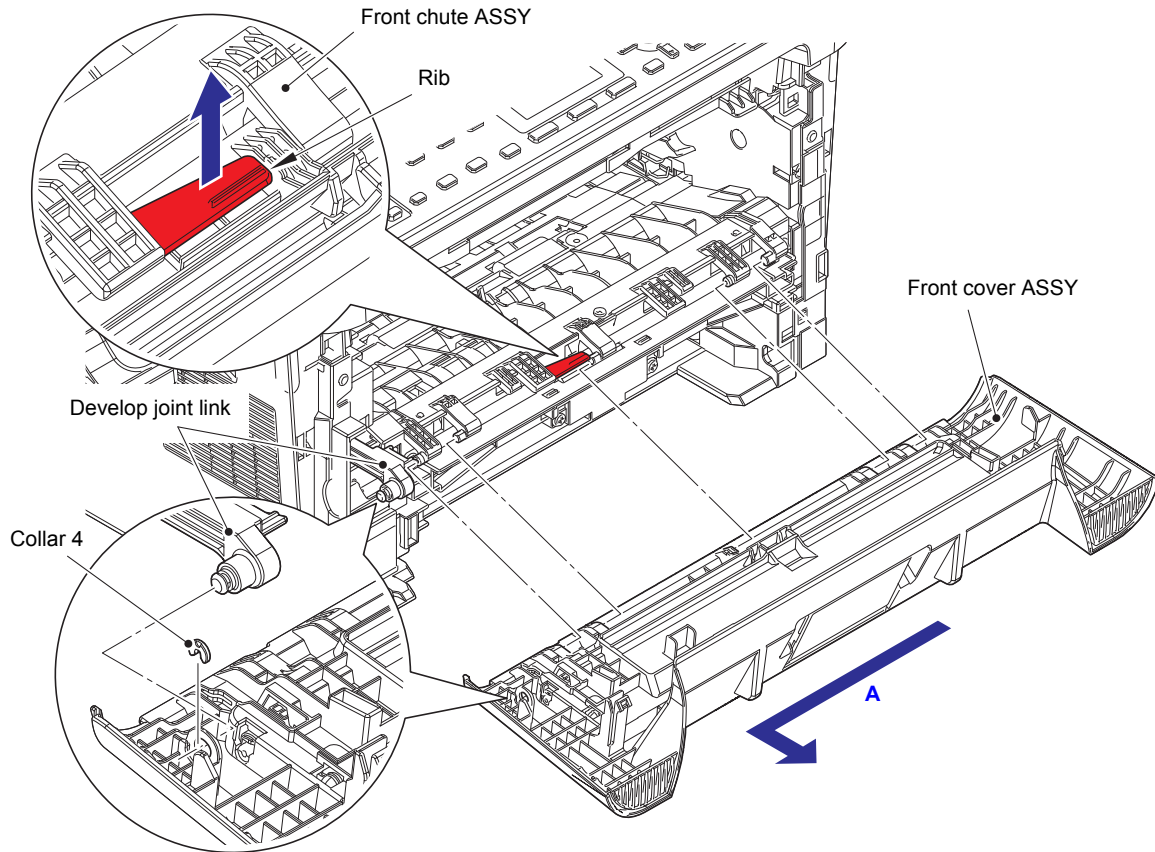
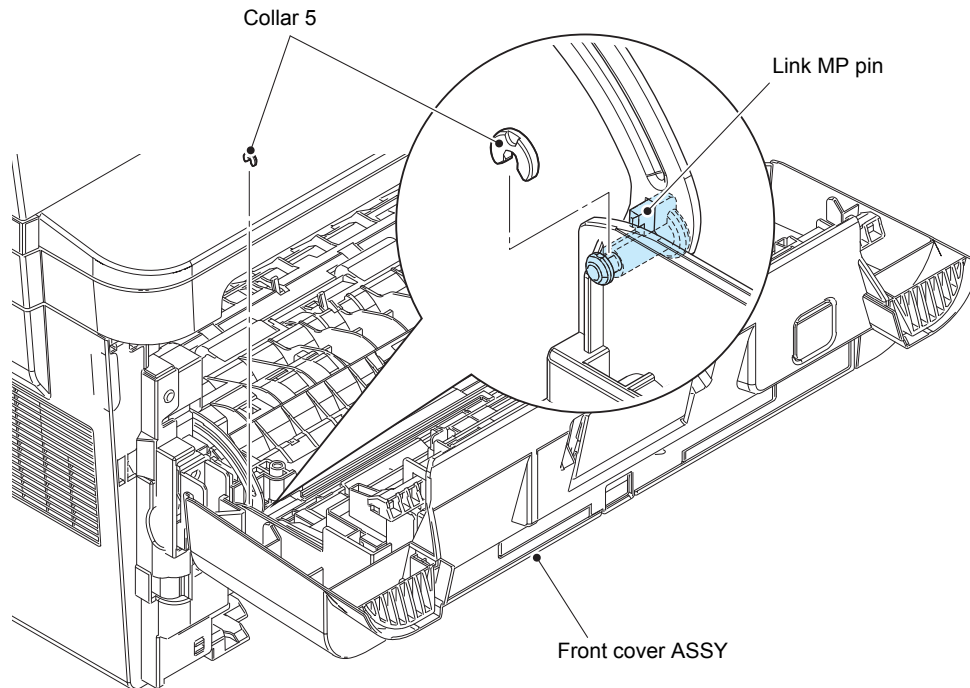


Fig. 3-13

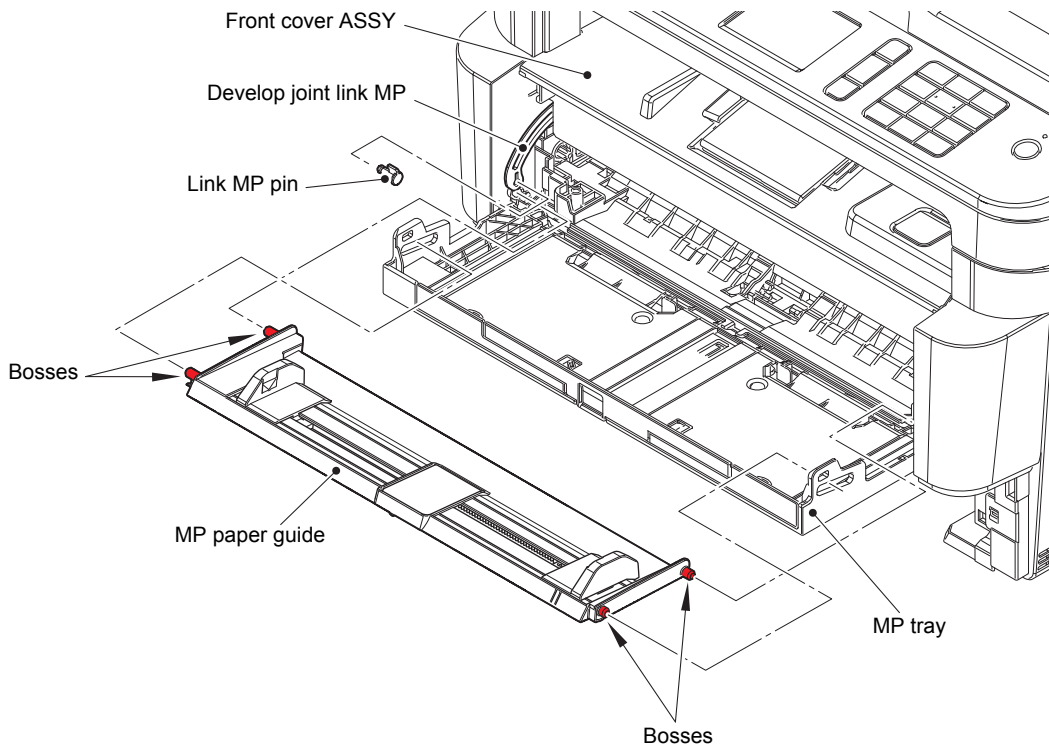
■ **MP models**

- (4) Open the Front cover ASSY. Remove the Collar 5 from the Link MP pin.



**Fig. 3-14**

- (5) Close the Front cover ASSY. Open the MP tray, and release each Boss and remove the MP paper guide from the MP tray.  
(6) Pull out the Link MP pin to remove the Develop joint link MP from the Front cover ASSY.



**Fig. 3-15**

(7) Open the Front cover ASSY. Release each Boss and remove the Front cover ASSY.

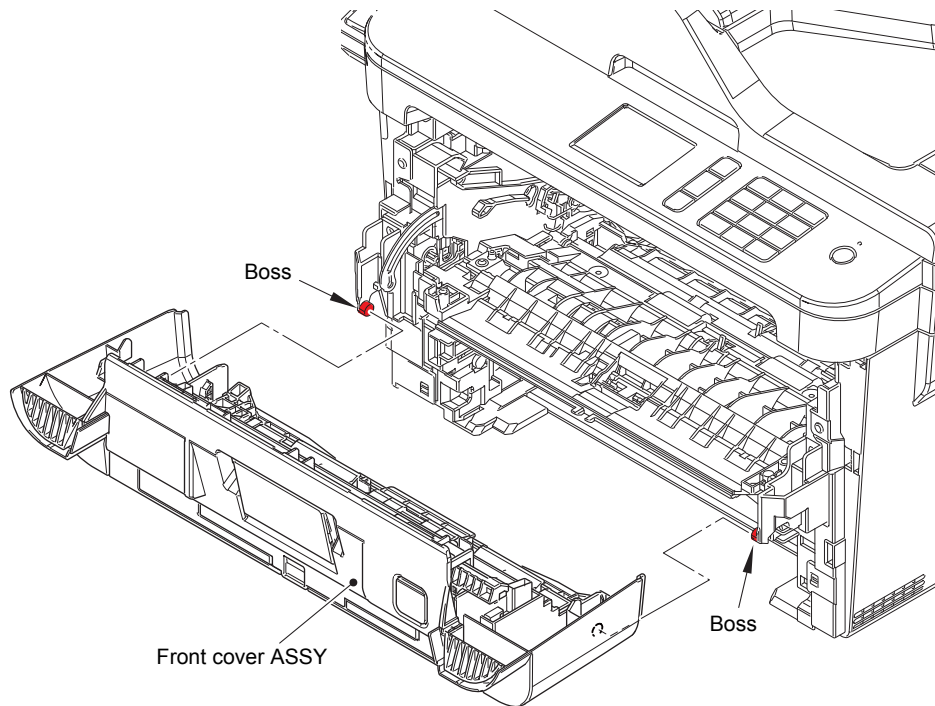


Fig. 3-16

■ **Common to all models**

(8) Remove the Support flap from the Front cover ASSY.

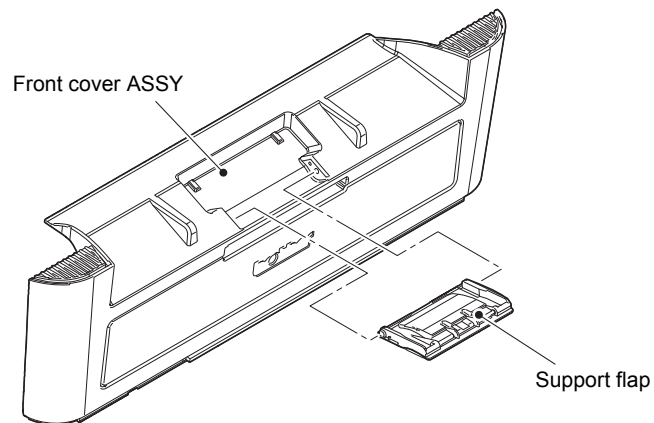


Fig. 3-17



# 9.6 Side cover R

- (1) Remove the Taptite bind B M4x12 screw.
- (2) Release the Hooks A, B, and the Hook C on the Side cover R in order of the arrow A to C, and remove the Side cover R.

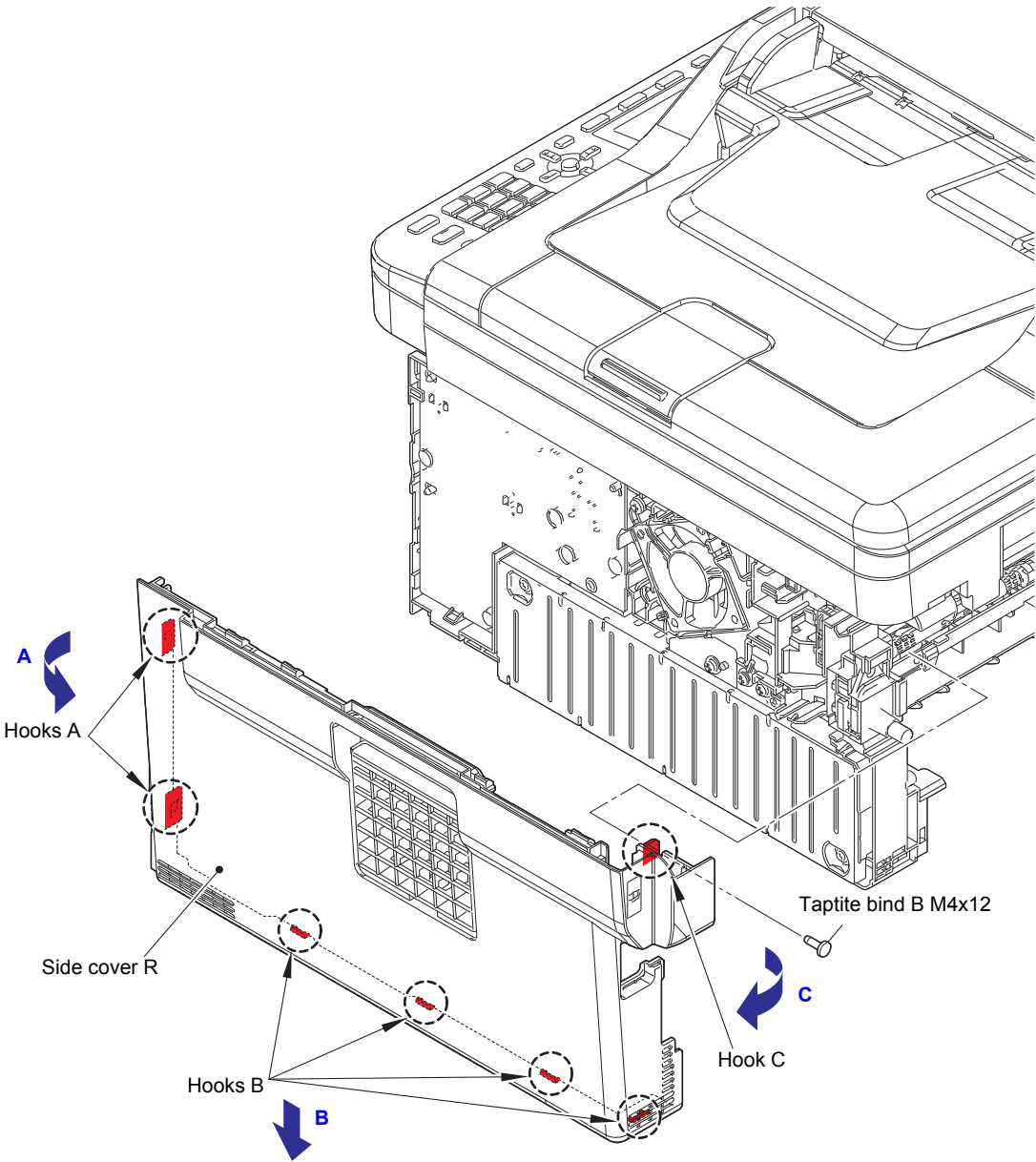


Fig. 3-18



# 9.7 Fuser cover

- (1) Hold the Knobs on the Fuser cover, and pull the Fuser cover down.
- (2) Pull the Fuser cover in the direction of the arrow to remove it from the Bosses, and remove the Fuser cover.

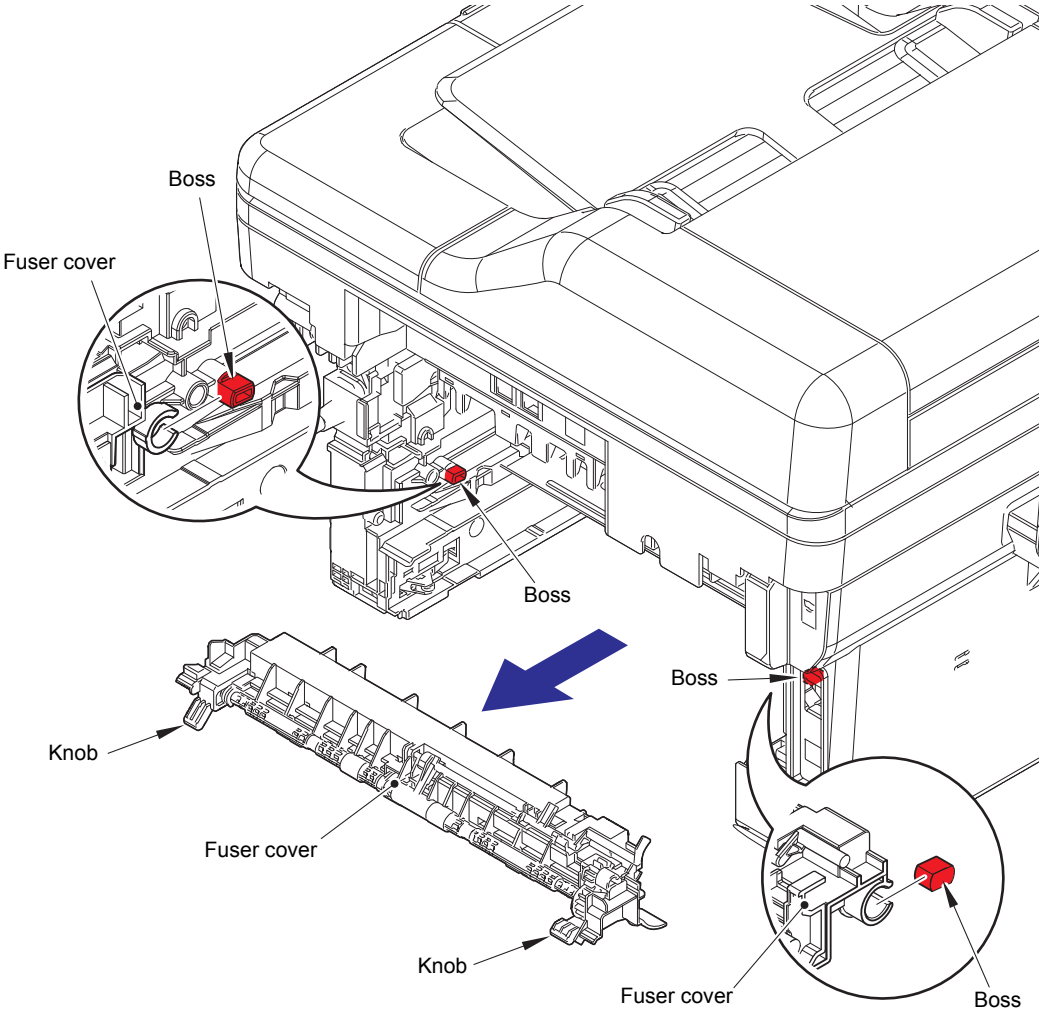


Fig. 3-19

## 9.8 Inner chute ASSY

- (1) Pull down the Green envelope levers on both sides of the Fuser unit.
- (2) Remove the two Taptite bind B M4x12 screws, and remove the Inner chute ASSY.

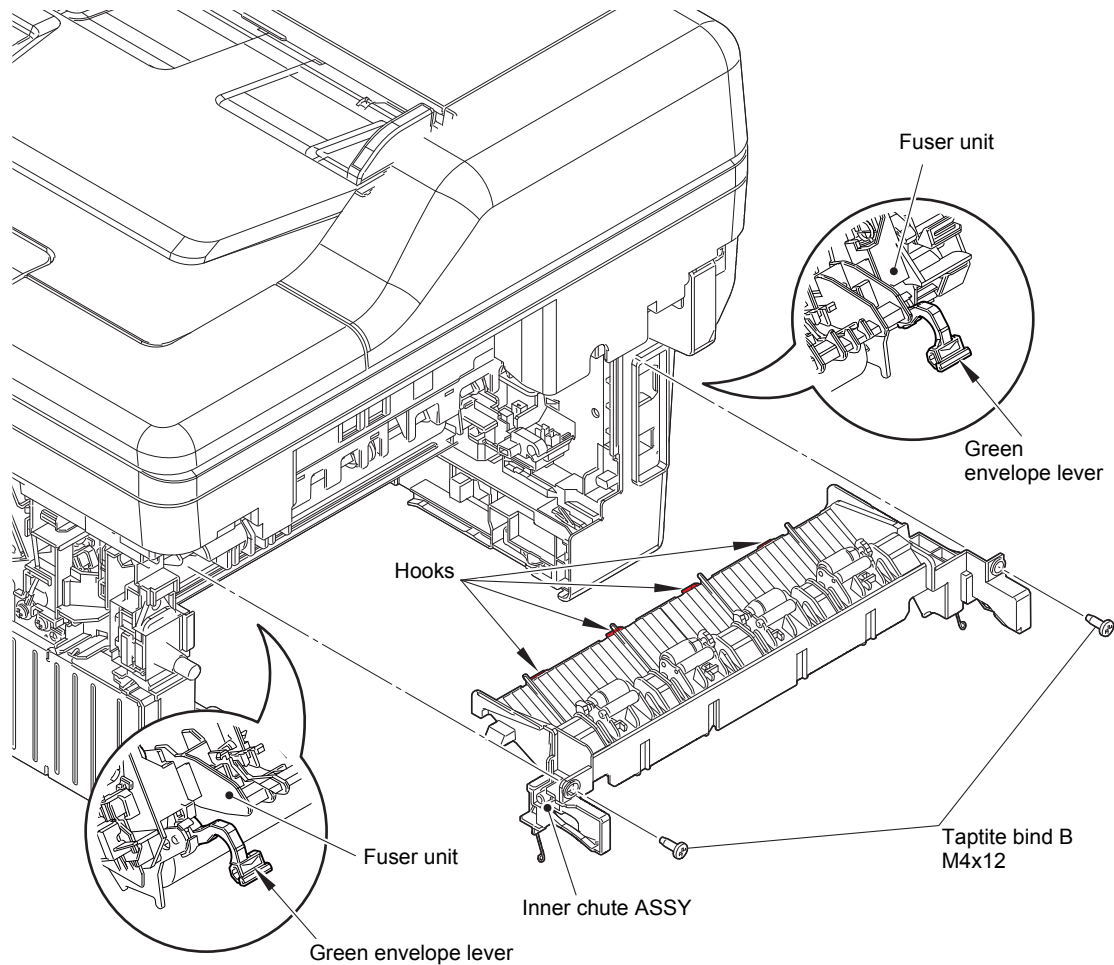


Fig. 3-20

### Assembling Note:

- When attaching the Inner chute ASSY, engage the Hooks on the Inner chute ASSY with the Positioning holes on the Joint cover ASSY.
- After assembling the Inner chute ASSY, pull up the Green envelope levers on both sides of the Fuser unit.

## 9.9 Side cover L / Speaker harness ASSY / Handset holder ASSY (For models with Handset)

- (1) Remove the Taptite bind B M4x12 screw.
- (2) Release the Hooks A, B, and the Hook C on the Side cover L in order of the arrow A to C, and remove the Side cover L.

**Note:**

- When removing the Side cover L, DO NOT pull the Side cover L strongly because it is connected to the Speaker harness ASSY and the Hook harness (for models with Handset).

- (3) Disconnect the Speaker harness ASSY from the Main PCB ASSY.
- (4) Disconnect the Hook harness from the Main PCB ASSY. (For models with Handset)

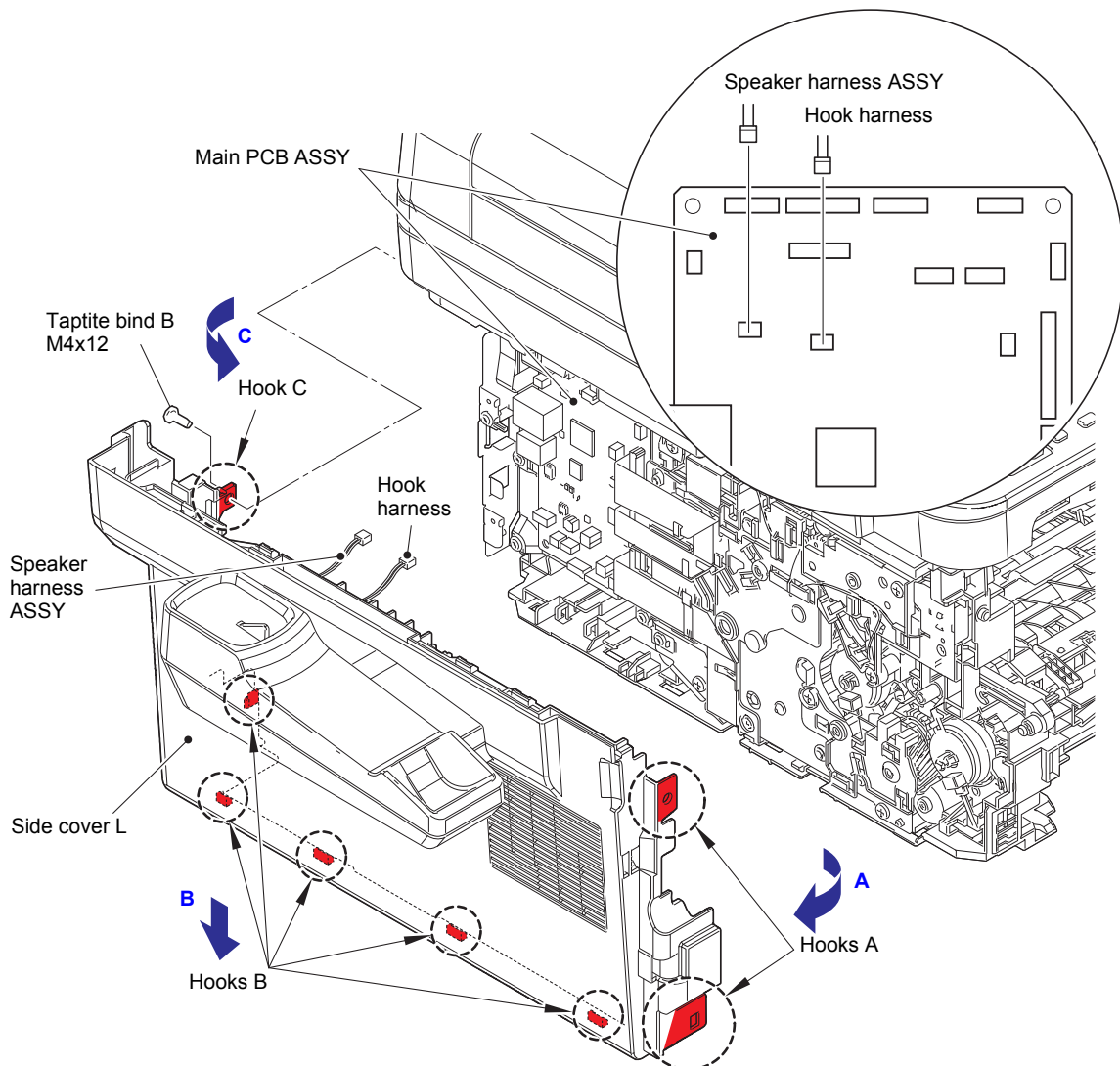
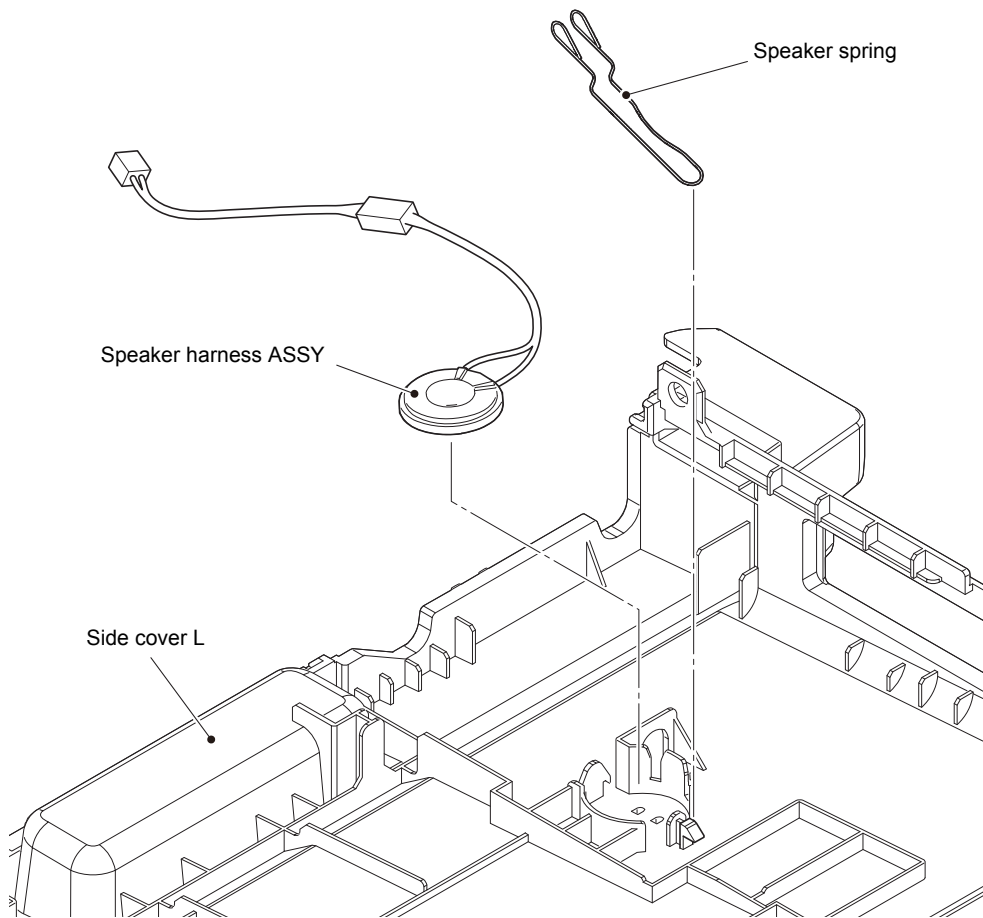


Fig. 3-21

Harness routing: Refer to "1. Handset holder ASSY, Speaker harness ASSY".

- (5) Release the Speaker harness ASSY from the securing fixtures.
- (6) Remove the Speaker spring to remove the Speaker harness ASSY from the Side cover L.

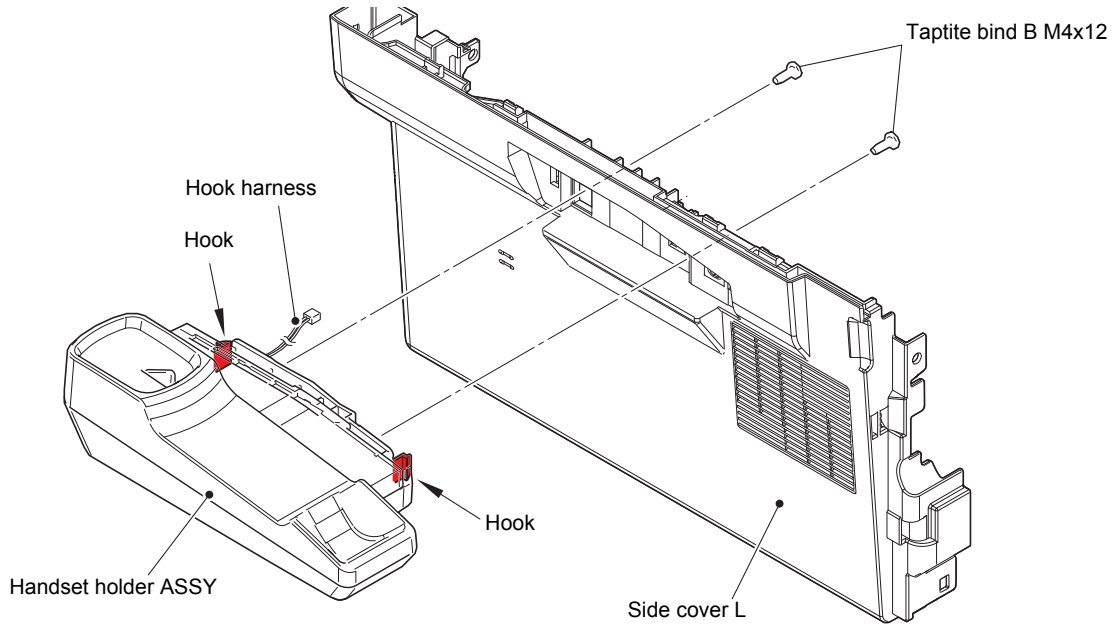


**Fig. 3-22**

Harness routing: Refer to "1. Handset holder ASSY, Speaker harness ASSY".

**<For models with Handset>**

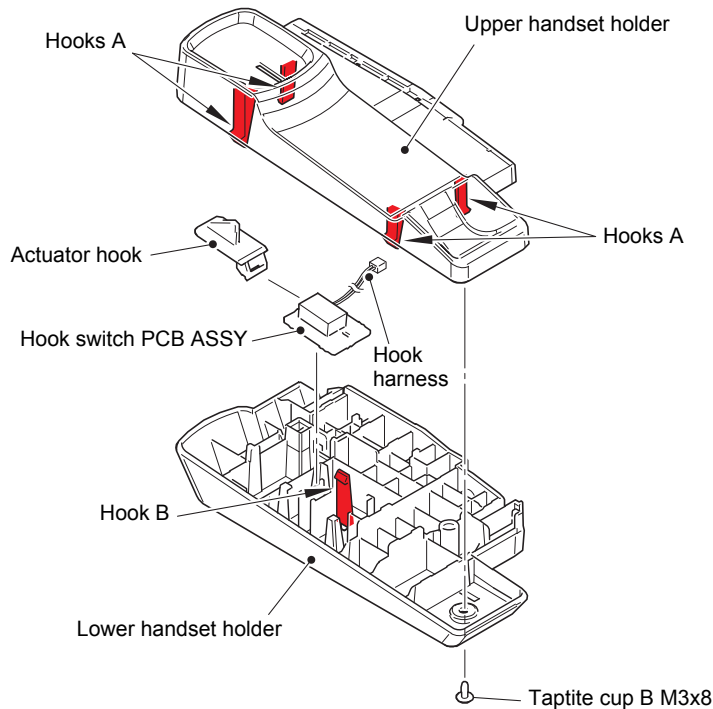
- (7) Remove the two Taptite bind B M4x12 screws. Release each Hook to remove the Handset holder ASSY from the Side cover L. Release the Hook harness from the securing fixtures.



**Fig. 3-23**

Harness routing: Refer to "1. Handset holder ASSY, Speaker harness ASSY".

- (8) Remove the Taptite cup B M3x8 screw. Release each Hook A to remove the Upper handset holder from the Lower handset holder.
- (9) Release the Hook harness from the securing fixtures. Release the Hook B to remove the Hook switch PCB ASSY from the Lower handset holder.
- (10) Remove the Actuator hook from the Hook switch PCB ASSY.



**Fig. 3-24**

Harness routing: Refer to "1. Handset holder ASSY, Speaker harness ASSY".

# 9.10 Document scanner unit

- (1) Open the Document scanner unit.
- (2) Release the Joint parts of Pull arm L and Pull arm R from each Pull arm hinge. Remove the Pull arm L and the Pull arm R from each Pull arm guide.
- (3) Remove each Pull arm spring from the Pull arm L and the Pull arm R.

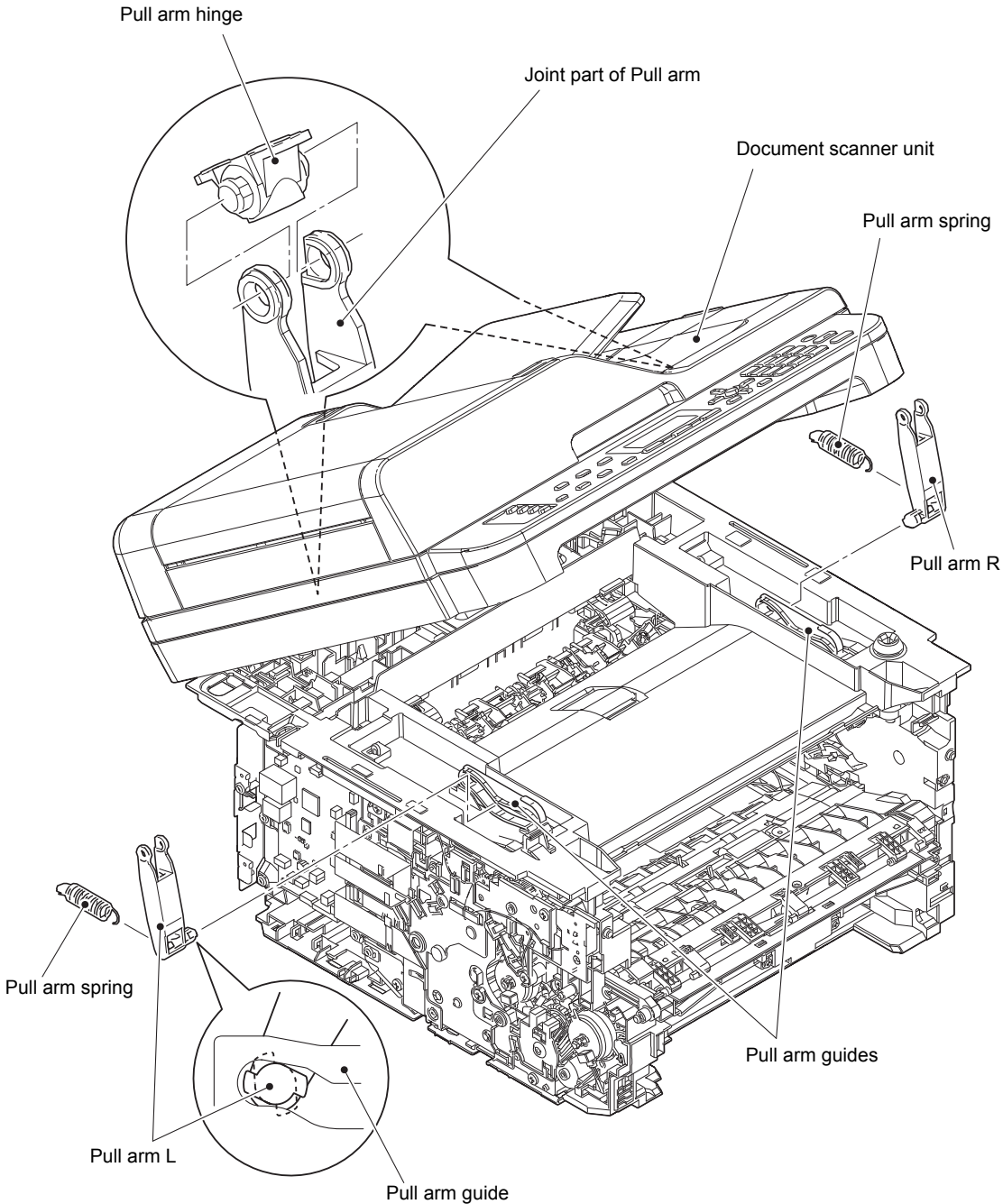
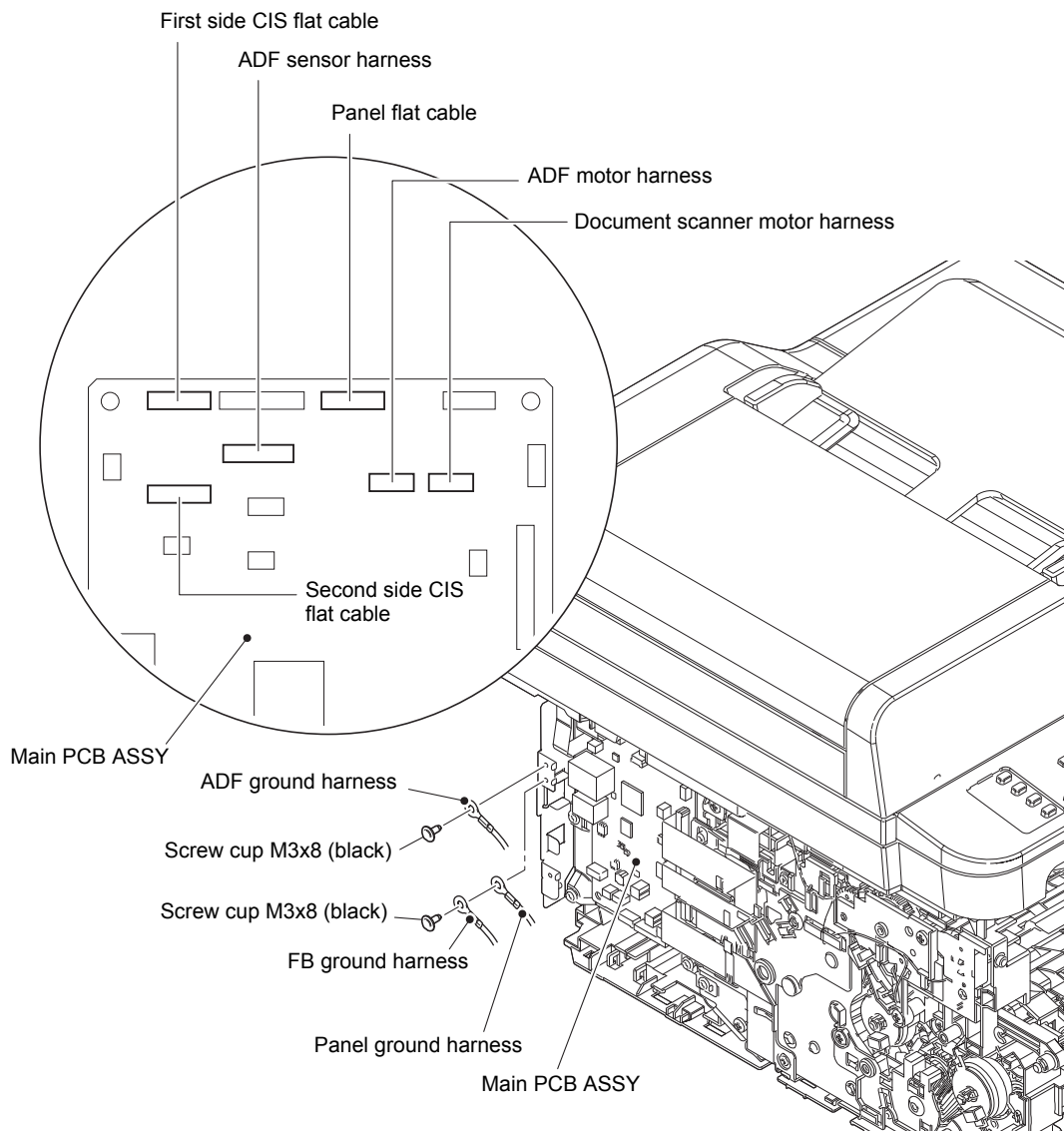


Fig. 3-25

- (4) Remove the Screw cup M3x8 (black) screw to remove the FB ground harness and the Panel ground harness. Disconnect the Document scanner motor harness from the Main PCB ASSY.
- (5) Remove the Screw cup M3x8 (black) screw to remove the ADF ground harness. Disconnect the ADF sensor harness and the ADF motor harness from the Main PCB ASSY.
- (6) Disconnect the First side CIS flat cable, the Panel flat cable, and the Second side CIS flat cable from the Main PCB ASSY.

**Note:**

- After disconnecting flat cables, check that each cable is not damaged at its end or short-circuited.
- When connecting flat cables, do not insert them at an angle. After insertion, check that the cables are not at an angle.



**Fig. 3-26**

Harness routing: Refer to “2. ADF unit”, “3. Document scanner unit”.



- (7) Release the Hook to remove the ADF FFC holder while opening the Document scanner unit.
- (8) Open the Document scanner unit approximately 30 degrees, and remove it by lifting it up. Pull out the Document scanner motor harness and the ADF sensor harness unit from each Hole on the Joint cover.

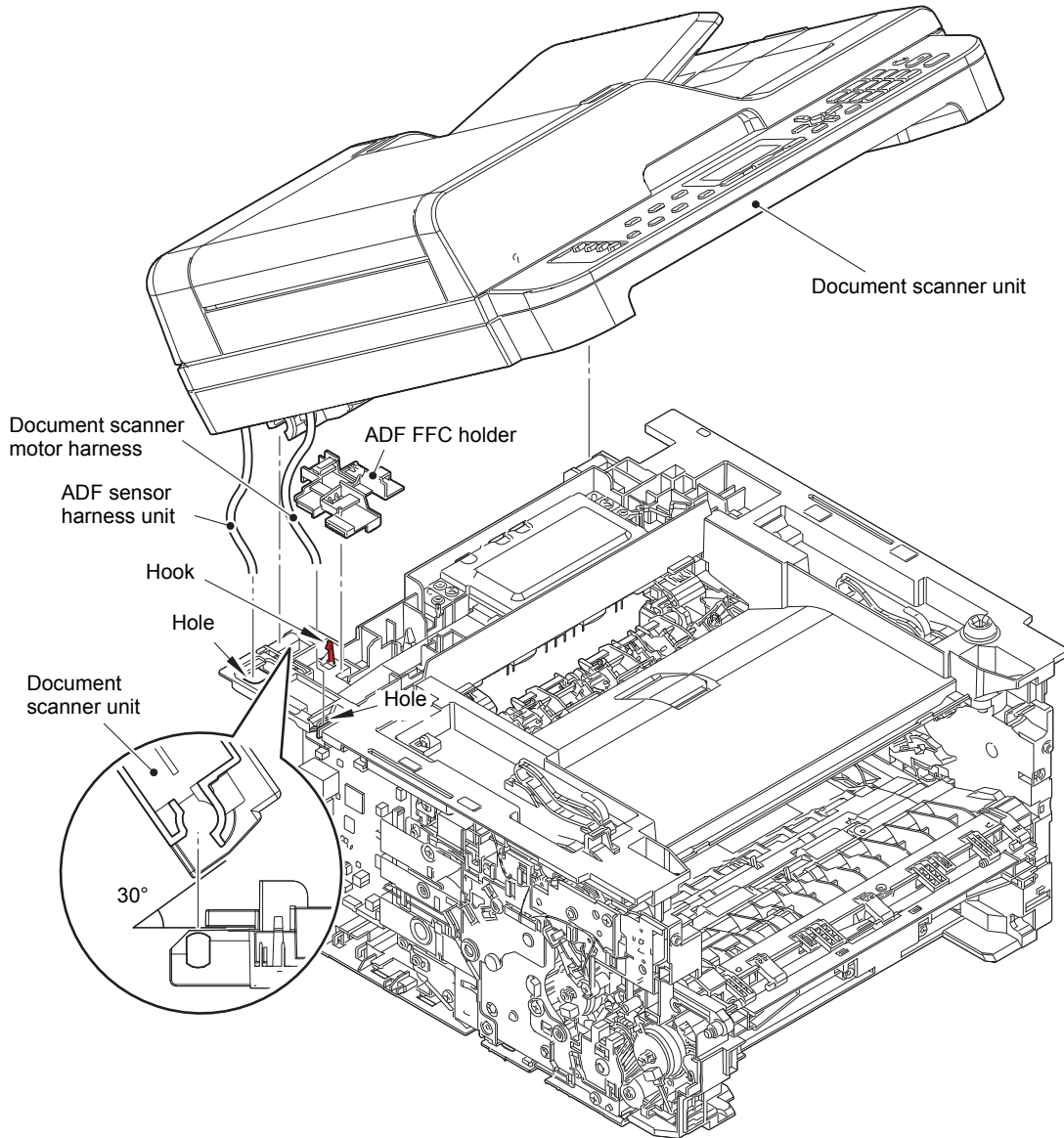


Fig. 3-27

Harness routing: Refer to "2. ADF unit", "3. Document scanner unit".

**Assembling Note:**

- If you replaced the Document scanner unit, refer to "5. IF YOU REPLACE THE ADF UNIT, FIRST SIDE CIS UNIT, SECOND SIDE CIS UNIT OR DOCUMENT SCANNER UNIT" in Chapter 4 to configure settings.



## 9.11 ADF unit (For models with ADF)

### 9.11.1 ADF unit

- (1) Remove the ADF FFC holder from the Panel flat cable, the First side CIS flat cable, and the Second side CIS flat cable.
- (2) Remove the Taptite bind B M4x12 (black) screw from the Hinge ASSY L.

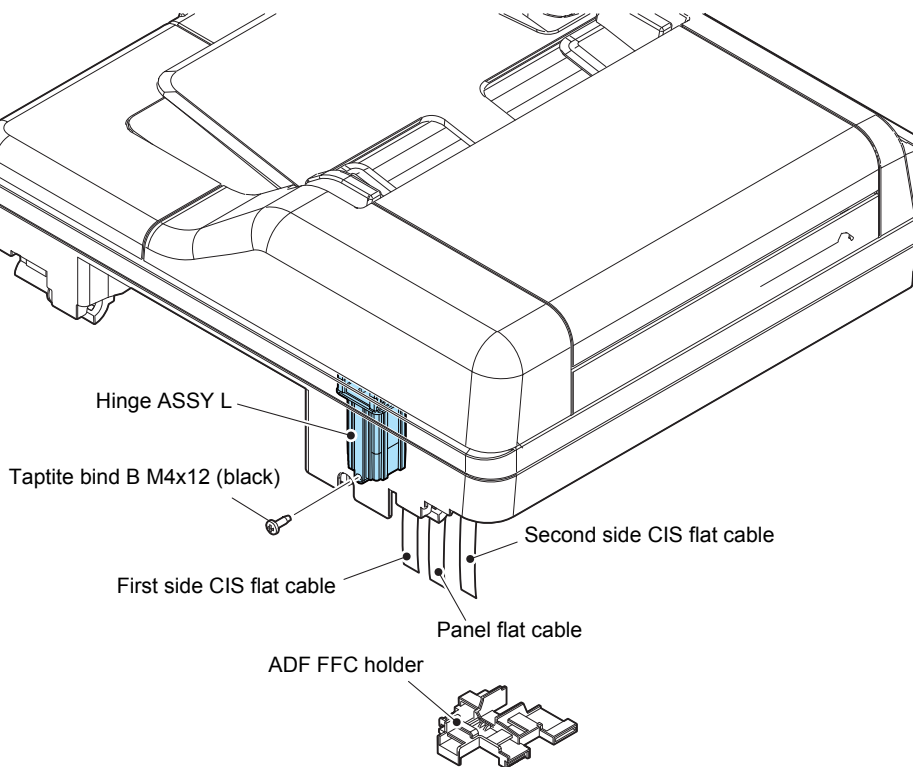


Fig. 3-28

#### Assembling Note:

- Attach the Panel flat cable, the First side CIS flat cable, and the Second side CIS flat cable to the ADF FFC holder as shown in the figure below.

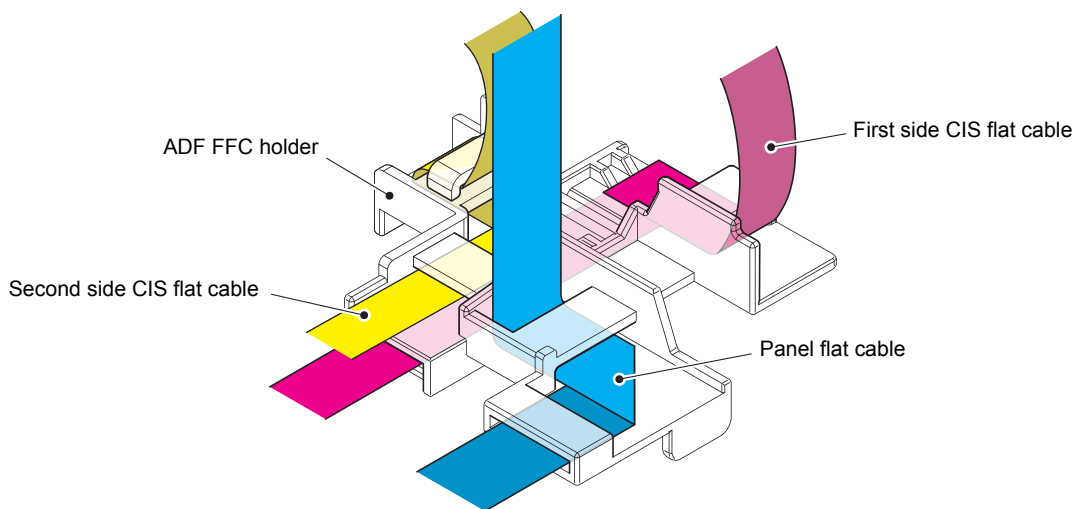


Fig. 3-29

- (3) Open the ADF unit. Release the Hook of the FFC holder ASSY, and remove the FFC holder ASSY from the Document scanner unit.
- (4) Lift the ADF unit, and remove the ADF unit from the Document scanner unit while pushing the Hook of the Hinge R. Pull out the ADF sensor harness unit from the Hole.
- (5) Remove the FFC holder ASSY from the ADF sensor harness unit and the Second side CIS flat cable.

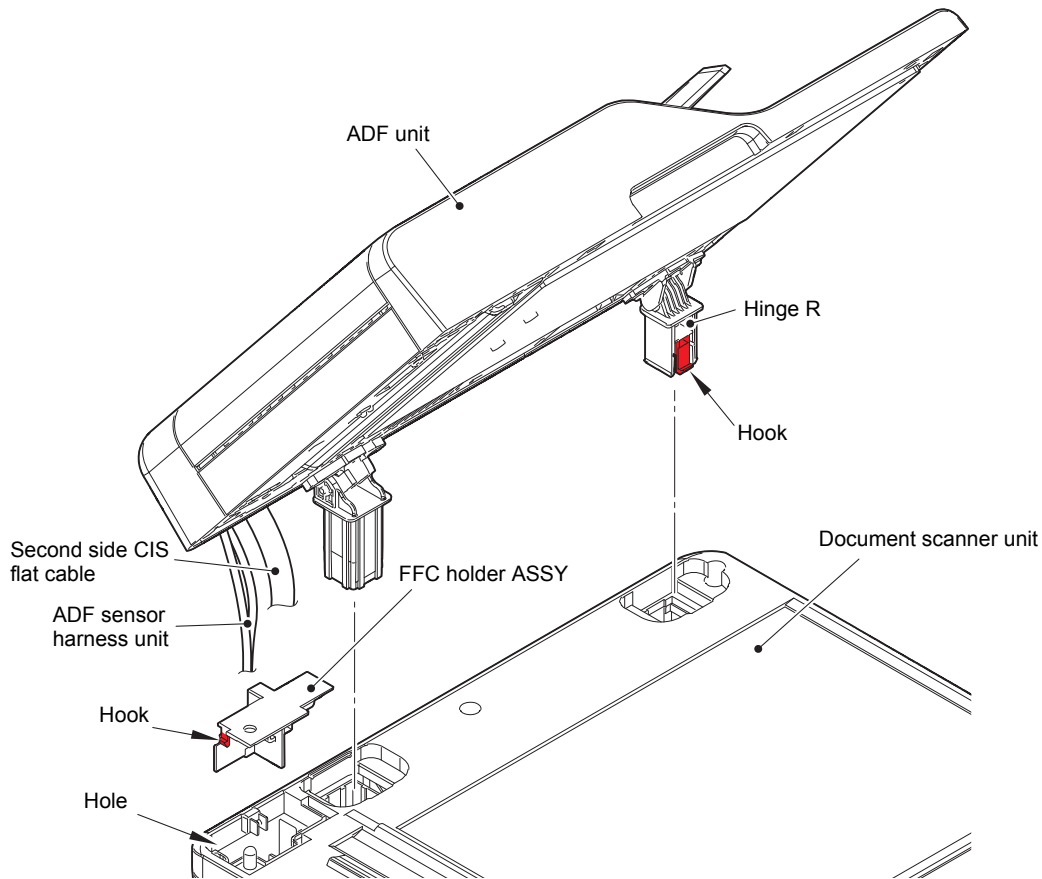


Fig. 3-30

Harness routing: Refer to "2. ADF unit".

**Assembling Note:**

- If you replaced the ADF unit, refer to "5. IF YOU REPLACE THE ADF UNIT, FIRST SIDE CIS UNIT, SECOND SIDE CIS UNIT OR DOCUMENT SCANNER UNIT" in Chapter 4 to configure settings.
- Attach the FFC holder ASSY to the ADF sensor harness unit and the Second side CIS flat cable as shown in the figure below.

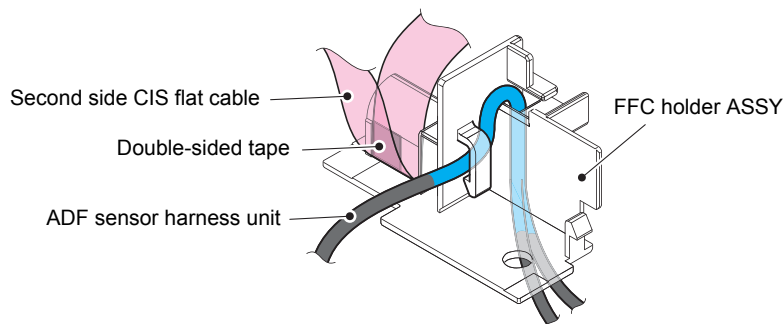
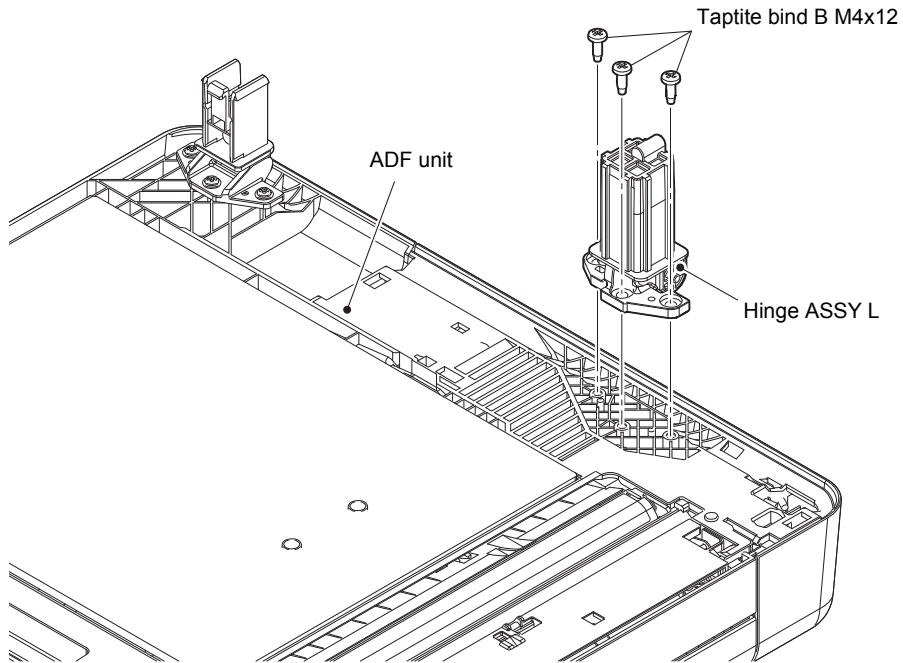


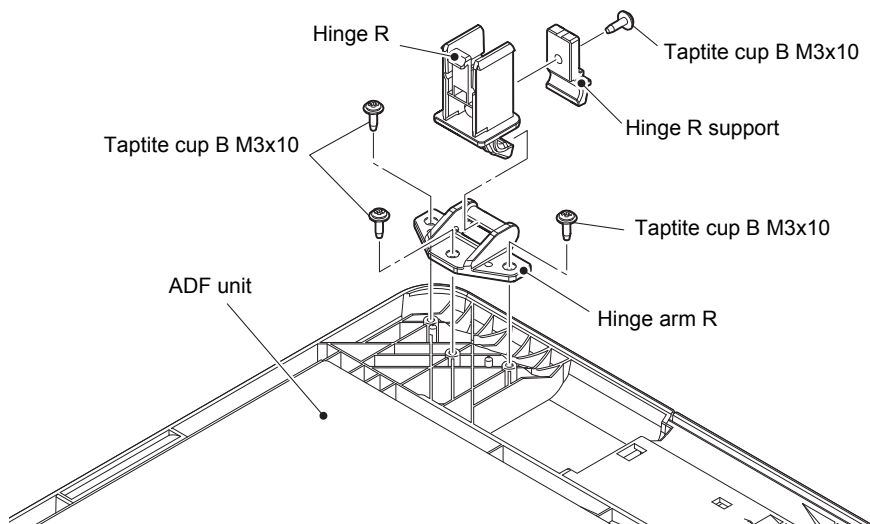
Fig. 3-31

- (6) Remove the three Taptite bind B M4x12 screws to remove the Hinge ASSY L from the ADF unit.



**Fig. 3-32**

- (7) Remove the Taptite cup B M3x10 screw to remove the Hinge R support and the Hinge R from the Hinge arm R.
- (8) Remove the three Taptite cup B M3x10 screws to remove the Hinge arm R from the ADF unit.



**Fig. 3-33**

### 9.11.2 ADF cover ASSY / Document stopper

- (1) Open the ADF cover ASSY. Release the two Bosses to remove the ADF cover ASSY from the ADF unit.
- (2) Release the two Bosses to remove the Document stopper from the ADF unit.

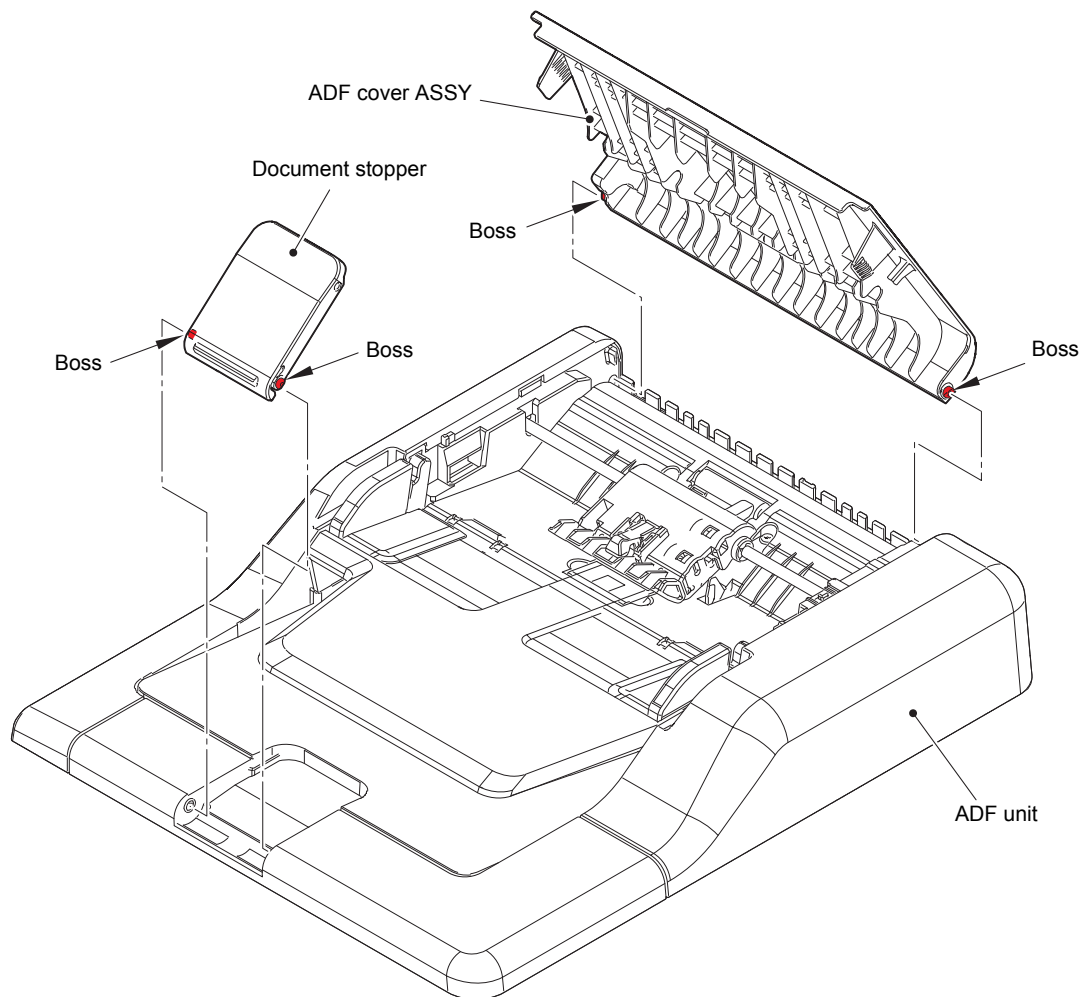


Fig. 3-34

### 9.11.3 Document sub tray

- (1) Release each Hook to remove the Gear cover from the ADF unit.
- (2) Remove the two Taptite cup B M3x10 screws. Release each Hook to remove the ADF front cover from the ADF unit.

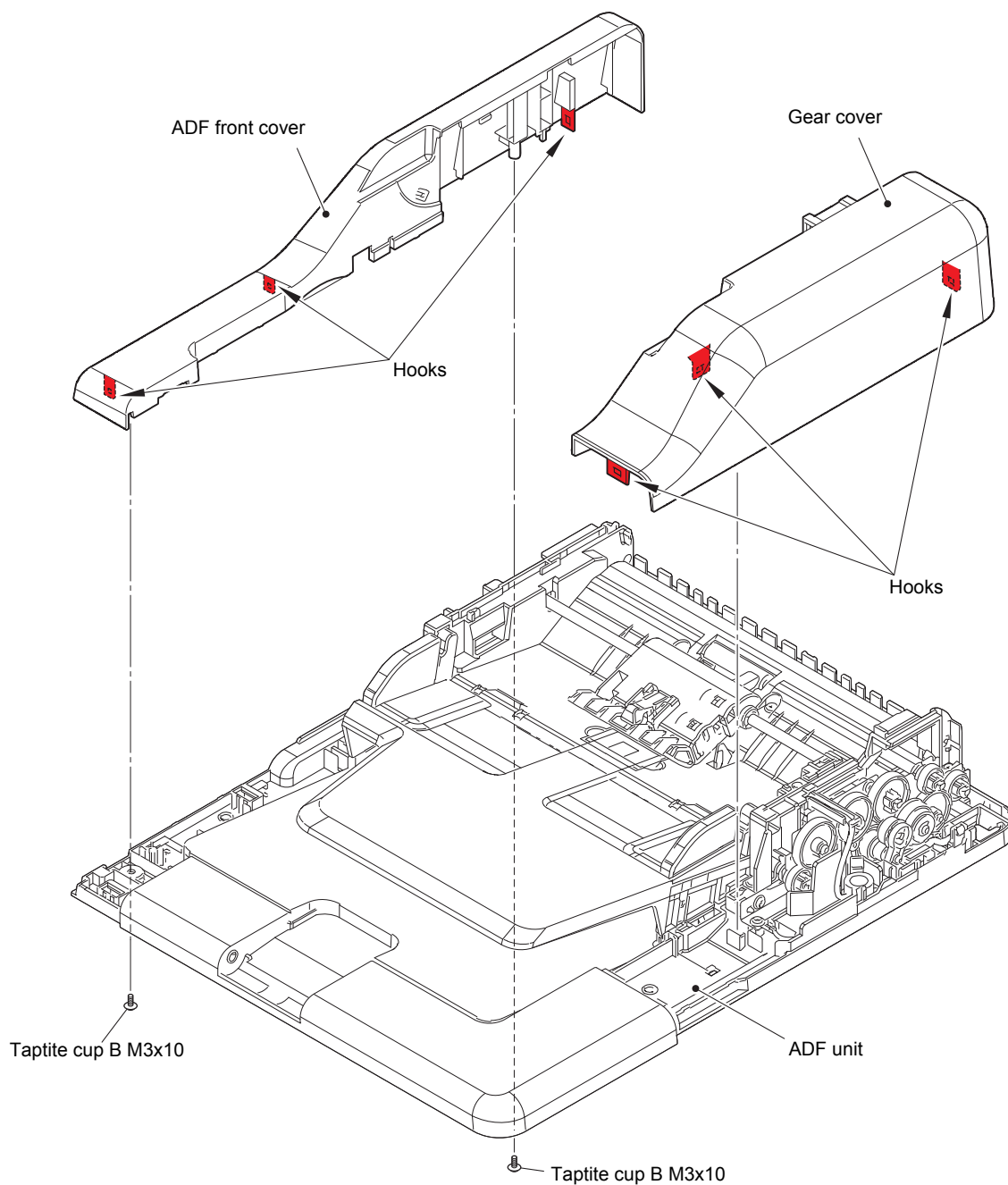
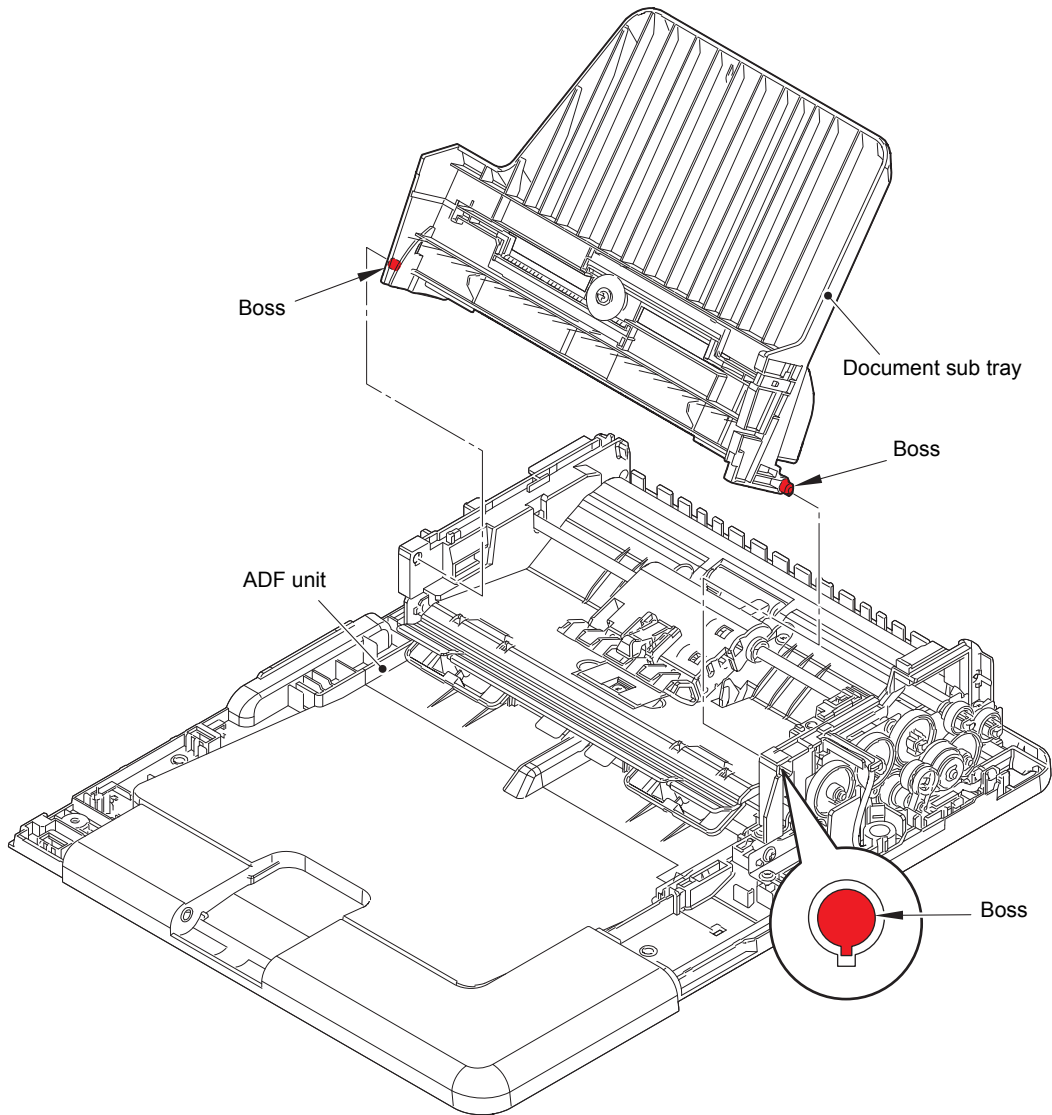


Fig. 3-35

(3) Open the Document sub tray to remove it from the ADF unit by aligning each Boss position.



**Fig. 3-36**

### 9.11.4 Document separate roller ASSY

- (1) Release the Lock of the Conductive bushing to remove the Document separate roller ASSY from the ADF unit.

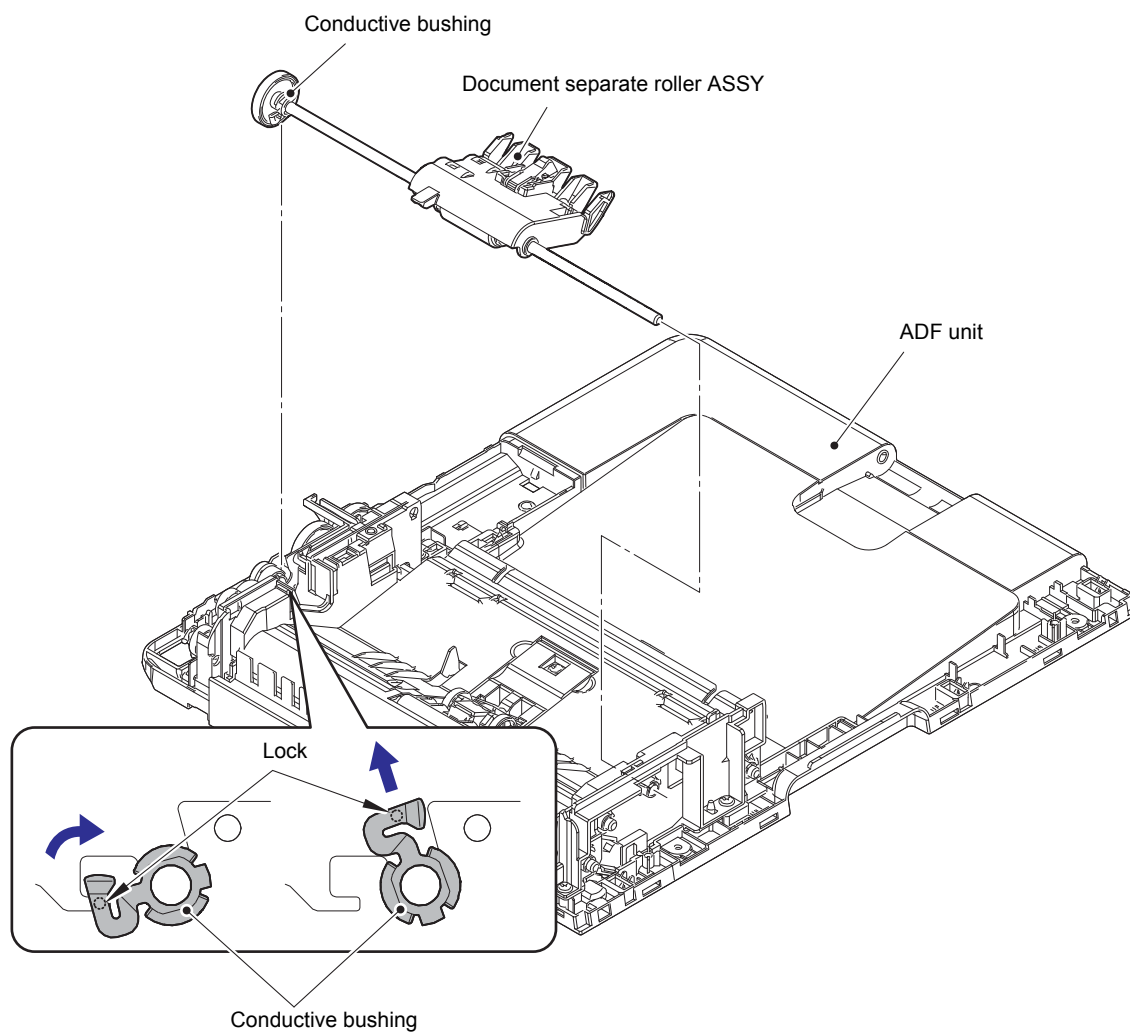


Fig. 3-37

### 9.11.5 ADF separation holder ASSY

- (1) Remove the Taptite cup B M3x10 screw to remove the ADF separation holder ASSY from the ADF unit.

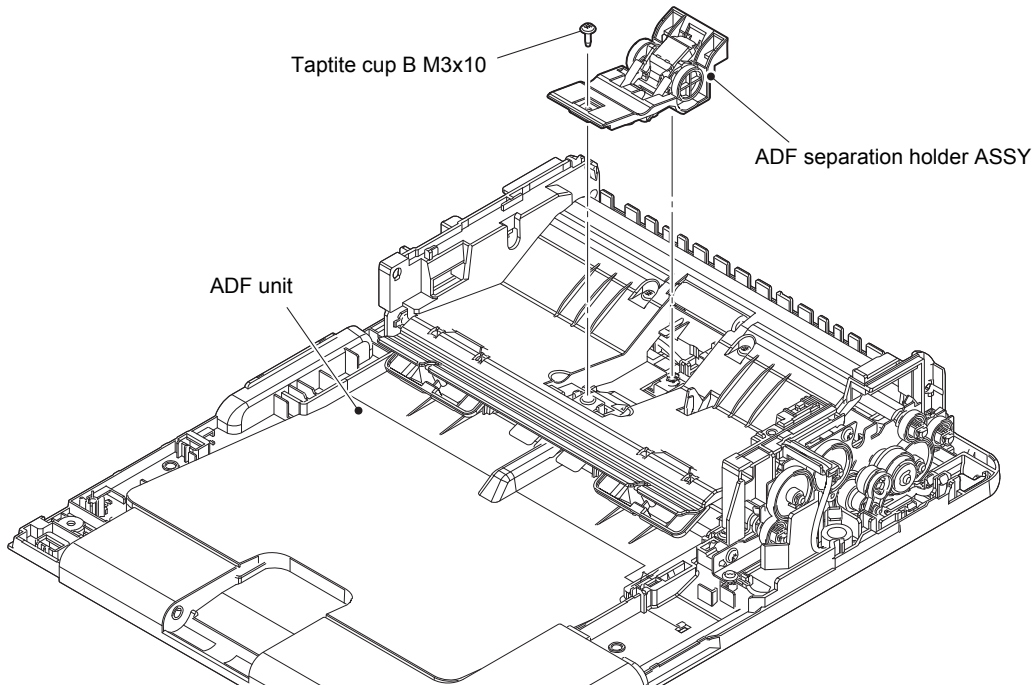


Fig. 3-38



### 9.11.6 Second side CIS unit / Second side CIS flat cable

(Only for models with duplex scanning)

- (1) Remove the six Taptite cup B M3x10 screws to remove the Upper document chute from the ADF unit.

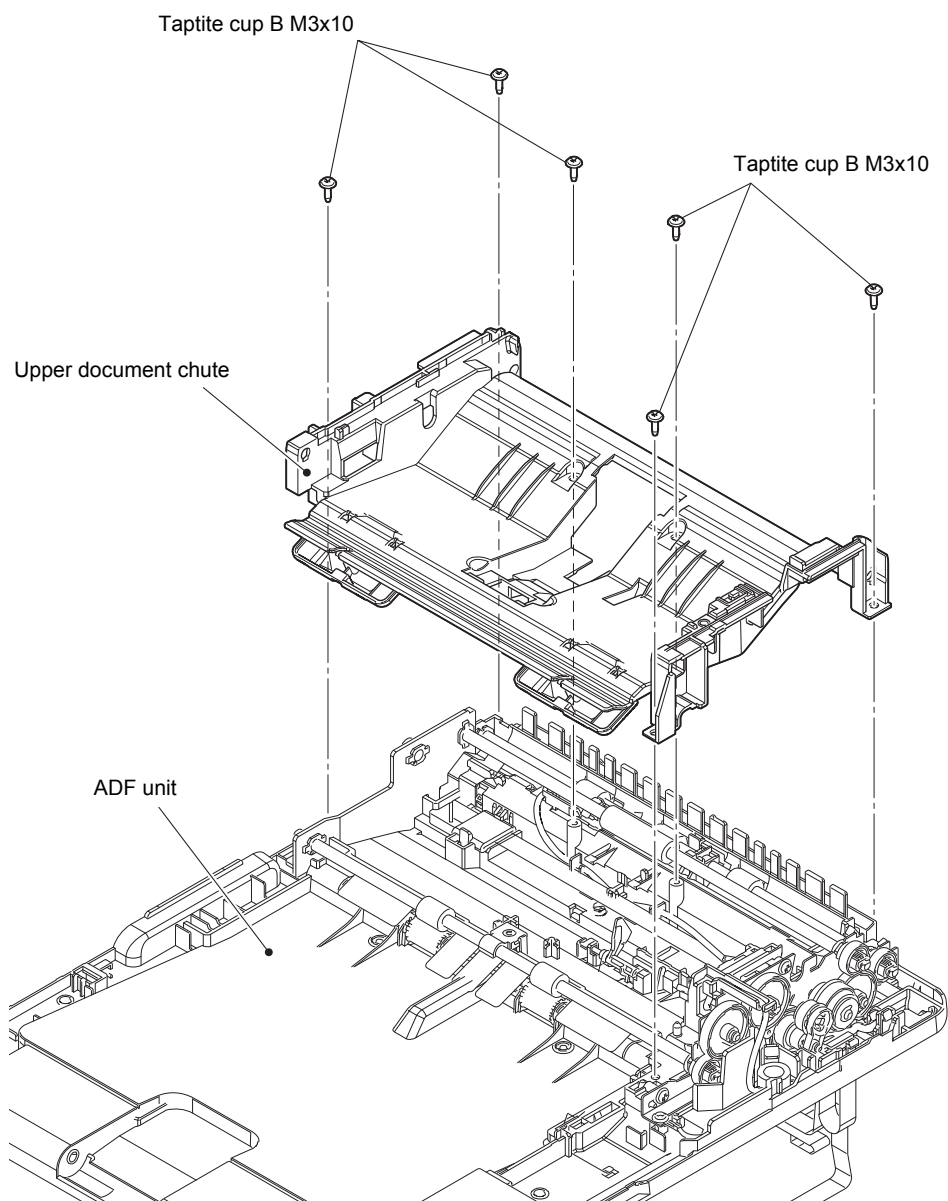
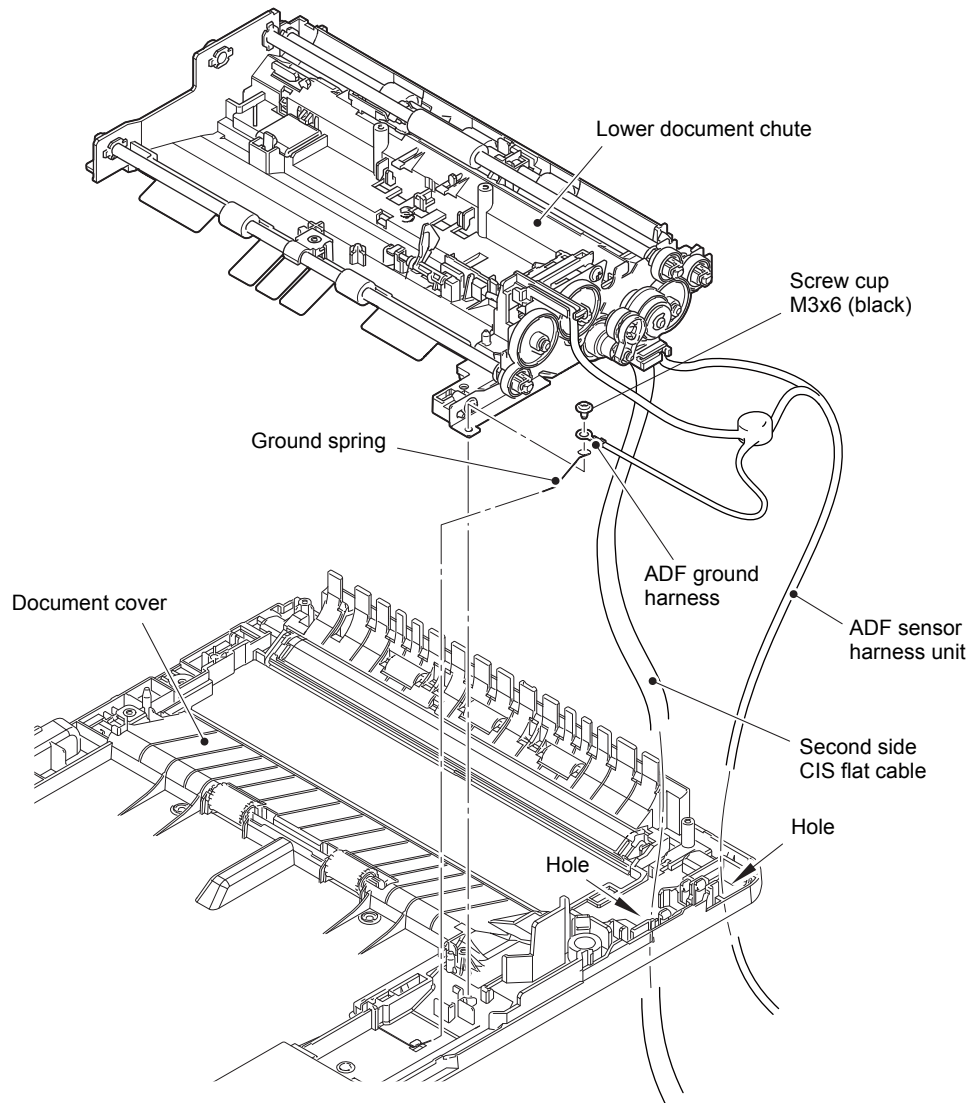


Fig. 3-39

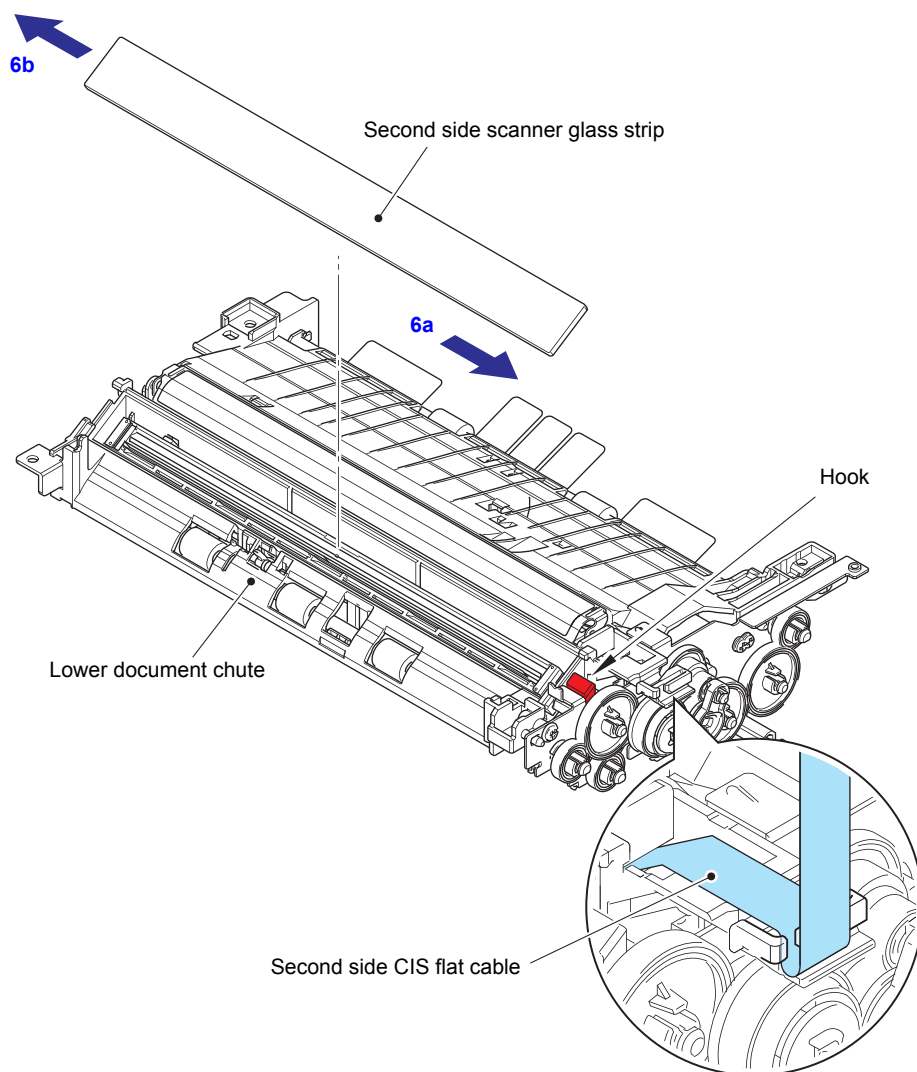
- (2) Remove the Screw cup M3x6 (black) screw to remove the ADF ground harness and the Ground spring from the Lower document chute.
- (3) Release the ADF sensor harness unit from the securing fixtures, and pull it out from the Hole of the Document cover.
- (4) Remove the Lower document chute from the Document cover, and pull out the Second side CIS flat cable from the Hole of the Document cover.



**Fig. 3-40**

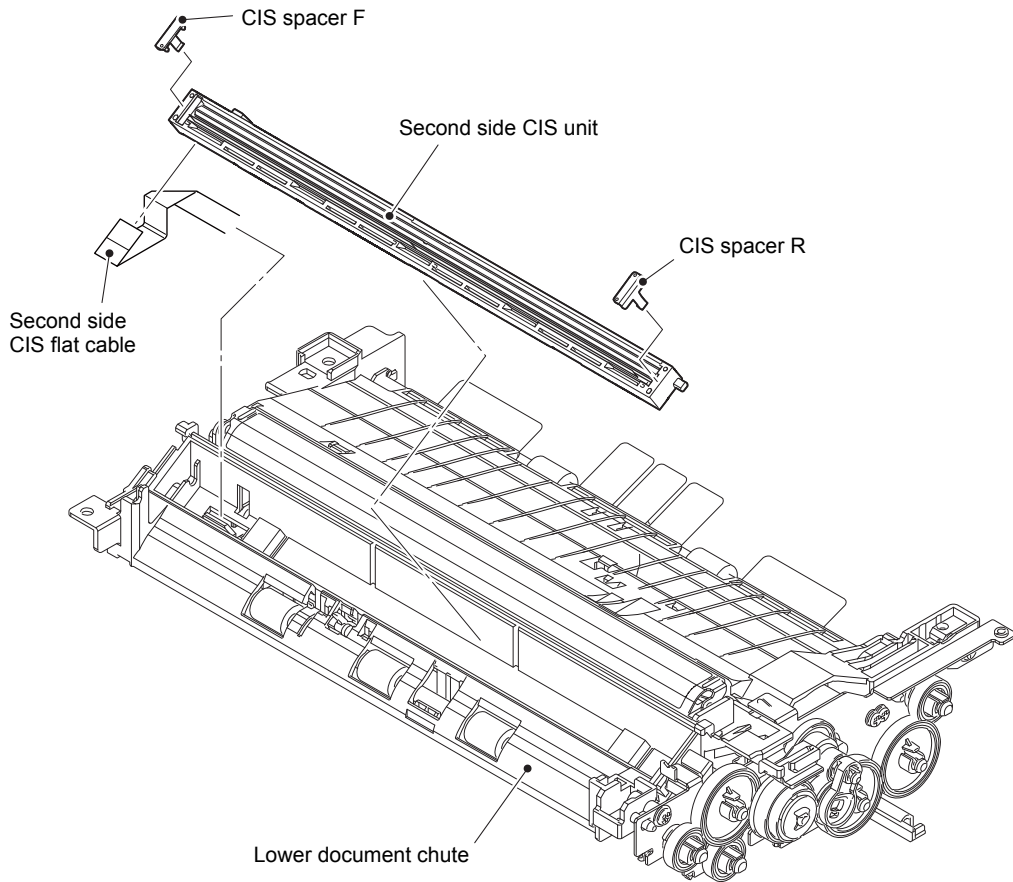
Harness routing: Refer to "2. ADF unit".

- (5) Release the Second side CIS flat cable from the securing fixtures.
- (6) Lift the Hook and slide the Second side scanner glass strip in the direction of the arrow 6a. Lift the left end of the Second side scanner glass strip to remove it in the direction of the arrow 6b.



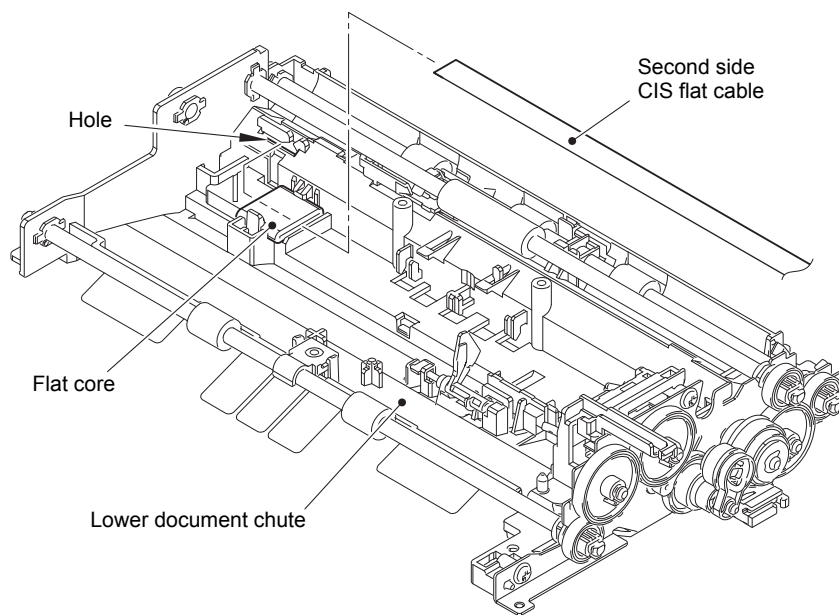
**Fig. 3-41**

- (7) Remove the Second side CIS unit from the Lower document chute, and disconnect the Second side CIS flat cable from the Second side CIS unit.
- (8) Remove the CIS spacer F and the CIS spacer R from the Second side CIS unit.



**Fig. 3-42**

- (9) Pull out the Second side CIS flat cable from the Hole and the Flat core, and remove it from the Lower document chute.

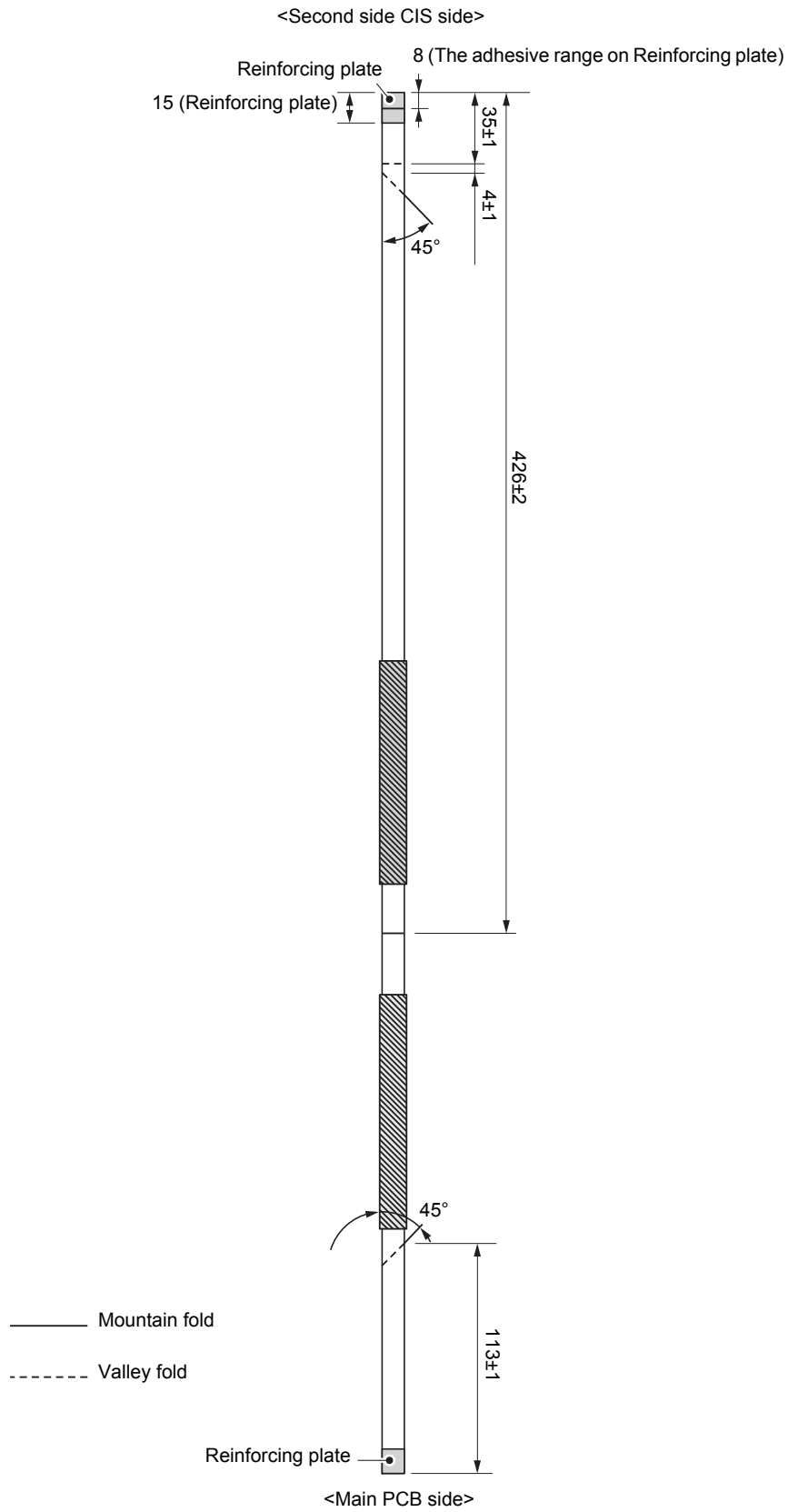


**Fig. 3-43**

Harness routing: Refer to "4. Lower document chute".

**Assembling Note:**

- Fold the Second side CIS flat cable at the positions described below.



**Fig. 3-44**

# 9.12 Document cover ASSY (For models without ADF)

- (1) Release the Hooks of the Hinge L and the Hinge R to remove the Document cover ASSY by lifting it up.

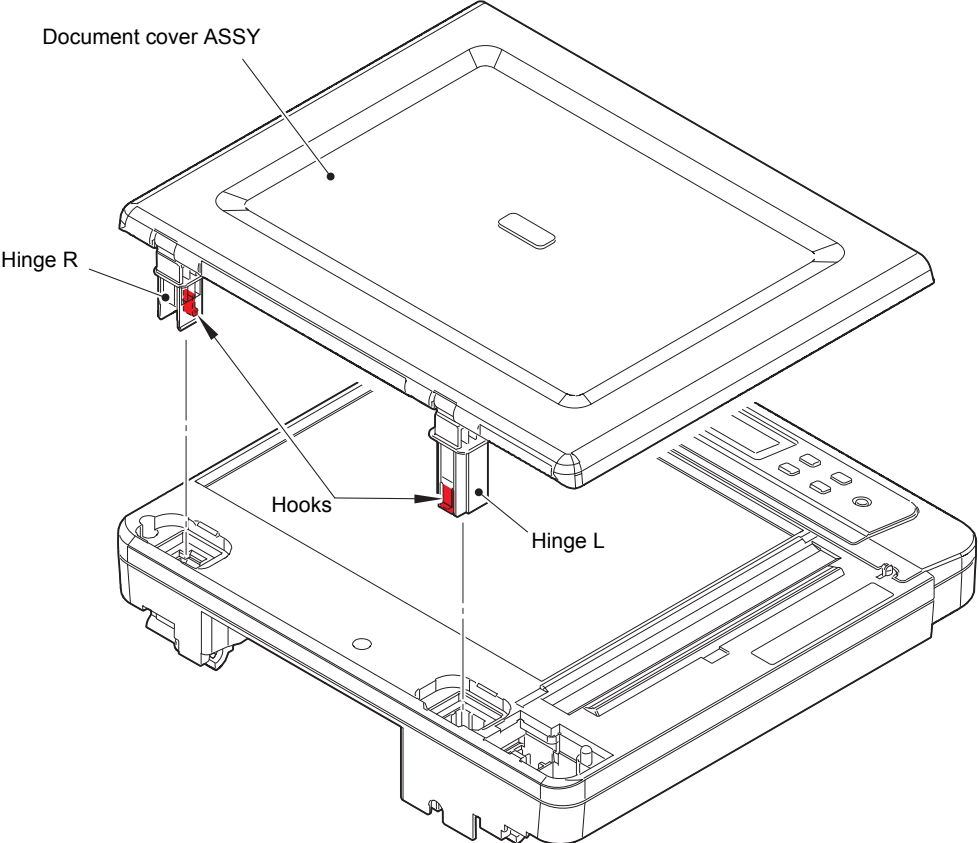
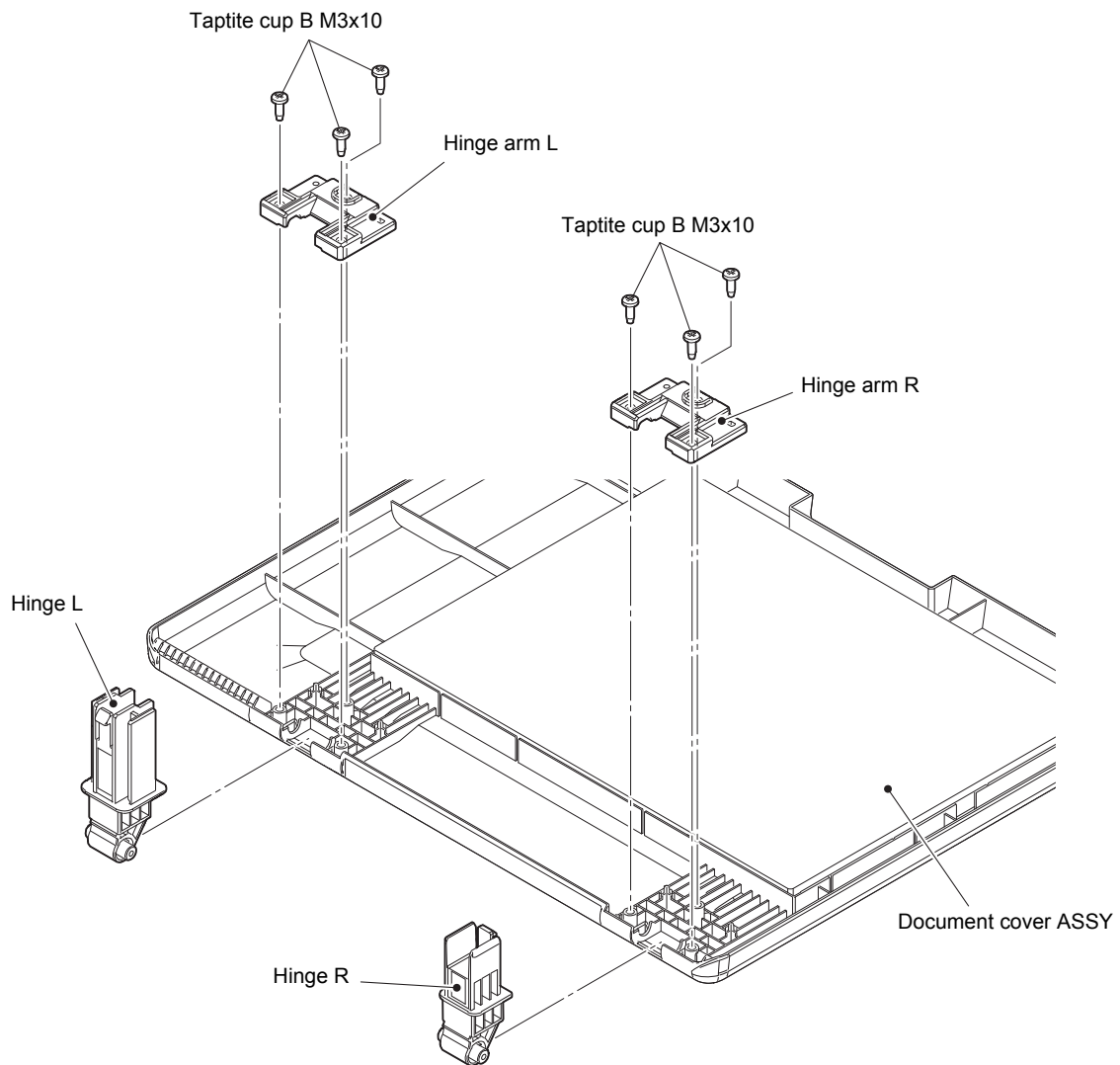


Fig. 3-45

- (2) Remove the three Taptite cup B M3x10 screws to remove the Hinge arm L and the Hinge L from the Document cover ASSY.
- (3) Remove the three Taptite cup B M3x10 screws to remove the Hinge arm R and the Hinge R from the Document cover ASSY.



**Fig. 3-46**

## 9.13 Panel unit (For Touch panel models)

### 9.13.1 Panel unit

- (1) Remove the four Taptite cup B M3x10 screws.
- (2) Release each Hook to remove the Panel unit. Disconnect the Panel flat cable from the Panel PCB ASSY.

**Note:**

- When removing the Panel unit, DO NOT pull the Panel unit strongly because it is connected to the Panel flat cable.

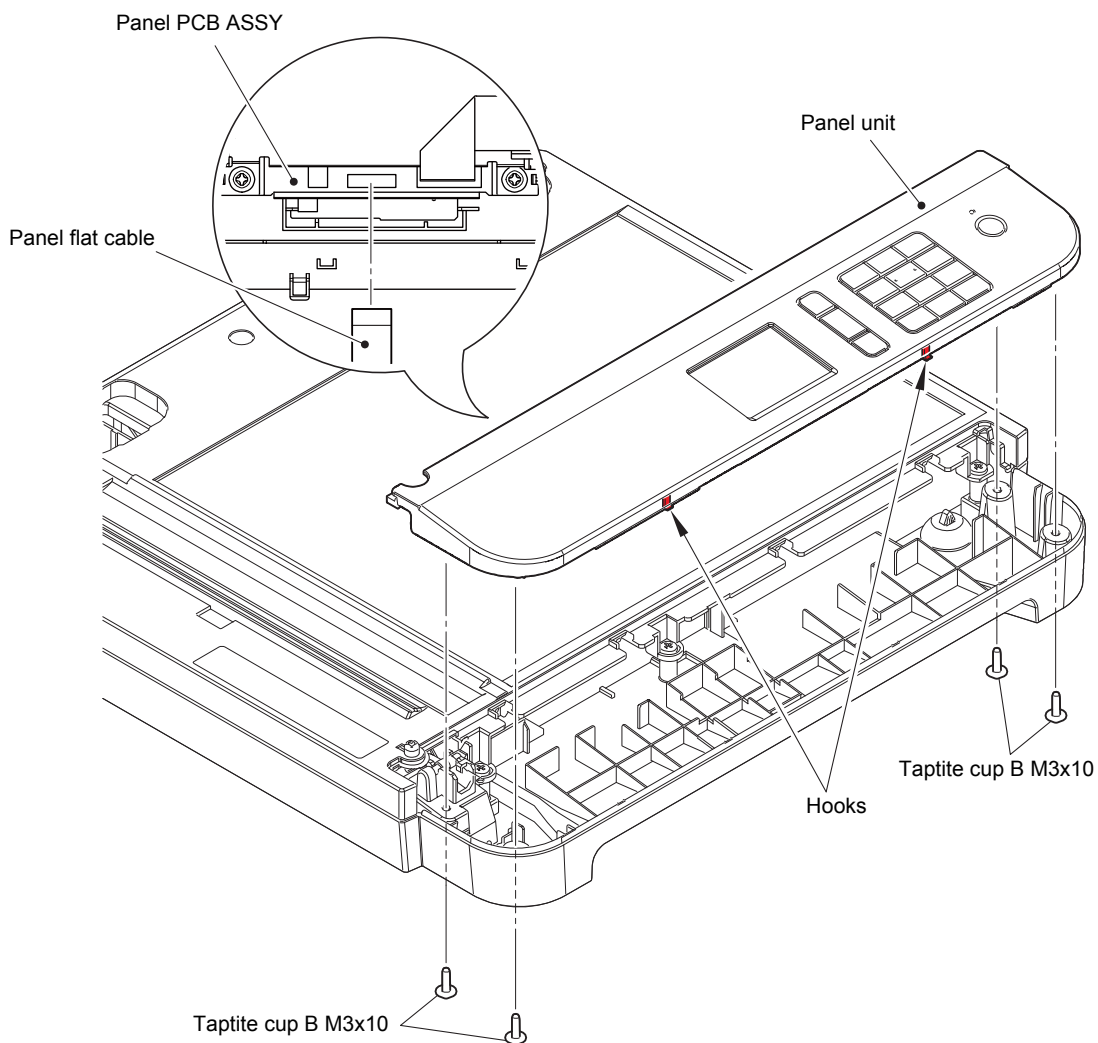


Fig. 3-47

Harness routing: Refer to "3. Document scanner unit".

**Assembling Note:**

- If you replaced the Panel unit, refer to "4. IF YOU REPLACE THE PANEL UNIT OR PANEL CONTROL PCB" in Chapter 4 to configure settings.



### 9.13.2 Panel PCB ASSY / NFC PCB ASSY / LCD

- (1) Disconnect the Key flat cable from the Panel PCB ASSY, and release it from the securing fixtures.
- (2) Release the Hook A to remove the LCD pressure plate from the Panel unit.
- (3) Remove the four Taptite cup B M3x10 screws to remove the Shield plate cover from the Panel unit.
- (4) Release the Lock to disconnect the LCD flat cable from the Panel PCB ASSY. Disconnect the NFC flat cable from the Panel PCB ASSY, and remove the Panel PCB ASSY from the Panel unit.
- (5) Remove the Shield plate base from the Panel unit.
- (6) Release the Hook B to remove the NFC PCB ASSY from the Panel unit.
- (7) Remove the LCD from the Panel unit.

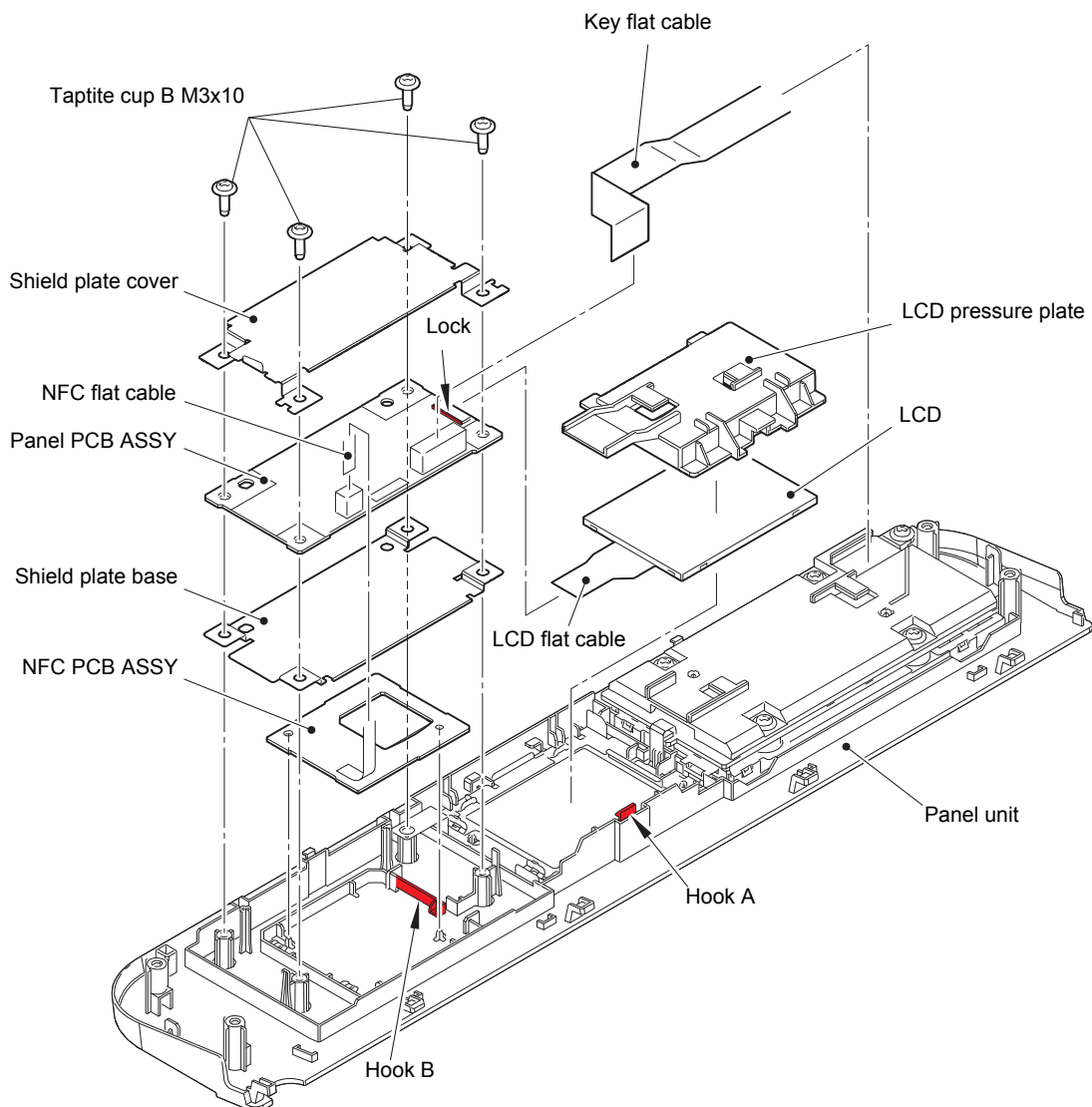


Fig. 3-48

Harness routing: Refer to "5. Panel unit".

### 9.13.3 Touch panel ASSY

- (1) Remove the four Taptite cup B M3x10 screws to remove the Panel key PCB presser from the Panel unit.
- (2) Disconnect the Touch panel flat cable from the Key PCB ASSY. Remove the Key PCB ASSY from the Panel unit.
- (3) Release each Lock to remove the Anti static plate from the Panel unit.
- (4) Release the Touch panel plate from the Boss, and slide it in the direction of the arrow to remove it from the Panel unit. Remove the LCD frame sheet from the Panel unit.
- (5) Remove the Touch panel ASSY from the Panel unit.

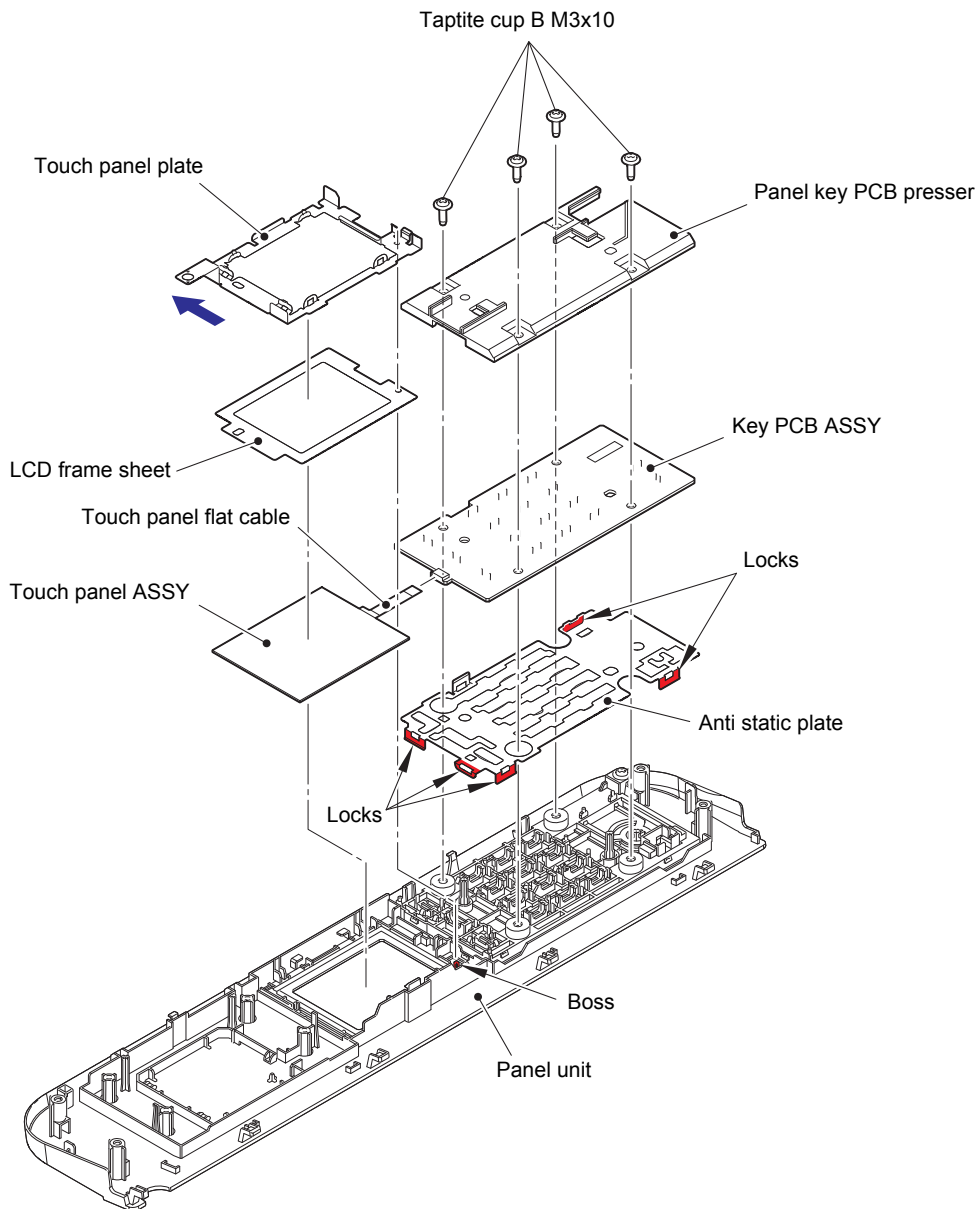


Fig. 3-49

#### Assembling Note:

- If you replaced the Touch panel ASSY, refer to “4. IF YOU REPLACE THE PANEL UNIT OR PANEL CONTROL PCB” in Chapter 4 to configure settings.

## 9.14 Panel unit (For Non-touch panel models)

### 9.14.1 Panel unit

- (1) Remove the four Taptite cup B M3x10 screws.
- (2) Release each Hook to remove the Panel unit. Disconnect the Panel flat cable from the Panel PCB ASSY.

**Note:**

- When removing the Panel unit, DO NOT pull the Panel unit strongly because it is connected to the Panel flat cable.

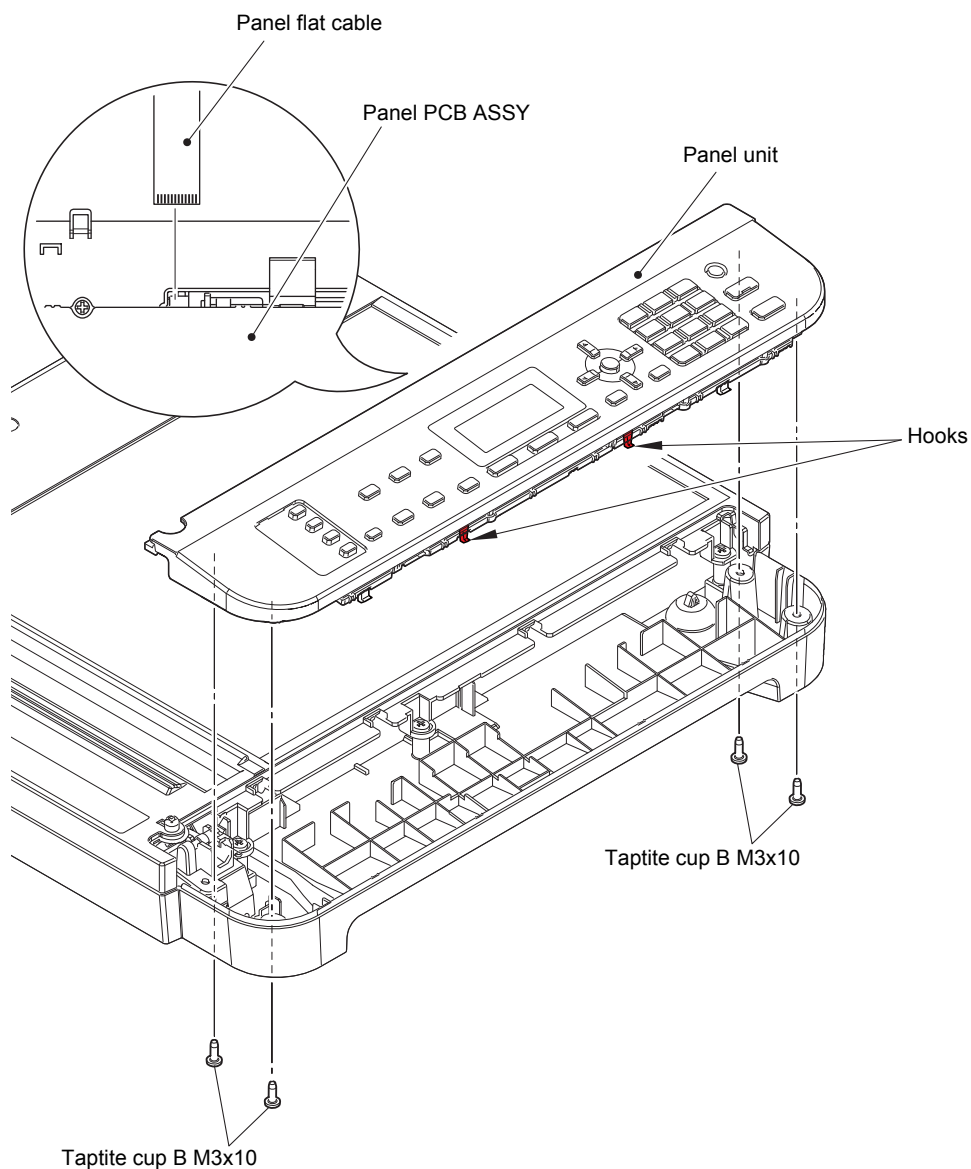


Fig. 3-50

Harness routing: Refer to "3. Document scanner unit".

### 9.14.2 Panel PCB ASSY

- (1) Release each Hook to remove the Panel PCB ASSY from the Panel unit.
- (2) Reverse the Panel PCB ASSY. Release the Lock to disconnect the LCD flat cable from the Panel PCB ASSY.

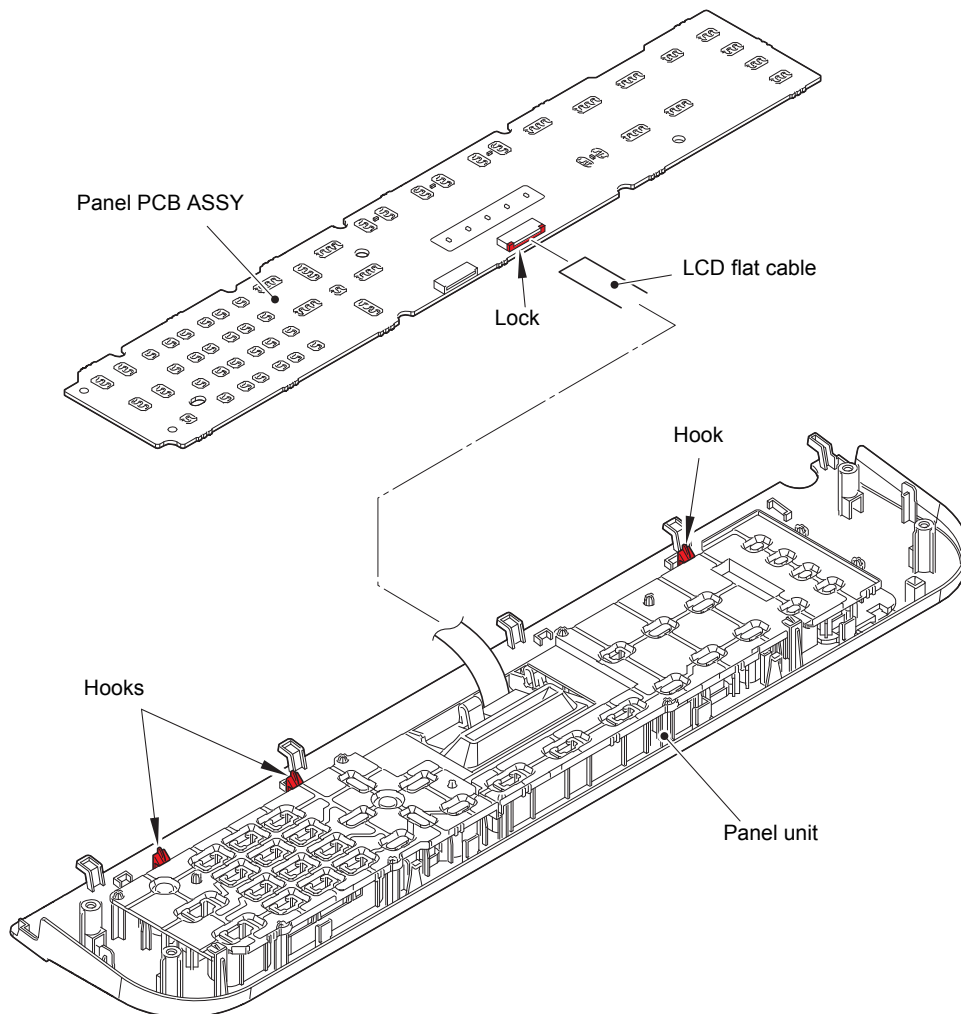


Fig. 3-51

### 9.14.3 LCD

- (1) Remove the Rubber key L and the Rubber key R from the Panel unit.
- (2) Release each Hook A to remove the Backlight guide from the Panel unit.
- (3) Remove the Diffusion film.
- (4) Release the Hook B to remove the LCD from the Backlight guide.
- (5) Remove the LCD sheet from the Panel unit.
- (6) Remove the Address label from the Panel unit.

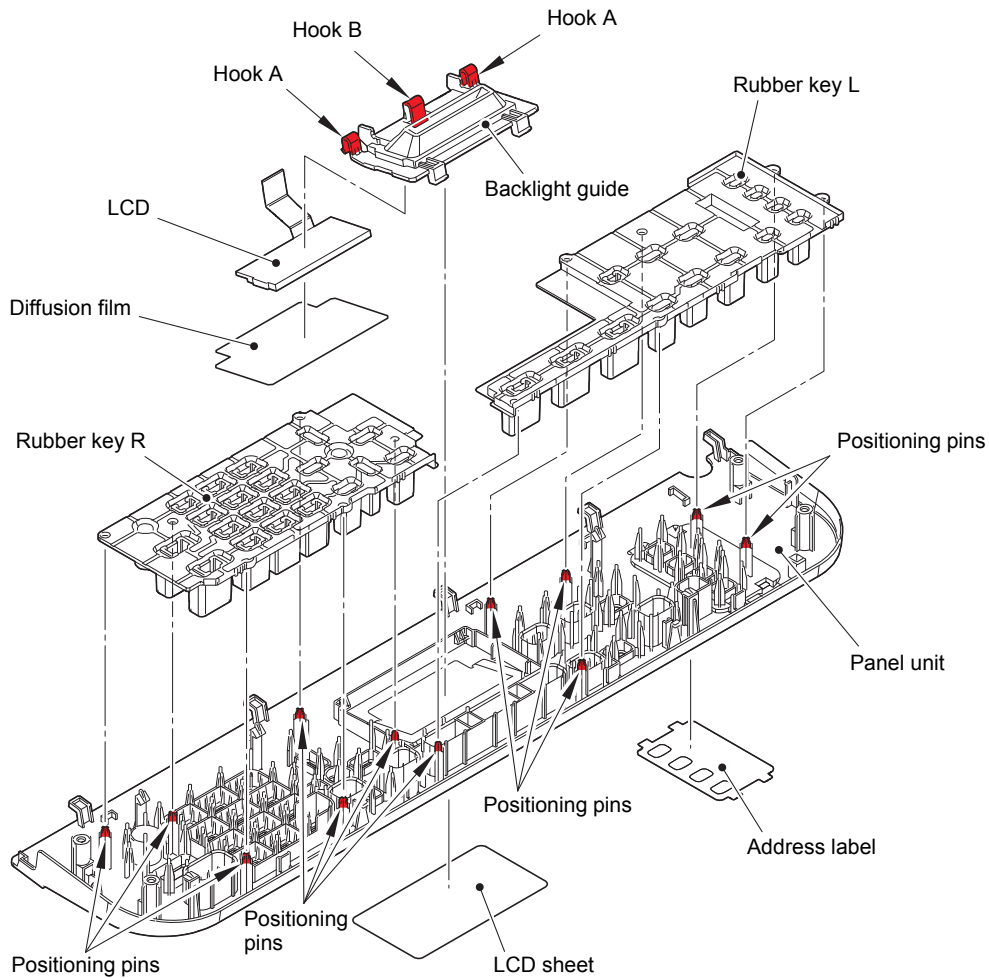


Fig. 3-52

#### Assembling Note:

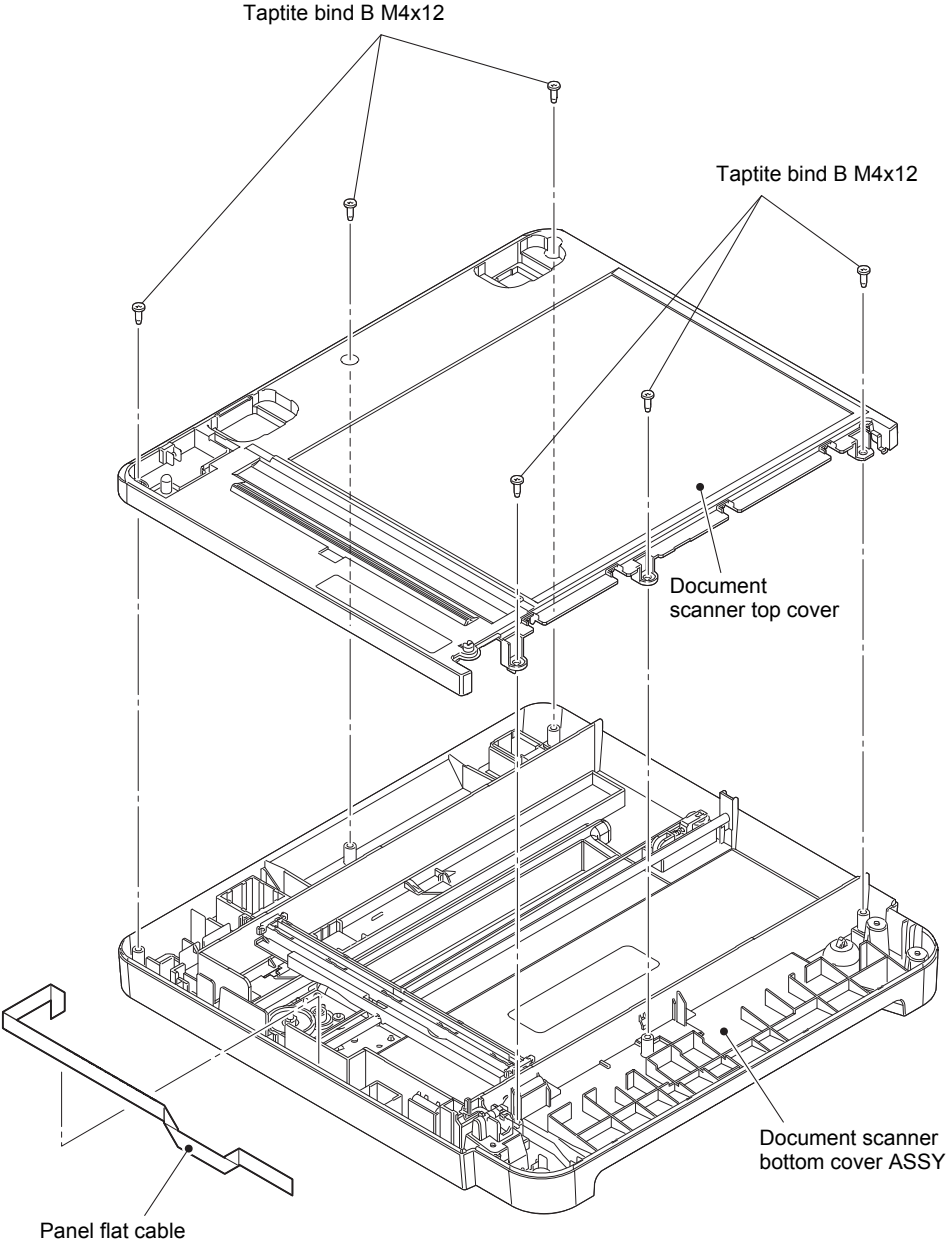
- When assembling the LCD, attach the Rubber key R and the Rubber key L in this order.
- Make sure that the Positioning pins are inserted to the holes of the Rubber key L/R.
- DO NOT bend the Hooks when removing them. If the Hooks are deformed, the LCD may not be attached to the Backlight guide or the Backlight guide may not be attached to the Panel unit.

# 9.15 Panel flat cable / First side CIS unit / First side CIS flat cable

**Note:**

- Disassemble in a dust-free location.

- (1) Remove the six Taptite bind B M4x12 screws to remove the Document scanner top cover from the Document scanner bottom cover ASSY.
- (2) Release the Panel flat cable from the securing fixtures, and remove it from the Document scanner bottom cover ASSY.

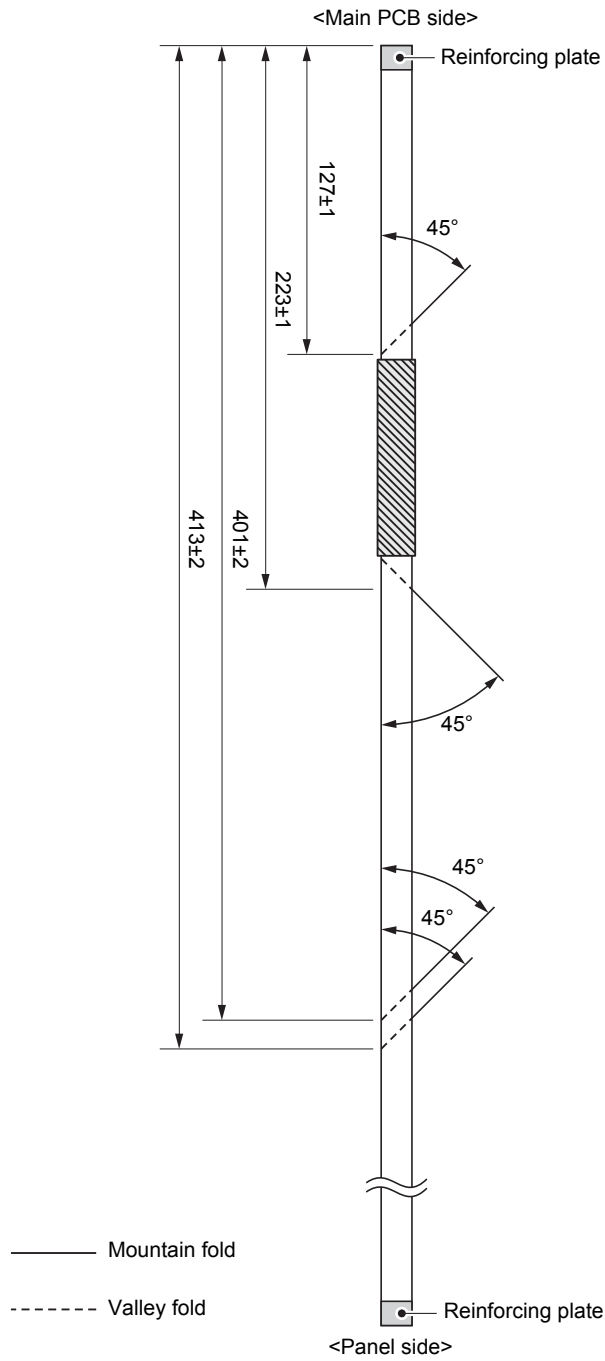


**Fig. 3-53**

Harness routing: Refer to "6. First side CIS unit, Panel".

**Assembling Note:**

- Fold the Panel flat cable at the positions described below.

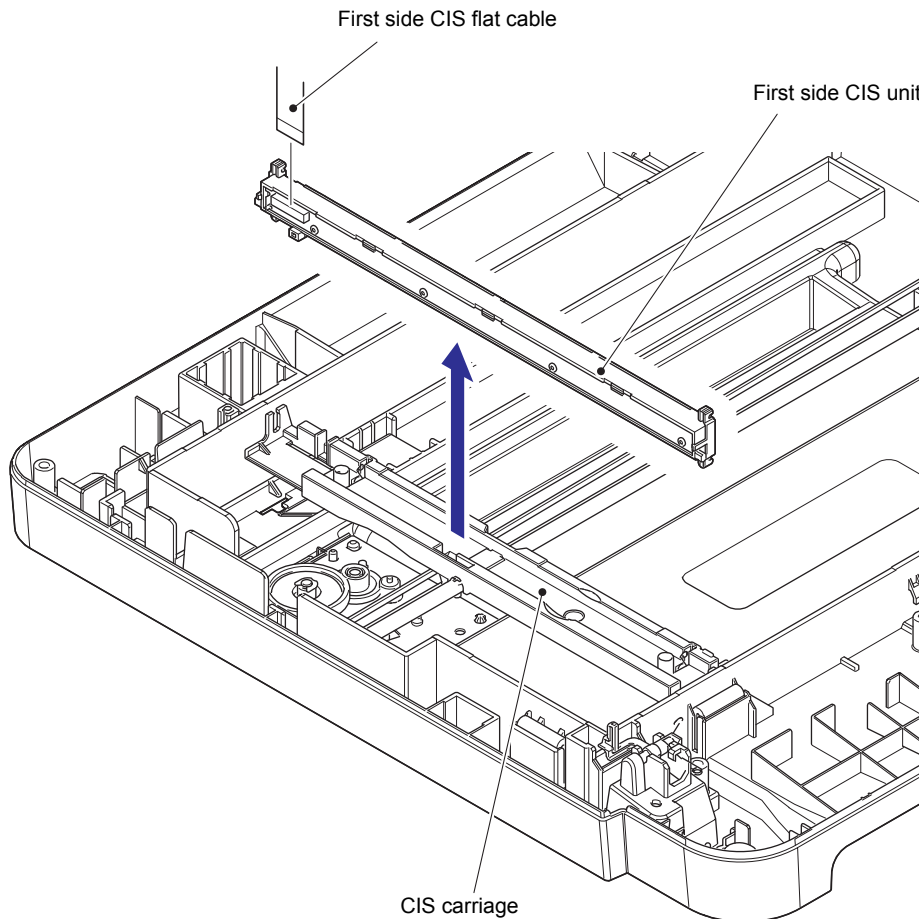


**Fig. 3-54**

**Assembling Note:**

- If you replaced the First side CIS unit, refer to “5. IF YOU REPLACE THE ADF UNIT, FIRST SIDE CIS UNIT, SECOND SIDE CIS UNIT OR DOCUMENT SCANNER UNIT” in Chapter 4 to configure settings.

- (3) Slide the CIS carriage slowly to the location shown in the figure below.
- (4) Open the First side CIS unit at 90 degrees to the CIS carriage, and remove it from the CIS carriage. Disconnect the First side CIS flat cable from the First side CIS unit.



**Fig. 3-55**

**Assembling Note:**

- Acquire the white level data, and set the CIS scanning area.  
(Refer to “1.3.16 Acquire white level data and set CIS scan area (Function code 55)” in Chapter 5.)

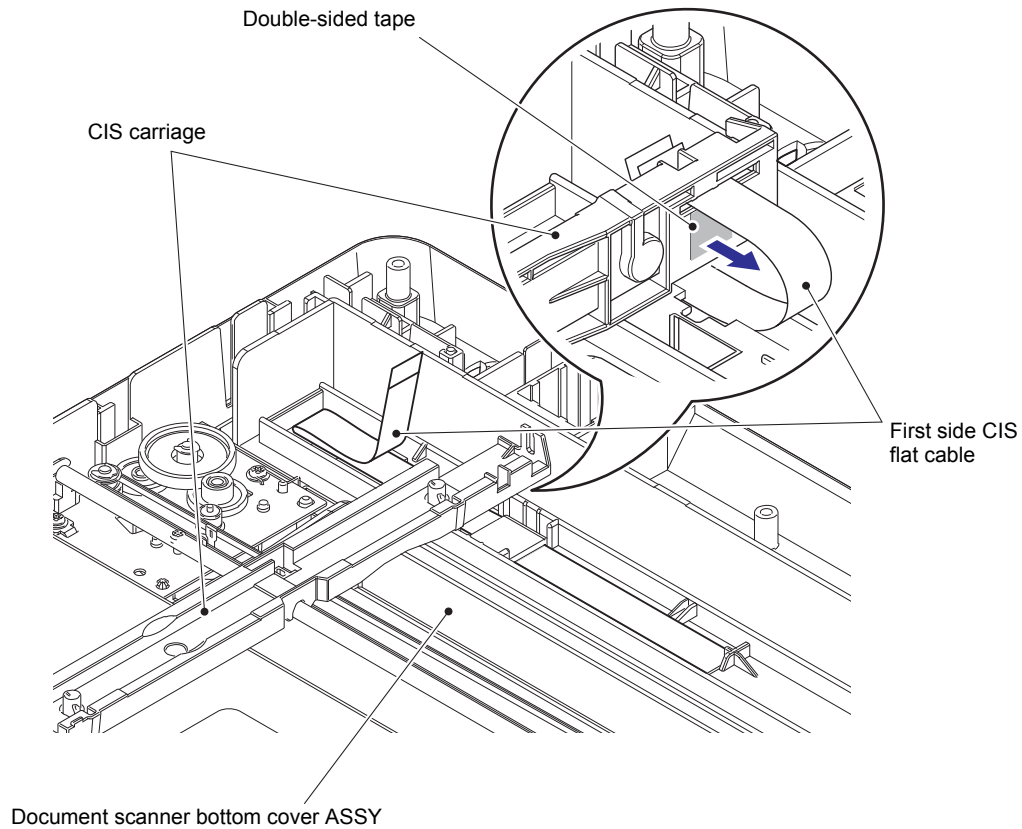


(5) Remove the First side CIS flat cable from the back of the CIS carriage.

**Note:**

- Be sure to replace the Double-sided tape with a new one, after taking off the Double-sided tape from the CIS carriage.

(6) Remove the First side CIS flat cable from the Document scanner bottom cover ASSY.

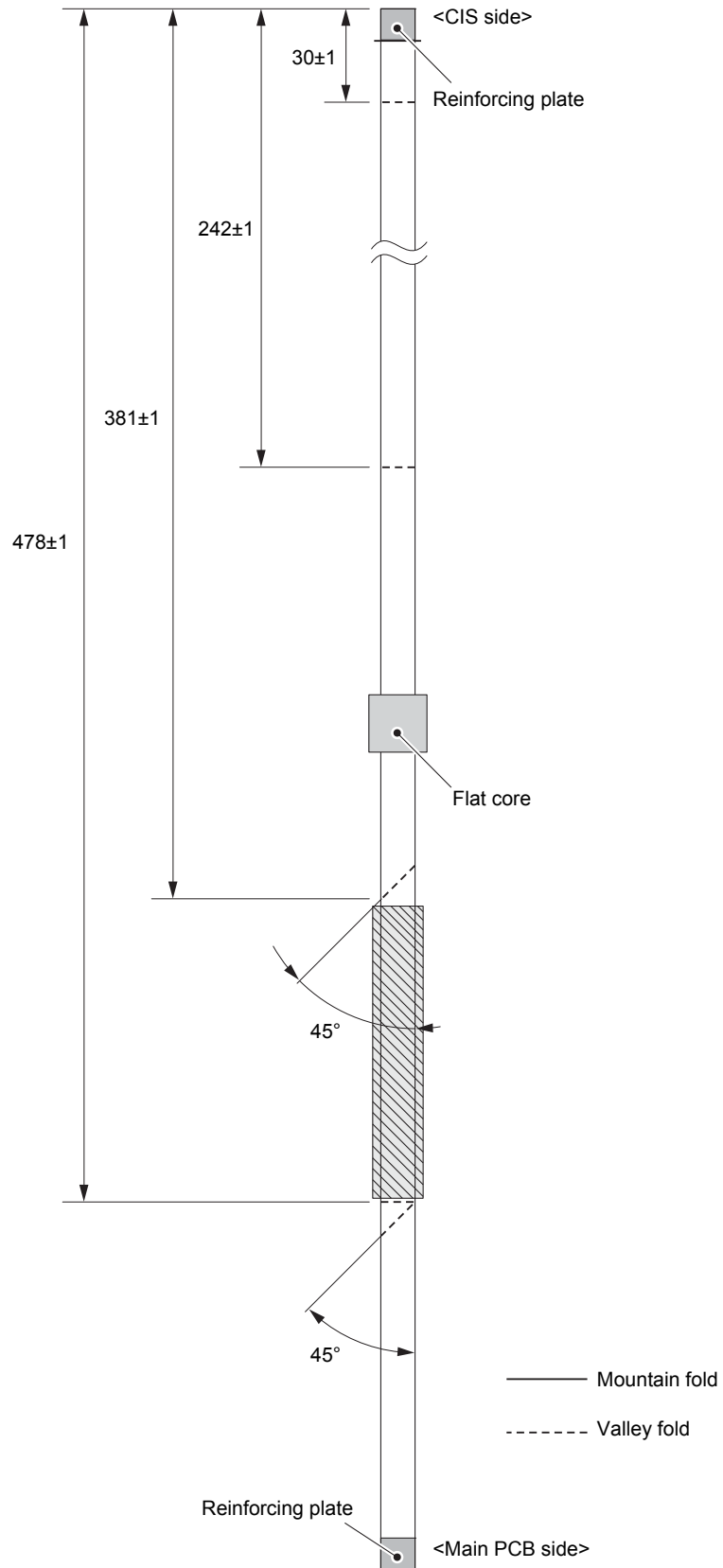


**Fig. 3-56**

Harness routing: Refer to "6. First side CIS unit, Panel".

**<Attachment Procedure>**

1) Fold the First side CIS flat cable as shown the illustration below.



**Fig. 3-57**

- 2) Attach the two pieces of Double-sided tape to the Document scanner bottom cover ASSY at the positions shown in the figure below. (If the old Double-sided tape remains attached, replace it with a new one.)

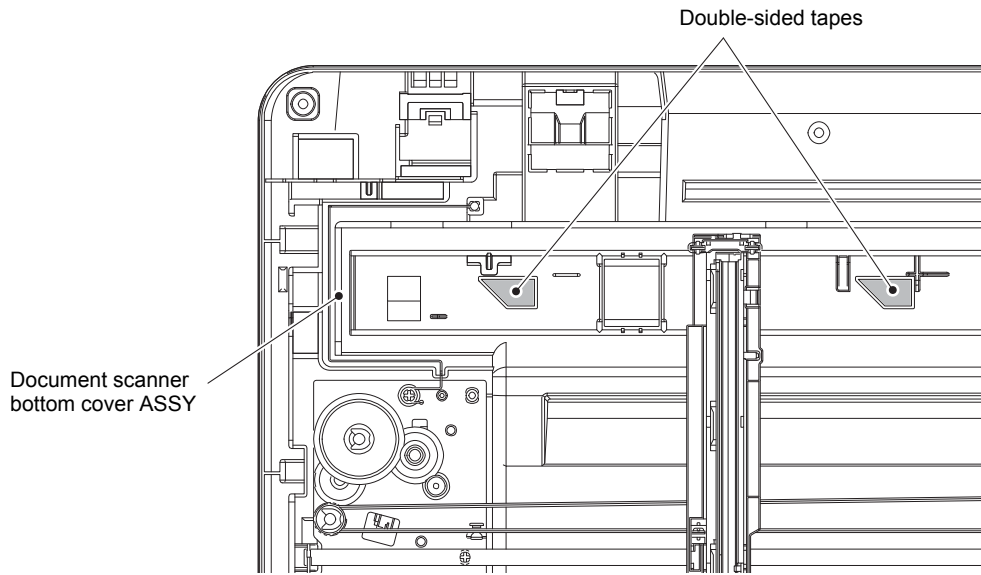


Fig. 3-58

- 3) Attach the 9 mm x 9 mm Double-sided tape to the CIS carriage at the position shown in the figure below. (If the old Double-sided tape remains attached, replace it with a new one.)
- 4) Connect the First side CIS flat cable to the First side CIS unit.
- 5) Attach the First side CIS unit to the CIS carriage.
- 6) Peel the release liner of the Double-sided tape attached to the CIS carriage, and secure the First side CIS flat cable with the tape as shown in the figure below.

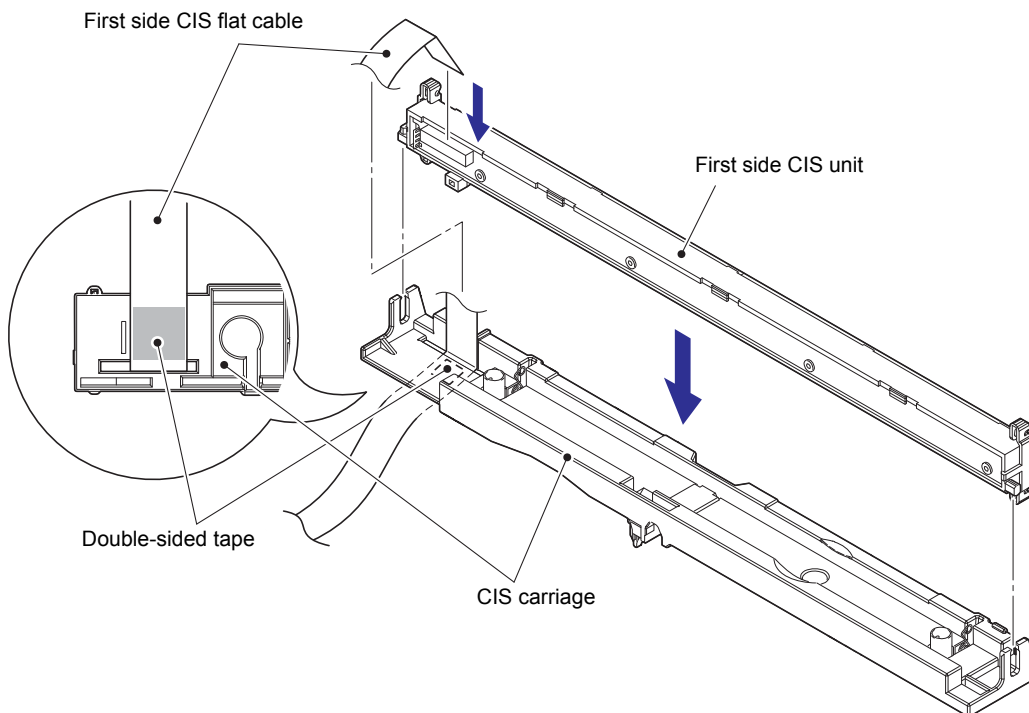
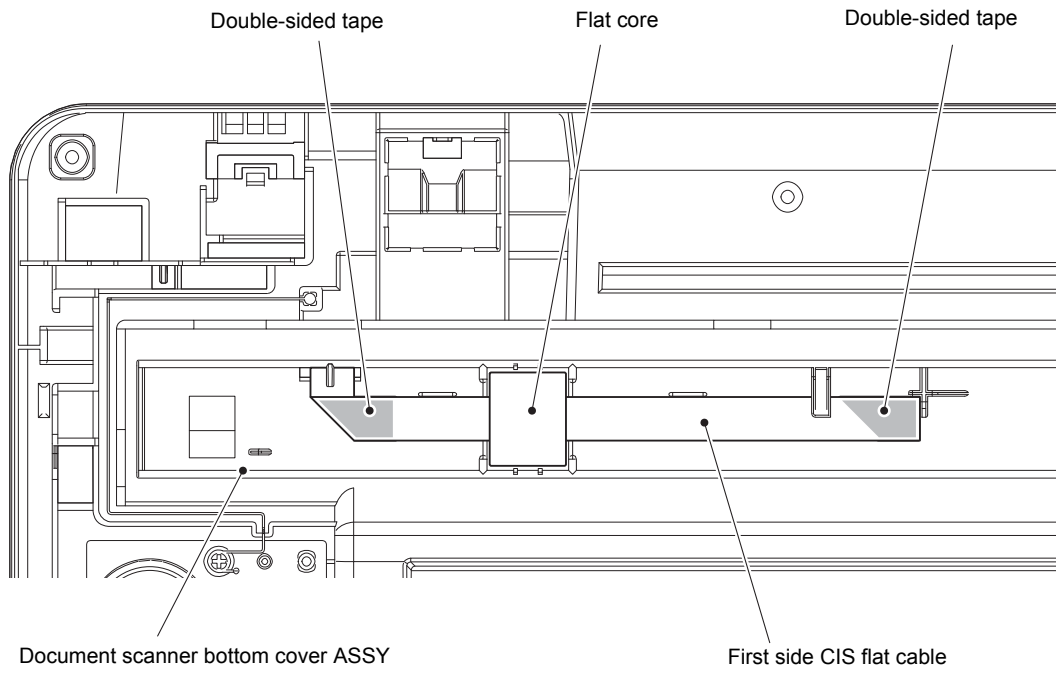


Fig. 3-59

- 7) Pass the First side CIS flat cable through the Flat core.
- 8) Peel the release liner of the two pieces of Double-sided tape attached to the Document scanner bottom cover ASSY, and secure the First side CIS flat cable with the tapes as shown in the figure below.



**Fig. 3-60**

Harness routing: Refer to "6. First side CIS unit, Panel".

## 9.16 Modem flat cable / Modem PCB ASSY

- (1) Remove the two Screw cup M3x8 (black) screws, and release the Modem ground harness LVPS from the securing fixtures.

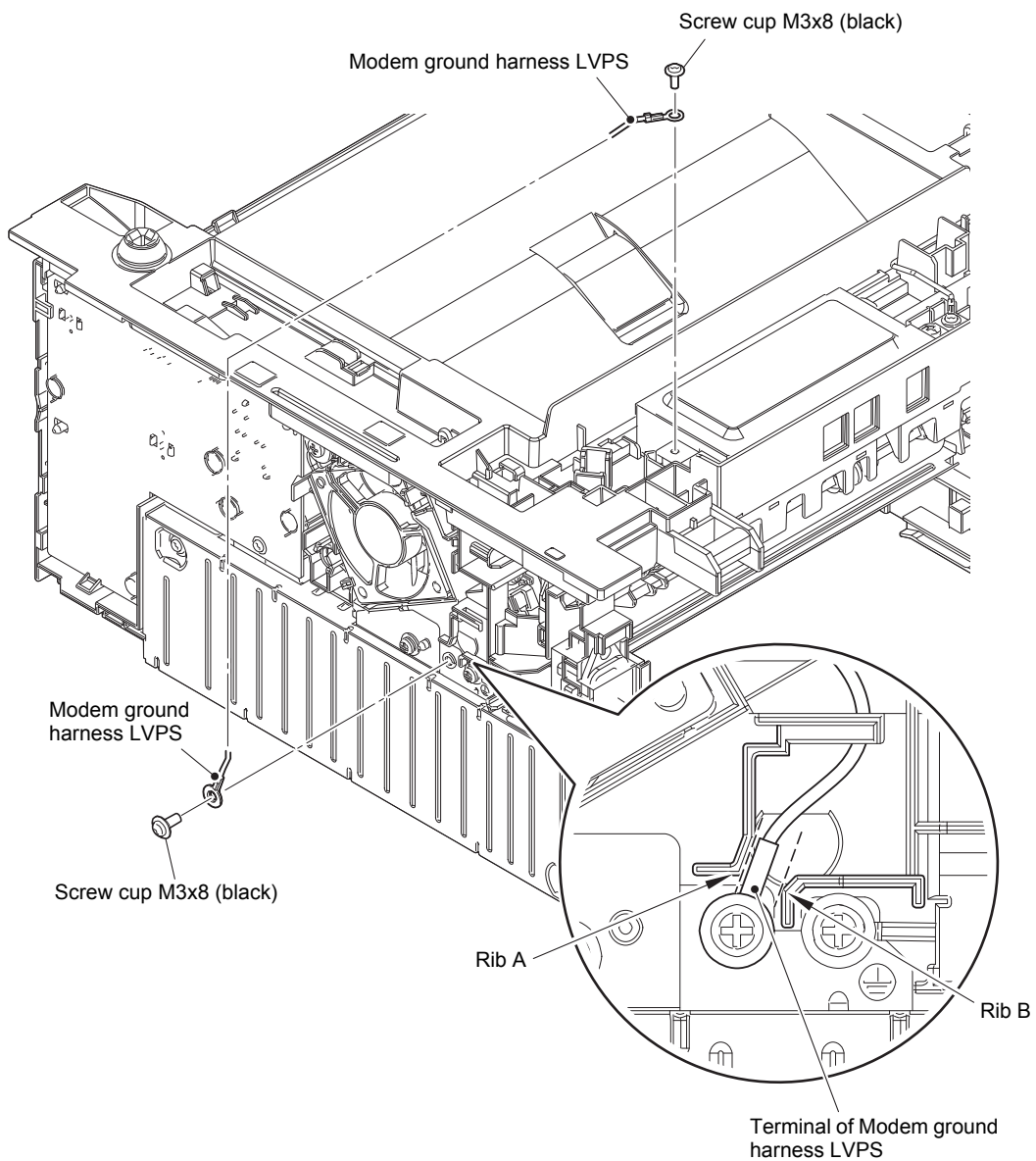


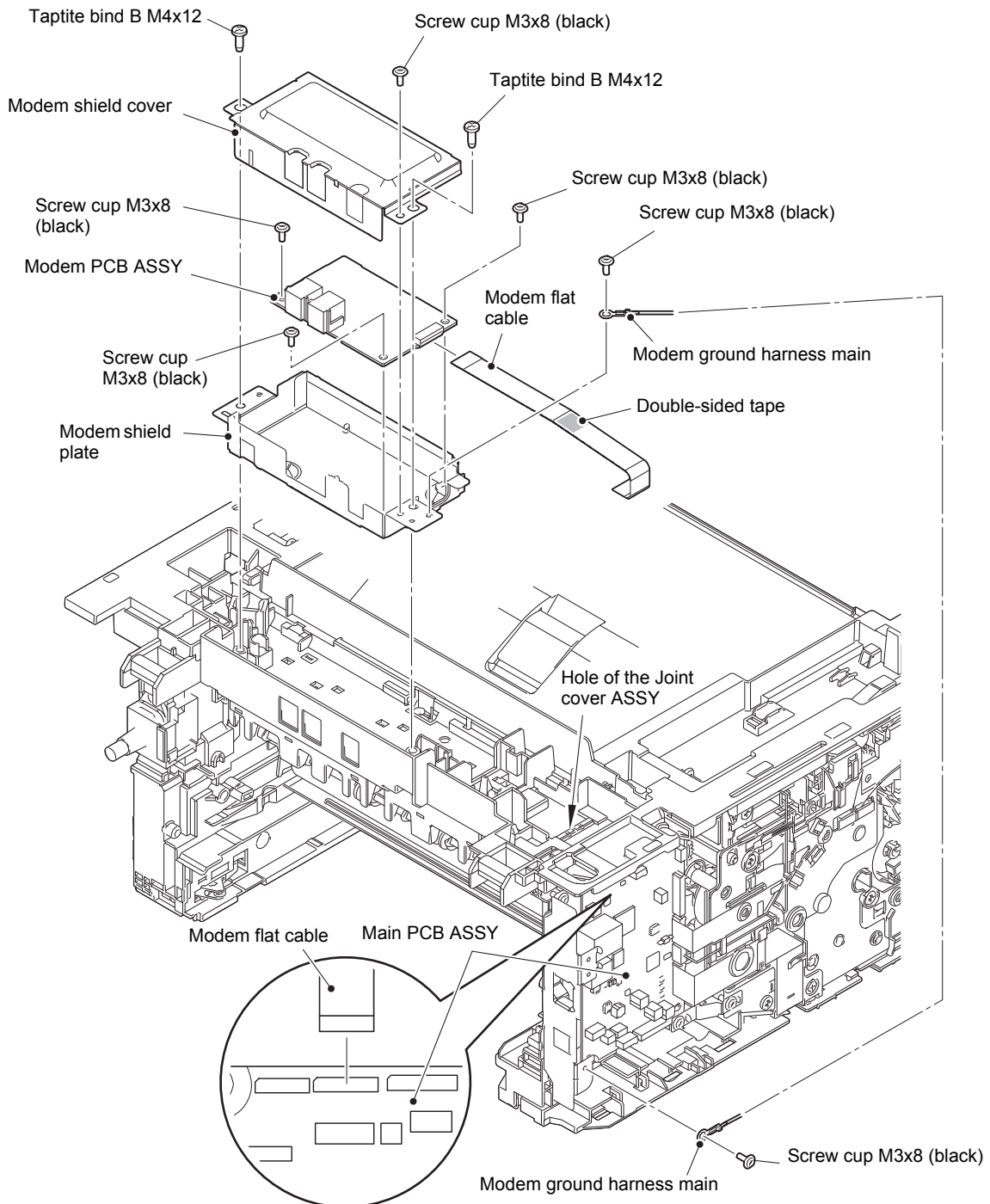
Fig. 3-61

Harness routing: Refer to "7. Modem PCB ASSY (LVPS side)".

### Assembling Note:

- Make sure that the Terminal of Modem ground harness LVPS is located between the Rib A and the Rib B as shown in the figure above.

- (2) Remove the two Screw cup M3x8 (black) screws, and release the Modem ground harness main from the securing fixtures.
- (3) Disconnect the Modem flat cable from the Main PCB ASSY and the Modem PCB ASSY, and remove it from the Double-sided tape to pull it out from the hole of the Joint cover ASSY.
- (4) Remove the two Taptite bind B M4x12 screws to remove the Modem shield plate.
- (5) Remove the Screw cup M3x8 (black) screw to remove the Modem shield cover from the Modem shield plate.
- (6) Remove the three Screw cup M3x8 (black) screws to remove the Modem PCB ASSY from the Modem shield plate.



**Fig. 3-62**

Harness routing: Refer to "7. Modem PCB ASSY (LVPS side)".

# 9.17 Joint cover ASSY

- (1) Remove the four Taptite bind B M4x12 screws.
- (2) Release the Hooks in order of the Hook A to D, and remove the Joint cover ASSY in the direction of the arrow.

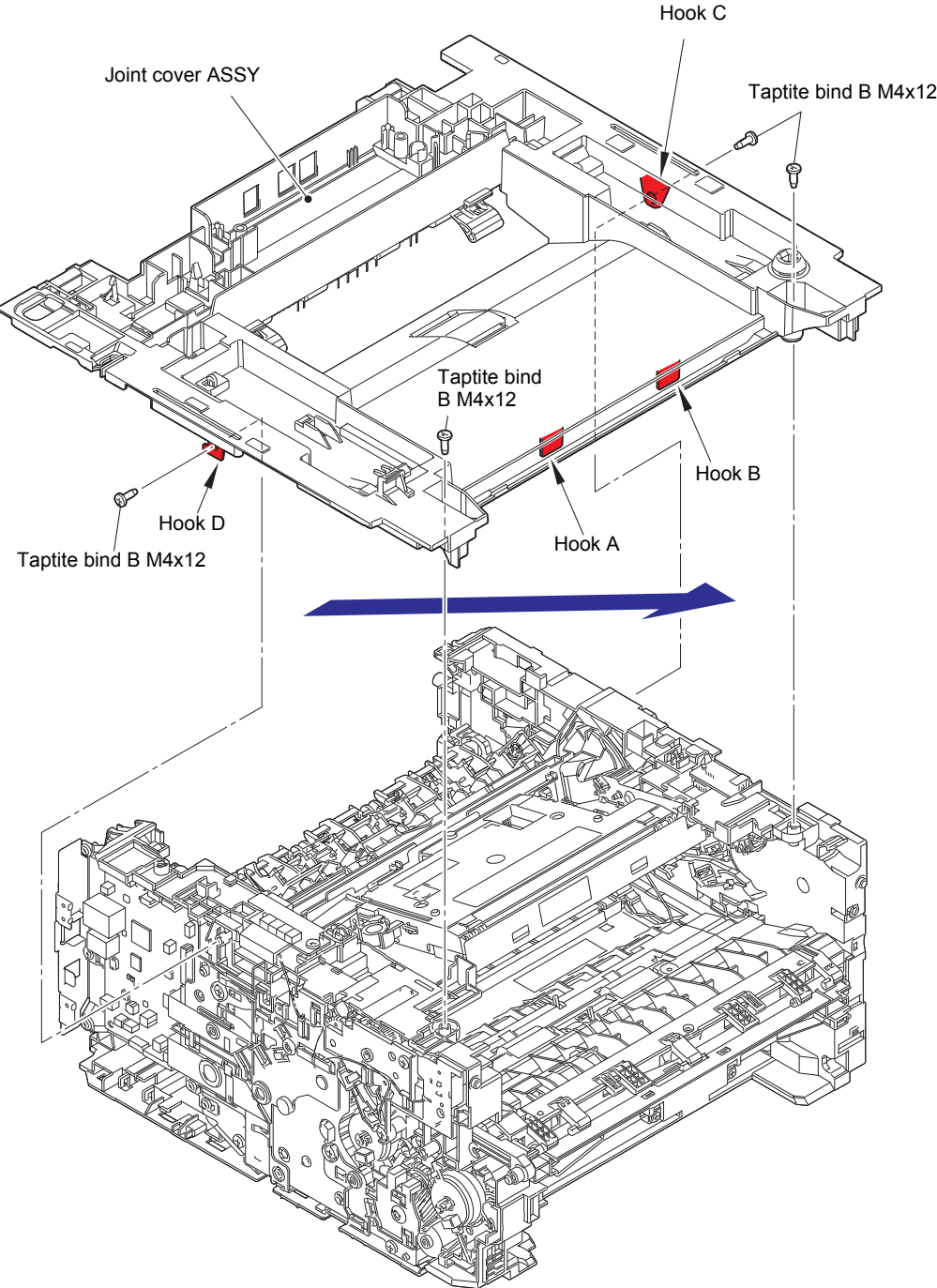


Fig. 3-63

## 9.18 Fuser unit

- (1) Release the Fuser unit heater harness from the securing fixtures, and disconnect it from the LVPS-heater harness.

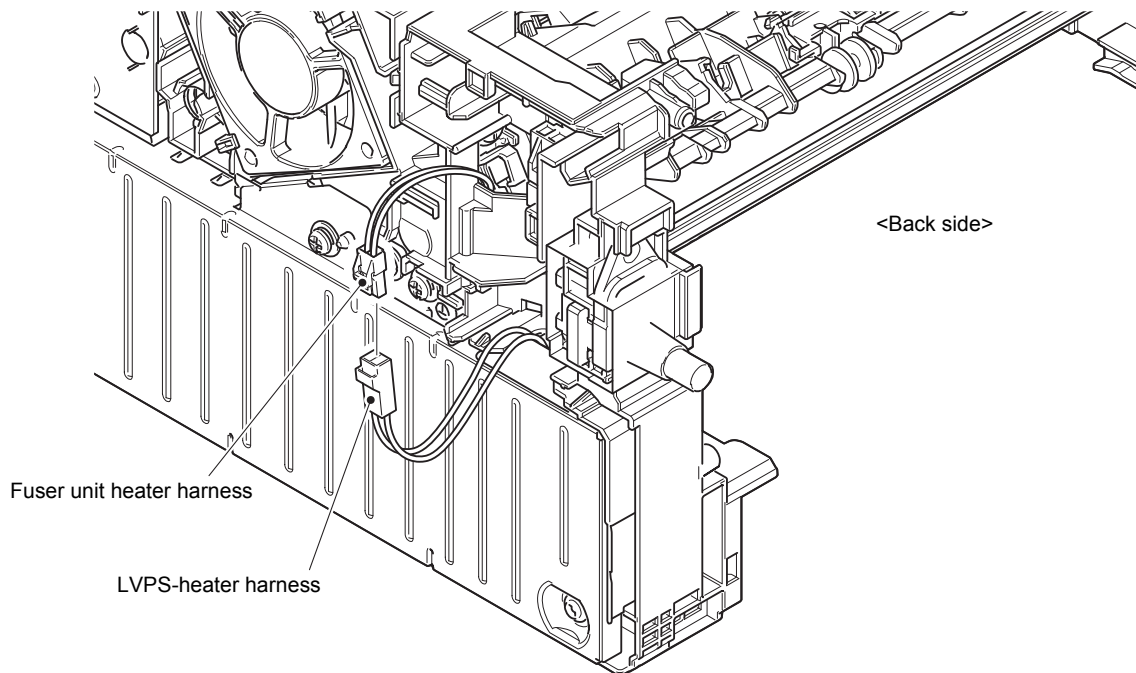


Fig. 3-64

Harness routing: Refer to "8. Rear side of the machine".

- (2) Disconnect the Center thermistor harness ASSY and the Side thermistor harness ASSY from the Eject sensor PCB ASSY.
- (3) Release the Center thermistor harness ASSY and the Side thermistor harness ASSY from the securing fixtures.

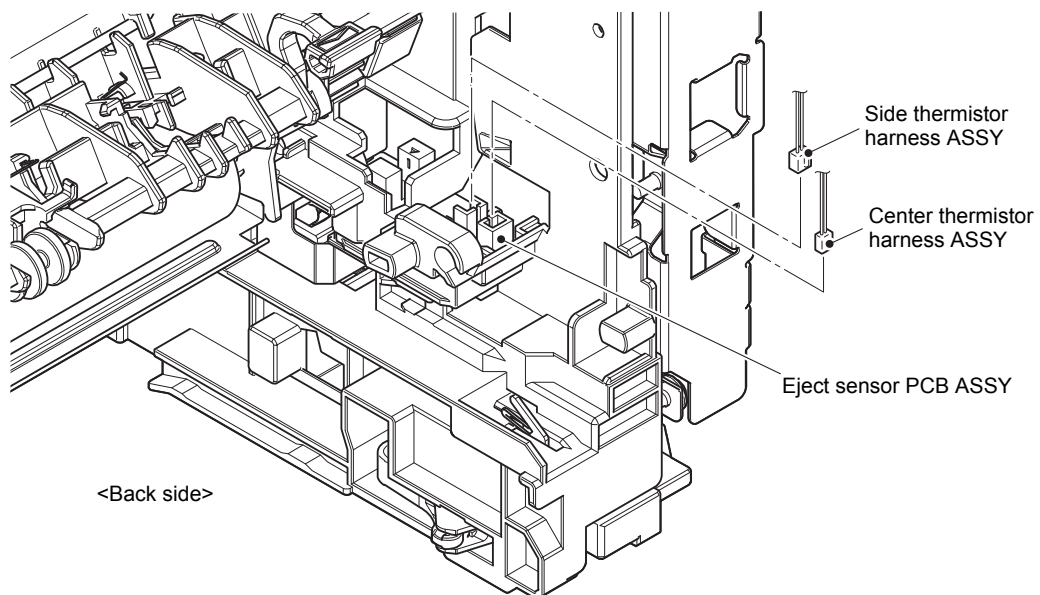


Fig. 3-65

Harness routing: Refer to "8. Rear side of the machine".



(4) Remove the two Taptite pan B M4x14 screws, and remove the Fuser unit.

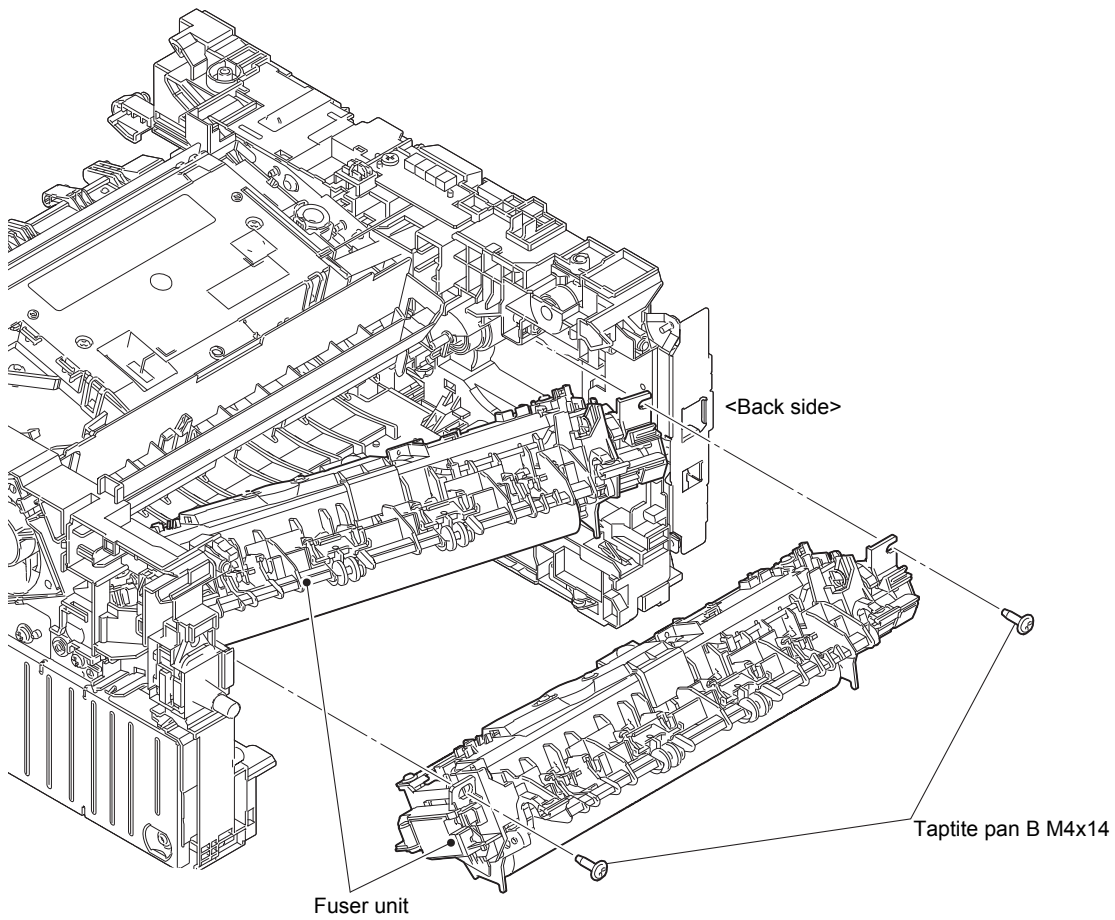


Fig. 3-66

**Note:**

- DO NOT apply a physical impact or vibration to the Fuser unit.
- DO NOT touch the roller and the electrodes to prevent breakage of the Fuser unit.

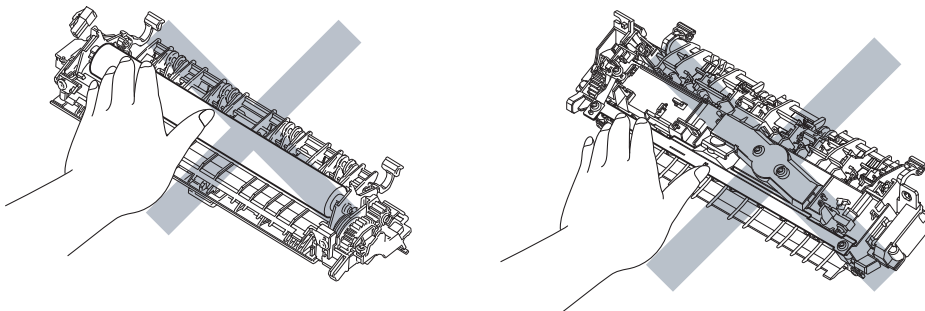


Fig. 3-67

## 9.19 Low-voltage power supply PCB ASSY



### WARNING

When removing the Low-voltage power supply, DO NOT touch it within **3 minutes** after disconnecting the AC cord as it may cause an electric shock due to the electric charge accumulated in the capacitor.

- (1) Remove the two Screw cup M3x8 (black) screws, the Screw pan M4x8 screw, the Washer spring 2-4, and the Washer 5, and remove the LVPS shield plate cover and the LVPS insulation sheet.

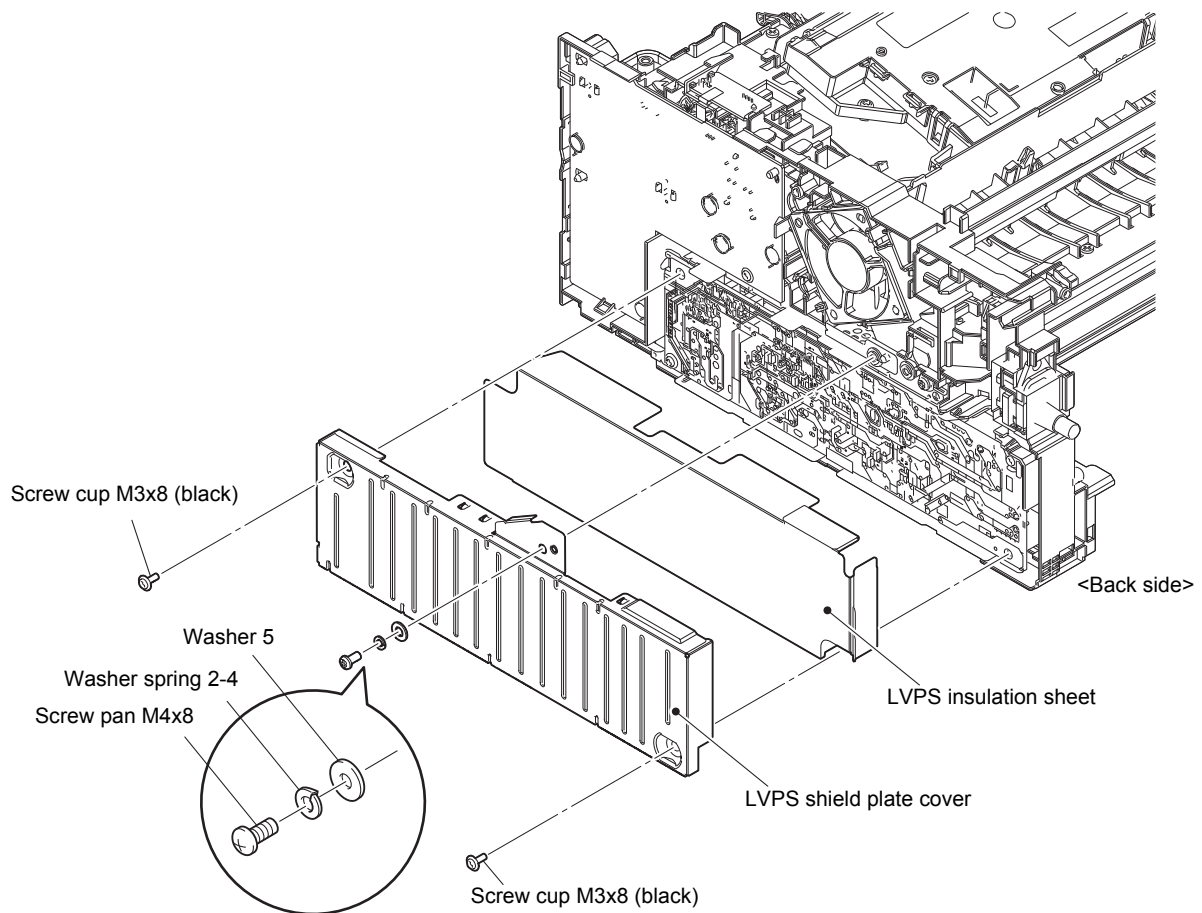
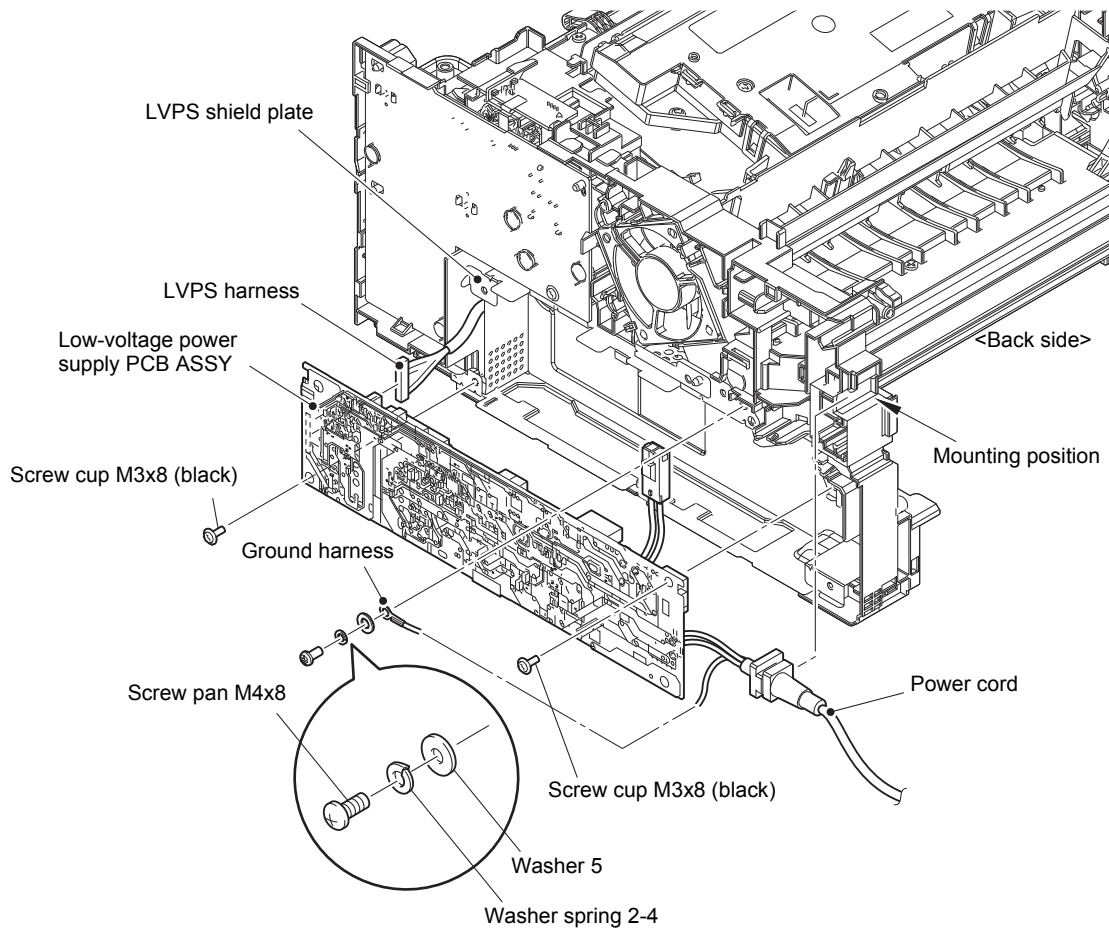


Fig. 3-68

#### Assembling Note:

- Make sure to attach the LVPS insulation sheet. Failure to attach the insulation sheet can result in fire or electrical shock.

- (2) Remove the Screw pan M4x8 screw, the Washer spring 2-4, and the Washer 5, and remove the Ground harness from the LVPS shield plate.
- (3) Release the Ground harness from the securing fixtures.
- (4) Remove the Power cord from the Mounting position and release it from the securing fixtures.
- (5) Remove the two Screw cup M3x8 (black) screws to remove the Low-voltage power supply PCB ASSY. Disconnect the LVPS harness from the back of the Low-voltage power supply PCB ASSY.



**Fig. 3-69**

Harness routing: Refer to "8. Rear side of the machine".

**Assembling Note:**

- After the replacement, refer to "2. IF YOU REPLACE THE LOW-VOLTAGE POWER SUPPLY PCB ASSY" in Chapter 4 to reset irregular power supply detection counter of the Low-voltage power supply PCB ASSY.

# 9.20 New toner sensor PCB ASSY

- (1) Disconnect the New toner sensor flat cable from the High-voltage power supply PCB ASSY, and release the Hook to remove the New toner sensor PCB ASSY. Disconnect the Registration front/rear sensor harness from the New toner sensor PCB ASSY.

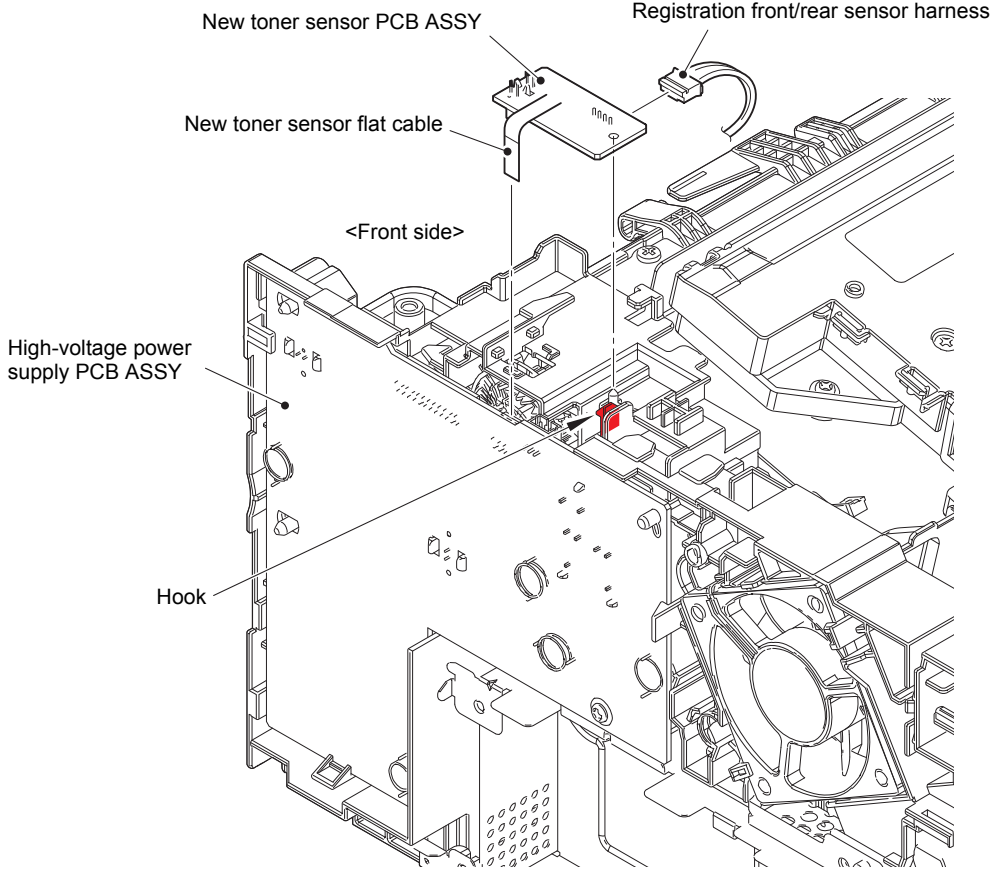


Fig. 3-70

Harness routing: Refer to "8. Rear side of the machine".

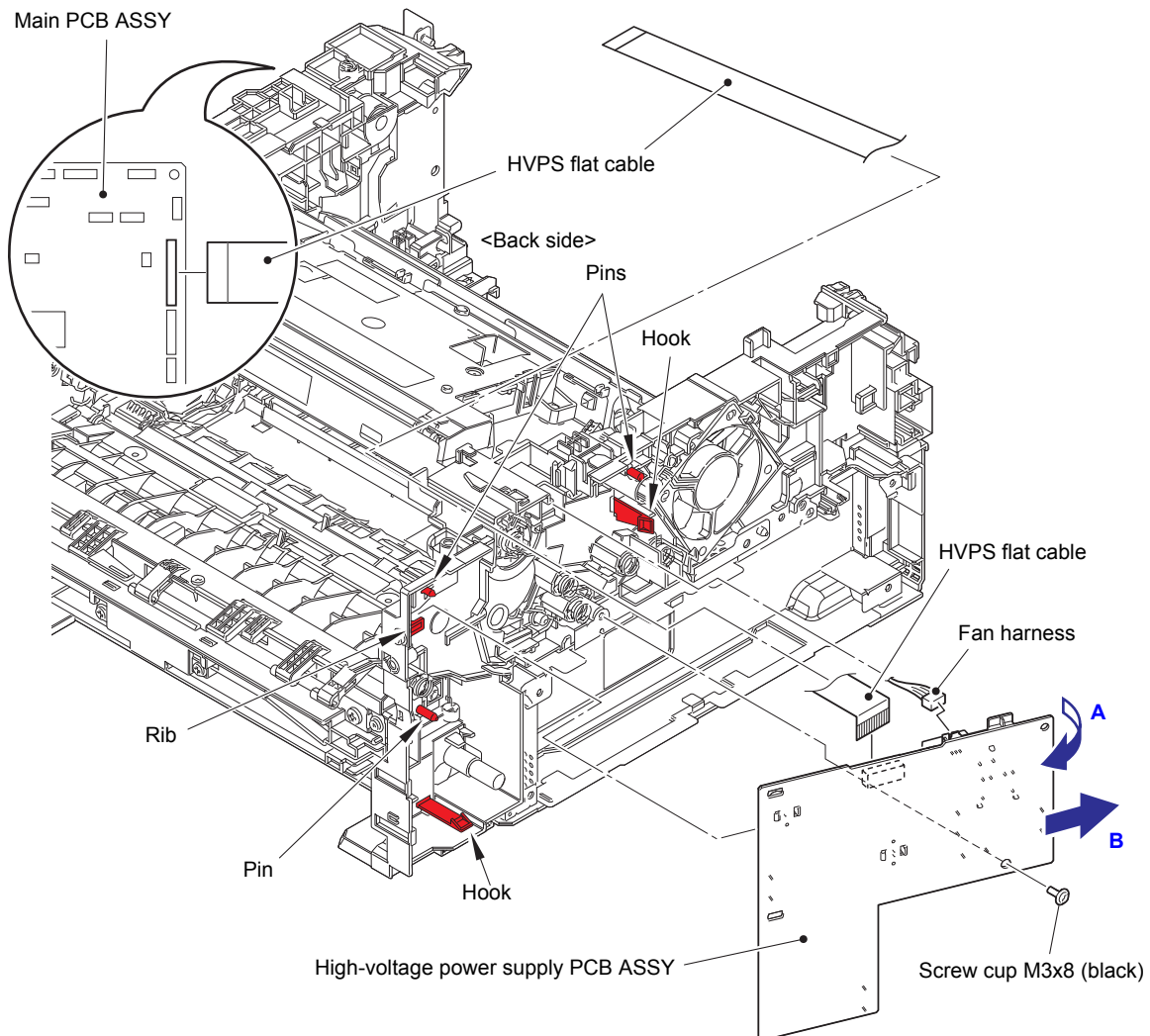
## 9.21 HVPS flat cable / High-voltage power supply PCB ASSY

- (1) Disconnect the HVPS flat cable from the High-voltage power supply PCB ASSY. Disconnect the HVPS flat cable from the Main PCB ASSY, and release it from the securing fixtures.

**Note:**

- After disconnecting flat cables, check that each cable is not damaged at its end or short-circuited.
- When connecting flat cables, do not insert them at an angle. After insertion, check that the cables are not at an angle.

- (2) Disconnect the Fan harness from the High-voltage power supply PCB ASSY.
- (3) Remove the Screw cup M3x8 (black) screw. Release each Hook and pull out the right side of the High-voltage power supply PCB ASSY in the direction of the arrow A to remove it from the Pins. And then pull out the High-voltage power supply PCB ASSY in the direction of the arrow B to remove it from the Rib.



**Fig. 3-71**

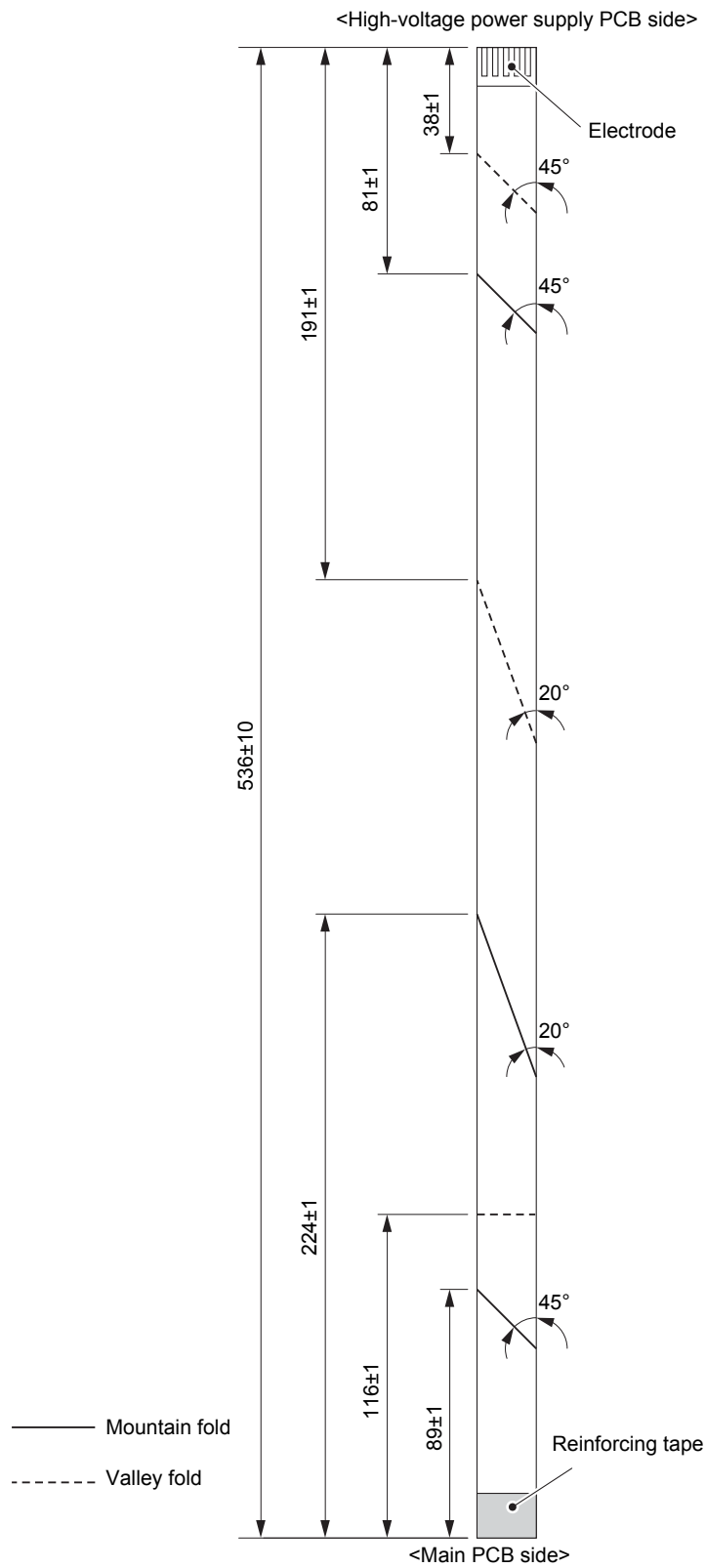
Harness routing: Refer to “8. Rear side of the machine”, “9. Top side of the machine”.

**Assembling Note:**

- After attaching the High-voltage power supply PCB ASSY, push the Electrode springs from inside of the machine to check that nothing is caught. (Refer to Fig. 2-12.)

**Assembling Note:**

- Fold the HVPS flat cable at the positions described below.



**Fig. 3-72**

## 9.22 Fan

- (1) Release the Fan harness from the securing fixtures.
- (2) Release each Hook to remove the Fan, and pull out the Fan harness from the Hole.

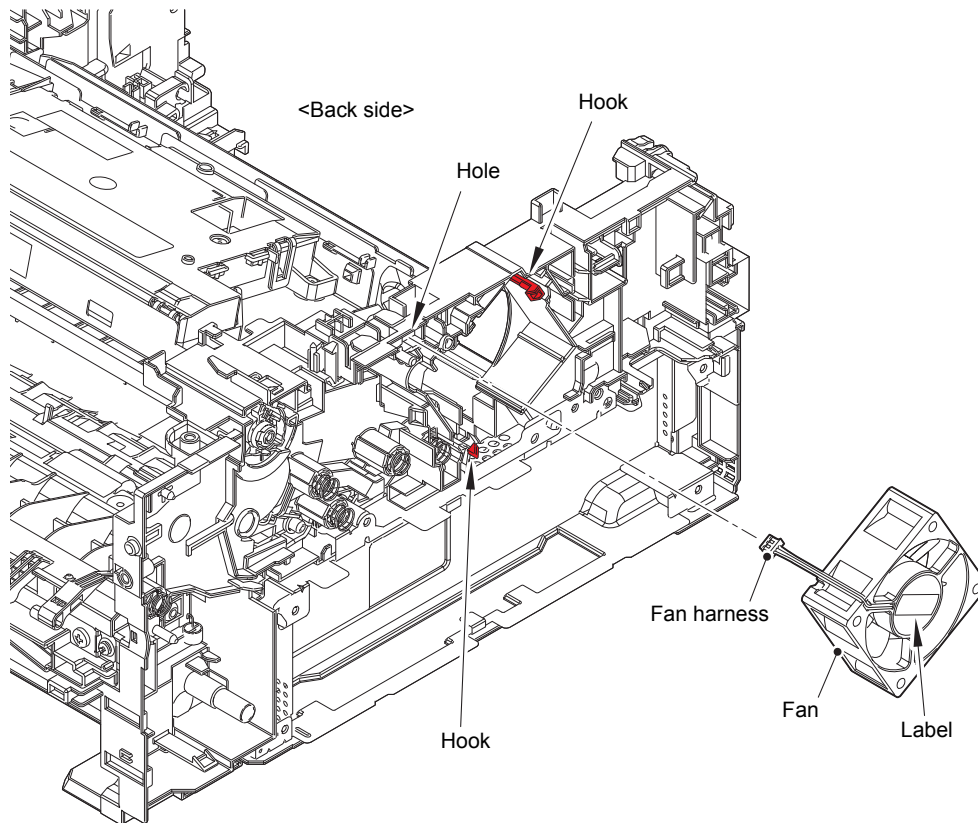


Fig. 3-73

Harness routing: Refer to "8. Rear side of the machine".

### Assembling Note:

- When assembling the Fan, insert the Fan harness into the hole to make sure that the Fan harness is not caught.
- Attach the Fan so that the surface with the Label faces out.



## 9.23 Toner box relay PCB ASSY (For models with toner box)/ MP relay PCB ASSY (For MP models) / Toner box new PCB ASSY (For models with toner box)

### ■ Toner box models

- (1) Disconnect the Toner box relay flat cable from the Main PCB ASSY.
- (2) Release the Toner sensor harness, the Toner box new harness, and the Toner box solenoid harness from the securing fixtures.
- (3) Remove the Taptite bind B M4x12 screw. Remove the Toner box relay PCB ASSY, and disconnect each harness from the Toner box relay PCB ASSY.
- (4) Remove the Taptite bind B M3x8 screw to remove the Shading film and the Toner box new PCB ASSY.

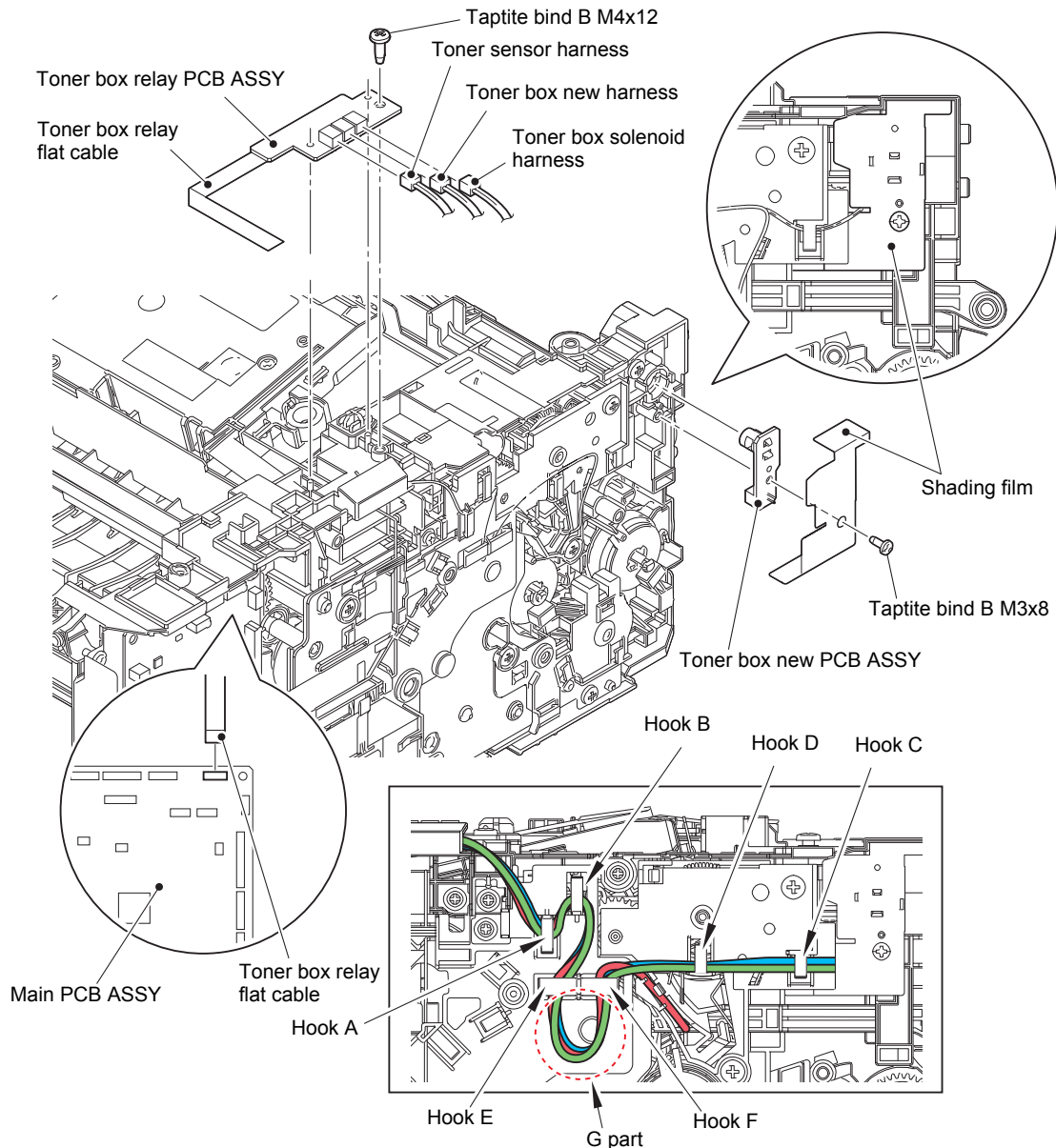


Fig. 3-74

Harness routing: Refer to "9. Top side of the machine", "10. Frame L unit (Manual feed models)".

#### Assembling Note:

- Secure each harness in the Hooks in order of the Hook A to D, and then secure them in the Hooks from the Hook E to F. Be sure to give them enough slack in the G part for adjustment.



## ■ MP models

- (1) Disconnect the MP relay flat cable from the Main PCB ASSY.
- (2) Release the MP sensor harness and the MP paper empty sensor harness from the securing fixtures.
- (3) Remove the Taptite bind B M4x12 screw. Remove the MP relay PCB ASSY, and disconnect each harness from the MP relay PCB ASSY.

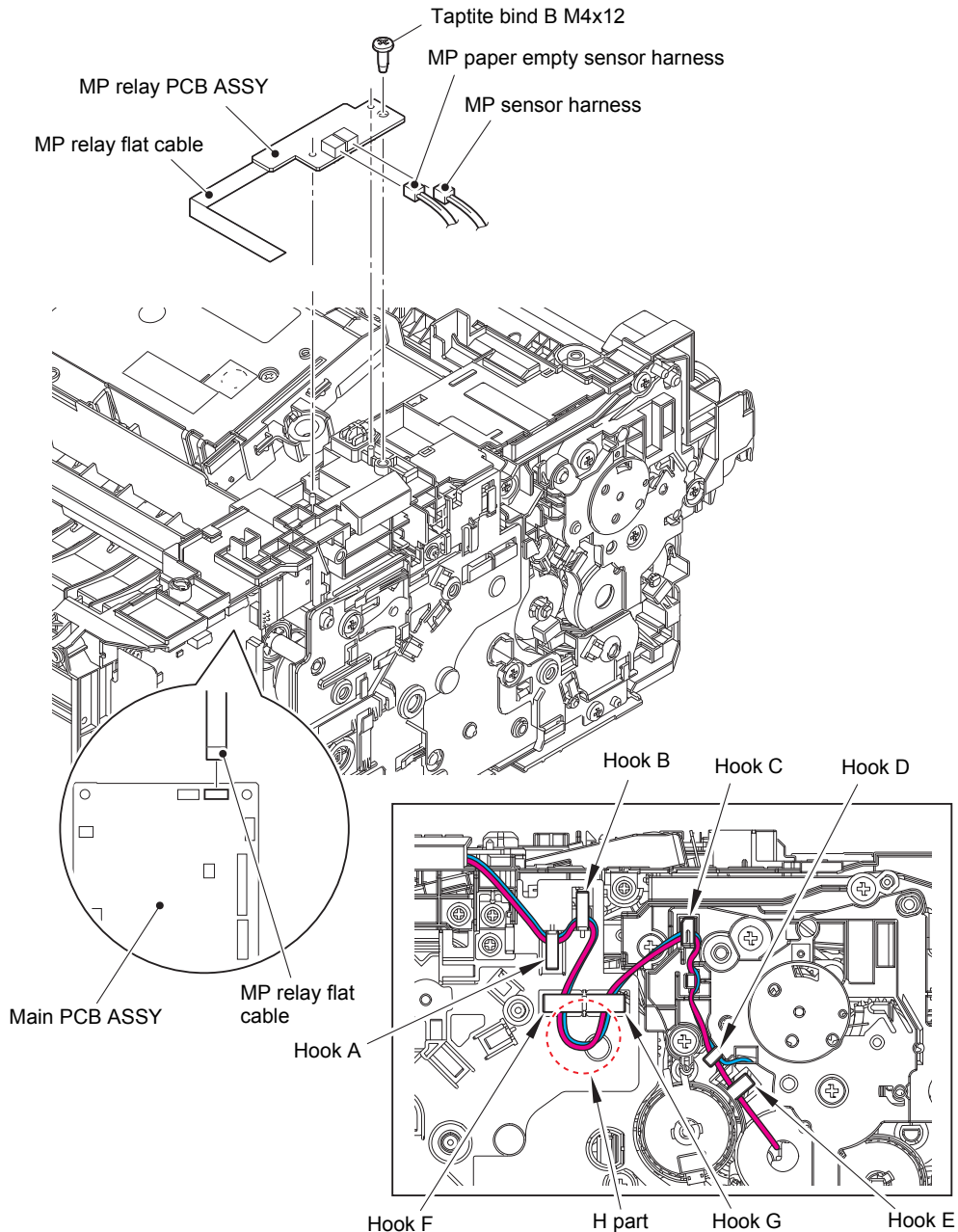


Fig. 3-75

Harness routing: Refer to "9. Top side of the machine", "11. Frame L unit (MP models)".

### Assembling Note:

- Secure each harness in the Hooks in order of the Hook A to E, and then secure them in the Hooks from the Hook F to G. Be sure to give them enough slack in the H part for adjustment.

## 9.24 Laser unit flat cable / Laser unit

- (1) Disconnect the Laser unit flat cable from the Main PCB ASSY and the Laser unit, and release it from the securing fixtures.

**Note:**

- After disconnecting flat cables, check that each cable is not damaged at its end or short-circuited.
- When connecting flat cables, do not insert them at an angle. After insertion, check that the cables are not at an angle.

- (2) Disconnect the Polygon motor harness from the Main PCB ASSY, and release it from the securing fixtures.
- (3) Remove the four Taptite cup S M3x8 SR screws to remove the Laser unit.

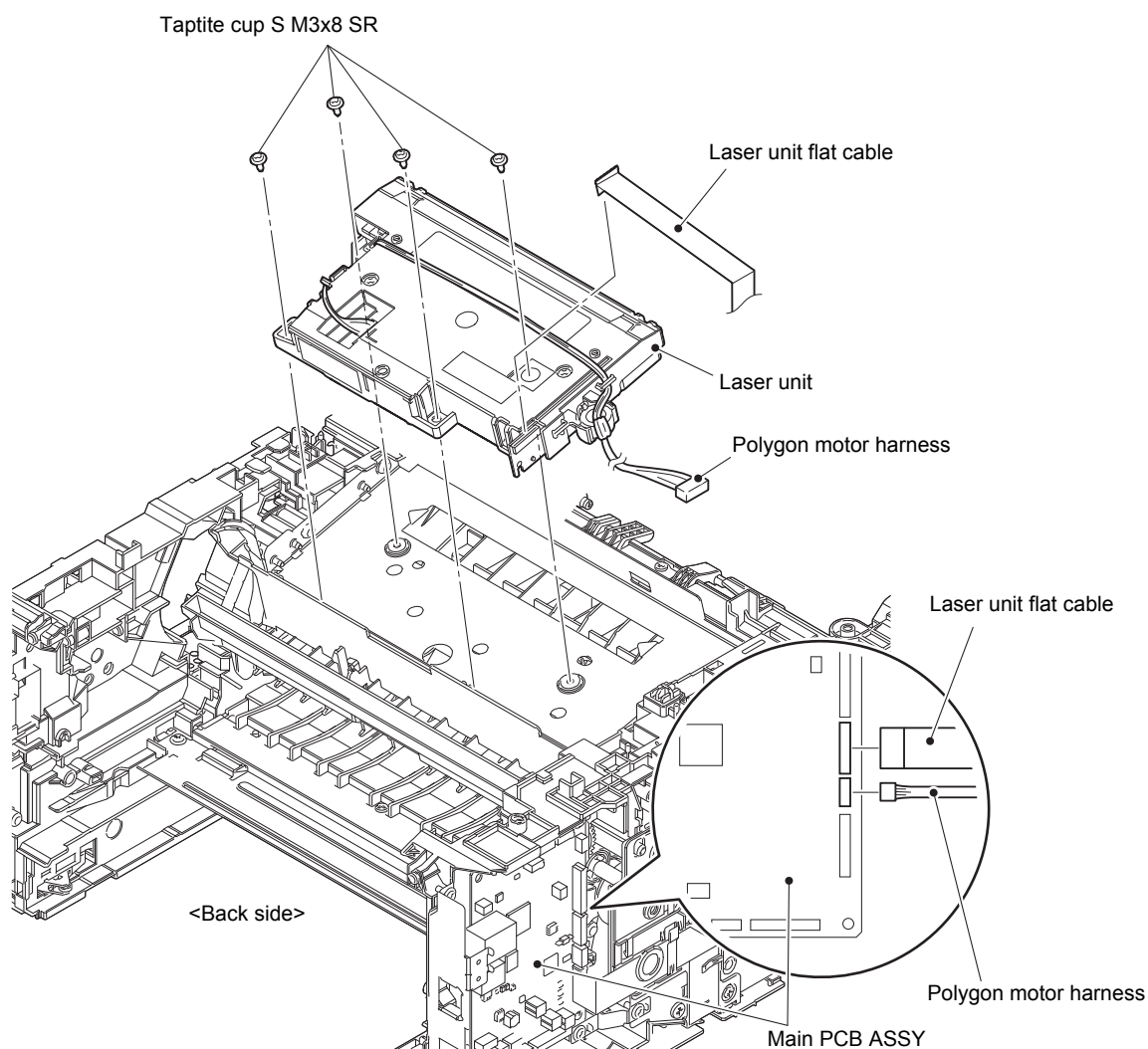
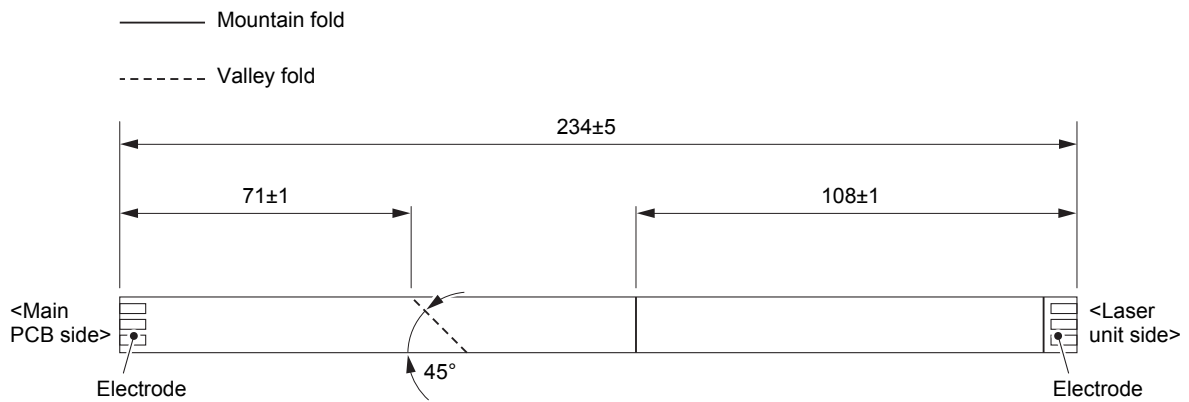


Fig. 3-76

Harness routing: Refer to "9. Top side of the machine", "10. Frame L unit (Manual feed models)".

**Assembling Note:**

- Fold the Laser unit flat cable at the positions described below.

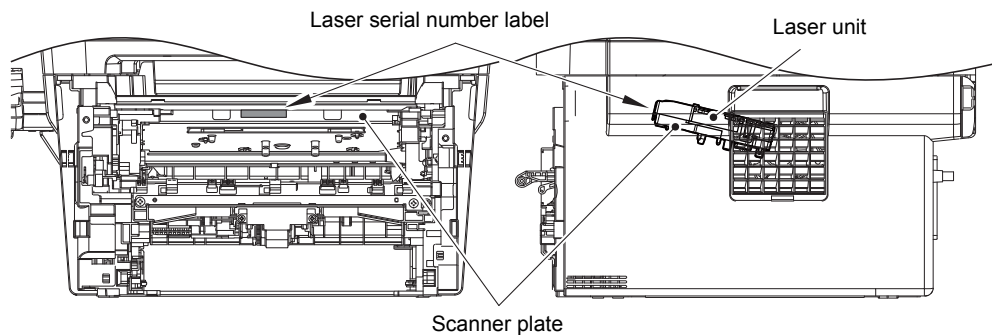


**Fig. 3-77**

**Assembling Note:**

- After the replacement, refer to "3. IF YOU REPLACE THE LASER UNIT" in Chapter 4 to enter the adjusted value of the Laser unit.

<How to identify the type of Laser unit and the position of the laser serial number label>



**Fig. 3-78**

**Assembling Note:**

- Attach the laser serial number label as shown in the figure above (on the Scanner plate) after replacing the Laser unit.

# 9.25 Filter

(1) Release the Hook to remove the Filter from the Air duct.

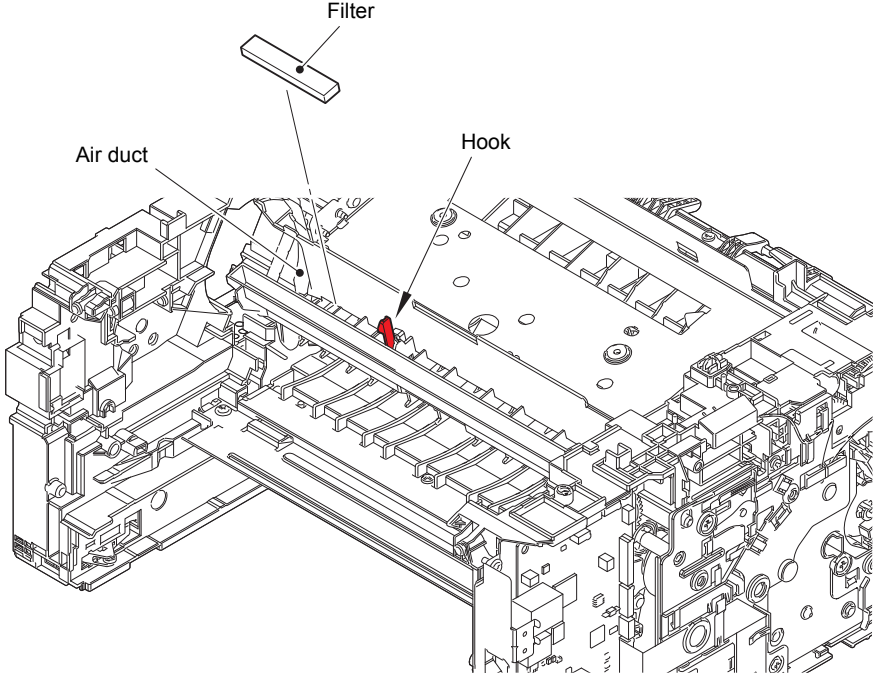


Fig. 3-79

## 9.26 Wireless LAN PCB (Only for wireless network models)

- (1) Remove the Tape on the Wireless LAN PCB, and disconnect the Wireless LAN PCB from the Main PCB ASSY.

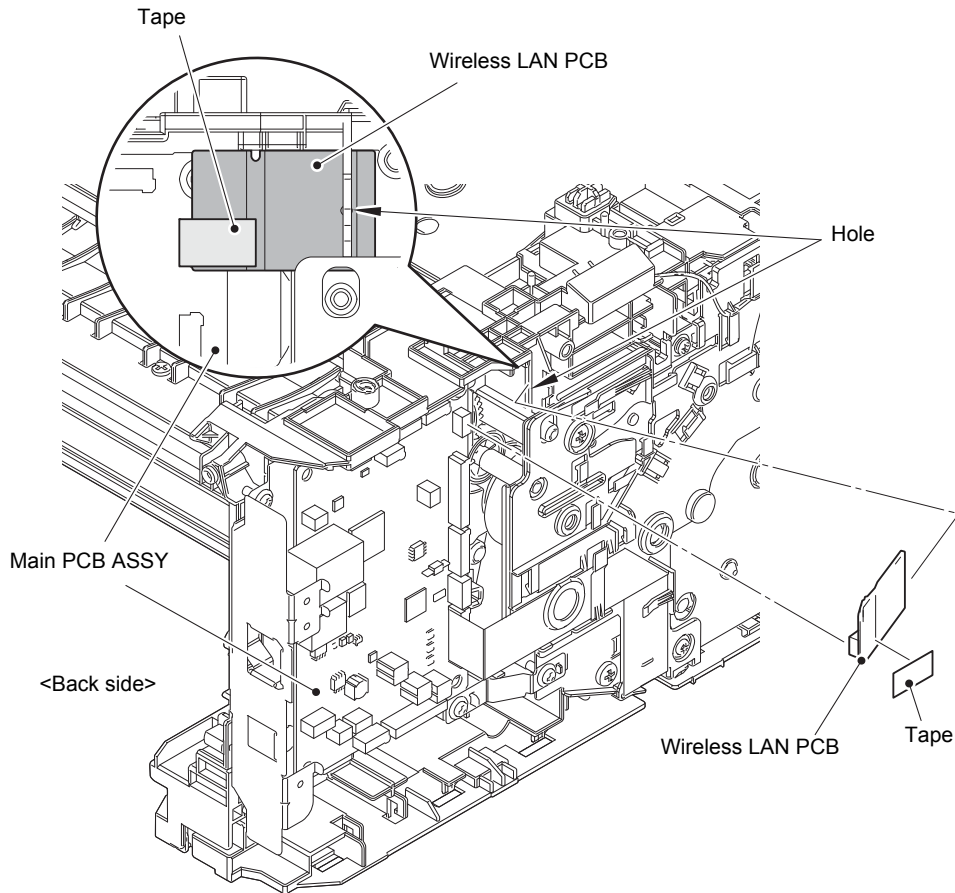


Fig. 3-80

### Assembling Note:

- When connecting the Wireless LAN PCB, insert the Wireless LAN PCB to the Hole on the machine, and connect the Wireless LAN PCB to the Main PCB ASSY.
- When assembling the Wireless LAN PCB, remove all the tapes on the Wireless LAN PCB. Also, do not attach a tape. These tapes are for securing the Wireless LAN PCB during the shipping, not required for usage. These tapes are special tape and using other tapes may cause short circuit between terminals.

## 9.27 Roller holder ASSY

- (1) Push the Link arm in the direction of the arrow A. Rotate the Roller holder ASSY, and release the Boss.
- (2) Slide the Roller holder ASSY in the direction of the arrow B, and remove it from the Shaft. Remove the Roller holder ASSY.

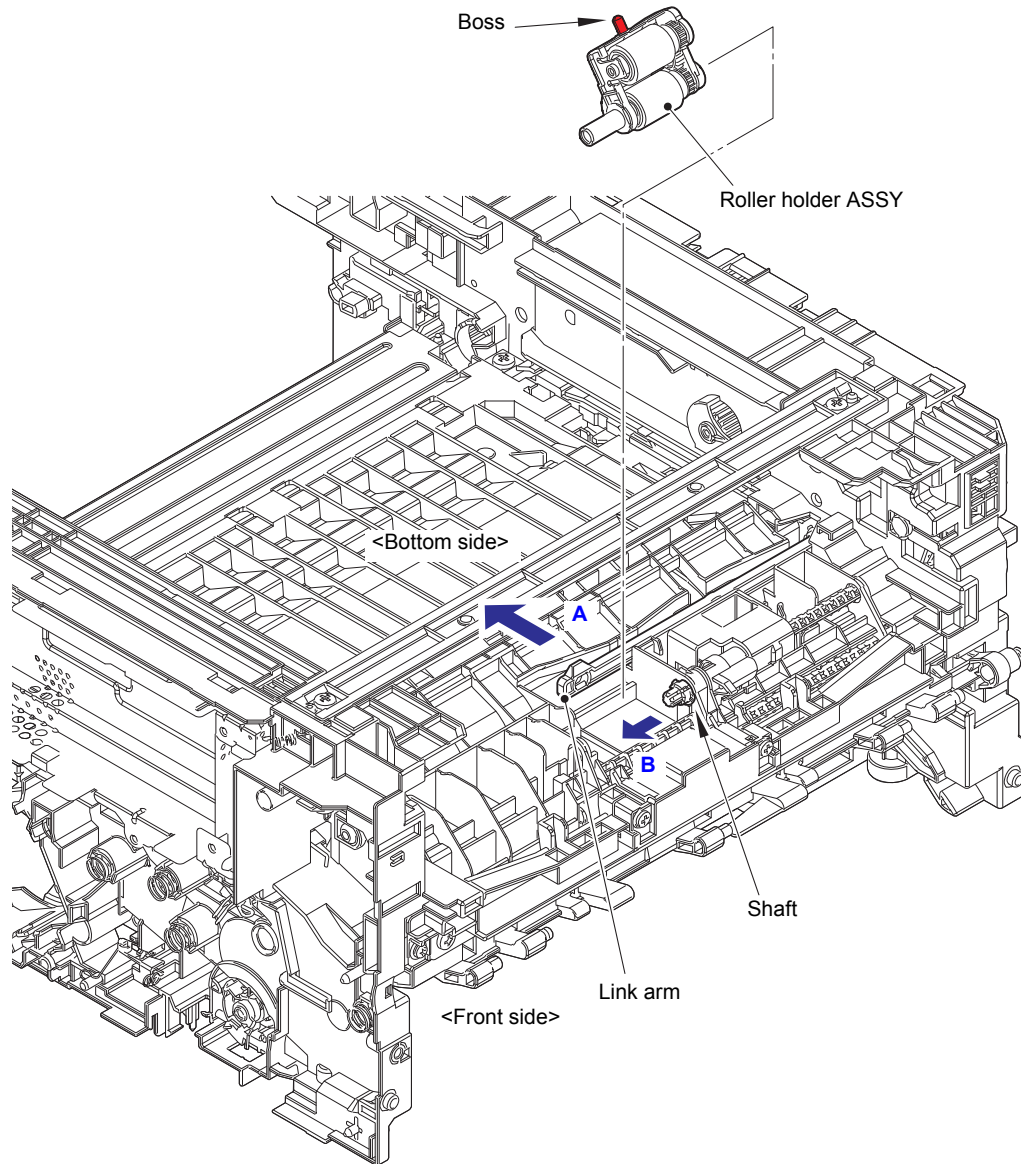


Fig. 3-81

## 9.28 Main PCB ASSY

- (1) Disconnect all harnesses and flat cables from the Main PCB ASSY.

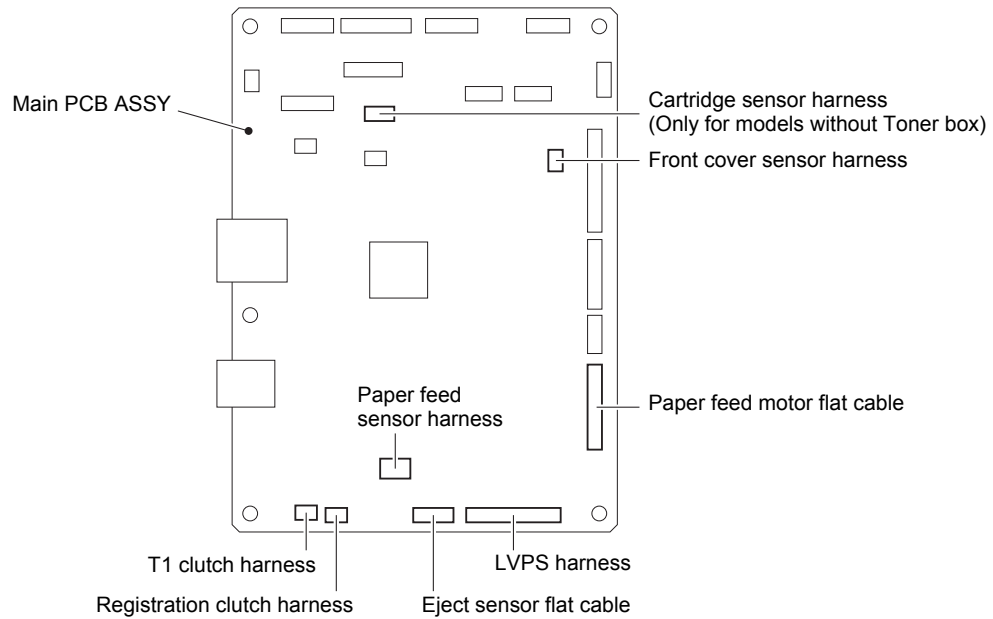


Fig. 3-82

Harness routing: Refer to "9. Top side of the machine", "10. Frame L unit (Manual feed models)".

- (2) Remove the two Screw cup M3x8 (black) screws, and remove the Main PCB FG plate 1.
- (3) Remove the four Screw cup M3x8 (black) screws, and remove the Main PCB ASSY.

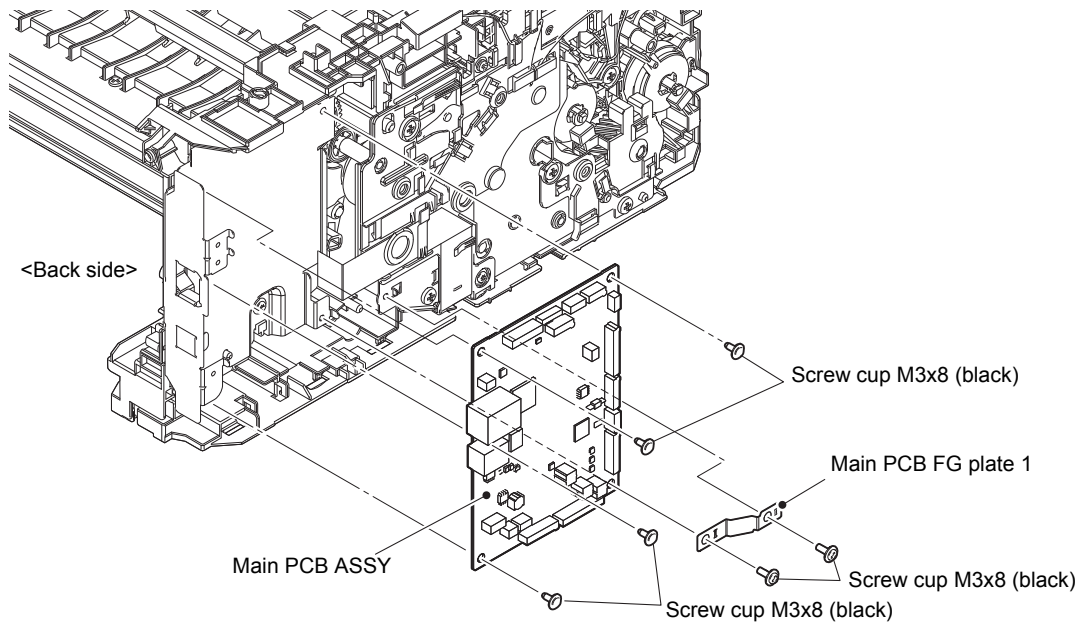


Fig. 3-83

### Assembling Note:

- After the replacement, refer to "1. IF YOU REPLACE THE MAIN PCB ASSY" in Chapter 4 to enter the adjusted value of the Main PCB ASSY.



## 9.29 T1 clutch / Registration clutch

### ■ Manual feed models

- (1) Release the T1 clutch harness and the Registration clutch harness from the securing fixtures.
- (2) Release the Hook, and remove the T1 clutch.
- (3) Release the Hook, and remove the Registration clutch.

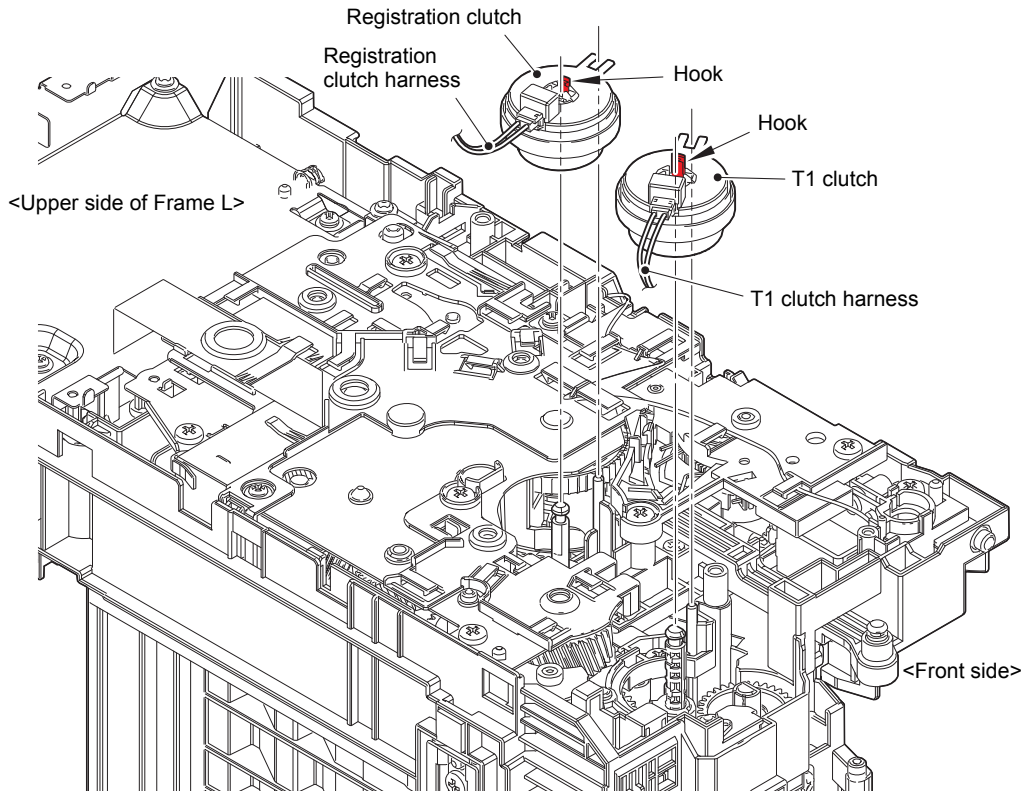


Fig. 3-84

Harness routing: Refer to "10. Frame L unit (Manual feed models)".

#### Assembling Note:

- When securing the T1 clutch harness and the Registration clutch harness, check that there is no harness slack.
- Attach the Rotation stoppers of the T1 clutch and the Registration clutch by engaging them with the Pins of the machine as shown in the figure below.

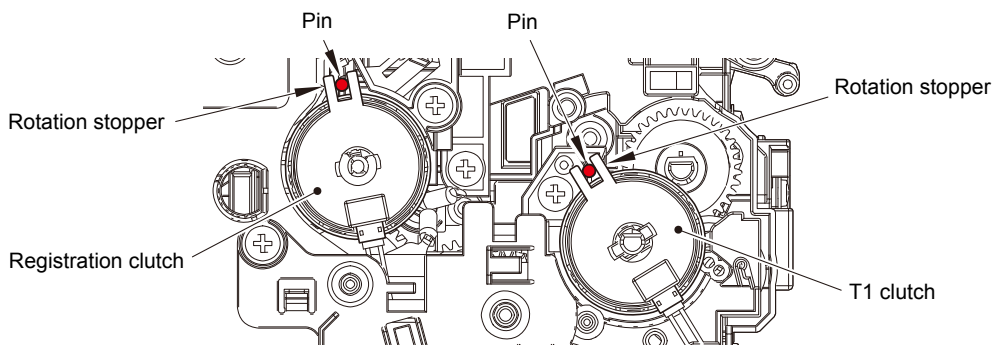
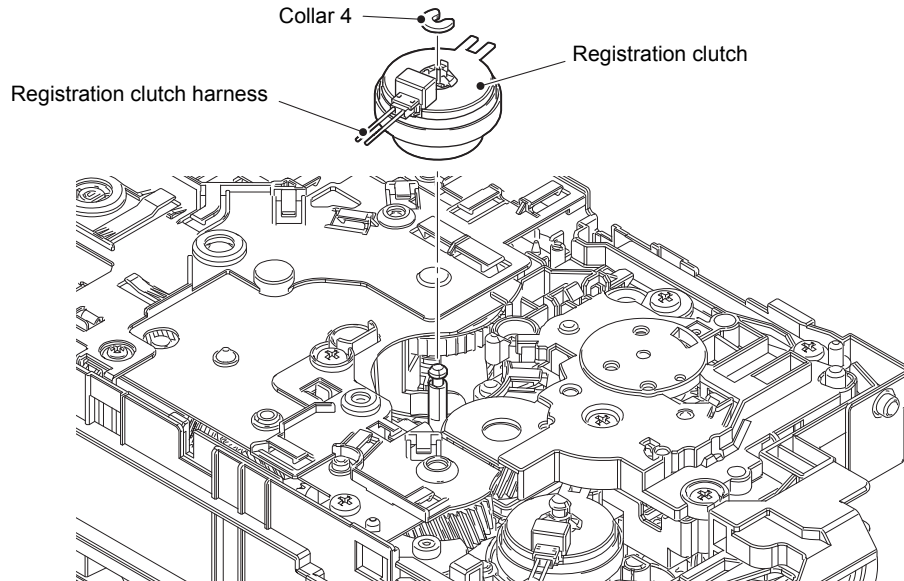


Fig. 3-85



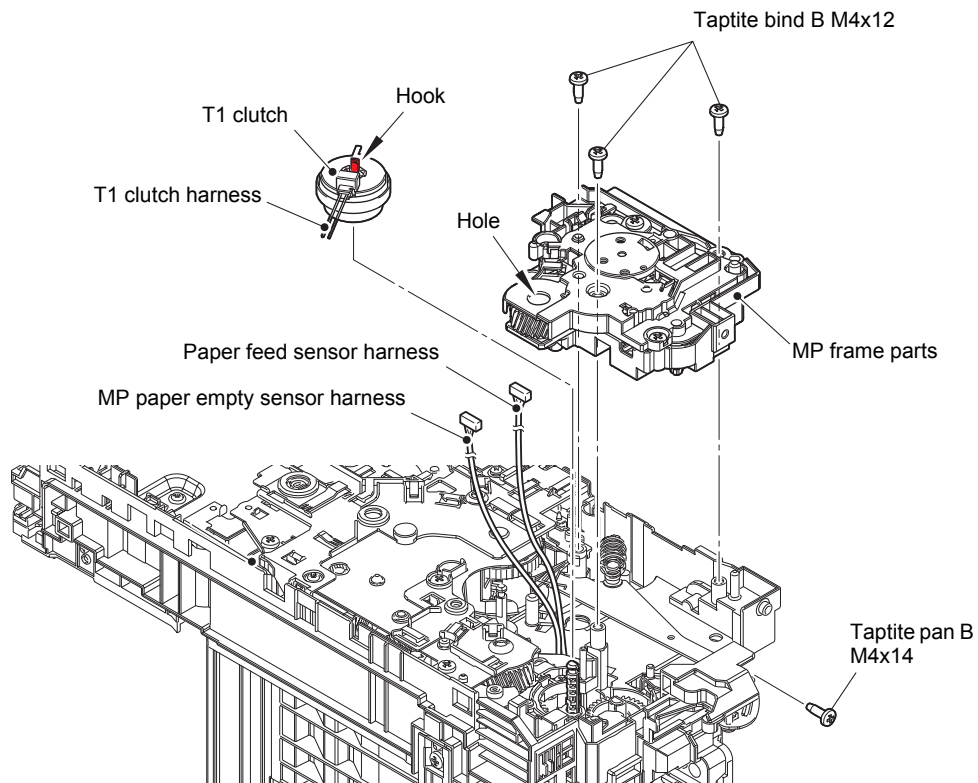
■ **MP models**

- (1) Release the Registration clutch harness from the securing fixtures.
- (2) Remove the Collar 4 to remove the Registration clutch.



**Fig. 3-86**

- (3) Release the T1 clutch harness and the Paper feed sensor harness from the securing fixtures.
- (4) Remove the three Taptite bind B M4x12 screws and the Taptite pan B M4x14 screw to remove the MP frame parts. Pull out the Paper feed sensor harness and the MP paper empty sensor harness from the hole of the MP frame parts.
- (5) Release the Hook, and remove the T1 clutch.

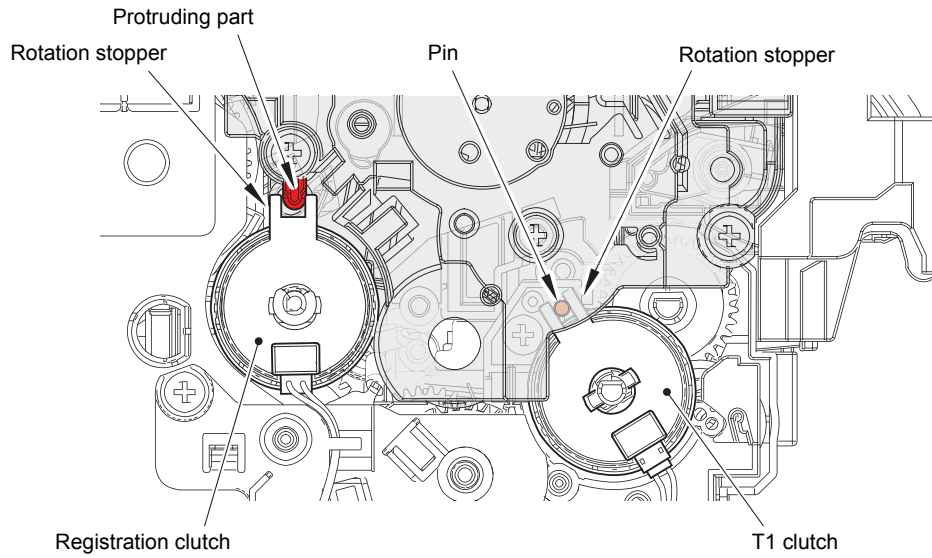


**Fig. 3-87**

Harness routing: Refer to "11. Frame L unit (MP models)".

**Assembling Note:**

- When securing the T1 clutch harness and the Registration clutch harness, check that there is no harness slack.
- Attach the Rotation stopper of the T1 clutch by engaging it with the Pin of the machine as shown in the figure below.
- Attach the Rotation stopper of the Registration clutch by engaging it with the Protruding part of the machine as shown in the figure below.



**Fig. 3-88**

## 9.30 Frame L unit

### Manual feed models

- (1) Remove the two Taptite bind B M4x12 screws and the Screw pan (S/P washer) M3x12DB screw, and remove the Front chute ASSY.
- (2) Release the LVPS harness, the Cartridge sensor harness (only for models without Toner box) and the Paper feed sensor harness from the securing fixtures.
- (3) Remove the Regist FG spring from the Motor drive sub ASSY and the Conductive bushing 5.
- (4) Use a flat-blade screwdriver or similar tool to release the Hook from the Hole, and remove the Conductive bushing 5.
- (5) Release the Hook, and remove the Feeder gear 34.

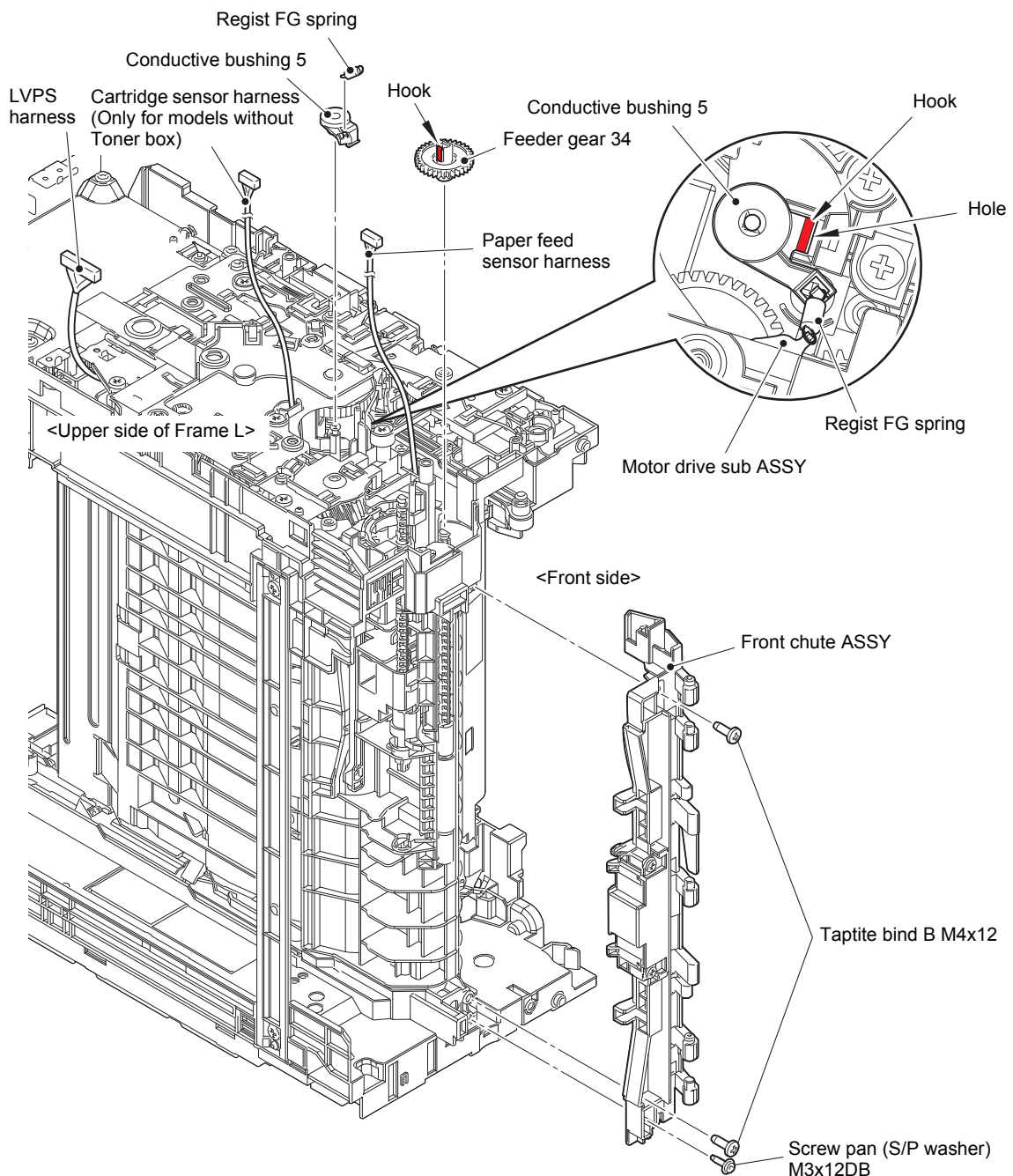
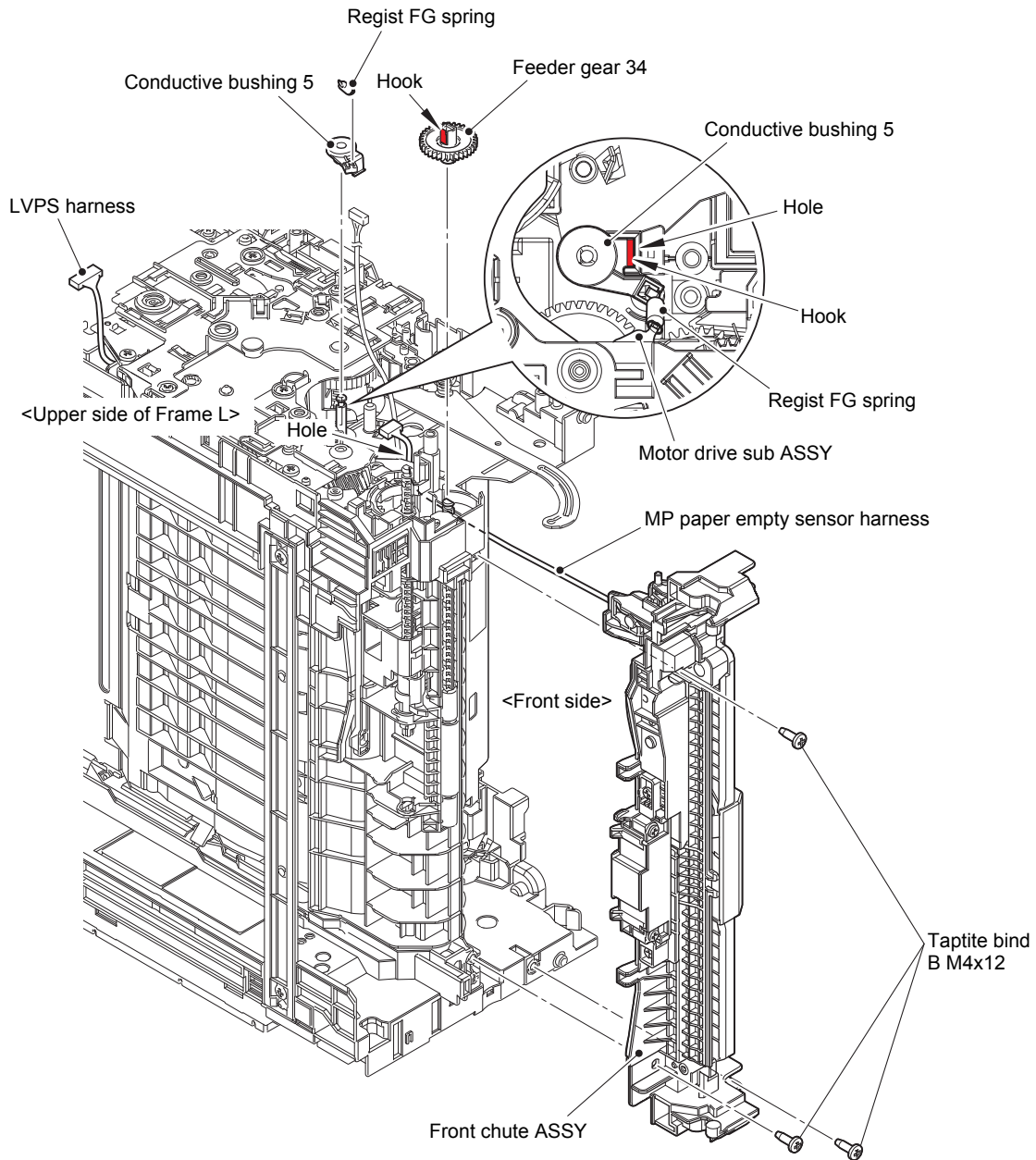


Fig. 3-89

Harness routing: Refer to "10. Frame L unit (Manual feed models)".

■ **MP models**

- (6) Remove the three Taptite bind B M4x12 screws to remove the Front chute ASSY. Pull out the MP paper empty sensor harness from the Hole of the Frame L unit.
- (7) Release the LVPS harness from the securing fixtures.
- (8) Remove the Regist FG spring from the Motor drive sub ASSY and the Conductive bushing 5.
- (9) Use a flat-blade screwdriver or similar tool to release the Hook from the Hole, and remove the Conductive bushing 5.
- (10) Release the Hook, and remove the Feeder gear 34.



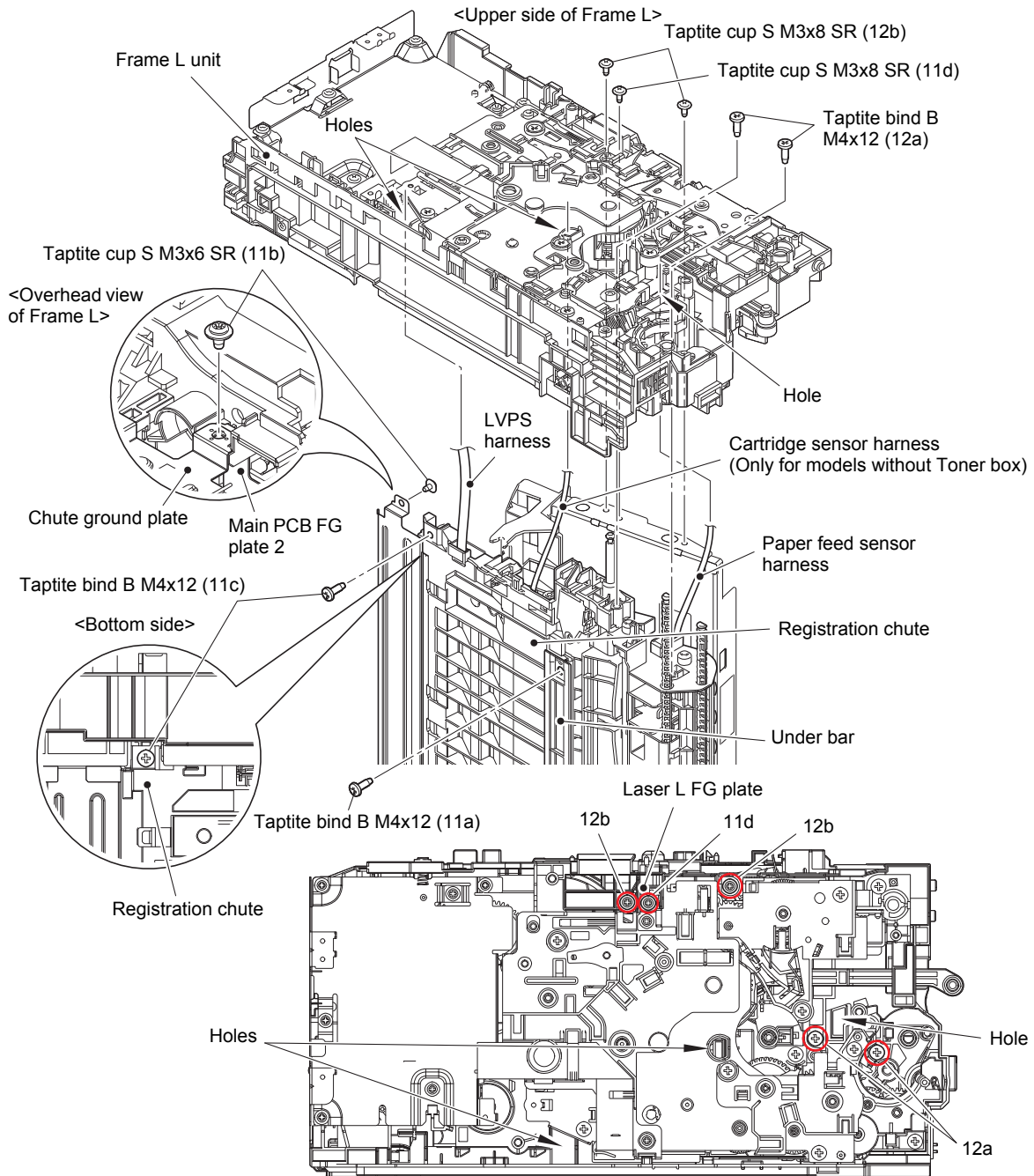
**Fig. 3-90**

Harness routing: Refer to "11. Frame L unit (MP models)".

■ **Common to all models**

(11) Remove the Taptite bind B M4x12 (11a) screw (for securing the Under bar), the Taptite cup S M3x6 SR (11b) screw (for securing the Chute ground plate), the Taptite bind B M4x12 (11c) screw (for securing the Registration chute), and the Taptite cup S M3x8 SR (11d) screw (for securing the Laser L FG plate).

(12) Remove the two Taptite bind B M4x12 (12a) screws and the two Taptite cup S M3x8 SR (12b) screws, and remove the Frame L unit. Pull out the Paper feed sensor harness, the Cartridge sensor harness (only for models without Toner box) and the LVPS harness from the Holes.



**Fig. 3-91**

Harness routing: Refer to “10. Frame L unit (Manual feed models)”.

**Assembling Note:**

- When assembling the Frame L unit, make sure that the Chute ground plate is above the Main PCB FG plate 2.



## 9.31 Paper feed motor / Paper feed motor flat cable

- (1) Release the Paper feed motor flat cable and the Front cover sensor harness from the securing fixtures.
- (2) Remove the Taptite bind B M4x12 screw. Release the Hook, and slide the Flat cable guide in the direction of the arrow to remove it from the Motor drive sub ASSY.
- (3) Remove the Screw pan (S/P washer) M3x12DB, and remove the Laser L FG plate from the Motor drive sub ASSY.
- (4) Remove the three Taptite bind B M4x12 screws and the Taptite cup S M3x8 SR screw, and remove the Motor drive sub ASSY from the Frame L unit.

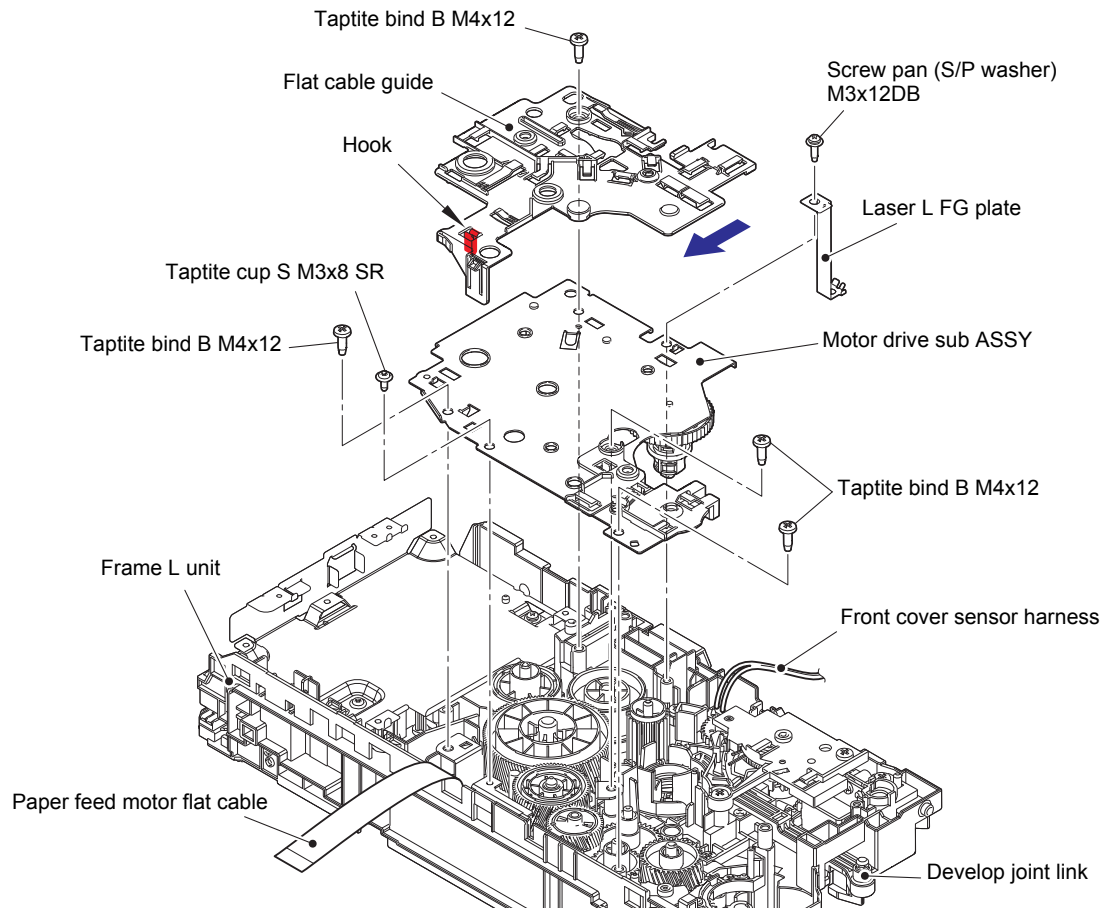


Fig. 3-92

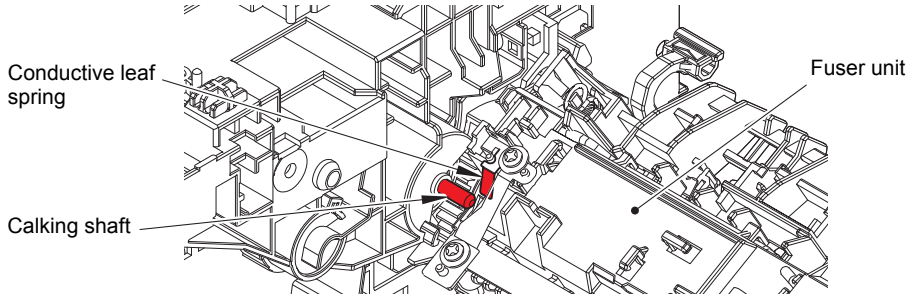
Harness routing: Refer to "10. Frame L unit (Manual feed models)".

### Assembling Note:

- Be careful not to bend the Laser L FG plate.
- Attach the Motor drive sub ASSY to the Frame L unit while the Develop joint link is pushed. Pull the Develop joint link back before tightening the screws for the Motor drive sub ASSY. Failure to follow the procedure above may get the Develop joint link caught and jammed.

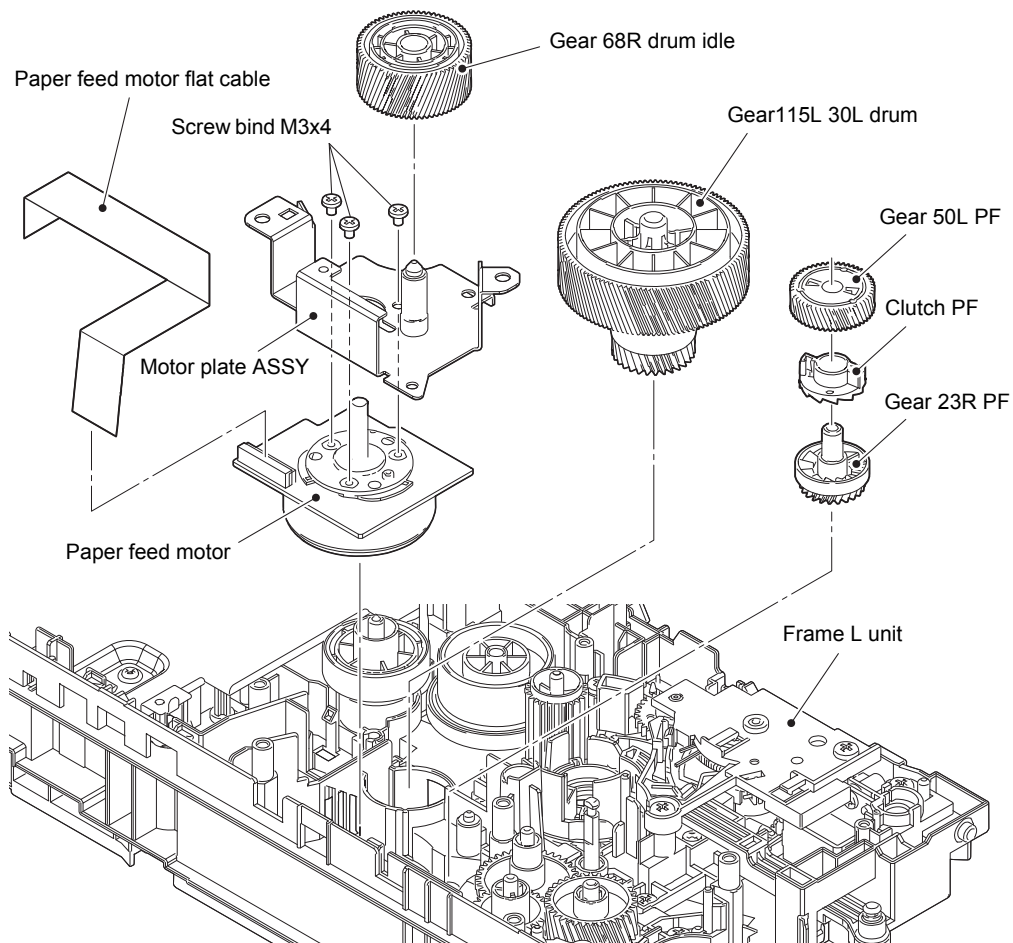
**Assembling Note:**

- If you removed the Motor drive sub ASSY while the Fuser unit was attached on the machine, remove the Fuser unit once (refer to "9.18 Fuser unit") and reattach it after attaching the Motor drive sub ASSY.  
The Conductive leaf spring of the Fuser unit may be deformed by the Calking shaft. If they are not in contact properly, a ghost may occur in the printed image.



**Fig. 3-93**

- (5) Remove the Gear115L 30L drum, the Gear 50L PF, the Clutch PF, and the Gear 23R PF from the Frame L unit.
- (6) Remove the Gear 68R drum idle from the Motor plate ASSY, and remove the Motor plate ASSY from the Frame L unit.
- (7) Remove the three Screw bind M3x4 screws, and remove the Paper feed motor from the Motor plate ASSY.
- (8) Disconnect the Paper feed motor flat cable from the Paper feed motor.



**Fig. 3-94**

# 9.32 Fuser gear 64R/36R

(1) Remove the Fuser gear 64R/36R from the Frame L unit.

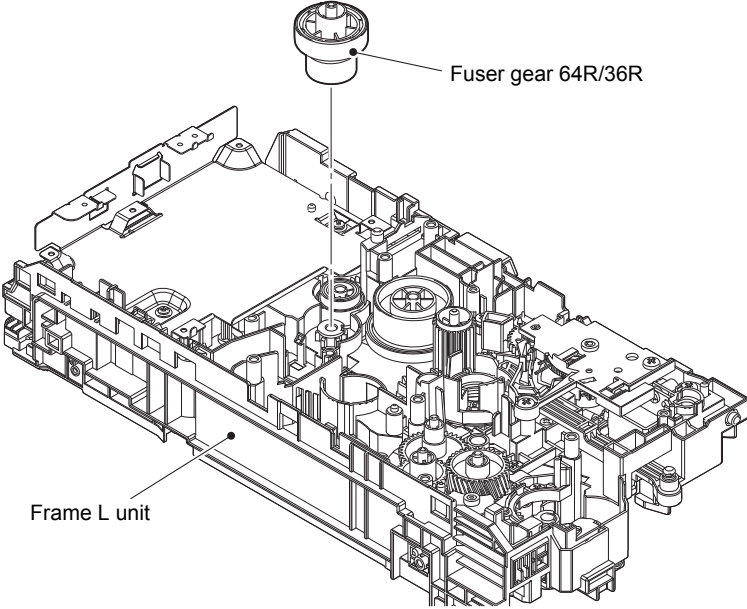


Fig. 3-95



## 9.33 Toner sensor PCB ASSY (Only for models with Toner box)

- (1) Release the Toner box solenoid harness and the Toner sensor harness from the securing fixtures.
- (2) Remove the two Taptite bind B M4x12 screws. Release the Hook to remove the Toner box drive cover from the Frame L unit. Pull out the Toner sensor harness from the Hole.
- (3) Slide the Develop joint link in the direction of the arrow. Remove the Develop joint disk from the Develop joint lift cover. Release the Hook of the Develop joint link to remove the Develop joint lift cover.
- (4) Remove the Develop joint link from the Frame L unit.
- (5) Remove the Taptite bind B M3x8 screw to remove the Film and the Toner sensor PCB ASSY.

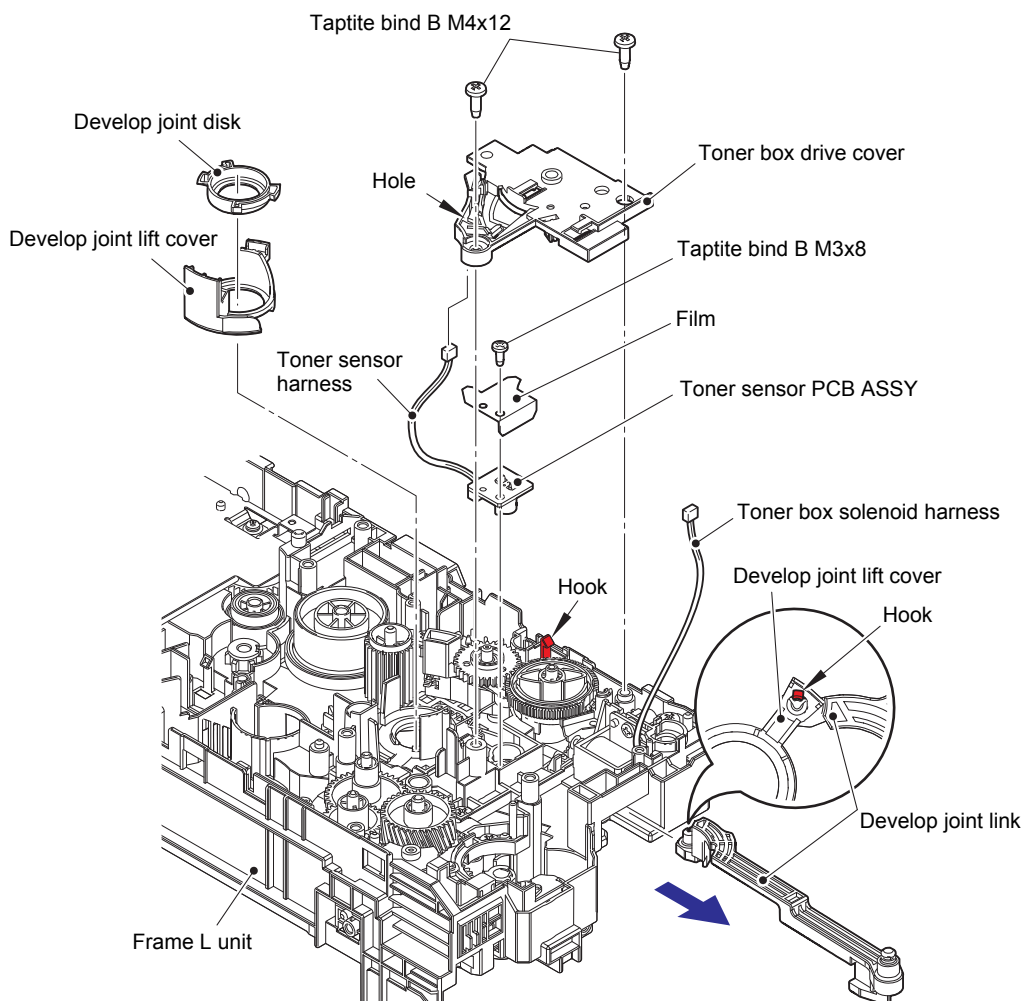


Fig. 3-96

Harness routing: Refer to "10. Frame L unit (Manual feed models)".

## 9.34 Front cover sensor

- (1) Remove the Gear toner box idle 32 and the Sector gear toner box from the Holder toner box. (Only for models with Toner box)
- (2) Remove the Spring sector gear toner box from the Hook of Holder toner box and the Hook of Lever solenoid. (Only for models with Toner box)
- (3) Remove the four Taptite bind B M4x12 screws, and remove the Holder toner box and the Lift cam guide from the Frame L unit. (For models with Toner box)  
Remove the two Taptite bind B M4x12 screws, and remove the Lift cam guide from the Frame L unit. (For models without Toner box)
- (4) Release each Hook to remove the Front cover sensor from the Frame L unit.

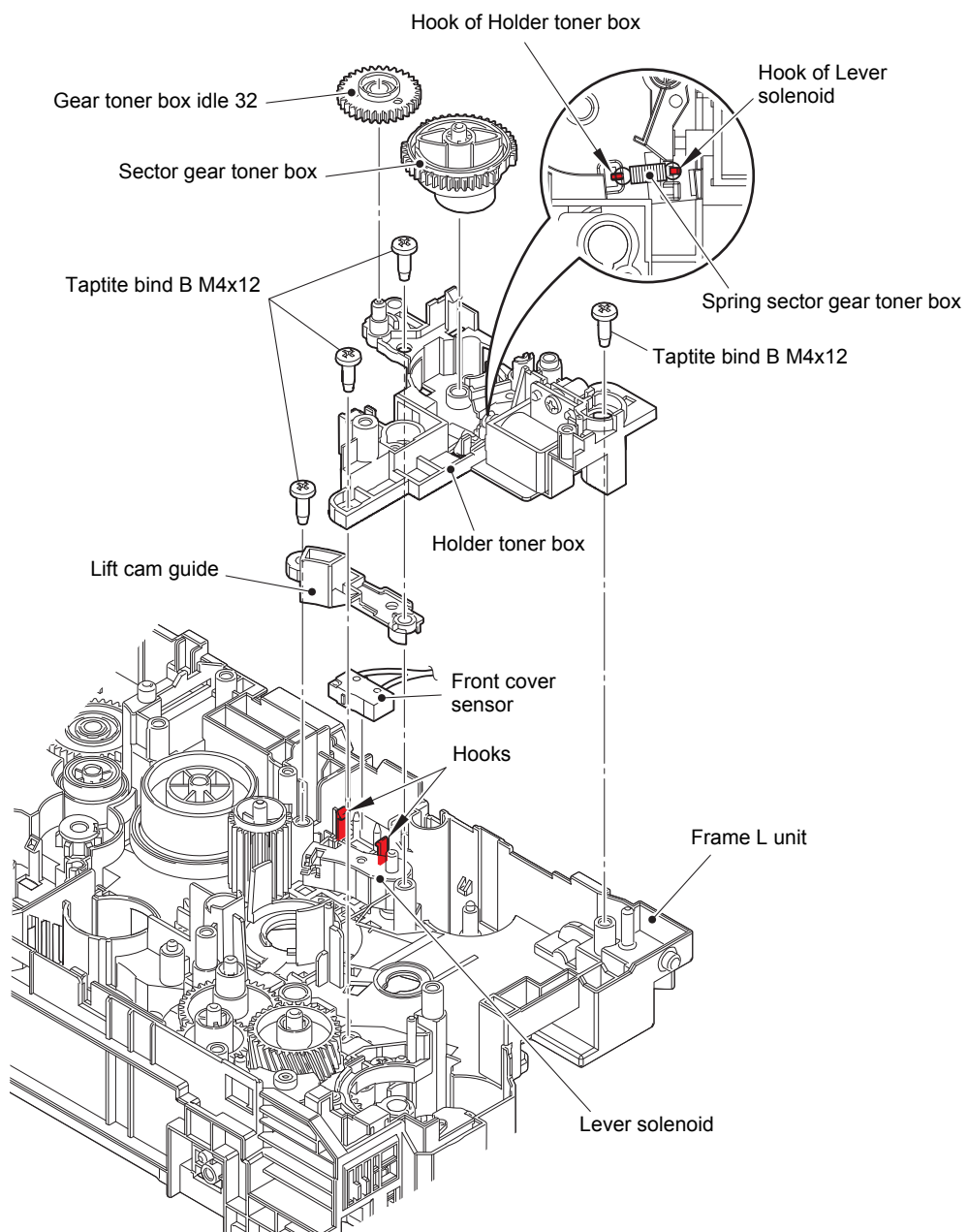


Fig. 3-97

## 9.35 Eject sensor PCB ASSY

- (1) Remove the Taptite cup S M3x8 SR screw and the Screw pan (S/P washer) M3x12DB screw. Lift the upper side of the Main shield plate up to remove it from the Pin, and pull out the Main shield plate in the direction of the arrow to remove it from the Rib of the Frame L unit.

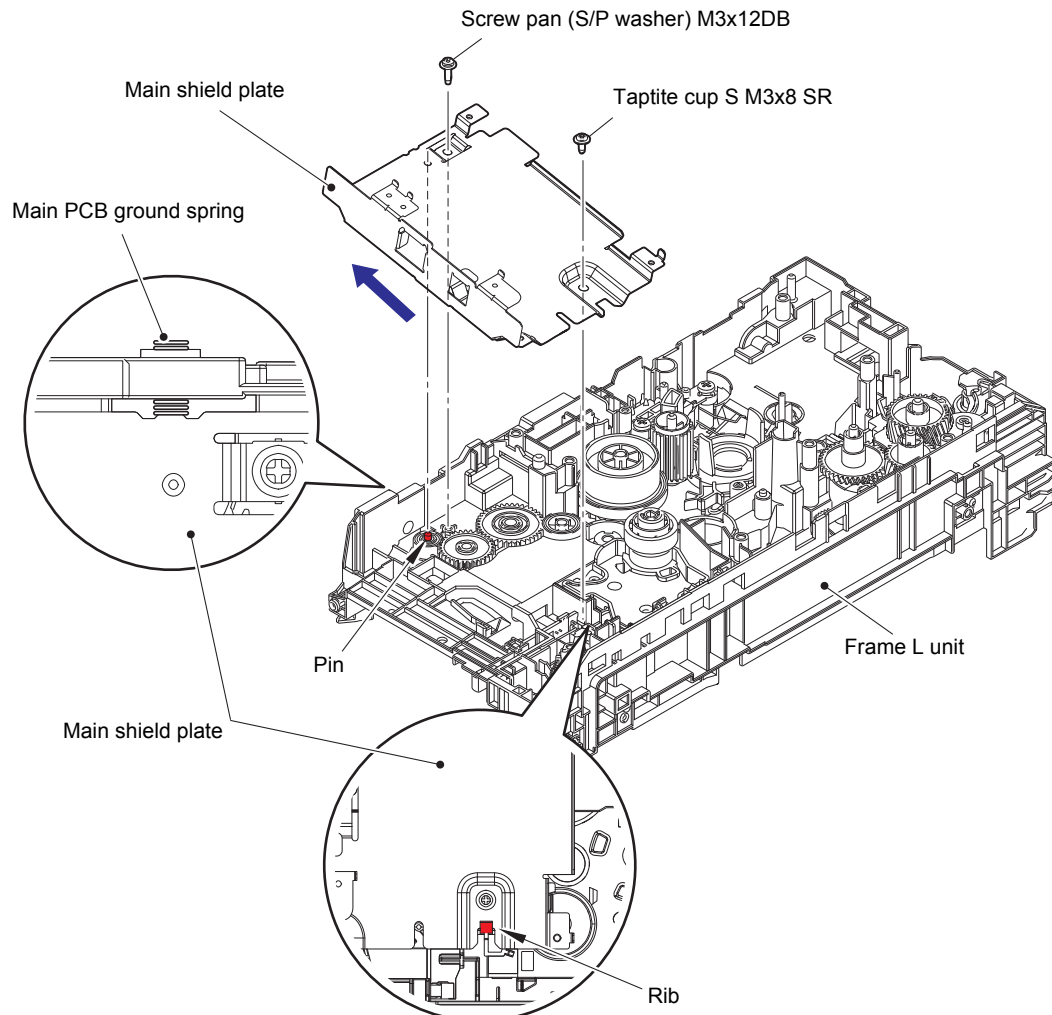
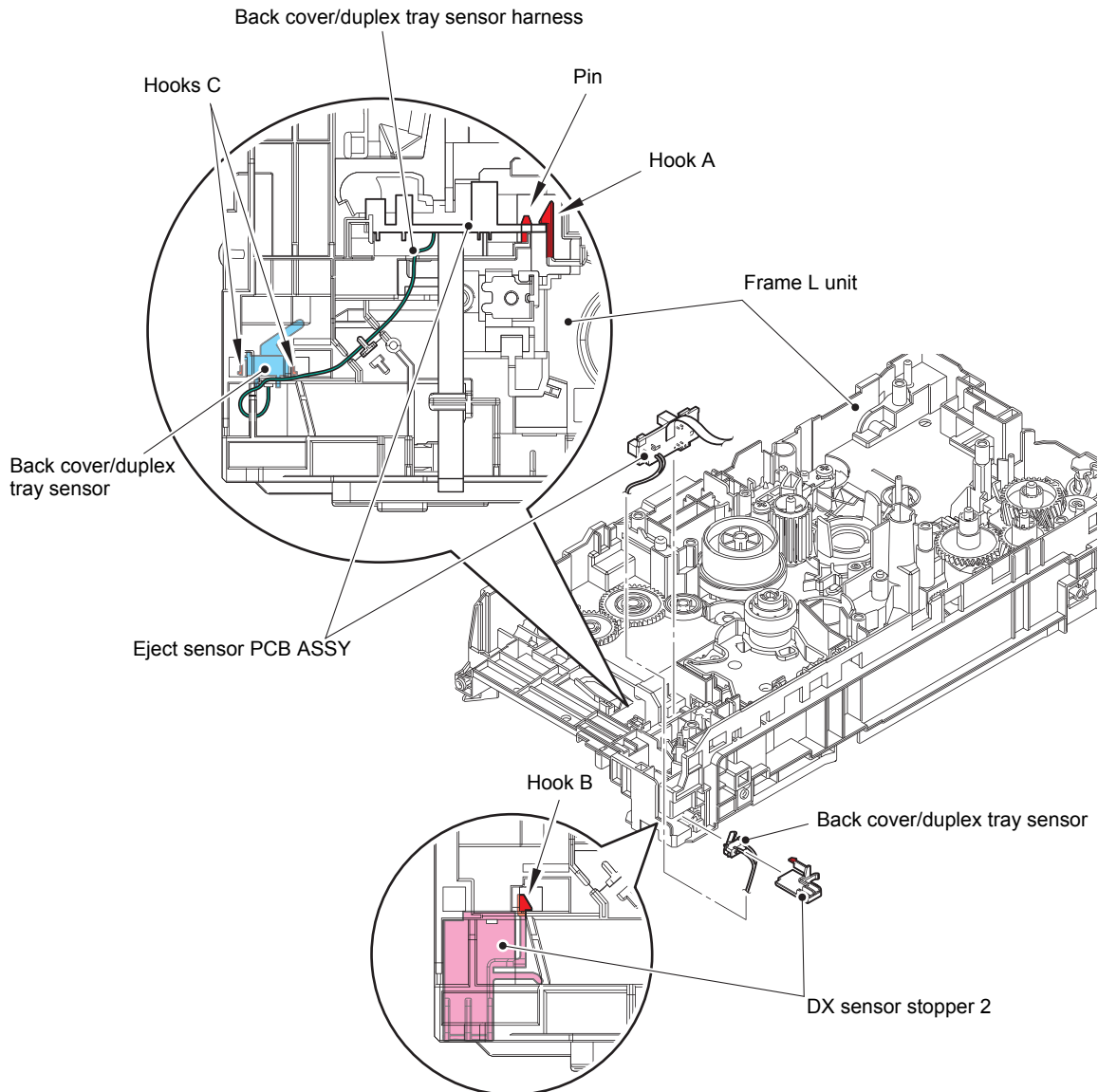


Fig. 3-98

### Assembling Note:

- When assembling the Main shield plate, check that the Main PCB ground spring is not inclined. Attach it correctly as shown in the figure above.
- If you removed the Main shield plate while the Fuser unit was attached on the machine, release the Side thermistor harness ASSY and the Center thermistor harness ASSY from the securing fixture of the Frame L unit. Then tighten the screw for the Main shield plate and secure each harness in the securing fixture. If the Main shield plate is assembled while the Fuser unit is attached to the machine, the Side thermistor harness ASSY and the Center thermistor harness ASSY may be caught.

- (2) Release the Hook A, and remove the Eject sensor PCB ASSY from the Pin of the Frame L unit.
- (3) Release the Back cover/duplex tray sensor harness from the securing fixtures.
- (4) Release the Hook B, and remove the DX sensor stopper 2 from the Frame L unit.
- (5) Release each Hook C, and remove the Back cover/duplex tray sensor from the Frame L unit.



**Fig. 3-99**

Harness routing: Refer to "10. Frame L unit (Manual feed models)".

**Assembling Note:**

- When assembling the Back cover/duplex tray sensor, attach it by engaging the Hooks C of the Back cover/duplex tray sensor properly.

# 9.36 Registration front/rear actuator holder ASSY

**Note:**

- As the Under bar is easy to bend, be careful to handle it.

- (1) Release the Hook part of the Under R FG wire from the LVPS shield plate.
- (2) Raise the Laser R FG plate slightly to remove it from the Pin.
- (3) Remove the Taptite cup S M3x8 SR screw and the Taptite bind B M4x12 screw, pull out the right side of the LVPS shield plate in the direction of the arrow A to remove it from the Pin. And then pull it out in the direction of the arrow B to remove it from the machine.

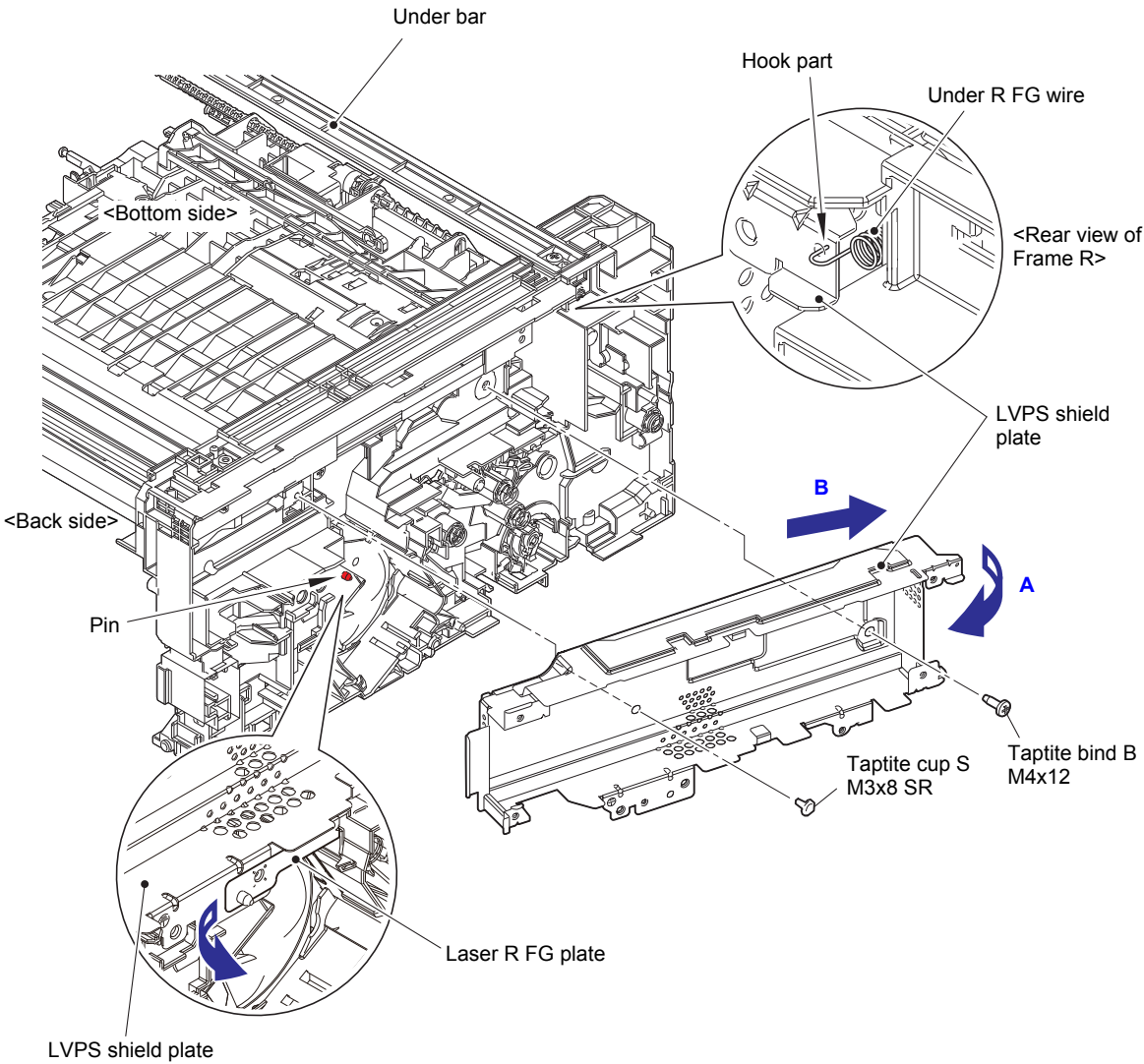
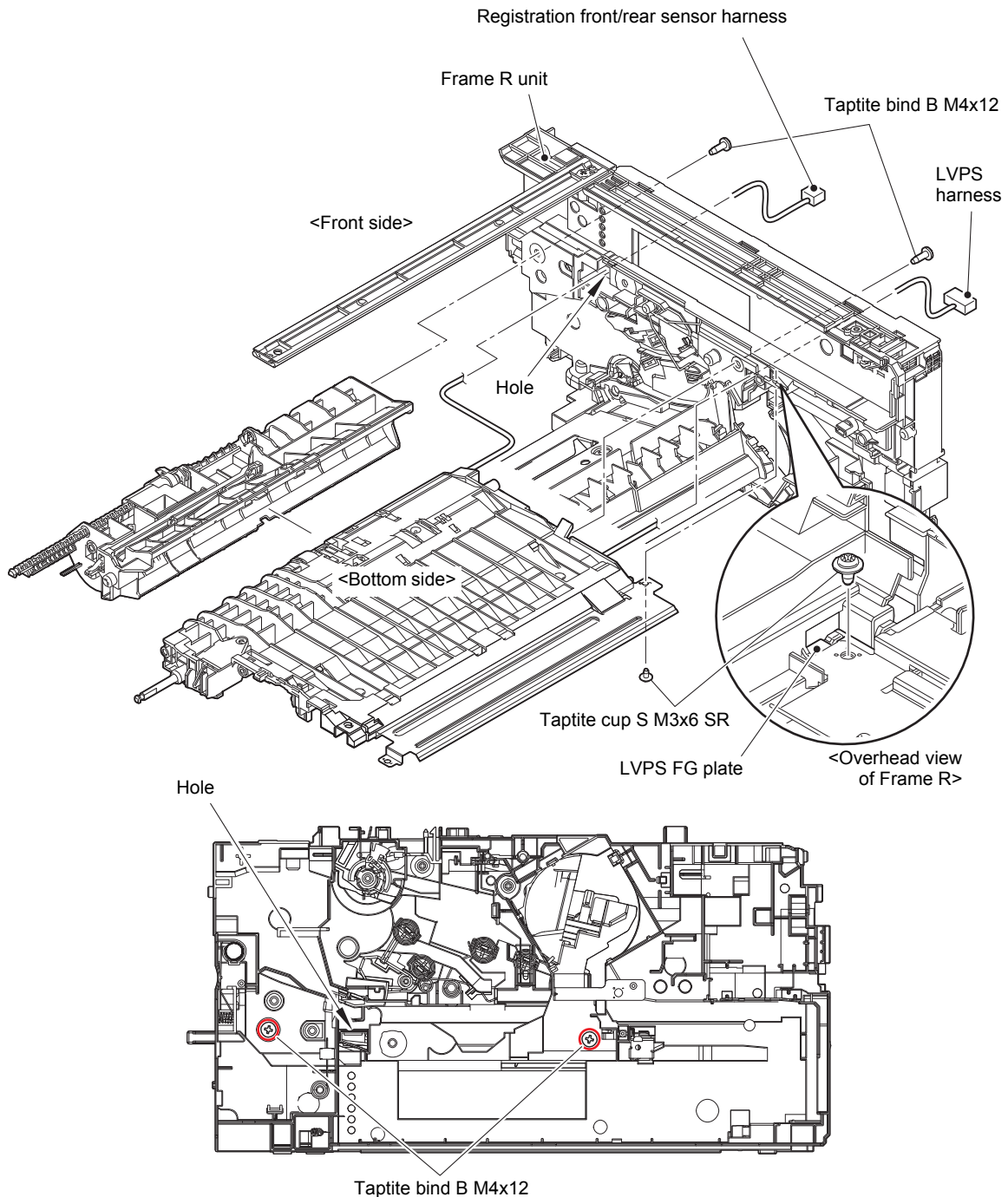


Fig. 3-100

- (4) Release the Registration front/rear sensor harness and the LVPS harness from the securing fixtures.
- (5) Remove the Taptite cup S M3x6 SR screw and the two Taptite bind B M4x12 screws to remove the Frame R unit. Pull out the Registration front/rear sensor harness from the Hole.



**Fig. 3-101**

Harness routing: Refer to "12. Top side of the registration chute", "13. Frame R unit".

**Assembling Note:**

- When attaching the Frame R unit, check that the LVPS FG plate is set to the Frame R unit.



- (6) Remove the Taptite bind B M3x10 screw. Release each Hook, and remove the Registration front/rear actuator holder ASSY from the Registration chute. Pull out the Registration front/rear sensor harness from the Hole.

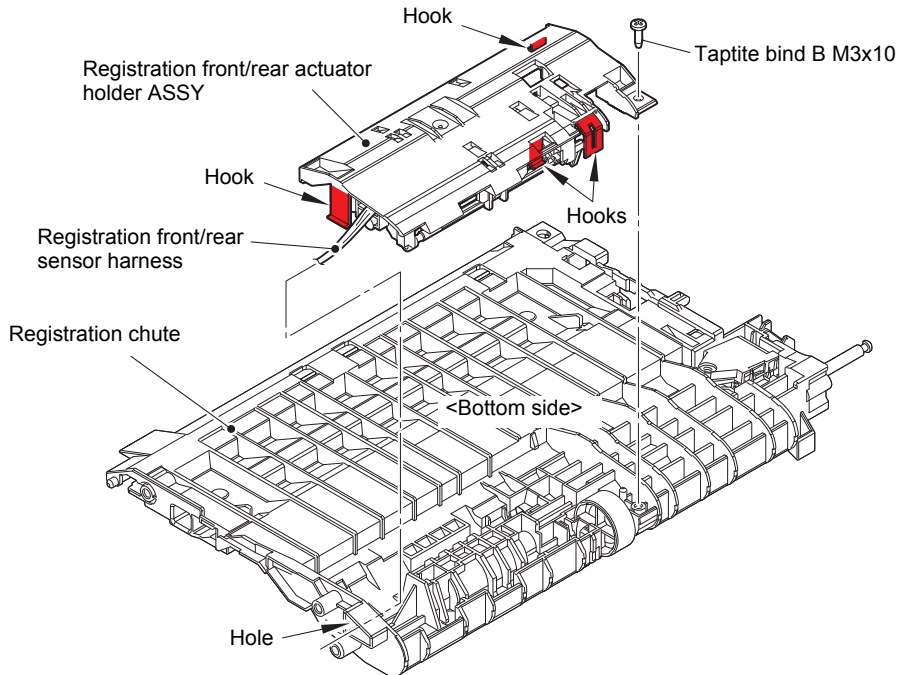


Fig. 3-102

Harness routing: Refer to "12. Top side of the registration chute".

**Assembling Note:**

- After assembling the Registration front/rear actuator holder ASSY to the Registration chute, push the Actuators by fingers and check if they are pushed back by their springs (if the springs are not caught at assembling).

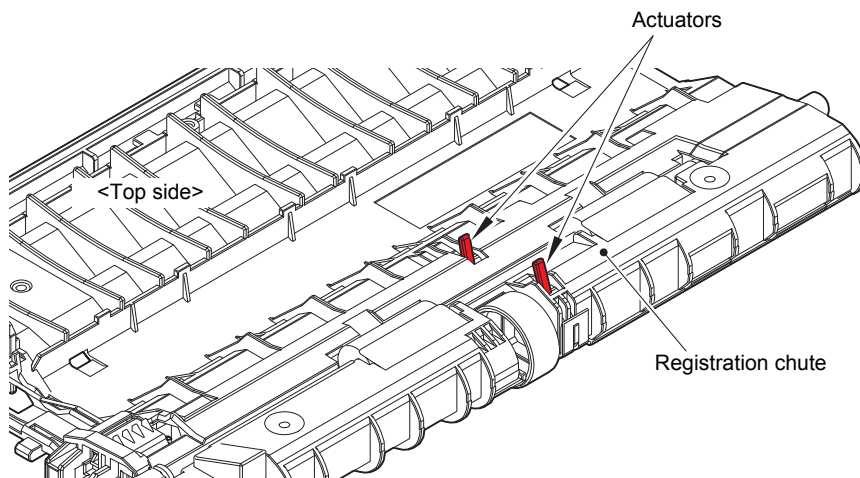


Fig. 3-103

## 9.37 Paper feed roller ASSY / Paper feed sensor PCB ASSY

- (1) Release each Hook of the Paper feed sensor cover to remove the Paper feed sensor cover.
- (2) Remove the Paper feed actuator spring from the Hook of the Paper feed actuator and the Hook of the Paper feed frame ASSY.
- (3) Release the Hook of the Separation R shaft bearing to remove the Separation R shaft and the Paper feed actuator.
- (4) Release each Hook of the two Feed roller bushings, and remove the Paper feed roller ASSY from the Paper feed frame ASSY in the direction of the arrow.
- (5) Release the Hook A to remove the Paper feed sensor PCB ASSY. Release the Paper feed sensor harness from the securing fixtures.

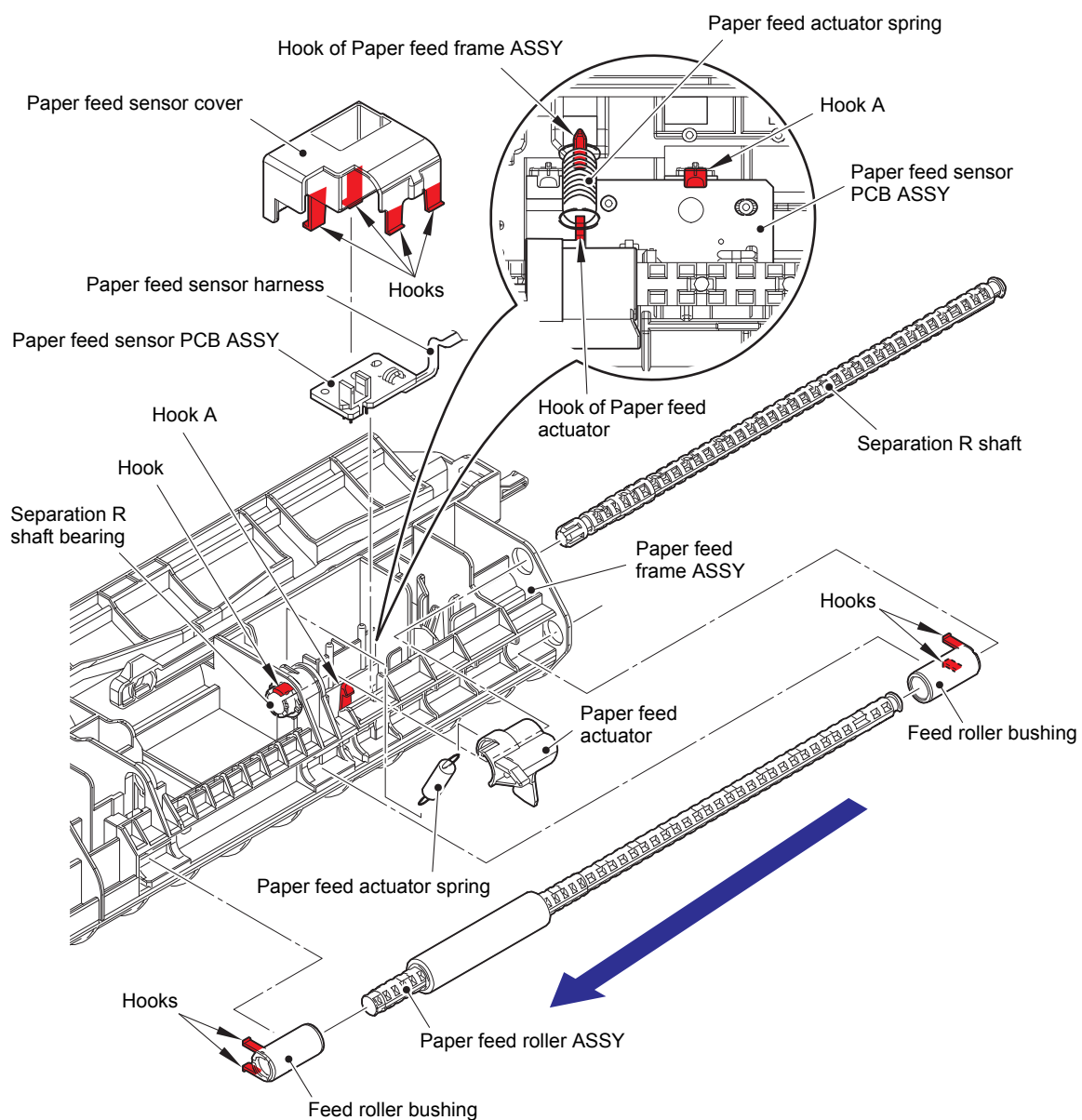


Fig. 3-104



---

# CHAPTER 4 ADJUSTING AND UPDATING SETTINGS AS REQUIRED AFTER PARTS REPLACEMENT

---

## 1. IF YOU REPLACE THE MAIN PCB ASSY

---

### ■ What to do after replacement

- Installing Firmware (Sub firmware and main firmware)
- Initializing the EEPROM of the Main PCB ASSY (Function code 01)
- Setting by Spec, Setting Serial Number and Entering Adjusted Value of Laser Unit
- Adjusting Touch Panel (Function code 61) (Touch panel models only)
- Acquiring White Level Data (Function code 55)

### ■ What you need to prepare

- (1) One USB cable
- (2) Create a temporary folder on the C drive of the computer (Windows® XP or later).
- (3) Service setting tool (SvSettingTool.exe)  
Copy this file into the temporary folder created on the C drive.  
\* .NET Framework 4.5.2 or later of Microsoft is needed to use SvSettingTool.
- (4) Download utility (FILEDG32.EXE)  
Copy this file into the temporary folder created on the C drive.
- (5) Maintenance printer driver (MaintenanceDriver.zip)  
When the maintenance printer driver is not installed on the computer, copy this file into the temporary folder created on the C drive, and extract the copied file. Refer to "APPENDIX 3 INSTALLING THE MAINTENANCE PRINTER DRIVER" for the installation procedure.
- (6) Firmware

Sub firmware	djf or upd file (ex. DXXXXX_A.djf or DXXXXX _A.upd)
Main firmware	djf or upd file (ex. DXXXXX_A.djf or DXXXXX _A.upd)

- (7) Touch pen (Touch panel models only)
- (8) Memory access tool (MemoryAccessTool.exe)

# 1.1 Installing Firmware (Sub firmware and main firmware)

## 1.1.1 Checking firmware version

Check whether the firmware installed on the machine is the latest version. If it is the latest version, there is no need to install the firmware. If it is not, be sure to install the firmware to the machine as described in “1.1.2 Installing firmware”.


### <How to check firmware version>

When the supply PCB is replaced with a new one, the machine automatically enters maintenance mode by turning it ON so the procedure below to enter the maintenance mode is not necessary.

#### For models without touch panel

- (1) Press the [Menu], and then the [Start] while the machine is in the ready state. Then, press the [▲] four times to enter the maintenance mode.
- (2) Press the [▲] or [▼] to display “MAINTENANCE 25” on the LCD, and press the [OK]. For keypad models, press the [2] and [5] in this order. The main firmware version information is displayed on the LCD.
- (3) Press the [Start] to display the version information of the sub firmware on the LCD, and then check the version information.

#### For models with touch panel

- (1) Press and hold the  for approximately five seconds while the machine is in the ready state.
- (2) Press the blank field at the bottom of the LCD.
- (3) Press the [\*], [2], [8], [6], and [4] on the LCD in this order to enter the maintenance mode.
- (4) Press the [2] and [5] in this order. The main firmware version information is displayed on the LCD.
- (5) Press the [Mono Start] to display the version information of the sub firmware on the LCD, and then check the version information.

#### **Note:**

- You can check the sub firmware and main firmware version by implementing “Print maintenance information (Function code 77)” (refer to “1.3.24 Print maintenance information (Function code 77)” in Chapter 5).

## 1.1.2 Installing firmware

### Note:

- Install the Sub firmware → Main firmware in this order.
- DO NOT disconnect the AC cord or USB cable from the machine or computer during installing.
- If the install is failed, turn OFF the machine and turn it back on. The machine enters the firmware installing mode automatically. Continue to the operating procedure below from the procedure (2).

### <Operating Procedure>

- (1) If the computer is connected to the machine using the USB cable, disconnect the USB cable to enter maintenance mode. (Refer to [“1.1 How to Enter Maintenance Mode” in Chapter 5](#)) When the supply PCB is replaced with a new one, the machine automatically enters maintenance mode by turning it ON so the procedure below to enter the maintenance mode is not necessary.
- (2) Connect the machine to your computer using the USB cable.
- (3) Open the temporary folder and double-click “FILEDG32.EXE” to start it, and select “Brother Maintenance USB Printer”.
- (4) Drag and drop the required program file (ex: LZXXXX\_\$.djf) in the same folder onto the Brother Maintenance USB Printer icon. The file is loaded to the machine, and installing to the flash ROM starts.
- (5) When installing is completed, the machine restarts and returns to the ready state automatically.
- (6) Turn OFF the power switch of the machine, and then repeat the procedures (1) to (5) to install required firmwares. However, when the supply PCB is replaced with a new one, the machine automatically enters maintenance mode by turning it ON so the procedure (1) to enter the maintenance mode is not necessary.
- (7) Turn OFF the power switch of the machine, and disconnect the USB cable.

## 1.2 Initializing the EEPROM of the Main PCB ASSY (Function code 01)

Initialize the EEPROM of the main PCB ASSY as described in [“1.3.1 Initialize EEPROM parameters \(Function code 01, 91\)” in Chapter 5](#).

# 1.3 Setting by Spec, Setting Serial Number and Entering Adjusted Value of Laser Unit


## <Operating Procedure>

(1) Follow the procedure below to enter the maintenance mode.

### Non-touch panel models

- 1) Press the [Menu] and then the [Start] while the machine is in the ready state. Then, press the [▲] four times to enter the maintenance mode.

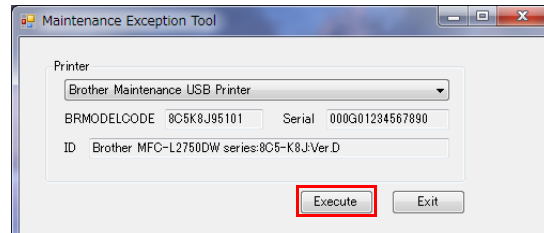
### Touch panel models

- 1) Press and hold the  for approximately five seconds while the machine is in the ready state until the screen changes.
- 2) Press the blank field at the bottom on the LCD.
- 3) Press the [\*], [2], [8], [6], and [4] in this order. The machine enters the maintenance mode.

(2) Connect the machine to your computer using the USB cable.

(3) Open the temporary folder and double-click "MemoryAccessTool.exe". The screen shown on the right appears.

(4) Click the [Execute] and close the Maintenance Exception Tool screen. Wait for 5 seconds or longer and then proceed to the next step.



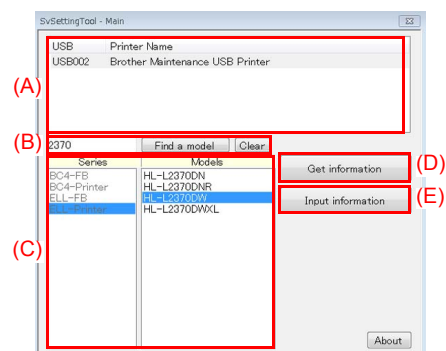
### Note:

- If the [Execute] on the Memory access tool is pressed once, it is valid as long as the machine does not quit the maintenance mode.
- If the BRMODELCODE, the Serial, and the ID fields are blank, quit the maintenance mode and then restart from step (1).

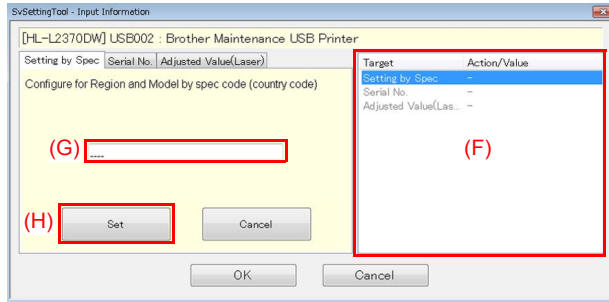
(5) Double-click "SvSettingTool.exe". The screen shown on the right appears.

(6) Check that the USB port connected with the machine is displayed in the box (A).

(7) Enter all or part of the model name in the box (B) and press the [Find a model]. Series name and model name are displayed in the box (C).



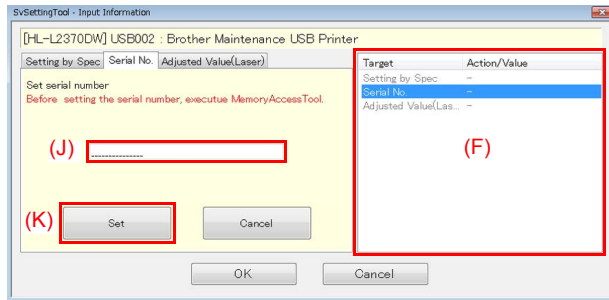
- (8) Click the [Input information] shown as (E).  
The Input Information screen shown on the right appears.



- (9) Click the [Setting by Spec] in the box (F). Set Spec Code screen appears.  
Enter the 4-digit country code in the box (G), and click the [Set] shown as (H).

“Set[\*\*\*\*]” and entered value appears on the “Setting by Spec” line in (F). (“\*\*\*\*” indicates the spec code entered.)

- (10) Click the [Serial No.] in the box (F). The Serial No. screen appears.



- (11) Enter the serial number (15 digits) of the machine in the box (J) and click the [Set] shown as (K).  
“Set[\*\*\*\*\*]” and entered value appears on the “Serial No.” line in the box (F). (“\*\*\*\*\*” indicates the Serial No. entered.)

- (12) Check the laser serial number label attached to the location shown in the illustration below.

Ex.) **SN011406058461734753**

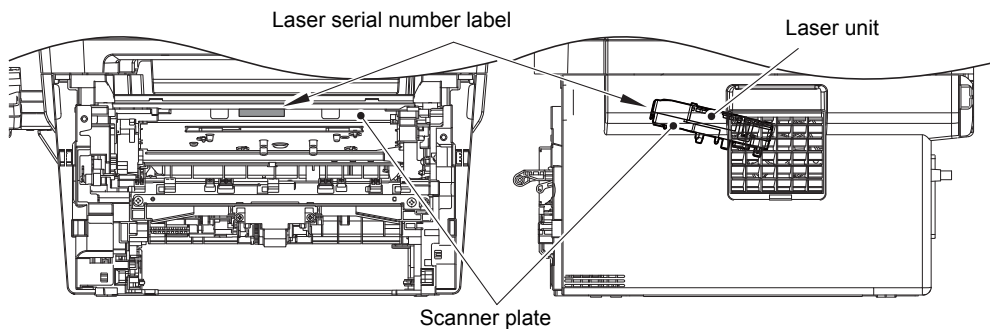
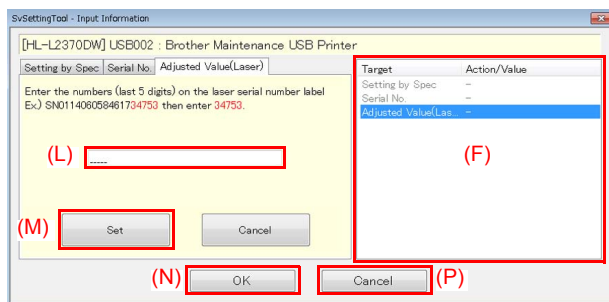


Fig. 4-1

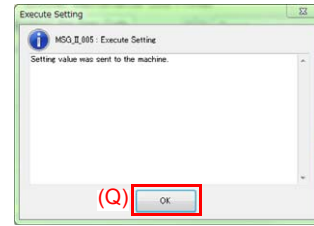
- (13) Click the [Adjusted Value(Laser)] in the box (F). The Laser Adjusted Value screen appears.



- (14) Enter the last five digits of the laser serial number in the box (L), and click the [Set] shown as (M). “Set[\*\*\*\*\*]” and entered value appears on the “Adjusted Value(Laser)” line in the box (F). (“\*\*\*\*\*” indicates the laser adjusted value entered.)

(15) Click the [OK] shown as (N).

The Execute Setting screen shown on the right appears and the setting by spec, setting serial number and entering adjusted value of laser unit is written to the machine.



(16) Click the [OK] shown as (Q) and close the Execute Setting screen.

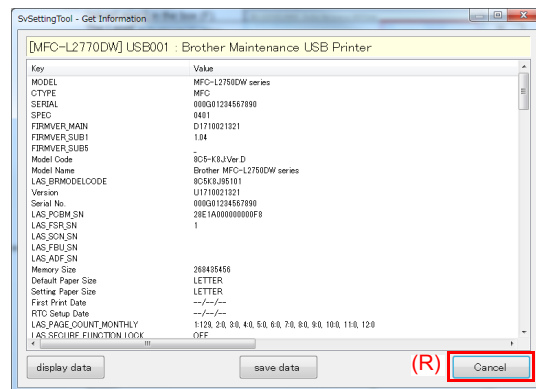
(17) Click the [Cancel] shown as (P) and close the Input Information screen.

(18) Click the [Get information] shown as (D).  
The machine maintenance information appears.

(19) In the maintenance information, check that the spec code in the “Spec” field, Serial No. in the “Serial No.” field and Laser Adjusted value in the “Laser Adjusted value(Position)” field.

(20) Click the [Cancel] shown as (R) and close the Get Information screen.

(21) Turn OFF the power switch of the machine and disconnect the USB cable from the machine and computer.



**Note:**

- The serial number can be set by referring to “1.3.27 Display machine log information (Function code 80)” in Chapter 5.
- For country code, refer to “1.3.23 Configure for country/region and model (Function code 74)” in Chapter 5. Please contact Brother distributors for the latest information.
- When the supply PCB is replaced with a new one, the machine automatically enters maintenance mode by turning it ON.
- Always turn the machine OFF and then ON again after setting the country. Turning the power switch OFF and then ON again starts the EEPROM formatting. Time required for formatting is 5 to 30 seconds depending on the product.

## 1.4 Adjusting Touch Panel (Function code 61) (Touch panel models only)

Adjust the touch panel as described in “1.3.18 Adjust touch panel (Function code 61)” in Chapter 5.

## 1.5 Acquiring White Level Data (Function code 55)

Acquire white level data as described in “1.3.16 Acquire white level data and set CIS scan area (Function code 55)” in Chapter 5.

## 2. IF YOU REPLACE THE LOW-VOLTAGE POWER SUPPLY PCB ASSY

---

### ■ What to do after replacement

- Reset Irregular Power Supply Detection Counter of the Low-voltage Power Supply PCB (Function code 88)

### ■ What you need to prepare

None

## 2.1 Reset Irregular Power Supply Detection Counter of the Low-voltage Power Supply PCB (Function code 88)

Refer to “1.3.30 Reset irregular power supply detection counter of low-voltage power supply PCB (Function code 88)” in Chapter 5 to reset the irregular power supply detection counter.

## 3. IF YOU REPLACE THE LASER UNIT

---

### ■ What to do after replacement

- [Entering Adjusted Value of Laser Unit](#)

### ■ What you need to prepare

- (1) One USB cable
- (2) Create a temporary folder on the C drive of the computer (Windows<sup>®</sup> XP or later).
- (3) Service setting tool (SvSettingTool.exe)  
Copy this file into the temporary folder created on the C drive.
- (4) Maintenance printer driver (MaintenanceDriver.zip)  
When the maintenance printer driver is not installed, copy this file into the temporary folder created on the C drive, and extract the copied file. Refer to [“APPENDIX 3 INSTALLING THE MAINTENANCE PRINTER DRIVER”](#) for the installation procedure.



### 3.1 Entering Adjusted Value of Laser Unit


#### <Operating Procedure>

(1) Follow the procedure below to enter the maintenance mode.

##### Non-touch panel models

1) Press the [Menu] and then the [Start] while the machine is in the ready state. Then, press the [▲] four times to enter the maintenance mode.

##### Touch panel models

1) Press and hold the  for approximately five seconds while the machine is in the ready state until the screen changes.  
 2) Press the blank field at the bottom on the LCD.  
 3) Press the [\*], [2], [8], [6], and [4] in this order. The machine enters the maintenance mode.

(2) Connect the machine to your computer using the USB cable.

(3) Open the temporary folder and double-click "SvSettingTool.exe". The screen shown on the right appears.

(4) Check that the USB port connected with the machine is displayed in the box (A).

(5) Enter all or part of the model name in the box (B) and press the [Find a model]. Series name and model name are displayed in the box (C).

(6) Check the laser serial number label attached to the location shown in the illustration below.

Ex.) **SN011406058461734753**

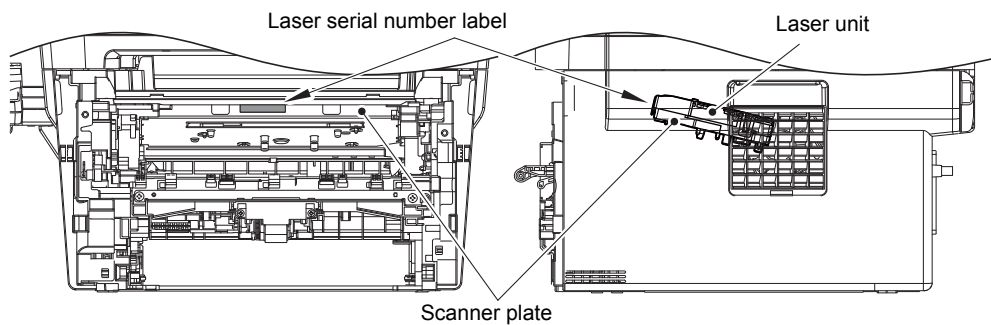
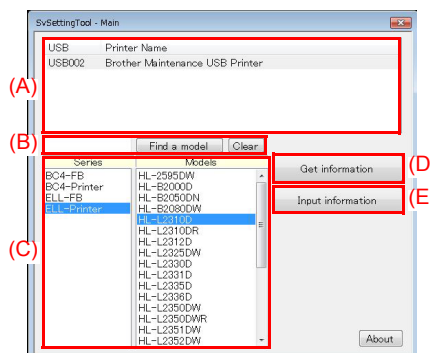
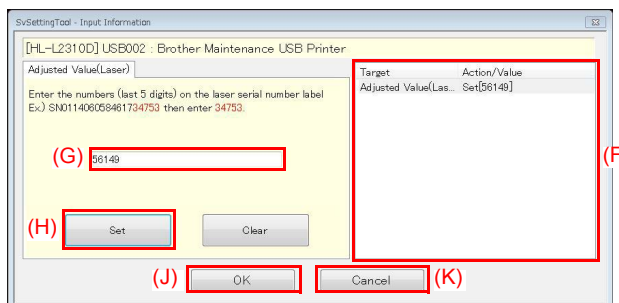


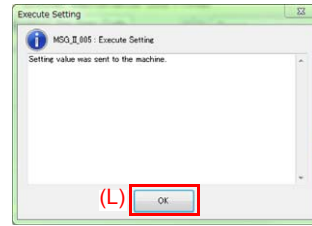
Fig. 4-2

(7) Click the [Adjusted Value(Laser)] in the box (F). The Laser Adjusted Value screen appears.

(8) Enter the last five digits of the laser serial number in the box (G), and click the [Set] shown as (H). "Set[\*\*\*\*\*]" and entered value appears on the "Adjusted Value(Laser)" line in the box (F). ("\*\*\*\*\*" indicates the laser adjusted value entered.)



- (9) Click the [OK] shown as (J).  
The Execute Setting screen shown on the right appears and the laser adjusted value is written to the machine.



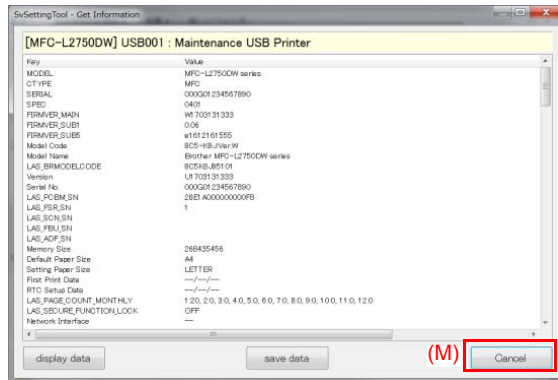
- (10) Click the [OK] shown as (L) and close the Execute Setting screen.
- (11) Click the [Cancel] shown as (K) and close the Input information screen.

- (12) Click the [Get information] shown as (D).  
The machine maintenance information appears.

- (13) In the maintenance information, check that the value in the “Laser Adjusted value(Video)” field, and the value in the “Laser Adjusted value(Position)” field are same as the value entered in procedure (8).

- (14) Click the [Cancel] shown as (M) and close the Get information screen.

- (15) Turn OFF the power switch of the machine and disconnect the USB cable from the machine and computer.



## 4. IF YOU REPLACE THE PANEL UNIT OR PANEL CONTROL PCB

---

### ■ What to do after replacement

- Adjusting Touch Panel (Function code 61) (Touch panel models only)
- Checking LCD Operation (Function code 12)

### ■ What you need to prepare (Touch panel models only)

- (1) Touch pen

## 4.1 Adjusting Touch Panel (Function code 61) (Touch panel models only)

Adjust the touch panel as described in “1.3.18 Adjust touch panel (Function code 61)” in Chapter 5.

## 4.2 Checking LCD Operation (Function code 12)

Check the LCD operation as described in “1.3.6 Check LCD operation (Function code 12)” in Chapter 5.

## 5. IF YOU REPLACE THE ADF UNIT, FIRST SIDE CIS UNIT, SECOND SIDE CIS UNIT OR DOCUMENT SCANNER UNIT

---

### ■ What to do after replacement

- [Acquiring White Level Data \(Function code 55\)](#)
- [Scanning and Printing Check](#)

### 5.1 Acquiring White Level Data (Function code 55)

Acquire white level data as described in "[1.3.16 Acquire white level data and set CIS scan area \(Function code 55\)](#)" in Chapter 5.

### 5.2 Scanning and Printing Check

Print a copy of any document with ADF, and check if there is any problem on the printed image.

Check if there is any problem on the ADF and the performance of recording part.

Check if there is any problem on the document scanner unit and the performance of recording part.

# CHAPTER 5 SERVICE FUNCTIONS

## 1. FUNCTION CODE


Maintenance mode is exclusively designed for checking, setting and adjusting the machine using the keys on the control panel. Using maintenance mode functions, you can conduct operational checks of sensors or test printing, display the log information or error codes, and change the worker switches (WSW) etc.

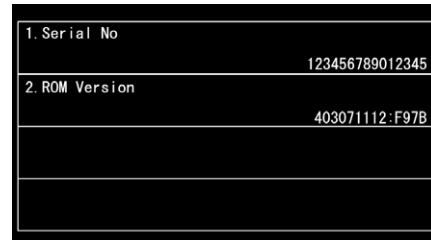
### 1.1 How to Enter Maintenance Mode

#### 1.1.1 Method of entering maintenance mode for service personnel

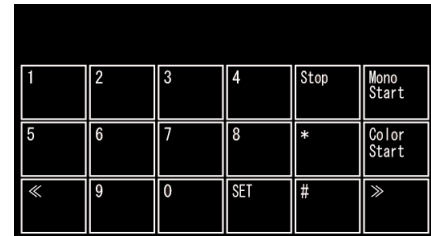
##### <Operating Procedure>

For models with touch panel

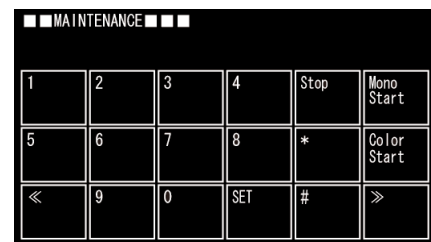
- (1) Press and hold the  for approximately five seconds while the machine is in the ready state. The display shown on the right appears on the LCD.



- (2) Press the blank field at the bottom. The display shown on the right appears on the LCD.



- (3) Press the [\*], [2], [8], [6], and [4] in this order. The display shown on the right appears on the LCD, and the machine enters into maintenance mode.
- (4) To select any of the maintenance mode functions shown in the ["1.2 List of Maintenance Mode Functions"](#), use the keypad to enter the maintenance mode function code to be executed.



For models without touch panel


- (1) Press the [Menu] and then the [Start] while the machine is in the ready state. Then, press the [▲] four times. "■■■MAINTENANCE■■■" appears on the LCD and the machine enters the maintenance mode.
- (2) To select any of the maintenance mode functions shown in the ["1.2 List of Maintenance Mode Functions"](#), use the keypad to enter the maintenance mode function code to be executed. For models without keypad, press the [▲] or [▼] to display any of the maintenance mode functions shown in the ["1.2 List of Maintenance Mode Functions"](#) on the LCD and select it by pressing the [OK].

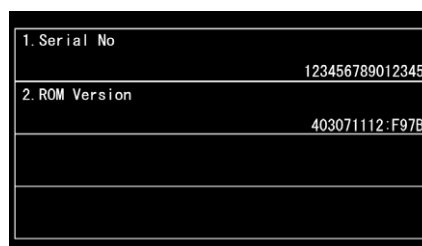
## 1.1.2 Method of entering end-user accessible maintenance mode

The maintenance mode functions should only be accessed by service personnel. However, end users are allowed to use some of these functions under the guidance of service personnel over the phone. End users can only use the functions shaded in the table “1.2 List of Maintenance Mode Functions” (Function code 09, 12, 25, 43, 45, 53, 54, 61, 77, 79, 80, 82, 87, 91).

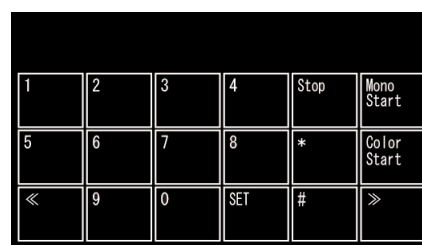
### <Operating Procedure>

#### For models with touch panel

- (1) Press and hold the  for approximately five seconds while the machine is in the ready state. The display shown on the right appears on the LCD.



- (2) Press the blank field at the bottom on the LCD. The display shown on the right appears on the LCD.
- (3) Press the [\*], [0], and [#] on the LCD in this order and “0” is displayed on the LCD. The machine enters into ready state to accept function code entry, so press the function code you want to execute.



- (4) Each time the selected maintenance mode function is completed, the machine returns to the ready state automatically.

#### For models without touch panel

- (1) Press the [Menu], [Start], and [Menu] in this order while the machine is in the ready state. “0” is displayed on the LCD.
- (2) To select any of the maintenance mode functions, use the keypad to enter the maintenance mode function code to be executed. For models without keypad, press the [▲] or [▼] to display any of the maintenance mode functions to be executed on the LCD and select it by pressing the [OK].
- (3) Each time the selected maintenance mode function is completed, the machine returns to the ready state automatically. However, for function codes 12, 25, 45, 80, and 82, pressing the [Stop/Exit] returns the machine to the ready state.

## 1.2 List of Maintenance Mode Functions

Function code	Function	Refer to:
01	Initialize EEPROM parameters	1.3.1 (5-4)
03	Transition to shipping state	1.3.2 (5-5)
08	ADF performance test	1.3.3 (5-6)
09	Print quality test pattern	1.3.4 (5-7)
10	Set worker switches (WSW)	1.3.5 (5-8)
11	Print worker switch (WSW) setting data	1.3.5 (5-8)
12	Check LCD operation	1.3.6 (5-11)
13	Check control panel key operation	1.3.7 (5-13)
25	Display software version	1.3.8 (5-15)
32	Check sensor operation	1.3.9 (5-16)
33	Display LAN connection status	1.3.10 (5-18)
43	Set PC print functions	1.3.11 (5-19)
45	Change USB No. return value / Adjust left-end print position / Adjust upper-end print position / Change ON/OFF setting for lower case compensation / Change ON/OFF setting for fixation strength improvement	1.3.12 (5-23)
46	Adjust printable range for each speed level	1.3.13 (5-27)
53	Transfer received fax data / log information (fax models only)	1.3.14 (5-29)
54	Fine-tune scanning position	1.3.15 (5-31)
55	Acquire white level data and set CIS scan area	1.3.16 (5-32)
57	Check toner cartridge	1.3.17 (5-33)
61	Adjust touch panel	1.3.18 (5-35)
67	Continuous print test	1.3.19 (5-36)
69	Print frame pattern (single-side printing)	1.3.20 (5-40)
70	Print frame pattern (duplex printing)	1.3.21 (5-41)
71	Test pattern	1.3.22 (5-42)
74	Configure for country / region and model	1.3.23 (5-45)
77	Print maintenance information	1.3.24 (5-52)
78	Check fan operation	1.3.25 (5-54)
79	Delete fax data	1.3.26 (5-54)
80	Display machine log information	1.3.27 (5-55)
82	Display machine error code	1.3.28 (5-57)
87	Send communication log information to telephone line	1.3.29 (5-58)
88	Reset irregular power supply detection counter of low-voltage power supply PCB	1.3.30 (5-58)
91	Initialize EEPROM parameters	1.3.1 (5-4)
99	Quit maintenance mode	1.3.31 (5-58)

\* The maintenance mode functions shaded in the table can be used by end users.

## 1.3 Details of Maintenance Mode Functions

### 1.3.1 Initialize EEPROM parameters (Function code 01, 91)

#### <Function>

This function is used to initialize the setting values for operation parameters, user switches, and worker switches (WSW) registered in the EEPROM. Entering function code 01 initializes most EEPROM areas. Entering function code 91 initializes only the specified areas as shown in the table below.

Data item	01	91	
Printer switch (Counter information)	Areas not to be initialized	Areas not to be initialized	
Error history			
Mac Address (Ethernet Address)			
Continuity counter			
Password for control panel operation lock	Areas to be initialized	Areas to be initialized	
Telephone function registration/ Telephone book			
Clock (RTC)			
Worker switches			
Secure function lock			
User switches (items initialized when Factory Reset is executed)			Areas to be initialized
Function settings except user switches (settings not subject to "Factory Reset")			
• Language			
• Interface			
LAN setting			
PCL core area (Emulation setting values)			

#### <Operating Procedure>

- (1) Press the [0], and then the [1] (or press the [9], and then the [1] as required) in the initial state of maintenance mode. For models without keypad, press the [▲] or [▼] to display "MAINTENANCE 01" (or "MAINTENANCE 91" as needed) on the LCD and press the [OK]. "PARAMETER INIT" is displayed on the LCD.
- (2) When initializing parameters is completed, the machine returns to the initial state of maintenance mode.

#### **Note:**

Function code 01 is for service personnel. Function code 91 is for user support.



### 1.3.2 Transition to shipping state (Function code 03)

The function code 03 includes following functions: Check sum information display for soft switch, Default special operation setting, and Resetting to factory shipping state. Check sum information display for soft switch is used by sales and production, not by servicemen.

Servicemen only use other two functions: Default special operation setting and Resetting to factory shipping state.

#### ■ Display soft switch check SUM

##### <Function>

This function is to display soft switch check SUM such as FSW/USW/WSW etc. Only for soft switch display and not used for the service.

This function is displayed on LCD after enter function code 03 as “1.SWSUM?”.

#### ■ Change ON/OFF setting of special function at start up

##### <Function>

By the special function at start up is set to an invalid state ([FUNC DISABLE]), “**■ Transfer to the shipping state**” in the next item can be used. Be careful it is unable to transfer the machine to the shipping state a valid state ([FUNC ENABLE]).

##### <Operating Procedure>

- (1) Press the [0], and then the [3] in the initial state of maintenance mode. For models without keypad, press the [▲] or [▼] to display “MAINTENANCE 03” on the LCD and press the [OK]. “1.SWSUM?” is displayed on the LCD.
- (2) Press the [▲] or [▼] to select “2.PowerOnFunc ?” and then press the [Start] or [Mono Start]. “FUNC ENABLE” or “FUNC DISABLE” is displayed on the LCD.
- (3) If “FUNC DISABLE” appears on the LCD, the machine's state is switchable to the factory shipping state. Press the [X] or [Stop] to return the machine to the initial state of maintenance mode.  
If “FUNC ENABLE” appears on the LCD, press the [▲] or [▼] to select “FUNC DISABLE”, and press the [SET] or [OK].  
The machine returns to the initial state of the function code 03.

## ■ Transfer to the shipping state

### <Function>

This function is to transfer the machine to the shipping state when used new spare main PCB for repair, etc. When not perform this function to the new spare main PCB and leave, some software will be unavailable such as MPS applications or BrAdmin tool. Also, the machine keeps poor state of security such as risk of leaking private information. Do not forget to perform this function after replacing the new spare main PCB. However, this product does not have function for place back to the pre-shipping state from the shipping state.

#### **Note:**

Be careful that if the special function at start up in the preceding item is a valid state ([FUNC ENABLE]), it is unable to transfer the machine to the shipping state. Be sure to operate after changing to an invalid state ([FUNC DISABLE]).

### <Operating Procedure>

- (1) Press the [0], and then the [3] in the initial state of maintenance mode. For models without keypad, press the [▲] or [▼] to display "MAINTENANCE 03" on the LCD and press the [OK]. "1.SWSUM?" is displayed on the LCD.
- (2) Press the [▲] or [▼] to select "3.ShippingStat?" and then press the [Start] or [Mono Start]. "ON" or "OFF: Change OK?" is displayed on the LCD.
- (3) When "ON" is displayed on the LCD, the machine is at shipping state. Press the [X] or [Stop] to return to the initial state of the maintenance mode.  
When "OFF: Change OK?" is displayed on the LCD, press the [SET] or [OK]. The machine will transfer to the shipping state and returns to the initial state of the maintenance mode.

## 1.3.3 ADF performance test (Function code 08)

### <Function>

This function is used to test the performance of the automatic document feeder (ADF). The scanned pages of the documents fed by the ADF are counted and the result is displayed on the LCD.

### <Operating Procedure>

- (1) Set the documents in the ADF unit. "DOC. READY" is displayed on the LCD.
- (2) Press the [0], and then the [8] in the initial state of maintenance mode. For models without keypad, press the [▲] or [▼] to display "MAINTENANCE 08" on the LCD and press the [OK]. "ADF CHECK P.\*\*" is displayed on the LCD, and the documents are ejected while the scanned pages are counted. (\*\* indicates the current count of the scanned pages.)
- (3) When the [X] or [Stop] is pressed, the machine returns to the initial state of maintenance mode.

### 1.3.4 Print quality test pattern (Function code 09)

#### <Function>

This function is used to print test patterns to check any missing image and print quality.

#### <Operating Procedure>

- (1) Press the [0], and then the [9] in the initial state of maintenance mode. For models without keypad, press the [▲] or [▼] to display "MAINTENANCE 09" on the LCD and press the [OK]. "PRINTING" is displayed on the LCD, and the machine starts printing the print quality test pattern (refer to the figure below).
- (2) When printing is completed, the machine returns to the initial state of maintenance mode.

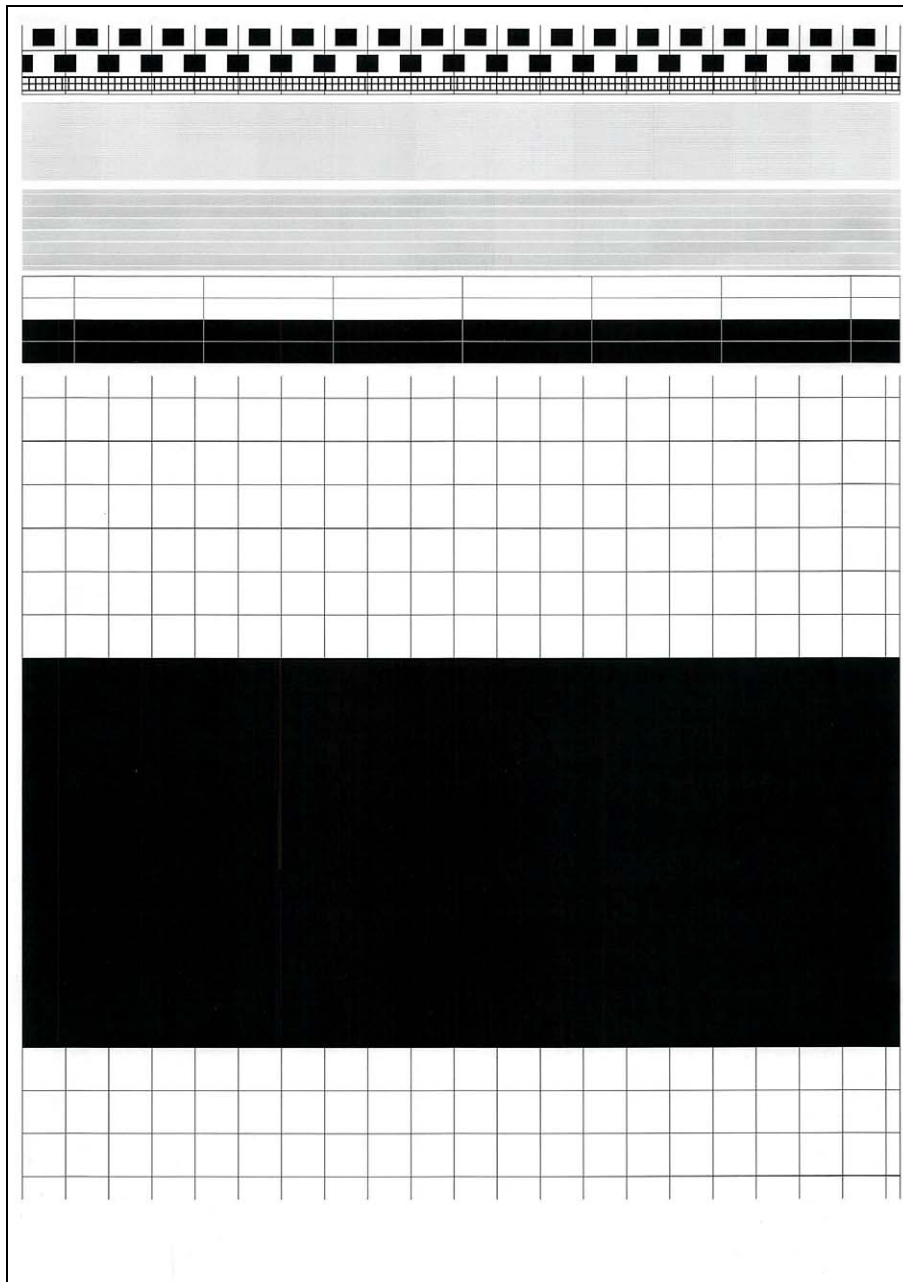


Fig. 5-1

### 1.3.5 Set worker switches (WSW) and print worker switch setting data (Function code 10, 11)

#### [1] Set worker switches (Function code 10)

##### <Function>

The worker switches shown in the table below can be used to set the function to satisfy various requirements. These switch settings can be changed using the keys on the control panel. The worker switches are factory set to conform to the laws and regulations of the country the machine is shipped to. Do not change these settings unless necessary.

WSW No.	Function	WSW No.	Function
WSW01	Dial pulse setting	WSW38	V.34 transmission settings
WSW02	Tone signal setting	WSW39	V.34 transmission speed
WSW03	PABX mode setting	WSW40	V.34 modem settings
WSW04	Transfer facility setting	WSW41	ON-duration of the scanning light source
WSW05	1st dial tone and busy tone detection		
WSW06	[Redial/Pause] and 2nd dial tone detection	WSW42	Internet mail settings
		WSW43	Function setting 16
WSW07	Dial tone setting 1	WSW44	Speeding up scanning-1
WSW08	Dial tone setting 2	WSW45	Speeding up scanning-2
WSW09	Protocol definition 1		
WSW10	Protocol definition 2	WSW46	PC power monitoring and parallel port settings
WSW11	Busy tone setting		
WSW12	Signal detection condition setting	WSW47	Switching between high- and full-speed USB
WSW13	Modem setting	WSW48	USB setup latency
WSW14	AUTO ANS facility setting	WSW49	End-of-copying beep
WSW15	Redial facility setting	WSW50	SDAA setting
WSW16	Function setting 1	WSW51	Function setting 17
WSW17	Function setting 2	WSW52	Function setting 18
WSW18	Function setting 3	WSW53	Function setting 19
WSW19	Transmission speed setting	WSW54	Function setting 20
WSW20	Overseas communication mode setting		
WSW21	TAD setting 1	WSW55	Interval for regular developing bias value correction
WSW22	ECM and call waiting caller ID	WSW56	Function setting 21
WSW23	Communication setting	WSW57	Function setting 22
WSW24	TAD setting 2	WSW58	Function setting 23
WSW25	TAD setting 3	WSW59	Function setting 24
WSW26	Function setting 4		
WSW27	Function setting 5	WSW60	Function setting 25
WSW28	Function setting 6		
WSW29	Function setting 7	WSW61	Scanning light intensity to judge to be stable 1
WSW30	Function setting 8	WSW62	Scanning light intensity to judge to be stable 2
WSW31	Function setting 9		
WSW32	Function setting 10	WSW63	Function setting 26
WSW33	Function setting 11	WSW64	Language / default paper size setting
WSW34	Function setting 12		
WSW35	Function setting 13	WSW65	Paper support setting
WSW36	Function setting 14	WSW66	Change of the setting is prohibited
WSW37	Function setting 15	WSW67	Change of the setting is prohibited
		WSW68	Change of the setting is prohibited
		WSW69	Change of the setting is prohibited
		WSW70	Change of the setting is prohibited

WSW No.	Function	WSW No.	Function
WSW71	Change of the setting is prohibited	WSW85	Function setting 29
WSW72	Change of the setting is prohibited	WSW86	Change of the setting is prohibited
WSW73	Change of the setting is prohibited	WSW87	Change of the setting is prohibited
WSW74	ADF stop control	WSW88	Detection of the threshold of remaining T1 amount
WSW75	Switch back ejection distance		
WSW76	Set the limit for the number of documents to be ejected in reverse order for single-side scanning from ADF	WSW89	Change of the setting is prohibited
		WSW90	Detection of the threshold of remaining T2 amount
		WSW91	Change of the setting is prohibited
WSW77	Set the limit for the number of documents to be ejected in reverse order for duplex scanning from ADF	WSW92	Change of the setting is prohibited
		WSW93	Detection of the threshold of remaining T3 amount
WSW78	Recording stop function when the drum reaches the end of life	WSW94	Detection of the threshold of remaining T4 amount
WSW79	Function setting 28	WSW95	Detection of the threshold of remaining T5 amount
WSW80	Copying speed control function		
WSW81	Changing emulation function enable/disable setting	WSW96	Change of the setting is prohibited
WSW82	AirPrint Icon No. setting	WSW97	Font type in Remote Setup display
WSW83	Change of the setting is prohibited	WSW98	Function setting 29
WSW84	Change of the setting is prohibited	WSW99	Change of the setting is prohibited

### <Operating Procedure>

- Press the [1], and then the [0] in the initial state of maintenance mode. For models without keypad, press the [▲] or [▼] to display "MAINTENANCE 10" on the LCD and press the [OK]. "WSW00" is displayed on the LCD.
- Enter the worker switch number that you want to change the setting. For models without keypad, press the [▲] or [▼] to display the worker switch number for which you want to change the setting on the LCD and press the [OK]. The following display appears on the LCD.

Selector No.1      Selector No.8  
                   ↓                   ↓  
 WSWXX = 0 0 0 0 0 0 0

- Press the [◀] or [▶] to move the cursor to the desired selector, and change the setting by pressing the [1] or [0]. For models without keypad, pressing the [▲] enters "1" and pressing the [▼] enters "0". Press either to enter desired number to Selector No.1. The next digit starts flashing. Keep entering numbers to Selector No.8 using the [▲] or [▼].
- When changing the setting is completed, press the [SET] or [OK]. The new selector setting value is stored in the EEPROM, and the LCD returns to the ready state for worker switch number entry ("WSW00").
- When all switch setting is completed, press the [X] or [Stop] to return the machine to the initial state of maintenance mode.

#### Note:

- To cancel operation and return to the initial state of maintenance mode, press the [X] or [Stop].
- If there is no entry for one minute or longer on 2-digit worker switch number selection after the first digit was entered, the machine returns to the initial state of maintenance mode automatically.

## [2] Print worker switch (WSW) setting data (Function code 11)

### <Function>

This function is used to print the worker switch settings and details.

### <Operating Procedure>

- (1) Press the [1] twice in the initial state of maintenance mode. For models without keypad, press the [▲] or [▼] to display "MAINTENANCE 11" on the LCD and press the [OK].
- (2) "PRINTING" is displayed on the LCD, and printing the CONFIGURATION LIST (refer to the figure below) starts.
- (3) When printing is completed, the machine returns to the initial state of maintenance mode.

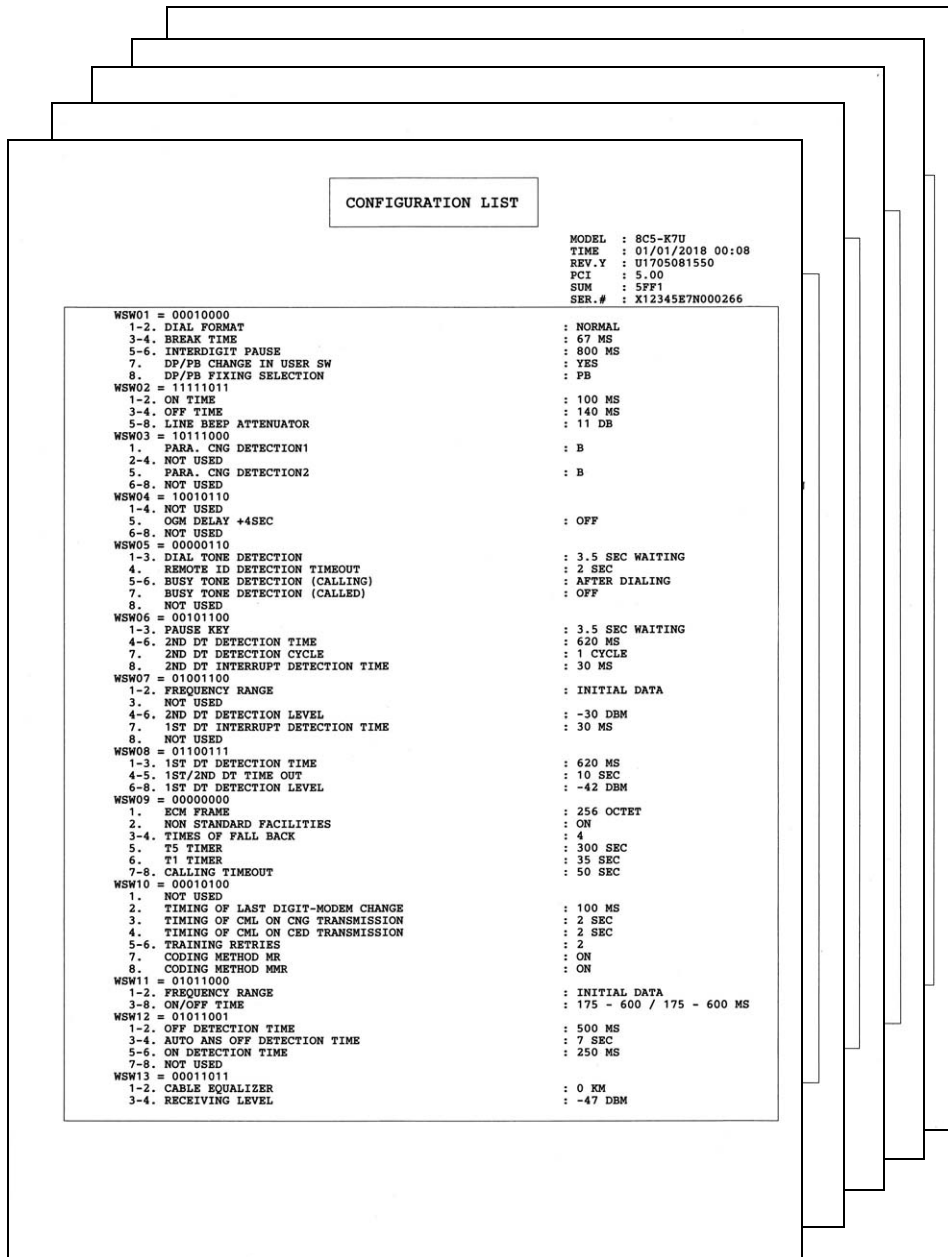


Fig. 5-2





### 1.3.6 Check LCD operation (Function code 12)

#### <Function>


This function is used to check that the LCD on the control panel is operating normally.

#### <Operating Procedure>

For models with touch panel

- (1) Press the [1], and then the [2] in the initial state of maintenance mode. LCD displays shown as the chart below.
- (2) Press the  to switch the display column A and display column B. By pressing the , LCD moves to the next display of the each column according to the chart. When you press the  at the Display B-7, LCD returns to display B-1. Press the  to return to the last LCD display.

#### Note:

At <Display A-7>, you cannot switch the display to column B even press the .

- (3) When you press the [X] at the Display A-7 or B-1 to 7, the machine returns to the initial state of the maintenance mode.


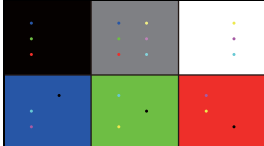
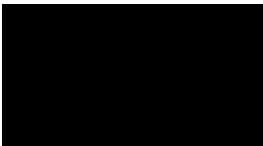






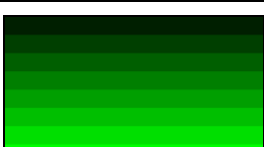

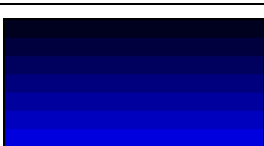
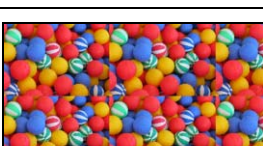
<p>&lt;Display A-1&gt; all white</p> 	<p>&lt;Display B-1&gt; bright point/ down point</p> 
<p>&lt;Display A-2&gt; all black</p> 	<p>&lt;Display B-2&gt; bright point</p> 
<p>&lt;Display A-3&gt; all gray</p> 	<p>&lt;Display B-3&gt; white gradual</p> 
<p>&lt;Display A-4&gt; all red</p> 	<p>&lt;Display B-4&gt; red gradual</p> 
<p>&lt;Display A-5&gt; all green</p> 	<p>&lt;Display B-5&gt; green gradual</p> 
<p>&lt;Display A-6&gt; all blue</p> 	<p>&lt;Display B-6&gt; blue gradual</p> 
<p>&lt;Display A-7&gt; picture data</p> 	<p>&lt;Display B-7&gt; Displays BMP file in the Media by rotation</p>

Fig. 5-3

For models without touch panel

- (1) Press the [1], and then the [2] in the initial state of maintenance mode. For models without keypad, press the [▲] or [▼] to display “MAINTENANCE 12” on the LCD and press the [OK]. Displays shown in the figure below appear on the LCD.
- (2) Each press of the [Start] cycles through the displays as shown in the figure below.
- (3) Press the [Stop], and the machine returns to the initial state of maintenance mode.

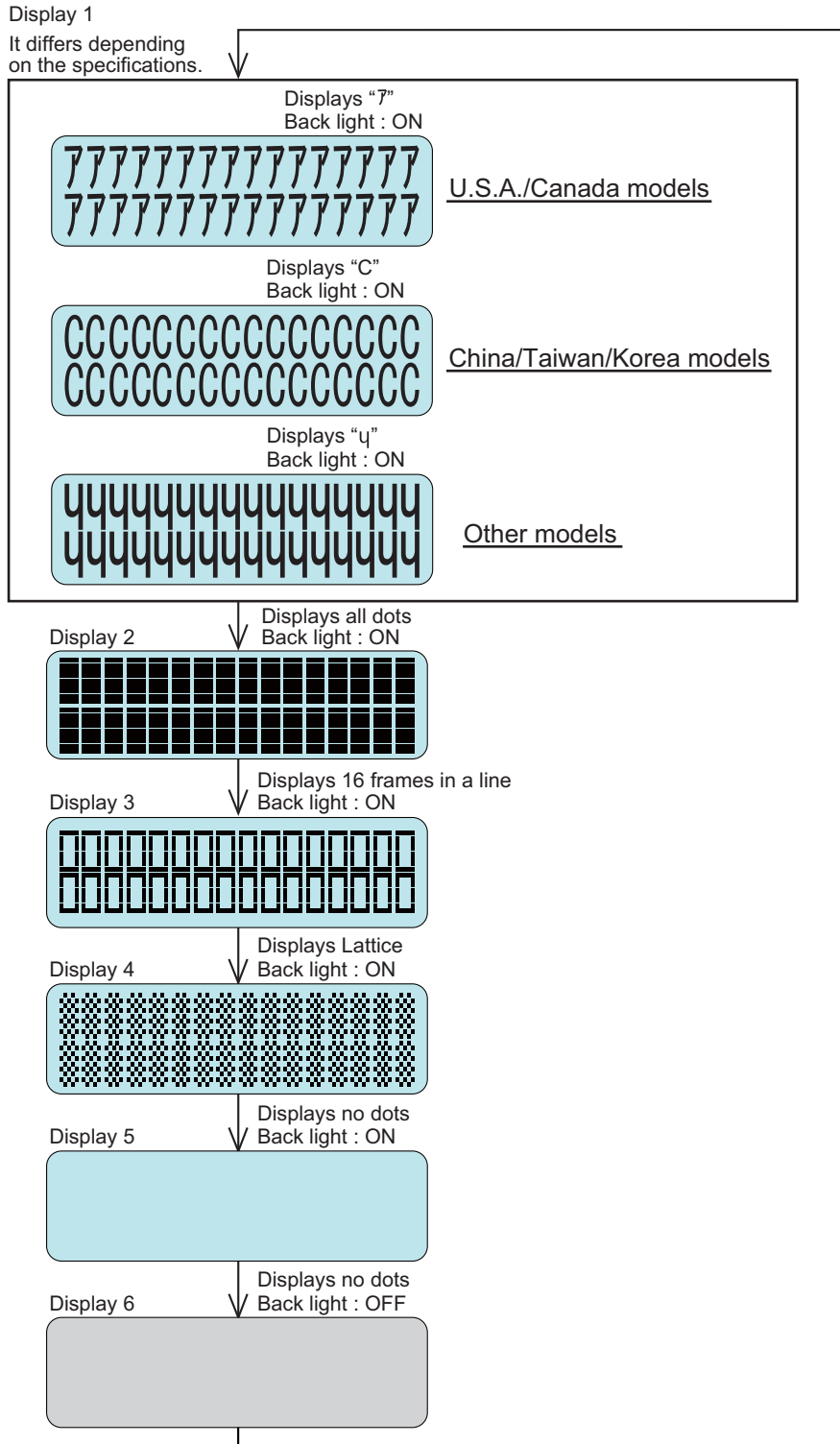


Fig. 5-4



### 1.3.7 Check control panel key operation (Function code 13)

#### <Function>

This function is used to check that keys on the control panel are operating normally.

#### <Operating Procedure>

- (1) Press the [1], and then the [3] in the initial state of maintenance mode. For models without keypad, press the [▲] or [▼] to display “MAINTENANCE 13” on the LCD and press the [OK]. “00” is displayed on the LCD.
- (2) Press the keys on the control panel according to the numbers provided in the figure below. Each time the key is pressed, the corresponding figure is displayed on the LCD in decimal notation. Check that the number displayed on the LCD matches the number assigned to the key that has been pressed. If the keys are pressed in the incorrect order, “INVALID OPERATE” is displayed on the LCD. Press the [X] or [Stop] and try again with the correct key.
- (3) When the key operation is normal, the machine returns to the initial state of maintenance mode when the last key is pressed. To cancel operation and return to the initial state of maintenance mode, press the [X] or [Stop].

#### ■ Order of pressing keys

DCP-L2510D/L2510DR/L2511D/L2535D/L2536D/B7500D(Except CHN)/L2531DW/  
DCP-L2532DW/L2535DW/L2537DW/L2550DN/L2550DNR/L2250DW/L2551DW/L2552DN,  
HL-L2390DW



Fig. 5-5

DCP-7090/7095D/7190DN/7195DW/B7500D(CHN)/B7530DN



Fig. 5-6

MFC-L2690DW/L2710DN/L2710DNR/L2710DW/L2710DWR/L2712DN/L2712DW/  
MFC-L2713DW/L2715D/L2715DW/L2716D/L2716DW/L2717DW/B7715DW

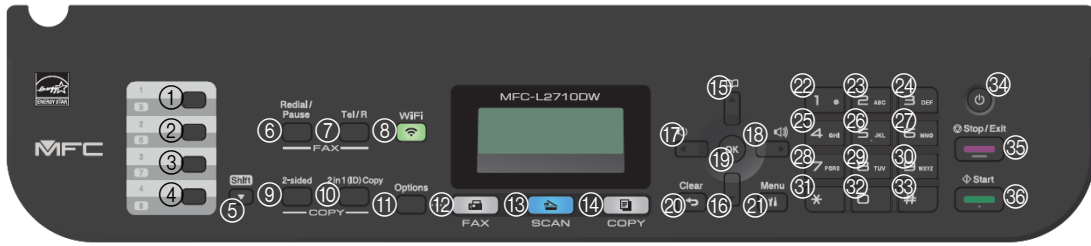


Fig. 5-7

MFC-7390/7490D/B7700D/B7720DN/7890DN



Fig. 5-8

MFC-L2730DW/L2730DWR/L2732DW/L2750DW/L2750DWR/L2751DW/L2770DW/  
MFC-L2771DW/7895DW,  
HL-L2395DW



Fig. 5-9

### 1.3.8 Display software version (Function code 25)

#### <Function>

This function is used to check the version information of the firmwares and programs, or check sum information.

#### <Operating Procedure>

- (1) Press the [2], and then the [5] in the initial state of maintenance mode. For models without keypad, press the [▲] or [▼] to display "MAINTENANCE 25" on the LCD and press the [OK]. "MAIN:Ver\*.\*\*(#)" is displayed on the LCD.
- (2) Pressing the [Start] or [Mono Start] changes the display to the next item.
- (3) Press the [X] or [Stop], and the machine returns to the initial state of maintenance mode.

LCD	Description
TOTAL: Ver1.00 (A) <sup>*1</sup>	Main firmware version information
SUB1 : Ver1.00 (P) <sup>*1</sup>	Sub firmware version information ((P): Identifier for PCL/PS) <sup>*2</sup>
ENG : Ver1.00	Engine program version information
NET : Ver1.00	Network program version information
SUB5 :1.00(1.00a) <sup>*1</sup>	Sub 5 firmware version information
i0801170900:0000	I-FAX version information
B1612312359:1234 <sup>*1</sup>	Boot program creation date and check sum information
U1612312359:1234 <sup>*1</sup>	Main firmware creation date and check sum information
P0612271602:BD40 <sup>*1</sup>	Sub firmware (PCL/PS) creation date and check sum information
e0612312359:1234	Sub 5 firmware creation date and check sum information <sup>*3</sup>
ROM Check Sum	Check sum self-diagnosis function <sup>*4</sup>

<sup>\*1</sup> How to display the check sum information  
You can check the check sum information by pressing the [SET] or [OK] while each version is displayed. When the [SET] or [OK] is pressed again, the LCD returns to the version display.

<sup>\*2</sup> (P), (G), or (-) is displayed at the place of (P).  
(P): Supports PCL/PS, (G): Supports GDI, (-): Unrecognized

<sup>\*3</sup> Displayed only on TP models to particular destination.

<sup>\*4</sup> There are two types of check sum information that can be checked with this function. This function checks if the two types of check sum information match each other. When the [SET] or [OK] is pressed while "ROM Check Sum" is displayed, check is automatically conducted for each ROM of each software part. When the check sum matches, "OK" is displayed on the LCD. When all ROMs result in "OK", "ROM Check Sum OK" is displayed at the end, and the operation is finished. When the check sum of any ROM does not match, "NG" is displayed, and the display stops.

### 1.3.9 Check sensor operation (Function code 32)

#### <Function>

This function is used to check whether the sensors, solenoids, and clutches are operating normally.

#### <Operating Procedure>

- (1) Press the [3], and then the [2] in the initial state of maintenance mode. For models without keypad, press the [▲] or [▼] to display "MAINTENANCE 32" on the LCD and press the [OK]. Following example is displayed on the LCD.  
e.g.) CVRCPONT\*\*\*\*\*  
Buzzing sound comes out continuously from models with speaker.  
Information related to the toner box is not displayed on the LCD when those are not connected.
- (2) Pressing the [Start] or [Mono Start] changes the display to the next item.
- (3) Change the conditions subject to sensor detection shown below and check that the display on the LCD changes depending on the sensor status. For example, feed the paper through the registration front/rear sensor, open the front cover or back cover, remove the toner cartridge, or create paper jam at the exit.
- (4) Press the [X] or [Stop], and the machine returns to the initial state of maintenance mode.

#### Note:

Press the [SET] or [OK] to stop the buzzing sound from the speaker.

#### <Sensor check>

The table below summarizes the displays on the LCD, sensor names and detection status.

LCD	Sensor name	Detection status	
		With display	No display
CV	Front cover sensor	Front cover closed	Front cover open
RC	Back cover/duplex tray sensor	Back cover closed and Duplex tray set	Back cover open and No duplex tray
PO	Eject sensor	No paper	Paper set
NT <sup>*1</sup>	New toner/Toner cartridge detect sensor	OFF/ Toner cartridge set	ON/ No toner cartridge
NP <sup>*2</sup>	New process cartridge/process cartridge detect sensor	OFF/ Process cartridge set	ON/ No process cartridge
NB <sup>*2</sup>	New toner box/Toner box cartridge detect sensor	OFF/ Toner box cartridge set	ON/ No toner box cartridge
NT <sup>*2</sup>	Toner amount sensor	Toner not full	Toner full
C1	Paper feed sensor	T1 closed and No paper	T1 open and Paper set
RM	Registration front sensor	No paper	Paper set
RA	Registration rear sensor	No paper	Paper set
MP	MP paper empty sensor	No paper	Paper set
P1	Paper empty sensor	No paper	Paper set
DF	Document detection sensor	No document	Document set
DR	Document scanning position sensor	No document	Document set
AC	ADF cover sensor	ADF cover closed	ADF cover open
HK <sup>*3</sup>	Hook switch	On hook	Off hook

<sup>\*1</sup> Available on models without toner box    <sup>\*2</sup> Available on models with toner box

<sup>\*3</sup> Available on models with handset

■ Location of sensors

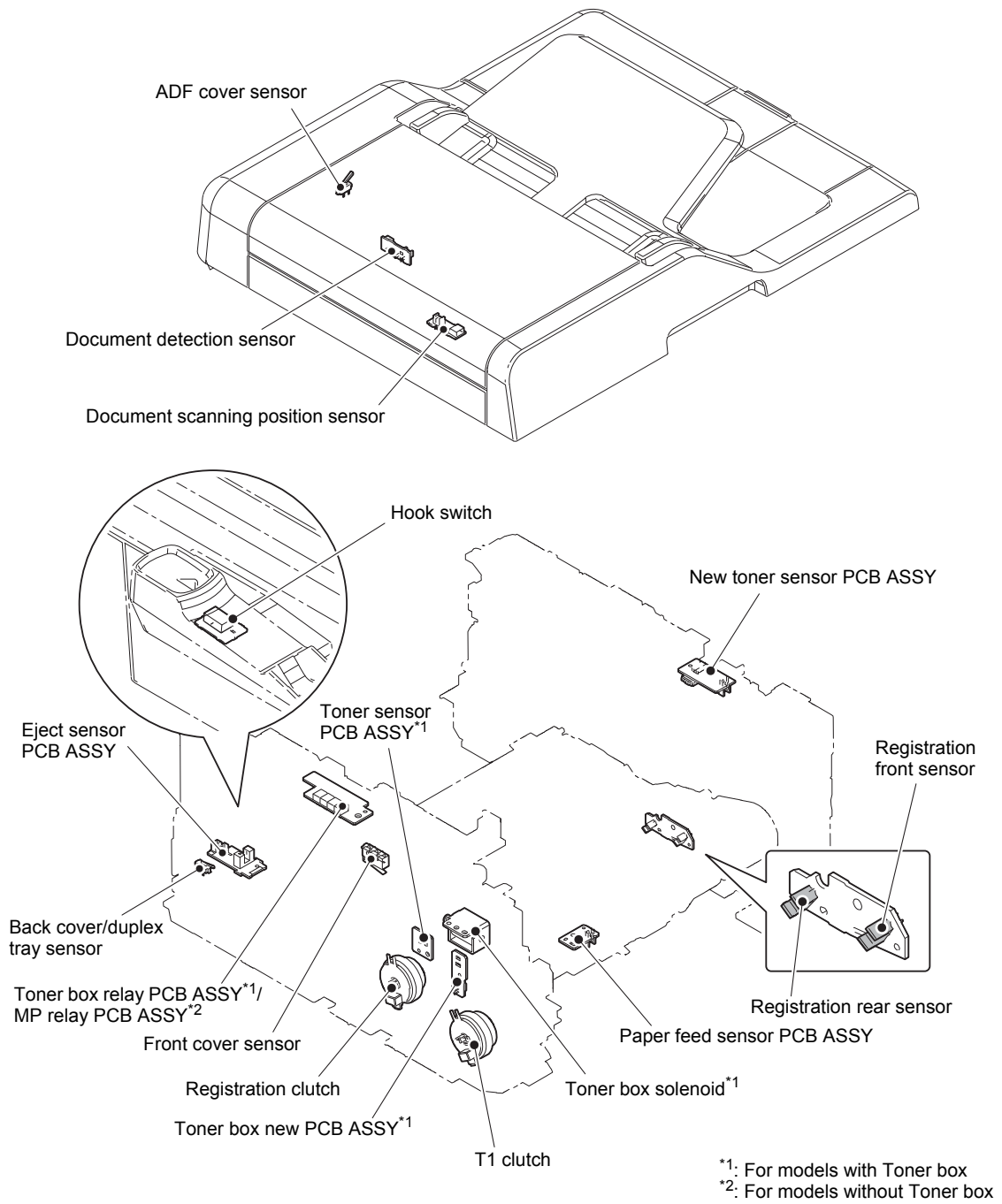


Fig. 5-10

### 1.3.10 Display LAN connection status (Function code 33)

#### <Function>

This function is used to check the connection status of the wired LAN.

#### <Operating Procedure>

- (1) Press the [3] twice in the initial state of maintenance mode. For models without keypad, press the [▲] or [▼] to display "MAINTENANCE 33" on the LCD and press the [OK].
- (2) One of the items in the following table is displayed on the LCD depending on the wired LAN connection of the machine.
- (3) Press the [X] or [Stop], and the machine returns to the initial state of maintenance mode.

LCD	LAN connection status
Active 100B-FD	100B-FD
Active 100B-HD	100B-HD
Active 10B-FD	10B-FD
Active 10B-HD	10B-HD
Inactive	Not connected

### 1.3.11 Set PC print functions (Function code 43)

#### <Function>

This function is used to change the settings of the various print functions summarized in the table below.

#### <Operating Procedure>

- (1) Press the [4], and then the [3] in the initial state of maintenance mode. For models without keypad, press the [▲] or [▼] to display "MAINTENANCE 43" on the LCD and press the [OK]. "Manual Feed" is displayed on the LCD.
- (2) Press the [▲] or [▼] to display the function you want to change the setting of, and press the [SET] or [OK].
- (3) For fixed parameters (On/Off, etc.), press the [▲] or [▼] to display the setting you want to apply, and press the [SET] or [OK].  
For parameters requiring numerical value entry, use the keypad to enter a numerical value if the model has it, and press the [SET].  
For models without keypad, press the [▲] or [▼] to change the selected number (0 to 9).
- (4) When the [X] or [Stop] is pressed, the machine returns to the initial state of maintenance mode.

#### ■ Setting functions

The available functions change depending on the corresponding emulation.  
(For the emulation specifications, refer to "1. GENERAL" in Chapter 1.)

<For models with emulation>

LCD	Description	Set value	Default
Common functions			
Manual Feed	Manual feed setting	On/Off	Off
Resolution	Print resolution	300/600/1,200 dpi	600 dpi
Toner Save	Toner save mode setting	On/Off	Off
Density	Print density level	-6 to 6	0
Job Cancel TimeOut	Time until host timeout after a job is canceled	0 to 255 seconds	4 seconds
Sleep Time	Time until engine sleep mode is entered	0 to 99 minutes	5 minutes
Page Protection	Page memory setting	Off/LTR/A4/LGL/Auto	Off
Emulation	Emulation (print language) setting	Auto/HP/PS	Auto
Auto I/F Time	Interface open time setting	1 to 99 seconds	5 seconds
Media Type	Paper type setting	Thin/Plain/Thick/Thicker/Transparency/Recycled/Bond/Envelopes/EnvThin/EnvThick	Plain or Thin
Paper Size	Image development area setting	Letter/Legal/A4/Exec/B5/JISB5/A5/B6/A6/Monarch/C5/COM10/DL/DLL/A4Long/Hagaki/Folio	Letter or A4
Copies	Number of copies	1 to 99 copies	1 copy

LCD	Description	Set value	Default
Orientation	Print direction setting	Portrait/Landscape	Portrait
P-Pos X-Offset	Print position offset in X (landscape) direction	-500 to 500 (1/300 dpi)	0 (1/300 dpi)
P-Pos Y-Offset	Print position offset in Y (portrait) direction	-500 to 500 (1/300 dpi)	0 (1/300 dpi)
Auto FF	Auto Form Feed setting	On/Off	Off
Auto FF Time	Time until Auto Form Feed timeout	1 to 99 seconds	5 seconds
FF Suppress	Blank page skip setting	On/Off	Off
Additional functions - For models with PCL6			
Auto LF	Auto linefeed (LF) setting	On/Off	Off
Auto CR	Auto carriage return (CR) setting	On/Off	Off
Auto WRAP	Auto CRLF by print width	On/Off	Off
Auto Skip	Back end / tip skip setting	On/Off	On
Left Margin	Left margin setting	0 to 145 columns	0 column
Right Margin	Right margin setting	10 to 155 columns	80 columns
Top Margin	Top margin setting	0 to 2.00 inches	0.5 inches
Bottom Margin	Bottom margin setting	0 to 2.00 inches	0.5 inches
Lines	Text lines per page	5 to 128 lines	60 lines
Additional functions - For models with BR-Script3			
Error Print	Error Print setting in the event of PostScript error	On/Off	On

<For models without emulation>

LCD	Description	Set value	Default
Manual Feed	Manual feed setting	On/Off	Off
Job Cancel TimeOut	Time until host timeout after a job is canceled	0 to 255 seconds	4 seconds
Sleep Time	Time until engine sleep mode is entered	0 to 99 minutes	5 minutes
Auto I/F Time	Interface open time setting	1 to 99 seconds	5 seconds
P-Pos X-Offset	Print position offset in X (landscape) direction	-500 to 500 (1/300 dpi)	0 (1/300 dpi)
P-Pos Y-Offset	Print position offset in Y (portrait) direction	-500 to 500 (1/300 dpi)	0 (1/300 dpi)



■ **Detail description**

LCD	Detail description
Manual Feed	Valid for printing from the computer, and for printing NetWorkConfig, TestPrint, Fontlist, or Configuration from the panel. When the tray is selected on the computer, the setting on the computer supersedes the setting on the LCD.
Resolution	Valid for printing from the computer only. When the resolution is set on the computer, the setting on the computer supersedes the setting on the LCD.
Toner Save	Valid for all types of printing except copy, and the Function Menu setting will also be changed. When the TonerSave is set on the computer, the setting on the computer supersedes the setting on the LCD.
Density	Valid for printing from the computer, and for printing NetWorkConfig, TestPrint, Fontlist, or Configuration from the panel. Linked with the Toner Save setting, and the density is determined based on both settings. When the Density is set on the computer, the setting on the computer supersedes the setting on the LCD.
Job Cancel TimeOut	Sets the time until the host timeout after a job is canceled. The setting unit is on the second time scale.
Sleep Time	Sets the time until the sleep mode is entered. The Function Menu setting will also be changed.
Page Protection	Sets the page memory to be secured for data processing before printing in the computer. As this is a setting in the PCL-Core, this does not affect the memory management of the machine.
Emulation	Changes the print language. The Function Menu setting becomes valid. For data with ENTERLANGUAGE, this setting supersedes the setting on the LCD.
Auto I/F Time	Change the interface open time. This setting becomes valid when PC print is instructed, and becomes invalid when PC-Scan or Remote-SetUp is instructed.
Media Type	Valid for printing from the computer only. When the Paper type is set on the computer, the setting on the computer supersedes the setting on the LCD. The default varies depending on the country setting. "Thin" is the default for China and "Plain" is the default for other countries.
Paper Size	Changes the image development area. Sets the drawing size for PC-Print, instead of the setting for Paper Size in the menu. When the Paper size is set on the computer, the setting on the computer supersedes the setting on the LCD. The default varies depending on the country setting. "Letter" is the default for U.S.A. / Canada and "A4" is the default for other countries.
Copies	Valid for printing from the computer only. When the number of copies is set on the computer, the setting on the computer supersedes the setting on the LCD.
Orientation	Changes the printing direction. Valid for printing from the computer only.
P-Pos X-Offset	Sets the print position offset in the X (landscape) direction. Valid for printing from the computer only. When the X-Offset is set on the computer, the setting on the computer supersedes the setting on the LCD.

LCD	Detail description
P-Pos Y-Offset	Sets the print position offset in the Y (portrait) direction. Valid for printing from the computer only. When the Y-Offset is set on the computer, the setting on the computer supersedes the setting on the LCD.
Auto FF	Sets ON or OFF for AutoFF (automatic form feed). Valid for printing from the computer only.
Auto FF Time	Sets the time until timeout after AutoFF is set to ON.
FF Suppress	Sets whether to skip blank pages. Valid for printing from the computer only. On or Off setting of the blank data for copying or faxing cannot be changed in this setting.
Auto LF	Sets the auto linefeed.
Auto CR	Sets the auto carriage return. Adds CR to the LF code.
Auto WRAP	Sets the auto CRLF by the print width.
Auto Skip	Sets whether to skip at the back end / tip of paper. Adds a blank space.
Left Margin	Sets the column space at the left side.
Right Margin	Set the column space at the right side.
Top Margin	Sets the space at the top.
Bottom Margin	Sets the space at the bottom.
Lines	Sets the number of lines in the PCL.
Error Print	Sets the Error Print in the event of a BR-Script3 error.

### 1.3.12 Change USB No. return value / Adjust left-end print position / Adjust upper-end print position / Change ON/OFF setting for lower case compensation / Change ON/OFF setting for fixation strength improvement (Function code 45)

#### ■ Change USB No. return value

##### <Function>

When the operating system (OS) installed on the computer is Windows Vista®, and the machine is connected to this computer using USB2.0FULL, the OS may not be able to obtain the USB device serial number depending on the computer and USB device. If the serial number cannot be obtained, the number of devices increases each time the device is connected to the computer. To avoid this problem, set this function to “USBNo.=ON” and fix the USB No. return value to “0”.

LCD	Description
USBNo. =ON	Returns the serial number of the machine. (default)
USBNo. =OFF	Returns “0”.

The setting currently selected is marked “\*” at the end of the display.

##### <Operating Procedure>

- (1) Press the [4], and then the [5] in the initial state of maintenance mode. For models without keypad, press the [▲] or [▼] to display “MAINTENANCE 45” on the LCD and press the [OK]. “USBNo.” is displayed on the LCD.
- (2) Press the [SET] or [OK]. “USBNo.=OFF” is displayed on the LCD.
- (3) Press the [▲] or [▼] to select “USBNo.=ON” or “USBNo.=OFF”, and then press the [SET] or [OK].
- (4) “Accepted” is displayed on the LCD, and the machine returns to the initial state of maintenance mode.
- (5) Turn the power switch OFF.

##### **Note:**

This setting is applied after the power switch is turned OFF and then ON again.

## ■ Adjust left-end print position

### <Function>

In the event that the left-end print start position deviates, use this function to adjust the position left and right. The adjustable range is -100 to 750 (1 unit = 0.084 mm = 300 dpi).

(Shifted to the left when the value is negative)

### <Operating Procedure>

- (1) Press the [4], and then the [5] in the initial state of maintenance mode. For models without keypad, press the [▲] or [▼] to display "MAINTENANCE 45" on the LCD and press the [OK]. "USBNo." is displayed on the LCD.
- (2) Press the [▲] or [▼] to display "X Adjust" on the LCD, and press the [SET] or [OK]. "XAdjust MP" is displayed on the LCD.
- (3) Refer to <Adjustment option table> in the table below, press the [▲] or [▼] to select from the adjustment options, and press the [SET] or [OK]. "XAdj. \*\*= 0\*\*" is displayed on the LCD. (Selected option is shown for \*\*.)
- (4) To shift the writing start position to the left, press the [▼] to decrease the value. To shift the position to the right, press the [▲] to increase the value.
- (5) Press the [SET] or [OK] after adjusting the value. "Accepted" is displayed on the LCD.
- (6) Press the [X] or [Stop], and the machine returns to the initial state of maintenance mode.

### <Adjustment option table>

#### Single-side printing

Adjustment option	LCD
MP tray first side	X Adjust MP
Paper tray first side	X Adjust T1
N/A (disabled)	X Adjust DX
N/A (disabled)	X Adjust DXMP

#### Duplex printing

Adjustment option	LCD
MP tray second side	X Adjust MP
Paper tray second side	X Adjust T1
*1	X Adjust DX
MP tray first side	X Adjust DXMP
Paper tray first side	X Adjust DXT1

- \*1 Adjusts first side print start position of all tray (paper tray and MP tray). Value of X Adjust DX is added to each tray adjustment value.  
For example, when printing from paper tray, it adjusts as "X Adjust DXT1 value" + "X Adjust DX value" and print. Besides, when the added value is over than the adjustable range (-100 to 750), adjusted value will be for minimum -100 and maximum 750 and does not become out of adjustable range.

## ■ Adjust upper-end print position

### <Function>

In the event that the upper-end print start position deviates, use this function to adjust the position up and down. Adjustable range is -50 to 50 (1 unit = 0.084 mm = 300 dpi).

(Shifted down when the value is negative)

### <Operating Procedure>

- (1) Press the [4], and then the [5] in the initial state of maintenance mode. For models without keypad, press the [▲] or [▼] to display "MAINTENANCE 45" on the LCD and press the [OK]. "USBNo." is displayed on the LCD.
- (2) Press the [▲] or [▼] to display "Y Adjust" on the LCD, and press the [SET] or [OK]. "YAdjust MP" is displayed on the LCD.
- (3) Refer to <Adjustment option table> in the table below, press the [▲] or [▼] to select from the adjustment options, and press the [SET] or [OK]. "YAdj. \*\*= 0\*" is displayed on the LCD. (Selected option is shown for \*\*.)
- (4) To shift the writing start position down, press the [▼] to decrease the value. To shift the position up, press the [▲] to increase the value.
- (5) Press the [SET] or [OK] after adjusting the value. "Accepted" is displayed on the LCD.
- (6) Press the [X] or [Stop], and the machine returns to the initial state of maintenance mode.

#### <Adjustment option table>

##### Single-side printing

Adjustment option	LCD
MP tray first side	Y Adjust MP
Paper tray first side	Y Adjust T1
*1	Y Adjust TRAY
N/A (disabled)	Y Adjust DX
N/A (disabled)	Y Adjust DXMP
N/A (disabled)	Y Adjust DXT1

##### Duplex printing

Adjustment option	LCD
MP tray second side	Y Adjust MP
Paper tray second side	Y Adjust T1
*2	Y Adjust TRAY
*1	Y Adjust DX
MP tray first side	Y Adjust DXMP
Paper tray first side	Y Adjust DXT1

\*1 Adjusts first side print start position of all tray (paper tray and MP tray). Value of Y Adjust TRAY and Y Adjust DX is added to each tray adjustment value.  
For example, when printing from paper tray, it adjusts as "Y Adjust T1 value" + "Y Adjust TRAY value" or "Y Adjust DXT1 value" + "Y Adjust DX value" and print. Besides, when the added value is over than the adjustable range (-50 to 50), adjusted value will be for minimum -50 and maximum 50 and does not become out of adjustable range.

\*2 Adjusts second side print start position of all tray (paper tray and MP tray). Value of Y Adjust TRAY is added to each tray adjustment value.  
For example, when printing from paper tray, it adjusts as "Y Adjust T1 value" + "Y Adjust TRAY value" and print. Besides, when the added value is over than the adjustable range (-50 to 50), adjusted value will be for minimum -50 and maximum 50 and does not become out of adjustable range.

## ■ Change ON/OFF setting for lower case compensation

### <Function>

This function is used to expand and compensate the white lower case which is easily collapsed by the pattern matching.

### <Operating Procedure>

- (1) Press the [4], and then the [5] in the initial state of maintenance mode. For models without keypad, press the [▲] or [▼] to display "MAINTENANCE 45" on the LCD and press the [OK]. "USBNo." is displayed on the LCD.
- (2) Press the [▲] or [▼] to display "Dot Correct" on the LCD, and press the [SET] or [OK]. "Dot Correct = ON\*" is displayed on the LCD.
- (3) Press the [▲] or [▼] to select "Dot Correct = ON" or "Dot Correct = OFF", and press the [SET] or [OK]. "Accepted" is displayed on the LCD, and the machine returns to the initial state of maintenance mode.

## ■ Change ON/OFF setting for fixation strength improvement

### <Function>

When the fuser unit does not reach the target temperature and the fixation strength can not be secured due to an external factor such as the power source environment is poor, this function provides a mode which can secure the fixation strength by checking the fuser temperature before feeding.

### <Operating Procedure>

- (1) Press the [4], and then the [5] in the initial state of maintenance mode. For models without keypad, press the [▲] or [▼] to display "MAINTENANCE 45" on the LCD and press the [OK]. "USBNo." is displayed on the LCD.
- (2) Press the [▲] or [▼] to display "Fix Intensity up" on the LCD, and press the [SET] or [OK]. "Fix Mode = OFF\*" is displayed on the LCD.
- (3) Press the [▲] or [▼] to select "Fix Mode = ON" or "Fix Mode = OFF", and press the [SET] or [OK]. "Accepted" is displayed on the LCD, and the machine returns to the initial state of maintenance mode.

### 1.3.13 Adjust printable range for each speed level (Function code 46)

#### <Function>

This function is to adjust the printing position in horizontal / vertical direction.

Position can be adjusted in 11 steps from -0.5% to 0.5% (Printing width gets smaller when the value is negative).

#### <Operating Procedure>

- (1) Press the [4], and then the [6] in the initial state of maintenance mode. For models without keypad, press the [▲] or [▼] to display "MAINTENANCE 46" on the LCD and press the [OK]. "MAIN SIZE SET" is displayed on the LCD.
- (2) Press the [▲] or [▼] to display "PRINT TEST PTN" on the LCD, and press the [SET] or [OK]. "PRINTING" is displayed on the LCD, and the print adjustment test pattern (refer to the [next page](#)) is printed on a sheet of paper.
- (3) Adjust the line so that the width is 10 mm in horizontal / vertical direction. Press the [▲] or [▼] to display desired direction on the LCD.
  - Horizontal direction→ "MAIN SIZE SET"
  - Vertical direction→ "SUB SIZE SET"

Press the [SET] or [OK]. "SET: 0.0 %" is displayed on the LCD.

- (4) To make the print width smaller, press the [▼] to decrease the value. Press the [SET] or [OK] after adjusting the value.
- (5) After adjustment, repeat the procedure (2) to check if the adjustment was correctly done.
- (6) Press the [X] or [Stop] to return the machine to the initial state of maintenance mode after adjusting the value.

■ Print adjustment test pattern

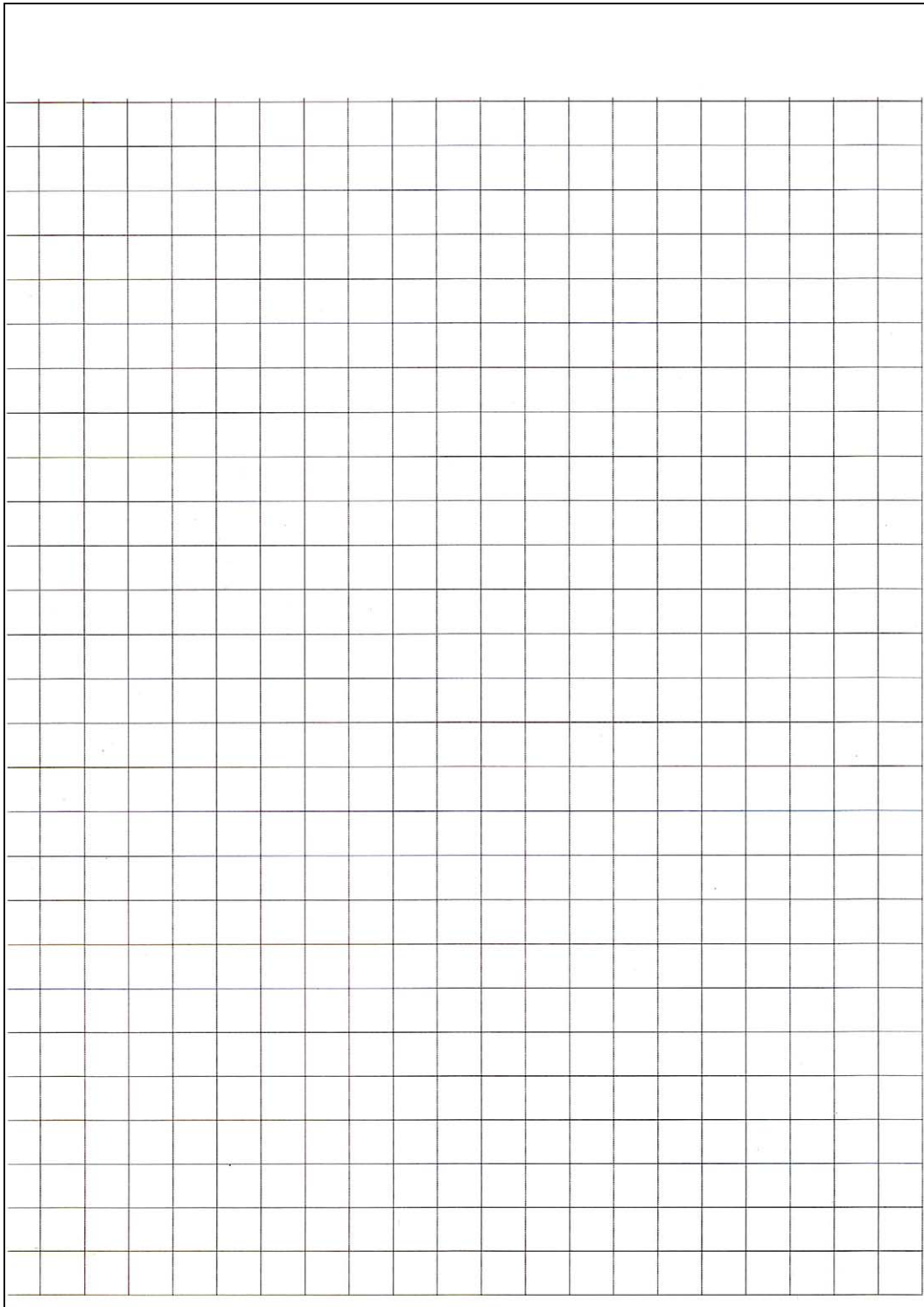


Fig. 5-11



### 1.3.14 Transfer received fax data / log information (fax models only) (Function code 53)

#### <Function>

When the machine is unable to print the received fax data due to an error in the printing mechanism, this function is used to transfer the data to another machine. The communication management report, communication list, or machine log information can also be transferred.

#### **Note:**

- The number of files that can be transferred in one operation is up to 99. When there are 100 or more files, the operation procedure below must be performed several times to transfer all files.
- When there are both color data files and monochrome data files, monochrome data files are transferred first. When the color function is not supported by the receiver machine, color data files cannot be transferred and an error occurs.

#### <Operating Procedure>

- (1) Press the [5], and then the [3] in the initial state of maintenance mode. "FAX TRANSFER" is displayed on the LCD.
  - To check the number of files received, press the [1].  
"1. NO. OF JOBS" is displayed on the LCD.  
Press the [SET] or [OK], and the number of files received is displayed, for example, "NO. OF JOBS: 10".
  - To transfer only the communication management report, press the [2].  
"2. ACTIVITY" is displayed on the LCD.
  - To transfer the received data, press the [3].  
(The communication management report is also transferred.)  
"3. DOCUMENTS" is displayed on the LCD. If there are no received files, "NO DOCUMENTS" is displayed.
  - To transfer the communication list (latest communication information), press the [4].  
"4. COM.LIST (NEW)" is displayed on the LCD.
  - To transfer the communication list (information for the past three errors), press the [5].  
"5. COM.LIST (ERR3)" is displayed on the LCD.
  - To transfer the maintenance information (list printed by function code 77), press the [6].  
"6. MNT77LIST" is displayed on the LCD.
- (2) Press the [SET] or [OK] while either "2.ACTIVITY", "3.DOCUMENTS", "4.COM.LIST (NEW)", "5.COM.LIST (ERR3)", or "6.MNT77LIST" is displayed on the LCD. "ENTER NO. & SET" is displayed on the LCD.
- (3) Enter the telephone number of the receiver machine, and press the [SET] or [OK] again.
- (4) "Accepted" is displayed for approximately two seconds, and the machine starts dialing to transfer the received data.

#### **Note:**

- Be sure to enter the telephone number directly using the numerical keys. One-touch dialing is not allowed in this procedure.
- No station ID will be attached to the data to be transferred. Instead, a cover page and end page as shown on the [next page](#) will be automatically attached.

■ Cover page example

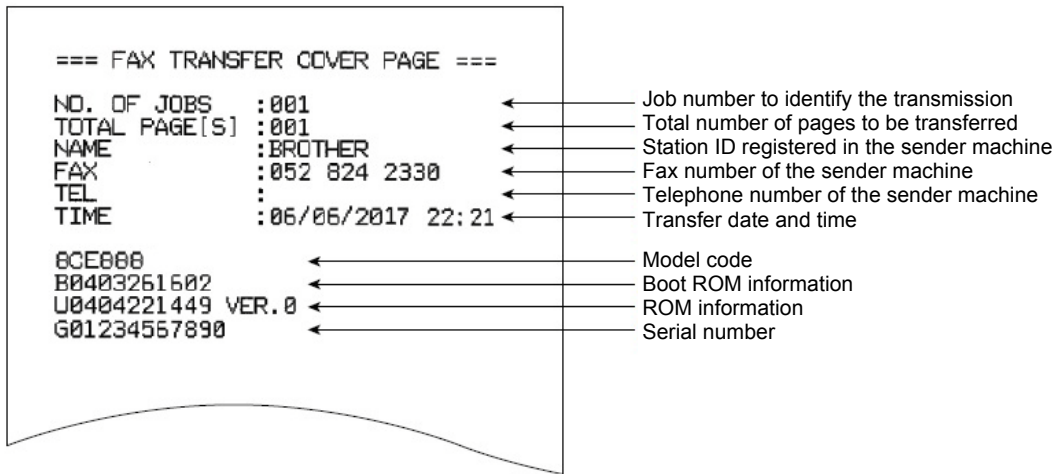


Fig. 5-12

■ End page example

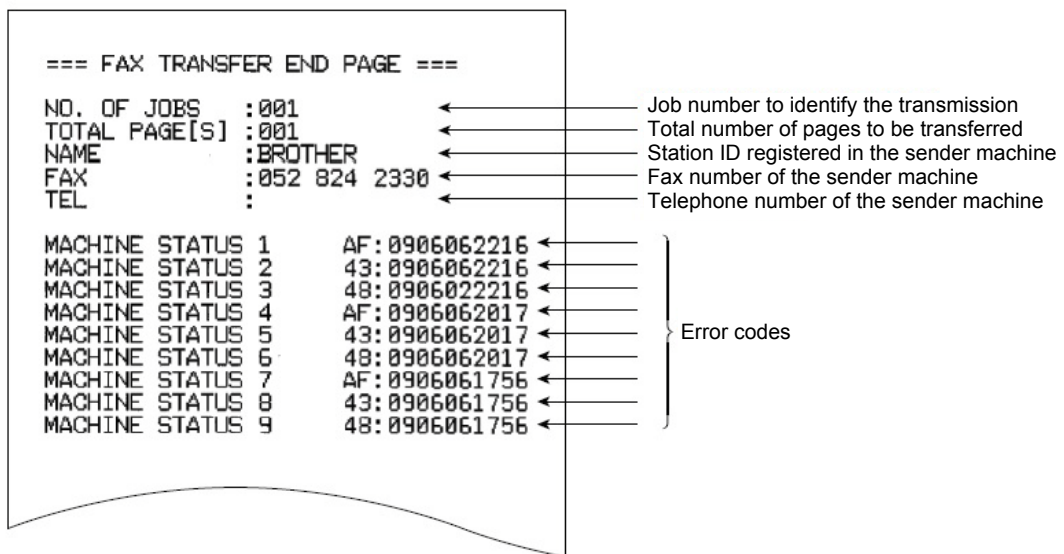


Fig. 5-13

### 1.3.15 Fine-tune scanning position (Function code 54)

#### <Function>

This function is used to adjust the scanning start/end positions.

#### <Operating Procedure>

- (1)
    - For models with ADF and keypad  
Press the [5], and then the [4] in the initial state of maintenance mode. "SCAN START ADJ" is displayed for two seconds, and then "0: ADF 1: FB" is displayed on the LCD. To adjust the ADF scanning position, press the [0] and proceed to the procedure (2). To adjust the FB scanning position, press the [1] and proceed to the procedure (3).
    - For models with ADF but no keypad  
Press the [▲] or [▼] to display "MAINTENANCE 54" on the LCD and press the [OK]. "SCAN START ADJ" is displayed on the LCD for two seconds and "▲: ADF ▼: FB" appears. To adjust the ADF scanning position, press the [▲] and proceed to the procedure (2). To adjust the FB scanning position, press the [▼] and proceed to the procedure (3).
    - For models without ADF, proceed to the procedure (2).
  - (2) "0:MAIN 1:TP 2:HP" is displayed on the LCD. Press the [0] to adjust the main scanning. Press the [1] to adjust the vertical scanning. Press the [2] to adjust the rear end side of the vertical scanning.
    - For duplex scanning models  
"0:FRONT 1:BACK" is displayed on the LCD. Press the [0] to adjust the first side. Press the [1] to adjust the second side. Proceed to the procedure (4).
    - For single-side scanning models  
Proceed to the procedure (4).
  - (3) "0:MAIN 1:SUB" is displayed on the LCD. Press the [0] to adjust the main scanning. Press the [1] to adjust the vertical scanning, and proceed to the procedure (4).
  - (4) The currently set value is displayed on the LCD. To increase the adjustment value, press the [▲]. To decrease the adjustment value, press the [▼]. (Refer to the figure below)
- Note:**
- When the [X] is pressed, the machine stops correcting the adjusting value and returns to the initial state of maintenance mode.
- (5) Press the [SET] after adjusting the value. "Accepted" is displayed on the LCD, and the machine returns to the initial state of maintenance mode.

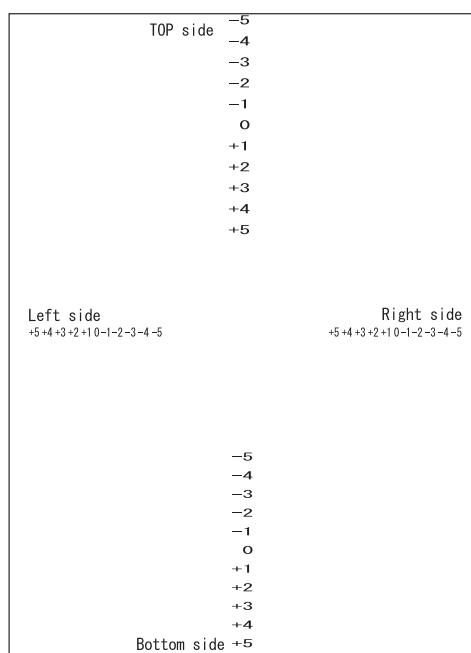


Fig. 5-14

### 1.3.16 Acquire white level data and set CIS scan area (Function code 55)

#### <Function>

This function is used to acquire the white level of the CIS unit, and store this data and the scan area in the EEPROM of the main PCB.

#### <Operating Procedure>

- (1) Press the [5] twice in the initial state of maintenance mode. For models without keypad, press the [▲] or [▼] to display "MAINTENANCE 55" on the LCD and press the [OK]. "Press START" is displayed on the LCD.
- (2) Press the [Start] or [Mono Start]. "SCANNER AREA SET" is displayed on the LCD, and the white level data is obtained.
- (3) After several seconds, the compensation value for the white level data/scanning width is stored in the EEPROM, and the machine returns to the initial state of maintenance mode.

### 1.3.17 Check toner cartridge (Models with cartridge sensor only) (Function code 57)

#### <Function>

This function is used to acquire the toner cartridge data and check whether the country code is right and it is compatible with the machine and capacity. Also checks the toner cartridge version and the continuity (contact).

#### <Operating Procedure>

##### ■ Compatibility check

- (1) Press the [5], and then the [7] in the initial state of maintenance mode. For models without keypad, press the [▲] or [▼] to display "MAINTENANCE 57" on the LCD and press the [OK]. "IC\_ACT ALL" is displayed on the LCD.
- (2) Press the [1]. For models without keypad, press the [▲] or [▼] to display "1" on the LCD and press the [OK]. "IC\_ACT ALL" is displayed on the LCD.
- (3) Press the [▲] or [▼] and select the desired item from "Black", "Main", or "ALL" to display.  
Black: Checks the cartridge sensor on the toner cartridge side.  
Main: Checks the cartridge sensor on the machine side.  
ALL: Checks the cartridge sensor on the toner cartridge side and machine side.
- (4) Press the [Start] or [OK]. Perform the compatibility check with the machine. If it is compatible, "IC\_ACT OK" is displayed on the LCD. If it is not compatible, an error in the <Error display> table below is displayed on the LCD.

#### <Error display>

LCD	Description
NG0 to 99	Cartridge sensor on the machine is faulty. Cartridge sensor PCB ASSY has to be replaced with a new one.
NG100 to 199	Could not communicate with the cartridge sensor on the toner cartridge. Cartridge sensor contact is faulty or broken. Toner cartridge without the cartridge sensor is installed.
NG200 to 299	Communication between the toner cartridge and cartridge sensor shows error. Toner cartridge may not be a genuine product.
NG300 to 399	Communication and authentication of the cartridge sensor was performed successfully but the cartridge information was deemed incompatible. Toner cartridge may not be installed correctly.

##### ■ Color check

- (1) Press the [5], and then the [7] in the initial state of maintenance mode. For models without keypad, press the [▲] or [▼] to display "MAINTENANCE 57" on the LCD and press the [OK]. "IC\_ACT ALL" is displayed on the LCD.
- (2) Press the [2]. For models without keypad, press the [▲] or [▼] to display "2" on the LCD and press the [OK]. "IC\_COL ALL" is displayed on the LCD.
- (3) Press the [▲] or [▼] and select the desired item from "Black", "Main", or "ALL" to display.  
Black: Checks the cartridge sensor on the toner cartridge side.  
Main: Checks the cartridge sensor on the machine side.  
ALL: Checks the cartridge sensor on the toner cartridge side and machine side.
- (4) Press the [Start] or [OK]. Perform the compatibility check with the machine. If it is compatible, "IC\_COL OK" is displayed on the LCD. If it is not compatible, an error in the <Error display> table above is displayed on the LCD.

### ■ Destination check

- (1) Press the [5], and then the [7] in the initial state of maintenance mode. For models without keypad, press the [▲] or [▼] to display "MAINTENANCE 57" on the LCD and press the [OK]. "IC\_ACT ALL" is displayed on the LCD.
- (2) Press the [3]. For models without keypad, press the [▲] or [▼] to display "3" on the LCD and press the [OK]. "IC\_AREA ALL" is displayed on the LCD.
- (3) Press the [▲] or [▼] and select the desired item from "Black", "Main", or "ALL" to display.  
Black: Checks the cartridge sensor on the toner cartridge side.  
Main: Checks the cartridge sensor on the machine side.  
ALL: Checks the cartridge sensor on the toner cartridge side and machine side.
- (4) Press the [Start] or [OK]. Perform the compatibility check with the machine. If it is compatible, "IC\_AREA OK" is displayed on the LCD. If it is not compatible, an error in the <Error display> table on the previous page is displayed on the LCD.

### ■ Capacity check

- (1) Press the [5], and then the [7] in the initial state of maintenance mode. For models without keypad, press the [▲] or [▼] to display "MAINTENANCE 57" on the LCD and press the [OK]. "IC\_ACT ALL" is displayed on the LCD.
- (2) Press the [4]. For models without keypad, press the [▲] or [▼] to display "4" on the LCD and press the [OK]. "IC\_SIZE ALL" is displayed on the LCD.
- (3) Press the [▲] or [▼] and select the desired item from "Black", "Main", or "ALL" to display.  
Black: Checks the cartridge sensor on the toner cartridge side.  
Main: Checks the cartridge sensor on the machine side.  
ALL: Checks the cartridge sensor on the toner cartridge side and machine side.
- (4) Press the [Start] or [OK]. Perform the compatibility check with the machine. If it is compatible, "IC\_SIZE OK" is displayed on the LCD. If it is not compatible, an error in the <Error display> table on the previous page is displayed on the LCD.

### ■ Version information check

- (1) Press the [5], and then the [7] in the initial state of maintenance mode. For models without keypad, press the [▲] or [▼] to display "MAINTENANCE 57" on the LCD and press the [OK]. "IC\_ACT ALL" is displayed on the LCD.
- (2) Press the [5]. For models without keypad, press the [▲] or [▼] to display "5" on the LCD and press the [OK]. "IC\_VER BLACK" is displayed on the LCD.
- (3) Press the [▲] or [▼] and select the desired item from "Black", "Main", or "ALL" to display.  
Black: Checks the cartridge sensor on the toner cartridge side.  
Main: Checks the cartridge sensor on the machine side.  
ALL: Checks the cartridge sensor on the toner cartridge side and machine side.
- (4) Press the [Start] or [OK]. Perform the compatibility check with the machine. If it is compatible, "IC\_VER OK" is displayed on the LCD. If it is not compatible, an error in the <Error display> table on the previous page is displayed on the LCD.

### ■ Continuity (contact) check

- (1) Press the [5], and then the [7] in the initial state of maintenance mode. For models without keypad, press the [▲] or [▼] to display "MAINTENANCE 57" on the LCD and press the [OK]. "IC\_ACT ALL" is displayed on the LCD.
- (2) Press the [0]. For models without keypad, press the [▲] or [▼] to display "0" on the LCD and press the [OK]. "IC\_TX ALL" is displayed on the LCD.
- (3) Press the [▲] or [▼] and select the desired item from "Black", "Main", or "ALL" to display.  
Black: Checks the cartridge sensor on the toner cartridge side.  
Main: Checks the cartridge sensor on the machine side.  
ALL: Checks the cartridge sensor on the toner cartridge side and machine side.
- (4) Press the [Start] or [OK]. Perform the compatibility check with the machine. If it is compatible, "IC\_TX OK" is displayed on the LCD. If it is not compatible, an error in the <Error display> table on the previous page is displayed on the LCD.

### 1.3.18 Adjust touch panel (Function code 61)

#### <Function>

This function is used to adjust the touch panel.

#### Note:

This adjustment requires a touch pen with a thin tip. A commercially available touch pen designed for electronic dictionaries or personal digital assistance (PDA) can be used. If one is not available at hand, order a "Touch pen" from Brother's parts list.

#### <Operating Procedure>

- (1) Press the [6], and then the [1] in the initial state of maintenance mode. The adjustment screen shown below appears on the LCD.
- (2) Use a touch pen and touch the center on the mark at the upper left corner of the screen. The mark disappears when touched, then touch the mark at the lower left. Similarly touch the mark at the lower right, upper right and center.

#### Note:

- Do not use any tools other than a touch pen. In particular, never use a pointed tool (e.g., screwdriver). Using such a tool will damage the touch panel.
- Do not touch the touch panel with your fingers. The contact area of a finger is too large to adjust the touch panel precisely.
- If no operation is performed for one minute or the [X] is pressed, the machine returns to the initial state of maintenance mode.

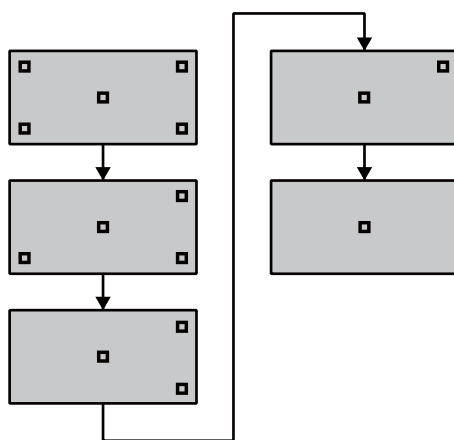


Fig. 5-15

- (3) When the center (the 5th mark) is touched, "OK" is displayed on the LCD if the specified area is adjusted correctly. The machine returns to the initial state of maintenance mode.

#### Note:

If "NG" is still displayed on the LCD even after this operation is repeated two to three times, check the connection of the touch panel flat cable. If the LCD keeps displaying "NG" even there is no problem, replace the panel PCB ASSY.

### 1.3.19 Continuous print test (Function code 67)

#### <Function>

This function is used to conduct paper feed and eject tests while printing patterns.

#### <Operating Procedure>

- (1) Press the [6], and then the [7] in the initial state of maintenance mode. For models without keypad, press the [▲] or [▼] to display "MAINTENANCE 67" on the LCD and press the [OK]. "SELECT: K 100%" is displayed on the LCD.
- (2) Refer to the <Print pattern> table, press the [▲] or [▼] to select the print pattern, and press the [SET] or [OK]. "SELECT: A4" is displayed on the LCD.
- (3) Refer to the <Paper size> table, press the [▲] or [▼] to select the paper size, and press the [SET] or [OK]. "SELECT: PLAIN" is displayed on the LCD.
- (4) Refer to the <Print specification> table, press the [▲] or [▼] to select the media specification, and press the [SET] or [OK]. "SELECT: TRAY1 SX" is displayed on the LCD.
- (5) Refer to the <Print type> table, press the [▲] or [▼] to select the print type, and press the [SET] or [OK]. "SELECT: 1PAGE" is displayed on the LCD.
- (6) Refer to the <Print page> table, press the [▲] or [▼] to select the pages printing, and press the [SET] or [OK]. For intermittent pattern printing, "SELECT: 1P/JOB" is displayed on the LCD. For other printings, or move on to the procedure (8).
- (7) Refer to the <Number of pages per job> (Only for intermittent pattern printing) table, press the [▲] or [▼] to select the number of pages for 1 job, and press the [SET] or [OK].
- (8) "PAPER FEED TEST" is displayed on the LCD, and printing test pattern starts using the selected conditions.
- (9) When you press the [X] or [Stop], test pattern printing is stopped, and the machine returns to the initial state of maintenance mode.

#### <Print pattern>

LCD	Description
SELECT: K 100%	Black 100% solid print
SELECT: W 100%	White 100% solid print
SELECT: K1%	1% intermittent pattern print <sup>*1</sup>
SELECT: K5%	5% intermittent pattern print <sup>*1</sup>
SELECT: Lattice	Lattice print
SELECT: Total	Total pattern print <sup>*2</sup>

<sup>\*1</sup> Up to 500 sheets in one-sided printing and 1,000 sheets in two-sided printing in the case of job printing.

<sup>\*2</sup> Printing method and number of sheets to be printed are not selectable when the general pattern printing is chosen.



**<Paper size>**

LCD	Description
SELECT: A4	A4
SELECT: LETTER	Letter
SELECT:ISOB5	ISO B5
SELECT:JISB5	JIS B5
SELECT:A5	A5
SELECT:A5L	A5L
SELECT:JISB6	JIS B6
SELECT:A6	A6
SELECT:EXECUTE	Executive size
SELECT:LEGAL	Legal size
SELECT:FOLIO	Folio size
SELECT:HAGAKI	Postcard size *

\* Supports only for TRAY1 SX, MP TRAY SX and AUTO SX.

**<Print specification>**

LCD	Description
SELECT: PLAIN	Plain paper
SELECT: THIN	Plain paper (thin)
SELECT: THICK	Plain paper (thick)
SELECT:THICKER	Plain paper (thicker)
SELECT:RECYCLED	Recycled paper
SELECT:BOND	Bond paper
SELECT:LABEL	Label
SELECT:ENVELOPE	Envelope
SELECT:ENVTHIN	Envelope (thin)
SELECT:ENVTHICK	Envelope (thick)
SELECT:GLOSSY	Glossy paper
SELECT:HAGAKI	Postcard *

\* Display appears on LCD, but it is not available.

**<Print type>**

LCD	Description
SELECT: TRAY1 SX	Single-side printing from paper tray
SELECT: MP SX	Single-side printing from MP tray
SELECT: MF SX	Single-side printing from manual feed slot
SELECT: TRAY1 DX *	Duplex printing from paper tray
SELECT: MP DX *	Duplex printing from MP tray
SELECT: MF DX *	Duplex printing from manual feed slot
SELECT: AUTO SX	Single-side printing to automatically selected tray
SELECT: AUTO DX *	Double-side printing to automatically selected tray

\* Supports paper size only for A4, Letter, Legal and Folio.

**<Print page>**

LCD	Description
SELECT: 1PAGE	1-page printing
SELECT: CONTINUE	Continuous printing
SELECT: JOB	Intermittent printing per job *

\* Selectable only when the printing pattern is set to "K1%" or "K5%", and the print type is not set to the manual feed slot.

**<Number of pages per job> (Only for intermittent pattern printing)**

LCD	Description
SELECT: 1P/JOB	Prints 1 page per job * <sup>1</sup>
SELECT: 2P/JOB	Prints 2 pages per job * <sup>1</sup>
SELECT: 5P/JOB	Prints 5 pages per job * <sup>1</sup>
SELECT: 2I/JOB	Prints 2 images per job * <sup>2</sup>
SELECT: 5I/JOB	Prints 5 images per job * <sup>2</sup> * <sup>3</sup>
SELECT: 10I/JOB	Prints 10 images per job * <sup>2</sup>

\*<sup>1</sup> Selectable only when SX is selected as print type.

\*<sup>2</sup> Selectable only when DX is selected as print type.

\*<sup>3</sup> One-sided printing for the 5th page.

■ Print pattern

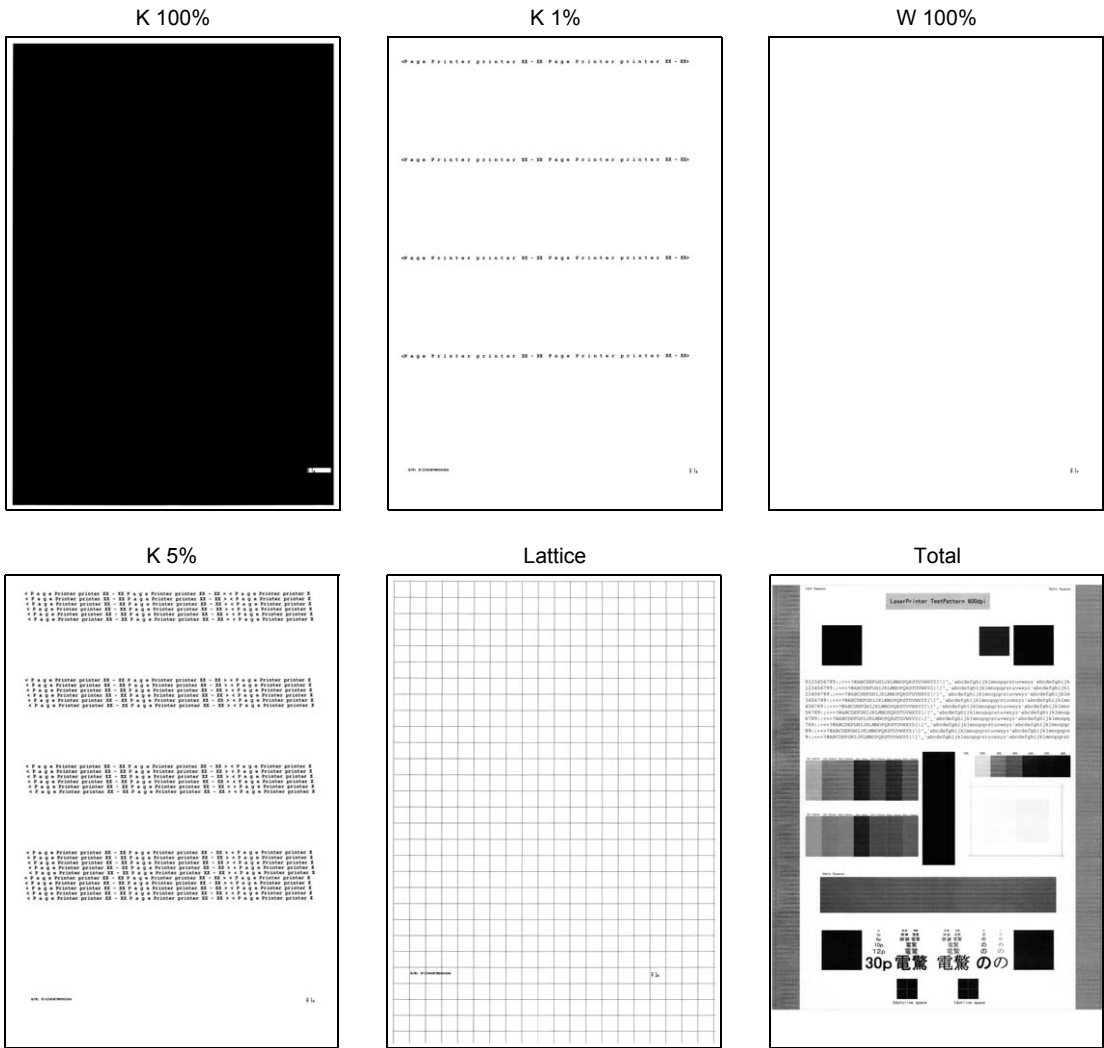


Fig. 5-16

### 1.3.20 Print frame pattern (single-side printing) (Function code 69)

#### <Function>

This function is used to print the frame pattern on single side of the paper to check for printing flaws and omission.

#### <Operating Procedure>

- (1) Set the paper specified in the default paper settings (A4 or Letter) to the paper tray.
- (2) Press the [6], and then the [9] in the initial state of maintenance mode. For models without keypad, press the [▲] or [▼] to display “MAINTENANCE 69” on the LCD and press the [OK]. “PRINTING” is displayed on the LCD, and the frame pattern (refer to the figure below) is printed on single side of the paper.
- (3) When printing is completed, “WAKU SX” is displayed on the LCD.
- (4) Press the [X] or [Stop], and the machine returns to the initial state of maintenance mode.

#### Note:

If printing fails, printing is stopped with displaying any of the errors shown in the table below. To retry printing, refer to the “Remedy” in the table below and eliminate the error cause and press the [Start] or [Mono Start]. “PRINTING” is displayed on the LCD, and the frame pattern is printed on a single sheet of paper.

Error display	Remedy
Replace Toner	Replace the toner cartridge and press the [Start] or [Mono Start] to release the error.
Cover is Open	Close the Front cover.
No Paper	Refill the paper, close the paper tray and press the [Start] or [Mono Start] to release the error.
Jam Tray1	Remove the jammed paper, then close the paper tray and all covers, press the [Start] or [Mono Start] to release the error.
Jam Rear	

#### ■ Frame pattern

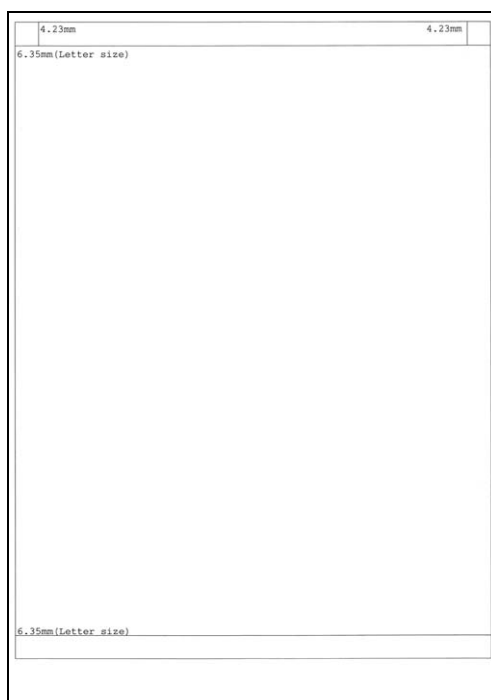


Fig. 5-17

### 1.3.21 Print frame pattern (duplex printing) (Function code 70)

#### <Function>

This function is used to print the frame pattern on both sides of the paper to check for printing flaws and omission.

#### <Operating Procedure>

- (1) Set the paper specified in the default paper settings (A4 or Letter) to the paper tray.
- (2) Press the [7], and then the [0] in the initial state of maintenance mode. For models without keypad, press the [▲] or [▼] to display "MAINTENANCE 70" on the LCD and press the [OK]. "PRINTING" is displayed on the LCD, and the frame pattern (refer to the figure below) is printed on both sides of the paper.
- (3) When printing is completed, "WAKU DX" is displayed on the LCD.
- (4) Press the [X] or [Stop], and the machine returns to the initial state of maintenance mode.

#### Note:

If printing fails, printing is stopped with displaying any of the errors shown in the table below. To retry printing, refer to the "Remedy" in the table below and eliminate the error cause and press the [Start] or [Mono Start]. "PRINTING" is displayed on the LCD, and the frame pattern is printed on both sides of a sheet of paper.

Error display	Remedy
Replace Toner	Replace the toner cartridge and press the [Start] or [Mono Start] to release the error.
Cover is Open	Close the Front cover.
No Paper	Refill the paper, close the paper tray and press the [Start] or [Mono Start] to release the error.
Jam Tray1	Remove the jammed paper, then close the paper tray and all covers, press the [Start] or [Mono Start] to release the error.
Jam Rear	
Jam Duplex	
Duplex Disabled	Refill the paper, then close the paper tray and all covers, press the [Start] or [Mono Start] to release the error.

#### ■ Frame pattern

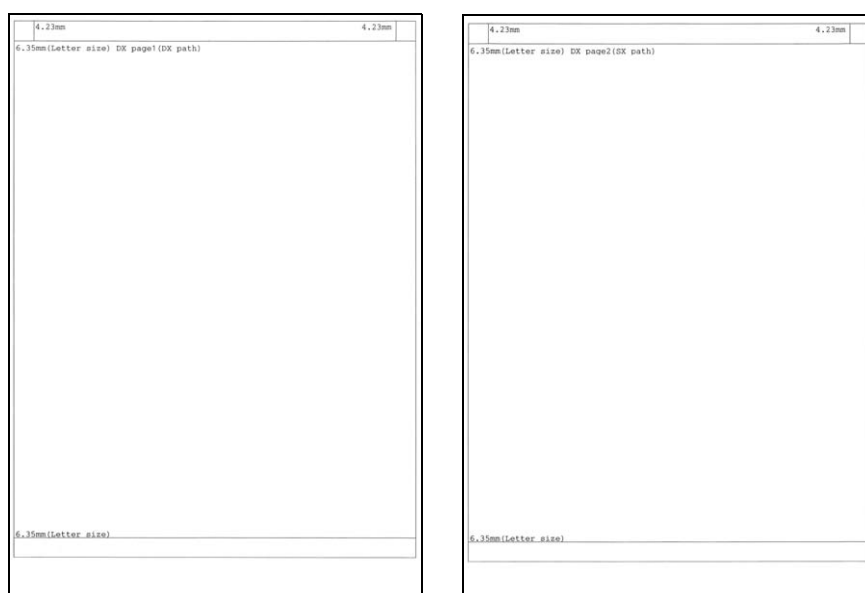


Fig. 5-18

### 1.3.22 Test pattern (Function code 71)

#### <Function>

This function is used to print the test pattern to check whether the develop roller or exposure drum is dirty or damaged.

#### <Operating Procedure>

- (1) Press the [7], and then the [1] in the initial state of maintenance mode. For models without keypad, press the [▲] or [▼] to display "MAINTENANCE 71" on the LCD and press the [OK]. "SELECT: LETTER" is displayed on the LCD.
- (2) Refer to the <Paper size> table, press the [▲] or [▼] to select the paper size, and press the [SET] or [OK]. "SELECT: PLAIN" is displayed on the LCD.
- (3) Refer to the <Print specification> table, press the [▲] or [▼] to select the media specification, and press the [SET] or [OK]. "SELECT: SX" is displayed on the LCD.
- (4) Refer to the <Print type> table, press the [▲] or [▼] to select the print type, and press the [SET] or [OK]. "SELECT: 1PAGE" is displayed on the LCD.
- (5) Refer to the <Print page> table, press the [▲] or [▼] to select the pages printing, and press the [SET] or [OK]. "PRINTING" is displayed on the LCD, and printing test pattern starts using the selected conditions.
- (6) When printing is completed, "OK" is displayed on the LCD.  
To perform again, press the [Start] or [Mono Start]. When "2D3S K" appears on the LCD, press the [Start] or [Mono Start] again and start from the procedure (2).
- (7) Press the [X] or [Stop], and the machine returns to the initial state of maintenance mode.

#### Note:

If printing fails, printing is stopped with displaying any of the errors shown in the <Error display> table. To retry printing, refer to the "Remedy" in the table, eliminate the error cause and press the [Start] or [Mono Start]. "PRINTING" is displayed on the LCD, and the test pattern is printed.

#### <Paper size>

LCD	Description
SELECT: LETTER	Letter
SELECT: A4	A4
SELECT:ISOB5	ISO B5
SELECT:JISB5	JIS B5
SELECT:A5	A5
SELECT:A5L	A5L
SELECT:JISB6	JIS B6
SELECT:A6	A6
SELECT:EXECUTE	Executive size
SELECT:LEGAL	Legal size
SELECT:FOLIO	Folio size
SELECT:HAGAKI	Postcard size

**<Print specification>**

LCD	Description
SELECT: PLAIN	Plain paper
SELECT: THICK	Plain paper (thick)
SELECT: THIN	Plain paper (thin)
SELECT: THICKER	Plain paper (thicker)
SELECT: RECYCLED	Recycled paper
SELECT: BOND	Bond paper
SELECT: LABEL	Label
SELECT: ENVELOPE	Envelope
SELECT: ENVTHIN	Envelope (thin)
SELECT: ENVTHICK	Envelope (thick)
SELECT: HAGAKI	Postcard

**<Print type>**

LCD	Description
SELECT: SX	Single-side printing from paper tray
SELECT: DX*	Duplex printing from paper tray

\* Supports paper size only for A4, Letter, Legal, and Folio in duplex printing.

**<Print page>**

LCD	Description
SELECT: 1PAGE	1-page printing
SELECT: CONTINUE	Continuous printing *

\* Press the [X] or [Stop] to end the continuous printing.

**<Error display>**

LCD	Description
Replace Toner	Replace the toner cartridge and press the [Start] or [Mono Start] to release the error.
Cover is Open	Close the Front cover.
No Paper	Refill the paper, close the paper tray and press the [Start] or [Mono Start] to release the error.
Jam Tray1	Remove the jammed paper, then close the paper tray and all covers, press the [Start] or [Mono Start] to release the error.
Jam Rear	

■ Test pattern

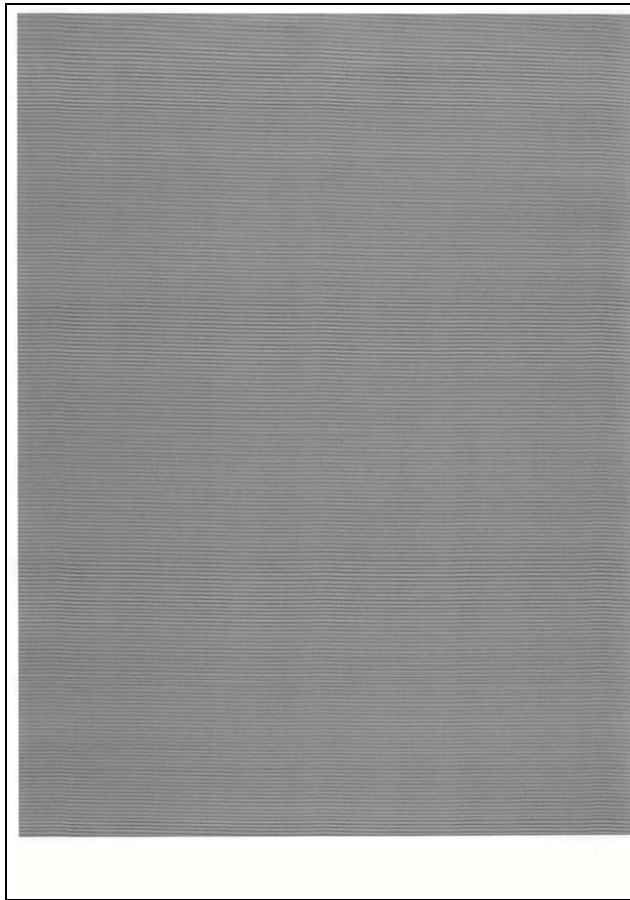


Fig. 5-19



### 1.3.23 Configure for country/region and model (Function code 74)

#### <Function>

This function is used to customize the machine according to language, function settings, and worker switch settings.

#### <Operating Procedure>

- (1) Press the [7], and then the [4] in the initial state of maintenance mode. For models without keypad, press the [▲] or [▼] to display "MAINTENANCE 74" on the LCD and press the [OK]. The spec code currently set is displayed on the LCD.
- (2) Enter the spec code (four digits) you want to set.  
For models without keypad, the first digit starts flashing. Press the [▲] to enter "1", or [▼] to enter "0" to select the number for the first digit and press the [OK]. The second digit starts flashing. Select the number by repeating the procedure above. The second digit is completed and the fourth digit starts flashing. Press the [▲] or [▼] to display numbers for the third and fourth digit on the LCD, then press the [OK].
- (3) Press the [Start] or [Mono Start] to save the new setting, and "PARAMETER INIT" is displayed on the LCD. The machine then returns to the initial state of maintenance mode.

#### Note:

If there is no entry for one minute or longer, the machine returns to the initial state of maintenance mode automatically, regardless of the display status.

#### ■ Setting by spec code list

MODEL	Country Code		Country Code (Detail)	
DCP-7090	China	0020	-	-
DCP-7095D	China	0120	-	-
DCP-7190DN	China	0020	-	-
DCP-7195DW	China	0220	-	-
DCP-B7500D	China	0220	-	-
	India	0245	-	-
DCP-B7520DW	Brazil	0242	-	-
	CEE-General	1250	Bulgaria	1250
			Croatia	1250
			Czech	1250
			Czech	0204
			Hungary	1250
			Poland	1250
			Romania	1250
			Slovakia	1250
			Slovenia	1250
Others	1250			
	China	0620	-	-
DCP-B7530DN	China	0120	-	-
DCP-B7535DW	Brazil	0742	-	-
	China	0720	-	-
	India	0745	-	-
	Indonesia	0729	India	0745
	Mexico	0746	-	-
	Vietnam/Indonesia	0729	-	-

MODEL	Country Code		Country Code (Detail)	
DCP-L2510D	France/Belgium/ Netherlands	1055	Belgium	1008
			France	7004
			Netherlands	9004
	Germany	0053	Austria	0014
			-	-
	Iberia	1004	Portugal	1004
			Spain	1004
	Italy	1004	-	-
	Pan-Nordic	1004	Denmark	1004
			Finland	1004
			Norway	1004
Sweden			1004	
Others			1004	
UK	1004	-	-	
DCP-L2510DR	Russia	0048	-	-
DCP-L2511D	India	0045	-	-
DCP-L2512D	CEE-General	1050	Bulgaria	1050
			Croatia	1050
			Czech	1050
			Hungary	1050
			Poland	1050
			Romania	1050
			Slovakia	1050
			Slovenia	1050
			Others	1050
DCP-L2530DW	Argentina	0036	-	-
	Brazil	0042	-	-
	Chile	0036	Argentina	0036
	France/Belgium/ Netherlands	1055	Belgium	1008
			France	7004
			Netherlands	9004
	Germany	0053	Austria	0014
			-	-
	Iberia	1004	Portugal	1004
			Spain	1004
	Mexico	0046	-	-
	Pan-Nordic	1004	Denmark	1004
			Finland	1004
Norway			1004	
Sweden			1004	
Others			1004	
Switzerland	1004	-	-	
UK	1004	-	-	
		-	-	
DCP-L2530DWR	Russia	0048	-	-
DCP-L2531DW	India	0045	-	-

MODEL	Country Code		Country Code (Detail)	
DCP-L2532DW	CEE-General	1050	Bulgaria	1050
			Croatia	1050
			Czech	1050
			Hungary	1050
			Poland	1050
			Romania	1050
			Slovakia	1050
			Slovenia	1050
			Others	1050
DCP-L2535D	Asia	0140	Asia/Singapore	0140
	Gulf	0141	-	-
	Japan	0047	-	-
	Philippines	0121	-	-
DCP-L2535DW	Asia	0040	Asia/Singapore	0040
DCP-L2536D	Vietnam/Indonesia	0129	-	-
DCP-L2537DW	Pan-Nordic	1104	Denmark	1104
			Finland	1104
			Norway	1104
			Sweden	1104
			Others	1104
DCP-L2550DN	France/Belgium/ Netherlands	1355	Belgium	1308
			France	7304
			Netherlands	9304
	Germany	0353	Austria	0314
			-	-
	Iberia	1304	Portugal	1304
			Spain	1304
	Italy	1304	-	-
	Pan-Nordic	1304	Denmark	1304
			Finland	1304
			Norway	1304
Sweden			1304	
Others			1304	
Switzerland	1304	-	-	
DCP-L2550DNR	Russia	0348	-	-
DCP-L2550DW	Argentina	0436	-	-
	Asia	0440	Asia/Singapore	0440
	Brazil	0442	-	-
	Canada	0402	-	-
	Chile	0436	Argentina	0436
	Gulf	0441	-	-
	Japan	0047	-	-
	Philippines	0421	-	-
	Taiwan	0223	-	-
	U.S.A	0401	-	-
	DCP-L2551DN	Russia	0548	-
DCP-L2551DW	India	0445	-	-
	Mexico	0446	-	-
	Vietnam/Indonesia	0429	-	-

MODEL	Country Code		Country Code (Detail)	
DCP-L2552DN	CEE-General	1350	Bulgaria	1350
			Croatia	1350
			Czech	1350
			Hungary	1350
			Poland	1350
			Romania	1350
			Slovakia	1350
			Slovenia	1350
			Others	1350
FAX-L2710DN	Japan	0147	-	-
HL-L2390DW	Canada	0002	-	-
	U.S.A	0001	-	-
HL-L2395DW	Australia	0006	-	-
	Canada	0002	-	-
	U.S.A	0001	-	-
MFC-7390	China	0320	-	-
MFC-7490D	China	0420	-	-
MFC-7890DN	China	0320	-	-
MFC-7895DW	China	0620	-	-
MFC-B7700D	China	0520	-	-
MFC-B7715DW	CEE-General	0C88	Bulgaria	0C32
			Croatia	0C81
			Czech	0C37
			Hungary	0C38
			Poland	0C39
			Romania	0C33
			Slovakia	0C86
			Slovenia	0C82
			Others	0C50
	India	0C45	-	-
	Poland	0C39	-	-
	Vietnam/Indonesia	0C29	-	-
MFC-B7720DN	China	0420	-	-
MFC-L2690DW	U.S.A	0801	-	-
MFC-L2710DN	France	0905	-	-
	Germany	0953	Austria	0914
			-	-
	Israel	0917	-	-
	Italy	0916	-	-
	UK	0904	-	-
MFC-L2710DNR	Russia	0948	-	-

MODEL	Country Code		Country Code (Detail)	
MFC-L2710DW	Argentina	0A36	-	-
	Australia	0A06	-	-
	Belgium	0A08	-	-
	Brazil	0A42	-	-
	Canada	0A02	-	-
	Chile	0A36	Argentina	0A36
	France	0A05	-	-
	Germany	0A53	Austria	0A14
			-	-
	Iberia	0A65	Portugal	0A18
			Spain	0A15
	Israel	0A17	-	-
	Italy	0A16	-	-
	Mexico	0A46	-	-
	Netherlands	0A09	-	-
	Pan-Nordic	0A57	Denmark	0A13
			Finland	0A12
Norway			0A07	
Sweden			0A26	
Others			0A50	
Switzerland	0A10	-	-	
U.S.A	0A01	-	-	
UK	0A04	-	-	
MFC-L2710DWR	Russia	0A48	-	-
MFC-L2712DN	CEE-General	0988	Bulgaria	0932
			Croatia	0981
			Czech	0937
			Hungary	0938
			Poland	0939
			Romania	0933
			Slovakia	0986
			Slovenia	0982
			Others	0950
	Poland	0939	-	-
MFC-L2712DW	CEE-General	0A88	Bulgaria	0A32
			Croatia	0A81
			Czech	0A37
			Hungary	0A38
			Poland	0A39
			Romania	0A33
			Slovakia	0A86
			Slovenia	0A82
			Others	0A50
	Poland	0A39	-	-
MFC-L2713DW	Australia	0606	-	-
	New Zealand	0627	-	-
MFC-L2715D	Asia	0340	Asia/Singapore	0340
	Korea	0644	-	-
	Philippines	0321	-	-

MODEL	Country Code		Country Code (Detail)	
MFC-L2715DW	Asia	0A40	Asia/Singapore	0A40
	Gulf	0A41	-	-
	Korea	0544	-	-
	South Africa	0A24	-	-
	Taiwan	0523	-	-
MFC-L2716D	India	0345	-	-
	Vietnam/Indonesia	0329	-	-
MFC-L2716DW	India	0A45	-	-
	Turkey	1A25	-	-
	Vietnam/Indonesia	0A29	-	-
MFC-L2717DW	U.S.A	0B01	-	-
MFC-L2730DN	Japan	0047	-	-
MFC-L2730DW	Argentina	0336	-	-
	Australia	0306	-	-
	Brazil	0342	-	-
	Canada	0302	-	-
	Chile	0336	Argentina	0336
	France/Belgium/ Netherlands	0355	Belgium	0308
			France	0305
			Netherlands	0309
	Germany	0353	Austria	0314
			-	-
	Italy/Iberia	0366	-	-
			Portugal	0318
			Spain	0315
	Mexico	0346	-	-
	Pan-Nordic	0357	Denmark	0313
			Finland	0312
			Norway	0307
Sweden			0326	
Others			0350	
Switzerland	0310	-	-	
U.S.A	0301	-	-	
UK	0304	-	-	
MFC-L2730DWR	Russia	0348	-	-
MFC-L2732DW	CEE-General	0388	Bulgaria	0332
			Croatia	0381
			Czech	0337
			Hungary	0338
			Poland	0339
			Romania	0333
			Slovakia	0386
			Slovenia	0382
			Others	0350

MODEL	Country Code		Country Code (Detail)	
MFC-L2750DW	Argentina	0436	-	-
	Asia	0440	Asia/Singapore	0440
	Australia	0406	-	-
	Brazil	0442	-	-
	Canada	0402	-	-
	Chile	0436	Argentina	0436
	France/Belgium/ Netherlands	0455	Belgium	0408
			France	0405
			Netherlands	0409
	Germany	0453	Austria	0414
			-	-
	Italy/Iberia	0466	Italy	0416
			Portugal	0418
			Spain	0415
	Japan	0147	-	-
	Mexico	0446	-	-
	Pan-Nordic	0457	Denmark	0413
			Finland	0412
			Norway	0407
			Sweden	0426
Others			0450	
Philippines	0421	-	-	
Switzerland	0410	-	-	
U.S.A	0401	-	-	
UK	0404	-	-	
MFC-L2750DWR	Russia	0448	-	-
MFC-L2750DWXL	U.S.A	0401	-	-
MFC-L2751DW	Russia	0748	-	-
	Turkey	1425	-	-
MFC-L2752DW	CEE-General	0488	CZE	0437
			HUN	0438
			POL	0439
			BGR	0432
			ROM	0433
			SVK	0486
			SLO	0482
			CRO	0481
			GEN	0450
MFC-L2770DW	Asia	0540	Asia/Singapore	0540
	Australia	0506	-	-
	Korea	0544	-	-
	New Zealand	0527	-	-
	Philippines	0521	-	-
	Taiwan	0523	-	-
	MFC-L2771DW	Turkey	1525	-
Vietnam/Indonesia		0529	-	-

**Note:**

The spec code list above is current as of February 2019.  
Please contact Brother distributors for the latest information.





1	Model name	26	Total fax pages (Total / Duplex)
2	Serial number	27	Total pages printed by other methods (Total / Duplex)
3	Model code	28	Accumulated average coverage
4	Spec code	29	Average coverage by the current toner cartridge
5	Switch check sum (factory use) and comparison of default / current value	30	Average coverage by the previous toner cartridge
6	Main firmware version	31	Latest job average coverage
7	Sub firmware version	32	Drum page count / Rotations of the drum
8	Sub 5 firmware version	33	Total rotations of the develop roller (currently use / previously used toner cartridge)
9	Boot firmware version	34	Total printed pages per paper tray / paper size / paper type
10	Engine archive version	35	Printed pages per toner cartridge (current / previous)
11	USB product ID	36	Total rotations of the develop roller used in printing (currently use / previously used toner cartridge)
12	ROM check sum	37	Total number of paper jams / Paper jams by sections of the product
13	RTC (Real Time Clock) check	38	Machine error log / Total pages printed at the time of the error / Time of error
14	RTC (Real Time Clock) backup	39	Number of times each consumable has been replaced
15	RAM size	40	Scanned pages
16	Memory version	41	Communication error log
17	Result of function code 05 / Wireless LAN setting by country / Wireless LAN output peak / WLAN Setup YES/NO setting / Toner type (current) / Toner type (previous)	42	Developing bias voltage value
18	Main PCB inspection log / High voltage inspection log / The number of times that the discharge error / Fuser unit error / Polygon motor lock error / Irregular power supply detection error occurred / The number of times that the irregular power supply detection error occurred / Next power ON/OFF setting	43	Engine sensor log (Not necessary for maintenance)
19	Not necessary for maintenance (ADF sensor log)	44	Status log (Not necessary for maintenance)
20	Estimated remaining toner amount	45	Home position detection / Home position error display
21	Remaining life of drum unit	46	Total power distribution time / The number of times that the power is turned ON
22	Threshold setting rate when toner is running out	47	Start date for machine operation / Initial set date of RTC
23	Total printed pages (Total / Duplex)	48	Latest paper type used
24	Total copied pages (Total / Duplex)	49	New toner cartridge detection log
25	Total PC printed pages (Total / Duplex)	50	SSW information 1/2

### 1.3.25 Check fan operation (Function code 78)

#### <Function>

This function is used to check that the fan is operating normally. Switch the setting among rotation speed 100%, 50%, and OFF.

LCD	Name	Description
F	Fan	Emits the heat in the fuser unit.

#### <Operating Procedure>

- (1) Press the [7], and then the [8] in the initial state of maintenance mode. For models without keypad, press the [▲] or [▼] to display "MAINTENANCE 78" on the LCD and press the [OK]. "F100" is displayed on the LCD and the fan rotates at 100% speed.
- (2) By pressing the [Start] or [Mono Start], "F50" is displayed on the LCD and the fan rotates at 50% speed.
- (3) By pressing the [Start] or [Mono Start] again, "F 0" is displayed on the LCD and the fan stops.
- (4) Press the [X] or [Stop], and the machine returns to the initial state of maintenance mode.

#### ■ Location of fan

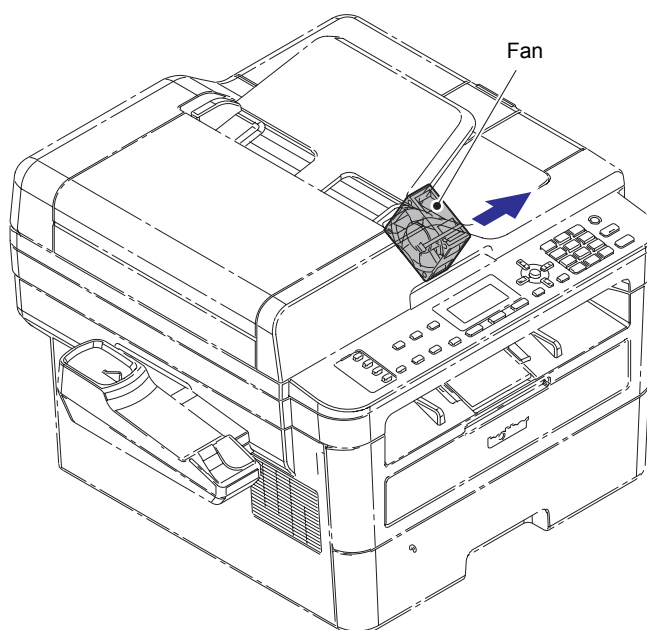


Fig. 5-21

### 1.3.26 Delete fax data (Function code 79)

#### <Function>

This function is used to delete fax data in the machine memory.

#### <Operating Procedure>

- (1) Press the [7], and then the [9] in the initial state of maintenance mode. "BACKUP CLEAR" is displayed on the LCD and fax data in the machine memory is deleted.
- (2) When deleting is completed, the machine returns to the initial state of maintenance mode.

### 1.3.27 Display machine log information (Function code 80)

#### <Function>

This function is used to display the log information on the LCD.

#### <Operating Procedure>

- (1) Press the [8], and then the [0] in the initial state of maintenance mode. For models without keypad, press the [▲] or [▼] to display "MAINTENANCE 80" on the LCD and press the [OK]. "MACERR\_01:\*\*\*\*" is displayed on the LCD (\*\*\*\* indicates error code).
- (2) Press the [Start] or [Mono Start], then the next item is displayed. Press the [▲] to go back to the previous item.
- (3) Press the [X] or [Stop], and the machine returns to the initial state of maintenance mode.

#### ■ Maintenance information

LCD	Description
MACERR_#:0000	Machine error log (last ten errors) *1
USB:000G8J000166	Serial number *2
MAC:008077112233	MAC address
PCB:911309123456	Main PCB serial number
KTN_ERM:87%	Amount of remaining toner estimated from coverage
KTN_RRM:67%	Amount of remaining toner estimated from the number of develop rotations
DRUM_PG:00000000	Printed pages for drum unit
PFMP_PG:00000000	Pages fed from PF kit MP (MP models only)
PFK1_PG:00000000	Pages fed from PF kit 1
FUSR_PG:00000000	Printed pages on fuser unit
LASR_PG:00000000	Printed pages on laser unit
TTL_PG:00000000	Total number of pages printed
DX_PG:00000000	Paper input for duplex tray
TTLCOPY:00000000	Total pages copied
DX_COPY:00000000	Total pages copied on both sides
TTLPCPT:00000000	Total number of pages printed via PC
DX_PCPT:00000000	Total number of two-sided pages printed via PC
TTLFAX:00000000	Total List / Fax pages printed (For models with FAX only)
DX_FAX:00000000	Total List / Fax pages printed on both sides (For models with FAX only)
TTL_OTH:00000000	Total number of pages printed by other methods
DX_OTH:00000000	Total number of two-sided pages printed by other methods
KCVRGUSI:4.32%*	Average coverage by the current toner cartridge
KCVRGACC:3.47%	Accumulated average coverage of toner cartridge
DRUM:00000000	Number of drum rotations
KTN_RND: 00000000	Number of develop roller rotations
TNSPL:0000000000	Supply amount of the toner box (Toner box models only)
MP_PG:00000000	Paper input for MP tray (MP models only)
MN_PG:00000000	Paper input for manual feed slot (Manual feed slot models only)
TR1_PG:00000000	Paper input for paper tray
DX_PG:00000000	Paper passed through duplex tray
A4+LTR:00000000	Total paper input for A4 and Letter
LG+FOL:00000000	Total paper input for Legal and Folio

LCD	Description
B5+EXE:00000000	Total paper input for B5 and Executive
ENVLOP:00000000	Paper input for Envelope
A5 :00000000	Paper input for A5 (including A5 Landscape)
OTHER :00000000	Paper input for other sizes
PLTNRE:00000000	Total printed pages of plain, thin, and recycled paper
TKTRBD:00000000	Total printed pages of thick, thicker, and bond paper
ENVTYP:00000000	Total printed pages of envelope, thick envelope, and thin envelope
LABEL:00000000	Printed pages on label
HAGAKI:00000000	Printed pages on postcard
TTL_JAM:00000000	Total paper jams that have occurred
MP_JAM:000000	Paper jams that have occurred in the MP tray (MP models only)
MN_JAM:00000000	Paper jams that have occurred in the manual feed slot (Manual feed slot models only)
TR1_JAM:00000000	Paper jams that have occurred in paper tray
IN_JAM:00000000	Paper jams that have occurred in the machine
RE_JAM:00000000	Paper jams that have occurred at the ejecting section or back cover
DX_JAM:00000000	Paper jams that have occurred in the duplex tray
POWER:00000375	Total power distribution time (unit: hour)
PWRCNT:00000001	Number of times that the power is turned ON
KTN_CH:0000	Number of times that the toner cartridge has been replaced <sup>*3</sup>
DRUM_CH:0000	Number of times that the drum unit has been replaced <sup>*3</sup>
KTN_PG1:00000000	Number of pages printed from the currently installed toner cartridge
KTN_PG2:00000000	Number of pages printed from the previous installed toner cartridge
SCN_PG:00000000	The number of scanned pages (except Fax and Copy)
ADTL_PG:00000000	Total pages of ADSX_PG and ADDX_PG
ADSX_PG:00000000	ADF single-side scanned pages
ADDX_PG:00000000	ADF double-side scanned pages
FB_PG:000000	Total FB scanned pages
ADSX_JAM:000000	Document jams that have occurred on ADF single-side scanning
ADDX_JAM:000000	Document jams that have occurred on ADF duplex scanning (duplex scanning models only)
FXTX_PG:00000000	The number of faxed pages
COMERR#:00000000	Communication error log (past three errors) <sup>*4</sup>
KDEV_BIAS:400V	Developing bias voltage value
ENGERR##:000000	Engine error log (last ten errors) <sup>*5</sup>
HODN_ER:0000	The number of discharge errors occurred
FUSR_ER:0000	The number of fuser unit errors occurred
MTLK_ER:0000	The number of polygon motor lock errors occurred in the laser scanner
DEVSTATUS ##:00	Log for design analysis <sup>*6</sup>
FUNC1:0000000000	SSW information 1 <sup>*7</sup>

<sup>\*1</sup> 01 to 10 will be displayed for “##” in chronological order. Pressing the [SET] or [OK] while the machine error log is displayed shows “PGCNT:00000000 (total pages printed at the time of the error)” on the LCD, and pressing the [SET] or [OK] again shows “TMP:000 HUM:000 (TMP: temperature at the time of the error (°C), HUM: humidity at the time of the error (%))” on the LCD.

\*2 Last 12 digits of the serial number are displayed.

The serial number can be changed according to the procedures below.

- 1) While the serial number is displayed, press the [9], [4], [7], and [5] in this order to enter the edit mode with the first digit flashing.

For models without keypad, press the [▲] or [▼] to display “9” on the LCD and press the [OK]. LCD displays the serial number again. Repeat the procedure to enter the [4], [7] and [5] in this order. Serial number is displayed on the LCD. The first digit starts flashing to indicate that it is editable.

- 2) Use the keypad to enter the first digit of the serial number. The second digit starts flashing. Enter the second digit to the 15th digit similarly.

<Entry method of alphanumeric characters>

See the table below and press the corresponding key until the desired character is displayed.

Keypad	Assigned characters
2	2→A→B→C
3	3→D→E→F
4	4→G→H→I
5	5→J→K→L
6	6→M→N→O
7	7→P→Q→R→S
8	8→T→U→V
9	9→W→X→Y→Z

**Note:**

For the initial products of touch panel models, if the character does not change in the left procedure, the character changes by pressing the [◀] followed by the [▶] or the [▶] followed by the [◀].

For models without keypad, press the [▲] or [▼] to display the first digit of the serial number on the LCD and press the [OK]. The second digit starts flashing. Enter the second digit to the 15th digit similarly.

- 3) Press the [SET] or [OK]. The serial number is saved and the machine returns to the initial state of maintenance mode.

\*3 Pressing the [SET] or [OK] while the number of each consumable part had replaced is displayed shows “DATE\_XX:000000” (XX: each consumable part) and the replaced date on the LCD.

\*4 Pressing the [SET] or [OK] while the communication error is displayed shows “DATE:0000000000” and the date of replacement on the LCD.

\*5 01 to 10 will be displayed for “##” in chronological order. Pressing the [SET] or [OK] while the engine error log is displayed shows “TM:00000 BT:000 (TM: the minutes passed from the previous error, BT: the number of times that the power is turned ON/OFF) on the LCD.

\*6 01 to 10 will be displayed for “##” in chronological order. Pressing the [SET] or [OK] while log for design analysis is displayed shows “PGCNT:00000000 (total pages printed at the time of the error)” on the LCD.

\*7 Pressing the [OK] while the SSW information 1 is displayed changes the display to the SSW information 2.

### 1.3.28 Display machine error code (Function code 82)

#### <Function>

This function is used to display the latest error code on the LCD.

#### <Operating Procedure>

- (1) Press the [8], and then the [2] in the initial state of maintenance mode. For models without keypad, press the [▲] or [▼] to display “MAINTENANCE 82” on the LCD and press the [OK]. “MACHINE ERR XXXX” is displayed on the LCD.
- (2) Press the [X] or [Stop], and the machine returns to the initial state of maintenance mode.

### **1.3.29 Send communication log information to telephone line (Function code 87)**

#### **<Function>**

This function is used to send the error list to service personnel at a remote service station when a fax communication problem has occurred in the user's machine. Receiving the error list allows the service personnel to analyze the problem current in the user's machine.

#### **<Operating Procedure>**

- Service side
- (1) Make a call from the service side equipment to the user side equipment.
- User side
- (2) Press the [8] and [7] in this order in the initial state of maintenance mode. "SENDING P.01" is displayed on the LCD and sending error list starts. When the error list is sent, the machine returns to the ready state.
- Service side
- (3) Once the user side equipment started sending the error list, press the [Start]. "Send or Receive? / 1.Send 2.Receive" is displayed on the LCD.
- (4) Press the [2]. Receiving the error list starts.

### **1.3.30 Reset irregular power supply detection counter of low-voltage power supply PCB (Function code 88)**

#### **<Function>**

This function is used to reset the corresponding counter after the low-voltage power supply PCB ASSY is replaced. The number of times the part has been replaced is increased by one.

#### **<Operating Procedure>**

- (1) Press the [8] twice in the initial state of maintenance mode. For models without keypad, press the [▲] or [▼] to display "MAINTENANCE 88" on the LCD and press the [OK]. "Reset- LVPS" is displayed on the LCD.
- (2) Press the [Start] or [Mono Start].
- (3) "Reset-LVPS OK?" is displayed on the LCD. Press the [Start] or [Mono Start] to reset the number of times that irregular power supply errors occurred and "Reset-LVPS" is displayed on the LCD.
- (4) Press the [X] or [Stop], and the machine returns to the initial state of maintenance mode.

### **1.3.31 Quit maintenance mode (Function code 99)**

#### **<Function>**

This function is used to quit the maintenance mode, restart the machine, and return it to the ready state. Also forcefully close the fuser unit error.

#### **<Operating Procedure>**

- (1) Press the [9] twice in the initial state of maintenance mode. For models without keypad, press the [▲] or [▼] to display "MAINTENANCE 99" on the LCD and press the [OK]. The machine quits the maintenance mode and returns to the ready state.

## 2. OTHER SERVICE FUNCTIONS

---

### 2.1 Drum Cleaning

**<Function>**

Attach the drum cleaning sheet kit (SP) (D011B4001) on the drum unit, and drum cleaning starts.

**<Operating Procedure>**

The insertion supplied with the drum cleaning sheet kit (SP) (D011B4001) is published on the next page.

**Note:**

The drum cleaning sheet is supposed to be used only one time.






## 2.2 Print Communication Error List

### <Function>

This function is used to print the communication error list (Communication List).

### <Operating Procedure>

#### For models with touch panel

- (1) Press and hold the  for approximately five seconds while the machine is in the ready state. The display shown on the right appears on the LCD.

1. Serial No	123456789012345
2. ROM Version	403071112:F97B

- (2) Press the blank field at the bottom on the LCD. The display shown on the right appears on the LCD.
- (3) Press the [#], [1], [0], [4], [1], and [4] in this order in two seconds.
- (4) Communication error list (Communication List) is printed. Press the [X], the machine returns to the ready state.

1	2	3	4	Stop	Mono Start
5	6	7	8	*	Color Start
<	9	0	SET	#	>

#### For models without touch panel

- (1) Press the [Menu], [#], [1], [0], [4], [1], and [4] in this order in approximately two seconds while the machine is in the ready state. Communication error list (Communication List) is printed. When printing is completed, the machine returns to the ready state.



## 2.3 Resetting Drum Counter

### <Function>

This function resets the drum counter when replacing it.

### <Operating Procedure>

#### Touch panel models

- (1) Close the front cover.
- (2) Press the .
- (3) Press and hold the  for five seconds.
- (4) Press the [Drum], and then press the [Yes].

#### Non-touch panel models

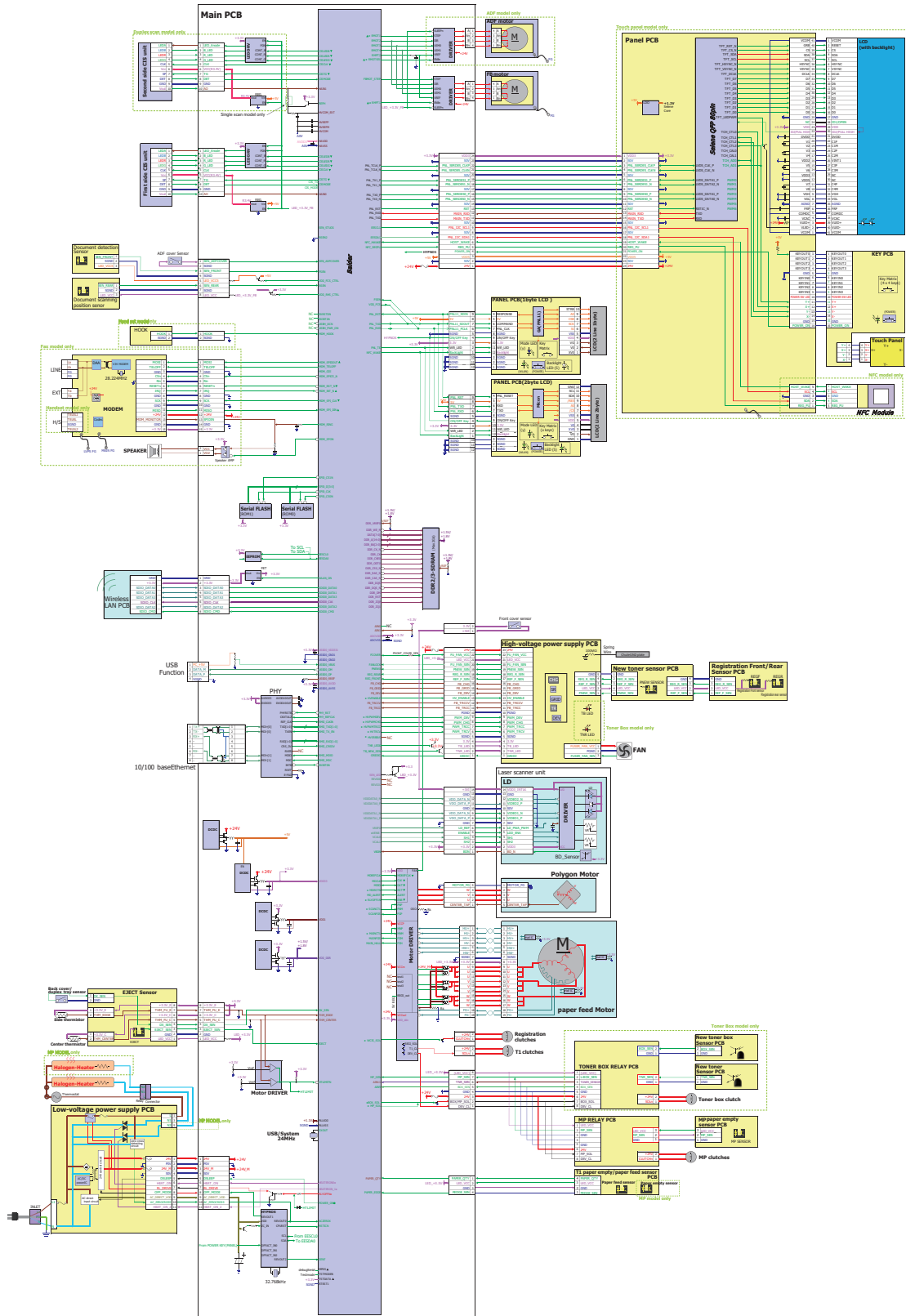
- (1) Close the front cover.
- (2) Press the [OK] and the [▲] at the same time.
- (3) Press the [OK] to select the "Drum".
- (4) Press the [▲] to reset the drum counter.

#### **Note:**

Resetting operation is ignored when the drum page count has not exceeded 100 pages.

# CHAPTER 6 WIRING DIAGRAM

## 1. WIRING DIAGRAM



---

# CHAPTER 7 PERIODICAL MAINTENANCE

---

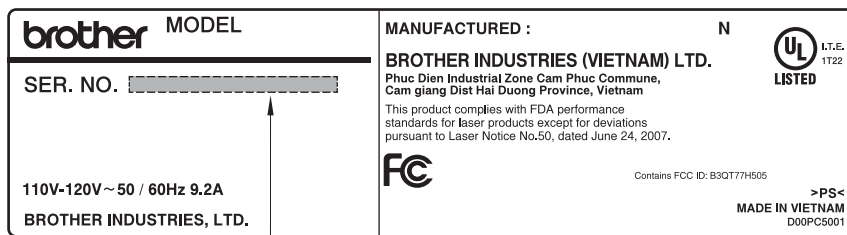
## 1. PERIODICAL REPLACEMENT PARTS

---

There are no parts to be replaced periodically.

# APPENDIX 1 SERIAL NUMBERING SYSTEM

## Serial number labels on the printer



Serial number



Fig. App 1-1

### <Location>

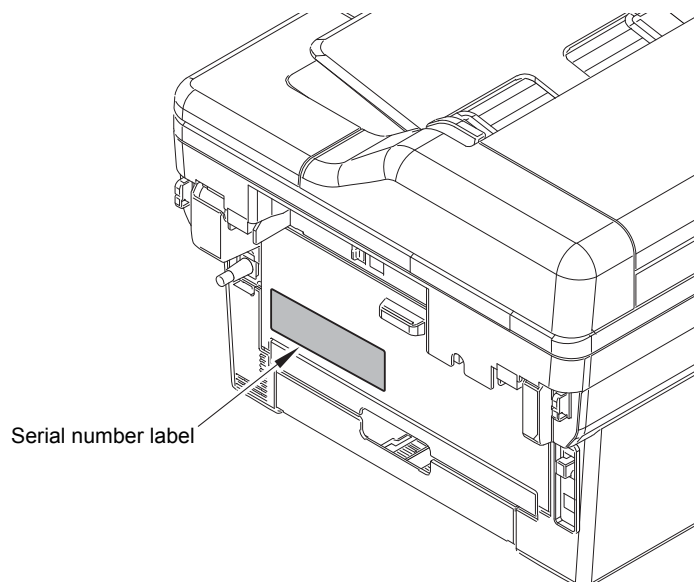


Fig. App 1-2

## APPENDIX 2 DELETING USER SETTING INFORMATION


The user setting information for the machine is stored in the main PCB. You can return this to the default settings by following the procedure below.

### <Operating Procedure>

#### For models without touch panel

- (1) Press the [Menu] while the machine is in the ready state.
- (2) Press the [▲] or [▼] to display “Initial Setup” on the LCD, and press the [OK].
- (3) Press the [▲] or [▼] to display “Reset” on the LCD, and press the [OK].
- (4) Press the [▲] or [▼] to display “Machine Reset” on the LCD, and press the [OK].  
“Machine Reset ▲Reset ▼Exit” appears on the LCD, and press the [▲].
- (5) “Reboot OK? ▲Yes ▼No” appears on the LCD. Press the [▲] to delete the user setting information and return the machine to the ready state.

#### For models with touch panel

- (1) Press the [Settings]  while the machine is in the ready state.
- (2) Press the [ALL Settings] on the LCD.
- (3) Press the [Initial Setup] on the LCD.
- (4) Press the [Reset] on the LCD.
- (5) Press the [Machine Reset] on the LCD.
- (6) “Factory Reset? It may take time until reset finishes. Yes No” appears on the LCD. Press the [Yes].
- (7) “Machine will reboot after resetting. Press [OK] for 2 seconds to confirm.” appears on the LCD. Press and hold the [OK] for 2 seconds or longer to delete the user setting information and return the machine to the ready state.

# APPENDIX 3 INSTALLING THE MAINTENANCE PRINTER DRIVER

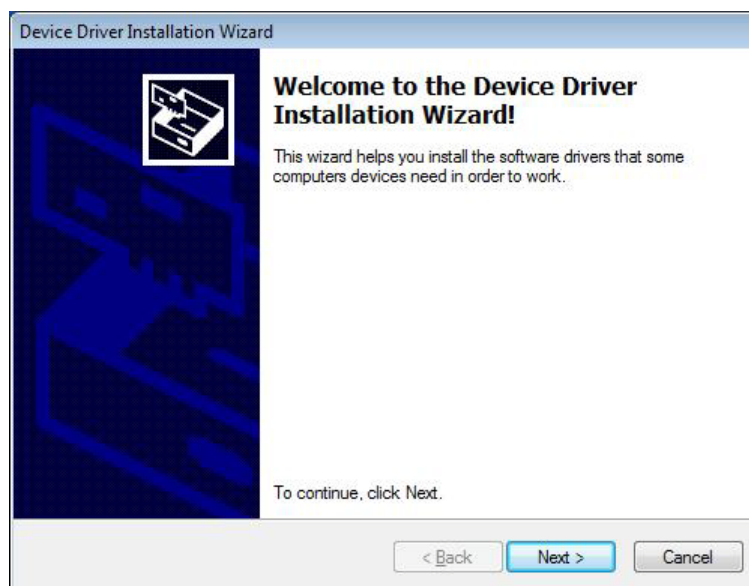
To identify machines connected via USB direct interface, the computer requires the corresponding driver for the virtual USB device. If you connect any number of machines to your computer, the same number of virtual USB devices will be automatically configured on your computer. To prevent many virtual USB devices from being configured, use the unique driver installation procedure described below that enables your computer to identify terminals via one single virtual USB device.

**Note:**

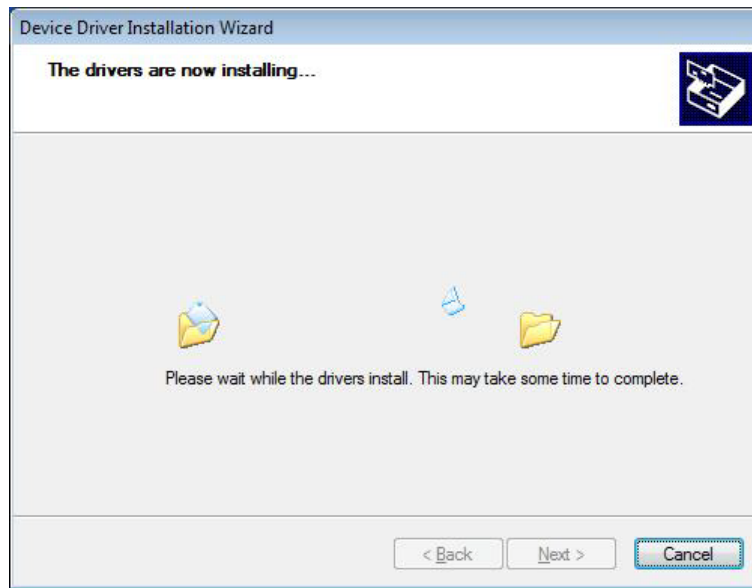
- Once this installation procedure is carried out for a computer, no more driver/software installation will be required for that computer to identify machines. If the Brother Maintenance USB Printer driver has been already installed to your computer according to this procedure, skip this section.
- Before proceeding to the procedure given below, make sure that the Brother Maintenance USB Printer driver is stored in your computer.

■ **Windows 7/Windows 8/Windows 8.1/Windows 10**

- (1) Check that the AC cord of the machine is unplugged from the electrical outlet. Disconnect the USB cable that connects the machine with your computer.
- (2) Turn ON your computer.
- (3) Double-click Setup.exe inside the Brother Maintenance USB Printer folder that was saved in a temporary folder. The following screen appears. Click the [Next] button.



The following screen is displayed during installation.



- (4) Wait for the following screen to appear and click [Finish].



- (5) Plug the AC cord of the machine into an electrical outlet.
- (6) Enter the maintenance mode.  
(Refer to "1.1 How to Enter Maintenance Mode" in Chapter 5.)
- (7) Connect the machine to your computer using a USB cable and the installation will be performed automatically.