

brother®

USER'S GUIDE

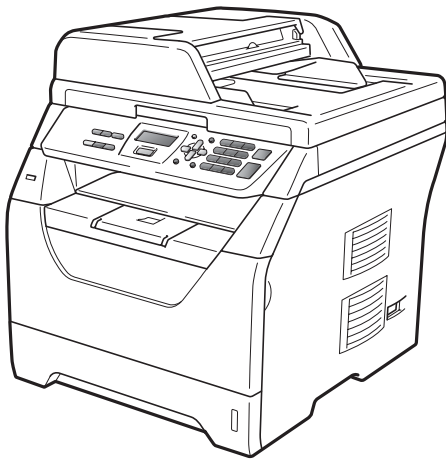

DCP-8070D

Version A

UK/IRE

If you need to call Customer Service

Please complete the following information for future reference:

Model Number: DCP-8070D

Serial Number: ¹ _____

Date of Purchase: _____

Place of Purchase: _____

¹ The serial number is on the back of the unit. Retain this User's Guide with your sales receipt as a permanent record of your purchase, in the event of theft, fire or warranty service.

Register your product on-line at

<http://www.brother.com/registration/>

By registering your product with Brother, you will be recorded as the original owner of the product. Your registration with Brother:

- may serve as confirmation of the purchase date of your product should you lose your receipt; and
- may support an insurance claim by you in the event of product loss covered by insurance

Compilation and Publication Notice

Under the supervision of Brother Industries Ltd., this manual has been compiled and published, covering the latest product descriptions and specifications.

The contents of this manual and the specifications of this product are subject to change without notice.

Brother reserves the right to make changes without notice in the specifications and materials contained herein and shall not be responsible for any damages (including consequential) caused by reliance on the materials presented, including but not limited to typographical and other errors relating to the publication.

Table of Contents

Section I General

1	General information	2
	Using the documentation	2
	Symbols and conventions used in the documentation	2
	Accessing the Software User's Guide	3
	Viewing documentation	3
	Accessing Brother Support (Windows®).....	5
	Control panel overview	6
	Data LED indications	8
2	Loading paper and documents	9
	Loading paper and print media	9
	Loading paper in the standard paper tray.....	9
	Loading paper in the multi-purpose tray (MP tray)	10
	Unprintable area	12
	Acceptable paper and other print media	13
	Recommended paper and print media	13
	Type and size of paper	13
	Handling and using special paper	15
	Loading documents	18
	Using the automatic document feeder (ADF)	18
	Using the scanner glass	19
3	General Setup	20
	Paper settings	20
	Paper Type	20
	Paper Size	20
	Tray Use in copy mode.....	21
	Tray Use in print mode	21
	Volume settings	22
	Beeper volume	22
	Ecology features	22
	Toner Save	22
	Sleep Time	22
	Automatic daylight savings time	23
	LCD Contrast	23
	User Settings List.....	23

Section II Copy

4	Making copies	26
	How to copy	26
	Entering copy mode.....	26
	Making a single copy	26
	Making multiple copies	26
	Stop copying.....	26
	Copy options (temporary settings).....	27
	Enlarging or reducing the image copied	27
	Using the Options key	28
	Improving copy quality.....	29
	Sorting copies using the ADF	29
	Adjusting Brightness and Contrast	29
	Making N in 1 copies (page layout)	30
	Tray selection	31
	Duplex (2-sided) copying	32
	Out of memory message	33

Section III Direct printing

5	Printing data from a USB Flash memory drive or a digital camera supporting mass storage	36
	Supported file formats.....	36
	Creating a PRN or PostScript® 3™ file for direct printing.....	36
	Printing data directly from the USB Flash memory drive or digital camera supporting mass storage	37
	Understanding the error messages	38

Section IV Software

6	Software features	40
	How to read the HTML User's Guide.....	40
	Windows®	40
	Macintosh	41

Section V Appendixes

A	Safety and legal	44
	Choosing a location	44
	To use the machine safely	45
	Important safety instructions	49
	Libtiff Copyright and License	51
	Trademarks	52
B	Options	53
	Memory board	53
	Installing extra memory	53
C	Troubleshooting and routine maintenance	55
	Troubleshooting	55
	If you are having difficulty with your machine	55
	Improving the print quality	59
	Error and maintenance messages	66
	Document jams	70
	Paper jams	71
	Routine maintenance	77
	Cleaning the outside of the machine	77
	Cleaning the scanner	78
	Cleaning the laser scanner window	79
	Cleaning the corona wire	81
	Cleaning the drum unit	82
	Replacing the consumable items	84
	Replacing a toner cartridge	85
	Replacing the drum unit	88
	Replacing periodic maintenance parts	90
	Machine Information	90
	Checking the Serial Number	90
	Checking the Page Counters	90
	Checking the remaining life of parts	90
	Reset	91
	Packing and shipping the machine	91
D	Menu and features	93
	On-screen programming	93
	Menu table	93
	Memory storage	93
	Menu keys	93
	How to access the menu mode	94
	Menu table	95
	Entering text	101

E	Specifications	102
	General	102
	Print media.....	104
	Copy	105
	Scan	106
	Print	107
	Interfaces	108
	Direct Print feature.....	108
	Computer requirements	109
	Consumable items	110
F	Glossary	111
G	Index	112



General

General information	2
Loading paper and documents	9
General Setup	20

1

General information

Using the documentation

Thank you for buying a Brother machine! Reading the documentation will help you make the most of your machine.

Symbols and conventions used in the documentation

The following symbols and conventions are used throughout the documentation.

Bold	Bold style identifies keys on the machine control panel or computer screen.
<i>Italics</i>	Italicized style emphasizes an important point or refers you to a related topic.
Courier New	Courier New font identifies the messages shown on the LCD of the machine.

WARNING

Warnings tell you what to do to prevent possible personal injury.

CAUTION

Cautions specify procedures you must follow or avoid to prevent possible minor injuries.

IMPORTANT

IMPORTANT describes procedures you must follow or avoid to prevent possible machine problems or damage to other objects.



Electrical Hazard icons alert you to a possible electrical shock.



Hot Surface icons warn you not to touch machine parts that are hot.



Notes tell you how you should respond to a situation that may arise or give tips about how the current operation works with other features.

Accessing the Software User's Guide

This User's Guide does not contain all the information about the machine such as how to use the advanced features of Printer and Scanner. When you are ready to learn detailed information about these operations, read the **Software User's Guide**.

Viewing documentation

Viewing documentation (Windows®)

To view the documentation, from the **Start** menu, point to **Brother, DCP-XXXX** (where XXXX is your model name) from the program group, and then click **User's Guides in HTML format**.

If you have not installed the software, you can find the documentation by following the instructions below:

- 1 Turn on your PC. Insert the Brother CD-ROM labelled Windows® into your CD-ROM drive.
- 2 If the language selection screen appears, click your language.
- 3 If the model name screen appears, click your model name. The CD-ROM main menu will appear.



If this window does not appear, use Windows® Explorer to find and run the Start.exe program from the root directory of the Brother CD-ROM.

- 4 Click **Documentation**.
- 5 Click the documentation you want to read:
 - HTML documents (2 manuals):
User's Guide for stand-alone operations and **Software User's Guide** in HTML format.

This format is recommended for viewing on your computer.
 - PDF documents (3 manuals):
User's Guide for stand-alone operations, **Software User's Guide** and **Quick Setup Guide**.

This format is recommended for printing the manuals. Click to go to the Brother Solutions Center, where you can view or download the PDF documents. (Internet access and PDF Reader software are required.)

How to find scanning instructions

There are several ways you can scan documents. You can find the instructions as follows:

Software User's Guide:

- Scanning a document using the TWAIN driver in Chapter 2
- Scanning a document using the WIA driver (Windows® XP/Windows Vista®) in Chapter 2
- Using ControlCenter3 in Chapter 3

ScanSoft™ PaperPort™ 11SE with OCR How-to-Guides:

- The complete ScanSoft™ PaperPort™ 11SE with OCR How-to-Guides can be viewed from the Help selection in the ScanSoft™ PaperPort™ 11SE application.

Viewing documentation (Macintosh)

- 1 Turn on your Macintosh. Insert the Brother CD-ROM labelled Macintosh into your CD-ROM drive.
- 2 The following window will appear.



- 3 Double-click the **Documentation** icon.
- 4 If the language selection screen appears, double-click your language.
- 5 Double-click the top page file to view the **User's Guide** for stand-alone operations and **Software User's Guide** in HTML format.
- 6 Click the documentation you want to read.
 - **User's Guide**
 - **Software User's Guide**



Note

The documents are also available in PDF format (3 manuals): **User's Guide** for stand-alone operations, **Software User's Guide** and **Quick Setup Guide**. The PDF format is recommended for printing the manuals.

Double-click **Brother Solutions Center** icon to go to the Brother Solutions Center, where you can view or download the PDF documents. (Internet access and PDF Reader software are required.)

How to find scanning instructions

There are several ways you can scan documents. You can find the instructions as follows:

Software User's Guide:

- Scanning in Chapter 9
- Using ControlCenter2 in Chapter 10

Presto! PageManager User's Guide:

- The complete Presto! PageManager User's Guide can be viewed from the Help selection in the Presto! PageManager application.

Accessing Brother Support (Windows®)

You can find all the contacts you will need, such as Web support (Brother Solutions Center).

- Click **Brother Support** on the main menu. The following screen will appear:



- To access our web site (<http://www.brother.com/>) click **Brother Home Page**.
- For the latest news and product support information (<http://solutions.brother.com/>), click **Brother Solutions Center**.
- To visit our web site for original/genuine Brother supplies (<http://www.brother.com/original/>), click **Supplies Information**.
- To return to the main page, click **Back** or if you have finished, click **Exit**.

Control panel overview

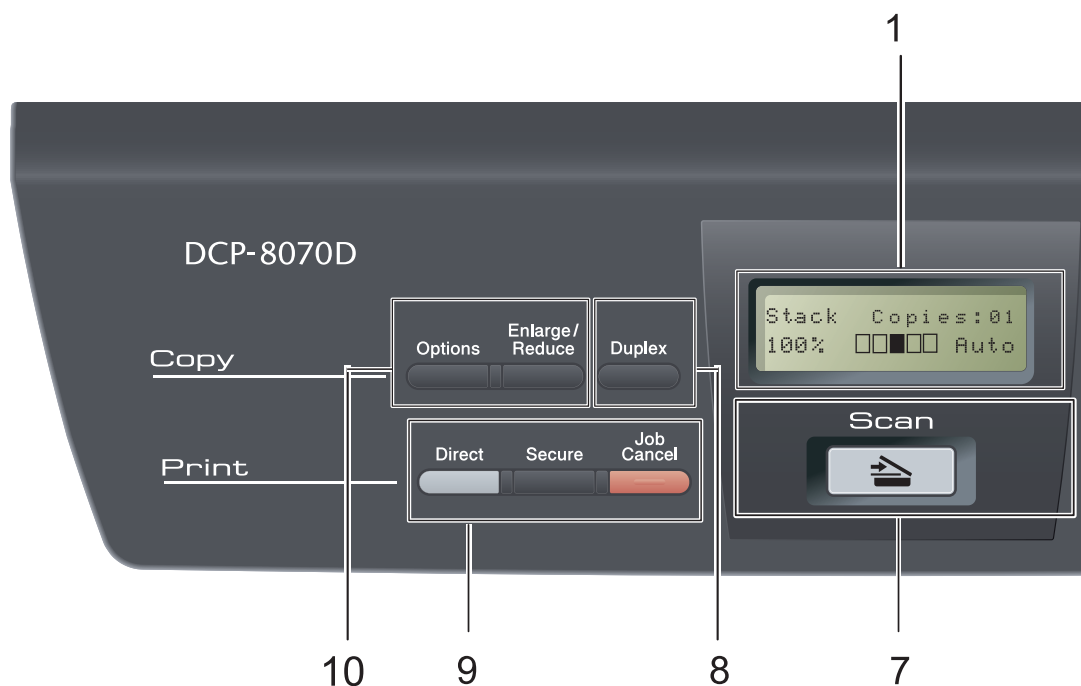

1 LCD

Displays messages to help you set up and use your machine.

2 Data LED

The LED will flash depending on the machine status.

3 Menu keys:

Menu

Lets you access the Menu to program your settings in this machine.

Clear/Back

Deletes entered data or lets you cancel the current setting.

OK

Lets you store your settings in the machine.

◀ or ▶

Press to scroll backwards or forwards through menu selections.

▲ or ▼

Press to scroll through the menus and options.

4 Numeric keys

Use these keys to enter text or numbers.

5 Stop/Exit

Stops an operation or exits from a menu.

6 Start

Lets you start making copies or scanning.

7 Scan

Puts the machine in Scan mode.

(For details about scanning, see the *Software User's Guide* on the CD-ROM.)

8 Duplex

You can choose Duplex to copy on both sides of the paper. (Print only)

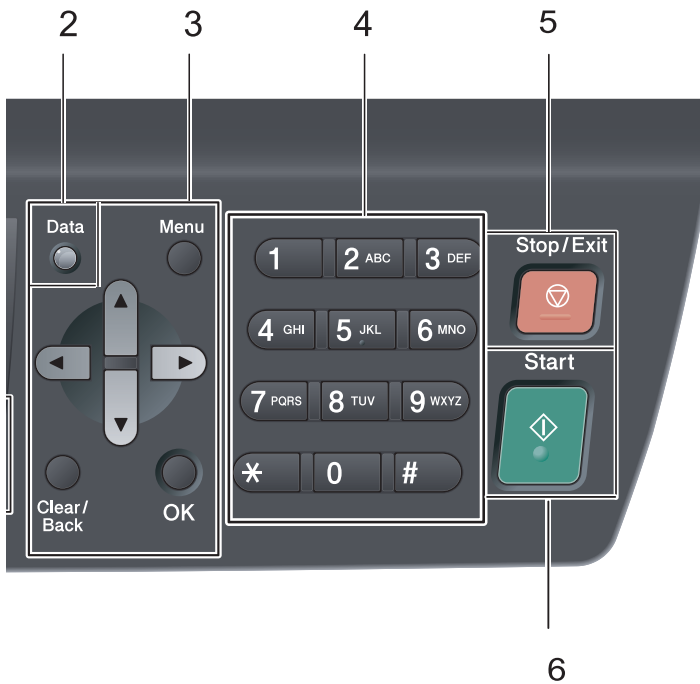

9 Print keys:

Direct

Lets you print data from a USB Flash memory drive connected directly to the machine. (See *Printing data directly from the USB Flash memory drive or digital camera supporting mass storage* on page 37.)

Secure

You can print data saved in memory when you enter your four-digit password. (For details about using the Secure key, see the *Software User's Guide* on the CD-ROM.)

Job Cancel

Cancels a programmed print job and clears it from the machine's memory.

To cancel multiple print jobs, hold down this key until the LCD shows
Job Cancel (All).

10 Copy keys:

Options

You can quickly and easily choose temporary settings for copying.



Enlarge/Reduce

Reduces or enlarges copies.

Data LED indications

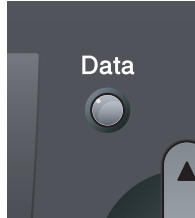
The **Data** LED (light emitting diode) will flash and turn on or off depending on the machine's status.



LED	LED Status	Machine Status	Description
	LED is off.	Ready Mode	The machine is ready to print, in sleep mode, there is no print data, or the power switch is off.
	LED is on.	Data remaining in Memory	Print data remains in the machine memory.
	LED is blinking.	Receiving Data	The machine is either receiving data from the computer, processing data in memory, or printing.

Loading paper and print media

The machine can feed paper from the standard paper tray or multi-purpose tray.

When you put paper into the paper tray, note the following:

- If your application software supports paper size selection on the print menu, you can select it through the software. If your application software does not support it, you can set the paper size in the printer driver or by using the control panel buttons.

Loading paper in the standard paper tray

Printing on plain paper, thin paper, bond paper, recycled paper or transparencies from the paper tray

- 1 Pull the paper tray completely out of the machine.

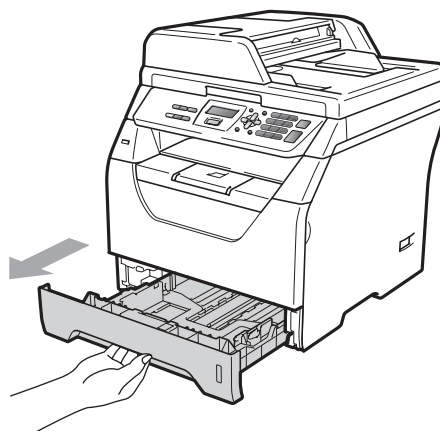

- 2 While pressing the blue paper-guide release lever (1), slide the paper guides to fit the paper size you are loading in the tray. Make sure that the guides are firmly in the slots.

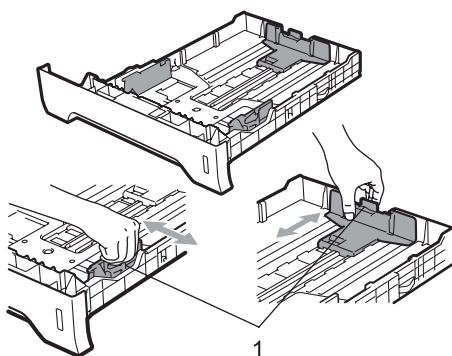

- 3 Fan the stack of paper well to avoid paper jams and misfeeds.

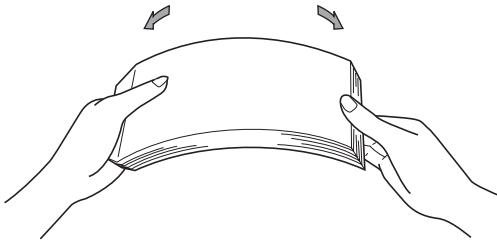

- 4 Put paper in the tray, and make sure that the paper is below the maximum paper mark (1). The side to be printed on must be face down.

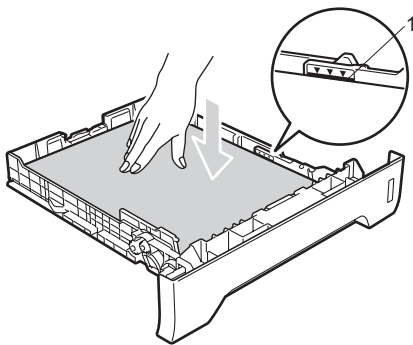

! IMPORTANT

Make sure the paper guides touch the sides of the paper so it will feed correctly.

- 5 Put the paper tray firmly back in the machine. Make sure that it is completely inserted into the machine.
- 6 Fold out the support flap (1) to prevent paper from sliding off the face-down output tray.

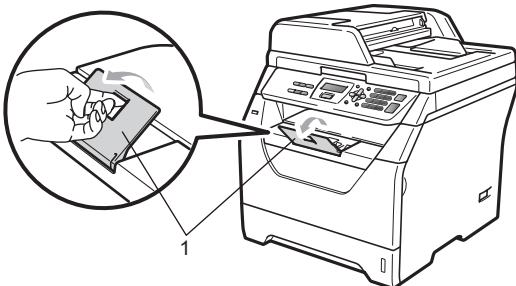

Loading paper in the multi-purpose tray (MP tray)

You can load up to 3 envelopes or special print media in the MP tray or up to 50 sheets of plain paper. Use this tray to print or copy on thick paper, bond paper, envelopes, labels or transparencies.

Printing on thick paper, bond paper, envelopes, labels and transparencies

Before loading, press the corners and sides of the envelopes to make them as flat as possible.

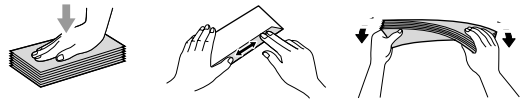

When the back output tray is pulled down, the machine has a straight paper path from the MP tray through to the back of the machine. Use this paper feed and output method when you want to print on thick paper, bond paper, envelopes, labels or transparencies.

! IMPORTANT

Remove each printed sheet or envelope immediately to prevent a paper jam.

- 1 Open the back cover (back output tray).

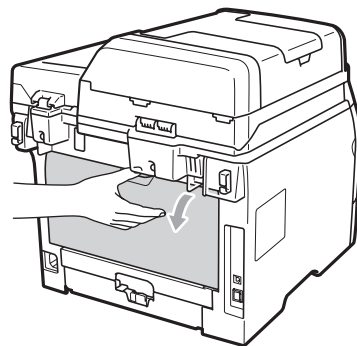

- 2 <For printing envelopes only>
Pull down the two blue levers, one on the left-hand side and one on the right-hand side, toward you as shown in the illustration below.

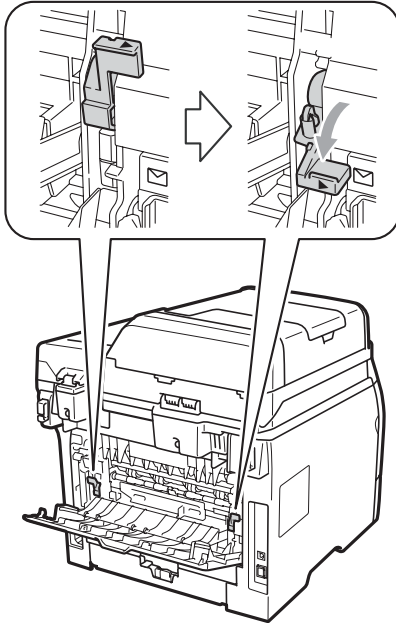

- 3 Open the MP tray and lower it gently.

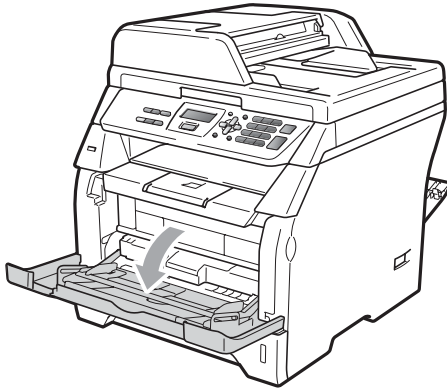

- 4 Pull out the MP tray support (1) and unfold the flap (2).

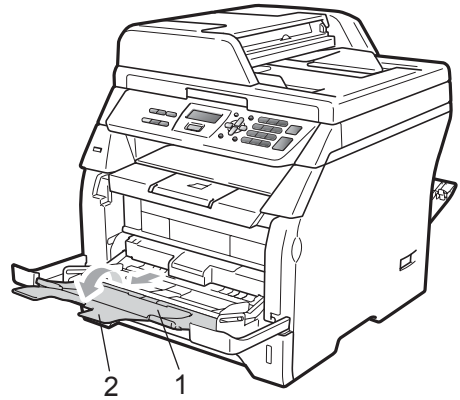

- 5 While pressing the paper side guide release lever, slide the paper guides to fit the width of the paper that you are going to use.

! IMPORTANT

Make sure the paper guides touch the sides of the paper so it will feed properly.

- 6 Put the envelopes (up to 3), thick paper, labels or transparencies in the MP tray with the top edge first and the print side face up. Make sure that the paper stays under the maximum paper mark (▼).

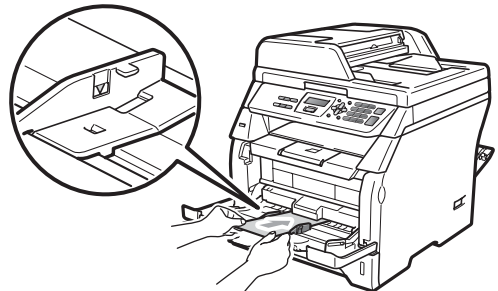

Unprintable area

Unprintable area for copies

The figures show unprintable areas.

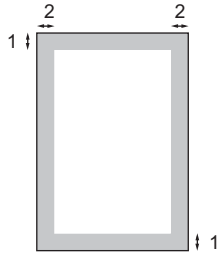

Document Size	Top (1) Bottom (1)	Left (2) Right (2)
A4	3 mm	2 mm
Letter	3 mm	4 mm



Note

This unprintable area shown above is for a single copy or a 1 in 1 copy using A4 size paper. The unprintable area changes with the paper size.

Unprintable area when printing from a computer

When using the printer driver the printable area is smaller than the paper size, as shown below.

Portrait

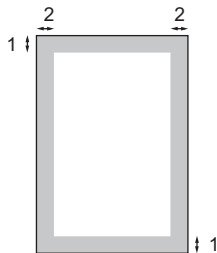

Landscape

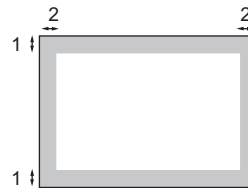

		Windows® printer driver and Macintosh printer driver	BRScript Driver for Windows® and Macintosh
Portrait	1	4.23 mm	4.23 mm
	2	6.35 mm	4.23 mm
Landscape	1	4.23 mm	4.23 mm
	2	5.08 mm	4.23 mm



Note

The unprintable area shown above is for A4 size paper. The unprintable area changes with the paper size.

Acceptable paper and other print media

Print quality may vary according to the type of paper you are using.

You can use the following types of print media: thin paper, plain paper, thick paper, bond paper, recycled paper, transparencies, labels or envelopes.

For best results, follow the instructions below:

- Use paper made for plain paper copying.
- Use paper that is 60 to 105 g/m².
- Use labels and transparencies which are designed for use in laser machines.
- DO NOT put different types of paper in the paper tray at the same time because it may cause paper jams or misfeeds.
- For correct printing, you must choose the same paper size from your software application as the paper in the tray.
- Avoid touching the printed surface of the paper immediately after printing.
- When you use transparencies remove each sheet immediately to prevent smudging or paper jams.
- Use long grain paper with a neutral Ph value, and a moisture content of approx. 5%.

Recommended paper and print media

To get the best print quality, we suggest using the following paper.

Paper Type	Item
Plain paper	Xerox Premier TCF 80 g/m ²
	Xerox Business 80 g/m ²
Recycled Paper	Xerox Recycled Supreme 80 g/m ²
Transparency	3M CG3300
Labels	Avery laser label L7163
Envelope	Antalis River series (DL)

Type and size of paper

The machine loads paper from the installed standard paper tray or multi-purpose tray.

Standard paper tray

Since the standard paper tray is a universal type, you can use any of the paper sizes (one paper type and size at a time) listed in the table in *Paper capacity of the paper trays* on page 14. The standard paper tray can hold up to 250 sheets of Letter/A4 size paper (80 g/m²). Paper can be loaded up to the maximum paper mark on the sliding paper width guide.

Multi-purpose tray (MP tray)

The MP tray can hold up to 50 sheets of plain paper (80 g/m²) or up to 3 envelopes. Paper can be loaded up to the maximum paper mark on the sliding paper width guide.

The name for the paper trays in the printer driver in this Guide are as follows:

Tray	Name
Standard paper tray	Tray 1
Multi-purpose tray	MP Tray

Paper capacity of the paper trays

	Paper size	Paper types	No. of sheets
Paper Tray (Tray #1)	A4, Letter, Executive, A5, A5 (Long Edge), A6, B5 and B6.	Plain paper, Thin paper, Bond paper and Recycled paper.	up to 250 [80 g/m ²]
		Transparency	up to 10
Multi-purpose tray (MP tray)	Width: 69.8 to 216 mm Length: 116 to 406.4 mm	Plain paper, Thin paper, Thick paper, Bond paper, Recycled paper, Envelopes and Labels.	up to 50 [80 g/m ²] up to 3 (envelopes)
		Transparency	up to 10

Recommended paper specifications

The following paper specifications are suitable for this machine.

Basis weight	75-90 g/m ²
Thickness	80-110 μm
Roughness	Higher than 20 sec.
Stiffness	90-150 cm ³ /100
Grain direction	Long grain
Volume resistivity	10e ⁹ -10e ¹¹ ohm
Surface resistivity	10e ⁹ -10e ¹² ohm-cm
Filler	CaCO ₃ (Neutral)
Ash content	Below 23 wt%
Brightness	Higher than 80%
Opacity	Higher than 85%

Handling and using special paper

The machine is designed to work well with most types of xerographic and bond paper. However, some paper variables may have an effect on print quality or handling reliability. Always test samples of paper before purchasing to ensure desirable performance. Store paper in its original packaging and keep it sealed. Keep the paper flat and away from moisture, direct sunlight and heat.

Some important guidelines when selecting paper are:

- Do not use inkjet paper because it may cause a paper jam or damage your machine.
- Preprinted paper must use ink that can withstand the temperature of the machine's fusing process (200 degrees centigrade).
- If you use bond paper, paper having a rough surface or paper that is wrinkled or creased, the paper may exhibit degraded performance.

Types of paper to avoid

! IMPORTANT

Some types of paper may not perform well or may cause damage to your machine.

DO NOT use paper:

- that is highly textured
- that is extremely smooth or shiny
- that is curled or warped

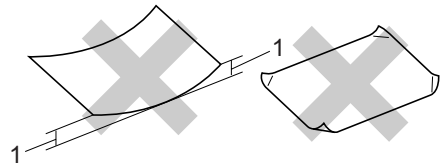

1 2mm or greater curl may cause jams to occur.

- that is coated or has a chemical finish
- that is damaged, creased or folded
- that exceeds the recommended weight specification in this guide
- with tabs and staples
- with letterheads using low temperature dyes or thermography
- that is multipart or carbonless
- that is designed for inkjet printing

If you use any of the types of paper listed above, they may damage your machine. This damage may not be covered under any Brother warranty or service agreement.

Envelopes

Most envelopes will be suitable for your machine. However, some envelopes may have feed and print-quality problems because of the way they have been made. A suitable envelope should have edges with straight, well-creased folds and the leading edge should not be thicker than two sheets of paper. The envelope should lie flat and not be of baggy or flimsy construction. You should buy quality envelopes from a supplier who understands that you will be using the envelopes in a laser machine.

Envelopes can only be fed from the MP tray. Do not print envelopes using duplex printing. We recommend that you print a test envelope to make sure the print results are what you want before you print or purchase a large quantity of envelopes.

Check the following:

- Envelopes should have a lengthwise sealing flap.
- The sealing flaps should be folded crisply and correctly (irregularly cut or folded envelopes may cause paper jams).
- Envelopes should consist of two layers of paper in the area circled in figure below.

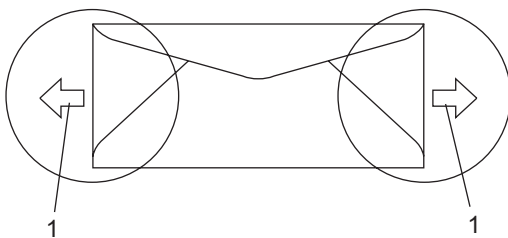

1 Feeding direction

- Envelope joints that are sealed by the manufacturer should be secure.
- We recommend that you do not print within 15 mm of the edges of envelopes.

Types of envelopes to avoid

! IMPORTANT

DO NOT use envelopes:

- that are damaged, curled, wrinkled or an unusual shape
- that are extremely shiny or textured
- with clasps, staples, snaps or tie strings
- with self-adhesive closures
- that are of a baggy construction
- that are not sharply creased
- that are embossed (have raised writing on them)
- that were previously printed by a laser machine
- that are pre-printed on the inside
- that cannot be arranged neatly when stacked
- that are made of paper that weighs more than the paper weight specifications for the machine
- with edges that are not straight or consistently square
- with windows, holes, cut-outs or perforations
- with glue on surface as shown in figure below

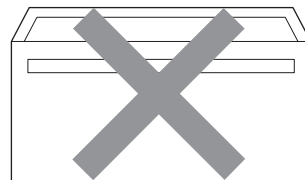

- with double flaps as shown in figure below

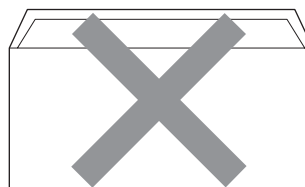

- with sealing flaps that have not been folded at purchase
- with sealing flaps as shown in figure below

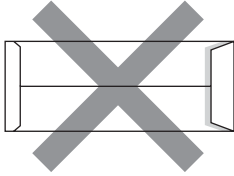

- with each side folded as shown in figure below

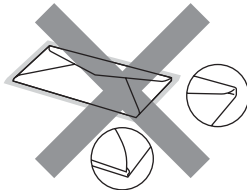

If you use any of the types of envelopes listed above, they may damage your machine. This damage may not be covered under any Brother warranty or service agreement.

Occasionally you may experience paper feed problems caused by the thickness, size and flap shape of the envelopes you are using.

Labels

The machine will print on most types of labels designed for use with a laser machine. Labels should have an adhesive that is acrylic-based since this material is more stable at the high temperatures in the fuser unit. Adhesives should not come in contact with any part of the machine, because the label stock may stick to the drum unit or rollers and cause jams and print quality problems. No adhesive should be exposed between the labels. Labels should be arranged so that they cover the entire length and width of the sheet. Using labels with spaces may result in labels peeling off and causing serious jams or print problems.

All labels used in this machine must be able to withstand a temperature of 392 degrees Fahrenheit (200 degrees centigrade) for a period of 0.1 seconds.

Label sheets should not exceed the paper weight specifications described in this User's Guide. Labels exceeding this specification may not feed or print correctly and may cause damage to your machine.

Labels can be fed from the MP Tray.

Types of labels to avoid

Do not use labels that are damaged, curled, wrinkled or an unusual shape.

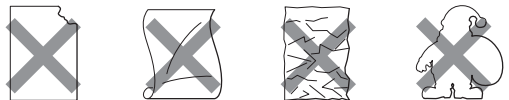

! IMPORTANT

DO NOT feed part used label sheets. The exposed carrier sheet will damage your machine.

Loading documents

Using the automatic document feeder (ADF)

The ADF can hold up to 20 pages of A4 sized paper and feeds each sheet individually. Use standard 80 g/m² paper and always fan the pages before putting them in the ADF.

Recommended environment

Temperature: 20 to 30° C
 Humidity: 50% - 70%
 Paper: Xerox Premier TCF 80 g/m² or Xerox Business 80 g/m²

! IMPORTANT

- DO NOT leave thick documents on the scanner glass. If you do this, the ADF may jam.
- DO NOT use paper that is curled, wrinkled, folded, ripped, stapled, paper-clipped, pasted or taped.
- DO NOT use cardboard, newspaper or fabric.
- To avoid damaging your machine while using the ADF, DO NOT pull on the document while it is feeding.



Note

To scan documents that are not suitable for the ADF, see *Using the scanner glass* on page 19.

- Make sure documents written with ink are completely dry.

- 1 Unfold the ADF output tray (1).



- 2 Fan the pages well.

- 3 Place your document **face down, top edge first** in the ADF until you feel it touch the feed roller.

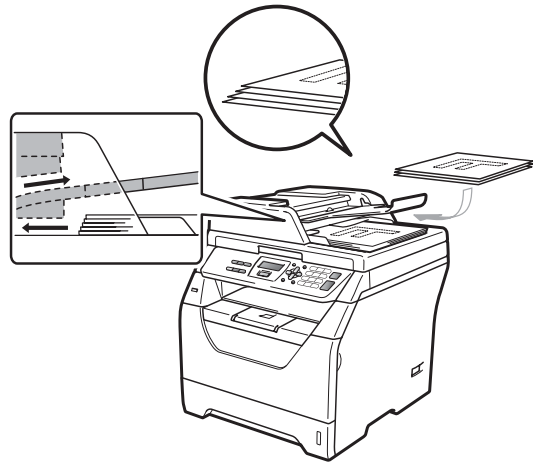

Note

Remove all printed documents from the ADF output tray before placing any new documents in the ADF.

- 4 Adjust the paper guides (1) to fit the width of your document.



Using the scanner glass

You can use the scanner glass to copy or scan pages of a book or one page at a time. Documents can be up to 215.9 mm wide and 297 mm long.



Note

To use the scanner glass, the ADF must be empty.

- 1 Lift the document cover.

- 2 Using the document guidelines on the left and top, place the document in the upper left hand corner with the document face down on the scanner glass.

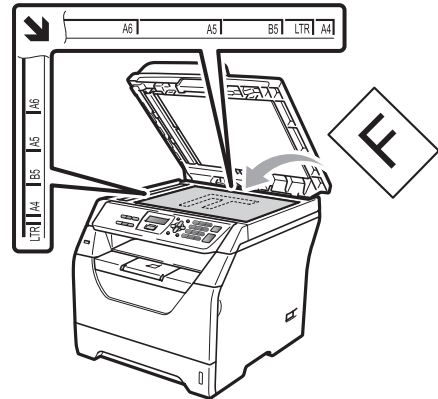

- 3 Close the document cover.

! IMPORTANT

If the document is a book or is thick do not slam the cover or press on it.

3

General Setup

Paper settings

Paper Type

Set up the machine for the type of paper you are using. This will give you the best print quality.

- 1 Do one of the following:
 - To set the paper type for the MP Tray press **Menu, 1, 1, 1, 1**.
 - To set the paper type for Tray#1 press **Menu, 1, 1, 1, 2**.
- 2 Press **▲** or **▼** to choose **Thin, Plain, Thick, Thicker, Transparency Or Recycled Paper**. Press **OK**.
- 3 Press **Stop/Exit**.

Paper Size

You can use several different sizes of paper for printing copies: A4, Letter, Legal, Executive, A5, A5 L, A6, B5, B6 and Folio.

When you change the size of paper in the tray, you will also need to change the setting for paper size at the same time so your machine can fit the document.

- 1 Do one of the following:
 - To set the paper size for the MP Tray press **Menu, 1, 1, 2, 1**.
 - To set the paper size for Tray#1 press **Menu, 1, 1, 2, 2**.
- 2 Press **▲** or **▼** to choose **A4, Letter, Legal, Executive, A5, A5 L, A6, B5, B6, Folio Or Any**. Press **OK**.
- 3 Press **Stop/Exit**.



Note

- **Legal, Folio and Any size** appears only when you choose the MP tray.
 - If you choose **Any** for the MP Tray Paper Size: You must choose **MP Only** for the Tray Use setting. You cannot use the **Any Paper Size** selection for the MP tray when making **N in 1** copies. You must choose one of the other available Paper Size selections for the MP tray.
 - If you chose **Transparency** for the Paper Type you will only be able to choose **Letter, Legal, Folio or A4** size paper in step 2.
-

Tray Use in copy mode

You can change the priority tray that the machine will use for printing copies.

When you choose **Tray#1 Only** or **MP Only**, the machine pulls the paper only from that tray. If the selected tray is out of paper, **No Paper** will appear on the LCD. Insert the paper in the empty tray.

To change the tray setting follow the instructions below:

- 1 Press **Menu, 1, 4, 1**.
- 2 Press **▲** or **▼** to choose **Tray#1 Only**, **MP Only**, **MP>T1** or **T1>MP**. Press **OK**.
- 3 Press **Stop/Exit**.



Note

- When loading the documents in the ADF and **MP>T1** or **T1>MP** is selected, the machine looks for the tray with the most suitable paper and pulls paper from that tray. If no tray has suitable paper, the machine pulls paper from the higher priority tray.
- When using the scanner glass, your document is copied from the higher priority tray even if more suitable paper is in another paper tray.

Tray Use in print mode

You can change the default tray the machine will use for printing from your computer.

- 1 Press **Menu, 1, 4, 2**.
- 2 Press **▲** or **▼** to choose **Tray#1 Only**, **MP Only**, **MP>T1** or **T1>MP**. Press **OK**.
- 3 Press **Stop/Exit**.



Note

- The setting in the printer driver will take priority over the setting made on the control panel.
- If the control panel is set to **Tray#1 Only** or **MP Only** and you choose **Auto Select** in the printer driver, the machine pulls the paper from that tray.

Volume settings

Beeper volume

When the beeper is on, the machine will beep when you press a key or make a mistake. You can choose a range of volume levels, from *High* to *Off*.

- 1 Press **Menu**, **1**, **2**.
- 2 Press **▲** or **▼** to choose *Off*, *Low*, *Med* or *High*. Press **OK**.
- 3 Press **Stop/Exit**.

Ecology features

Toner Save

You can save toner using this feature. When you set Toner Save to *On*, prints appear lighter. The default setting is *Off*.

- 1 Press **Menu**, **1**, **3**, **1**.
- 2 Press **▲** or **▼** to choose *On* or *Off*. Press **OK**.
- 3 Press **Stop/Exit**.



Note

We do not recommend Toner Save for printing Photo or Greyscale images.

Sleep Time

The Sleep Time setting can reduce power consumption by turning off the fuser while the machine is idle.

You can choose how long the machine must be idle before it goes into sleep mode. When the machine receives computer data or makes a copy, the timer will be reset. The default setting is 005 minutes.

While the machine is in sleep mode the LCD will display *Sleep*. When printing or copying in sleep mode, there will be a short delay while the fuser warms up.

- 1 Press **Menu**, **1**, **3**, **2**.
- 2 Enter the length of time the machine is idle before entering sleep mode. Press **OK**.
- 3 Press **Stop/Exit**.

Automatic daylight savings time

You can set the machine to change automatically for Daylight Savings Time. It will set itself forward one hour in the Spring, and back one hour in the Autumn.

- 1 Press **Menu**, **5**, **2**.
- 2 Press **▲** or **▼** to choose **On** or **Off**. Press **OK**.
- 3 Press **Stop/Exit**.

LCD Contrast

You can change the contrast to make the LCD look lighter or darker.

- 1 Press **Menu**, **1**, **5**.
- 2 Press **▼** to make the LCD lighter. Or, press **▲** to make the LCD darker. Press **OK**.
- 3 Press **Stop/Exit**.

User Settings List

You can print a list of the settings you programmed.

- 1 Press **Menu**, **5**, **5**.
- 2 Press **Start**.
- 3 Press **Stop/Exit**.



Copy

Making copies

26

4

Making copies

How to copy

Entering copy mode

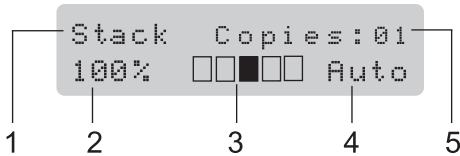

- 1 Stack/Sort/Duplex
- 2 Copy ratio and copy layout
- 3 Contrast
- 4 Quality
- 5 Number of copies

Making a single copy

- 1 Load your document.
- 2 Press **Start**.

Making multiple copies

- 1 Load your document.
- 2 Use the dial pad to enter the number of copies (up to 99).
- 3 Press **Start**.



Note

To sort your copies, see *Sorting copies using the ADF* on page 29.

Stop copying

To stop copying, press **Stop/Exit**.

Copy options (temporary settings)

When you want to quickly change the copy settings temporarily for the next copy, use the temporary **Copy** keys. You can use different combinations.



The machine returns to its default settings one minute after copying.

Enlarging or reducing the image copied

You can choose the following enlargement or reduction ratios:

Press 	100%*
	97% LTR→A4
	94% A4→LTR
	91% Full Page
	85% LTR→EXE
	83%
	78%
	70% A4→A5
	50%
	Custom (25-400%)
	Auto
	200%
	141% A5→A4
	104% EXE→LTR

* The factory setting is shown in Bold with an asterisk.

When set to *Auto*, the machine calculates the reduction ratio that best fits the paper size the paper tray is set to. (See *Paper Size* on page 20.)

Auto is only available when using the ADF.

Custom (25-400%) allows you to enter a ratio from 25% to 400%.

To enlarge or reduce the next copy follow the instructions below:

- 1 Load your document.
- 2 Use the dial pad to enter the number of copies (up to 99).
- 3 Press **Enlarge/Reduce**.
- 4 Do one of the following:
 - Press ▲ or ▼ to choose the enlargement or reduction ratio you want.
Press **OK**.
 - Press ▲ or ▼ to choose *Custom* (25-400%).
Press **OK**.

Use the dial pad to enter an enlargement or reduction ratio from 25% to 400%. (For example, press **5 3** to enter 53%.)
Press **OK**.
- 5 Press **Start**.





Note

Page Layout Options 2 in 1(P), 2 in 1(L), 4 in 1(P) or 4 in 1(L) are *not* available with Enlarge/Reduce.

Using the Options key

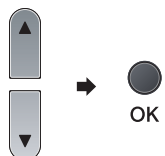
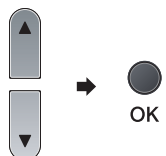
Use the **Options** key to quickly set the following copy settings temporarily for the next copy.

Press	Menu selections	Options	Page
Options 	Press ▲ or ▼, then press OK 	Press ▲ or ▼, then press OK 	
	Quality	Auto* Text Photo	29
	Stack/Sort (appears when the document is in the ADF)	Stack* Sort	29
	Brightness	▼-□□□■+▲ ▼-□□□■+▲ ▼-□□■□+▲* ▼-□■□□+▲ ▼-■□□□+▲	29
	Contrast	▼-□□□■+▲ ▼-□□□■+▲ ▼-□□■□+▲* ▼-□■□□+▲ ▼-■□□□+▲	30
	Page Layout	Off (1 in 1)* 2 in 1 (P) 2 in 1 (L) 4 in 1 (P) 4 in 1 (L)	30
	Tray Select	MP>T1* T1>MP #1 (XXX) ¹ MP (XXX) ¹ ¹ "XXX" is the paper size.	31
 The factory settings are shown in Bold with an asterisk.			

Improving copy quality

You can choose from a range of quality settings. The default setting is *Auto*.

■ Auto

Auto is the recommended mode for ordinary printouts. Suitable for documents that contain both text and photographs.

■ Text

Suitable for documents containing only text.

■ Photo

Suitable for copying photographs.

To *temporarily* change the quality setting, follow the steps below:

- 1 Load your document.
- 2 Use the dial pad to enter the number of copies (up to 99).
- 3 Press **Options**.
Press ▲ or ▼ to choose *Quality*.
Press **OK**.
- 4 Press ▲ or ▼ to choose *Auto*, *Text* or *Photo*.
Press **OK**.
- 5 Press **Start**.

To change the *default* setting, follow the steps below:

- 1 Press **Menu, 2, 1**.
- 2 Press ▲ or ▼ to choose the copy quality.
Press **OK**.
- 3 Press **Stop/Exit**.

Sorting copies using the ADF

You can sort multiple copies. Pages will be stacked in the order 1 2 3, 1 2 3, 1 2 3, and so on.

- 1 Unfold the ADF output tray and place your document *face down* in the ADF input tray.
- 2 Use the dial pad to enter the number of copies (up to 99).
- 3 Press **Options** and ▲ or ▼ to choose *Stack/Sort*.
Press **OK**.
- 4 Press ▲ or ▼ to choose *Sort*.
Press **OK**.
- 5 Press **Start**.

Adjusting Brightness and Contrast

Brightness

Adjust the copy brightness to make copies darker or lighter.

To *temporarily* change the copy brightness setting, follow the steps below:

- 1 Load your document.
- 2 Use the dial pad to enter the number of copies (up to 99).
- 3 Press **Options**.
Press ▲ or ▼ to choose *Brightness*.
Press **OK**.
- 4 Press ▲ to make a lighter copy or press ▼ to make a darker copy.
Press **OK**.
- 5 Press **Start**.

To change the *default* setting follow the steps below:

- 1 Press **Menu, 2, 2.**
- 2 Press **▲** to make a lighter copy or press **▼** to make a darker copy.
Press **OK.**
- 3 Press **Stop/Exit.**

Contrast

Adjust the contrast to help an image look sharper and more vivid.

To *temporarily* change the contrast setting, follow the steps below:

- 1 Load your document.
- 2 Use the dial pad to enter the number of copies (up to 99).
- 3 Press **Options.**
Press **▲** or **▼** to choose *Contrast.*
Press **OK.**
- 4 Press **▲** or **▼** to increase or decrease the contrast.
Press **OK.**
- 5 Press **Start.**

To change the *default* setting follow the steps below:

- 1 Press **Menu, 2, 3.**
- 2 Press **▲** or **▼** to increase or decrease the contrast.
Press **OK.**
- 3 Press **Stop/Exit.**

Making N in 1 copies (page layout)

You can reduce the amount of paper used when copying by using the N in 1 copy feature. This allows you to copy two or four pages onto one page, which lets you save paper.

! IMPORTANT

- Please make sure the paper size is set to Letter, A4, Legal ¹ or Folio ¹.
- (P) means Portrait and (L) means Landscape.
- You cannot use the Enlarge/Reduce setting with the N in 1 feature.

¹ You can choose Legal and Folio for MP Tray only.

- 1 Load your document.
- 2 Use the dial pad to enter the number of copies (up to 99).
- 3 Press **Options.**
Press **▲** or **▼** to choose *Page Layout.*
Press **OK.**
- 4 Press **▲** or **▼** to choose 2 in 1 (P), 2 in 1 (L), 4 in 1 (P), 4 in 1 (L) or Off (1 in 1).
Press **OK.**
- 5 Press **Start** to scan the page.
If you placed the document in the ADF, the machine scans the pages and starts printing.
If you are using the scanner glass, go to step 6.
- 6 After the machine scans the page, press **1** to scan the next page.

Next Page?
1.Yes 2.No

- 7 Put the next page on the scanner glass. Press **OK**. Repeat steps 6 and 7 for each page of the layout.
- 8 After all the pages have been scanned, press 2 in step 6 to finish.

Place the document face down in the direction shown below:

■ 2 in 1 (P)

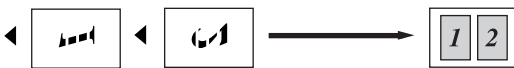

■ 2 in 1 (L)

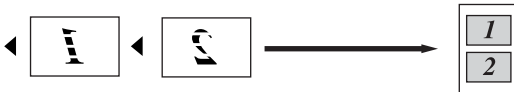

■ 4 in 1 (P)



■ 4 in 1 (L)



Tray selection

You can change the Tray Use only for the next copy.

- 1 Load your document.
- 2 Use the dial pad to enter the number of copies (up to 99).
- 3 Press **Options**. Press **▲** or **▼** to choose Tray Select. Press **OK**.
- 4 Press **▲** or **▼** to choose the MP>T1, T1>MP, #1 (XXX) or MP (XXX). Press **OK**.
- 5 Press **Start**.



Note

To change the default setting for Tray Select, see *Tray Use in copy mode* on page 21.

Duplex (2-sided) copying

If you want to use the duplex copy feature, load your document in the ADF.

If you get an *Out of Memory* message while you are making duplex copies, try installing extra memory. (See *Out of memory message* on page 33.)

Duplex Copy (long edge flip)

■ 1sided-2sided L

Portrait

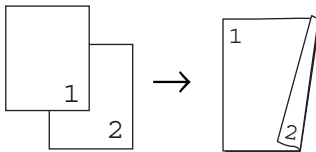

Landscape

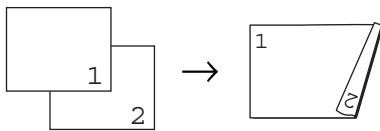

- 1 Unfold the ADF output tray and place your document *face down* in the ADF input tray.
- 2 Enter the number of copies (up to 99) using the dial pad.
- 3 Press **Duplex** and ▲ or ▼ to choose 1sided-2sided L. Press **OK**.
- 4 Press **Start** to copy the document.

Advanced Duplex Copy (short edge flip)

■ 1sided-2sided S

Portrait

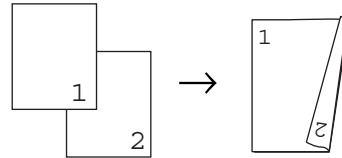

Landscape

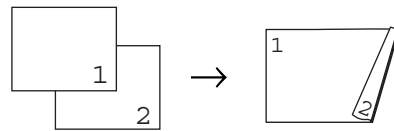

- 1 Unfold the ADF output tray and place your document *face down* in the ADF input tray.
- 2 Enter the number of copies (up to 99) using the dial pad.
- 3 Press **Duplex** and ▲ or ▼ to choose 1sided-2sided S. Press **OK**.
- 4 Press **Start** to copy the document.



Note

(L) means Long edge and (S) means Short edge.

Out of memory message

If the memory becomes full while you are making copies, the LCD message will guide you through the next step.

If you get an `Out of Memory` message while scanning a subsequent page, you will have the option to press **Start** to copy the pages scanned so far, or to press **Stop/Exit** to cancel the operation.



Direct printing

**Printing data from a USB Flash memory drive
or a digital camera supporting mass storage 36**

5

Printing data from a USB Flash memory drive or a digital camera supporting mass storage

With the Direct Print feature, you do not need a computer to print data. You can print by just plugging your USB Flash memory drive into the machine's USB direct interface. You can also connect and print directly from a camera set to USB mass storage mode.

Note

- Some USB Flash memory drives may not work with the machine.
- If your camera is in PictBridge mode, you cannot print data. Please refer to the documentation supplied with your camera to switch from PictBridge mode to mass storage mode.

Supported file formats

Direct Print supports the following file formats:

- PDF version 1.7 ¹
- JPEG
- Exif + JPEG
- PRN (created by Brother driver)
- TIFF (scanned by all MFC or DCP Brother models)
- PostScript® 3™ (created by the Brother BRScript3 printer driver)
- XPS version 1.0

¹ PDF data including a JBIG2 image file, a JPEG2000 image file or transparency files are not supported.

Creating a PRN or PostScript® 3™ file for direct printing

Note

The screens in this section may vary depending on your application and operating system.

- 1 From the menu bar of an application, click **File**, then **Print**.
- 2 Choose **Brother DCP-XXXX Printer** (1) and check the **Print to file** box (2). Click **Print**.

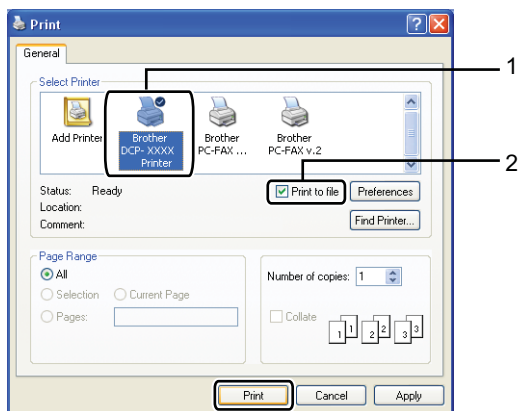

- 3 Choose the folder you want to save the file to and enter the file name if you are prompted to.
If you are prompted for a file name only, you can also specify the folder you want to save the file in by entering the directory name. For example:
C:\Temp\FileName.prn
If you have a USB Flash memory drive or digital camera connected to your computer, you can save the file directly to the USB Flash memory drive.

Printing data directly from the USB Flash memory drive or digital camera supporting mass storage

- 1 Connect your USB Flash memory drive or digital camera to the USB direct interface (1) on the front of the machine.

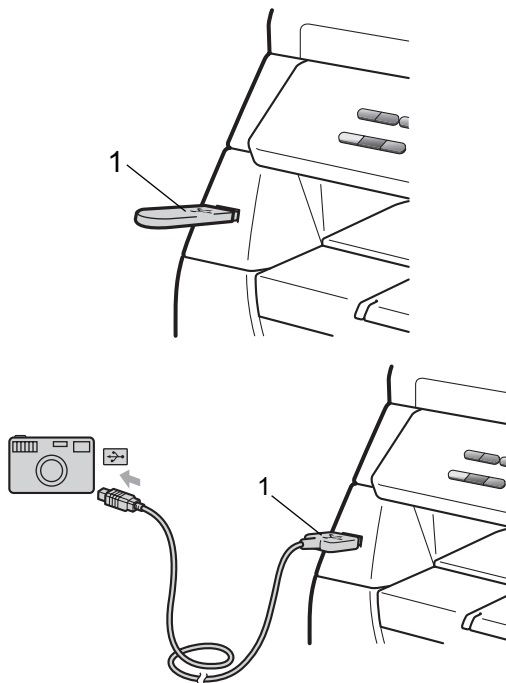

- 2 When the machine has recognized the USB flash memory drive or digital camera, the **Direct** key turns blue. Press the **Direct** key.
- 3 Press **▲** or **▼** to choose the folder name or file name you want to print. Press **OK**. If you have chosen the folder name, press **▲** or **▼** to choose the file name you want to print. Press **OK**.

Note

- Your digital camera must be switched from PictBridge mode to mass storage mode.
- If you want to print an index of the files, choose **Index Print**, and then press **OK**. Press **Start** to print the data.
- File names that are stored in your USB Flash memory drive can be displayed using the following characters on the LCD:
A B C D E F G H I J K L M N O P Q R S T
U V W X Y Z 0 1 2 3 4 5 6 7 8 9 \$ % ' ` - @
{ } ~ ! # () & _ ^

- 4 Do one of the following:

- Press **▲** or **▼** to choose a setting you need to change and press **OK**, and then press **▲** or **▼** to choose an option for the setting and press **OK**.
- If you do not need to change the current default settings, go to step 5.

Print File Set
Paper Size

Note

- You can choose the following settings:
Paper Size
Media Type
Multiple Page
Orientation
Duplex
Collate
Tray Use
Print Quality
PDF Option
- Depending on the file type, some of these settings may not appear.

- 5 Press **Start** if you have finished.

- 6 Press the dial pad key to enter the number of copies you want. Press **OK**.
- 7 Press **Start** to print the data.

IMPORTANT

- To prevent damage to your machine, **DO NOT** connect any device other than a digital camera or USB Flash memory drive to the USB direct interface.
- **DO NOT** remove the USB Flash memory drive or digital camera from the USB direct interface until the machine has finished printing.



Note

- If you want to change the default setting for the paper tray to feed paper from, press **Menu, 1, 4, 2** to change the paper tray setting.
- You can change the default settings for Direct Print by using the control panel when the machine is not in the Direct Print mode. Press **Menu, 4** to enter the USB Direct I/F menu. (See *Menu table* on page 95.)

Understanding the error messages

Once you are familiar with the types of errors that can occur while you print data from the USB Flash memory drive or digital camera with Direct Print, you can easily identify and troubleshoot any problems.

■ Out of Memory

This message will appear if you are working with images that are too large for the machine's memory.

■ Unusable Device

This message will appear if you connect an incompatible or broken device to the USB direct interface. To clear the error, unplug the device from the USB direct interface.

(See *Error and maintenance messages* on page 66 for the detailed solution.)



Software

Software features

40

6

Software features

The HTML User's Guide on the CD-ROM includes the **User's Guide** and **Software User's Guide** for features available when connected to a computer (for example, printing and scanning). These guides have easy to use links that, when clicked, will take you directly to a particular section.

You can find information on these features:

- Printing
- Scanning
- ControlCenter3 (Windows®)
- ControlCenter2 (Macintosh)



Note

See *Accessing the Software User's Guide* on page 3.

How to read the HTML User's Guide

This is a quick reference for using the HTML User's Guide.

Windows®



Note

If you have not installed the software, see *Viewing documentation (Windows®)* on page 3.

- 1 From the **Start** menu, point to **Brother**, **DCP-XXXX** from the programs group, then click **User's Guides in HTML format**.
- 2 Click on the manual you want (**USER'S GUIDE** or **SOFTWARE USER'S GUIDE**) from the Top Menu.

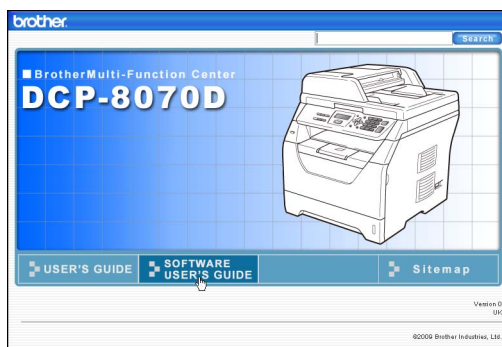

- 3 Click the heading you would like to view from the list at the left of the window.

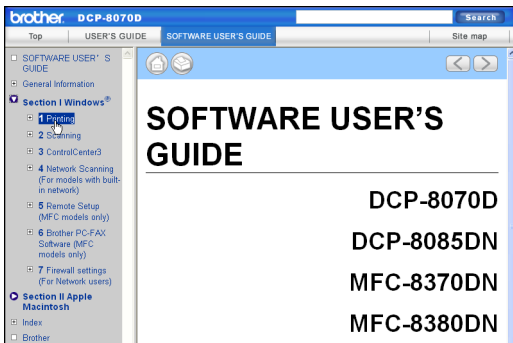

Macintosh

- 1 Make sure your Macintosh is turned on. Insert the Brother CD-ROM into your CD-ROM drive.
- 2 Double-click the **Documentation** icon.
- 3 Double-click your language folder, and then double-click the top.html file.
- 4 Click on the manual you want (**USER'S GUIDE** or **SOFTWARE USER'S GUIDE**) in the top menu, and then click the heading you would like to read from the list at the left of the window.

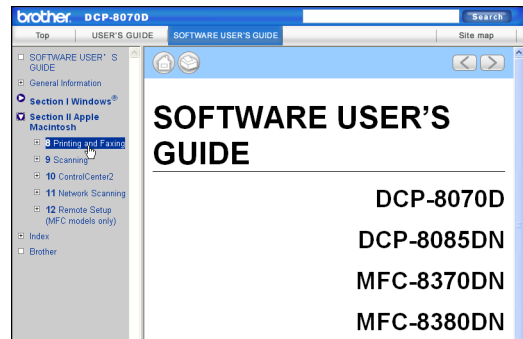



Appendixes

Safety and legal	44
Options	53
Troubleshooting and routine maintenance	55
Menu and features	93
Specifications	102
Glossary	111

A

Safety and legal

Choosing a location

Put your machine on a flat, stable surface that is free of vibration and shocks, such as a desk. Put the machine near a standard grounded electrical socket. Choose a location where the temperature remains between 10°C and 32.5°C and the humidity is between 20% to 80% (without condensation.)

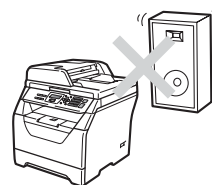
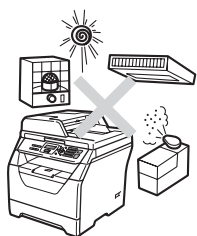

⚠ WARNING

DO NOT expose the machine to direct sunlight, excessive heat, open flames, salty or corrosive gasses, moisture or dust.

DO NOT place the machine near heaters, air conditioners, refrigerators, water or chemicals.

⚠ CAUTION

Avoid placing your machine in a high-traffic area.

Avoid placing your machine on a carpet.

DO NOT connect your machine to electrical sockets controlled by wall switches or automatic timers, or to the same circuit as large appliances that might disrupt the power supply.

Disruption of power can wipe out information in the machine's memory.

Make sure cables leading to the machine do not constitute a trip hazard.

To use the machine safely

Please keep these instructions for later reference and read them before attempting any maintenance.

WARNING



There are high voltage electrodes inside the machine. Before you clean the inside of the machine, make sure you have unplugged the power cord from the electrical socket. Doing this will prevent an electrical shock.

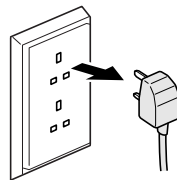

DO NOT handle the plug with wet hands. Doing this might cause an electrical shock. Always make sure the plug is fully inserted.

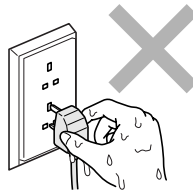

This product must be installed near an electrical socket that is easily accessible. In case of an emergency, you must unplug the power cord from the electrical socket to shut off the power completely.

Plastic bags are used in the packing of your machine and drum unit. To avoid the danger of suffocation, keep these bags away from babies and children.

DO NOT use flammable substances, any type of spray or any organic solvent/liquids contains alcohol or ammonia to clean the inside or outside of the machine. Doing this may cause a fire or electrical shock. See *Routine maintenance* on page 77 for how to clean the machine.



DO NOT use a vacuum cleaner to clean up scattered toner. Doing this might cause the toner dust to ignite inside the vacuum cleaner, potentially starting a fire. Please carefully clean the toner dust with a dry, lint-free soft cloth and dispose of it according to local regulations.

CAUTION



After you have just used the machine, some internal parts of the machine will be extremely hot. When you open the front or back cover of the machine, DO NOT touch the shaded parts shown in the illustrations.

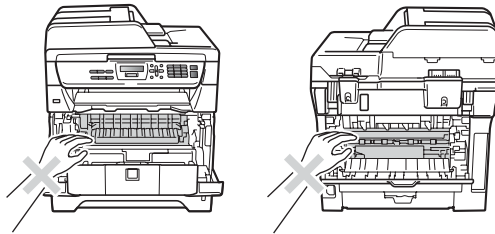

To prevent injuries, be careful not to put your hands on the edge of the machine under the scanner or document cover as shown in the illustrations.

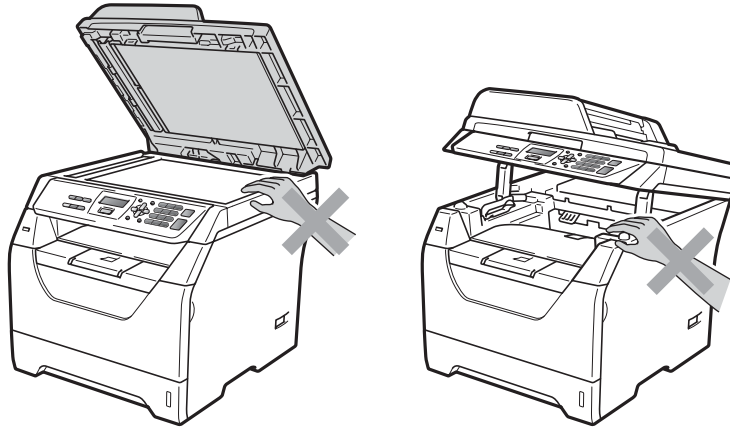

To prevent injuries, be careful not to put your fingers in the area shown in the illustration.

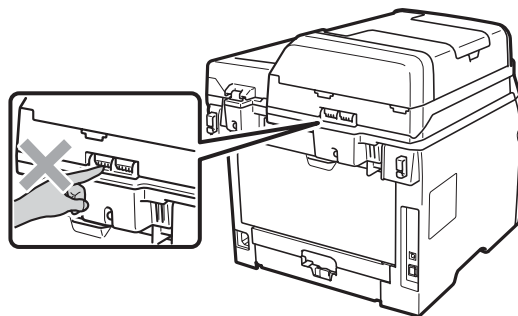

When you move the machine, grasp the side hand holds that are located at the bottom of the machine.

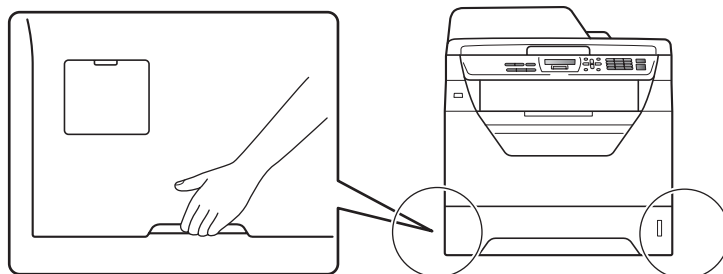

! IMPORTANT

The fuser unit is marked with a Caution label. Please DO NOT remove or damage the label.

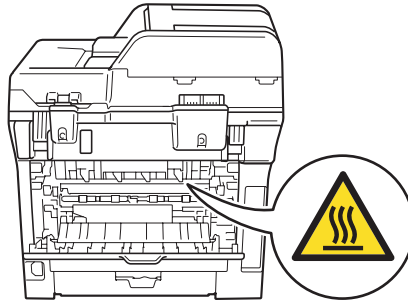

Important safety instructions

- 1 Read all of these instructions.
- 2 Save them for later reference.
- 3 Follow all warnings and instructions marked on the product.
- 4 Unplug this product from the wall socket before cleaning inside of the machine. **DO NOT** use liquid or aerosol cleaners. Use a dry lint-free soft cloth for cleaning.
- 5 **DO NOT** place this product on an unstable cart, stand, or table. The product may fall, causing serious damage to the product.
- 6 Slots and openings in the casing at the back or bottom are provided for ventilation. To ensure reliable operation of the product and to protect it from overheating, these openings must not be blocked or covered. The openings should never be blocked by placing the product on a bed, sofa, rug, or other similar surface. This product should never be placed near or over a radiator or heater. This product should never be placed in a built-in installation unless adequate ventilation is provided.
- 7 This product should be connected to an AC power source within the range indicated on the rating label. **DO NOT** connect it to a DC power source or inverter. If you are not sure, contact a qualified electrician.
- 8 This product is equipped with a 3-wire grounded plug. This plug will only fit into a grounded power outlet. This is a safety feature. If you are unable to insert the plug into the outlet, call your electrician to replace your obsolete outlet. **DO NOT** defeat the purpose of the grounded plug.
- 9 Use only the power cord supplied with this machine.
- 10 **DO NOT** allow anything to rest on the power cord. **DO NOT** place this product where people can walk on the cord.
- 11 Use the product in a well-ventilated area.
- 12 The power cord, including extensions, should be no longer than 5 metres.

DO NOT share the same power circuit with other high powered appliances, such as an air conditioner, copier, shredder, and so on. If you cannot avoid using the printer with these appliances, we recommend that you use a voltage transformer or a high-frequency noise filter.

Use a voltage regulator if the power source is not stable.
- 13 **DO NOT** place anything in front of the machine that will block printed pages. **DO NOT** place anything in the path of printed pages.
- 14 Wait until pages have exited the machine before picking them up.

15 Unplug this product from the power socket and refer all servicing to Brother Authorized Service Personnel under the following conditions:

- When the power cord is damaged or frayed.
- If liquid has been spilled into the product.
- If the product has been exposed to rain or water.
- If the product does not operate normally when the operating instructions are followed. Adjust only those controls that are covered by the operating instructions. Incorrect adjustment of other controls may result in damage and will often require extensive work by a qualified technician to restore the product to normal operation.
- If the product has been dropped or the casing has been damaged.
- If the product exhibits a distinct change in performance, indicating a need for service.

16 To protect your product against power surges, we recommend the use of a power protection device (Surge Protector).

17 To reduce the risk of fire, electric shock and injury to people, note the following:

- DO NOT use this product near appliances that use water, a swimming pool or in a wet basement.
- DO NOT use the machine during an electrical storm (there is the remote possibility of an electrical shock).
- DO NOT use this product in the vicinity of a gas leak.

Libtiff Copyright and License

Use and Copyright

Copyright© 1988-1997 Sam Leffler

Copyright© 1991-1997 Silicon Graphics, Inc.

Permission to use, copy, modify, distribute, and sell this software and its documentation for any purpose is hereby granted without fee, provided that (i) the above copyright notices and this permission notice appear in all copies of the software and related documentation, and (ii) the names of Sam Leffler and Silicon Graphics may not be used in any advertising or publicity relating to the software without the specific, prior written permission of Sam Leffler and Silicon Graphics.

THE SOFTWARE IS PROVIDED "AS-IS" AND WITHOUT WARRANTY OF ANY KIND, EXPRESS, IMPLIED OR OTHERWISE, INCLUDING WITHOUT LIMITATION, ANY WARRANTY OF MERCHANTABILITY OR FITNESS FOR A PARTICULAR PURPOSE.

IN NO EVENT SHALL SAM LEFFLER OR SILICON GRAPHICS BE LIABLE FOR ANY SPECIAL, INCIDENTAL, INDIRECT OR CONSEQUENTIAL DAMAGES OF ANY KIND, OR ANY DAMAGES WHATSOEVER RESULTING FROM LOSS OF USE, DATA OR PROFITS, WHETHER OR NOT ADVISED OF THE POSSIBILITY OF DAMAGE, AND ON ANY THEORY OF LIABILITY, ARISING OUT OF OR IN CONNECTION WITH THE USE OR PERFORMANCE OF THIS SOFTWARE.

A

Trademarks

The Brother logo is a registered trademark of Brother Industries, Ltd.

Brother is a registered trademark of Brother Industries, Ltd.

Multi-Function Link is a registered trademark of Brother International Corporation.

Windows Vista is either a registered trademark or a trademark of Microsoft Corporation in the United States and other countries.

Microsoft, Windows, Windows Server and Internet Explorer are registered trademarks of Microsoft Corporation in the United States and/or other countries.

Apple, Macintosh, Safari and TrueType are trademarks of Apple Inc., registered in the United States and other countries.

Intel, Intel Core and Pentium are trademarks of Intel Corporation in the U.S. and other countries.

AMD is a trademark of Advanced Micro Devices, Inc.

Adobe, Flash, Illustrator, PageMaker, Photoshop, PostScript and PostScript 3 are either registered trademarks or trademarks of Adobe Systems Incorporated in the United States and/or other countries.

Epson is a registered trademark and FX-80 and FX-850 are trademarks of Seiko Epson Corporation.

IBM® is either a registered trademark or a trademark of International Business Machines Corporation in the United States and/or other countries.

Nuance, the Nuance logo, PaperPort and ScanSoft are trademarks or registered trademarks of Nuance Communications, Inc. or its affiliates in the United States and/or other countries.

All other trademarks are the property of their respective owners.

Memory board

This machine has 64 MB of standard memory and one slot for optional memory expansion. You can expand the memory up to 576 MB by installing small outline dual in-line memory modules (SO-DIMM). When you add the optional memory, it increases the performance for both copier and printer operations.

In general, the machine uses industry-standard SO-DIMMs with the following specifications:

Type: 144 pin and 64 bit output

CAS latency: 2

Clock frequency: 100 MHz or more

Capacity: 64, 128, 256 or 512 MB

Height: 31.75 mm

Dram Type: SDRAM 2 Bank

For purchasing information and part numbers visit the Buffalo Technology website:

<http://www.buffalo-technology.com/>



Note

- There may be some SO-DIMMs that will not work with the machine.
- For more information, contact your Brother dealer.

Installing extra memory

- 1 Turn off the machine's power switch.
- 2 Disconnect the interface cable from the machine, and then unplug the power cord from the electrical socket.



Note

Be sure to turn off the machine's power switch before you install or remove the SO-DIMM.

- 3 Remove the SO-DIMM cover and interface access cover.

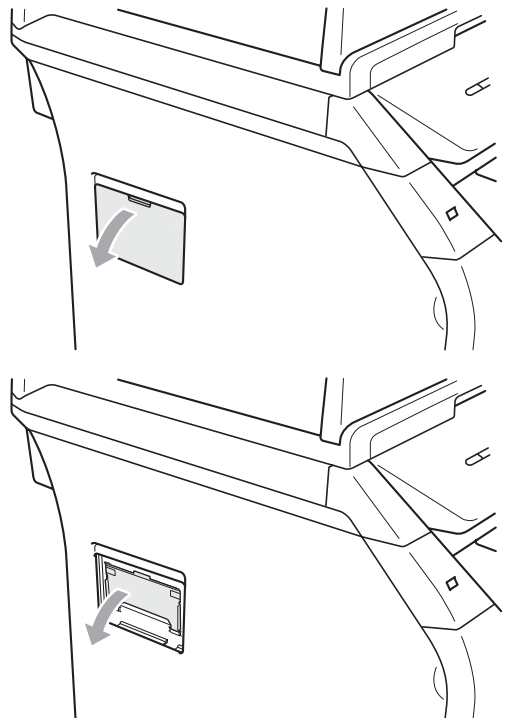

- 4 Unpack the SO-DIMM and hold it by its edges.

! IMPORTANT

To prevent damage to the machine from static electricity, DO NOT touch the memory chips or the board surface.

- 5 Hold the SO-DIMM by the edges and align the notches in the SO-DIMM with the protrusions in the slot. Insert the SO-DIMM diagonally (1), then tilt it toward the interface board until it clicks into place (2).

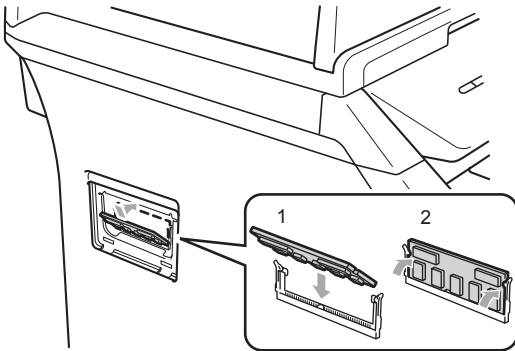

- 6 Put the interface access cover and the SO-DIMM cover back on.
- 7 Plug the machine's power cord back into the electrical socket first, and then connect the interface cable.
- 8 Turn on the machine's power switch.



Note

To make sure that you have installed the SO-DIMM properly, you can print the user settings page that shows the current memory size. (See *User Settings List* on page 23)

Troubleshooting

If you think there is a problem with your machine, check the chart below and follow the troubleshooting tips.

Most problems can be easily resolved by yourself. If you need additional help, the Brother Solutions Center offers the latest FAQs and troubleshooting tips. Visit us at <http://solutions.brother.com/>.

If you are having difficulty with your machine

Check the chart below and follow the troubleshooting tips.

Menu access difficulties

Difficulties	Suggestions
Key operations do not work.	Check the control panel is fitted correctly on the machine. Reinstall the control panel.

Copy difficulties

Difficulties	Suggestions
Vertical black line appears in copies.	Black vertical lines on copies are typically caused by dirt or correction fluid on the glass strip, or the corona wire for printing is dirty. (See <i>Cleaning the scanner</i> on page 78 and <i>Cleaning the corona wire</i> on page 81.)
The machine does not scan all the pages of your document.	Make sure that the ADF output tray does not contain more than 20 sheets.

Printing difficulties

Difficulties	Suggestions
No printout.	<ul style="list-style-type: none"> ■ Check that the machine is plugged in and the power switch is turned on. ■ Check that the toner cartridge and drum unit are installed correctly. (See <i>Replacing the drum unit</i> on page 88.) ■ Check the interface cable connection on both the machine and your computer. (See the <i>Quick Setup Guide</i>.) ■ Check that the correct printer driver has been installed and chosen. ■ Check to see if the LCD is showing an error message. (See <i>Error and maintenance messages</i> on page 66.) ■ Check the machine is online: (Windows® Vista®) Click the Start button, Control Panel, Hardware and Sound, and then Printers. Right-click Brother DCP-XXXX Printer. Make sure that Use Printer Offline is unchecked. (Windows® XP) Click the Start button and choose Printers. Right-click Brother DCP-XXXX Printer. Make sure that Use Printer Offline is unchecked. (Windows® 2000) Click the Start button and choose Settings and then Printers. Right-click Brother DCP-XXXX Printer. Make sure that Use Printer Offline is unchecked.
The machine prints unexpectedly or it prints garbage.	<ul style="list-style-type: none"> ■ Pull out the paper tray and wait until the machine stops printing. Then turn off the machine and disconnect from the power for several minutes. ■ Check the settings in your application to make sure it is set up to work with your machine.
The machine prints the first couple of pages correctly, then some pages have text missing.	<ul style="list-style-type: none"> ■ Check the settings in your application to make sure that it is set up to work with your machine. ■ Your computer is not recognising the machine's input buffer's full signal. Make sure that you connected the interface cable correctly. (See the <i>Quick Setup Guide</i>.)
The headers or footers appear when the document displays on the screen but they do not show up when it is printed.	There is an unprintable area on the top and bottom of the page. Adjust the top and bottom margins in your document to allow for this.
The machine does not print on both sides of the paper even though the printer driver setting is Duplex.	Check the paper size setting in the printer driver. You need to choose A4 size of paper. (60 to 105 g/m ²)
The machine is not printing or has stopped printing and the machine's Data LED is on.	<p>Press Job Cancel.</p> <p>As the machine cancels the Job and clears it from the memory it may produce an incomplete printout.</p>

Scanning difficulties

Difficulties	Suggestions
TWAIN errors appear while scanning.	Make sure that the Brother TWAIN driver is chosen as the primary source. In PaperPort™ 11SE, click File, Scan or Get Photo and choose the Brother TWAIN driver .
OCR does not work.	Try increasing the scanning resolution.
The machine does not scan all the pages of your document.	Make sure that the ADF output tray does not contain more than 20 sheets.

Software difficulties

Difficulties	Suggestions
Cannot install software or print.	Run the Repair MFL-Pro Suite program on the CD-ROM. This program will repair and reinstall the software.
Cannot perform '2 in 1' or '4 in 1' printing.	Check that the paper size setting in the application and in the printer driver are the same.
The machine does not print from Adobe® Illustrator®.	Try to reduce the print resolution. (See <i>Advanced tab</i> in the <i>Software User's Guide</i> on the CD-ROM.)



Paper handling difficulties

Difficulties	Suggestions
The machine does not load paper. The LCD shows No Paper or a Paper Jam message.	<ul style="list-style-type: none"> ■ If there is no paper, load a new stack of paper into the paper tray. ■ If there is paper in the paper tray, make sure it is straight. If the paper is curled, you should straighten it. Sometimes it is helpful to remove the paper, turn the stack over and put it back into the paper tray. ■ Reduce the amount of paper in the paper tray, and then try again. ■ Check that the MP tray mode is not chosen in the printer driver. ■ If the LCD shows Paper Jam message and you still have a problem, see <i>Paper jams</i> on page 71.
The machine does not feed paper from the MP tray.	<ul style="list-style-type: none"> ■ Fan the paper well and put it back in the tray firmly. ■ Make sure that MP tray mode is chosen in the printer driver.
How do I print on envelopes?	You can load envelopes from the MP tray. Your application must be set up to print the envelope size you are using. This is usually done in the Page Setup or Document Setup menu of your application. (See your application's manual for more information.)
The scanned documents jam on the ADF output tray.	<ul style="list-style-type: none"> ■ Make sure your document is not too thin or too thick and are correctly loaded in the ADF. (See <i>Loading documents</i> on page 18.) ■ Use the scanner glass to scan the document.
What paper can I use?	You can use thin paper, plain paper, thick paper, bond paper, recycled paper, envelopes, labels and transparencies that are made for laser machines. (For details, see <i>Acceptable paper and other print media</i> on page 13.)
There is a paper jam.	(See <i>Paper jams</i> on page 71.)

Print quality difficulties

Difficulties	Suggestions
Printed pages are curled.	<ul style="list-style-type: none"> ■ Low quality thin or thick paper or not printing on the recommended side of the paper could cause this problem. Try turning over the stack of paper in the paper tray. ■ Make sure that you choose the Paper Type that suits the print media type you are using. (See <i>Acceptable paper and other print media</i> on page 13.)
Printed pages are smeared.	The Paper Type setting may be incorrect for the type of print media you are using, or the print media may be too thick or have a rough surface. (See <i>Acceptable paper and other print media</i> on page 13 and <i>Basic tab</i> in the <i>Software User's Guide</i> on the CD-ROM.)
Printouts are too light.	<ul style="list-style-type: none"> ■ If this problem occurs when making copies, set Toner Save mode to Off in the machine menu settings. (See <i>Toner Save</i> on page 22.) ■ Set Toner Save mode to Off in the Advanced tab in the printer driver. (See <i>Advanced tab</i> in the <i>Software User's Guide</i> on the CD-ROM.)

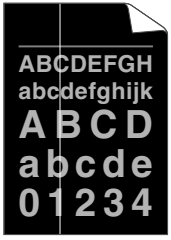
Improving the print quality

Examples of poor print quality	Recommendation
 <p>White lines across the page</p>	<ul style="list-style-type: none"> ■ Make sure that you use paper that meets our specifications. A rough surfaced paper or thick print media can cause the problem. (See <i>Acceptable paper and other print media</i> on page 13.) ■ Make sure that you choose the appropriate media type in the printer driver or in the machine's Paper Type menu setting. (See <i>Acceptable paper and other print media</i> on page 13 and <i>Basic tab</i> in the <i>Software User's Guide</i> on the CD-ROM.) ■ The problem may disappear by itself. Print multiple pages to clear this problem, especially if the machine has not been used for a long time. ■ The drum unit may be damaged. Put in a new drum unit. (See <i>Replacing the drum unit</i> on page 88.)
 <p>White lines down the page</p>	<ul style="list-style-type: none"> ■ Wipe the laser scanner windows with a dry, lint-free soft cloth. (See <i>Cleaning the laser scanner window</i> on page 79.) ■ Make sure that a torn sheet of paper is not inside the machine covering the scanner window. ■ The toner cartridge may be damaged. Put in a new toner cartridge. (See <i>Replacing a toner cartridge</i> on page 85.) ■ The drum unit may be damaged. Put in a new drum unit. (See <i>Replacing the drum unit</i> on page 88.)
 <p>Hollow print</p>	<ul style="list-style-type: none"> ■ Make sure that you use paper that meets our specifications. (See <i>Acceptable paper and other print media</i> on page 13.) ■ Choose Thick paper mode in the printer driver, choose <i>Thick</i> in the machine's Paper Type menu setting or use thinner paper than you are currently using. (See <i>Paper Type</i> on page 20 and <i>Basic tab</i> in the <i>Software User's Guide</i> on the CD-ROM.) ■ Check the machine's environment. Conditions such as high humidity can cause hollow print. (See <i>Choosing a location</i> on page 44.) ■ The drum unit may be damaged. Put in a new drum unit. (See <i>Replacing the drum unit</i> on page 88.)
 <p>Grey background</p>	<ul style="list-style-type: none"> ■ Make sure that you use paper that meets our specifications. (See <i>Acceptable paper and other print media</i> on page 13.) ■ Check the machine's environment. Conditions such as high temperatures and high humidity can increase the amount of background shading. (See <i>Choosing a location</i> on page 44.) ■ The toner cartridge may be damaged. Put in a new toner cartridge. (See <i>Replacing a toner cartridge</i> on page 85.) ■ The drum unit may be damaged. Put in a new drum unit. (See <i>Replacing the drum unit</i> on page 88.)

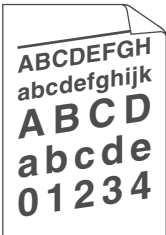
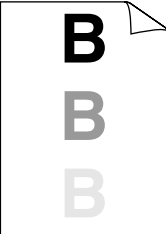
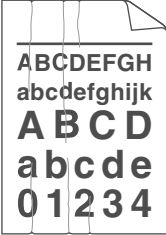
Examples of poor print quality	Recommendation
 <p data-bbox="203 552 356 581">Page skewed</p>	<ul style="list-style-type: none"> <li data-bbox="477 295 1212 378">■ Make sure that the paper or other print media is loaded correctly in the paper tray and that the guides are not too tight or too loose against the paper stack. <li data-bbox="477 394 1212 450">■ Set the paper guides correctly. (See <i>Loading paper in the standard paper tray</i> on page 9.) <li data-bbox="477 465 1212 521">■ If you are using the MP tray, see <i>Loading paper in the multi-purpose tray (MP tray)</i> on page 10. <li data-bbox="477 537 828 566">■ The paper tray may be too full. <li data-bbox="477 581 1212 637">■ Check the paper type and quality. (See <i>Acceptable paper and other print media</i> on page 13.)
 <p data-bbox="244 909 315 938">Ghost</p>	<ul style="list-style-type: none"> <li data-bbox="477 649 1212 734">■ Make sure that you use paper that meets our specifications. Rough-surfaced paper or thick paper may cause the problem. (See <i>Acceptable paper and other print media</i> on page 13.) <li data-bbox="477 749 1212 863">■ Make sure that you choose the correct media type in the printer driver or in the machine's Paper Type menu setting. (See <i>Acceptable paper and other print media</i> on page 13 and <i>Basic tab</i> in the <i>Software User's Guide</i> on the CD-ROM.) <li data-bbox="477 879 1157 935">■ The drum unit may be damaged. Put in a new drum unit. (See <i>Replacing the drum unit</i> on page 88.) <li data-bbox="477 950 1185 1006">■ The fuser unit may be contaminated. Call your Brother dealer for service.
 <p data-bbox="166 1282 393 1311">Wrinkles or creases</p>	<ul style="list-style-type: none"> <li data-bbox="477 1022 1212 1078">■ Check the paper type and quality. (See <i>Acceptable paper and other print media</i> on page 13.) <li data-bbox="477 1093 1212 1149">■ Make sure that paper is loaded correctly. (See <i>Loading paper in the standard paper tray</i> on page 9.) <li data-bbox="477 1164 1212 1221">■ Turn over the stack of paper in the paper tray or rotate the paper 180° in the paper tray.

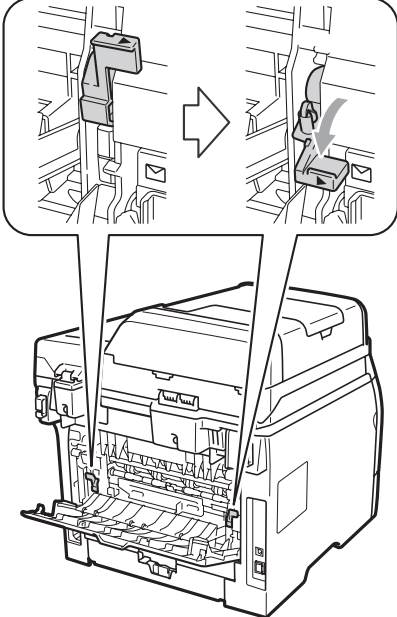
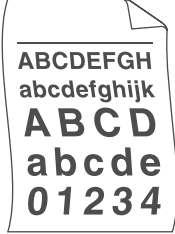
Examples of poor print quality	Recommendation
 <p data-bbox="207 521 412 548">Envelope creases</p>	<ul style="list-style-type: none"> <li data-bbox="504 295 1249 353">■ Make sure that the envelope levers inside the back cover are pulled down when you print envelopes. 
 <p data-bbox="222 1265 395 1292">Curled or wavy</p>	<ul style="list-style-type: none"> <li data-bbox="504 1010 1190 1068">■ Check the paper type and quality. High temperatures and high humidity will cause paper to curl. <li data-bbox="504 1078 1249 1193">■ If you do not use the machine often, the paper may have been in the paper tray too long. Turn over the stack of paper in the paper tray. Also, fan the paper stack and then rotate the paper 180° in the paper tray.

Examples of poor print quality



Curled

Recommendation

■ Turn the paper over in the paper tray, and print again (excluding Letterhead paper). If the problem remains, slide the Anti-Curl Switch as follows:

1 Open the back cover.

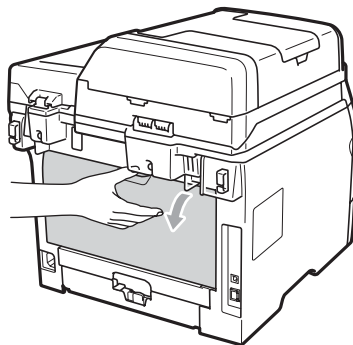

2 With one hand, use the tab (1) to lift the roller assembly, then use your other hand to slide the Anti-Curl Switch (2) in the direction of the arrow.

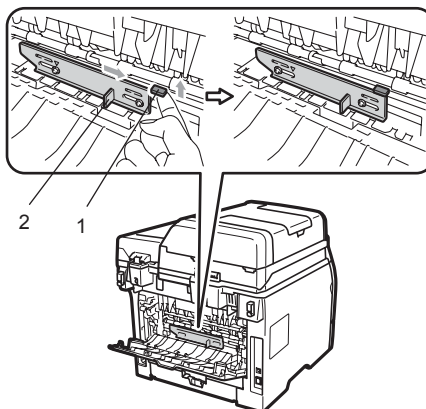



3 Close the back cover.

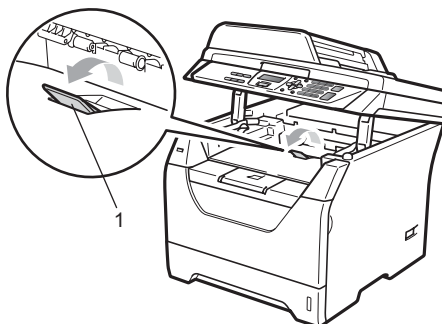

■ Lift up the Output Tray Support Flap (1).

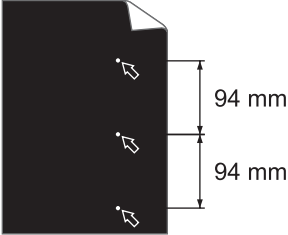
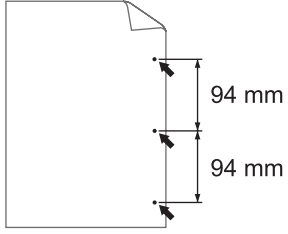

■ Choose **Reduce Paper Curl** mode in the printer driver. (See *Other Print Options (For Windows®)* or *Print Settings (For Macintosh)* in the *Software User's Guide* on the CD-ROM.)

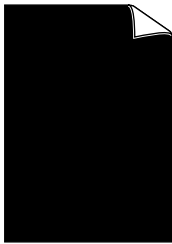
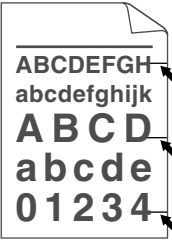
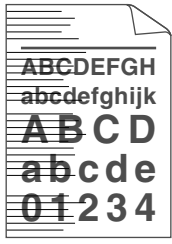
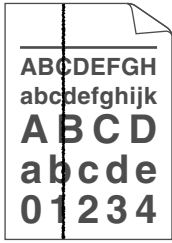
Examples of poor print quality	Recommendation
 <p>White Spots on black text and graphics at 94 mm intervals</p>  <p>Black Spots at 94 mm intervals</p>	<ul style="list-style-type: none"> ■ Make ten copies of a blank, white sheet of paper. (See <i>Making multiple copies</i> on page 26.) If the problem is not solved, the drum unit may have glue from a label stuck on the OPC drum surface. Clean the drum unit. (See <i>Cleaning the drum unit</i> on page 82.) ■ The drum unit may be damaged. Put in a new drum. (See <i>Replacing the drum unit</i> on page 88.)
 <p>Faint</p>	<ul style="list-style-type: none"> ■ Check the machine's environment. Conditions such as humidity, high temperatures, and so on, may cause this print fault. (See <i>Choosing a location</i> on page 44.) ■ If the whole page is too light, Toner Save mode may be on. Turn off Toner Save mode in the machine menu settings or Toner Save mode in the printer Properties of the driver. (See <i>Toner Save</i> on page 22 or <i>Advanced tab</i> in the <i>Software User's Guide</i> on the CD-ROM.) ■ Clean the scanner window and the corona wire of the drum unit. (See <i>Cleaning the laser scanner window</i> on page 79 and <i>Cleaning the corona wire</i> on page 81.) ■ The toner cartridge may be damaged. Put in a new toner cartridge. (See <i>Replacing a toner cartridge</i> on page 85.) ■ The drum unit may be damaged. Put in a new drum unit. (See <i>Replacing the drum unit</i> on page 88.)
 <p>Toner specks</p>	<ul style="list-style-type: none"> ■ Make sure that you use paper that meets our specifications. Rough-surfaced paper may cause the problem. (See <i>Acceptable paper and other print media</i> on page 13.) ■ Clean the corona wire and the drum unit. (See <i>Cleaning the corona wire</i> on page 81 and <i>Cleaning the drum unit</i> on page 82.) ■ The drum unit may be damaged. Put in a new drum unit. (See <i>Replacing the drum unit</i> on page 88.) ■ The fuser unit may be contaminated. Call your Brother dealer for service.

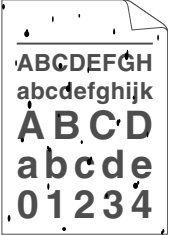
Examples of poor print quality	Recommendation
 <p data-bbox="227 556 330 581">All black</p>	<ul style="list-style-type: none"> <li data-bbox="477 295 1218 378">■ Clean the corona wire inside the drum unit by sliding the blue tab. Be sure to return the blue tab to the home position (▲). (See <i>Cleaning the corona wire</i> on page 81.) <li data-bbox="477 394 1157 450">■ The drum unit may be damaged. Put in a new drum unit. (See <i>Replacing the drum unit</i> on page 88.) <li data-bbox="477 465 1185 521">■ The fuser unit may be contaminated. Call your Brother dealer for service.
 <p data-bbox="113 857 440 913">Black toner marks across the page</p>	<ul style="list-style-type: none"> <li data-bbox="477 600 1195 656">■ Make sure that you use paper that meets our specifications. (See <i>Acceptable paper and other print media</i> on page 13.) <li data-bbox="477 672 1218 755">■ If you use label sheets for laser machines, the glue from the sheets may sometimes stick to the OPC drum surface. Clean the drum unit. (See <i>Cleaning the drum unit</i> on page 82.) <li data-bbox="477 770 1218 826">■ Do not use paper that has clips or staples because they will scratch the surface of the drum. <li data-bbox="477 842 1208 898">■ If the unpacked drum unit is in direct sunlight or room light, the unit may be damaged. <li data-bbox="477 913 1208 969">■ The toner cartridge may be damaged. Put in a new toner cartridge. (See <i>Replacing a toner cartridge</i> on page 85.) <li data-bbox="477 985 1157 1041">■ The drum unit may be damaged. Put in a new drum unit. (See <i>Replacing the drum unit</i> on page 88.)
 <p data-bbox="159 1311 399 1336">Line across the page</p>	<ul style="list-style-type: none"> <li data-bbox="477 1054 1218 1137">■ Clean the laser scanner window and the corona wire inside the drum unit. (See <i>Cleaning the laser scanner window</i> on page 79 and <i>Cleaning the corona wire</i> on page 81.) <li data-bbox="477 1153 1157 1209">■ The drum unit may be damaged. Put in a new drum unit. (See <i>Replacing the drum unit</i> on page 88.)
 <p data-bbox="131 1611 426 1707">Black lines down the page Printed pages have toner stains down the page</p>	<ul style="list-style-type: none"> <li data-bbox="477 1354 1218 1437">■ Clean the corona wire inside the drum unit by sliding the blue tab. Be sure to return the blue tab to the home position (▲). (See <i>Cleaning the corona wire</i> on page 81.) <li data-bbox="477 1452 1208 1508">■ The toner cartridge may be damaged. Put in a new toner cartridge. (See <i>Replacing a toner cartridge</i> on page 85.) <li data-bbox="477 1524 1157 1580">■ The drum unit may be damaged. Put in a new drum unit. (See <i>Replacing the drum unit</i> on page 88.) <li data-bbox="477 1595 1222 1620">■ The fuser unit may be smudged. Call your Brother dealer for service.

Examples of poor print quality	Recommendation
 <p data-bbox="244 552 375 581">Poor fixing</p>	<ul style="list-style-type: none"> <li data-bbox="504 295 1248 353">■ Open the back cover and make sure that the two blue levers on the left and right hand sides are in the up position.  <ul style="list-style-type: none"> <li data-bbox="504 933 1248 1020">■ Choose Improve Toner Fixing mode in the printer driver. (See <i>Other Print Options</i> (For Windows®) or <i>Print Settings</i> (For Macintosh) in the <i>Software User's Guide</i> on the CD-ROM.) <p data-bbox="532 1039 1199 1087">If this selection does not provide enough improvement, choose Thicker Paper in Media Type settings.</p>

Error and maintenance messages

As with any sophisticated office product, errors may occur and consumable items may need to be replaced. If this happens, your machine identifies the error or required routine maintenance and shows the appropriate message. The most common error and maintenance messages are shown below.

You can clear most errors and perform routine maintenance messages by yourself. If you need more help, the Brother Solutions Center offers the latest FAQs and troubleshooting tips.

Visit us at <http://solutions.brother.com/>.

Error Message	Cause	Action
20 Sheet Limit	The ADF output tray has reached its maximum capacity.	Do one of the following: <ul style="list-style-type: none"> ■ To send the pages scanned so far to a server, press 1. Send. ■ To delete the scanned pages, press 2. Delete. If you send the pages already scanned and want to send the remaining pages to a server, remove the scanned sheets from the ADF output tray and press Start .
Access Error	The device is removed from the USB direct interface while the data is processing.	Press Stop/Exit . Reinsert the device and try to print with Direct Print.
Cartridge Error	The toner cartridge is not installed correctly.	Pull out the drum unit, take out the toner cartridge and put it back into the drum unit again.
Cooling Down Wait for a while	The temperature of the drum unit or toner cartridge is too hot. The machine will pause its current print job and go into cooling down mode. During the cooling down mode, you will hear the cooling fan running while the LCD shows Cooling Down, and Wait for a while.	Make sure that you can hear the fan in the machine spinning and that the exhaust outlet is not blocked by something. If the fan is spinning, remove any obstacles that surround the exhaust outlet, and then leave the machine turned on but do not use it for several minutes. If the fan is not spinning disconnect the machine from the power for several minutes, then reconnect it.
Cover is Open	The front cover is not closed completely.	Close the front cover of the machine.
Cover is Open	The fuser cover is not closed completely or paper was jammed in the back of the machine when you turned on the power.	<ul style="list-style-type: none"> ■ Close the fuser cover of the machine. ■ Make sure paper is not jammed inside the back of the machine, and then close the fuser cover and press Start.
	The ADF is open while loading a document.	Close the ADF cover of the machine and press Stop/Exit .
Cover is Open	The ADF cover is not closed completely.	Close the ADF cover of the machine and press Stop/Exit .

Error Message	Cause	Action
Document Jam	The document was not inserted or fed correctly, or the document scanned from the ADF was too long.	See <i>Document jams</i> on page 70 or <i>Using the automatic document feeder (ADF)</i> on page 18.
Drum Error	The corona wire on the drum unit needs to be cleaned.	Clean the corona wire on the drum unit. (See <i>Cleaning the corona wire</i> on page 81.)
	The drum unit has reached the end of its life.	Replace the drum unit. (See <i>Replacing the drum unit</i> on page 88.)
Duplex Disabled	The duplex tray is not installed properly.	Remove the duplex tray and install it again.
Fuser Error	The temperature of fuser unit does not rise at a specified temperature within specified time.	Turn the power switch off, wait a few seconds, and then turn it on again. Leave the machine for 15 minutes with the power on.
	The fuser unit is too hot.	
Jam Duplex	The paper is jammed in the duplex tray.	(See <i>Paper jams</i> on page 71.)
Jam Inside	The paper is jammed inside the machine.	(See <i>Paper jams</i> on page 71.)
Jam MP Tray	The paper is jammed in the MP tray of the machine.	(See <i>Paper jams</i> on page 71.)
Jam Rear	The paper is jammed in the back of the machine.	(See <i>Paper jams</i> on page 71.)
Jam Tray 1	The paper is jammed in the paper tray of the machine.	(See <i>Paper jams</i> on page 71.)
No Paper	The machine is out of paper or paper is not correctly loaded in the paper tray.	Do one of the following: <ul style="list-style-type: none"> ■ Refill the paper in the paper tray or MP tray. ■ Remove the paper and load it again.
No Toner	The toner cartridge or the drum unit and toner cartridge assembly is not installed properly.	Re-install the toner cartridge or the drum unit and toner cartridge assembly.
No Tray	The paper tray is not completely closed.	Close the paper tray properly.

Error Message	Cause	Action
Out of Memory	The machine's memory is full.	<p>Copy operation in progress</p> <p>Do one of the following:</p> <ul style="list-style-type: none"> ■ Press Start to copy the scanned pages. ■ Press Stop/Exit and wait until the other operations in progress finish, and then try again. ■ Clear the data from the memory. (See <i>Out of memory message</i> on page 33.) <p>Print operation in process</p> <p>Reduce print resolution. (See <i>Advanced tab</i> in the <i>Software User's Guide</i> on the CD-ROM.)</p>
Output Tray Full	The ADF output tray has reached its maximum capacity	Remove the scanned pages from the ADF output tray. If you want to scan the remaining pages of your documents press Start .
Print Unable XX	The machine has a mechanical problem.	Disconnect the machine from the power for several minutes, then reconnect it.
Protected Device	The protect switch of the USB Flash memory drive is on.	Turn off the protect switch of the USB Flash memory drive.
Rename the File	There is already a file on the USB Flash memory drive with the same name as the file you are trying to save.	Change the file name of the file on the USB Flash memory drive or the file you are trying to save.
Replace Drum	The drum unit is the end of its life.	Replace the drum unit with a new one. (See <i>Replacing the drum unit</i> on page 88.)
	The drum unit counter was not reset when a new drum was installed.	<ol style="list-style-type: none"> 1 Open the front cover, and then press Clear/Back. 2 Press 1 to reset.
Replace Fuser	It is time to replace the fuser unit.	Call your Brother dealer to replace the fuser unit.
Replace Laser	It is time to replace the laser unit.	Call your Brother dealer to replace the laser unit.
Replace PF Kit1	It is time to replace the paper feeding kit for Tray 1.	Call your Brother dealer to replace the PF Kit 1.
Replace PF KitMP	It is time to replace the paper feeding kit for the MP tray.	Call your Brother dealer to replace the PF Kit MP.
Replace Toner	The toner cartridge is at the end of its life and printing is not possible.	Replace the toner cartridge with a new one. (See <i>Replacing a toner cartridge</i> on page 85.)
Scan Unable XX	The machine has a mechanical problem.	Disconnect the machine from the power for several minutes, then reconnect it.

Error Message	Cause	Action
Toner Low	If the LCD shows Toner Low, you can still print; however, the machine is telling you that the toner cartridge is near the end of its life and the toner will soon need replacing.	Order a new toner cartridge now.
Too Many Files	There are too many files stored on the USB Flash memory drive.	Reduce the number of files stored on the USB Flash memory drive.
Unable to Scan.	There is a document in the ADF input and output tray.	Remove the document from the ADF output tray.
Unusable Device	An incompatible or broken device has been connected to the USB direct interface.	Remove the USB Flash memory drive from the USB direct interface.

Document jams

If the document is jammed, follow the steps below.

! IMPORTANT

After removing a jammed document, check that no paper scraps are left in the machine that could cause another jam.

Document is jammed in the top of the ADF unit

- 1 Take out any paper from the ADF that is not jammed.
- 2 Open the ADF cover.
- 3 Pull the jammed document out to the right.

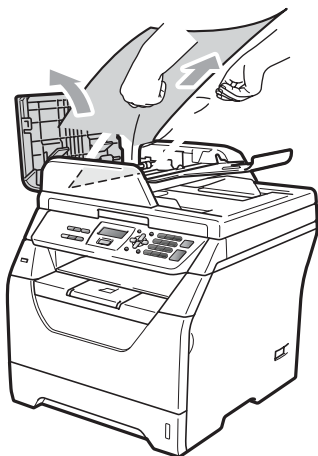

- 4 Close the ADF cover.
- 5 Press **Stop/Exit**.

Document is jammed under the document cover

- 1 Take out any paper from the ADF that is not jammed.
- 2 Lift the document cover.
- 3 Pull the jammed document out to the left.

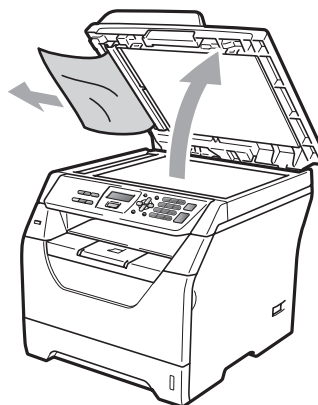

- 4 Close the document cover.
- 5 Press **Stop/Exit**.

Document is jammed at the ADF output tray

- 1 Take out any paper from the ADF that is not jammed.
- 2 Pull the jammed document out to the right.



- 3 Press **Stop/Exit**.

Paper jams

To clear paper jams, please follow the steps in this section.

! IMPORTANT

- Please confirm that you have installed both a toner cartridge and a drum unit in the machine. If you have not installed a drum unit or have installed the drum unit incorrectly, then this may cause a paper jam in your Brother machine.
- To prevent damage to the machine caused by static electricity, **DO NOT** touch the electrodes shown in the illustration.

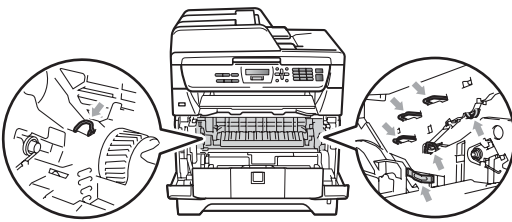

Note

- If the error message remains, open and close the front cover and fuser cover firmly to reset the machine.
- The LCD names for the paper trays are as follows:
 - Standard paper tray: Tray 1
 - Multi-purpose tray: MP Tray

Paper is jammed in the MP tray

If the LCD shows Jam MP Tray, follow these steps:

- 1 Remove the paper from the MP tray.
- 2 Remove any jammed paper from in and around the MP tray.

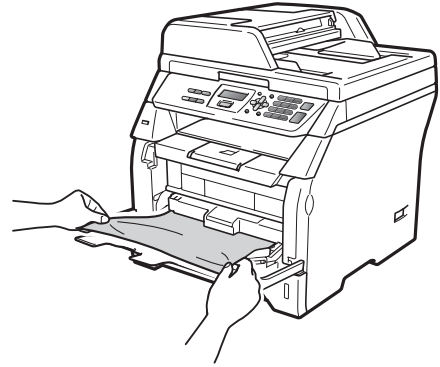

- 3 Press **Start**.
- 4 Fan the paper stack, and then put it back in the MP tray.

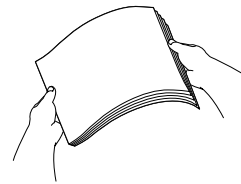

- 5 When loading paper in the MP tray, make sure that the paper stays under the maximum paper height guides on both sides of the tray.

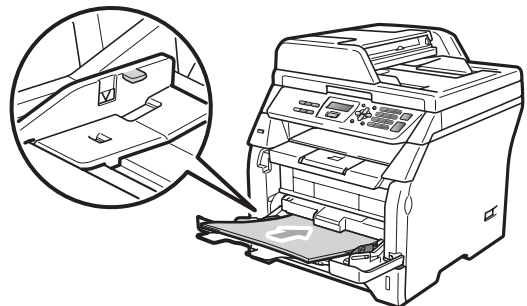

Paper is jammed in Paper Tray 1

If the LCD shows Jam Tray 1, follow these steps:

- 1 Pull the paper tray completely out of the machine.

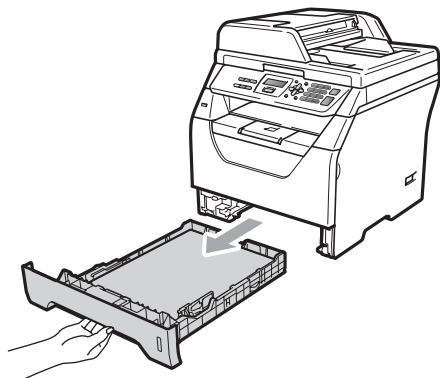

- 2 Use both hands to slowly pull out the jammed paper.

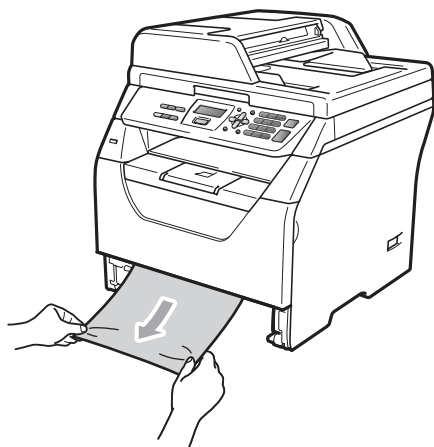

- 3 Make sure the paper is below the maximum paper mark (▼) of the paper tray. While pressing the blue paper-guide release lever, slide the paper guides to fit the paper size. Make sure that the guides are firmly in the slots.

- 4 Put the paper tray firmly back in the machine.

Paper is jammed inside the machine

- 1 Turn off the machine's power switch. Disconnect all cables and then unplug the power cord from the electrical socket.
- 2 Pull the paper tray completely out of the machine.
- 3 Use both hands to slowly pull out the jammed paper.

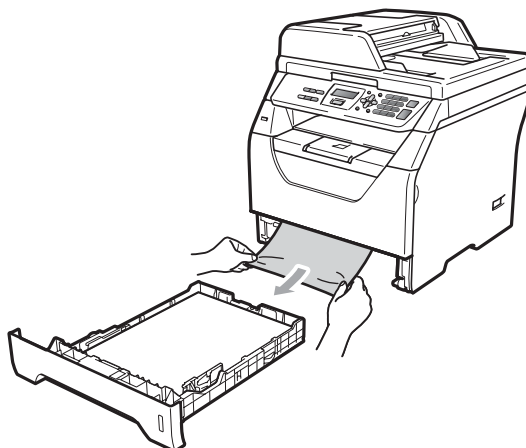

- 4 Press the front cover release button and open the front cover.

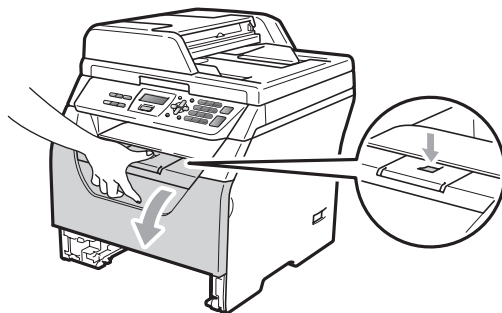

⚠ CAUTION

🔥 HOT SURFACE

After you have just used the machine, some internal parts of the machine will be extremely hot. Wait at least 10 minutes for the machine to cool down before attempting to clear the paper jam.

- 5 Slowly take out the drum unit and toner cartridge assembly. The jammed paper may be pulled out with the drum unit and toner cartridge assembly, or this may release the paper so you can pull it out of the paper tray opening.

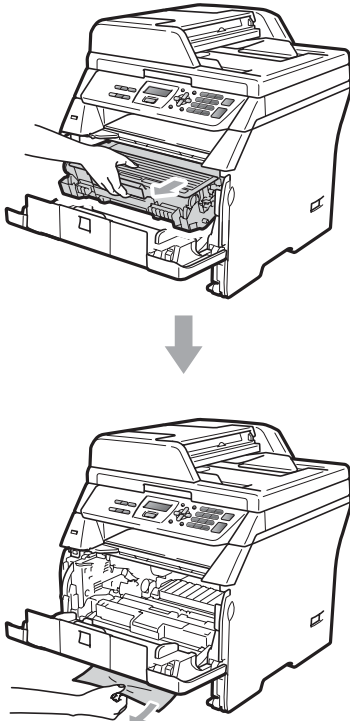

! IMPORTANT

We recommend that you place the drum unit and toner cartridge assembly on a clean, flat surface with a sheet of disposable paper or cloth underneath it in case you accidentally spill or scatter toner.

To prevent damage to the machine from static electricity, DO NOT touch the electrodes shown in the illustration.

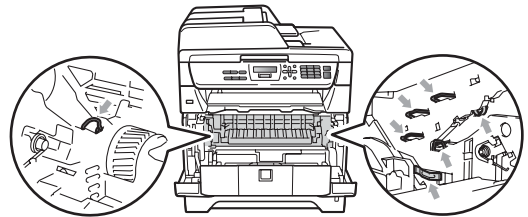

- 6 Put the drum unit and toner cartridge assembly back in the machine.

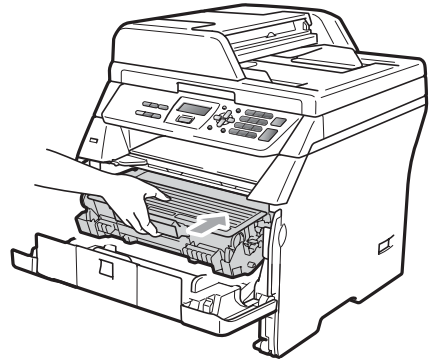

- 7 Close the front cover.
- 8 Put the paper tray firmly back in the machine.
- 9 Plug the machine's power cord back into the electrical socket first, and reconnect all cables. Turn on the machine's power switch.

Paper is jammed inside the drum unit and toner cartridge assembly

- 1 Turn off the machine's power switch. Disconnect all cables and then unplug the power cord from the electrical socket.
- 2 Press the front cover release button and open the front cover.

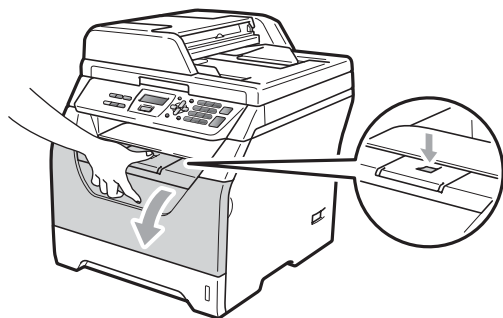

⚠ CAUTION

🔥 HOT SURFACE

After you have just used the machine, some internal parts of the machine will be extremely hot. Wait at least 10 minutes for the machine to cool down before attempting to clear the paper jam.

- 3 Slowly take out the drum unit and toner cartridge assembly.

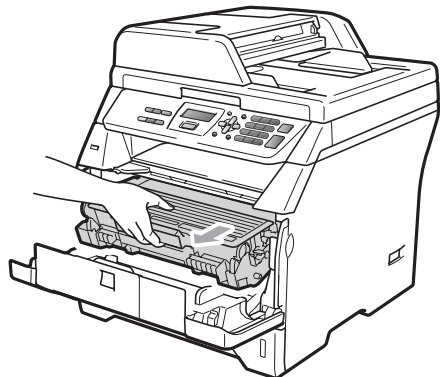

! IMPORTANT

We recommend that you place the drum unit and toner cartridge assembly on a clean, flat surface with a sheet of disposable paper or cloth underneath it in case you accidentally spill or scatter toner.

- 4 Push down the blue lock lever and take the toner cartridge out of the drum unit. Take out the jammed paper if there is any inside the drum unit.

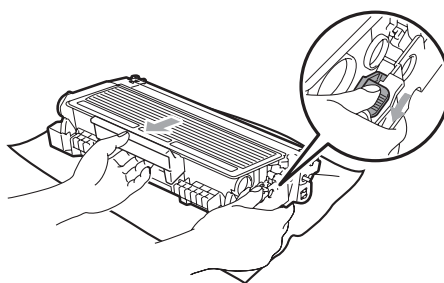

! IMPORTANT

- Handle the toner cartridge carefully. If toner scatters on your hands or clothes, wipe or wash it off with cold water at once.
- To avoid print quality problems, DO NOT touch the shaded parts shown in the illustrations below.

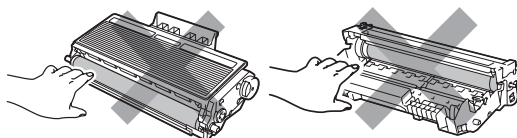

- 5 Clear the jammed paper if there is any inside the drum unit.

- 6 Put the toner cartridge back into the drum unit until you hear it lock into place. If you put it in correctly, the blue lock lever will lift automatically.

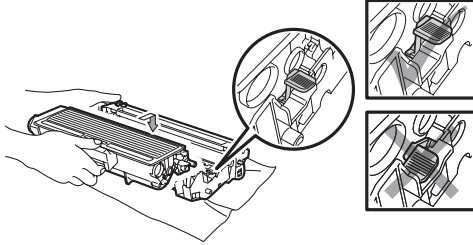

- 7 Put the drum unit and toner cartridge assembly back in the machine.

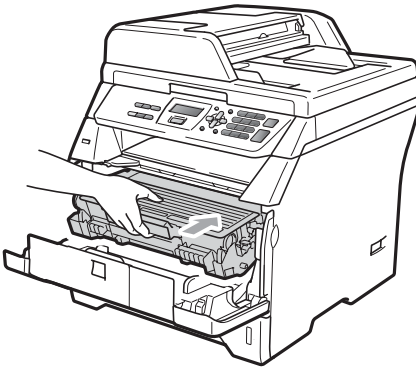

- 8 Close the front cover.
- 9 Plug the machine's power cord back into the electrical socket first, and reconnect all cables. Turn on the machine's power switch.

Paper is jammed at the back of the machine

- 1 Turn off the machine's power switch. Disconnect all cables and then unplug the power cord from the electrical socket.
- 2 Press the front cover release button and open the front cover.

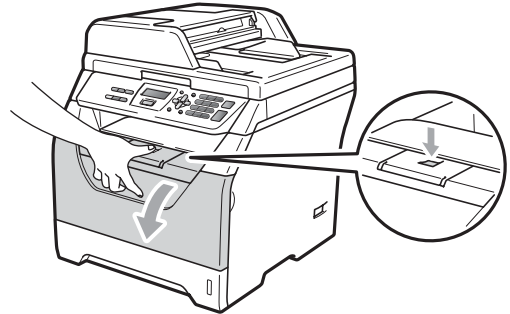

⚠ CAUTION

🔥 HOT SURFACE

After you have just used the machine, some internal parts of the machine will be extremely hot. Wait at least 10 minutes for the machine to cool down before attempting to clear the paper jam.

- 3 Slowly take out the drum unit and toner cartridge assembly.

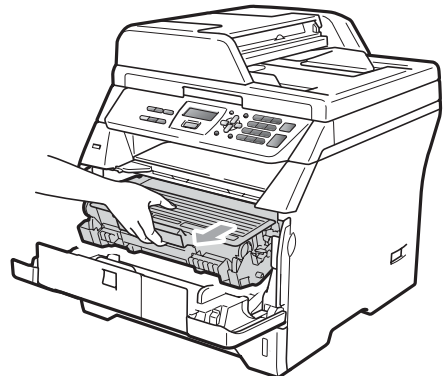

! IMPORTANT

We recommend that you place the drum unit and toner cartridge assembly on a clean, flat surface with a sheet of disposable paper or cloth underneath it in case you accidentally spill or scatter toner.

- 4 Open the back cover (back output tray).

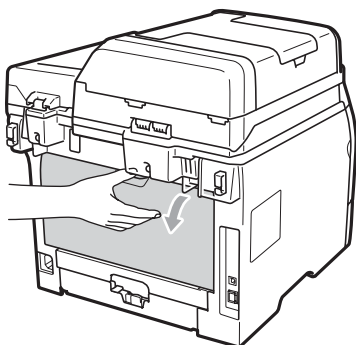

- 5 Pull the tabs at the left and right hand sides toward you to open the fuser cover (1).

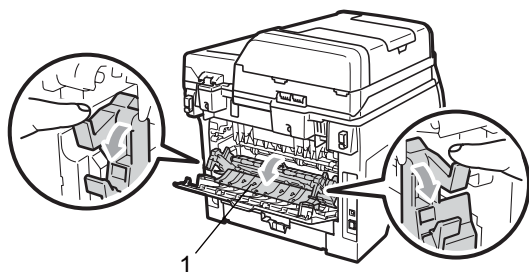

- 6 Pull the jammed paper out of the fuser unit.

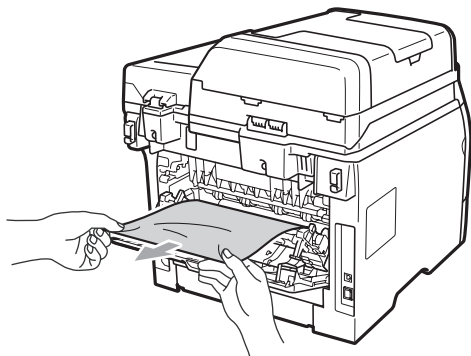

- 7 Close the fuser cover and back cover (back output tray).
- 8 Put the drum unit and toner cartridge assembly back in the machine.

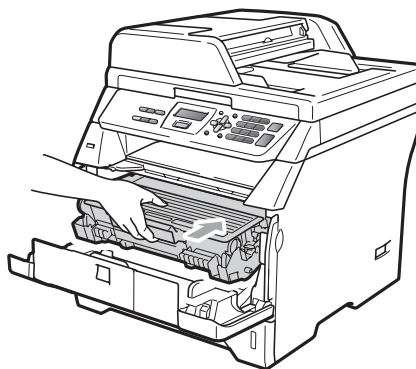

- 9 Close the front cover.
- 10 Plug the machine's power cord back into the electrical socket first, and reconnect all cables. Turn on the machine's power switch.

Paper is jammed in the duplex tray

- 1 Pull the duplex tray completely out of the machine.

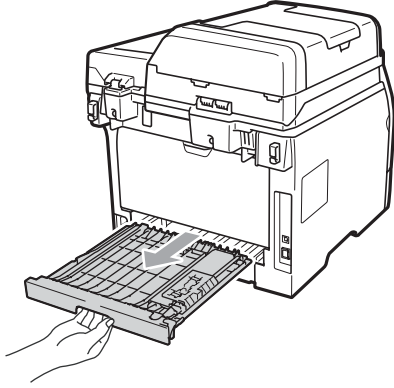

- 2 Pull the jammed paper out of the machine or the duplex tray.

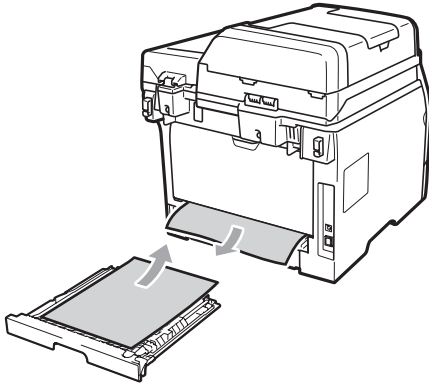

- 3 Put the duplex tray back in the machine.

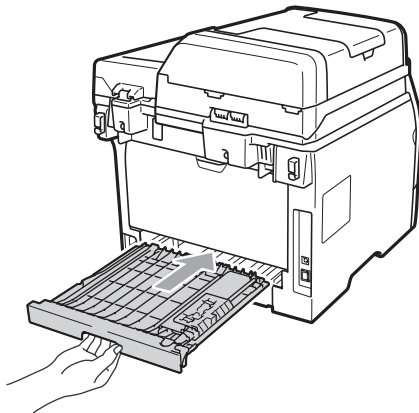

Routine maintenance

! WARNING

Use neutral detergents.

DO NOT use any flammable substances, spray or organic solvent/liquids containing alcohol/ammonia to clean the inside or outside of the machine. Doing this may cause a fire or electrical shock. (For more information see *Important safety instructions* on page 49.)

! IMPORTANT

The drum unit contains toner, so handle it carefully. If toner scatters on your hands or clothes, wipe or wash it off with cold water at once.

Cleaning the outside of the machine

- 1 Turn off the machine. Disconnect all cables and then unplug the power cord from the electrical socket.
- 2 Pull the paper tray completely out of the machine.

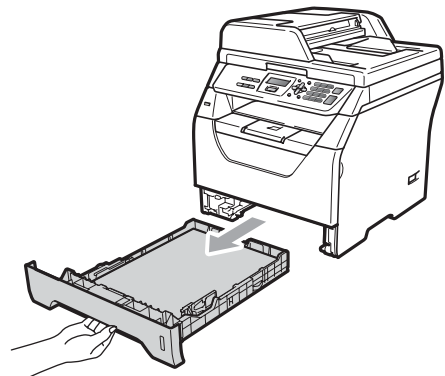

- Wipe the outside of the machine with a dry, lint-free soft cloth to remove dust.



- Remove any paper that is in the paper tray.

- Wipe the inside and the outside of the paper tray with a dry, lint-free soft cloth to remove dust.

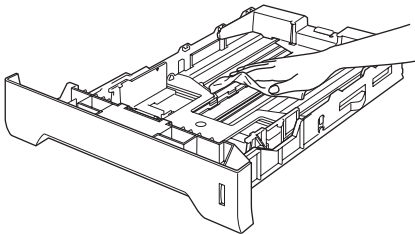

- Re-load the paper and put the paper tray firmly back in the machine.

- Plug the machine's power cord back into the electrical socket first and reconnect all cables. Turn on the machine.

Cleaning the scanner

- Turn off the machine. Disconnect all cables and then unplug the power cord from the electrical socket.
- Lift the document cover (1). Clean the white plastic surface (2) and scanner glass (3) underneath it with a soft lint-free cloth moistened with water.

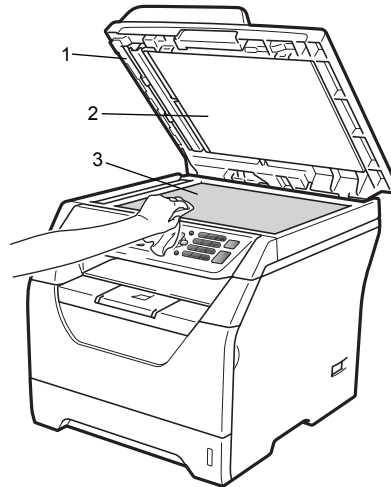

- In the ADF unit, clean the white bar (1) and the scanner glass strip (2) underneath it with a soft lint-free cloth moistened with water.

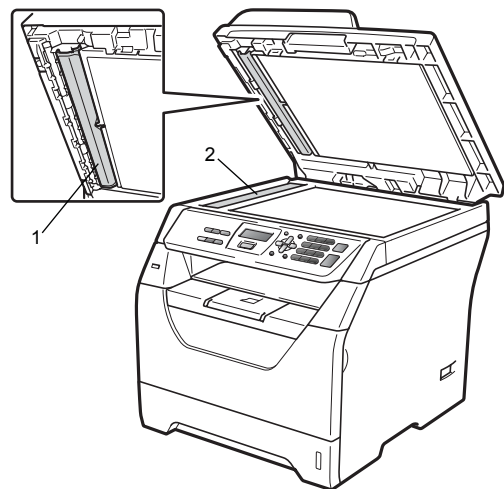

- 4 Plug the machine's power cord back into the electrical socket first and reconnect all cables. Turn on the machine.

 **Note**

In addition to cleaning the scanner glass and glass strip with a soft lint-free cloth moistened with water, run your finger tip over the glass to see if you can feel anything on it. If you feel dirt or debris, clean the glass again concentrating on that area. You may need to repeat the cleaning process three or four times. To test, make a copy after each cleaning.

Cleaning the laser scanner window

WARNING

Use neutral detergents.

DO NOT use any flammable substances, spray or organic solvent/liquids containing alcohol/ammonia to clean the inside or outside of the machine. Doing this may cause a fire or electrical shock. For more information see *Important safety instructions* on page 49.

IMPORTANT

DO NOT touch the laser scanner window with your fingers.

- 1 Before you clean the inside of the machine, turn off the machine. Disconnect all cables and then unplug the power cord from the electrical socket.
- 2 Open the front cover and slowly take out the drum unit and toner cartridge assembly.

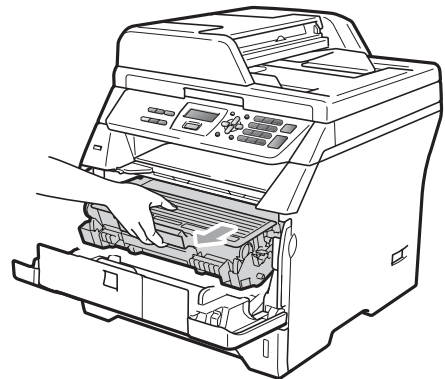

⚠ CAUTION

🔥 HOT SURFACE

After you have just used the machine, some internal parts of the machine will be extremely hot. Wait at least 10 minutes for the machine to cool down before attempting to clear the paper jam.

❗ IMPORTANT

- To prevent damage to the machine caused by static electricity, **DO NOT** touch the electrodes shown in the illustration.

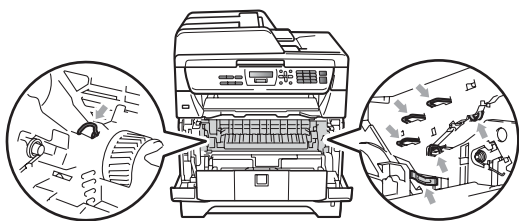

- We recommend that you place the drum unit on a clean, flat surface with a sheet of disposable paper or cloth underneath it in case you accidentally spill or scatter toner.

- 3 Wipe the laser scanner window (1) by wiping it with a dry, lint-free soft cloth.

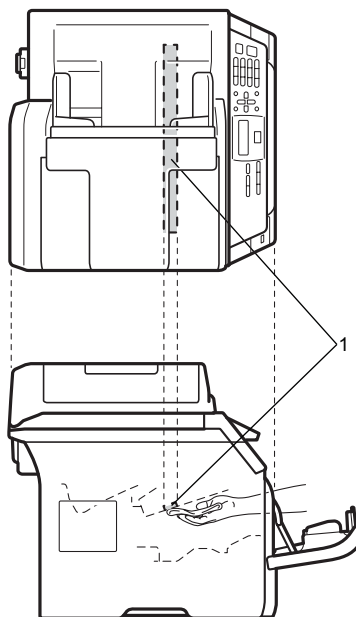

- 4 Put the drum unit and toner cartridge assembly back in the machine.

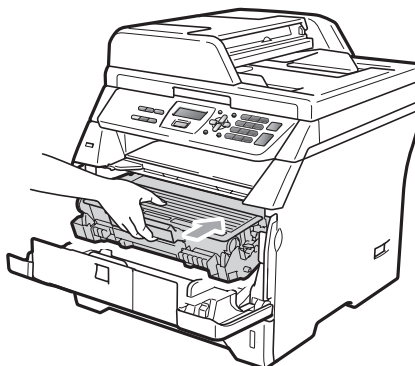

- 5 Close the front cover.
- 6 Plug the machine's power cord back into the electrical socket first, and reconnect all cables. Turn on the machine.

Cleaning the corona wire

If you have print quality problems, clean the corona wire as follows:

- 1 Turn off the machine. Disconnect all cables and then unplug the power cord from the electrical socket.
- 2 Open the front cover and slowly take out the drum unit and toner cartridge assembly.

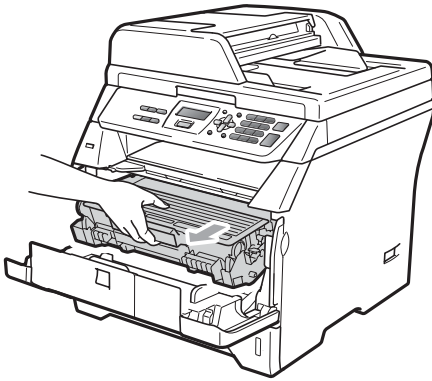

! IMPORTANT

- We recommend that you place the drum unit and toner cartridge assembly on a clean, flat surface with a sheet of disposable paper or cloth underneath it in case you accidentally spill or scatter toner.
- Handle the toner cartridge carefully. If toner scatters on your hands or clothes, wipe or wash it off with cold water at once.
- To prevent damage to the machine caused by static electricity, DO NOT touch the electrodes shown in the illustration.

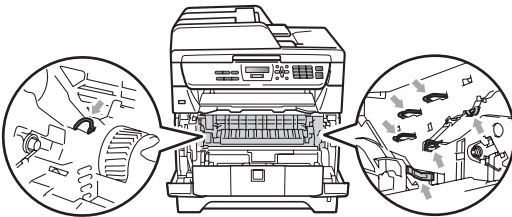

- 3 Clean the corona wire inside the drum unit by gently sliding the blue tab from right to left and left to right several times.

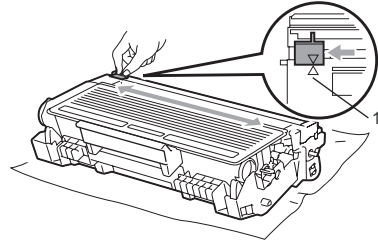

Note

Be sure to return the blue tab to the home position (▲) (1). If you do not, printed pages may have a vertical stripe.

- 4 Put the drum unit and toner cartridge assembly back in the machine.

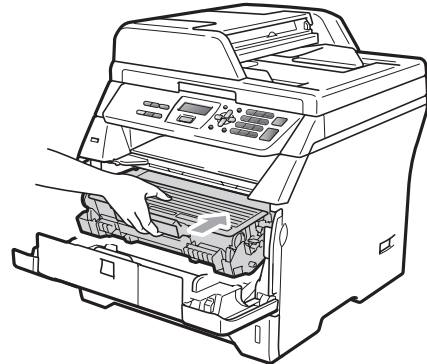

- 5 Close the front cover.

- 6 Plug the machine's power cord back into the electrical socket first and then reconnect all cables. Turn on the machine.

! IMPORTANT

To avoid print quality problems, DO NOT touch the shaded parts shown in the illustrations below.

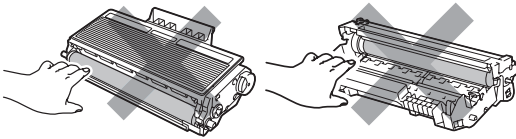

Cleaning the drum unit

If you have print quality problems, clean the drum unit as follows.

- 1 Turn off the machine. And then unplug the power cord from the electrical socket.
- 2 Open the front cover and slowly take out the drum unit and toner cartridge assembly.

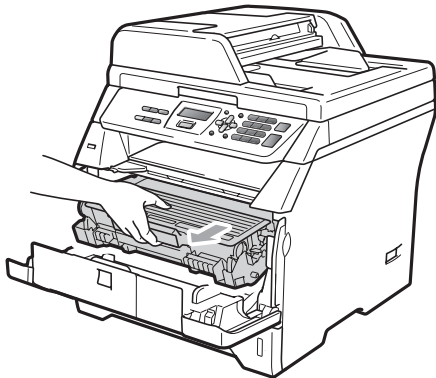

! IMPORTANT

- We recommend that you put the drum unit and toner cartridge assembly on a clean, flat surface with a sheet of disposable paper or cloth underneath it in case you accidentally spill or scatter toner.
- To prevent damage to the machine caused by static electricity, DO NOT touch the electrodes shown in the illustration.

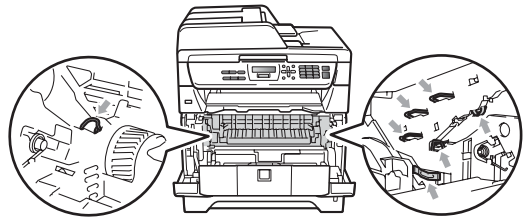

- 3 Push down the blue lock lever and take the toner cartridge out of the drum unit.

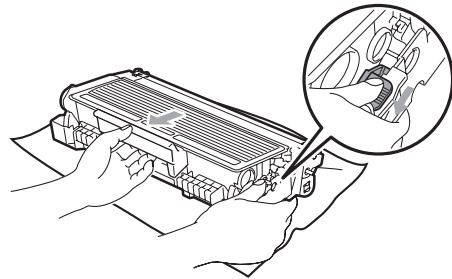

! IMPORTANT

- Handle the toner cartridge carefully. If toner scatters on your hands or clothes, wipe or wash it off with cold water at once.
- To avoid print quality problems, DO NOT touch the shaded parts shown in the illustrations below.

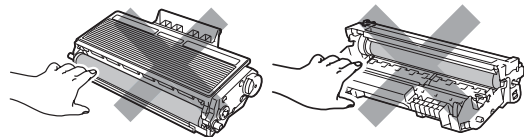

- 4 Put the print sample in front of the drum unit, and find the exact position of the poor print.

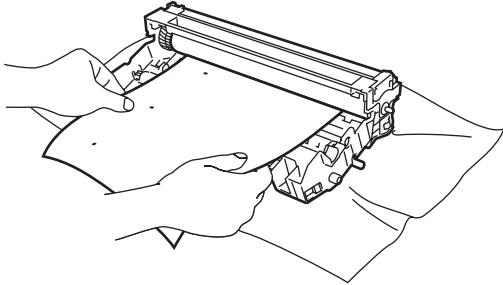

- 5 Turn the drum unit gear by hand while looking at the surface of the OPC drum (1).

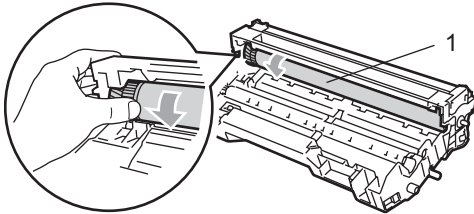

- 6 When you have found the mark on the drum that matches the print sample, wipe the surface of the OPC drum with a dry cotton swab until the dust or glue on the surface comes off.

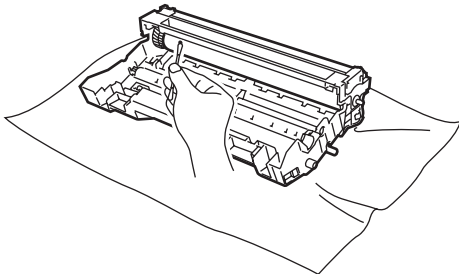

- 7 Put the toner cartridge back into the drum unit until you hear it lock into place. If you put the cartridge in correctly, the blue lock lever will lift automatically.

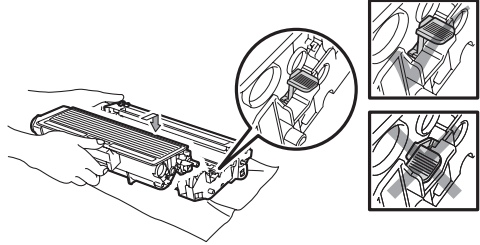

- 8 Put the drum unit and toner cartridge assembly back in the machine.

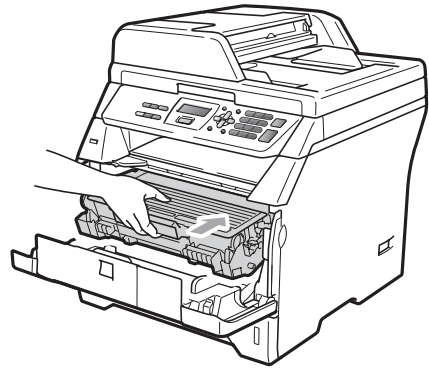

- 9 Close the front cover.
- 10 Plug the machine's power cord back into the electrical socket first and then reconnect all cables. Turn on the machine.

! IMPORTANT

- The drum is photosensitive so **DO NOT** touch it with your fingers.
- **DO NOT** clean the surface of the photosensitive drum with a sharp object.
- **DO NOT** use excessive force when cleaning the drum unit.

Replacing the consumable items

You will need to replace the consumable items when the machine indicates that the life of the consumable is over.

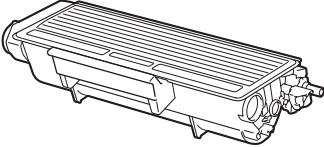
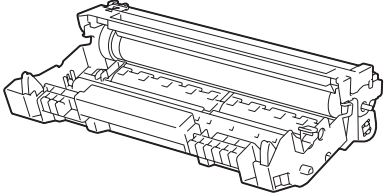
Toner cartridge	Drum unit
	
Order No. TN-3230, TN-3280	Order No. DR-3200

! IMPORTANT

- We recommend placing used consumable items on a sheet of paper to prevent accidentally spilling or scattering the material inside.
- Be sure to reseal the consumable items tightly so that the material inside does not spill.

Note

- Discard used consumable items according to local regulations, keeping it separate from domestic waste. If you have questions, call your local waste disposal office.
- If you use paper that is not a direct equivalent for the recommended paper, the life of consumable items and machine parts may be reduced.

Replacing a toner cartridge

The High Yield toner cartridges can print approximately 8,000 pages¹ and the Standard toner cartridges can print approximately 3,000 pages¹. Actual page count will vary depending on your average type of document (i.e., standard letter, detailed graphics). The machine is supplied with the Starter toner cartridge that will need to be replaced after approximately 2,000 pages. When a toner cartridge is running low, the LCD shows **Toner Low**.

¹ Approx. cartridge yield is declared in accordance with ISO/IEC 19752.



Note

It is a good idea to keep a new toner cartridge ready for use when you see the **Toner Low** warning.

CAUTION

HOT SURFACE

After you have just used the machine, some internal parts of the machine will be extremely hot. To prevent injury, when you open the front or back cover (back output tray) of the machine **DO NOT** touch the shaded parts shown in the illustration. If you do this you may get burned.

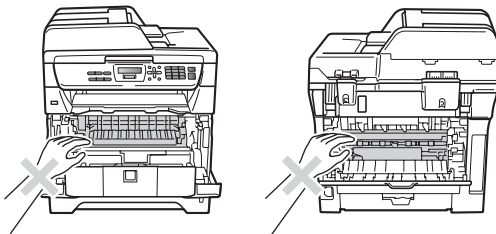

- 1 Press the front cover release button and open the front cover.

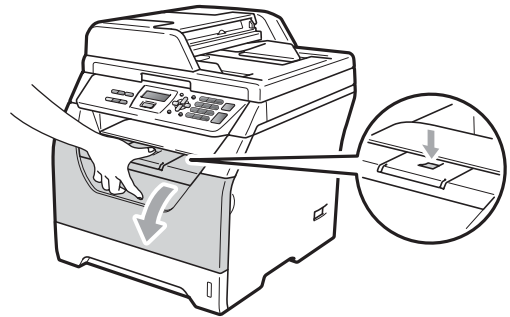

- 2 Slowly take out the drum unit and toner cartridge assembly.

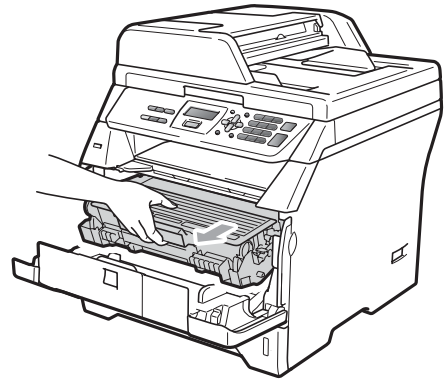

IMPORTANT

- We recommend that you put the drum unit and toner cartridge assembly on a clean, flat surface with a sheet of disposable paper or cloth underneath it in case you accidentally spill or scatter toner.
- To prevent damage to the machine caused by static electricity, **DO NOT** touch the electrodes shown in the illustration.

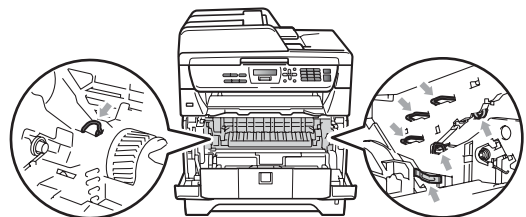

- 3 Push down the blue lock lever and take the used toner cartridge out of the drum unit.

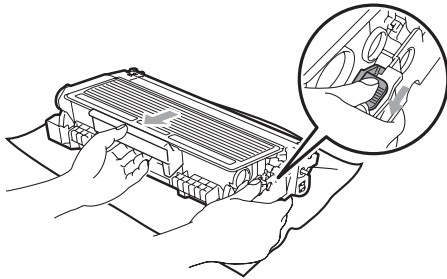

! WARNING

DO NOT put a toner cartridge into a fire. It could explode, resulting in injuries.

! IMPORTANT

- Handle the toner cartridge carefully. If toner scatters on your hands or clothes, wipe or wash it off with cold water at once.
- To avoid print quality problems, DO NOT touch the shaded parts shown in the illustrations.

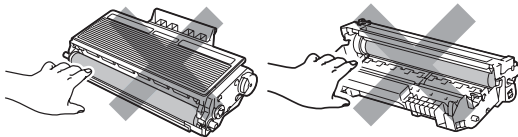

- Brother machines are designed to work with toner of a particular specification and will work to a level of optimum performance when used with genuine Brother toner cartridges (TN-3230/TN-3280). Brother cannot guarantee this optimum performance if toner or toner cartridge of other specifications are used. Brother does not therefore recommend the use of cartridge other than genuine Brother cartridges with

this machine, or the refilling of used cartridge with toner from other sources. If damage is caused to the drum unit or other part of this machine as a result of the use of toner or toner cartridge other than genuine Brother products due to the incompatibility or lack of suitability of those products with this machine, any repairs required as a result may not be covered by the warranty.

- Unpack the toner cartridge just before you put it in the machine. If a toner cartridge is left unpacked for a long time, the toner life will be shortened.
- Be sure to seal up the used toner cartridge tightly in a suitable bag so that toner powder does not spill out of the cartridge.

- 4 Unpack the new toner cartridge. Gently shake from side to side several times to distribute the toner evenly inside the cartridge.

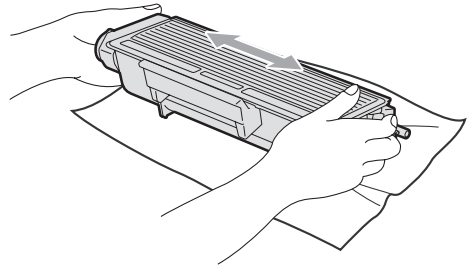

- 5 Pull off the protective cover.

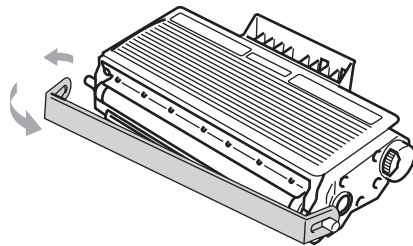

- 6 Put the new toner cartridge firmly into the drum unit until you hear it lock into place. If you put it in correctly, the lock lever will lift automatically.

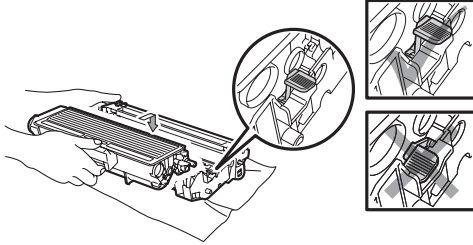

Note

Make sure that you put in the toner cartridge correctly or it may separate from the drum unit.

- 7 Clean the corona wire of the drum unit by gently sliding the blue tab from right to left and left to right several times.

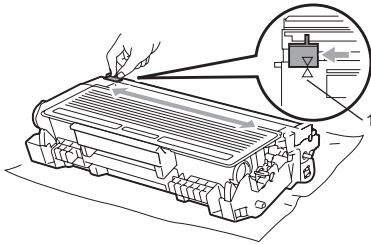

Note

Be sure to return the blue tab to the home position (▲) (1). If you do not, printed pages may have a vertical stripe.

- 8 Put the drum unit and toner cartridge assembly back in the machine.

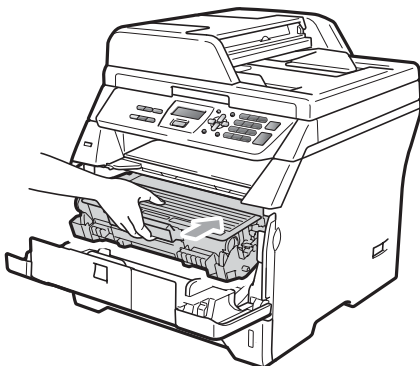

- 9 Close the front cover.



Note

DO NOT turn off the machine or open the front cover until the LCD returns to the standby state.

Replacing the drum unit

The machine uses a drum unit to create print images on paper. If the LCD shows **Replace Drum**, the drum unit is near the end of its life and it is time to buy a new one. Even if the LCD shows **Replace Drum**, you may be able to continue printing without having to replace the drum unit for a while. However, if there is a noticeable deterioration in the output print quality (even before **Replace Drum** appears), then the drum unit should be replaced. You should clean the machine when you replace the drum unit. (See *Cleaning the laser scanner window* on page 79.)

! IMPORTANT

While removing the drum unit, handle it carefully because it may contain toner. If toner scatters on your hands or clothes, wipe or wash it off with cold water at once.

Note

The drum unit is a consumable item, and it is necessary to replace it periodically. There are many factors that determine the actual drum life, such as temperature, humidity, type of paper and how much toner you use for the number of pages per print job. The estimated drum life is approximately 25,000 pages¹. The actual number of pages your drum will print may be significantly less than this estimate. Because we have no control over the many factors that determine the actual drum life, we cannot guarantee a minimum number of pages that will be printed by your drum.

¹ Drum yield is approximate, and may vary by type of use.

! CAUTION

! HOT SURFACE

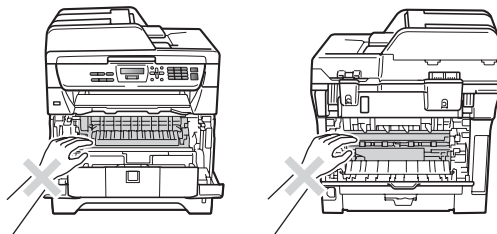

After you have just used the machine, some internal parts of the machine will be extremely hot. To prevent injury, when you open the front or back cover (back output tray) of the machine **DO NOT** touch the shaded parts shown in the illustration. If you do this you may get burned.

- 1 Press the front cover release button and open the front cover.

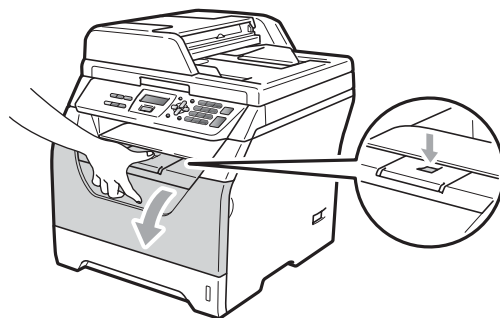

- 2 Slowly take out the drum unit and toner cartridge assembly.

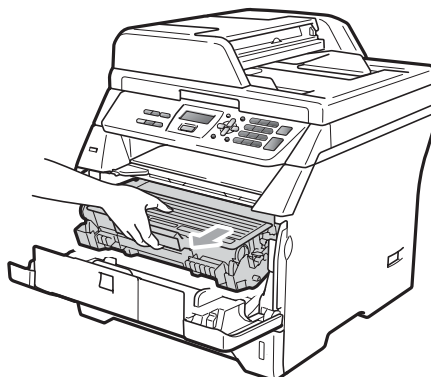

! IMPORTANT

- We recommend that you put the drum unit and toner cartridge assembly on a clean, flat surface with a sheet of disposable paper or cloth underneath it in case you accidentally spill or scatter toner.
- To prevent damage to the machine caused by static electricity, **DO NOT** touch the electrodes shown in the illustration.

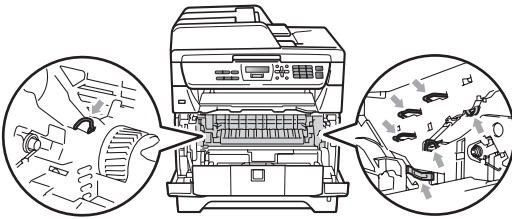

- 3 Push down the blue lock lever and take the toner cartridge out of the drum unit.

! IMPORTANT

- To avoid print quality problems, **DO NOT** touch the shaded parts shown in the illustrations.

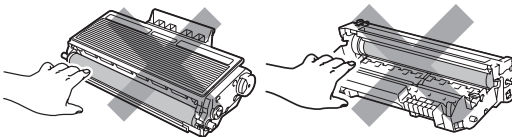

- Wait to unpack a new drum unit until immediately before you put it in the machine. Exposure to direct sunlight or room light may damage the drum unit.
- Be sure to seal up the used drum unit tightly in a bag so that toner powder does not spill out of the unit.

- 4 Unpack the new drum unit.

- 5 Put the toner cartridge firmly into the new drum unit until you hear it lock into place. If you put the cartridge in correctly, the blue lock lever will lift automatically.

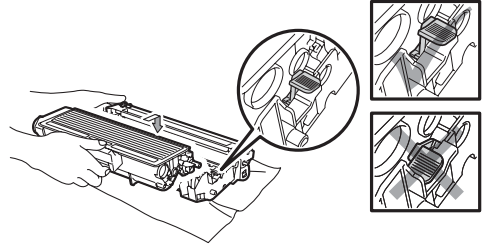

Note

Make sure that you put in the toner cartridge correctly or it may separate from the drum unit.

- 6 Put the new drum unit and toner cartridge assembly in the machine. Do not close the front cover.

- 7 Press **Clear/Back**.

Replace Drum?
1.Yes 2.No

To confirm you are installing a new drum, press **1**.

- 8 When the LCD shows **Accepted**, close the front cover.

Replacing periodic maintenance parts

The periodic maintenance parts will need to be replaced regularly to maintain the print quality. The parts listed below will have to be replaced after printing approximately 50,000 pages for PF Kit MP and 100,000 pages for PF Kit 1, Fuser and Laser. Please call your Brother dealer when the following messages appear on the LCD.

LCD message	Description
Replace PF KitMP	Replace paper feeding kit for MP tray.
Replace PF Kit1	Replace paper feeding kit for Tray 1.
Replace Fuser	Replace fuser unit.
Replace Laser	Replace laser unit.

Machine Information

Checking the Serial Number

You can see the machine's Serial Number on the LCD.

- 1 Press **Menu**, **5**, **3**.
- 2 Press **Stop/Exit**.

Checking the Page Counters

You can see the machine's Page Counters for copies, printed pages, reports and lists or a summary total.

- 1 Press **Menu**, **5**, **4**.
- 2 Press **▲** or **▼** to see **Total**, **List**, **Copy** or **Print**.
- 3 Press **Stop/Exit**.

Checking the remaining life of parts

You can see the remaining life of the machine's drum unit and periodic maintenance parts.

- 1 Press **Menu**, **5**, **6**.
- 2 Press **▲** or **▼** to choose **1.Drum**, **2.Fuser**, **3.Laser**, **4.PF kit MP** or **5.PF kit 1**. Press **OK**.
- 3 Press **Stop/Exit**.

Reset

You can reset all the machine settings back to the settings that were set at the factory.

Brother strongly recommends you perform this operation when you dispose of the machine.



Note

Unplug the interface cable before you reset.

- 1 Press **Menu**, **1**, **7**, **1**.
- 2 Press **1** or **2** to choose 1. *Reset* or 2. *Exit*.
- 3 If you choose 1. *Reset* in step 2, you will be asked to reboot the machine. Press **1** or **2** to choose 1. *Yes* or 2. *No*. If you choose 1. *Yes*, the machine will begin the Reset.

Packing and shipping the machine

⚠ CAUTION

Make sure that the machine has fully cooled down by leaving it disconnected from the power for at least 30 minutes before packing.

When you transport the machine, use the packing materials that came with your machine. If you do not pack the machine correctly, you could void your warranty.

- 1 Turn off the machine.
- 2 Unplug all the cables and AC power cord from the machine.
- 3 Press the front cover release button and open the front cover.
- 4 Take out the drum unit and toner cartridge assembly. Leave the toner cartridge installed in the drum unit.
- 5 Put the drum unit and toner cartridge assembly into a plastic bag and seal the bag.
- 6 Close the front cover.

- 7 Put the styrofoam piece marked "FRONT" into the original carton (1). Wrap the machine in the plastic bag and put it in the original carton (2). Put the drum unit and toner cartridge assembly in as shown below (3). Put the User's Guide (if available) and CD-ROM in the space at the back of the machine (4).

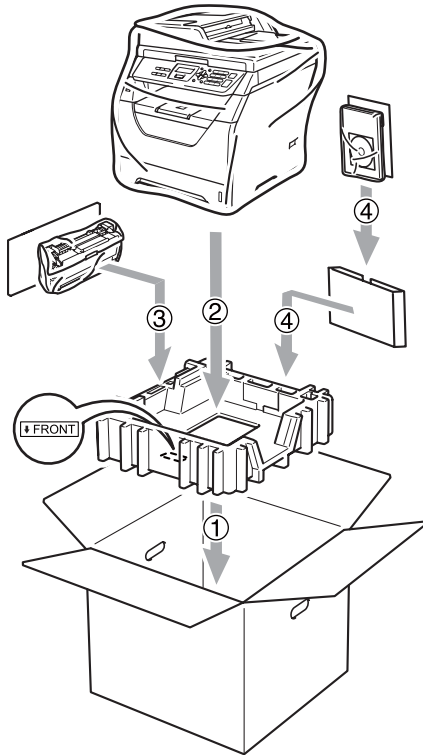

- 8 Take the two styrofoam pieces and match the front of the machine to the "FRONT" mark on one of the styrofoam pieces, and the back of the machine to the "REAR" mark on the other styrofoam piece (5). Coil the cables and place them and the Quick Setup Guide in the spaces provided as shown below (6).

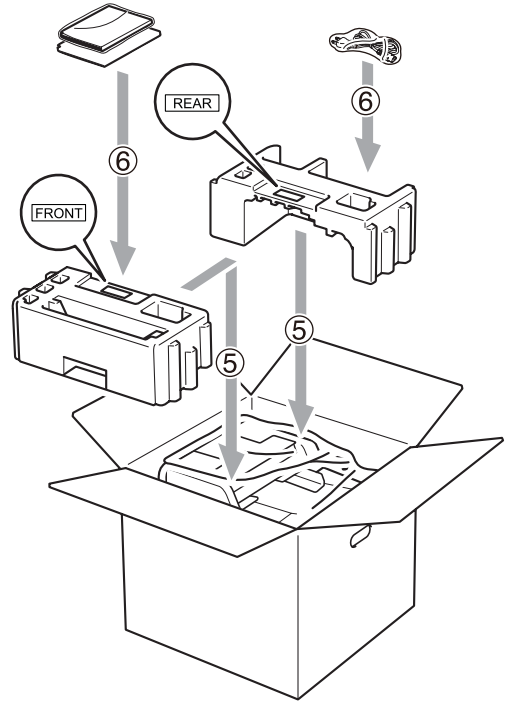

- 9 Close the carton and tape it shut.

On-screen programming

Your machine has been designed to be easy to use. The LCD provides on-screen programming using the menu keys.

We have created step by step on-screen instructions to help you program your machine. Simply follow the steps as they guide you through the menu selections and programming options.

Menu table

You can program your machine by using the *Menu table* on page 95. These pages list the menu selections and options.

Press **Menu** followed by the menu numbers to program your machine.







For example, to set *Beeper* volume to *Low*:

- 1 Press **Menu**, **1**, **2**.
- 2 Press ▲ or ▼ to choose *Low*.
- 3 Press **OK**.

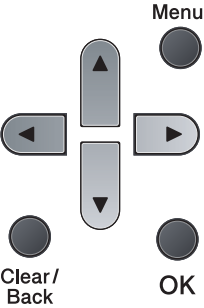
Memory storage

Your menu settings are stored permanently, and in the event of a power failure will *not* be lost. Temporary settings (for example, *Contrast*) *will* be lost.

Menu keys

	
<p>Menu</p> 	<p>Access the menu.</p>
 <p>OK</p>	<p>Go to the next menu level. Accept an option.</p>
 <p>Clear/ Back</p>	<p>Exit the menu by pressing repeatedly. Go back to the previous menu level.</p>
	<p>Scroll through the current menu level.</p>
	<p>Go back to the previous menu level or forward to the next menu level.</p>
<p>Stop/Exit</p> 	<p>Exit the menu.</p>

How to access the menu mode

- 1 Press **Menu**.
- 2 Choose an option.
 - Press **1** for General Setup menu.
 - Press **2** for Copy menu.
 - Press **3** for Printer menu.
 - Press **4** for USB Direct I/F menu.
 - Press **5** for Machine Info. menu.

You can also scroll through each menu level by pressing **▲** or **▼** for the direction you want.
- 3 Press **OK** when the option you want appears on the LCD.
The LCD will then show the next menu level.
- 4 Press **▲** or **▼** to scroll to your next menu selection.
- 5 Press **OK**.
When you have finished setting an option, the LCD will show *Accepted*.
- 6 Press **Stop/Exit** to exit Menu mode.

Menu table

The factory settings are shown in Bold with an asterisk.

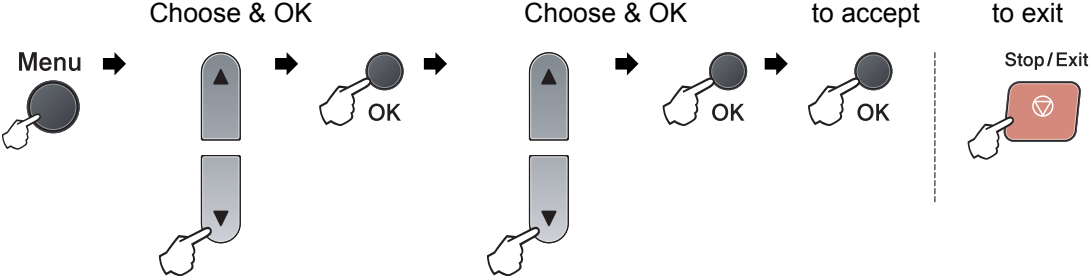

Main Menu	Submenu	Menu Selections		Options	Descriptions	Page
1.General Setup	1.Paper	1.Paper Type	1.MP Tray	Thin Plain* Thick Thicker Transparency Recycled Paper	Sets the type of paper in the MP tray.	20
			2.Tray#1	Thin Plain* Thick Thicker Transparency Recycled Paper	Sets the type of paper in the paper tray.	20
		2.Paper Size	1.MP Tray	A4* Letter Legal Executive A5 A5 L A6 B5 B6 Folio Any	Sets the size of the paper in the MP tray.	20



Main Menu	Submenu	Menu Selections		Options	Descriptions	Page
1.General Setup (Continued)	1.Paper (Continued)	2.Paper Size (Continued)	2.Tray#1	A4* Letter Executive A5 A5 L A6 B5 B6	Sets the size of the paper in the paper tray.	20
	2.Beeper	—		Off Low Med* High	Adjusts the ring volume.	22
	3.Ecology	1.Toner Save		On off*	Increases the page yield of the toner cartridge.	22
		2.Sleep Time		Range varies depending on model. 005Min*	Conserves power.	22
	4.Tray Use	1.Copy		Tray#1 Only MP Only MP>T1* T1>MP	Selects the tray that will be used for Copy mode.	21
		2.Print		Tray#1 Only MP Only MP>T1* T1>MP	Selects the tray that will be used for PC print.	21
	5.LCD Contrast	—		-□□□■+ -□□□■+ -□□■□+* -■□□□+ -■□□□+	Adjusts the contrast of the LCD.	23

Main Menu	Submenu	Menu Selections	Options	Descriptions	Page	
1.General Setup (Continued)	6.Document Scan	1.Glass ScanSize	A4* Letter	Adjusts the scan area of the scanner glass to the size of the document. You can set your own default settings of the data compression rate.	See <i>Software User's Guide</i> on the CD-ROM.	
		2.File Size	1.Color			Small Middle* Large
			2.Gray			Small Middle* Large
	7.Reset	1.All Settings	1.Reset 2.Exit	Restore all the machine settings to factory default.	91	
	0.Local Language	—	(Choose your language.)	Allows you to change the LCD language for your country.	See <i>Quick Setup Guide</i> .	

Main Menu	Submenu	Menu Selections	Options	Descriptions	Page
2.Copy	1.Quality	—	Text Photo Auto*	You can choose the Copy resolution for your type of document.	29
	2.Brightness	—	-□□□■+ -□□□□+ -□■□□+* -□■□□+ -■□□□+	Adjust the brightness for copies.	29
	3.Contrast	—	-□□□■+ -□□□□+ -□■□□+* -□■□□+ -■□□□+	Adjust the contrast for copies.	29
3.Printer	1.Emulation	—	Auto (EPSON)* Auto (IBM) HP LaserJet BR-Script 3 Epson FX-850 IBM Proprinter	Chooses the emulation mode.	See Software User's Guide on the CD-ROM.
	2.Print Options	1.Internal Font	1.HP LaserJet 2.BR-Script 3	Prints a list of the machine's internal fonts.	
		2.Configuration	—	Prints a list of the machine's printer settings.	
		3.Test Print	—	Prints a test page.	
	3.Duplex	—	Off* On (Long Edge) On (Short Edge)	Enables or disables duplex printing. You can also choose long edge or short edge duplex printing.	
4.Reset Printer	—	1.Reset 2.Exit	Restores the printer settings to the original factory default settings.		

Main Menu	Submenu	Menu Selections	Options	Descriptions	Page
4.USB Direct I/F	1.Direct Print	1.Paper Size	A4* Letter Legal Executive A5 A5 L A6 B5 B6 Folio	Sets the paper size when printing directly from the USB flash memory drive. You can choose Legal and Folio for MP Tray only.	37
		2.Media Type	Thin Plain* Thick Thicker Recycled Paper	Sets the media type when printing directly from the USB flash memory drive.	37
		3.Multiple Page	1in1* 2in1 4in1 9in1 16in1 25in1 1 in 2x2 pages 1 in 3x3 pages 1 in 4x4 pages 1 in 5x5 pages	Sets the page style when printing multiple pages directly from the USB Flash memory drive.	37
		4.Orientation	Portrait* Landscape	Sets the page orientation when printing directly from the USB Flash memory drive.	37
		5.Collate	On* Off	Enables or disables the page collation when printing directly from the USB Flash memory drive.	37
		6.Print Quality	Normal* Fine	Sets the print quality option when printing directly from the USB Flash memory drive.	37

Main Menu	Submenu	Menu Selections	Options	Descriptions	Page
4.USB Direct I/F (Continued)	1.Direct Print (Continued)	7.PDF Option	Document* Document&Markup Document&Stamps	Sets the PDF option whether to print comments (Markup) or stamps in the PDF file along with the text.	37
		8.Index Print	Simple* Details	Sets the index print option, simple format or details.	37
	2.Scan to USB	1.Resolution	Color 100 dpi* Color 200 dpi Color 300 dpi Color 600 dpi Gray 100 dpi Gray 200 dpi Gray 300 dpi B&W 200 dpi B&W 200x100 dpi	Sets the resolution to send the scanned data to USB Flash memory drive.	See Software User's Guide on the CD-ROM.
		2.File Name	—	Enter the file name of the scanned data.	
5.Machine Info.	1.Date&Time	—	—	Allows the machine to name files created when using the scan to USB feature.	See Quick Setup Guide.
	2.Auto Daylight	—	On* Off	Changes for Daylight Savings Time automatically.	23
	3.Serial No.	—		You can check the serial number of your machine.	90
	4.Page Counter	—	Total List Copy Print	You can check the number of total pages the machine has printed during its life.	90
	5.User Settings	—		Lists your settings.	23
	6.Parts Life	1.Drum 2.Fuser 3.Laser 4.PF kit MP 5.PF kit 1	—	You can check the percentage of a machine part's life that remains available.	90

Entering text

When setting certain menu selections, you will need to type text characters. The dial pad keys have letters printed on them. The keys: **#** and ***** do *not* have printed letters because they are used for special characters.

Press the appropriate dial pad key the required number of times to access the characters below:

Press Key	one time	two times	three times	four times	five times
2	A	B	C	2	A
3	D	E	F	3	D
4	G	H	I	4	G
5	J	K	L	5	J
6	M	N	O	6	M
7	P	Q	R	S	7
8	T	U	V	8	T
9	W	X	Y	Z	9

Inserting spaces

To enter a space in a number, press **▶** once between numbers. To enter a space in a name, press **▶** twice between characters.

Making corrections

If you entered a letter incorrectly and want to change it, press **◀** to move the cursor to the incorrect character, and then press **Clear/Back**.

Repeating letters

To enter a character on the same key as the previous character, press **▶** to move the cursor right before pressing the key again.

Special characters and symbols

Press ***** or **#**, then press **◀** or **▶** to move the cursor to the symbol or character you want. Press **OK** to choose it. The symbols and characters below will appear depending on your menu selection.

Press ***** for ! # \$ % & ' () -
 Press **#** for @ ^ _ ` { } ~
 Press **0** for 0

General

Printer Type	Laser	
Print Method	Electrophotography by semiconductor laser beam scanning	
Memory Capacity	64 MB	
LCD (liquid crystal display)	16 characters × 2 lines	
Power Source	220 - 240V 50/60Hz	
Power Consumption	Peak:	1080 W
	Copying:	Average 570 W ¹
	Sleep:	Average 9 W
	Standby:	Average 80 W

¹ When making a copy from one sheet

Dimensions

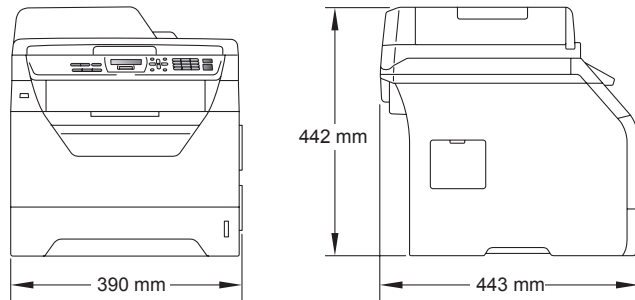

Weight

With Drum/Toner Unit: 15.3 kg

Noise level**Sound power**

Operating (Copying)¹: LwAd = 6.58 Bell (A)

Office equipment with LwAd > 6.30 Bell (A) is not suitable for use in room where people do primarily intellectual work. Such equipment should be placed in separate rooms because of the noise emission.

Standby: LwAd = 4.09 Bell (A)

Sound pressure

Operating (Copying): LPAM = 56 dB (A)

Standby: LPAM = 30 dB (A)

¹ Measured in accordance with ISO9296.

Temperature

Operating: 10 to 32.5°C

Storage: 5 to 35°C

Humidity

Operating: 20 to 80% (without condensation)

Storage: 10 to 90% (without condensation)

ADF (automatic document feeder)

Up to 20 pages (Staggered) [80 g/m²]

Recommended Environment for Best Results

Temperature: 20 to 30°C

Humidity: 50% - 70%

Paper: Xerox Premier TCF 80 g/m² or
Xerox Business 80 g/m²

Paper Tray

250 Sheets (80 g/m²)

Print media

Paper Input

Paper Tray

- Paper Type: Thin paper, Plain paper, Bond paper and Transparencies ¹ or Recycled paper
- Paper Size: A4, Letter, B5 (ISO), A5, A5 (Long Edge), B6 (ISO), A6 and Executive
- Paper Weight: 60 to 105 g/m²
- Maximum Paper Tray Capacity: Up to 250 sheets of 80 g/m² Plain paper

Multi-purpose tray (MP tray)

- Paper Type: Thin paper, Plain paper, Thick paper, Bond paper, Transparencies ¹, Recycled paper, Envelopes or Labels ¹
- Paper Size: Width: 69.8 to 216 mm
Length: 116 to 406.4 mm
- Paper Weight: 60 to 163 g/m² ²
- Maximum Multi-purpose tray Capacity: Up to 50 sheets of 80 g/m² Plain paper
Up to 3 envelopes

¹ For transparencies or labels, we recommend removing printed pages from the output paper tray immediately after they exit the machine to avoid the possibility of smudging.

² 60 to 105 g/m² for duplex print.

Paper Output

- Output Tray: Up to 150 sheets (face-down print delivery to the output paper tray)
- Back Output Tray: One sheet (face-up print delivery to the back output tray)

Duplex Printing

- Paper Size: A4
- Paper Weight: 60 to 105 g/m²
- Manual Duplex: Yes
- Automatic Duplex: Yes

Copy

Colour/Monochrome	Monochrome
Document Size	ADF Width: 148 to 215.9 mm
	ADF Length: 148 to 355.6 mm ¹
	Scanner Glass Width: Max. 215.9 mm
	Scanner Glass Length: Max. 297 mm
Copy Width	Max. 210 mm
Multiple Copies	Stacks or Sorts up to 99 pages
Reduce/Enlarge	25% to 400% (in increments of 1%)
Resolution	Max. 1200 × 600 dpi
First Copy Out Time	Less than 10.5 seconds ² (from READY mode)

¹ 5 sheet ADF input limit when using sheets longer than A4.

² The first copy out time may vary depending on scanner lamp warm up time.

Scan

Colour/Monochrome	Yes/Yes
TWAIN Compliant	Yes (Windows® 2000 Professional/XP/ XP Professional x64 Edition/Windows Vista®) Mac OS X 10.3.9 or greater ¹
WIA Compliant	Yes (Windows® XP/Windows Vista®)
Colour Depth	24 bit colour
Resolution	Up to 19200 × 19200 dpi (interpolated) ² Up to 600 × 2400 dpi (optical) ² (From Scanner Glass) Up to 600 × 600 dpi (optical) ² (From ADF)
Document Size	ADF Width: 148.0 to 215.9 mm ADF Length: 148.0 to 355.6 mm ³ Scanner Glass Width: Max. 215.9 mm Scanner Glass Length: Max. 297 mm
Scanning Width	Max. 212 mm
Greyscale	8 bit levels

¹ For the latest driver updates, visit us at <http://solutions.brother.com/>.

² Maximum 1200 × 1200 dpi scanning with the WIA driver in Windows® XP/Windows Vista® (resolution up to 19200 × 19200 dpi can be chosen by using the Brother scanner utility).

³ 5 sheet ADF input limit when using sheets longer than A4.

Print

Emulations	PCL6, BR-Script3 (PostScript [®] 3™), IBM Pro-Printer XL, Epson FX-850
Printer Driver	Host-Based Driver for Windows [®] 2000 Professional/ XP/XP Professional x64 Edition/Windows Vista [®]
	BR-Script3 (PPD file) for Windows [®] 2000 Professional/ XP/XP Professional x64 Edition/Windows Vista [®]
	Macintosh Printer Driver for Mac OS X 10.3.9 or greater ¹ BR-Script3 (PPD file) for Mac OS X 10.3.9 or greater ¹
Resolution	1200 dpi ² , HQ1200 (2400 × 600 dpi), 600 dpi, 300 dpi
Print Speed for Simplex	Up to 28 pages/minute (A4 size) ³
Print Speed for Duplex Printing	Up to 13 sides/minute (A4 size)
First Print Out Time	Less than 8.5 seconds (from the READY state and standard tray)

¹ For the latest driver updates, visit us at <http://solutions.brother.com/>.

² Using 1200 dpi setting (1200 x 1200 dpi) the print speed will be slower.

³ The print speed may change depending on the type of document you print.

Interfaces

USB Use a USB 2.0 interface cable (type A/B) that is no longer than 2 m. ¹ ²

¹ Your machine has a Hi-Speed USB 2.0 interface. The machine can also be connected to a computer that has a USB 1.1 interface.

² Third party USB ports are not supported.

Direct Print feature

Compatibility PDF version 1.7 ¹, JPEG, Exif + JPEG, PRN (created by Brother printer driver), TIFF (scanned by all Brother MFC or DCP models), PostScript®3™ (created by Brother BR-Script 3 printer driver), XPS version 1.0.

¹ PDF data including a JBIG2 image file, a JPEG2000 image file or transparency files are not supported.

Computer requirements

Minimum System Requirements and Supported PC Software Functions								
Computer Platform & Operating System Version		Processor Minimum Speed	Minimum RAM	Recommended RAM	Hard Disk Space to install		Supported PC Software Functions	PC Interface ³
					For Drivers	For Applications		
Windows® Operating System ¹	Windows® 2000 Professional ⁴	Intel® Pentium® II or equivalent	64 MB	256 MB	150 MB	310 MB	Printing, Scanning	USB
	Windows® XP Home® ^{2 4}		128 MB					
	Windows® XP Professional ^{2 4}	64-bit (Intel® 64 or AMD64) supported CPU	256 MB	512 MB				
	Windows® XP Professional x64 Edition	Intel® Pentium® 4 or equivalent 64-bit (Intel® 64 or AMD64) supported CPU	512 MB	1GB	500 MB	500 MB		
Macintosh Operating System	Mac OS X 10.3.9 - 10.4.3	PowerPC G4/G5, PowerPC G3 350MHz	128MB	256MB	80 MB	400 MB	Printing, Scanning	USB
	Mac OS X 10.4.4 or greater	PowerPC G4/G5, Intel® Core™ Processor	512MB	1GB				

¹ Internet Explorer 5.5® or greater

² Maximum 1200 x 1200 dpi scanning with the WIA driver in Windows® XP/Windows Vista® (resolution up to 19200 x 19200 dpi can be chosen by using the scanner utility.)

³ Third party USB ports are not supported.

⁴ PaperPort™ 11SE supports Microsoft® SP4 or higher for Windows® 2000 and SP2 or higher for XP.

For the latest driver updates, visit us at <http://solutions.brother.com/>.

All trademarks, brand and product names are property of their respective companies.

Consumable items

Toner Cartridge Life	Starter Toner Cartridge:	Approx. 2,000 pages (A4) ¹
	Standard Toner Cartridge:	
	TN-3230:	Approx. 3,000 pages (A4) ¹
	High-Yield Toner Cartridge:	
Drum Unit	TN-3280:	Approx. 8,000 pages (A4) ¹
	DR-3200:	Approx. 25,000 pages (A4) ²

¹ Approx. cartridge yield is declared in accordance with ISO/IEC 19752.

² Drum yield is approximate, and may vary by type of use.

This is a comprehensive list of features and terms that appear in Brother manuals. Availability of these features depends on the model you purchased.

ADF (automatic document feeder)

The document can be placed in the ADF and scanned one page at a time automatically.

Beeper Volume

Volume setting for the beep when you press a key or make an error.

Cancel Job

Cancels a programmed print job and clears the machine's memory.

Contrast

Setting to compensate for dark or light documents, by making copies of dark documents lighter and light documents darker.

Fine resolution

Resolution is 203 × 196 dpi. It is used for small print and graphs.

Greyscale

The shades of grey available for copying photographs.

LCD (liquid crystal display)

The display screen on the machine that shows interactive messages during On-Screen Programming and shows the date and time when the machine is idle.

Menu mode

Programming mode for changing your machine's settings.

OCR (optical character recognition)

The bundled ScanSoft™ PaperPort™ 11SE with OCR or Presto! PageManager software application converts an image of text to text you can edit.

Resolution

The number of vertical and horizontal lines per inch.

Scanning

The process of sending an electronic image of a paper document into your computer.

User Settings List

A printed report that shows the current settings of the machine.

G

Index

A		D	
<hr/>		<hr/>	
ADF (automatic document feeder)		Data LED	6
using	18	Direct print	36
Apple Macintosh		Direct key	37
See Software User's Guide on the		specification	108
CD-ROM.		Document	
C		how to load	18, 19
<hr/>		jam	70
Cancelling		Drum unit	
print jobs	7	checking (remaining life)	90
Cleaning		cleaning	81, 82
corona wire	81	replacing	88
drum unit	82	Duplex (2-sided)	
laser scanner window	79	copying	32
scanner glass	78	printing	
Consumable items	84	from USB flash memory drive	37
Control panel overview	6	Duplex key (2-sided)	32
ControlCenter2 (for Macintosh)		E	
See Software User's Guide on the		<hr/>	
CD-ROM.		Enlarge/Reduce key	27
ControlCenter3 (for Windows®)		Envelopes	10, 13, 15, 16
See Software User's Guide on the		Error messages on LCD	66
CD-ROM.		No Paper	67
Copy		Out of Memory	68
contrast	26, 30	Print Unable XX	68
duplex	32	Scan Unable XX	68
Enlarge/Reduce key	27	Unable to Scan	69
enter copy mode	26	G	
keys	7, 27	<hr/>	
multiple	26	Greyscale	106
N in 1 (page layout)	30	H	
out of memory	33	<hr/>	
quality	29	HELP	
single	26	LCD messages	93
sort (ADF only)	29	Menu Table	93, 95
temporary settings	27	using menu keys	93
tray selection	31	J	
using ADF	29	<hr/>	
using scanner glass	30	Jams	
		document	70
		paper	71
		Job Cancel key	7

L

Labels	10, 13, 14, 17
LCD (liquid crystal display)	6, 93
contrast	23

M

Machine information	
checking remaining life of drum unit and periodic maintenance parts	90
Data LED	8
page counts	90
Macintosh	
See Software User's Guide on the CD-ROM.	
Maintenance, routine	77
checking the remaining life of drum unit	90
replacing	
drum unit	88
toner cartridge	85
Memory	
adding SO-DIMM (option)	53
installing	53
storage	93
Menu Table	93, 95
using menu keys	93
Mode, entering	
copy	26
scan	6

N

N in 1 (page layout)	30
----------------------------	----

O

Out of Memory message	33, 38, 68
-----------------------------	------------

P

Packing and shipping the machine	91
Page layout (N in 1)	30
Paper	13, 104
how to load	9
jam	71
recommended	13, 14
size	13, 20

size of document	105, 106
tray capacity	14
type	13, 20
PaperPort™ 11SE with OCR	
See Software User's Guide on the CD-ROM and Help in the PaperPort™ 11SE application to access How-to-Guides.	
Power failure	93
Print	
difficulties	56
drivers	107
Job Cancel key	7
keys	7
paper jams	71
quality	58, 59
resolution	107
Secure key	7
specifications	107
Printing	
See Software User's Guide on the CD-ROM.	
Programming your machine	93

Q

Quality	
copying	29
printing	58, 59

R

Reducing	
copies	27
Replacing	
drum unit and periodic maintenance parts	88
toner cartridge	85
Resolution	
copy	105
print	107
scan	106

S

Safety instructions	49
Scanner glass	
using	19
Scanning	
See Software User's Guide on the CD-ROM.	

Secure key	7
Security	
Secure key	7
Serial number	
how to find.....	See inside front cover
Shipping the machine	91
Sleep time	22
Sort	29
Status LED	8

T

Temporary copy settings	27
Text, entering	101
Toner cartridge, replacing	85
Toner save	22
Transparencies	9, 10, 13
Tray selection	31
Tray use, setting	
copy	21
print	21
Troubleshooting	55
document jam	70
error messages on LCD	66
if you are having difficulty	
copy quality	55
Menu access	55
paper handling	58
print quality	58, 59
printing	56
scanning	57
software	57
maintenance messages on LCD	66
paper jam	71

V

Volume, setting	
beeper	22

W

Windows®	
See Software User's Guide on the CD-ROM.	

brother[®]

The machine is approved for use in the country of purchase only, local Brother companies or their dealers will only support machines purchased in their own countries.