



Brother Color Laser Printer **SERVICE MANUAL**

**MODEL:
DCP-9040CN/9042CDN
MFC-9440CN/9450CDN**



Read this manual thoroughly before carrying out any maintenance work.
Keep this manual in a convenient place for quick and easy reference at all times.

© Copyright Brother Industries, Ltd. 2007

Compilation and Publication:

This manual has been compiled and published, under the supervision of Brother Industries Ltd., covering the latest product descriptions and specifications. The contents of this manual and the specifications of this product are subject to change without notice. Brother reserves the right to make changes without notice in the specifications and materials contained herein and shall not be responsible for any damages (including consequential) caused by reliance on the materials presented, including but not limited to typographical and other errors relating to the publication. This product is designed for use in a professional environment.

PREFACE

This service manual contains basic information required for after-sales service of the color laser multi function center (hereinafter referred to as "the machine"). This information is vital to the service personnel to maintain the high printing quality and performance of the machine.

This service manual covers the **DCP-9040CN/9042CDN/ MFC-9440CN/9450CDN** machines.

This manual consists of the following chapters:

CHAPTER 1: TROUBLESHOOTING

Details of error messages and codes that the incorporated self-diagnostic functions of the machine will display if any error or malfunction occurs. If any error message appears, refer to this chapter to find which parts should be checked or replaced.

The latter half of this chapter provides sample problems that could occur in the main sections of the machine and related troubleshooting procedures.

CHAPTER 2: PERIODICAL MAINTENANCE

Details of consumable parts and periodical maintenance parts. This chapter also covers procedures for disassembling and assembling periodical maintenance parts.

CHAPTER 3: DISASSEMBLY AND ASSEMBLY

Details of procedures for disassembling and assembling the machine together with related notes. The disassembly order flow provided enables you to see at a glance the quickest way to get to parts involved.

At the start of a disassembly job, you can check the disassembly order flow that guides you through a shortcut to get to the object parts.

This chapter also covers screw tightening torques and lubrication points to which the specified lubrications should be applied during assembly of the machine.

CHAPTER 4: ADJUSTMENTS AND UPDATING OF SETTINGS, REQUIRED AFTER PARTS REPLACEMENT

Details of adjustments and updates of settings, which are required if the main PCB and some other parts of the machine have been replaced. This chapter also covers how to update the firmware.

CHAPTER 5: SERVICE FUNCTIONS

Describes the maintenance mode which is exclusively designed for the purpose of checking the settings and making any adjustments using the control panel.

This chapter also covers hidden function menus, which activate settings and functions or reset the parts life.

CHAPTER 6: CIRCUIT DIAGRAMS, WIRING DIAGRAM

Provides Circuit Diagrams and Wiring Diagrams for the connections of the PCBs.

APPENDIX 1: WORKER SWITCH SETTINGS (WSW)

Describes the functions of the worker switches, which can be divided into two groups: one is for customizing preferences designed for the destination and the other is for modifying preferences that match the machine to the environmental conditions. Use the latter group if the machine malfunctions due to mismatching.

APPENDIX 2: DELETION OF PERSONAL INFORMATION

Provides instructions on how to delete personal information recorded in the machine.

APPENDIX 3: SERIAL NUMBERING SYSTEM

APPENDIX 4: SCREW CATALOGUE

APPENDIX 5: HOW TO MAKE THE DRUM UNIT REMOVE SHEET

APPENDIX 6: REFERENCES

Information in this manual is subject to change due to improvement or redesign of the product. All relevant information in such cases will be supplied in service information bulletins (Technical Information).

A thorough understanding of this machine, based on information in this service manual and service information bulletins, is required for maintaining its print quality performance and for improving the practical ability to find the cause of problems.

There is the service reference manual as well. This service reference manual contains "SPECIFICATIONS", "THEORY OF OPERATION", "TONER CARTRIDGE WEIGHT INFORMATION", "REFERENCES" and "GLOSSARY".

TABLE OF CONTENTS

REGULATION.....	VIII
SAFETY INFORMATION.....	XII
CHAPTER 1 TROUBLESHOOTING	1-1
1. INTRODUCTION	1-1
1.1 Precautions	1-1
1.2 Initial Check.....	1-1
2. ERROR CODES	1-3
2.1 Error Indication.....	1-3
2.2 Error Cause and Remedy	1-5
2.2.1 Recoverable Error by User Check.....	1-5
2.2.2 Service Call Error.....	1-8
3. PAPER FEEDING PROBLEMS.....	1-39
3.1 No Feeding.....	1-39
3.2 Double Feeding.....	1-39
3.3 Paper Jam.....	1-40
3.4 Dirt on Paper	1-41
3.5 Wrinkles.....	1-41
4. IMAGE DEFECT TROUBLESHOOTING.....	1-42
4.1 Image Defect Examples	1-42
4.2 Diameter of Rollers	1-43
4.3 Troubleshooting Image Defect.....	1-43
5. SOFTWARE SETTING PROBLEMS.....	1-60
6. NETWORK PROBLEMS	1-61
7. TROUBLESHOOTING OF THE COMMUNICATIONS ERRORS.....	1-62
8. TROUBLESHOOTING OF THE CONTROL PANEL.....	1-66
9. TROUBLESHOOTING OF FAX FUNCTIONS.....	1-68
10. OTHERS PROBLEMS.....	1-72
CHAPTER 2 PERIODICAL MAINTENANCE.....	2-1
1. CONSUMABLE PARTS.....	2-1
2. PERIODICAL REPLACEMENT PARTS	2-4
2.1 Periodical Replacement Parts.....	2-4
2.2 Procedures to Replace Periodical Replacement Parts.....	2-5
2.2.1 Fuser Unit & Fuser Filter Frame ASSY.....	2-5
2.2.2 Laser Unit.....	2-9

2.2.3 Paper Feeding Kit (PF Kit1, PF Kit2)	2-30
2.2.4 MP Paper Feeding Kit (PF Kit MP)	2-35
2.3 Parts Life Reset Function	2-40

CHAPTER 3 DISASSEMBLY AND ASSEMBLY..... 3-1

1. SAFETY PRECAUTIONS.....	3-1
2. PACKING	3-2
3. SCREW TORQUE LIST	3-3
4. LUBRICATION	3-7
5. OVERVIEW OF GEARS.....	3-13
6. HARNESS ROUTING.....	3-18
7. DISASSEMBLY FLOW.....	3-28
8. DISASSEMBLY PROCEDURE	3-29
8.1 Paper Tray.....	3-29
8.2 DX Feed ASSY (DCP-9042CDN/ MFC-9450CDN only).....	3-31
8.3 MP Cover ASSY/ MP Paper Guide ASSY	3-32
8.4 MP Lift Arm 2/ MP Roller Holder ASSY	3-35
8.5 Fuser Unit/ Toner Filter Frame ASSY	3-37
8.6 Back Cover Upper	3-39
8.7 Paper Eject ASSY DX/SX	3-40
8.8 Back Cover ASSY	3-43
8.9 Paper Guide DX/ HV TR Top Cover	3-44
8.10 Transfer HVPS PCB Unit	3-45
8.11 Registration-mark Sensor PCB ASSY 1, 2/ Density Sensor/ Registration Relay PCB ASSY/ Transfer HVPS PCB ASSY	3-46
8.12 Side Cover L ASSY	3-52
8.13 Side Plate LB.....	3-53
8.14 Drum Unit Fan (OPC).....	3-54
8.15 Side Cover R ASSY	3-55
8.16 Paper Stopper	3-56
8.17 Driver PCB ASSY.....	3-57
8.18 Document Scanner Unit.....	3-59
8.19 ADF Unit.....	3-62
8.20 Panel Unit.....	3-75
8.21 NCU PCB ASSY (MFC-9440CN/ 9450CDN only).....	3-79
8.22 Joint Cover ASSY.....	3-81
8.23 Roller Holder ASSY.....	3-90
8.24 Paper Feed Frame Unit/ T1 PE/Edge Sensor PCB ASSY	3-91
8.25 Belt Cleaner Release Sensor PCB ASSY.....	3-99
8.26 THM/HUM Sensor Holder ASSY	3-100

8.27	Release Rack.....	3-102
8.28	Front Door Unit ASSY	3-103
8.29	Harness Cover MP	3-106
8.30	Front Door Sub.....	3-107
8.31	EL Electrode Spring L/R.....	3-108
8.32	Hook Cover/ Front Cover Release Button/ Button Spring/ Front Door Main	3-109
8.33	Hook Shaft/ Hook/ Hook Spring	3-111
8.34	Engine PCB ASSY	3-112
8.35	Main PCB ASSY/ Ground Plate/ Ground Spring Plate	3-113
8.36	Waste Toner Near/Full Sensor ASSY	3-115
8.37	Laser Unit/ Hook Slope	3-117
8.38	Develop Drive Motor ASSY	3-119
8.39	Drum Drive ASSY/ Drum Phase Sensor PCB ASSY 1, 2.....	3-124
8.40	Drive Frame Unit ASSY	3-128
8.41	Paper Feed/Belt Cleaner Motor ASSY.....	3-129
8.42	Develop Release Sensor PCB ASSY	3-130
8.43	Develop Press Drive L ASSY.....	3-130
8.44	Front Cover Interlock Switch ASSY	3-133
8.45	Toner Sensor PCB ASSY K, Y, M, C (TE/NEW)	3-134
8.46	New Toner Actuator/ New Toner Actuator Spring	3-138
8.47	Side Plate R ASSY.....	3-139
8.48	Drum Lock Lever L.....	3-140
8.49	Drum Lock Lever R	3-141
8.50	Charge HVPS PCB ASSY.....	3-142
8.51	Toner LED PCB ASSY	3-144
8.52	Fuser Unit Fan (FU)	3-145
8.53	LVPS Fan (PS).....	3-145
8.54	Air Intake Fan (AIR)	3-146
8.55	PS PCB Unit.....	3-147
8.56	Belt Unit Drive Motor ASSY	3-151
9.	DISASSEMBLY PROCEDURE (LT-100CL) (MFC-9440CN/ 9450CDN ONLY).....	3-154
9.1	LT Paper Tray	3-154
9.2	LT Cover Rear.....	3-158
9.3	LT Cover Left.....	3-159
9.4	LT Cover Right	3-160
9.5	LT Relay PCB ASSY	3-161
9.6	LT Solenoid ASSY.....	3-162
9.7	Collar 6	3-163
9.8	Cassette Switch ASSY.....	3-163
9.9	LT Paper Feed Frame Unit	3-165

CHAPTER 4 ADJUSTMENTS AND UPDATING OF SETTING, REQUIRED AFTER PARTS REPLACEMENT 4-1

- 1. IF YOU REPLACE THE MAIN PCB 4-1
- 2. IF YOU REPLACE THE ENGINE PCB..... 4-11
- 3. IF YOU REPLACE THE TRANSFER HVPS PCB UNIT OR REGISTRATION-
MARK SENSOR PCB ASSY 1, 2..... 4-14
- 4. IF YOU REPLACE THE LASER UNIT..... 4-15

CHAPTER 5 SERVICE FUNCTIONS 5-1

- 1. MAINTENANCE MODE..... 5-1
 - 1.1 How to Enter the Maintenance Mode..... 5-1
 - 1.2 How to Enter the User-accessible Maintenance Mode..... 5-1
 - 1.3 List of Maintenance-mode Functions 5-2
 - 1.4 Detailed Description of Maintenance-mode Functions 5-3
 - 1.4.1 EEPROM Parameter Initialization (Function code 01, 91) 5-3
 - 1.4.2 Printout of Scanning Compensation Data (Function code 05) 5-4
 - 1.4.3 Placement of Scanner Unit Position for Transportation (Function code 06) 5-7
 - 1.4.4 ADF Performance Test (Function code 08)..... 5-7
 - 1.4.5 Test Pattern (Function code 09) 5-8
 - 1.4.6 Worker Switch (WSW) Setting and Printout 5-9
 - 1.4.7 Operational Check of LCD (Function code 12)..... 5-12
 - 1.4.8 Operational Check of Control Panel PCB (Function code 13) 5-13
 - 1.4.9 ROM Version Check (Function code 25)..... 5-14
 - 1.4.10 Drum Unit Cleaning (Function code 31) 5-15
 - 1.4.11 Operational Check of Sensors (Function code 32)..... 5-16
 - 1.4.12 Switching of the USB Transfer Speed in the PictBridge Mode (Function code 45) 5-20
 - 1.4.13 EEPROM Customizing (User-accessible) (Function code 52)..... 5-21
 - 1.4.14 Received Data Transfer Function (Function code 53)
(MFC-9440CN/ 9450CDN only)..... 5-22
 - 1.4.15 Fine Adjustment of Scan Start/End Positions (Function code 54)..... 5-24
 - 1.4.16 Acquisition of White Level Data Setting (Function code 55)..... 5-25
 - 1.4.17 Adjustment of Color Registration (Function code 66)..... 5-26
 - 1.4.18 Paper Feeding and Ejecting Test (Function code 67) 5-28
 - 1.4.19 Sensitivity Adjustment of Density Sensor (Function code 72) (**Don't use**) 5-28
 - 1.4.20 EEPROM Customizing (Function code 74) 5-29
 - 1.4.21 Sensitivity Adjustment of Registration-mark Sensor (Function code 75) 5-31
 - 1.4.22 Printout of Maintenance Information (Function code 77)..... 5-33
 - 1.4.23 Operational Check of Fans (Function code 78)..... 5-34
 - 1.4.24 Display of the Machine's Log (Function code 80)..... 5-36
 - 1.4.25 Error Code Indication (Function code 82)..... 5-38

1.4.26	Developing Bias Voltage Correction (Function code 83).....	5-38
1.4.27	Output of Transmission Log to the Telephone Line (Function code 87)	5-39
1.4.28	Exit from the Maintenance Mode (Function code 99).....	5-39
2.	OTHER SERVICE FUNCTIONS	5-40
2.1	Resetting the Periodical Replacement Parts Life	5-40
2.1.1	Resetting the Life Counter of the Belt Unit	5-40
2.1.2	Resetting the Life Counter of the Fuser Unit	5-40
2.1.3	Resetting the Life Counter of the Drum Unit.....	5-41
2.1.4	Resetting the Life counter of the Paper Feeding Kit.....	5-41
2.1.5	Resetting the Life Counter of the MP Paper Feeding Kit.....	5-42
2.1.6	Resetting the Life Counter of the Laser Unit.....	5-42
2.2	Develop Roller/ Developing Bias Voltage Counter Reset Function.....	5-43
2.3	Drum Unit Cleaning Mode.....	5-44
2.4	Fuser Motor Speed Adjustment Mode	5-44
CHAPTER 6	CIRCUIT DIAGRAMS, WIRING DIAGRAM.....	6-1
APPENDIX 1	WORKER SWITCH SETTINGS (WSW)	App.1-1
APPENDIX 2	DELETION OF PERSONAL INFORMATION.....	App.2-1
APPENDIX 3	SERIAL NUMBERING SYSTEM	App.3-1
APPENDIX 4	SCREW CATALOGUE	App.4-1
APPENDIX 5	HOW TO MAKE THE DRUM UNIT REMOVE SHEET ...	App.5-1
APPENDIX 6	REFERENCES	App.6-1

REGULATION

<For Europe and Other countries>

■ **Radio interference (220 to 240 volt model only)**

This machine follows EN55022 (CISPR Publication 22)/Class B.

Before you use this product, make sure that you use one of the following interface cables.

(1) A USB cable.

The cable must not be more than 2 meters long.

■ **IEC 60825-1 specification (220 to 240 volt model only)**

This machine is a Class 1 laser product as defined in IEC 60825-1 specifications. The label shown below is attached in countries where it is needed.



This machine has a Class 3B laser diode which produces invisible laser radiation in the laser unit. You should not open the laser unit under any circumstances.

Caution

Use of controls or adjustments or performance of procedures other than those specified in this User's Guide may result in hazardous radiation exposure.

For Finland and Sweden

LUOKAN 1 LASERLAITE

KLASS 1 LASER APPARAT

Varoitus!

Laitteen käyttäminen muulla kuin tässä käyttöohjeessa mainitulla tavalla saattaa altistaa käyttäjän turvallisuusluokan 1 ylittävälle näkymättömälle lasersäteilylle.

Varning

Om apparaten används på annat sätt än i denna Bruksanvisning specificerats, kan användaren utsättas för osynlig laserstrålning, som överskrider gränsen för laserklass 1.

Internal laser radiation

Maximum radiation power:	30 mW
Wave length:	780 - 800 nm
Laser class:	Class 3B

EU Directive 2002/96/EC and EN50419

(European Union only)

This equipment is marked with the recycling symbol (below). It means that at the end of the life of the equipment you must dispose of it separately at an appropriate collection point and not place it in the normal domestic unsorted waste stream. This will benefit the environment for all. (European Union only)



< For USA and Canada >

■ Federal Communications Commission (FCC) Declaration of Conformity
(For USA)

Responsible Party: Brother International Corporation
100 Somerset Corporate Boulevard
P.O. Box 6911
Bridgewater, NJ 08807-0911
USA
Telephone: (908) 704-1700

declares, that the products

Product name: DCP-9040CN, DCP-9042CDN, MFC-9440CN and MFC-9450CDN
Product option: Lower Tray Unit LT-100CL

complies with Part 15 of the FCC Rules. Operation is subject to the following two conditions: (1) This device may not cause harmful interference, and (2) this device must accept any interference received, including interference that may cause undesired operation.

This equipment has been tested and found to comply with the limits for a Class B digital device, pursuant to Part 15 of the FCC Rules. These limits are designed to provide reasonable protection against harmful interference in a residential installation. This equipment generates, uses, and can radiate radio frequency energy and, if not installed and used in accordance with the instructions, may cause harmful interference to radio communications. However, there is no guarantee that interference will not occur in a particular installation. If this equipment does cause harmful interference to radio or television reception, which can be determined by turning the equipment off and on, the user is encouraged to try to correct the interference by one or more of the following measures:

- Reorient or relocate the receiving antenna.
- Increase the separation between the equipment and receiver.
- Connect the equipment into an outlet on a circuit different from that to which the receiver is connected.
- Consult the dealer or an experienced radio/TV technician for help.

Important

A shielded interface cable should be used to ensure compliance with the limits for a Class B digital device. Changes or modifications not expressly approved by Brother Industries, Ltd. could void the user's authority to operate the equipment.

Industry Canada Compliance Statement (For Canada)

This Class B digital apparatus complies with Canadian ICES-003.
Cet appareil numérique de la classe B est conforme à la norme NMB-003 du Canada.

Laser Safety (110 to 120 volt model only)

This machine is certified as a Class 1 laser product under the U.S. Department of Health and Human Services (DHHS) Radiation Performance Standard according to the Radiation Control for Health and Safety Act of 1968. This means that the machine does not produce hazardous laser radiation.

Since radiation emitted inside the machine is completely confined within protective housings and external covers, the laser beam cannot escape from the machine during any phase of user operation.

FDA Regulations (110 to 120 volt model only)

The U.S. Food and Drug Administration (FDA) has implemented regulations for laser products manufactured on and after August 2, 1976. Compliance is mandatory for products marketed in the United States. The following label on the back of the machine indicates compliance with the FDA regulations and must be attached to laser products marketed in the United States.

MANUFACTURED:
Brother Technology (Shenzhen) Ltd.
NO6 Gold Garden Ind., Nanling Buji, Longgang, Shenzhen, China
This product complies with FDA performance standards for laser products except for deviations pursuant to Laser Notice No.50, dated July 26, 2001.

Internal laser radiation

Maximum radiation power:	30 mW
Wave length:	780 - 800 nm
Laser class:	Class 3B

SAFETY INFORMATION

■ **Caution for Laser Product (WARNHINWEIS für Laser drucker)**

- CAUTION: When the machine during servicing is operated with the cover open, the regulations of VBG 93 and the performance instructions for VBG 93 are valid.
- CAUTION: In case of any trouble with the laser unit, replace the laser unit itself. To prevent direct exposure to the laser beam, do not try to open the enclosure of the laser unit.
- ACHTUNG: Im Falle von Störungen der Lasereinheit muß diese ersetzt werden. Das Gehäuse der Lasereinheit darf nicht geöffnet werden, da sonst Laserstrahlen austreten können.

■ **Additional Information**



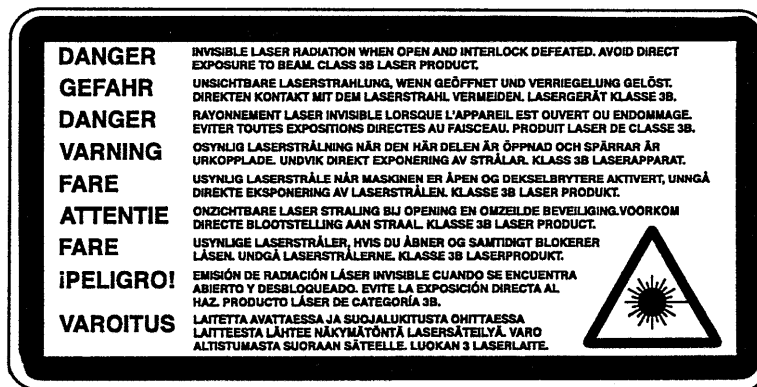

When servicing the optical system of the machine, be careful not to place a screwdriver or other reflective object in the path of the laser beam. Be sure to take off any personal accessories such as watches and rings before working on the machine. A reflected beam, though invisible, can permanently damage the eyes.

Since the beam is invisible, the following caution label is attached on the laser unit.



■ Definitions of Warnings, Cautions, Notes and Memos

The following conventions are used in this manual:

Mark	Contents
	Warnings tell you what to do to prevent possible personal injury.
	Electrical Hazard icons alert you to a possible electrical shock.
	Hot Surface icons warn you not to touch machine parts that are hot.
	Cautions specify procedures you must follow or avoid to prevent possible damage to the machine or other objects.
Note	Notes tell you useful tips when servicing the machine.
Memo	Memo tells you bits of knowledge to help understand the machine.

■ **Safety Precautions**

Listed below are the various kinds of “WARNING” messages included in this manual.

WARNING



There are high voltage electrodes inside the machine. Before you clean the inside of the machine or replace parts, make sure that you have turned off the power switch and unplugged the machine from the AC power outlet.

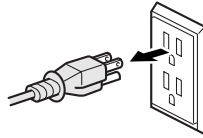

DO NOT handle the plug with wet hands. Doing this might cause an electrical shock.

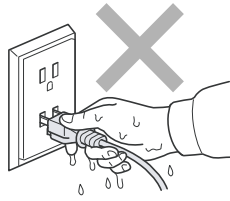

The fuser unit becomes extremely hot during operation. Wait until it has cooled down sufficiently before replacing consumable items. DO NOT remove or damage the caution label located on or around the fuser.

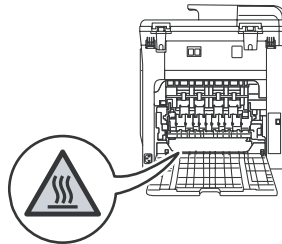

! WARNING

DO NOT use a vacuum cleaner to clean up scattered toner. Doing this might cause the toner dust to ignite inside the vacuum cleaner, potentially starting a fire. Carefully clean the toner dust with a dry, lint-free cloth and dispose of it according to local regulations.

DO NOT use any type of spray to clean inside or outside of the machine. Doing this may cause a fire or electrical shock.



If the machine becomes hot, blows smoke, or generates obscure odor, immediately turn off the power switch and unplug the machine from the AC power outlet.

If metal objects, water or other liquids get inside the machine, immediately turn off the power switch and unplug the machine from the AC power outlet.

To prevent injuries, be careful not to put your hands on the edge of the machine under the document cover.

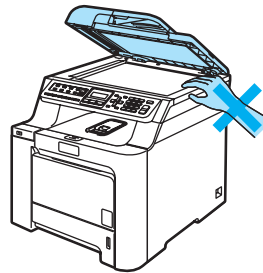

To prevent injuries, be careful not to put your fingers in the area shown in the illustrations.

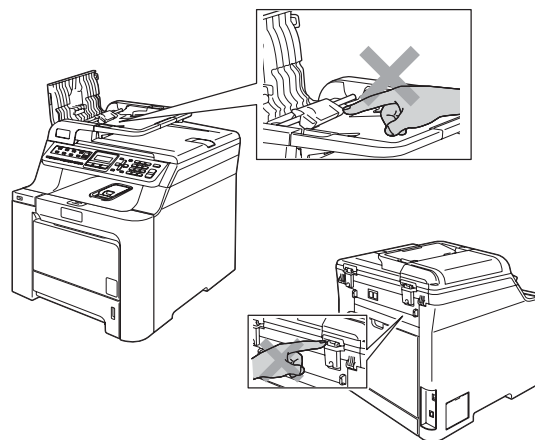

! WARNING

When you move the machine, grasp the side hand holds that are located at the bottom of the machine. DO NOT carry the machine by holding scanner unit. To prevent injuries when moving or lifting this machine, make sure to use at least two people.

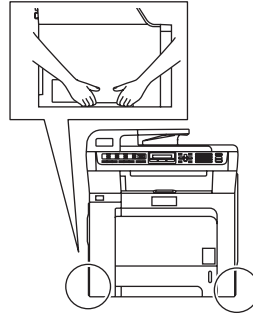

Use caution when installing or modifying telephone lines. Never touch telephone wires or terminals that are not insulated unless the telephone line has been unplugged at the wall jack. Never install telephone wiring during a lightning storm. Never install a telephone wall jack in a wet location.

This product must be installed near an AC power outlet that is easily accessible. In case of an emergency, you must disconnect the power cord from the AC power outlet to shut off the power completely.

IMPORTANT SAFETY INSTRUCTIONS

When using your telephone equipment, basic safety precautions should always be followed to reduce the risk of fire, electric shock and injury to people, including the following:

1. Do not use this product near water, for example, near a bath tub, wash bowl, kitchen sink, washing machine, or in a wet basement or near a swimming pool.
2. Avoid using this product during an electrical storm. There may be a remote risk of electric shock from lightning.
3. Do not use this product to report a gas leak in the vicinity of the leak.
4. Use only the power cord provided with the machine.
5. Do not dispose of batteries in a fire. They may explode. Check with local codes for possible special disposal instructions.

SAVE THESE INSTRUCTIONS

Caution

Lightning and power surges can damage this product! We recommend that you use a quality surge protection device on the AC power line, or unplug the machine during a lightning storm.

■ About Copying

CAUTION

LEGAL LIMITATIONS

Color reproductions of certain documents are illegal and may result in either criminal or civil liability. This memorandum is intended to be a guide rather than a complete listing of every possible prohibition. In case of doubt, we suggest that you check with counsel as to any particular questionable documents.

The following documents issued by the United States/Canadian Government or any of its Agencies may not be copied:

- Money
- Bonds or other certificates of indebtedness
- Certificates of Deposit
- Internal Revenue Stamps (canceled or uncanceled)
- Selective Service or draft papers
- Passports
- United States/Canadian Postage Stamps (canceled or uncanceled)
- Food Stamps
- Immigration Papers
- Checks or drafts drawn by Governmental agencies
- Identifying badges or insignias

Copyrighted works cannot be copied. Sections of a copyrighted work can be copied for 'fair use.' Multiple copies would indicate improper use.

Works of art should be considered the equivalent of copyrighted works.

Licenses and Certificates of Title to motor vehicles may not be copied under certain state/provincial laws.

CHAPTER 1 TROUBLESHOOTING

1. INTRODUCTION

Troubleshooting is the counter measure procedures that the service personnel should follow if an error or malfunction occurs with the machine. It is impossible to anticipate all of the possible troubles which may occur in future and determine the troubleshooting procedures, so this chapter covers some sample troubles. However, those samples will help the service personnel pinpoint and repair other defective elements.

1.1 Precautions

Be sure to observe and follow all the precautions to prevent any secondary problems from happening during troubleshooting.

- (1) Always turn off the power and unplug the power cable before removing any covers or PCBs, adjusting the machine and so on. If you need to take voltage measurements with the power switched on, take the greatest of care not to receive an electric shock.
- (2) When connecting or disconnecting cable connectors, make sure that you hold the connector body and not the cables.
- (3) Electronic devices are sensitive to static build up; make sure that you touch a metal portion of the machine to discharge yourself before accessing the PCBs. Handle PCBs with care when repairing them.

Verify again that the repaired portion works properly.

1.2 Initial Check

Check the following items before attempting to repair the machine.

<Operating Environment>

- (1) Put your machine on a flat, stable surface such as a desk that is free of vibration and shocks.
- (2) Use the machine in a well-ventilated room; use the machine within the following ranges of temperature and humidity: temperature between 10°C and 32.5°C (50 °F to 90.5 °F), and the relative humidity is maintained between 20% and 80%.
- (3) Ensure the machine is not exposed to direct sunlight, excessive heat, moisture, or dust.
- (4) Keep the machine horizontal when you carry it. To prevent injuries when moving or lifting this machine, make sure to use at least two people.

<Power Supply>

- (1) The AC input power supply described on the rating plate of the machine should be within $\pm 10\%$ of the rated voltage.
- (2) The AC input power supply is within the regulated value.
- (3) The cables and harnesses are connected correctly.
- (4) The fuses are not blown.

<Paper>

- (1) A recommended type of paper is being used. (Refer to "2.6 Paper" in Reference 1.)
- (2) The paper is not damp.
- (3) The paper is not short-grained paper or acid paper.

<Consumable Parts>

- (1) The drum unit (including the toner cartridge) is installed correctly.
- (2) The belt unit and waste toner box are installed correctly.

<Others>

- (1) Condensation

When the machine is moved from a cold place into a warm room, condensation may occur inside the machine, causing various problems as listed below.

- Condensation on the optical surfaces such as the scanner window, lenses, the reflection mirror and the protection glass may cause the print image to be light.
- If the exposure drum is cold, the electrical resistance of the photosensitive layer is increased, making it impossible to obtain the correct contrast when printing.
- Condensation on the charge unit may cause corona charge leakage.
- Condensation on the plate and separation pad may cause paper feed problems.

If condensation has occurred, leave the machine for at least 2 hours to allow it to reach room temperature.

If the drum unit is unpacked soon after it is moved from a cold place to a warm room, condensation may occur inside the unit which may cause incorrect images. Instruct the user to allow the unit to come to room temperature before unpacking it. This will take one or two hours.

- (2) Low temperature

If the room temperature is low the motor may not drive normally, this is due to there being too much load to drive the drum unit. In this case, the "**Low Temperature/ Increase room temperature to allow the machine to operate**" message will appear on the LCD. Increase the room temperature when the above message is indicated.

- (3) Cleaning

Use a soft dry cloth.

CAUTION:

DO NOT use any type of spray to clean inside or outside of the machine. Doing this may cause a fire or electrical shock.



2. ERROR CODES

This machine includes a self-diagnosis function. If the machine does not work normally it judges that an error has occurred, and indicates the corresponding error message on the LCD, which in turn helps the end user to quickly find out the problem.

2.1 Error Indication

The error codes **shaded** in the table below are recoverable errors if following the User Check items.

Error codes	Problem	Refer to:	Error codes	Problem	Refer to:
20	Laser diode failure (K)	1-8	55	Replace the laser unit	1-6
21	Laser diode failure (Y)	1-8	56	Back cover opened	1-15
22	Laser diode failure (M)	1-8	57	Paper jam while turning it over in duplex printing or DX solenoid failure	1-16
23	Laser diode failure (C)	1-8	58	Fuser unit failure	1-16
24	Internal temperature sensor failure	1-8	59	Fuser unit failure	1-16
25	Develop drive motor failure	1-9	5A	Charge HVPS PCB ASSY failure	1-17
26	Belt drive motor failure	1-9	5E	Replace the belt unit	1-6
27	Paper feed/belt cleaner motor failure	1-9	5F	Replace the waste toner box	1-17
28	Drum drive motor 1 (K, Y) failure	1-9	60	Toner cartridge (C) is at the end of life.	1-17
29	Drum drive motor 2 (M, C) failure	1-9	61	Toner cartridge (M) is at the end of life.	1-17
2A	Belt cleaner release sensor failure	1-10	62	Toner cartridge (Y) is at the end of life.	1-17
2B	Air intake fan (AIR) failure	1-10	63	Toner cartridge (K) is at the end of life.	1-17
2C	Toner sensor PCB failure (K)	1-11	68	Fuser unit failure	1-18
2D	Toner sensor PCB failure (Y)	1-11	69	Fuser unit failure	1-18
2E	Toner sensor PCB failure (M)	1-11	6A	Fuser unit failure	1-18
2F	Toner sensor PCB failure (C)	1-11	6B	Fuser unit failure	1-18
30	Incorrect EL lamp current value	1-11	6C	Fuser unit failure	1-18
31	Density sensor failure	1-12	6D	Fuser unit failure	1-18
32	Density sensor shutter performance malfunction	1-12	6E	Fuser unit failure	1-18
33	Color registration sensor failure	1-12	6F	Fuser unit failure	1-18
34	Color adjustment shutter failure	1-13	71	Polygon motor failure	1-19
35	NVRAM failure on Engine PCB	1-13	72	Beam detecting sensor (K) failure	1-19
36	Transfer HVPS PCB failure	1-13	73	Beam detecting sensor (C) failure	1-19
37	Belt unit temperature sensor failure	1-13	74	Toner cartridge whose color is used reaches the end of life during printing.	1-20
38	THM sensor failure	1-14	75	Machine cooling down inside	1-6
39	HUM sensor failure	1-14	76	Fuser unit failure	1-20
3A	Engine communication error	1-14	78	Fuser unit failure	1-20
3B	Main PCB RAM failure	1-15	7C	Engine communication error	1-14
3D	Main PCB failure	1-15	7D	Dirt on drum unit	1-21
3F	Writing error into engine firmware	1-15	82	Density patch measurement is not completed normally when implementing calibration from the control panel.	1-21
50	Replace the drum unit	1-5	84	Paper jam rear side of the machine	1-22
51	Replace the MP paper feeding kit	1-5			
52	Replace the T1 paper feeding kit	1-5			
53	Replace the LT paper feeding kit	1-5			
54	Replace the fuser unit	1-6			

Error codes	Problem	Refer to:	Error codes	Problem	Refer to:
85	Tray 1 (T1) is not installed into the machine.	1-23	B3	Detection error of the scanning area on the left end	1-29
86	Tray 2 (T2) is not installed into the machine.	1-23	B4	Detection error of the scanning area on the right end	1-29
87	Toner cartridge whose color is used reaches the end of life when implementing calibration from the control panel.	1-20	B5	Detection error of horizontal scanning edge reduction in scanning area setting	1-29
88	Paper jam inside the machine	1-22	B6	Detection error of horizontal scanning edge magnification in scanning area setting	1-29
89	Incorrect paper size in duplex printing	1-23	B9	Scanning light adjustment error is detected.	1-30
8A	Paper jam in Tray 1 (T1)	1-24			
8B	Paper jam in Tray 2 (LT)	1-24	BB	White level data error	1-30
8C	Paper jam in MP tray (MP)	1-24	BD	Black level data error	1-30
8E	Auto color registration failure when implementing it from the control panel	1-25	BE	Detection error of scanning starting edge	1-30
8F	Sensor sensitivity adjustment failure when implementing auto color registration from the control panel	1-25	BF	Duplex scanning cannot be implemented due to too long document.	1-31
99	Specified paper size is not supported for duplex printing (DX).	1-7	C0	Identification failure for a new toner cartridge (K)	1-31
9B	Request on developing bias voltage adjustment	1-7	C1	Identification failure for a new toner cartridge (Y)	1-31
9C	Request on auto color registration	1-7	C2	Identification failure for a new toner cartridge (M)	1-31
9D	Incorrect sensor measurement value when implementing auto color registration from the control panel	1-25	C3	Identification failure for a new toner cartridge (C)	1-31
9E	Toner cartridge whose color is used reaches the end of life when implementing auto color registration from the control panel.	1-20	C4	Tray 2 (LT) plate-up function malfunction	1-32
			C5	EL lamp electrifying failure	1-32
			C6	Toner cartridge mis-dividing	1-32
			C7	Insufficient DIMM memory	1-7
			C8	RAM area for secure data full	1-33
			C9	Defective DIMM is installed.	1-7
A1	Front cover opened	1-26	CA	Excess current to USB device	1-33
A2	Document is too long.	1-26	CB	Belt unit is not installed into the machine.	1-33
A3	Document rear sensor is not turned on when feeding the document.	1-26	CC	Fuser unit is not installed into the machine.	1-34
A5	Fax scanning error (The first warning only)	1-27	CD	Drum unit is not installed into the machine.	1-34
A6	Fax scanning error (The second warning that the same error with A5 occurs again)	1-27	CE	Waste toner box is not installed into the machine.	1-36
A7	Color parameter failure	1-27	CF	Waste toner box full	1-36
AD	DMA transfer error	1-27	D0-DF	Modem error	1-36
AE	FB unit home position sensor is not turned on.	1-28	E0	Program error. (An error occurred in the ROM checksum.)	1-37
AF	FB unit home position sensor is not turned off.	1-28	E1	Program error.	1-37
B0	Harness for scanning is not connected correctly.	1-28	E6	NVRAM error on main PCB	1-37
			EB	NVRAM reading error on laser unit	1-37
			EF	Incorrect print coverage value	1-38
			F8	Battery connection failure	1-38

2.2 Error Cause and Remedy

2.2.1 Recoverable Error by User Check

These errors are recoverable by following the message indicated on the LCD or following the items indicated in User Check.

■ **Error code 50**

Drum End Soon

Replace the drum unit

User Check

- Replace the drum unit with a new one.
- After replacing the drum unit, reset the counter using the control panel on the machine.
(Refer to “2.3 Parts Life Reset Function” in Chapter 2.)

■ **Error code 51**

Change PF Kit MP

Replace the MP paper feeding kit

User Check

- Replace the MP paper feeding kit with a new one.
- After replacing the MP paper feeding kit, reset the counter using the control panel on the machine.
(Refer to “2.3 Parts Life Reset Function” in Chapter 2.)

■ **Error code 52**

Change PF Kit 1

Replace the T1 paper feeding kit

User Check

- Replace the T1 paper feeding kit with a new one.
- After replacing the T1 paper feeding kit, reset the counter using the control panel on the machine.
(Refer to “2.3 Parts Life Reset Function” in Chapter 2.)

■ **Error code 53 (MFC-9440CN/ 9450CDN only)**

Change PF Kit 2

Replace the LT paper feeding kit

User Check

- Replace the LT paper feeding kit with a new one.
- After replacing the LT paper feeding kit, reset the counter using the control panel on the machine.
(Refer to “2.3 Parts Life Reset Function” in Chapter 2.)

■ **Error code 54**

Fuser Unit End

Replace the fuser unit

User Check

- Replace the fuser unit with a new one.
- After replacing the fuser unit, reset the counter using the control panel on the machine.
(Refer to “2.3 Parts Life Reset Function” in Chapter 2.)

■ **Error code 55**

Laser Unit End

Replace the laser unit

User Check

- Replace the laser unit with a new one.
- After replacing the laser unit, reset the counter using the control panel on the machine.
(Refer to “2.3 Parts Life Reset Function” in Chapter 2.)

■ **Error code 5E**

Change Belt Unit

Replace the belt unit

User Check

- Replace the belt unit with a new one.
- After replacing the belt unit, reset the counter using the control panel on the machine.
(Refer to “2.3 Parts Life Reset Function” in Chapter 2.)

■ **Error code 75**

Cooling Down

The machine is cooling down inside for protection.

The machine indicates “Cooling Down” in one of the conditions below.

- (1) The temperature inside the machine is too high.
- (2) Both ends of the heat roller are at different temperatures.
- (3) The paper media is replaced.

■ **Error code 99** (DCP-9042CDN/ MFC-9450CDN only)

Size Error DX

Press Cancel. Specify the correct paper and load the same size paper as the Printer driver setting.

Specified paper size is not supported for duplex printing (DX).

User Check

- Check if the selected paper is supported for duplex printing.
- Check the size setting of the tray to feed paper.

■ **Error code 9B** (* This error can be found out only in "Maintenance mode 82".)

Print Unable 9B

Request on developing bias voltage adjustment

User Check

- The machine starts implementing the developing bias voltage adjustment automatically when it enters the standby status.

■ **Error code 9C** (* This error can be found out only in "Maintenance mode 82".)

Print Unable 9C

Request on auto color registration

User Check

- The machine starts implementing color registration automatically when it enters the standby status.

■ **Error code C7**

Out of Memory

Add more Memory.

Insufficient DIMM memory

User Check

- Install additional DIMM memory.

■ **Error code C9**

DIMM Error

Make sure that the DIMM is inserted correctly.

Defective DIMM is installed.

User Check

- Check if the DIMM is installed correctly.
- Replace the DIMM with a new one.

2.2.2 Service Call Error

Check the User Check items first. If the same problem occurs follow each procedure in the order of the number described in the Step column in the table below.

■ **Error code 20(K)**

Print Unable 20
Turn the power off and then back on again.

Laser diode failure (K)

Error code 21(Y)

Print Unable 21
Turn the power off and then back on again.

Laser diode failure (Y)

Error code 22(M)

Print Unable 22
Turn the power off and then back on again.

Laser diode failure (M)

Error code 23(C)

Print Unable 23
Turn the power off and then back on again.

Laser diode failure (C)

Step	Cause	Remedy
1	Laser unit harness connection failure	Check the two harness connections of the laser unit and reconnect them.
2	Laser unit failure	Replace the laser unit.
3	Engine PCB failure	Replace the engine PCB ASSY.

■ **Error code 24**

Print Unable 24
Turn the power off and then back on again.

Internal temperature sensor failure

Step	Cause	Remedy
1	Harness connection failure of internal temperature sensor	Check the harness connection of the internal temperature sensor and reconnect it.
2	Engine PCB failure	Replace the engine PCB ASSY.

■ **Error code 25**

Print Unable 25
Turn the power off and then back on again.

Develop drive motor failure

Error code 26

Print Unable 26
Turn the power off and then back on again.

Belt drive motor failure

Error code 27

Print Unable 27
Turn the power off and then back on again.

Paper feed/belt cleaner motor failure

Step	Cause	Remedy
1	Motor harness connection failure	Check the harness connection of the appropriate motor and reconnect it.
2	Motor failure	Replace the appropriate motor.
3	Engine PCB failure	Replace the engine PCB ASSY.
4	Low-voltage power supply PCB failure	Replace the PS PCB unit.

■ **Error code 28**

Print Unable 28
Turn the power off and then back on again.

Drum drive motor 1 (K, Y) failure

Error code 29

Print Unable 29
Turn the power off and then back on again.

Drum drive motor 2 (M, C) failure

Step	Cause	Remedy
1	Drum drive motor harness connection failure	Check the harness connection of the drum drive motor and reconnect it.
2	Drum phase sensor PCB failure	Replace the drum phase sensor PCB ASSY.
3	Drum drive motor failure	Replace the drum drive motor.
4	Engine PCB failure	Replace the engine PCB ASSY.

■ Error code 2A

Print Unable 2A

Turn the power off and then back on again.

Belt cleaner release sensor failure

Step	Cause	Remedy
1	Rotation defective of release shaft A of waste toner box.	Replace the waste toner box.
2	Harness connection failure between belt cleaner release sensor PCB and belt cleaner release solenoid.	Check the harness connection between the belt cleaner release sensor PCB and belt cleaner release solenoid and reconnect them.
3	Belt cleaner release sensor actuator performance defective	Replace the belt cleaner release ASSY.
4	Belt cleaner release sensor PCB failure	Check the sensor performance following the procedure described in "Maintenance mode 32". If any problem occurs, replace the belt cleaner release sensor PCB ASSY.
5	Belt cleaner release solenoid failure	Replace the belt cleaner release ASSY.
6	Engine PCB failure	Replace the engine PCB ASSY.

■ Error code 2B

Print Unable 2B

Turn the power off and then back on again.

Air intake fan (AIR) failure, or short-circuit of fuser unit fan (FU), LVPS fan (PS), or drum unit fan (OPC)

Step	Cause	Remedy
1	Air intake fan (AIR) harness connection failure	Check the harness connection of the air intake fan (AIR) and reconnect it.
2	Short-circuit of air intake fan (AIR), fuser unit fan (FU), LVPS fan (PS), or drum unit fan (OPC)	Check if the harness terminal of any of these fans is short-circuited using the tester. If any of the fans is short-circuited, replace the short-circuited fan and the engine PCB ASSY at the same time. The harness terminals that must be checked are: - Air intake fan (AIR): Between 1 and 3 pins - Fuser unit fan (FU): Between 1 and 2 pins - LVPS fan (PS): Between 1 and 2 pins - Drum unit fan (OPC): Between 1 and 2 pins
3	Air intake fan (AIR) failure	If no fans are short-circuited in Step 2, replace the air intake fan (AIR).
4	Engine PCB failure	If no fans are short-circuited in Step 2, replace the engine PCB ASSY.

■ **Error code 2C(K)**

Print Unable 2C
Turn the power off and then back on again.

Error code 2D(Y)

Print Unable 2D
Turn the power off and then back on again.

Error code 2E(M)

Print Unable 2E
Turn the power off and then back on again.

Error code 2F(C)

Print Unable 2F
Turn the power off and then back on again.

Toner sensor PCB failure for the appropriate color

Step	Cause	Remedy
1	Toner sensor PCB (TE/NEW) failure	Check the sensor performance following the procedure described in "Maintenance mode 32". If any problem occurs, replace the toner sensor PCB ASSY (TE/NEW) for the appropriate color.
2	Engine PCB failure	Replace the engine PCB ASSY.

■ **Error code 30**

Print Unable 30
Turn the power off and then back on again.

Incorrect EL lamp current value

User Check

- Replace the drum unit with a new one.

Step	Cause	Remedy
1	Drum unit electrode dirty	Clean the electrodes of the main body and the drum unit. (Refer to Fig.1-1 (P1-35).)

■ **Error code 31**

Print Unable 31
Turn the power off and then back on again.

Density sensor failure

Error code 32

Print Unable 32
Turn the power off and then back on again.

Density sensor shutter performance malfunction

User Check

- Check if there is a scratch, dirt or the like on the belt unit. If there is, replace the belt unit with a new one.

Step	Cause	Remedy
1	Harness connection failure of density sensor holder ASSY	Check the harness connection between the density sensor holder ASSY and registration relay PCB, and the one between the registration relay PCB and engine PCB. Then, reconnect them.
2	Harness connection failure of density sensor solenoid ASSY	Check the harness connection between the engine PCB and registration relay PCB and reconnect them.
3	Density sensor holder ASSY failure	Replace the density sensor holder ASSY.
4	Transfer HVPS PCB unit failure	Replace the transfer HVPS PCB unit.
5	Engine PCB failure	Replace the engine PCB ASSY.

■ **Error code 33**

Print Unable 33
Turn the power off and then back on again.

Color registration sensor failure

User Check

- Check if there is a scratch, dirt or the like on the belt unit. If there is, replace the belt unit with a new one.

Step	Cause	Remedy
1	Harness connection failure of registration-mark sensor PCB ASSY	Check the harness connection of the registration-mark sensor PCB ASSY and reconnect it.
2	Registration-mark sensor PCB failure	Check the performance of the registration-mark sensor following the procedure described in "Maintenance mode 75". If any problem occurs, replace the registration-mark sensor PCB ASSY.
3	Transfer HVPS PCB unit failure	Replace the transfer HVPS PCB unit.
4	Engine PCB failure	Replace the engine PCB ASSY.

■ **Error code 34**

Print Unable 34

Color adjustment shutter failure

Step	Cause	Remedy
1	Density sensor shutter catching on some position	Correct catching of the density sensor shutter.
2	Density sensor holder ASSY assembling failure	Reassemble the density sensor holder ASSY correctly.

■ **Error code 35**

Print Unable 35

Turn the power off and then back on again.

NVRAM failure on Engine PCB

Step	Cause	Remedy
1	Engine PCB failure	Replace the engine PCB ASSY.

■ **Error code 36**

Print Unable 36

Turn the power off and then back on again.

Transfer HVPS PCB failure

Step	Cause	Remedy
1	Harness connection failure of transfer HVPS PCB ASSY	Check the two harness connections between the transfer HVPS PCB and registration relay PCB, and the two ones between the registration relay PCB and engine PCB. Then reconnect them.
2	Transfer HVPS PCB ASSY failure	Replace the transfer HVPS PCB ASSY.
3	Engine PCB failure	Replace the engine PCB ASSY.

■ **Error code 37**

Print Unable 37

Turn the power off and then back on again.

Belt unit temperature sensor failure

Step	Cause	Remedy
1	Belt unit temperature sensor harness connection failure	Check the harness connection between the belt unit temperature sensor and registration relay PCB, and the one between the registration relay PCB and engine PCB. Then reconnect them.
2	Transfer HVPS PCB unit failure	Replace the transfer HVPS PCB unit.
3	Engine PCB failure	Replace the engine PCB ASSY.

Error code 38

Print Unable 38
Turn the power off and then back on again.

THM (Thermistor) sensor failure

Error code 39

Print Unable 39
Turn the power off and then back on again.

HUM (Humidity) sensor failure

Step	Cause	Remedy
1	Harness connection failure of THM/HUM sensor	Check the harness connection of the THM/HUM sensor and reconnect it.
2	THM/HUM sensor failure	Replace the THM/HUM sensor holder ASSY.
3	Engine PCB failure	Replace the engine PCB ASSY.

■ Error code 3A

Print Unable 3A
Turn the power off and then back on again.

Error code 7C

Print Unable 7C
Turn the power off and then back on again.

Engine communication error

Step	Cause	Remedy
1	Harness connection failure between engine PCB and main PCB	Check the harness connection between the engine PCB and main PCB, and reconnect it.
2	Engine PCB failure	Replace the engine PCB ASSY.
3	Main PCB failure	Replace the main PCB ASSY.

■ **Error code 3B**

Print Unable 3B
Turn the power off and then back on again.

Main PCB RAM failure

Step	Cause	Remedy
1	Main PCB failure	Replace the main PCB ASSY.

■ **Error code 3D**

Print Unable 3D
Turn the power off and then back on again.

Main PCB failure (Any of the PCBs is judged to be failure by the PCB checker, or it is not tested with the checker.)

Step	Cause	Remedy
1	Main PCB failure	Replace the main PCB ASSY.
2	Engine PCB failure	Replace the engine PCB ASSY.

■ **Error code 3F**

Print Unable 3F
Turn the power off and then back on again.

Writing error into engine firmware

Step	Cause	Remedy
1	The machine is turned off while rewriting the data into the engine firmware.	Turn the power on. Resend the engine firmware (DJF format) with the USB memory while the error code is being indicated.

■ **Error code 56**

Cover is Open
Close the Back Cover.

Back cover opened

User Check

- Check if the back cover is closed correctly.

Step	Cause	Remedy
1	Back cover switch failure	Check the sensor performance following the procedure described in "Maintenance mode 32".
2	Harness connection failure of back cover switch ASSY	Check the harness connection of the back cover switch ASSY and reconnect it.
3	The boss pressing back cover switch is broken.	Replace the back cover ASSY.
4	Engine PCB failure	Replace the engine PCB ASSY.

■ **Error code 57 (DCP-9042CDN/ MFC-9450CDN)**

Jam Duplex

Pull out Tray 1 completely. Check inside the machine or open the Back Cover to remove the jammed paper.

Paper jam while turning it over in duplex printing, or DX (Duplex) solenoid failure

User Check

- Check if the paper is jammed or not. If jammed, remove it.

Step	Cause	Remedy
1	DX feed ASSY not assembled correctly	Reassemble the DX feed ASSY.
2	Paper eject ASSY harness connection failure	Check the harness connection of the paper eject ASSY and reconnect it.
3	DX solenoid failure	Replace the paper eject ASSY.
4	Engine PCB failure	Replace the engine PCB ASSY.

■ **Error code 58**

Fuser Error

Turn the power off, then on again. Leave the machine for 15 min.

Error code 59

Self-Diagnostic

Will Automatically Restart within 15 minutes.

If the same error is detected again 15 minutes later, the message below is indicated.

Print Unable 6A

Turn the power off and then back on again.

Fuser unit failure * The code included in the message above is one of 68, 69, 6A, 6B, 6C, 6D, 6E, 6F, 76 and 78.

Step	Cause	Remedy
1	Harness connection failure between fuser unit connector and engine PCB	Check the harness connection between the fuser unit connector and engine PCB, and reconnect it.
2	Fuser unit failure	Replace the fuser unit.
3	Low-voltage power supply PCB failure	Replace the PS PCB unit.
4	Engine PCB failure	Replace the engine PCB ASSY.

■ Error code 5A

Print Unable 5A
Turn the power off and then back on again.

Charge HVPS PCB failure

Step	Cause	Remedy
1	Charge HVPS PCB ASSY harness connection failure	Check the harness connection between the charge HVPS PCB and engine PCB, and the one between the charge HVPS PCB and low-voltage power supply PCB. Then, reconnect them.
2	Charge HVPS PCB failure	Replace the charge HVPS PCB ASSY.
3	Engine PCB failure	Replace the engine PCB ASSY.

■ Error code 5F

Waste Toner Soon

Replace the waste toner box

User Check

- Replace the waste toner box with a new one.

Step	Cause	Remedy
1	Waste toner sensor failure	Check the sensor performance following the procedure described in "Maintenance mode 32". If any problem occurs, replace the waste toner near/full sensor ASSY.
2	Harness connection failure of waste toner near/full sensor ASSY	Check the harness connection of the waste toner near/full sensor ASSY and reconnect it.
3	Engine PCB failure	Replace the engine PCB ASSY.

■ Error code 60(C), 61(M), 62(Y), 63(K)

Toner Life End
Replace <color> Toner Cartridge.

Toner cartridge is at the end of life.

User Check

- Gently shake the toner cartridge of the appropriate color from side to side and install it again.
- Replace the toner cartridge of the appropriate color.

Step	Cause	Remedy
1	Harness connection failure of toner sensor PCB ASSY (TE/NEW)	Check the sensor performance following the procedure described in "Maintenance mode 32". If any problem occurs, check the harness connection of the toner sensor PCB ASSY (TE/NEW) of the appropriate color, then reconnect it.
2	Toner sensor PCB (TE/NEW) failure (Toner empty)	Replace the toner sensor PCB ASSY (TE/NEW) of the appropriate color.
3	Engine PCB failure	Replace the engine PCB ASSY.

■ **Error code 68**

Print Unable 68
Turn the power off and then back on again.

Fuser unit failure (The side thermistor detects higher temperature than the specified value.)

Error code 69

Print Unable 69
Turn the power off and then back on again.

Fuser unit failure (The side thermistor detects lower temperature than the specified value.)

Error code 6A

Print Unable 6A
Turn the power off and then back on again.

Fuser unit failure (The side thermistor does not detect 60°C within the specified time.)

Error code 6B

Print Unable 6B
Turn the power off and then back on again.

Fuser unit failure (The center thermistor does not detect 100°C within the specified time.)

Error code 6C

Print Unable 6C
Turn the power off and then back on again.

Fuser unit failure (The center thermistor detects higher temperature than the specified value.)

Error code 6D

Print Unable 6D
Turn the power off and then back on again.

Fuser unit failure (The center thermistor detects lower temperature than the specified value.)

Error code 6E

Print Unable 6E
Turn the power off and then back on again.

Fuser unit failure (The center thermistor does not detect temperature rising within the specified time.)

Error code 6F

Print Unable 6F
Turn the power off and then back on again.

Fuser unit failure (The center and side thermistors detect extremely high temperature.)

Step	Cause	Remedy
1	Fuser unit failure	Replace the fuser unit.
2	Low-voltage power supply PCB failure	Replace the PS PCB unit.
3	Engine PCB failure	Replace the engine PCB ASSY.

■ **Error code 71**

Print Unable 71
Turn the power off and then back on again.

Polygon motor failure

Error code 72

Print Unable 72
Turn the power off and then back on again.

Beam detecting sensor (K) failure

Error code 73

Print Unable 73
Turn the power off and then back on again.

Beam detecting sensor (C) failure

Step	Cause	Remedy
1	Condensation on laser unit	Turn the power off and leave the machine in an airy place at normal room temperature.
2	Laser unit harness connection failure	Check the two harness connections of the laser unit and reconnect them.
3	Laser unit failure	Replace the laser unit.
4	Engine PCB failure	Replace the engine PCB ASSY.

■ **Error code 74** (* This error can be found out only in "Maintenance mode 82".)

Print Unable 74

Toner cartridge whose color is used reaches the end of life during printing.

Error code 87

Calibrate

Calibration failed. Insufficient Toner for Calibration.

Toner cartridge whose color is used reaches the end of life when implementing calibration from the control panel.

Error code 9E

Registration

Registration failed. Insufficient Toner for Registration.

Toner cartridge whose color is used reaches the end of life when implementing auto color registration from the control panel.

User Check

- If any of the toner cartridges reaches the end of life, replace it with a new one.

Step	Cause	Remedy
1	Toner sensor PCB (TE/NEW) failure (Toner empty)	Check the sensor performance following the procedure described in "Maintenance mode 32". If any problem occurs, replace the toner sensor PCB (TE/NEW) of the appropriate color.
2	Engine PCB failure	Replace the engine PCB ASSY.

■ **Error code 76**

Print Unable 76

Turn the power off and then back on again.

Fuser unit failure (The center thermistor detects rapid temperature rising.)

Step	Cause	Remedy
1	Fuser unit failure	Replace the fuser unit.

■ **Error code 78**

Print Unable 78

Turn the power off and then back on again.

Fuser unit failure (The center thermistor detects rapid temperature falling.)

Step	Cause	Remedy
1	Harness connection failure between fuser unit connector and engine PCB	Check the harness connection between the fuser unit connector and engine PCB, and reconnect it.
2	Fuser unit failure	Replace the fuser unit.

■ Error code 7D

Drum Error

Slide the Green tab on Drum Unit in each color. Refer to the User's Guide for the procedures.

Dirt on drum unit

User Check

- Clean the corona wire in the drum unit.
- Replace the drum unit with a new one.

Step	Cause	Remedy
1	Dirt or dust on drum unit electrodes	Clean the electrodes of the main body and the drum unit. (Refer to Fig. 1-1 (P1-35).)
2	Charge HVPS PCB failure	Replace the charge HVPS PCB ASSY.
3	Engine PCB failure	Replace the engine PCB ASSY.

■ Error code 82

Calibrate

Calibration failed. Press start, and try again.

Density patch measurement is not completed normally when implementing calibration from the control panel.

User Check

- Check if there is a scratch, dirt or the like on the belt unit. If there is, replace the belt unit with a new one.
- Check if the genuine toner cartridges are installed in the correct order of colors.

Step	Cause	Remedy
1	Density sensor shutter not operating smoothly or catching in some position	Correct smooth operation of the density sensor shutter.
2	Harness connection failure of density sensor holder ASSY	Check the harness connection of the density sensor holder ASSY and reconnect it.
3	Density sensor failure	Replace the density sensor holder ASSY.
4	Transfer HVPS PCB failure	Replace the transfer HVPS PCB ASSY.
5	Engine PCB failure	Replace the engine PCB ASSY.

■ Error code 84 (Jam Rear)

Jam Rear

Open the Back Cover and remove the jammed paper.

Paper jam rear side of the machine

Error code 88 (Jam Inside)

Jam Inside

Open the Front Cover, pull out the Drum Unit completely and remove the jammed paper.

Paper jam inside the machine

User Check

- Check if the paper is jammed. If jammed, remove it.

Step	Cause	Remedy
1	Harness connection failure of registration front sensor PCB ASSY, registration rear sensor PCB ASSY or paper eject sensor PCB ASSY	Check the harness connections of the registration front sensor PCB ASSY, registration rear sensor PCB ASSY and paper eject sensor PCB ASSY, and reconnect them.
2	Registration front actuator, registration rear actuator or paper eject actuator not operating smoothly or catching in some position.	Correct smooth operation of the registration front actuator, registration rear actuator or paper eject actuator and ensure they are not catching in any positions.
3a	Paper eject sensor PCB failure	Check the sensor performance following the procedure described in "Maintenance mode 32". If any problem occurs, replace the fuser unit.
3b	Registration front sensor PCB failure (MP/ T1/ LT)	(MP/ T1) Check the sensor performance following the procedure described in "Maintenance mode 32". If any problem occurs, replace the front door unit ASSY.
		(LT) Check the sensor performance following the procedure described in "Maintenance mode 32". If any problem occurs, replace the LT paper feed frame unit.
3c	Registration rear sensor PCB failure	Check the sensor performance following the procedure described in "Maintenance mode 32". If any problem occurs, replace the front door unit ASSY.
4	Engine PCB failure	Replace the engine PCB ASSY.

■ **Error code 85**

No Tray
A Tray is not detected, install Tray 1.

Tray 1 (T1) is not installed into the machine.

User Check

- Check if tray 1 (T1) is installed into the machine.
- Check if the paper is jammed in tray 1 (T1).

Step	Cause	Remedy
1	T1 PE/edge sensor PCB failure	Check the sensor performance following the procedure described in "Maintenance mode 32". If any problem occurs, replace the T1 PE/edge sensor PCB ASSY.
2	Harness connection failure of T1 PE/edge sensor PCB ASSY	Check the harness connection of the T1 PE/edge sensor PCB ASSY and reconnect it.
3	Engine PCB failure	Replace the engine PCB ASSY.

■ **Error code 86 (MFC-9440CN/ 9450CDN only)**

No Tray

Tray 2 (LT) is not installed into the machine.

User Check

- Install Tray 2 (LT) into the machine.
- Select other tray than Tray 2.

Step	Cause	Remedy
1	Cassette sensor failure	Check the sensor performance following the procedure described in "Maintenance mode 32". If any problem occurs, replace the LT paper feed frame unit.

■ **Error code 89 (DCP-9042CDN/ MFC-9450CDN only)**

Size Error DX
Specify the correct paper and press start.

Incorrect paper size in duplex printing

User Check

- Use the letter size or longer paper.
- Do not use too thin paper.

Step	Cause	Remedy
1	Registration rear sensor PCB failure	Check the sensor performance following the procedure described in "Maintenance mode 32". If any problem occurs, replace the registration rear sensor PCB ASSY.

■ **Error code 8A (T1)**

Jam Tray 1
Remove the jammed paper from Tray 1.

Error code 8B (LT) (MFC-9440CN/ 9450CDN only)

Jam Tray 2
Remove the jammed paper from Tray 2.

Error code 8C (MP)

Jam MP Tray
Remove the jammed paper from Multi Purpose Tray and press start.

Paper jam in the appropriate tray

User Check

- Check if the paper is jammed in the appropriate tray. If jammed, remove it.
- Adjust the paper guide corresponding to the paper size.
- Check if too much paper is loaded in the tray.

Step	Cause	Remedy
1	Harness connection failure of registration front sensor PCB ASSY	Check the harness connection of the registration front sensor PCB ASSY in the appropriate tray, and reconnect it.
2	Paper feeding kit worn out (MP/ T1/ LT)	Replace the paper feeding kit of the appropriate tray.
3	Registration front sensor PCB failure (MP/ T1/ LT)	(MP/ T1) Check the sensor performance following the procedure described in "Maintenance mode 32". If any problem occurs, replace the front door unit ASSY. (LT) Check the sensor performance following the procedure described in "Maintenance mode 32". If any problem occurs, replace the LT paper feed frame unit.
4	Engine PCB failure	Replace the engine PCB ASSY.

■ **Error code 8E**

Registration
Registration failed. Press start and try again.

Auto color registration failure when implementing it from the control panel

Error code 8F

Registration
Registration failed. See Troubleshooting chapter in User's Guide.

Sensor sensitivity adjustment failure when implementing auto color registration from the control panel

Error code 9D

Registration
Registration failed. See Troubleshooting chapter in User's Guide.

Incorrect sensor measurement value when implementing auto color registration from the control panel

User Check

- Check if there is a scratch, dirt or the like on the belt unit. If there is, replace the belt unit with a new one.

Step	Cause	Remedy
1	Invisible damage on belt unit	Check the registration mark sensor performance following the procedure described in "Maintenance mode 75". If any problem occurs, replace the belt unit.
2	Harness connection failure of registration-mark sensor PCB ASSY	Check the harness connection of the registration-mark sensor PCB ASSY and reconnect it.
3	Registration-mark sensor PCB failure	Replace the registration-mark sensor PCB ASSY.
4	Transfer HVPS PCB unit failure	Replace the transfer HVPS PCB unit.
5	Engine PCB failure	Replace the engine PCB ASSY.

■ **Error code A1**

Cover is Open
Close the Front Cover.

Front cover opened

Step	Cause	Remedy
1	Front cover interlock switch failure	Check the sensor performance following the procedure described in "Maintenance mode 32". If any problem occurs, replace the front cover interlock switch ASSY.
2	Harness connection failure of front cover interlock switch ASSY	Check the harness connection of the front cover interlock switch ASSY and reconnect it.
3	Part pressing the front cover interlock switch is broken, which is provided at the left side of the front cover inside.	Replace the front door main or front door unit ASSY.
4	Engine PCB failure	Replace the engine PCB ASSY.

■ **Error code A2**

Document Jam.
Clear the scanner jam, then press the Stop Key.

The document is too long. (During scanning, 90 cm or longer of a document is detected.)

User Check

- Check if the document is jammed in the ADF. If jammed, remove it.

Step	Cause	Remedy
1	Document rear actuator not operating smoothly or catching in some position.	Correct smooth operation and that there is no catching of document rear actuator.

■ **Error code A3**

Document Jam.
Clear the scanner jam, then press the Stop Key.

Document rear sensor is not turned on when feeding the document.

User Check

- Check if the document is jammed in the ADF. If jammed, remove it.

Step	Cause	Remedy
1	Document rear actuator not operating smoothly or catching in some position.	Correct smooth operation and that there is no catching of document rear actuator.
2	Document rear sensor failure.	Replace the document rear sensor.

■ **Error code A5**

Unable to Scan
Remove the original document. Turn the power off, then on again.

Fax scanning error (The first warning only)

Step	Cause	Remedy
1	Scanning failure	Turn the power switch off and on. Then, try scanning again.

■ **Error code A6**

Unable to Scan
See Troubleshooting and routine maintenance chapter in User's Guide.

Fax scanning error (After the A5 error occurs, the same problem occurs again even though turning the power off and on.)

Step	Cause	Remedy
1	Scanner unit failure	Replace the FB unit.
2	Main PCB failure	Replace the main PCB ASSY.

■ **Error code A7**

Machine Error
Unplug machine, then call Brother.

There is no registration in scanning color parameter data.

Step	Cause	Remedy
1	Main PCB failure	Replace the main PCB ASSY.
2	FB unit failure	Replace the FB unit.

■ **Error code AD**

Unable to Scan
Remove the original document. Turn the power off, then on again.

DMA transfer error

Step	Cause	Remedy
1	Main PCB failure	Replace the main PCB ASSY.
2	Scanner unit failure	Replace the FB unit.

■ **Error code AE**

Unable to Scan
See Troubleshooting and routine maintenance chapter in User's Guide.

FB unit home position sensor is not turned on.

Step	Cause	Remedy
1	Scanner unit failure	Replace the FB unit.
2	Drive PCB failure	Replace the drive PCB.
3	Scanner motor failure	Replace the scanner motor.
4	Main PCB failure	Replace the main PCB ASSY.

■ **Error code AF**

Unable to Scan
See Troubleshooting and routine maintenance chapter in User's Guide.

FB unit home position sensor is not turned off.

Step	Cause	Remedy
1	Scanner unit failure	Replace the FB unit.
2	Drive PCB failure	Replace the drive PCB.
3	Scanner motor failure	Replace the scanner motor.
4	Main PCB failure	Replace the main PCB ASSY.

■ **Error code B0**

SCANNER ERROR

Harness for scanning is not connected correctly.

* This error is indicated on the LCD in the maintenance mode.

Step	Cause	Remedy
1	Scanner harness not connected correctly.	Reconnect the scanner harness correctly.
2	Scanner harness broken	Replace the FB unit. Replace the FFC cable ASSY.
3	Main PCB failure	Replace the main PCB ASSY.

■ **Error code B3**

SCANNER ERROR

Detection error of the scanning area on the left end

* This error is indicated on the LCD in the maintenance mode.

Step	Cause	Remedy
1	Scanner unit failure	Replace the FB unit.
2	Main PCB failure	Replace the main PCB ASSY.

■ **Error code B4**

SCANNER ERROR

Detection error of the scanning area on the right end

* This error is indicated on the LCD in the maintenance mode.

Step	Cause	Remedy
1	Scanner unit failure	Replace the FB unit.
2	Main PCB failure	Replace the main PCB ASSY.

■ **Error code B5**

SCANNER ERROR

Detection error of horizontal scanning edge reduction in scanning area setting

* This error is indicated on the LCD in the maintenance mode.

Error code B6

SCANNER ERROR

Detection error of horizontal scanning edge magnification in scanning area setting

* This error is indicated on the LCD in the maintenance mode.

Step	Cause	Remedy
1	White tape dirty of FB unit	Clean the white tape.
2	Scanner unit failure	Replace the FB unit.
3	Main PCB failure	Replace the main PCB ASSY.

■ **Error code B9**

SCANNER ERROR

Scanning light adjustment error is detected.

* This error is indicated on the LCD in the maintenance mode.

Step	Cause	Remedy
1	Scanner unit failure	Replace the FB unit.
2	Main PCB failure	Replace the main PCB ASSY.

■ **Error code BB**

SCANNER ERROR

White level data error

* This error is indicated on the LCD in the maintenance mode.

Step	Cause	Remedy
1	Scanner unit failure	Replace the FB unit.
2	Main PCB failure	Replace the main PCB ASSY.

■ **Error code BD**

SCANNER ERROR

Black level data error

* This error is indicated on the LCD in the maintenance mode.

Step	Cause	Remedy
1	Scanner unit failure	Replace the FB unit.
2	Main PCB failure	Replace the main PCB ASSY.

■ **Error code BE**

SCANNER ERROR

Detection error of scanning starting edge

* This error is indicated on the LCD in the maintenance mode.

Step	Cause	Remedy
1	Scanner unit failure	Replace the FB unit.
2	Main PCB failure	Replace the main PCB ASSY.

■ **Error code BF**

Unable to Scan.
Document is too long for duplex scanning. Press Stop key.

Longer document than the specified size is detected in duplex scanning.

Step	Cause	Remedy
1	Document front actuator 2 not operating smoothly or catching in some position.	Correct smooth operation and that there is no catching of the document front actuator 2.
2	Document front sensor 2 failure	Replace the document front sensor 2.

■ **Error code C0(K)**

Cartridge Error
Put the Black (K) Toner Cartridge back in.

Identification failure for a new toner cartridge (K)

Error code C1(Y)

Cartridge Error
Put the Yellow (Y) Toner Cartridge back in.

Identification failure for a new toner cartridge (Y)

Error code C2(M)

Cartridge Error
Put the Magenta (M) Toner Cartridge back in.

Identification failure for a new toner cartridge (M)

Error code C3(C)

Cartridge Error
Put the Cyan (C) Toner Cartridge back in.

Identification failure for a new toner cartridge (C)

User Check

- Install the toner cartridges into the machine properly.

Step	Cause	Remedy
1	Power off or front cover opened while detecting a new toner cartridge	Reset the developing bias voltage and develop roller counter. (Refer to "2.2 Develop Roller/ Developing Bias Voltage Counter Reset Function" in Chapter 5.)

■ **Error code C4 (MFC-9440CN/ 9450CDN only)**

Tray 2 Error

Take out Tray 2 and push it back in firmly.

Tray 2 (LT) plate-up function malfunction

User Check

- Check if Tray 2 (LT) is installed into the machine.

Step	Cause	Remedy
1	Connection failure between the machine and LT connector	Replace the connector.
2	Harness connection failure of plate motor ASSY LT	Check the harness connection of the plate motor ASSY LT and reconnect it.
3	Harness connection failure of LT paper feed frame unit	Check the harness connection of the LT paper feed frame unit and reconnect it.
4	LT paper feed frame unit failure	Check the sensor performance following the procedure described in "Maintenance mode 32". If any problem occurs, replace the LT paper feed frame unit.
5	Engine PCB failure	Replace the engine PCB ASSY.

■ **Error code C5**

EL Error

Open the Front Cover and close it again.

EL lamp electrifying failure

User Check

- Open and close the front cover.

Step	Cause	Remedy
1	Dirt on electrodes on drum unit and front cover	Clean both electrodes.
2	EL lamp PCB failure	Replace the drum unit.
3	EL lamp PCB harness broken	Replace the front door unit ASSY.
4	Engine PCB failure	Replace the engine PCB ASSY.

■ **Error code C6**

Toner Error

A Toner is not detected. Put all the Toner Cartridges back in correctly.

Toner cartridge mis-dividing

Step	Cause	Remedy
1	Harness connection failure of develop release motor	Check the harness connection of the develop release motor and reconnect it.
2	Develop release sensor PCB failure	Replace the develop release sensor PCB ASSY.
3	Engine PCB failure	Replace the engine PCB ASSY.

■ **Error code C8**

Out of Memory
Secure Print Data is full. Press Cancel and delete the previously stored data.

RAM area for secure data full

User Check

- Delete the stored data.

Step	Cause	Remedy
1	Main PCB failure	Replace the main PCB ASSY.

■ **Error code CA (MFC-9440CN/ 9450CDN only)**

Unusable Device
Remove the Device. Turn the power off and back on again.

Excess current to USB device

User Check

- Remove the USB device from the USB direct interface and turn the power off. Turn it on again after a while.
- Replace the USB device with another one.

Step	Cause	Remedy
1	Harness connection failure of USB host relay PCB ASSY	Check the harness connection of the USB host relay PCB ASSY and reconnect it.
2	USB host relay PCB failure	Replace the USB host relay PCB ASSY.
3	Main PCB failure	Replace the main PCB ASSY.
4	A device whose power consumption is out of the specification is inserted in the USB direct interface	Remove the device.

■ **Error code CB**

No Belt Unit
Open the Front Cover, pull out the Drum Unit completely and install the Belt Unit.

Belt unit is not installed into the machine.

User Check

- Check if the belt unit is installed into the machine.

Step	Cause	Remedy
1	Harness connection failure of density sensor holder ASSY	Check the harness connection of the density sensor holder ASSY and reconnect it.
2	Density sensor failure	Replace the density sensor holder ASSY.
3	Transfer HVPS PCB unit failure	Replace the transfer HVPS PCB unit.
4	Engine PCB failure	Replace the engine PCB ASSY.

■ **Error code CC**

No Fuser Unit
Install the Fuser Unit.

Fuser unit is not installed into the machine.

User Check

- Check if the fuser unit is installed into the machine.

Step	Cause	Remedy
1	Harness connection failure between fuser unit connector and engine PCB	Check the harness connection between the fuser unit connector and engine PCB, and reconnect it.
2	Engine PCB failure	Replace the engine PCB ASSY.
3	Main PCB failure	Replace the main PCB ASSY.

■ **Error code CD**

No Drum Unit
Install the Drum Unit.

Drum unit is not installed into the machine.

User Check

- Check if the drum unit is installed into the machine.

Step	Cause	Remedy
1	Dirt on electrodes on drum unit and front door unit ASSY	Clean both electrodes. (Refer to Fig. 1-1 and Fig 1-2 (P1-35) .)
2	Bending of front door unit ASSY electrode contact	Correct the electrode bending of the front door unit ASSY.
3	Harness connection failure between front door unit ASSY electrode and engine PCB ASSY	Check the harness connection between the front door unit ASSY electrode and engine PCB ASSY.
4	Engine PCB failure	Replace the engine PCB ASSY.

■ Electrodes location of the drum unit

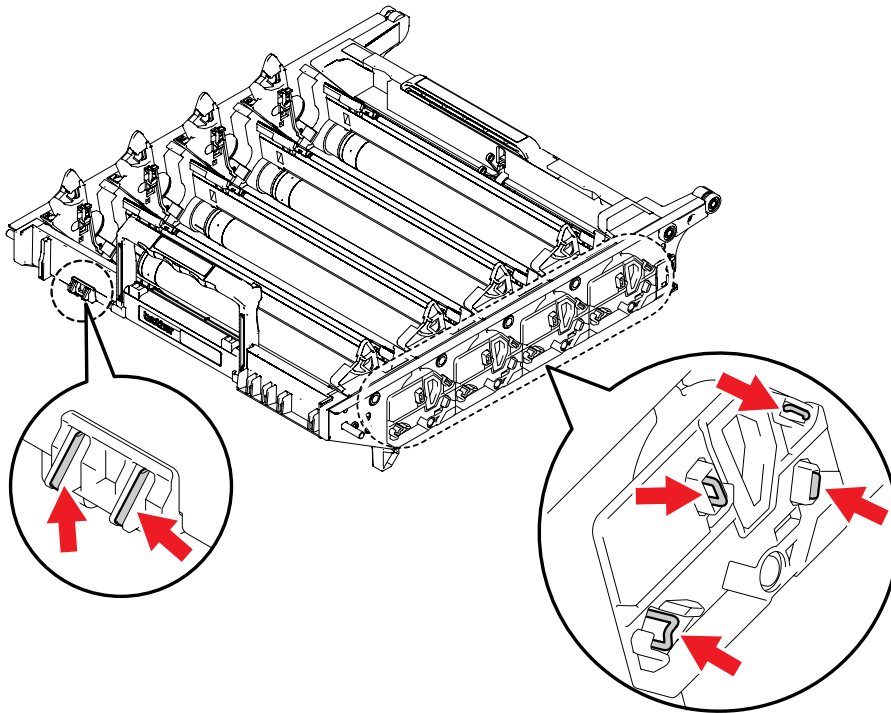

Fig. 1-1

■ Electrodes location of the front door unit ASSY

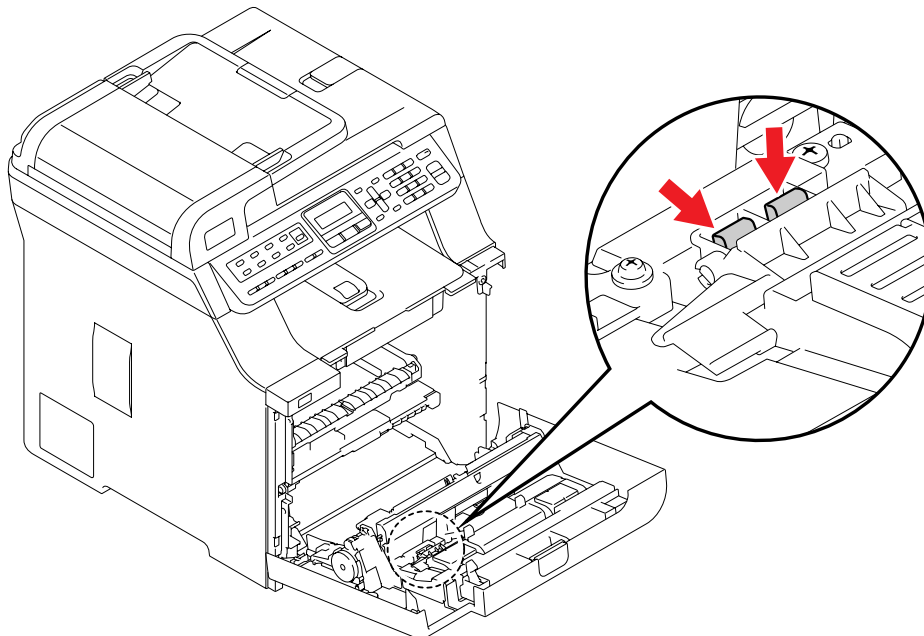

Fig. 1-2

<How to clean the electrodes>

Turn off the power switch. Unplug the machine from the AC power outlet, and leave the machine for a few minutes. Then, wipe the electrodes above carefully with a dry lint-free cloth. Be careful not to change the shapes of the electrodes.

■ Error code CE

No Waste Toner

Install the Waste Toner Box. Refer to the User's Guide for how to install.

Waste toner box is not installed into the machine.

User Check

- Check if the waste toner box is installed into the machine correctly.

Step	Cause	Remedy
1	Rotation defective of release shaft A of waste toner box.	Replace the waste toner box.
2	Harness connection failure between belt cleaner release sensor PCB and belt cleaner release solenoid.	Check the harness connection between the belt cleaner release sensor PCB and belt cleaner release solenoid and reconnect them.
3	Belt cleaner release sensor actuator performance defective	Replace the belt cleaner release ASSY.
4	Belt cleaner release sensor PCB failure	Check the sensor performance following the procedure described in "Maintenance mode 32". If any problem occurs, replace the belt cleaner release sensor PCB ASSY.
5	Belt cleaner release solenoid failure	Replace the belt cleaner release ASSY.
6	Engine PCB failure	Replace the engine PCB ASSY.

■ Error code CF

Waste Toner Full

Replace the Waste Toner Box. Refer to the User's Guide for how to do it.

Waste toner box full

User Check

- Replace the waste toner box with a new one.

Step	Cause	Remedy
1	Waste toner sensor failure	Check the sensor performance following the procedure described in "Maintenance mode 32". If any problem occurs, replace the waste toner near/full sensor ASSY.
2	Harness connection failure of waste toner near/full sensor ASSY	Check the harness connection of the waste toner near/full sensor ASSY and reconnect it.
3	Engine PCB failure	Replace the engine PCB ASSY.

■ Error code D0-DF

Press Stop Key

Modem error

User Check

- Turn the power switch off and on and check if the machine is recovered from the error.

Step	Cause	Remedy
1	Main PCB failure	Replace the main PCB ASSY.

■ **Error code E0**

Print Unable E0

Program error. (An error occurred in the ROM checksum.)

Step	Cause	Remedy
1	Firmware update failure	Upload the latest firmware.
2	Main PCB failure	Replace the main PCB ASSY.

■ **Error code E1**

Print Unable E1

Program error.

Step	Cause	Remedy
1	Firmware update failure	Upload the latest firmware.
2	Main PCB failure	Replace the main PCB ASSY.

■ **Error code E6**

Print Unable E6

Turn the power off and then back on again.

NVRAM error on main PCB

Step	Cause	Remedy
1	Main PCB failure	Replace the main PCB ASSY.

■ **Error code EB**

Print Unable EB

Turn the power off and then back on again.

NVRAM reading error on laser unit

Step	Cause	Remedy
1	Harness connection failure between laser unit and main PCB	Check the harness connection between the laser unit and main PCB and reconnect it.
2	Laser unit failure	Replace the laser unit.
3	Main PCB failure	Replace the main PCB ASSY.

■ **Error code EF**

Print Unable EF

Turn the power off and then back on again.

Incorrect print coverage value

User Check

- Turn the power off. Turn it on again after a while.

Step	Cause	Remedy
1	Main PCB failure	Replace the main PCB ASSY.

■ **Error code F8**

Machine Error F8

Battery connection failure

Step	Cause	Remedy
1	Battery harness connection failure	Reconnect the battery harness.
2	Main PCB failure	Replace the main PCB ASSY.

3. PAPER FEEDING PROBLEMS

Problems related to paper feeding are end user recoverable if following the User Check items. If the same problem occurs again, follow each procedure in the order of the number described in the Step column in the tables below.

3.1 No Feeding

Step	Cause	Check	Result	Remedy
1	Plate gear damaged	Is the plate gear damaged?	Yes	Replace the paper tray.
2	T1 edge actuator malfunction	Does T1 edge actuator move smoothly?	No	Re-assemble T1 edge actuator.
3	Disconnection of the paper feed solenoid harness	Is the harness of the paper feed solenoid disconnected?	Yes	Reconnect the harness.
4	Paper feed/belt cleaner motor failure	Is the problem solved by replacing the paper feed/belt cleaner motor?	Yes	Replace the paper feed/belt cleaner motor.

3.2 Double Feeding

Step	Cause	Check	Result	Remedy
1	Paper feeding kit	Is the surface of the separation pad worn out?	Yes	Replace the paper feeding kit.

3.3 Paper Jam

■ Paper jam in the paper tray and front cover

Step	Cause	Check	Result	Remedy
1	Belt unit malfunction	Does the belt unit move correctly?	No	Replace the belt unit.
2	Registration front actuator move smoothly or catching in some position	Does the registration front actuator move smoothly?	No	Re-assemble the registration front actuator.
3	T1 registration front sensor failure	Does T1 registration front sensor move smoothly? (Check it following the procedure described in "Maintenance mode 32".)	No	Replace the front door unit ASSY.

■ Paper jam in the back cover and paper eject section

Step	Cause	Check	Result	Remedy
1	Foreign object around fuser unit	Is there a foreign object around the fuser unit?	Yes	Remove the foreign object.
2	Paper eject ASSY malfunction	Is each pinch roller of the paper eject ASSY attached to each paper eject roller properly?	No	Replace the paper eject ASSY.
3	Paper eject actuator failure	Does the paper eject actuator move smoothly? Is it damaged?	No	Replace the fuser unit.

■ Paper jam in the DX paper feeding section

User Check

- Use the A4 size paper.
- Use paper which has not curled.
- Do not use too thin paper.
- Check that the DX paper size (A4/Letter) switch lever of the DX feed ASSY is placed in the correct position.

Step	Cause	Check	Result	Remedy
1	Deformation of paper guide DX on the bottom of the paper tray	Is the paper guide DX deformed?	No	Replace the paper tray.
2	DX feed ASSY failure	Is the DX feed ASSY deformed? Do the rollers of the DX feed ASSY move correctly?	No	Replace the DX feed ASSY.

3.4 Dirt on Paper

User Check

- Check if the paper is loaded into the paper tray correctly.
- Turn over the stack of paper in the paper tray, or try rotating the paper 180° in the paper tray.

Step	Cause	Check	Result	Remedy
1	Fuser unit dirty	Is there dirt around the entrance of the fuser unit?	Yes	Clean the entrance of the fuser unit.
		Is the pressure roller ASSY dirty?	Yes	Clean the pressure roller ASSY.
2	Dirt on belt unit electrode	Is the electrode of the belt unit dirty?	Yes	Clean the electrode of the main body and the belt unit.
3	Dirt on waste toner box electrode	Is the electrode of the waste toner box dirty?	Yes	Clean the electrode of the main body and the waste toner box.
4	Belt unit dirty	Does dirt on the paper disappear after replacing the belt unit with a new one?	Yes	Replace the belt unit.
5	Toner leak from the waste toner box	Is the waste toner box full of toner?	Yes	Replace the waste toner box. Check the near/full sensor ASSY. Or, replace the main PCB ASSY.

3.5 Wrinkles

User Check

- Check if the paper is loaded into the paper tray correctly.
- Turn over the stack of paper in the paper tray, or try rotating the paper 180° in the paper tray.

Step	Cause	Check	Result	Remedy
1	Fuser unit failure	Do wrinkles on the paper disappear after replacing the fuser unit with a new one?	Yes	Replace the fuser unit.

4. IMAGE DEFECT TROUBLESHOOTING

4.1 Image Defect Examples

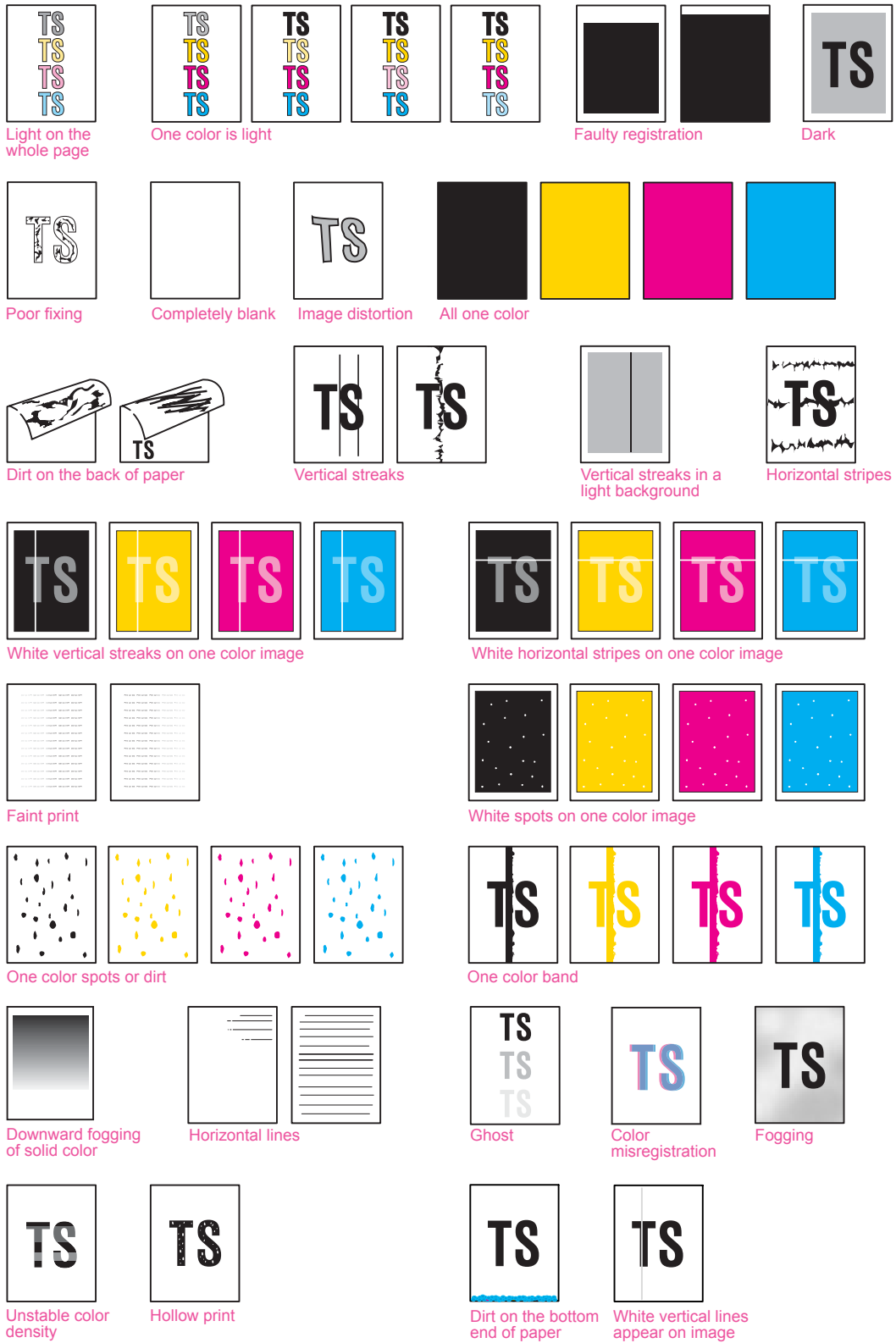

Fig. 1-3

4.2 Diameter of Rollers

Image defects which appear periodically may be caused by failure of a roller. Specify the cause referring to the diameters of the rollers or pitch which appears in the image as shown in the table below.

No.	Parts name	Diameter	The pitch which appears in the image
1	Develop roller	Ø 20.0 mm	37.4 mm
2	Exposure drum	Ø 24.0 mm	75.0 mm
3	Heat roller in the fuser unit	Ø 25.0 mm	78.5 mm
4	Pressure roller ASSY in the fuser unit	Ø 25.0 mm	78.5 mm

4.3 Troubleshooting Image Defect

Image defect related problems are end user recoverable if following the User Check items. If the same problem occurs, follow each procedure in the order of the number described in the Step column in the tables below.

■ Light on the whole page



User Check

- Check the machine's environment. High temperature and high humidity conditions can cause this problem.
- If the whole page is light, toner save mode may be on.
- Replace the toner cartridge or drum unit with a new one.
- Implement calibration from the control panel.

Step	Cause	Check	Result	Remedy
1	Transfer HVPS PCB failure	Is the transfer HVPS PCB ASSY connected correctly?	Yes	Replace the transfer HVPS PCB ASSY.
2	Engine PCB failure	Is the harness between the HVPS PCB and engine PCB connected correctly?	Yes	Replace the engine PCB ASSY.
3	Charge HVPS PCB failure	Is the harness of the HVPS PCB connected correctly?	Yes	Replace the charge HVPS PCB ASSY.
4	Laser unit failure	Is the problem solved after replacing the laser unit?	Yes	Replace the laser unit.

■ One color is light

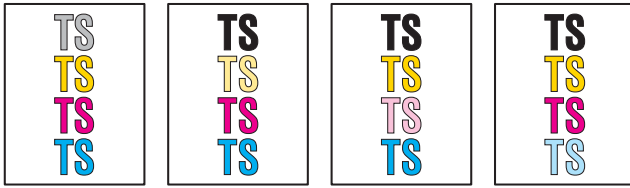

User Check

- Check the machine's environment. High temperature and high humidity conditions can cause this problem.
- Replace the toner cartridge or drum unit with a new one.
- Implement calibration from the control panel.

Step	Cause	Check	Result	Remedy
1	Dirt on exposure drum electrode	Are the electrodes of the drum unit and the appropriate color and machine body dirty?	Yes	Clean both electrodes.
2	Dirt on belt unit electrode	Are the electrodes of the belt unit and the appropriate color and machine body dirty?	Yes	Clean both electrodes.
3	Dirt on scanner windows	Is the scanner windows of the appropriate color dirty?	Yes	Wipe the dirt off with a soft, clean, lint free cloth.
4	Toner sensor failure	After replacing the toner cartridge of the appropriate color with a new one, does the same problem occur even after printing several pages?	No	Replace the toner cartridge of the appropriate color.
5		Does the machine start printing even after removing the toner cartridge of the appropriate color from the drum unit?	Yes	<ul style="list-style-type: none"> - Clean the toner sensor of the appropriate color. - Check the harness connection of the toner sensor PCB ASSY (TE/NEW) of the appropriate color. - Replace the toner sensor PCB ASSY (TE/NEW) of the appropriate color.
6	Transfer HVPS PCB failure	Is the problem solved after replacing the transfer HVPS PCB ASSY?	Yes	Replace the transfer HVPS PCB ASSY.
7	Charge HVPS PCB failure	Is the problem solved after replacing the charge HVPS PCB ASSY?	Yes	Replace the charge HVPS PCB ASSY.
8	Engine PCB failure	Is the problem solved after replacing the engine PCB ASSY?	Yes	Replace the engine PCB ASSY.

■ **Faulty registration**



Step	Cause	Check	Result	Remedy
1	Registration rear actuator operating smoothly or is it catching.	Does the registration rear actuator move smoothly?	No	Re-assemble the registration rear actuator.
2	Engine PCB failure	Is the problem solved after replacing the engine PCB ASSY?	Yes	Replace the engine PCB ASSY.

■ **Dark**



User Check

- Check the machine's environment. High temperature and high humidity conditions can cause this problem.
- Replace the toner cartridge or drum unit with a new one.
- Implement calibration from the control panel.

Step	Cause	Check	Result	Remedy
1	Corona wire conduction failure	Are the electrodes on the drum unit and machine body dirty?	Yes	Clean both electrodes.
2	Dirt on belt unit electrode	Are the electrodes on the belt unit and machine body dirty?	Yes	Clean both electrodes.
3	Transfer HVPS PCB failure	Is the problem solved after replacing the transfer HVPS PCB ASSY?	Yes	Replace the transfer HVPS PCB ASSY.
4	Charge HVPS PCB failure	Is the problem solved after replacing the charge HVPS PCB ASSY?	Yes	Replace the charge HVPS PCB ASSY.
5	Engine PCB failure	Is the harness connected between the HVPS PCB and engine PCB correctly?	Yes	Replace the engine PCB ASSY.

■ Poor fixing

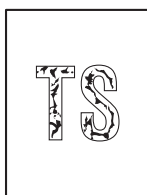

User Check

- Replace the drum unit with a new one.
- Replace the toner cartridge with a new one.
- Implement calibration from the control panel.

Step	Cause	Check	Result	Remedy
1	Fuser unit failure	Is the problem solved after replacing the fuser unit?	Yes	Replace the fuser unit.
2	Low-voltage power supply PCB failure	Is the problem solved after replacing the PS PCB unit?	Yes	Replace the PS PCB unit.
3	Transfer HVPS PCB failure	Is the problem solved after replacing the transfer HVPS PCB ASSY?	Yes	Replace the transfer HVPS PCB ASSY.
4	Charge HVPS PCB failure	Is the problem solved after replacing the charge HVPS PCB ASSY?	Yes	Replace the charge HVPS PCB ASSY.
5	Engine PCB failure	Is the problem solved after replacing the engine PCB ASSY?	Yes	Replace the engine PCB ASSY.

■ Completely blank



User Check

- Replace the toner cartridge or drum unit with a new one.

Step	Cause	Check	Result	Remedy
1	Developing bias voltage conduction failure	Are the electrodes on the drum unit and machine body dirty?	Yes	Clean both electrodes.
2	Scanner harness connection failure	Is the scanner harness connected securely?	No	Reconnect the scanner harness.
3	Engine PCB failure	Is the problem solved after replacing the engine PCB ASSY?	Yes	Replace the engine PCB ASSY.
4	Laser unit failure	Is the problem solved after replacing the Laser unit?	Yes	Replace the laser unit.
5	Transfer HVPS PCB failure	Is the problem solved after replacing the transfer HVPS PCB ASSY?	Yes	Replace the transfer HVPS PCB ASSY.
6	Charge HVPS PCB failure	Is the problem solved after replacing the charge HVPS PCB ASSY?	Yes	Replace the charge HVPS PCB ASSY.

■ Image distortion

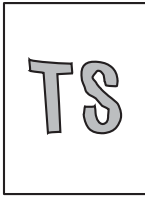

Step	Cause	Check	Result	Remedy
1	Laser unit not assembled correctly	Is the laser unit assembled into the machine securely? (Check if there is no gap.)	No	Assemble the laser unit correctly and secure the screw.
2	Incorrect radiation angle of scanner diode Scanner motor rotation failure	Is the problem solved after replacing the laser unit?	Yes	Replace the laser unit.

■ All one color

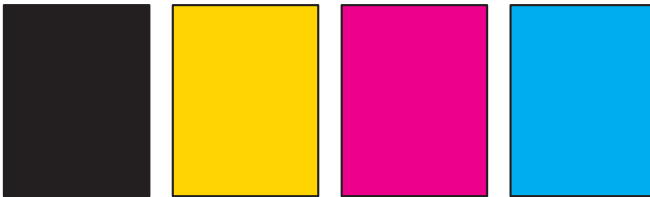

Step	Cause	Check	Result	Remedy
1	Corona wire failure	Are the electrodes on the drum unit of the appropriate color and machine body dirty?	Yes	Clean both electrodes.
2		Is the corona wire damaged?	Yes	Replace the drum unit.
3	Charge HVPS PCB failure	Is the problem solved after replacing the charge HVPS PCB ASSY?	Yes	Replace the charge HVPS PCB ASSY.
4	Main PCB failure	Is the problem solved after replacing the main PCB ASSY?	Yes	Replace the main PCB ASSY.
5	Engine PCB failure	Is the problem solved after replacing the engine PCB ASSY?	Yes	Replace the engine PCB ASSY.
6	Laser unit failure	Is the problem solved after replacing the laser unit?	Yes	Replace the laser unit.

■ Dirt on the back of paper

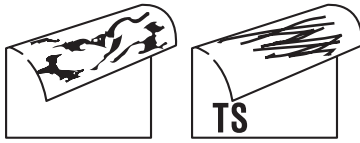

User Check

- If there is dirt on the back of the paper in duplex printing, the back of the paper tray may be dirty. Clean the back of the paper tray.

Step	Cause	Check	Result	Remedy
1	Fuser unit dirty	Is the pressure roller ASSY dirty? Is any other area in the machine dirty?	Yes	Print approximate 10 pages.
			No	Replace the fuser unit.
2	Dirt in the paper feed system	Is the paper tray or feed system on the drum unit dirty with toner?	Yes	Wipe dirt off.
3	Belt unit dirty	Is the problem solved by replacing the belt unit?	Yes	Replace the belt unit.
4	Waste toner box dirty	Is the problem solved by replacing the waste toner box?	Yes	Replace the waste toner box.

■ Vertical streaks

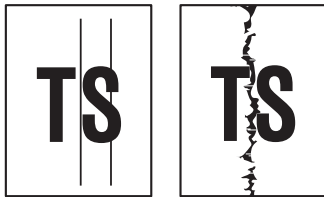

User Check

- This problem may occur with noise which is caused by dirt on the corona wire in the drum unit. In this case, clean the corona wire with the wire cleaner.
- Replace the drum unit with a new one.
- Replace the toner cartridge with a new one.

Step	Cause	Check	Result	Remedy
1	Dirt in the paper feed system	Is the paper tray or feed system on the drum unit dirty with toner?	Yes	Wipe dirt off.
2	Scratch on the exposure drum	Is there a scratch on the surface of the exposure drum?	Yes	Replace the drum unit.
3	Exposure drum dirty	Is there vertical dirt with toner on the surface of the exposure drum?	Yes	Replace the drum unit.
4	Scratch on the heat roller	Is there a scratch on the surface of the heat roller?	Yes	Replace the fuser unit

Note:

If the machine prints the same pattern, especially including vertical streaks, continuously, black vertical streaks may appear on the paper since the electrostatic performance of the exposure drum is decreased temporally.

■ Vertical streaks in a light background

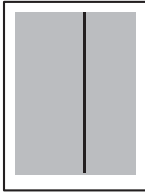

User Check

- Clean the inside of the machine and the corona wire in the drum unit.
- Replace the toner cartridge with a new one.

Step	Cause	Check	Result	Remedy
1	Drum unit failure	Is the problem solved after replacing the drum unit?	Yes	Replace the drum unit.

■ Horizontal stripes



User Check

- Clean the inside of the machine and the corona wire in the drum unit.
- Replace the drum unit with a new one.

Step	Cause	Check	Result	Remedy
1	Dirt on the charged electrode	Are the electrodes on the drum unit and machine body dirty?	Yes	Clean both electrodes
2	Paper tray ground terminal provided in the machine body	Is the paper tray ground terminal bent, which is provided in the machine body? (Refer to Fig. 1-4.)	Yes	Correct bending of paper tray ground terminal.
3	Toner attached on the develop roller	Are the horizontal stripes at 37.4 mm (develop roller circumference) intervals?	Yes	This problem will disappear by printing approximate 10 pages. If the same problem occurs, replace the toner cartridge.
4	Scratch on the exposure drum	Are the horizontal stripes at 75.0 mm (exposure drum circumference) intervals?	Yes	Replace the drum unit.
5	Scratch on the heat roller	Are the horizontal stripes at 78.5mm (heat roller circumference) intervals?	Yes	Replace the fuser unit.
6	Transfer HVPS PCB failure	Is the problem solved after replacing the transfer HVPS PCB ASSY?	Yes	Replace the transfer HVPS PCB ASSY.
7	Charge HVPS PCB failure	Is the problem solved after replacing the charge HVPS PCB ASSY?	Yes	Replace the charge HVPS PCB ASSY.

Paper tray ground terminal

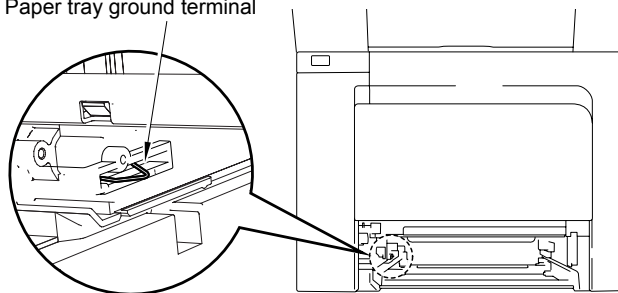

Fig. 1-4

■ **White vertical streaks on one color image**



User Check

- Clean the scanner windows of the appropriate color with a soft lint-free cloth.
- Check if there is no dust in the gap between the toner cartridge and drum frame.
- Replace the toner cartridge with a new one.
- Check the machine's environment. High temperature and high humidity conditions can cause this problem.
- Damp (wet) paper might be used. Try changing to fresh unopened paper.

Step	Cause	Check	Result	Remedy
1	Condensation	Has condensation occurred inside the machine?	Yes	Try to print several pages or leave the machine 2 hours to allow it to reach room temperature.
2	Transfer failure	Is the transfer roller of the appropriate color scratched?	Yes	Replace the drum unit.
3	Scanner windows failure	Is the problem solved after replacing the laser unit?	Yes	Replace the laser unit.

■ **White horizontal stripes on one color image**

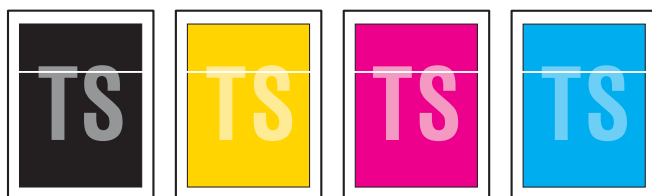

User Check

- Check that the appropriate media type is selected in the printer driver.
- The problem may disappear by itself. Try printing multiple pages to clear this problem especially if the machine has not been used for a long time.
- The drum unit may be damaged. Replace the drum unit with a new one.

Step	Cause	Check	Result	Remedy
1	Toner cartridge electrode connection failure	Are the electrodes on the toner cartridge and machine body dirty?	Yes	Clean both electrodes

■ Faint print

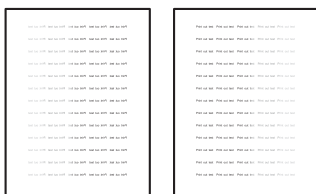

User Check

- Check that the machine is installed on a level surface.
- Replace the toner cartridge with a new one.
- Clean the scanner windows with a soft cloth.

Step	Cause	Check	Result	Remedy
1	Laser unit failure	Is the problem solved after replacing the laser unit?	Yes	Replace the laser unit.
2	Toner empty sensor failure	Is the "Toner Life End" message indicated on the LCD after replacing the current toner cartridge with an empty one?	No	Replace the toner sensor PCB ASSY (TE/NEW) of the appropriate color.

■ White spots on one color image

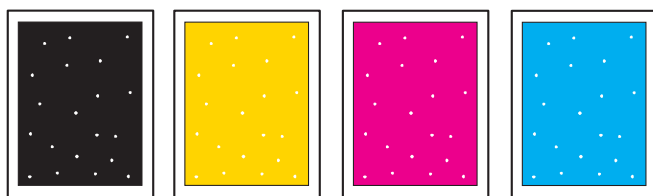

User Check

- Toner may be empty. Replace the toner cartridge with a new one.
- If the same problem occurs after printing a few pages, the adhesive of a label or the like, paper powder or dirt may be attached on the surface of the exposure drum. When the size of the white spots is less than 0.35mm, feed the drum cleaning sheet from the MP tray one to three times to clean the drum. (For the procedure, refer to "Drum Unit Cleaning Mode" in Chapter 5.) When the size of the spots is 0.35mm or more, or when the same problem occurs after feeding the drum cleaning sheet, wipe off the dirt on the exposure drum with a cotton swab. (For the procedure, refer to Note in the next pages.)
- The drum unit may be damaged. Replace the drum unit with a new one.

Step	Cause	Check	Result	Remedy
1	Drum unit failure	Are the white spots at 75.0 mm (exposure drum circumference) intervals?	Yes	If the exposure drum surface is scratched, replace the drum unit.
2	Drum unit connection failure	Are the electrodes on the drum unit and machine body dirty?	Yes	Clean both electrodes.
3	Transfer HVPS PCB failure	Is the problem solved after replacing the transfer HVPS PCB ASSY?	Yes	Replace the transfer HVPS PCB ASSY.
4	Charge HVPS PCB failure	Is the problem solved after replacing the charge HVPS PCB ASSY?	Yes	Replace the charge HVPS PCB ASSY.

Note:

If you have print quality problems, clean the drum unit as follows:

- (1) Pull the drum unit out of the machine and take all the toner cartridges out of the drum unit.
- (2) Turn the drum unit over by holding the handle. Make sure that the drum unit gears "1" are on the left hand.

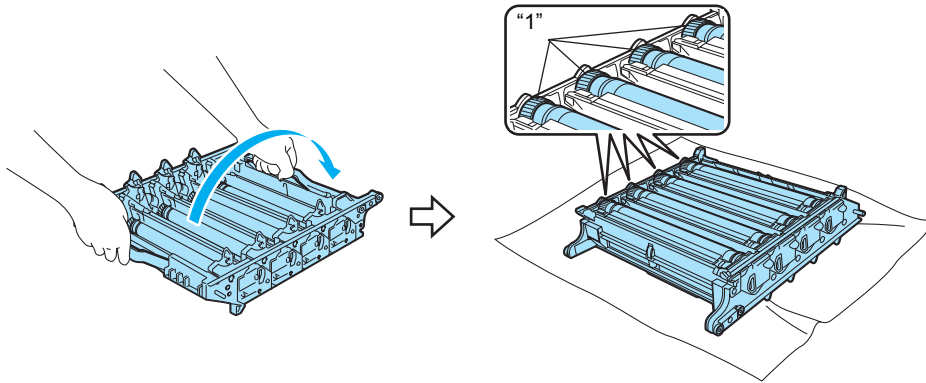

Fig. 1-5

Caution

We recommend that you place the drum unit on a clean, flat surface with a piece of disposable paper underneath it in case you accidentally spill or scatter toner.

- (3) See the print sample to identify the color causing the problem. The color of the spots is the color of the drum you should clean. For example, if the spots are cyan, you should clean the drum for cyan. Put the print sample in front of the drum, and find the exact position of the poor print.

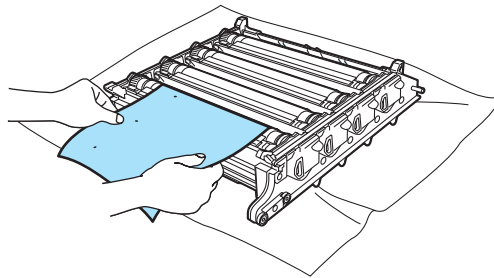

Fig. 1-6

- (4) Turn the drum unit gear to the direction of the arrow as shown in the figure below by hand while looking at the surface of the drum "1".

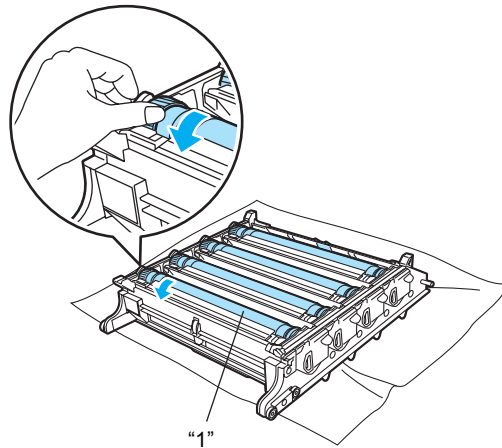

Fig. 1-7

- (5) When you have found the mark on the drum that matches the print sample, wipe the surface of the drum gently with a cotton swab until the dust or paper powder on the surface comes off.

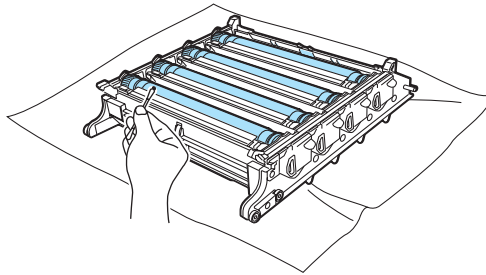

Fig. 1-8

Caution

DO NOT clean the surface of the photosensitive drum with a sharp object.

- (6) Turn the drum unit gear to the direction of the arrow as shown in the figure below by hand to return it to the home position. The home position of each drum can be identified by matching the number on the drum unit gear to the same number on the side of the drum unit as shown in the illustration. Make sure that the number on each of the four drum unit gears matches the corresponding number on the side of the drum unit.

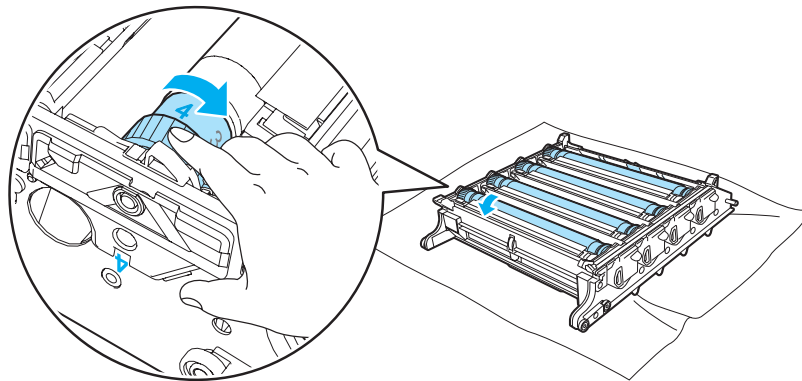
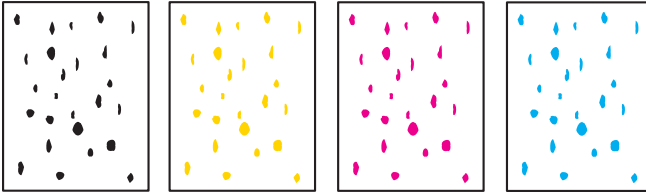

Fig. 1-9

■ One color spots or dirt



User Check

- Damp (wet) paper might be used. Try changing to freshly unopened paper.
- Toner may be empty. Replace the toner cartridge with a new one.
- If the same problem occurs after printing a few pages, the adhesive of a label or the like, paper powder or dirt may be attached on the surface of the exposure drum. Feed the drum cleaning sheet from the MP tray one to three times to clean the drum. (For the procedure, refer to "Drum Unit Cleaning Mode" in Chapter 5.)
When the same problem occurs after feeding the drum cleaning sheet, wipe off the dirt on the exposure drum with a cotton swab. (For the procedure, refer to Note in the previous pages.)
- The drum unit may be damaged. Replace the drum unit with a new one.

Step	Cause	Check	Result	Remedy
1	Drum unit failure	Are the spots at 75.0 mm (exposure drum circumference) intervals?	Yes	If the surface of the exposure drum is scratched, replace the drum unit.
2	Drum unit connection failure	Are the electrodes on the drum unit and machine body dirty?	Yes	Clean both electrodes
3	Fuser unit failure	Are the spots at 78.5mm (heat roller circumference) intervals?	Yes	Replace the fuser unit.
4	Transfer HVPS PCB failure	Is the problem solved after replacing the transfer HVPS PCB ASSY?	Yes	Replace the Transfer HVPS PCB ASSY.
5	Charge HVPS PCB failure	Is the problem solved after replacing the charge HVPS PCB ASSY?	Yes	Replace the charge HVPS PCB ASSY.

One color band



User Check

- Clean the inside of the machine and the corona wire in the drum unit. If the same problem occurs after cleaning, replace the drum unit with a new one.
- The paper tray ground terminal provided in the machine body may be dirty. Clean the contact with a dry cloth.

■ Downward fogging of solid color



User Check

- Toner may be empty. Replace the toner cartridge with a new one.

Step	Cause	Check	Result	Remedy
1	Transfer HVPS PCB failure	Is the problem solved after replacing the transfer HVPS PCB ASSY?	Yes	Replace the transfer HVPS PCB ASSY.
2	Charge HVPS PCB failure	Is the problem solved after replacing the charge HVPS PCB ASSY?	Yes	Replace the charge HVPS PCB ASSY.
3	Engine PCB failure	Is the problem solved after replacing the engine PCB ASSY?	Yes	Replace the engine PCB ASSY.

■ Horizontal lines

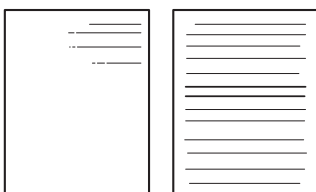

User Check

- The paper tray ground terminal provided in the machine body may be dirty. Clean the contact with a dry cloth.

Step	Cause	Check	Result	Remedy
1	Dirt on charged electrode	Are the electrodes on the drum unit and machine body dirty?	Yes	Clean both electrodes
2	Paper tray ground terminal provided in machine body	Is the paper tray ground terminal bent, which is provided in the machine body?	Yes	Correct bending of paper tray ground terminal.

■ Ghost



User Check

- Check the machine's environment, conditions such as high humidity may cause this situation to occur.
- Check that the appropriate media type is selected in the printer driver.
- Replace the drum unit with a new one.

Step	Cause	Check	Result	Remedy
1	Transfer HVPS PCB failure	Is the problem solved after replacing the transfer HVPS PCB ASSY?	Yes	Replace the transfer HVPS PCB ASSY.
2	Charge HVPS PCB failure	Is the problem solved after replacing the charge HVPS PCB ASSY?	Yes	Replace the charge HVPS PCB ASSY.
3	Engine PCB failure	Is the problem solved after replacing the engine PCB ASSY?	Yes	Replace the engine PCB ASSY.

■ Color misregistration



User Check

- Implement the auto color registration by the panel operation.
- Replace the belt unit with a new one.
- Replace the drum unit with a new one.
- Replace the waste toner box with a new one.

Step	Cause	Check	Result	Remedy
1	Phase shift of gear 39/121	Check if gear 39/121 phase is shifted?	Yes	Phase the Gear 39/121. For the method how to phase the gear 39/121, refer to "CHAPTER 3 DISASSEMBLY AND ASSEMBLY".
2	Engine PCB failure	Is the problem solved after replacing the engine PCB ASSY?	Yes	Replace the engine PCB ASSY.

■ Fogging



User Check

- Replace the toner cartridge with a new one.
- Replace the drum unit with a new one.
- Do not use acid paper.
- Check if there is dust or paper powder in the machine.

Step	Cause	Check	Result	Remedy
1	Toner sensor failure (Machine body)	Is the toner sensor performed normally by following the procedure described in "Maintenance mode 32" to check.	No	Replace the toner sensor PCB (TE/NEW) of the appropriate color.
2	Transfer HVPS PCB failure	Is the problem solved after replacing the transfer HVPS PCB ASSY?	Yes	Replace the Transfer HVPS PCB ASSY.
3	Charge HVPS PCB failure	Is the problem solved after replacing the charge HVPS PCB ASSY?	Yes	Replace the charge HVPS PCB ASSY.
4	Engine PCB failure	Is the problem solved after replacing the engine PCB ASSY?	Yes	Replace the engine PCB ASSY.

Note:

This problem often occurs when the drum unit or toner cartridge is nearly at the end of life.

■ Unstable color density



User Check

- Replace the belt unit with a new one.
- Replace the drum unit with a new one.
- Replace the waste toner box with a new one.
- Replace the toner cartridge with a new one.

Step	Cause	Check	Result	Remedy
1	Drum unit conduction failure	Are the electrodes on the drum unit and machine body dirty?	Yes	Clean both electrodes.
2	Toner cartridge electrode connection failure	Are the electrodes on the toner cartridge and machine body dirty?	Yes	Clean both electrodes.
3	Dirt on belt unit electrode	Are the electrodes on the belt unit and machine body dirty?	Yes	Clean both electrodes.
4	Main PCB failure	Is the problem solved after replacing the main PCB ASSY?	Yes	Replace the main PCB ASSY.
5	Engine PCB failure	Is the problem solved after replacing the engine PCB ASSY?	Yes	Replace the engine PCB ASSY.
6	Transfer HVPS PCB failure	Is the problem solved after replacing the transfer HVPS PCB ASSY?	Yes	Replace the transfer HVPS PCB ASSY.
7	Charge HVPS PCB failure	Is the problem solved after replacing the charge HVPS PCB ASSY?	Yes	Replace the charge HVPS PCB ASSY.
8	Laser unit failure	Is the problem solved after replacing the laser unit?	Yes	Replace the laser unit.

■ Hollow print



User Check

- Select the 'Thick paper mode' in the printer driver, or use thinner paper than you are currently using.
- Check the machine's environment, conditions such as high humidity may cause this situation to occur.

Step	Cause	Check	Result	Remedy
1	Fuser unit failure	Is the problem solved after replacing the fuser unit?	Yes	Replace the fuser unit.

■ Dirt on the bottom end of paper



Step	Cause	Check	Result	Remedy
1	Dirt on the bottom of drum unit	Is the bottom of drum unit dirty?	Yes	Wipe the dirt with a dry cloth as shown in Fig. 1-10.
2	Dirt on base shaft	Is the base shaft dirty?	Yes	Wipe the dirt with a dry cloth as shown in Fig. 1-11.

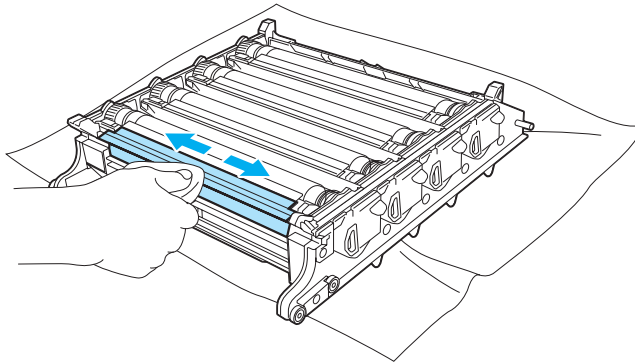
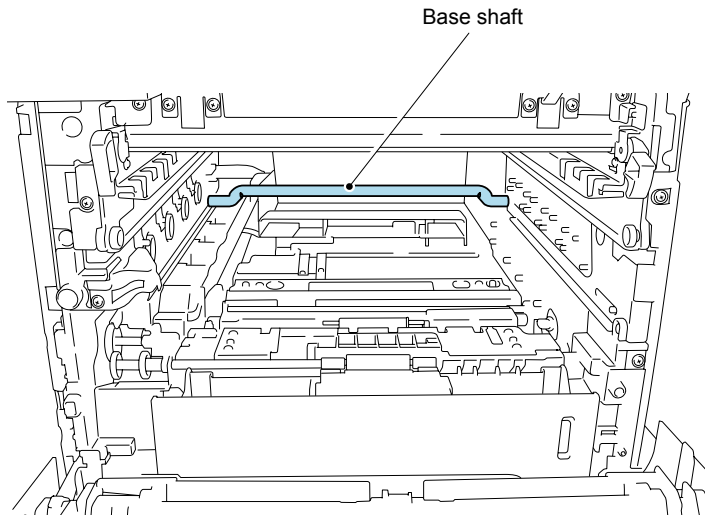

Fig. 1-10



* Figure of the front view

Fig. 1-11

■ White vertical lines appear on image



User Check

- Replace the toner cartridge or drum unit with a new one.

Step	Cause	Check	Result	Remedy
1	Dirt on fuser unit	Is the heat roller of the fuser unit dirty?	Yes	Clean the heat roller of the fuser unit.
2	Foreign substance or dirt on the paper feeding path	Is there any foreign substance or dirt on the paper feeding path?	Yes	Clean the paper feeding path.

5. SOFTWARE SETTING PROBLEMS

The machine may not print the data correctly if there are incorrect software settings.

User Check

- Check that the USB cable is not damaged.
- Check that the correct machine is selected if you have an interface switching device.
- Check the descriptions on the software setting in the user's guide.
- Try resetting the factory settings.

Step	Cause	Check	Result	Remedy
1	Failure inside the machine	Does the machine print test pattern? (Check it following the procedure described in "Maintenance mode 09".)	No	Identify the error type, and then refer to the specified section of this chapter.
2	Machine connection	For Macintosh, has the product ID been verified?	No	Verify the product ID. Product ID: DCP-9040CN: 01C9* DCP-9042CDN: 020C* MFC-9440CN: 01CA* MFC-9450CDN: 020D* * Hexadecimal
3	USB host relay PCB failure	Is the problem solved after replacing the USB host relay PCB ASSY?	Yes	Replace the USB host relay PCB ASSY.
4	Main PCB failure	Is the problem solved after replacing the main PCB ASSY?	Yes	Replace the main PCB ASSY.

6. NETWORK PROBLEMS

User Check

- Check the descriptions in the network user's guide.
- Try resetting the factory settings.

Step	Cause	Check	Result	Remedy
1	Main PCB failure	Is the problem solved after replacing the main PCB ASSY?	Yes	Replace the main PCB ASSY.

7. TROUBLESHOOTING OF THE COMMUNICATIONS ERROR

If a communications error occurs, the facsimile equipment

- (1) Gives the alarm (intermittent bleep) for approximately four seconds.
- (2) Indicates the appropriate error message on the LCD.
- (3) Prints the transmission report during fax transmission.

■ Definition of error codes on the communications list

(1) Calling

Code 1	Code 2	Causes
10	08	Wrong number called.
11	01	No dial tone detected before start of dialing.
11	02	Busy tone detected before dialing.
11	03	2nd dial tone not detected.
11	05	No loop current detected. *
11	06	Busy tone detected after dialing or called.
11	07	No response from the remote station in sending.
11	10	Unobtainable tone detected after dialing.
17	07	No response from the calling station in receiving.

* Available in German models only.

(2) Command reception

Code 1	Code 2	Causes
20	01	Unable to detect a flag field.
20	02	Carrier was OFF for 200 ms or longer.
20	03	Abort detected ("1" in succession for 7 bits or more).
20	04	Overrun detected.
20	05	A frame for 3 seconds or more received.
20	06	CRC error in answerback.
20	07	Error command received.
20	08	Invalid command received.
20	09	Command ignored once for document setting or for dumping-out at turn-around transmission.
20	0A	T5 time-out error
20	0B	CRP received.
20	0C	EOR and NULL received.
20	0C	EOR received.

(3) Communication code compatibility [checking the NSF and DIS]

1	Code 2	Causes
32	01	Remote terminal only with V.29 capability in 2400 or 4800 bps transmission.
32	02	Remote terminal not ready for polling.
32	10	Remote terminal not equipped with password function or its password switch OFF.
32	11	Remote terminal not equipped with or not ready for confidential mailbox function.
32	12	Remote terminal not equipped with or not ready for relay broadcasting function.
32	13	No confidential mail in the remote terminal.
32	14	The available memory space of the remote terminal is less than that required for reception of the confidential or relay broad-casting instruction.
32	18	Remote terminal not equipped with color function.

(4) Instructions received from the remote terminal [checking the NSC, DTC, NSS, and DCS]

Code 1	Code 2	Causes
40	02	Illegal coding system requested.
40	03	Illegal recording width requested.
40	05	ECM requested although not allowed.
40	06	Polled while not ready.
40	07	No document to send when polled.
40	10	Nation code or manufacturer code not correct.
40	13	Polled by any other manufacturers' terminal while waiting for secure polling.
40	17	Invalid resolution selected.
40	20	Invalid full color mode selected.

(5) Command reception [checking the NSF and DIS after transmission of NSS and DCS]

Code 1	Code 2	Causes
50	01	Vertical resolution capability changed after compensation of background color.

(6) ID checking

Code 1	Code 2	Causes
63	01	Password plus "lower 4 digits of telephone number" not coincident.
63	02	Password not correct.
63	03	Polling ID not correct.

(7) DCN reception

Code 1	Code 2	Causes
74		DCN received.

(8) TCF transmission/reception

Code 1	Code 2	Causes
80	01	Fallback impossible.

(9) Signal isolation

Code 1	Code 2	Causes
90	01	Unable to detect video signals and commands within 6 seconds after CFR is transmitted.
90	02	Received PPS containing invalid page count or block count.

(10) Video signal reception

Code 1	Code 2	Causes
A0	03	Error correction sequence not terminated even at the final transmission speed for fallback.
A0	11	Receive buffer empty. (5-second time-out)
A0	12	Receive buffer full during operation except receiving into memory.
A0	13	Decoding error continued on 500 lines or more.
A0	14	Decoding error continued for 10 seconds or more.
A0	15	Time-out: 13 seconds or more for one-line transmission.
A0	16	RTC not found or carrier OFF detected for 6 seconds.
A0	17	RTC found but no command detected for 60 seconds or more.
A0	19	No video data to be sent
A8	01	RTN, PIN, or ERR received at the calling terminal. *
A9	01	RTN, PIN, or ERR received at the called terminal. *
AA	18	Receive buffer full during receiving into memory.

* Available in German models only

(11) General communications-related

Code 1	Code 2	Causes
B0	02	Unable to receive the next-page data.
B0	03	Unable to receive polling even during turn-around transmission due to call reservation.
B0	04	PC interface error.
BF	01	Communication canceled by pressing the Stop/Exit button before establishment of FAX communication*.
BF	02	Communication canceled by pressing the Stop/Exit button after establishment of FAX communication*.
BF	03	Transmission canceled due to a scanning error caused by no document or document feed problem in ADF scanning in real time transmission.

* Establishment of FAX communication:

FAX communication is established when the calling station receives a DIS (reception capability) signal from the called station and the called station receives a NSS or DCS (communications test) signal from the calling station.

(12) Maintenance mode

Code 1	Code 2	Causes
E0	01	Failed to detect 1300 Hz signal in burn-in operation.
E0	02	Failed to detect PB signals in burn-in operation.

(13) Equipment error

Code 1	Code 2	Causes
FF	<u>X X</u>	Equipment error (For X X, refer to "2.1 Error Indication")

8. TROUBLESHOOTING OF THE CONTROL PANEL

■ Nothing is displayed on the LCD.

User Check

- Verify if the power switch is turned off.
- Pull out the power supply cord from the power outlet and leave it for 5 minutes or more. Then, insert it to the power outlet again and turn on the power supply.

Step	Possible cause	Check	Result	Remedy
1	Connection between main PCB and control panel PCB	Are the main PCB and control panel PCB connected properly?	No	Reconnect the connector properly.
2	Harness between main PCB and control panel PCB	Is the harness damaged?	Yes	Replace the harness with a normal one.
3	Connection between main PCB and PS PCB unit	Are the main PCB and PS PCB unit connected properly?	No	Reconnect the connector properly.
4	Harness between main PCB and PS PCB unit	Is the harness damaged?	Yes	Replace the harness with a normal one.
5	LCD	Is the problem solved after replacing the LCD?	Yes	Replace the LCD.
6	Control panel PCB	Is the problem solved after replacing the control panel PCB?	Yes	Replace the control panel PCB.
7	PS PCB unit	Is the problem solved after replacing the PS PCB unit?	Yes	Replace the PS PCB unit.
8	Main PCB	Is the problem solved after replacing the main PCB ASSY?	Yes	Replace the main PCB ASSY.

■ The control panel does not work.

Step	Possible cause	Check	Result	Remedy
1	Key sticking	Is there a key on the control panel stuck?	Yes	Clean up the panel cover, or remove the burrs from panel cover and panel keys.
2	Connection between main PCB and control panel PCB	Are the main PCB and control panel PCB connected properly?	No	Reconnect the connector properly.
3	Harness between main PCB and control panel PCB	Is the harness damaged?	Yes	Replace the harness with a normal one.
4	Rubber Key	Is the problem solved after replacing the rubber key?	Yes	Replace the rubber Key.
5	Control panel PCB	Is the problem solved after replacing the control panel PCB?	Yes	Replace the control panel PCB.
6	Main PCB	Is the problem solved after replacing the main PCB ASSY?	Yes	Replace the main PCB ASSY.

■ Printing from Macintosh applications fails.

User Check

- Check that the printer driver which, is supplied with the product, is installed in Library/ Printers, and that the print queue is created.
- Check the connecting end on the printer browser. It must be matched with the connecting end which is actually connected.

Step	Possible cause	Check	Result	Remedy
1	Failure inside the machine	Does the machine print test pattern? (Check it following the procedure described in "Maintenance mode 09".)	No	Identify the error type, and then refer to the specified section of this chapter.
2	Breakage of main PCB	Does the machine make a print using a correct PC and a USB cable?	No	Replace the main PCB ASSY.

9. TROUBLESHOOTING OF FAX FUNCTIONS

■ FAX can't send it.

User Check

- Verify that the telephone cord is securely inserted.

Step	Possible cause	Check	Result	Remedy
1	Dialing mode Setting	Does a dialing signal (PB or DP) come out normally in each mode? (Use telephone line emulator.)	Yes	Check the dialing mode setting at customer's again. Check the telephone line cord between machine and socket.
2	Connection between main PCB and NCU PCB	Are the main PCB and NCU PCB connected properly?	No	Reconnect the connector properly.
3	Harness between main PCB and NCU PCB	Is the harness damaged?	Yes	Replace the harness with a normal one.
4	Connection between main PCB and control panel PCB	Are the main PCB and control panel PCB connected properly?	No	Reconnect the connector properly.
5	Harness between main PCB and control panel PCB	Is the harness damaged?	Yes	Replace the harness with a normal one.
6	Contact of rubber key	Does the rubber key work correctly?	No	Replace the rubber Key.
7	NCU PCB	Is the problem solved after replacing the NCU PCB ASSY?	Yes	Replace the NCU PCB ASSY.
8	Control panel PCB	Is the problem solved after replacing the control panel PCB?	Yes	Replace the control panel PCB.
9	Main PCB	Is the problem solved after replacing the main PCB ASSY?	Yes	Replace the main PCB ASSY.

■ Speed dialing and One-touch dialing can't be used.

Step	Possible cause	Check	Result	Remedy
1	Speed dialing keys or one-touch dialing keys	Can a fax transmission be made using the numeric keys?	Yes	Replace the main PCB ASSY.
2	Dialing mode Setting	Does a dialing signal (PB or DP) come out normally in each mode? (Use telephone line emulator.)	Yes	Check the dialing mode setting at customer's again. Check the telephone line cord between machine and socket.
3	Connection between main PCB and NCU PCB	Are the main PCB and NCU PCB connected properly?	No	Reconnect the connector properly.
4	Harness between main PCB and NCU PCB	Is the harness damaged?	Yes	Replace the harness with a normal one.
5	Connection between main PCB and control panel PCB	Are the main PCB and control panel PCB connected properly?	No	Reconnect the connector properly.
6	Harness between main PCB and control panel PCB	Is the harness damaged?	Yes	Replace the harness with a normal one.
7	Contact of rubber key	Is the problem solved after replacing the rubber key?	No	Replace the rubber Key.
8	NCU PCB	Is the problem solved after replacing the NCU PCB ASSY?	Yes	Replace the NCU PCB ASSY.
9	Control panel PCB	Is the problem solved after replacing the control panel PCB?	Yes	Replace the control panel PCB.

■ FAX can't be received.

User Check

- Verify that the telephone cord is securely inserted.

Step	Possible cause	Check	Result	Remedy
1	Receive mode setting	Is the receive mode set to automatic receive mode?	No	Set the receive mode to automatic receive mode.
2	NCU PCB	Is the problem solved after replacing the NCU PCB ASSY?	Yes	Replace the NCU PCB ASSY.
3	Main PCB	Is the problem solved after replacing the main PCB ASSY?	Yes	Replace the main PCB ASSY.

■ No bell ring.

Step	Possible cause	Check	Result	Remedy
1	Ring delay	Ring delay is set to "0".	Yes	Change the ring delay settings to another value.
2	Ring volume	Ring volume is set to "OFF".	Yes	Change the ring volume setting to another value.
3	Connection between main PCB and NCU PCB	Are the main PCB and NCU PCB connected properly?	No	Reconnect the connector properly.
4	Harness between main PCB and NCU PCB	Is the harness damaged?	Yes	Replace the harness with a normal one.
5	Speaker	Is the problem solved after replacing the speaker?	Yes	Replace the Speaker.
6	NCU PCB	Is the problem solved after replacing the NCU PCB ASSY?	Yes	Replace the NCU PCB ASSY.
7	Main PCB	Is the problem solved after replacing the main PCB ASSY?	Yes	Replace the main PCB ASSY.

■ Speaker is silent during on-hook dialing.

Step	Possible cause	Check	Result	Remedy
1	Connection between main PCB and speaker	Are the main PCB and speaker connected properly?	No	Reconnect the connector properly.
2	Speaker	Is the problem solved after replacing the speaker?	Yes	Replace the Speaker.
3	Connection between main PCB and NCU PCB	Are the main PCB and NCU PCB connected properly?	No	Reconnect the connector properly.
4	Harness between main PCB and NCU PCB	Is the harness damaged?	Yes	Replace the harness with a normal one.
5	Connection between main PCB and control panel PCB	Are the main PCB and control panel PCB connected properly?	No	Reconnect the connector properly.
6	Harness between main PCB and control panel PCB	Is the harness damaged?	Yes	Replace the harness with a normal one.
7	NCU PCB	Is the problem solved after replacing the NCU PCB ASSY?	Yes	Replace the NCU PCB ASSY.
8	Main PCB	Is the problem solved after replacing the main PCB ASSY?	Yes	Replace the main PCB ASSY.

■ Dialing function does not switch between "tone" and "pulse".

Step	Possible cause	Check	Result	Remedy
1	Connection between main PCB and NCU PCB	Are the main PCB and NCU PCB connected properly?	No	Reconnect the connector properly.
2	Harness between main PCB and NCU PCB	Is the harness damaged?	Yes	Replace the harness with a normal one.
3	NCU PCB	Is the problem solved after replacing the NCU PCB ASSY?	Yes	Replace the NCU PCB ASSY.
4	Main PCB	Is the problem solved after replacing the main PCB ASSY?	Yes	Replace the main PCB ASSY.

10. OTHERS PROBLEMS

■ **The machine is not turned on, or the LCD indication does not appear.**

User Check

- Pull out the power supply cord from the power outlet and leave it for 5 minutes or more. Then, insert it to the power outlet again and turn on the power supply.

Step	Cause	Check	Result	Remedy
1	Harness connection failure of LCD panel PCB	Is the harness of the LCD panel PCB ASSY connected correctly?	No	Reconnect the LCD panel PCB ASSY harness
2	LCD panel PCB failure	Is the problem solved after replacing the LCD panel PCB ASSY?	Yes	Replace the LCD panel PCB ASSY.
3	LCD panel failure	Is the problem solved after replacing the LCD panel ASSY?	Yes	Replace the LCD panel ASSY.
4	Low-voltage power supply failure	Is the problem solved after replacing the PS PCB unit?	Yes	Replace the PS PCB unit.
5	Main PCB	Is the problem solved after replacing the main PCB ASSY?	Yes	Replace the main PCB ASSY.

■ **The fan does not work.**

(Verify the position of each fan referring to "1.4.22 Operational Check of Fans (Function code 78)" in Chapter 5.)

Step	Cause	Check	Result	Remedy
1	Harness connection failure of the appropriate fan	Is the harness of the appropriate fan connected correctly?	No	Reconnect the harness of the appropriate fan correctly.
2	Charge HVPS PCB failure	Is the problem solved after replacing the charge HVPS PCB ASSY?	Yes	Replace the charge HVPS PCB ASSY. Replace the fuser unit fan (FU) and air intake fan (AIR).
3	Low-voltage power supply failure	Is the problem solved after replacing the PS PCB unit?	Yes	Replace the PS PCB unit. Replace the LVPS fan (PS).
4	Engine PCB failure	Is the problem solved after replacing the engine PCB ASSY?	Yes	Replace the engine PCB ASSY. Replace the drum unit fan (OPC).
5	Main PCB	Is the problem solved after replacing the main PCB ASSY?	Yes	Replace the main PCB ASSY.

■ Pickup function of paper tray does not work.

Step	Cause	Remedy
1	Link lever not operating smoothly or catching.	Make sure correct movement of the link lever.
2	Pickup roller holder ASSY not operating smoothly or catching.	Make sure correct movement of the pickup roller holder ASSY.
3	Link lever damaged	Replace the link lever.
4	Roller holder ASSY failure	Replace the roller holder ASSY.
5	Paper feed/belt cleaner motor failure	Replace the paper feed/belt cleaner motor.

■ The new toner is not detected.

Step	Cause	Remedy
1	New toner actuator not operating smoothly or catching.	Make sure correct movement of the new toner actuator of the appropriate color.
2	New toner actuator damaged	Replace the drum unit.
3	Main PCB failure	Replace the main PCB ASSY.
4	Toner sensor PCB (TE/NEW) failure	Replace the toner sensor PCB ASSY (TE/NEW) of the appropriate color.

CHAPTER 2 PERIODICAL MAINTENANCE

To avoid creating secondary problems by mishandling, follow the warnings below during maintenance work.

⚠ WARNING

- Always turn off the power switch and unplug the power cord from the power outlet before accessing any parts inside the machine.
- When opening the front cover or back cover to access any parts inside the machine, never touch the shaded parts shown in the following figures.

1. CONSUMABLE PARTS

The consumable parts described in this section are parts which are subject to deterioration or damage and should be replaced at least once during the period of warranty of the product if any printing quality problem appears.

Parts			Approximate Life
Toner Cartridge	Black	Standard cartridge	Approx. 2,500 pages A4/Letter pages @ 5% coverage
		High-capacity cartridge	Approx. 5,000 pages A4/Letter pages @ 5% coverage
	Cyan, Magenta, Yellow	Standard cartridge	Approx. 1,500 pages A4/Letter pages @ 5% coverage
		High-capacity cartridge	Approx. 4,000 pages A4/Letter pages @ 5% coverage
Drum Unit			Approx. 17,000 pages A4/Letter pages Life expectancy will vary depending on number of continuous printing pages. (Refer to "Life of Drum Unit" .)
Belt Unit			Approx. 50,000 pages A4/Letter pages Life expectancy will vary depending on number of continuous printing pages. (Refer to "Life of Belt Unit" .)
Waste Toner Box			Approx. 20,000 pages A4/Letter pages @ 5% coverage for CMYK each

■ Life of Drum Unit

<How to read the drum unit life>

- It initially indicates 100% and gradually decreases.
- It indicates 0% when the “Drum End Soon” appears on the LCD.
- It stays at 0% even if further printing is done.

<How to calculate the drum unit life>

The drum unit life is based on the “drum counter” or the “number of drum rotations”.

The drum counter is based on the total printed pages on each drum unit. This total printed pages should be reset every time you replace the drum unit with a new one. (Refer to “2.3 Parts Life Reset Function” in this chapter.) Basically this amount is equal to the assured printable pages of the drum unit.

If the developing bias voltage correction or color registration adjustment is performed frequently, however, only the number of drum rotations increases, and the “page counter based on the number of drum rotation” exceeds the “drum counter” based on the total printed page.

Refer to the calculation of the drum unit life based on the number of drum rotation below;

<How to calculate the page counter>

The number of drum rotations for the first page printed is about 27. The number of drum rotations per one page for the second or later page printed (continuous printing) is 4.6. Using these figures, the page counter is calculated as follows:

Page counter based on the number of drum rotations = (Number of drum rotations for the first page printed + (Number of drum rotations per one page for the second or later page printed x (Number of pages in continuous printing - 1))) / 27

(* The number of drum rotations per one page continuous printing.)

Example: Starts to print when the machine is in the Ready state.

Continuous printing	Page counter based on the number of drum rotations (Pages)
1 page/job	$(27 + (4.6 \times (1 - 1))) / 27 = 1$
2 pages/job	$(27 + (4.6 \times (2 - 1))) / 27 = 1.17$
18 pages/job	$(27 + (4.6 \times (18 - 1))) / 27 = 3.89$

If you leave the machine without printing for a long time, the number of drum rotations is increasing because the developing bias voltage correction and the color registration are performed. If you print one page per one job every time after leaving the machine without printing for a long time, the drum unit life is shorter than usual.

The number of drum rotations required for the developing bias voltage correction = 40 rotations.

Example: Performs the developing bias voltage correction and starts to print after leaving the machine without printing for a long time.

Continuous printing	Page counter based on the number of drum rotations (Pages)
1 page/job	$(40 + 27 + (4.6 \times (1 - 1))) / 27 = 2.48$
2 pages/job	$(40 + 27 + (4.6 \times (2 - 1))) / 27 = 2.65$
18 pages/job	$(40 + 27 + (4.6 \times (18 - 1))) / 27 = 5.37$

The number of drum rotations required for the color registration = 104 rotations

Example: Performs the color registration adjustment and starts to print after leaving the machine without printing for a long time.

Continuous printing	Page counter based on the number of drum rotations (Pages)
1 page/job	$(104 + 27 + (4.6 \times (1 - 1))) / 27 = 4.85$
2 pages/job	$(104 + 27 + (4.6 \times (2 - 1))) / 27 = 5.02$
18 pages/job	$(104 + 27 + (4.6 \times (18 - 1))) / 27 = 7.75$

If the developing bias voltage correction and the color registration are performed continuously, the drum unit life is shorter.

■ Life of Belt Unit

The belt unit life is decided according to the page counter based on the actual “number of belt rotations”.

<How to calculate the page counter>

The page counter based on the number of belt rotations is calculated as follows:

Page counter based on the number of belt rotations = (Number of belt rotations for the first page printed + (Number of belt rotations per one page for the second or later page printed x (Number of pages in continuous printing - 1))) / 1.25

The number of belt rotations for the first page printed is 3.6.

The number of belt rotations per one page for the second or later page printed is 0.63.

The number of belt rotations per one page in printing five pages continuously is 1.25.

Example: Starts to print when the machine is in the ready state.

Continuous printing	Page counter based on the number of belt rotations (Pages)
1 page/job	$(3.6 + (0.63 \times (1 - 1))) / 1.25 = 2.88$
2 pages/job	$(3.6 + (0.63 \times (2 - 1))) / 1.25 = 3.38$
18 pages/job	$(3.6 + (0.63 \times (18 - 1))) / 1.25 = 11.45$

If you leave the machine without printing for a long time, the number of belt rotations is increasing because the developing bias voltage correction and the color registration are performed. If you print one page per one job every time after leaving the machine without printing for a long time, the belt unit life is shorter than usual.

The number of belt rotations required for the developing bias voltage correction = 5.3 rotations.

Example: Performs the developing bias voltage correction and starts to print after leaving the machine without printing for a long time.

Continuous printing	Page counter based on the number of belt rotations (Pages)
1 page/job	$(5.3 + 3.6 + (0.63 \times (1 - 1))) / 1.25 = 7.12$
2 pages/job	$(5.3 + 3.6 + (0.63 \times (2 - 1))) / 1.25 = 7.62$
18 pages/job	$(5.3 + 3.6 + (0.63 \times (18 - 1))) / 1.25 = 15.69$

The number of belt rotations required for the color registration = 14 rotations

Example: Performs the color registration adjustment and starts to print after leaving the machine without printing for a long time.

Continuous printing	Page counter based on the number of belt rotations (Pages)
1 page/job	$(14 + 3.6 + (0.63 \times (1 - 1))) / 1.25 = 14.08$
2 pages/job	$(14 + 3.6 + (0.63 \times (2 - 1))) / 1.25 = 14.58$
18 pages/job	$(14 + 3.6 + (0.63 \times (18 - 1))) / 1.25 = 22.65$

If the developing bias voltage correction and the color registration are performed continuously, the drum unit life is shorter.

2. PERIODICAL REPLACEMENT PARTS

2.1 Periodical Replacement Parts

Periodical replacement parts are the parts to be replaced periodically to maintain product quality. These parts would affect the product quality if they lose their functionality even if they do not appear to be damaged or there is no change in their appearance.

The periodical replacement parts listed in the table below should be replaced according to the service life.

Parts Name	LCD	Q'ty	Approximate Life	Replacement Procedure
Fuser unit & Toner filter frame ASSY	Fuser Unit	1	80,000 pages	Refer to 2.2.1 .
Laser unit	Laser Unit	1	100,000 pages	Refer to 2.2.2 .
Paper feeding kit ^{*1}	PF Kit1, PF Kit2	1	100,000 pages	Refer to 2.2.3 .
MP paper feeding kit ^{*2}	PF KitMP	1	50,000 pages	Refer to 2.2.4 .

^{*1}: The paper feeding kit includes the separation pad ASSY, separation pad spring and roller holder ASSY.

^{*2}: MP Paper feeding kit includes the separation pad ASSY MP, separation pad spring MP, and MP roller holder ASSY.

When replacing the periodical replacement parts, each of the counters need to be reset in order to count the number of replacement times. Refer to [“2.3 Parts Life Reset Function”](#) in this chapter.

Also make sure to wipe the dirt on the drum unit as shown in the figure below when replacing each of the periodical replacement parts.

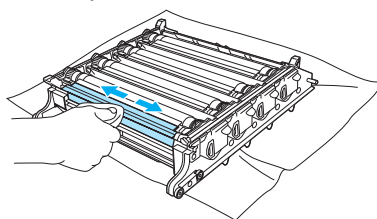

The number of printed pages of the machine can be checked by accessing the machine's log information on the LCD. (Refer to [“1.4.23 Display of the Machine's Log Information”](#) (Function code 80) in Chapter 5.) The actual number of printed page will vary depending on the type of print job or the paper to be used. The figures indicated as the approximate life in the table above are worked out when printing a general business document (with 5% print coverage) on one side of A4-size paper.

Note:

- Always turn off the power switch of the machine and unplug the power cord from the power outlet before replacing the periodical replacement parts.
- If the fuser unit is replaced after errors related to the fuser unit occur, it is necessary to leave the machine power ON for ten minutes after part replacement. This will make the machine to be released from errors.
- After disconnecting flat cables, check that each cable is not damaged at its end or short-circuited.
- When connecting flat cables, do not insert them at an angle. After insertion, check that the cables are not at an angle.

2.2 Procedures to Replace Periodical Replacement Parts

2.2.1 Fuser Unit & Toner Filter Frame ASSY

<Uninstalling Procedure>

- (1) Open the Back cover.

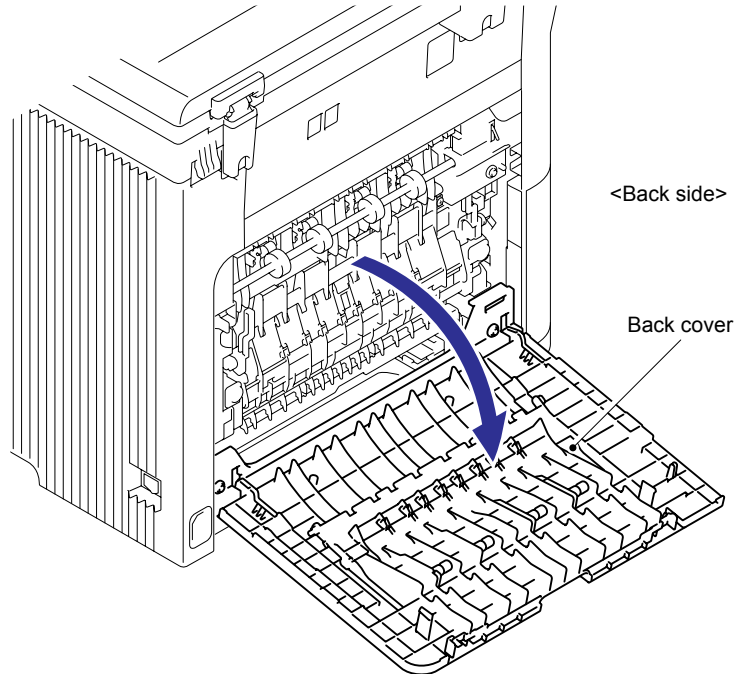

Fig. 2-1

- (2) Remove the two pan B M4x14 Taptite screws, and then pull out the Fuser unit to the back of the machine.

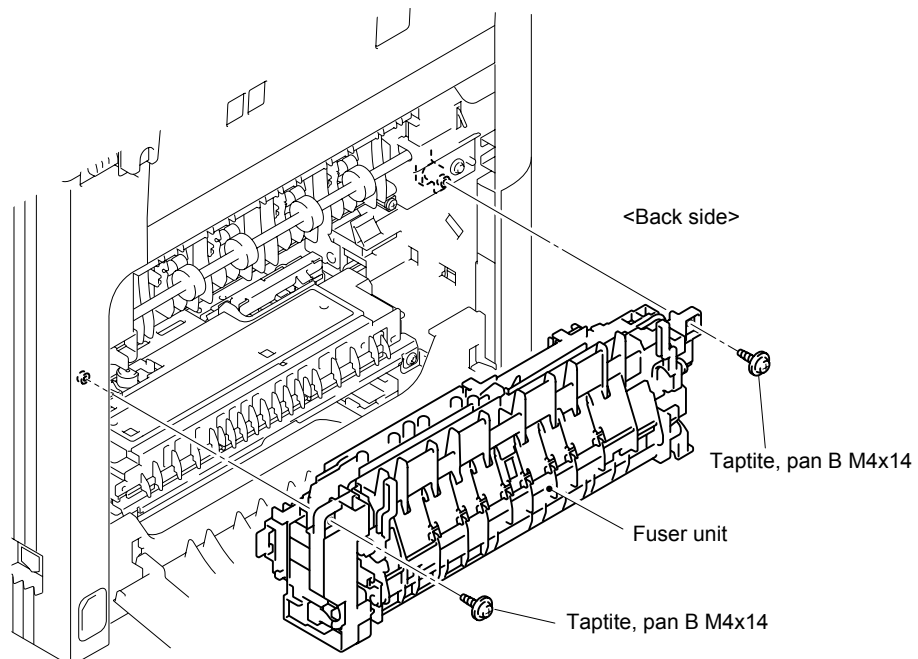

Fig. 2-2

- (3) Remove the Toner filter frame ASSY from the Paper eject ASSY DX/SX.

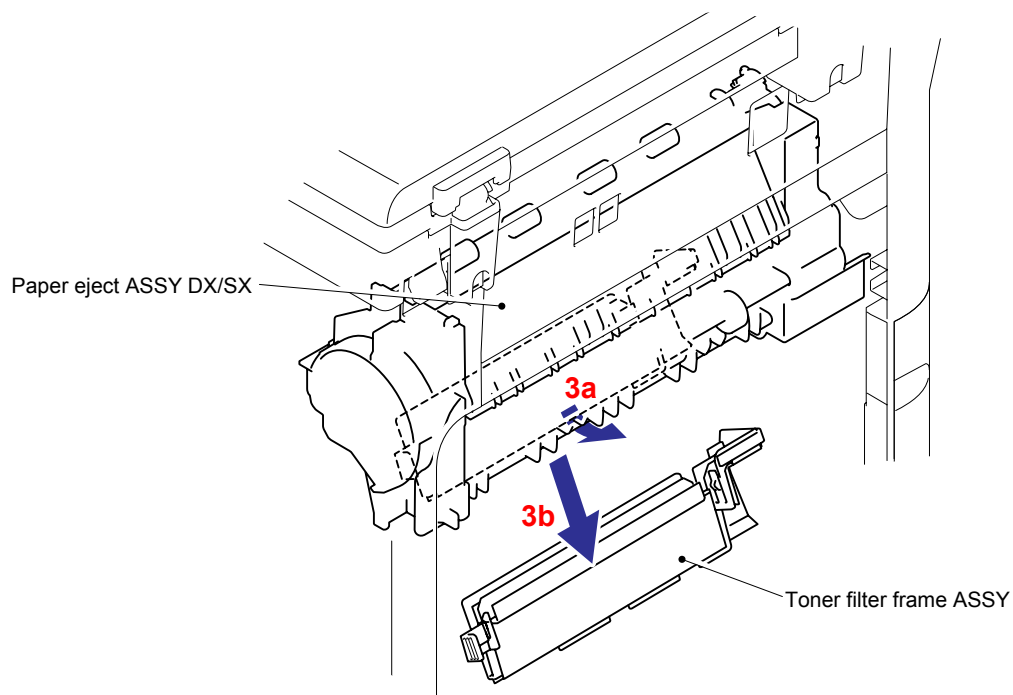

Fig. 2-3

<Installing Procedure>

- (1) Assemble the Toner filter frame ASSY onto the Paper eject ASSY DX/SX.

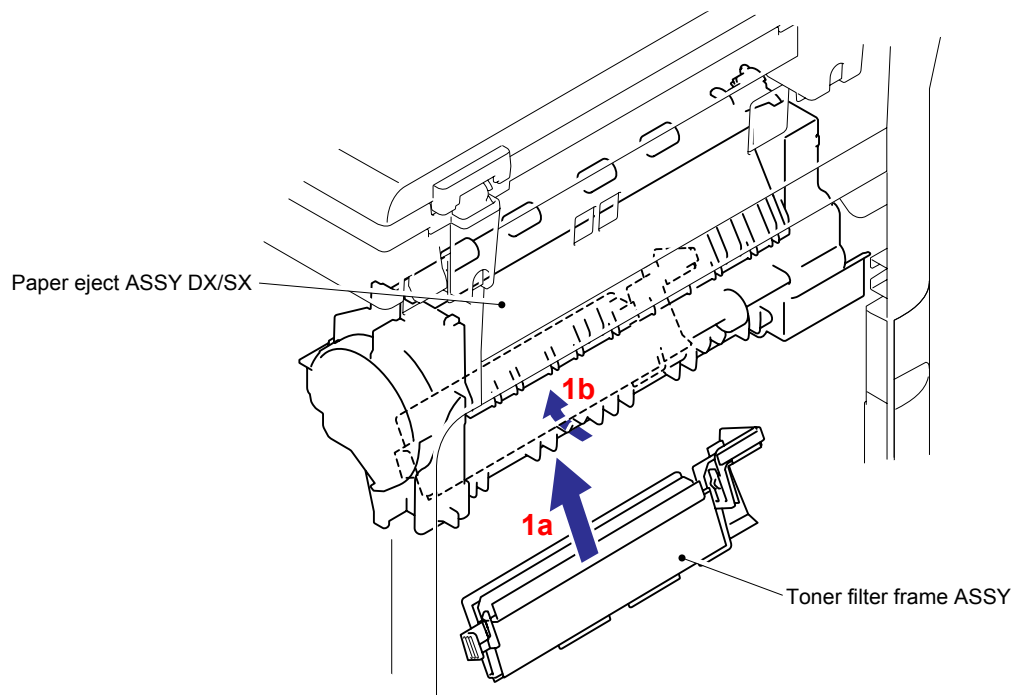

Fig. 2-4

- (2) Put the Fuser unit into the machine and fix it with the two pan B M4x14 Taptite screws.

***1 Tightening Note:**

When tightening the screw, slowly turn it counterclockwise (in the direction to loosen the screw) with your hand until you feel that the screw is a little dropped in the hole. Then, slightly turn it clockwise (in the direction to tighten the screw) with your hand and tighten it according to the specified torque with a screwdriver.

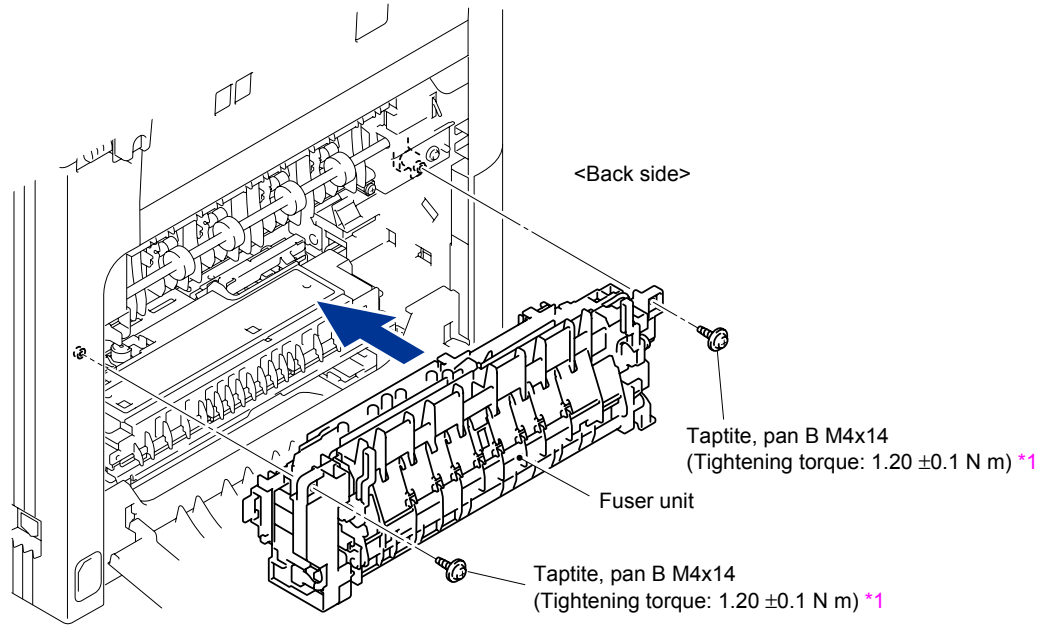

Fig. 2-5

Note:

- When assembling the fuser unit, make sure that the two Harnesses are placed in the groove and under the rib of the Plastic frame. If they are not, then correct them as shown in the figure below.

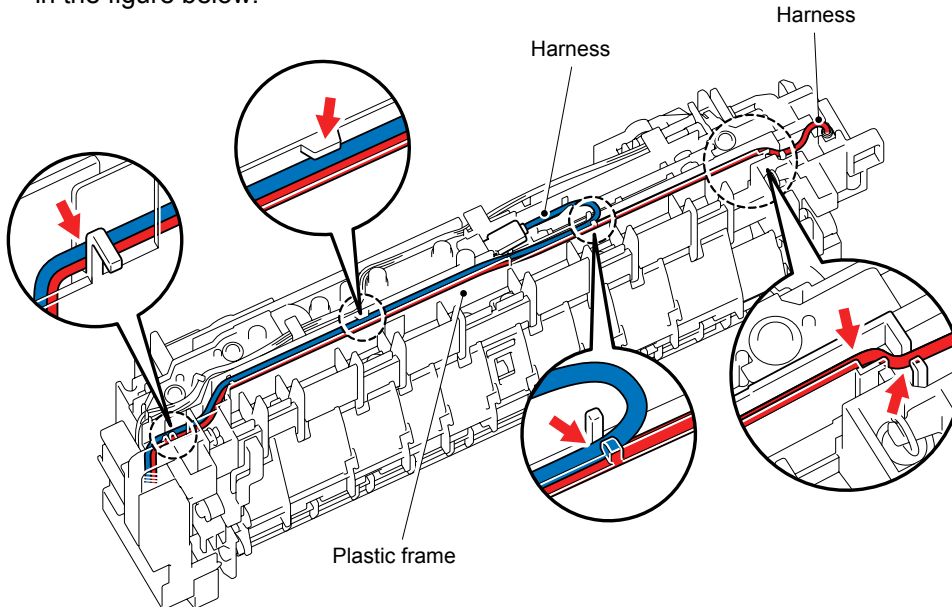

Fig. 2-6

- When assembling or disassembling the fuser unit, the sponge on the HV TR top cover might get scraped. If it is scraped, remove the scraped waste and clean the feeding path. After replacing the fuser unit, be sure to execute the test print and check that there are no print failures, such as vertical lines on the print result.

(3) Close the Back cover.

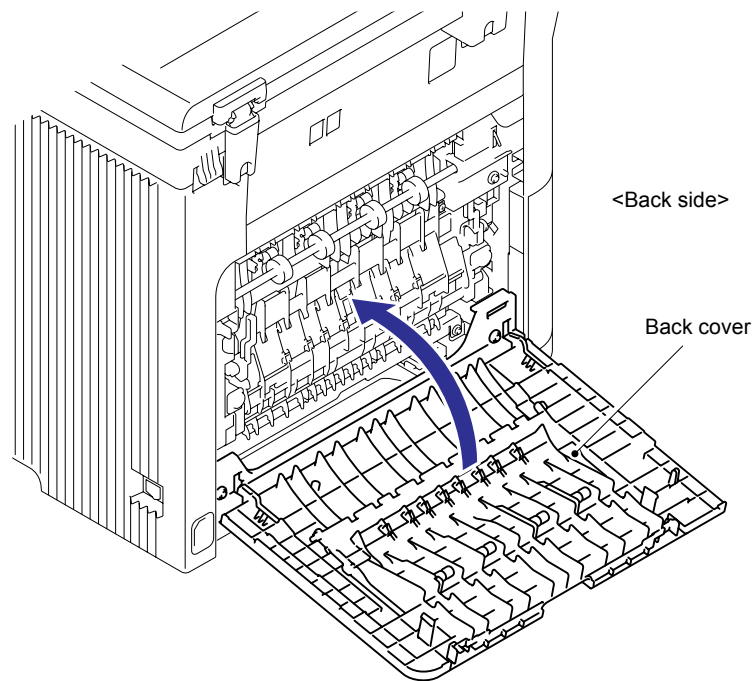

Fig. 2-7

(4) After replacing the Fuser unit, reset the counter. (Refer to [“2.3 Parts Life Reset Function”](#) in this chapter.)

2.2.2 Laser Unit

<Uninstalling Procedure>

(1) Press the Front cover release button, and open the Front door unit ASSY.

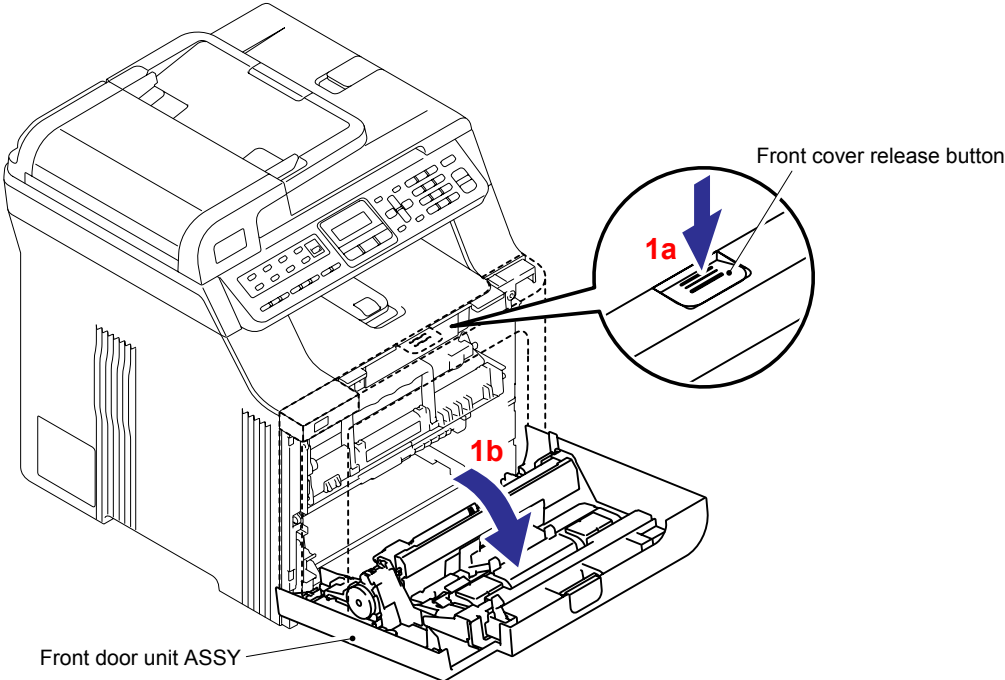

Fig. 2-8

(2) Open the Back cover.

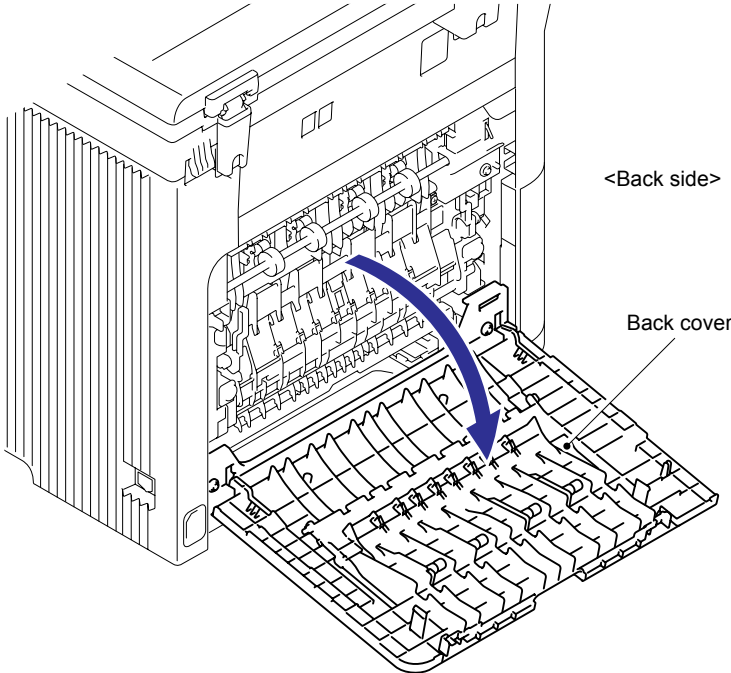

Fig. 2-9

- (3) Remove the two cup S M3x8 Taptite screws, and then remove the Back cover upper.

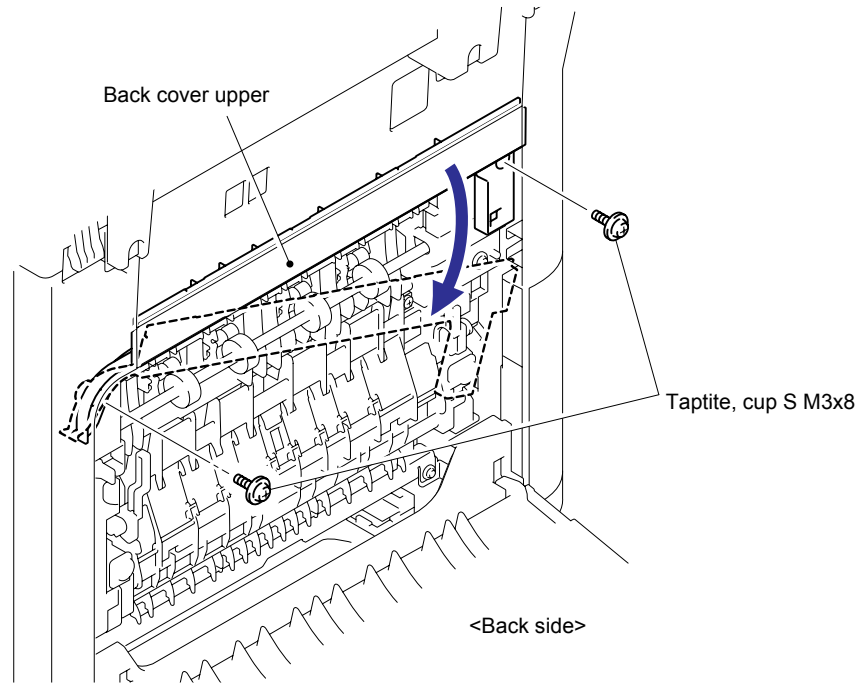

Fig. 2-10

- (4) Remove the two cup S M3x8 Taptite screws, and then remove the Back cover ASSY.

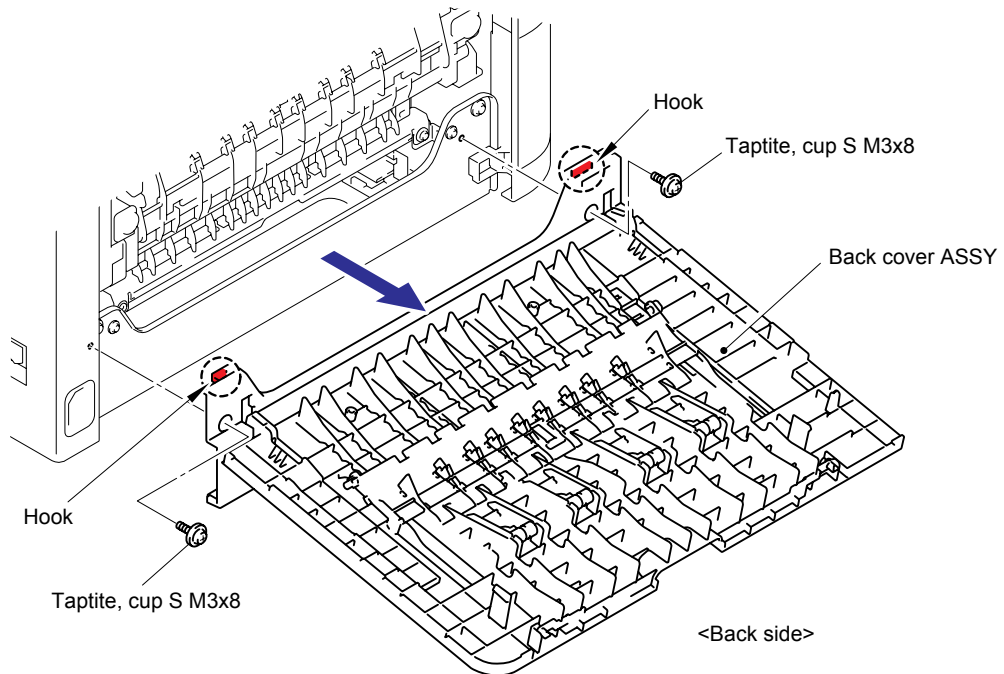

Fig. 2-11

- (5) Remove the cup S M3x8 Taptite screw and three cup B M4x12 Taptite screws.
- (6) Release the three Hooks on the bottom and the two hooks on the back side, and then remove the Side cover L ASSY.

Note:

When removing the Side cover L ASSY, pay attention to the Wire support rope.

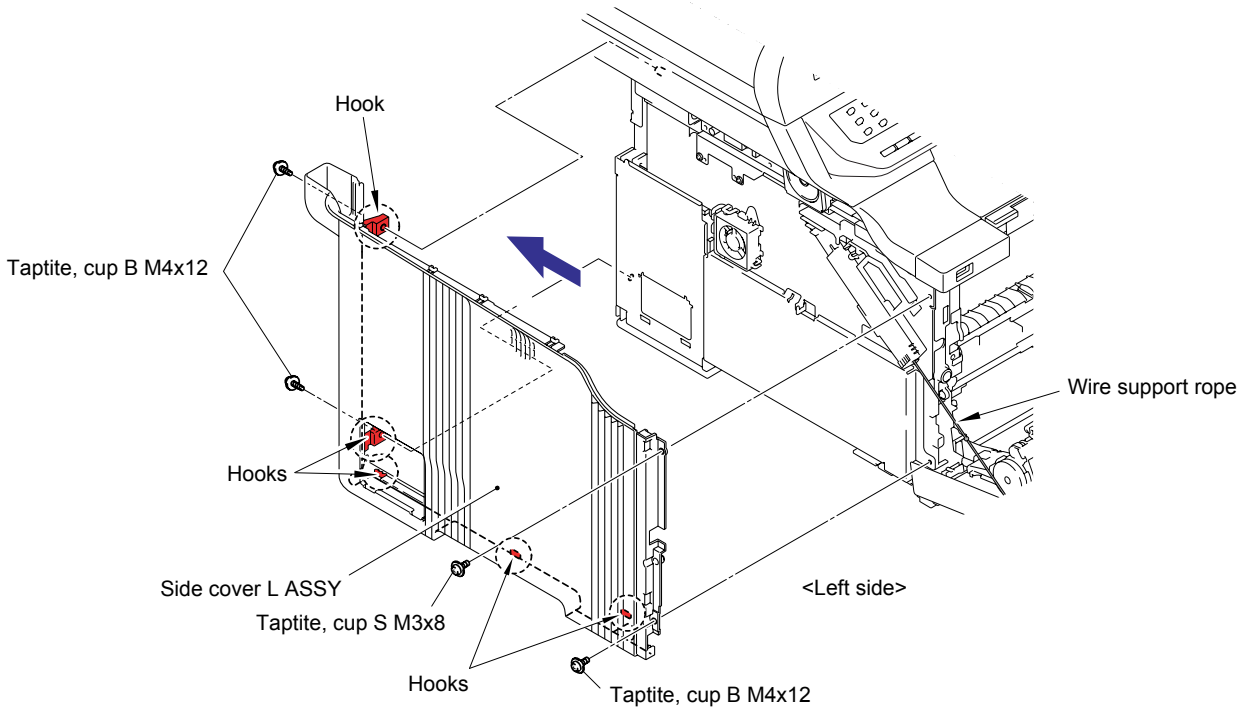

Fig. 2-12

- (7) Remove the three cup S M3x6 Taptite screws, one cup B M4x12 Taptite screw and one cup S M4x8 Taptite screw, and then remove the Side plate LB.

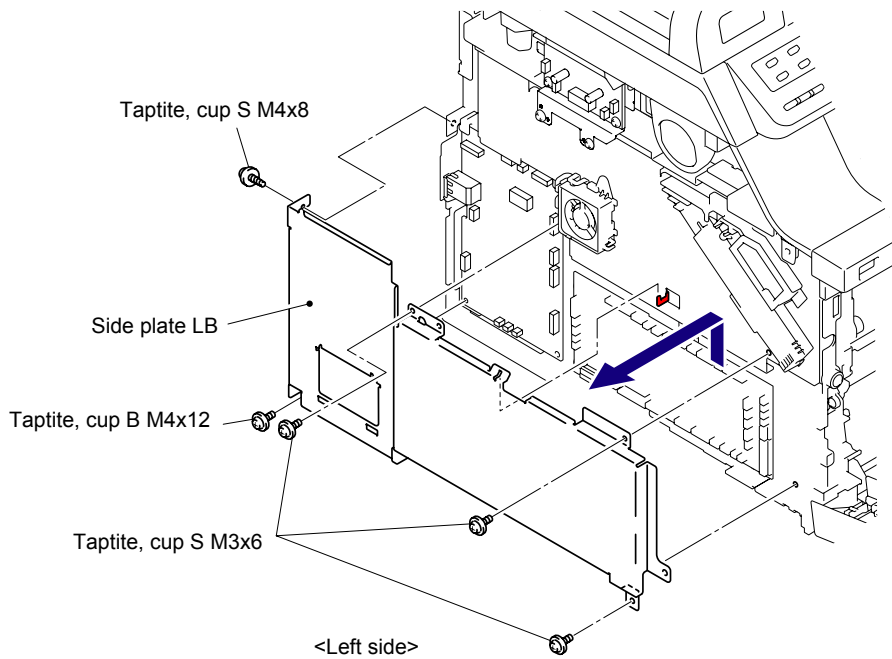

Fig. 2-13

- (8) Remove the two cup B M4x12 Taptite screws and two cup S M4x8 Taptite screws.
- (9) Release the one Hook on the front side, two Hooks on the bottom and the two Hooks on the back side, and then remove the Side cover R ASSY.

Note:
When removing the Side cover R ASSY, be careful not to damage section "A".

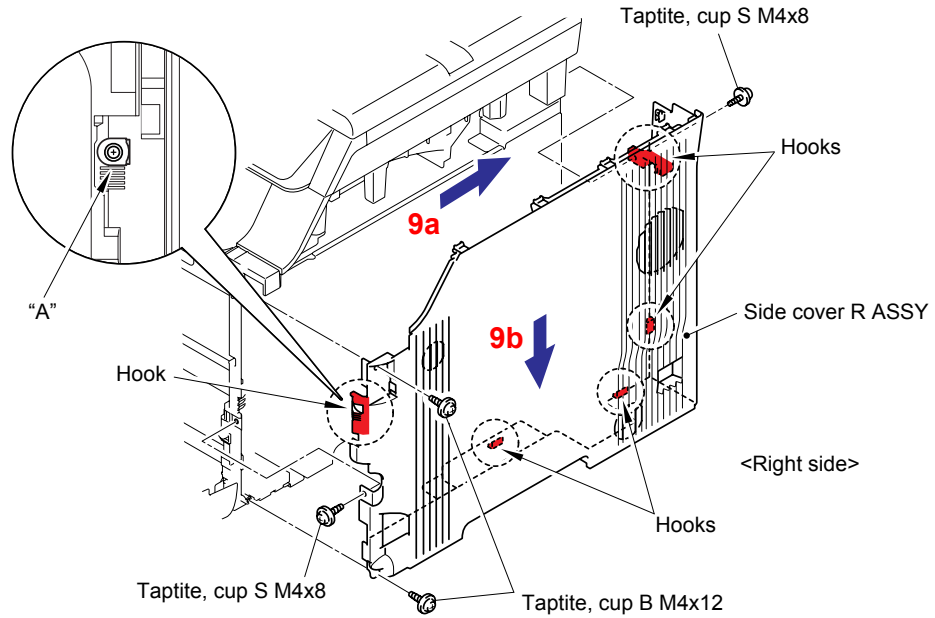

Fig. 2-14

- (10) Disconnect the three Connectors (CN1, CN2, CN5) from the Driver PCB ASSY.

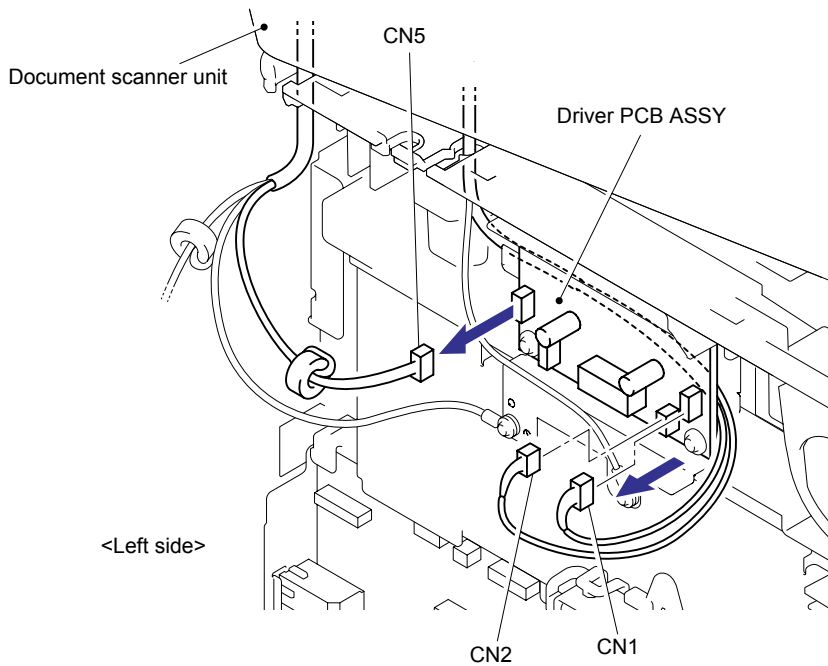

Fig. 2-15

- (11) Remove the cup S M3x6 Taptite screw, and then remove the FG harness ADF from the Driver PCB shield.
- (12) Remove the cup S M3x6 Taptite screw, and then remove the FG harness FB from the Driver PCB shield.

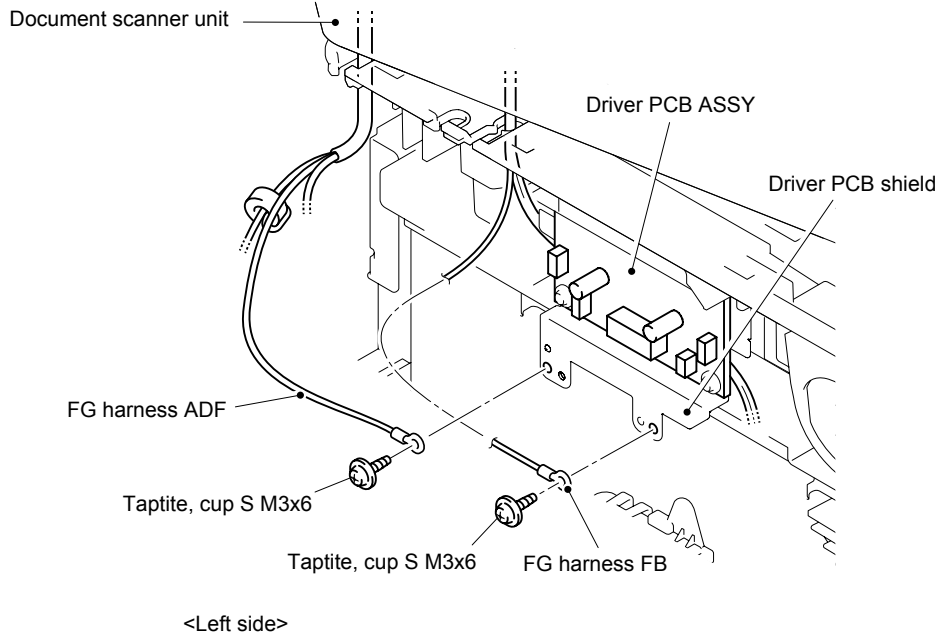

Fig. 2-16

- (13) Disconnect the two Connectors (CN14, CN21) and Flat cable (CN18) from the Main PCB ASSY.

Note:

After disconnecting the flat cable(s), check that each cable is not damaged at its end or short-circuited.

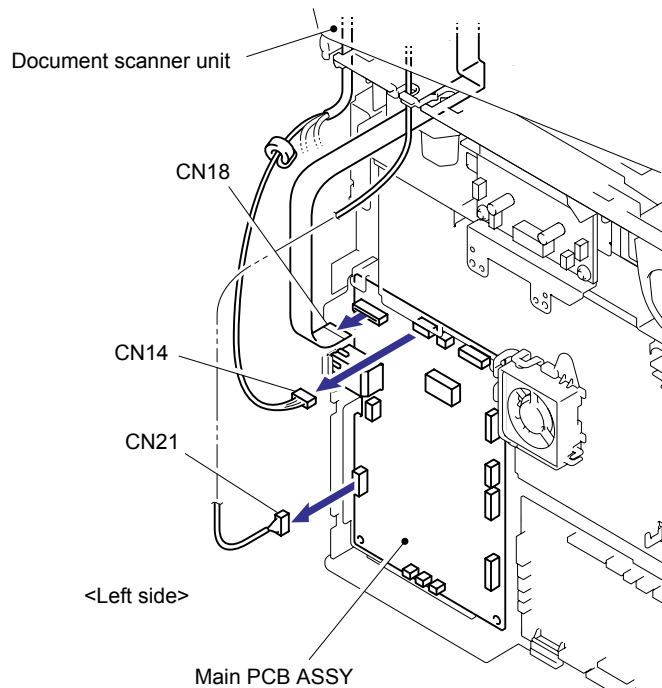

Fig. 2-17

- (14) Open the Document scanner unit, and then release the Hooks of the Pull arms L and R from the joint of the Document scanner unit.

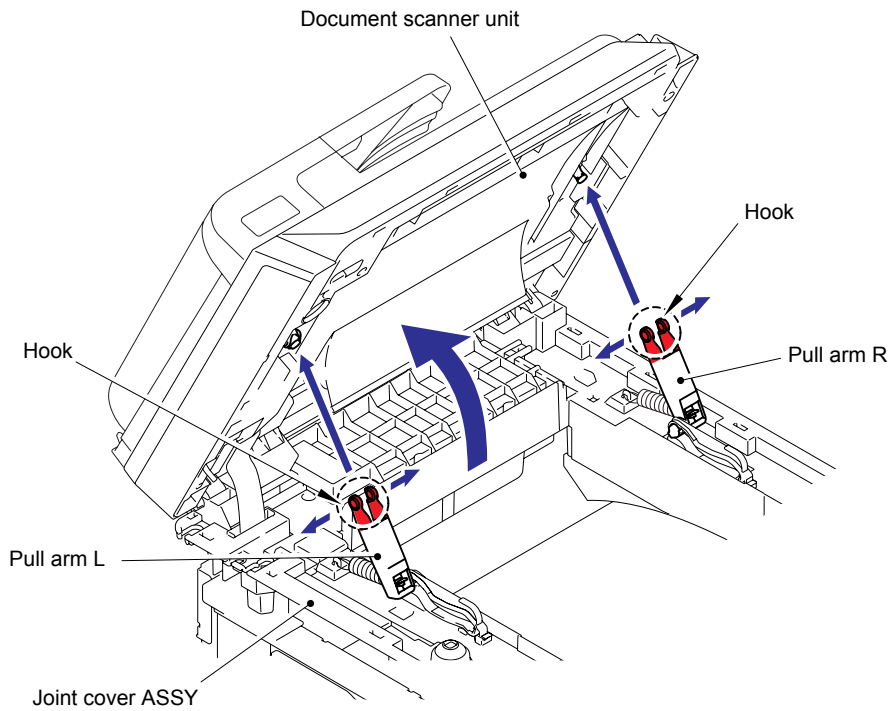

Fig. 2-18

- (15) Remove the Document scanner unit from the Joint cover ASSY.

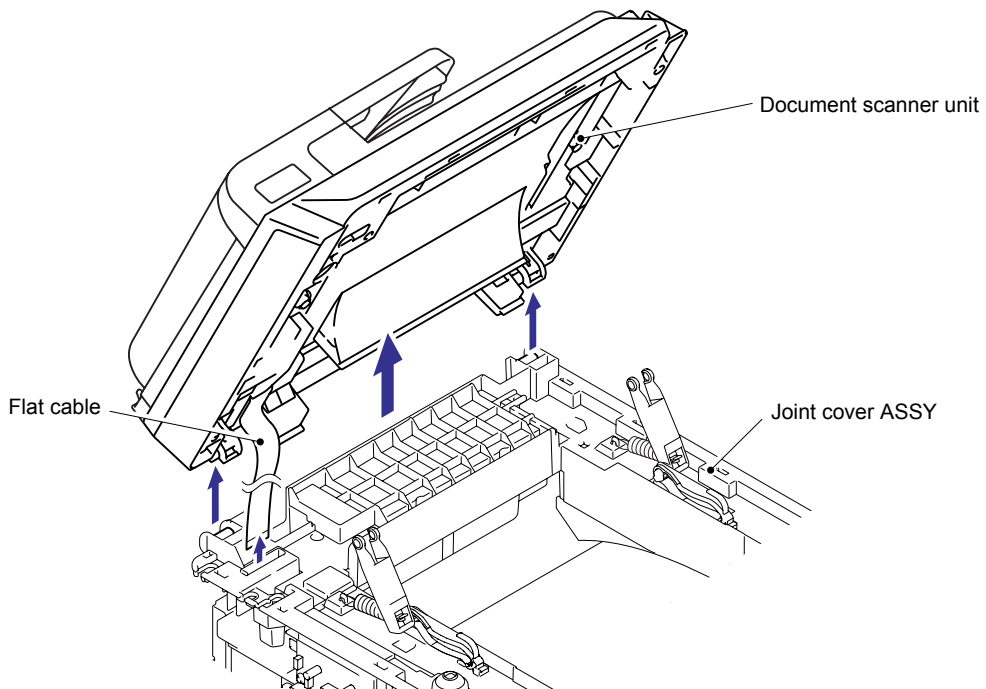

Fig. 2-19

- (16) Disconnect the four Connectors (CN3, CN7, CN10, CN19) from the Main PCB ASSY.
(CN3, CN7: MFC-9440CN/ 9450CDN only)

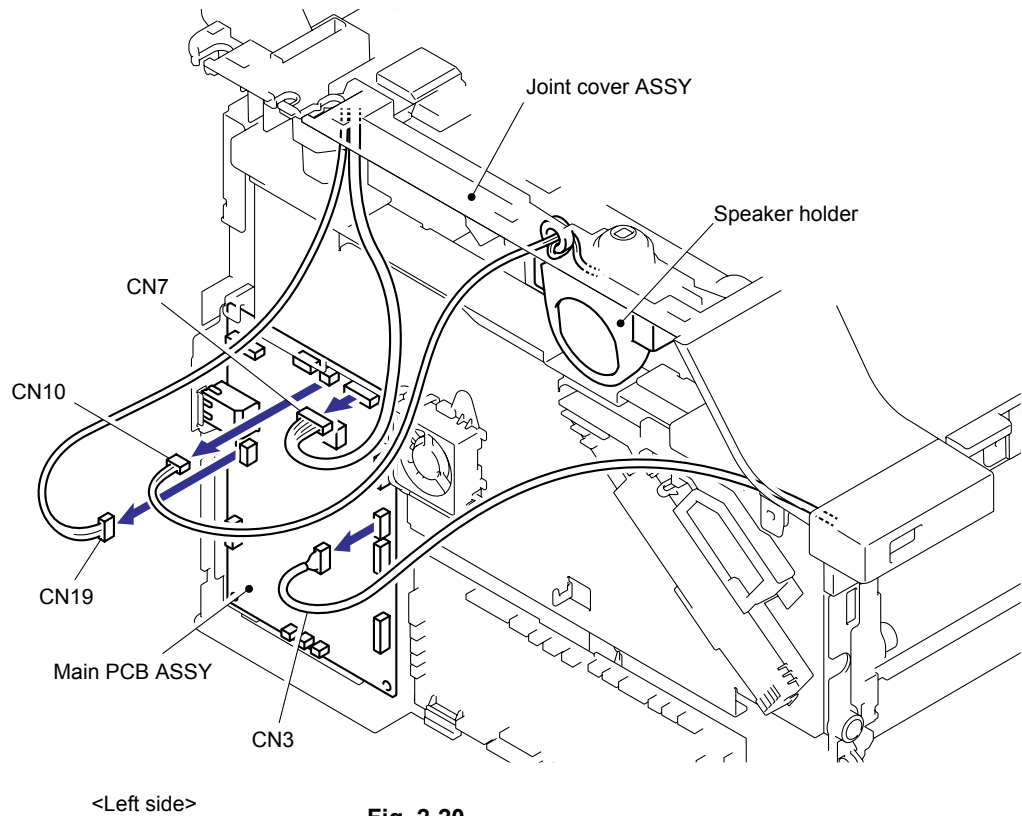

Fig. 2-20

- (17) Remove the cup S M3x8 Taptite screw from the Joint sub cover.
(18) Release the two Hooks to remove the Joint sub cover from the Joint cover ASSY.

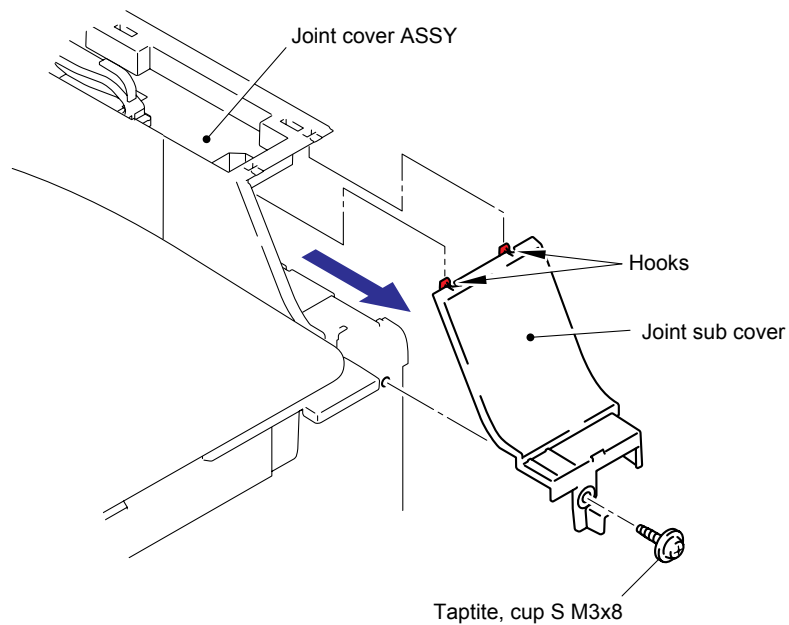

Fig. 2-21

- (19) Remove the three cup S M3x6 Taptite screws from the front side of the Joint cover ASSY, and remove two cup S M3x8 Taptite screws from the left side of the Joint cover ASSY.

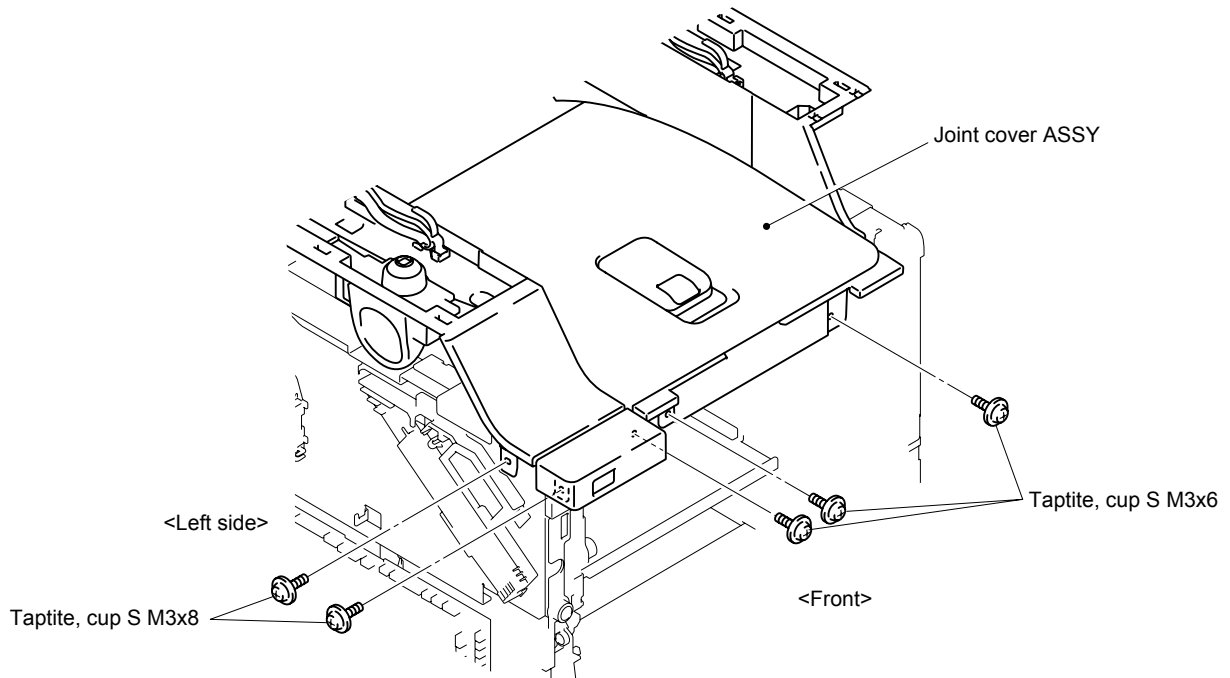

Fig. 2-22

- (20) Remove the three cup S M3x6 Taptite screws from the back side of the Joint cover ASSY.

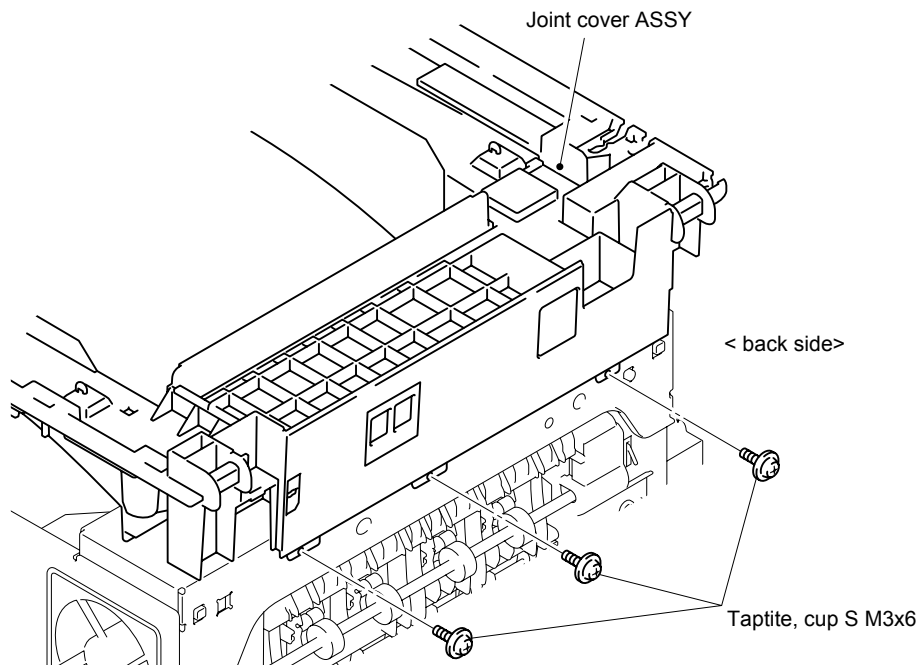

Fig. 2-23

(21) Remove the six cup S M4x8 Taptite screws from the top side of the Joint cover ASSY.

(22) Release the Pin to remove the Joint cover ASSY from the Frame unit.

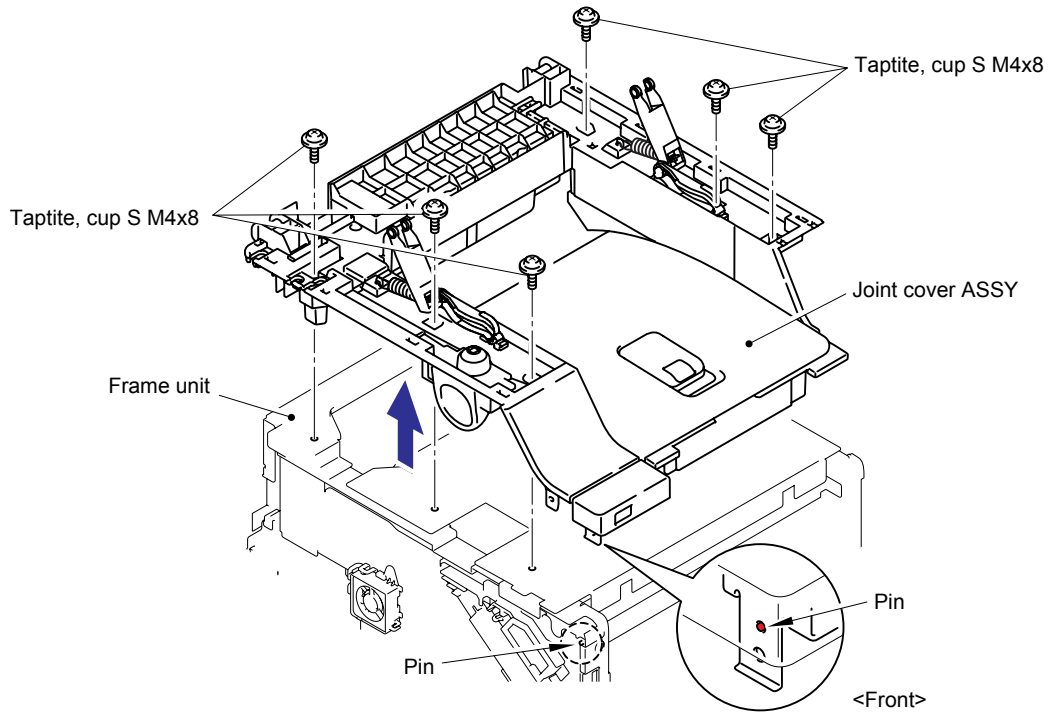

Fig. 2-24

(23) Remove the four cup S M3x8 Taptite screws, and then remove the two Hook slopes.

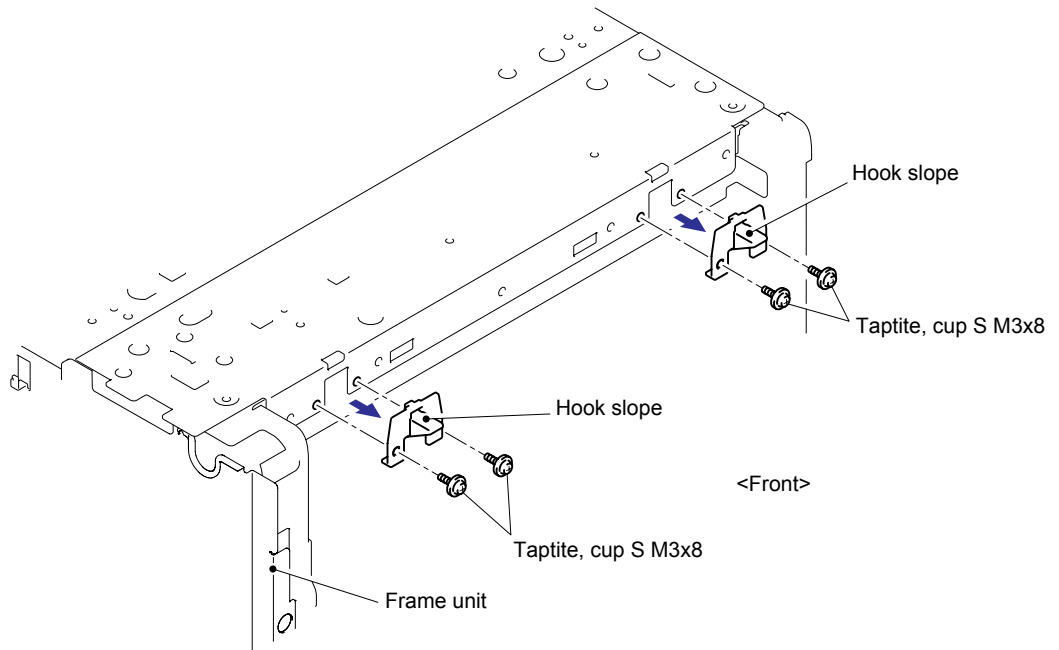

Fig. 2-25

(24) Remove the nine cup S M3x6 Taptite screws (8 pieces from the top and 1 piece from the front side), and then remove the Scanner cover.

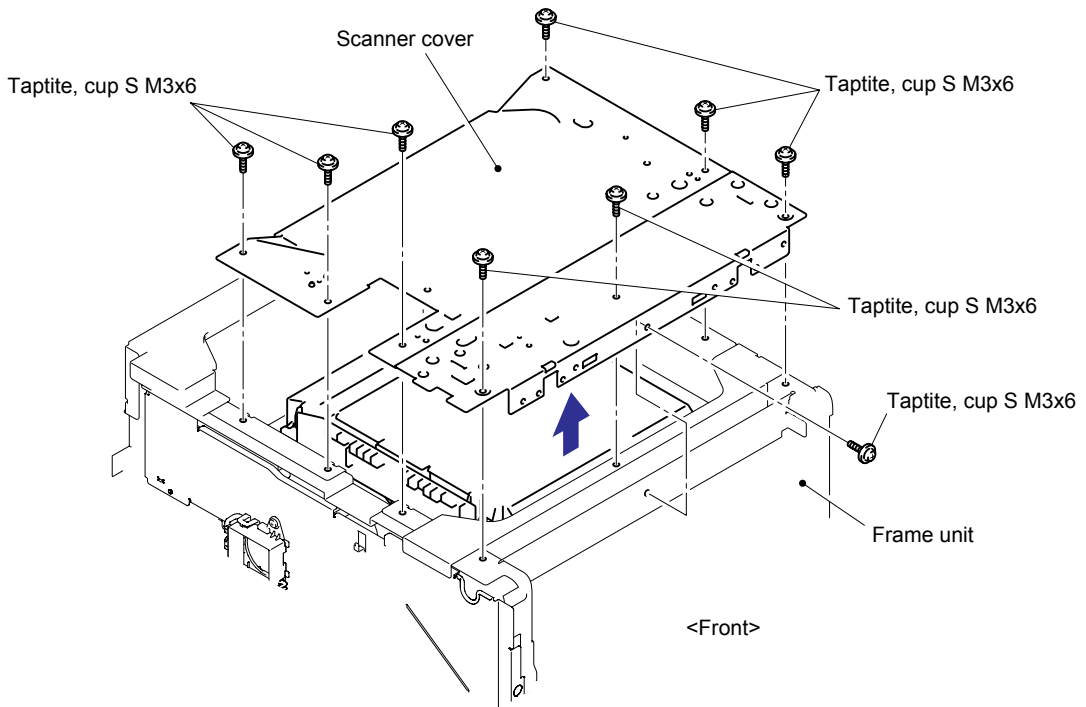

Fig. 2-26

(25) Disconnect the two flat cables (CN1, CN4) and connector (CN8) from the Laser unit.

Note:

After disconnecting the flat cable(s), check that each cable is not damaged at its end or short-circuited.

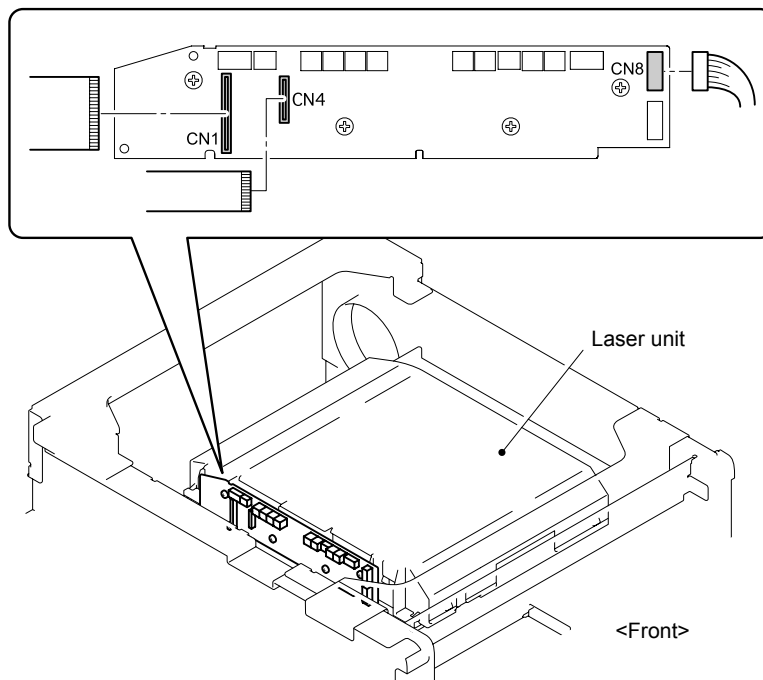

Fig. 2-27

- (26) Remove the seven cup S M3x6 SR Taptite screws, and then remove the four Scanner holders and Laser unit.

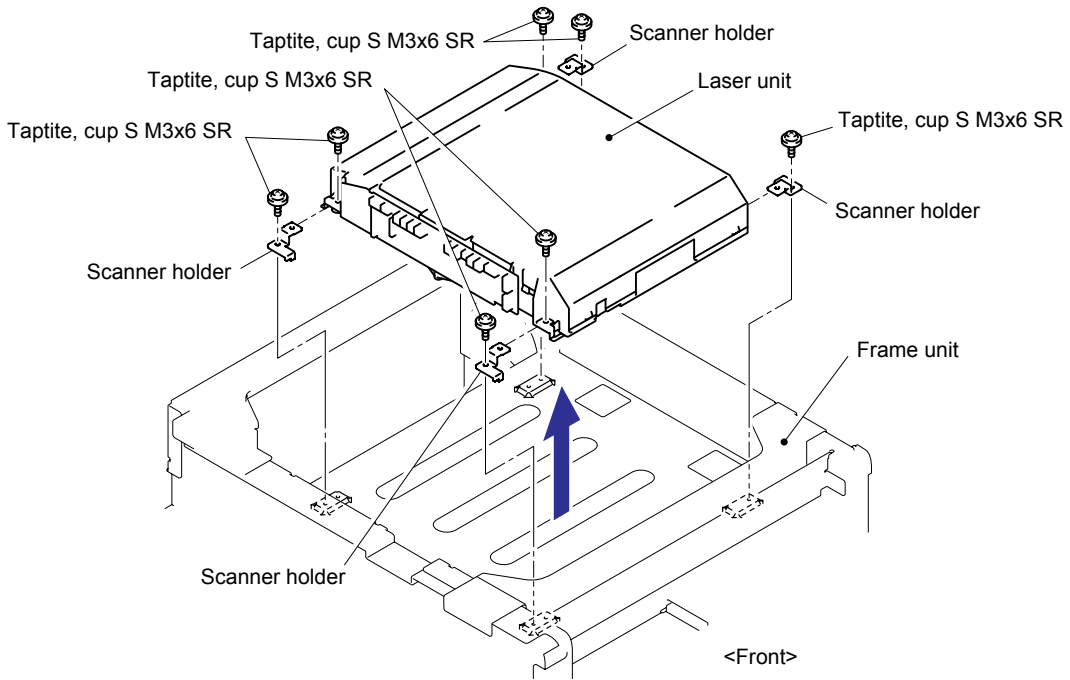

Fig. 2-28

<Installing Procedure>

- (1) Assemble the Laser unit with the four Scanner holders and seven cup S M3x6 SR Taptite screws.

Note:

When assembling the Laser unit with the Scanner holders, ensure to put the positioning boss of the Laser unit into the positioning hole referring to the figure below.

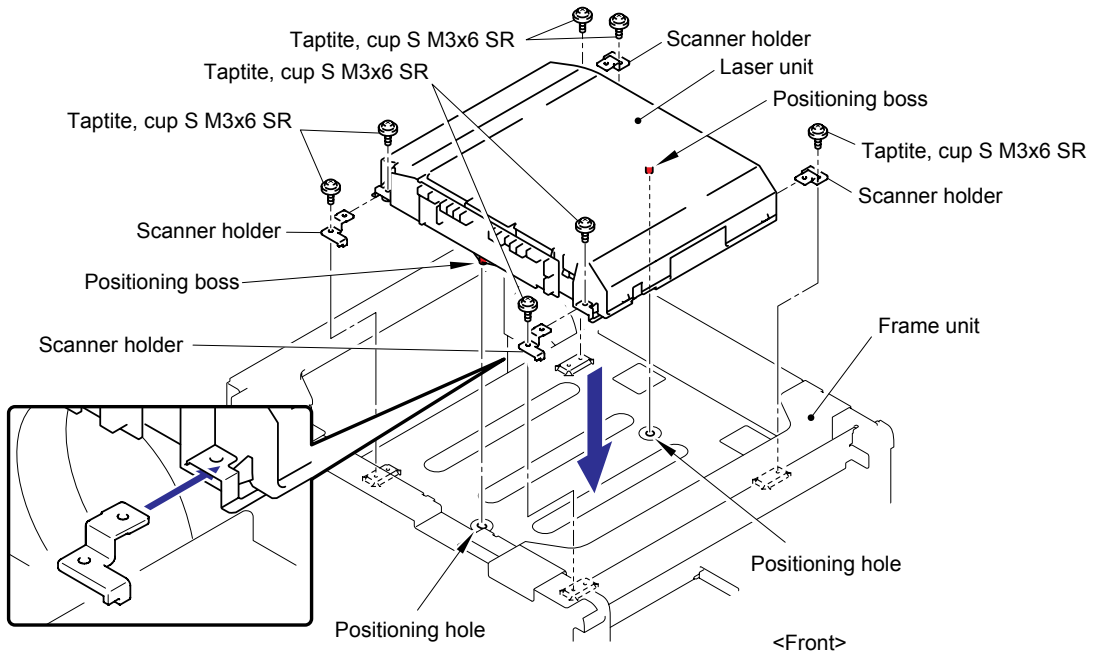

Fig. 2-29

- (2) Connect the two flat cables (CN1, CN4) and one connector (CN8) into the Laser unit.

Note:

When connecting the flat cable(s), do not insert it at an angle. After insertion, check that the cable is not at an angle.

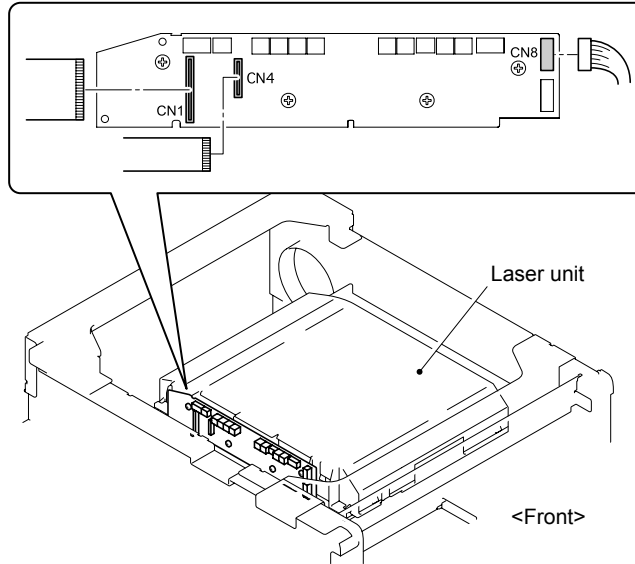

Fig. 2-30

- (3) Assemble the Scanner cover with the nine cup S M3x6 Taptite screws (8 pieces on the top and 1 piece on the front side).

Note:

When assembling the Scanner cover, secure the Screws in the order of the numbers which are indicated on the Scanner cover.

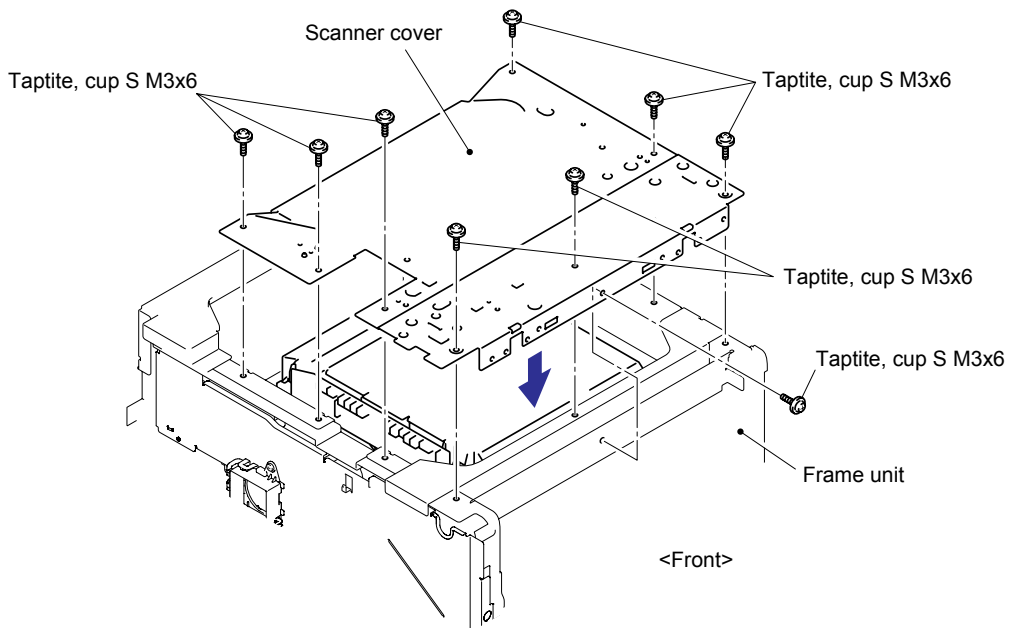

Fig. 2-31

- (4) Assemble the two Hook slopes with the four cup S M3x8 Taptite screws.

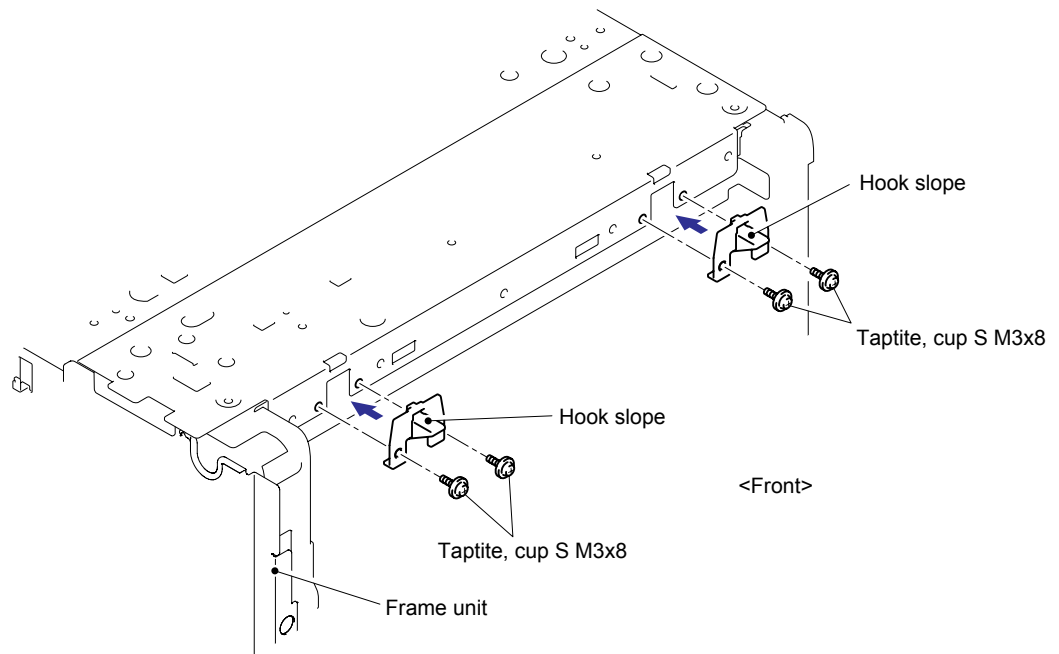

Fig. 2-32

- (5) Catch the Pin. Then, put the Joint cover ASSY onto the Frame unit and secure the six cup S M4x8 Taptite screws onto the top of the cover.

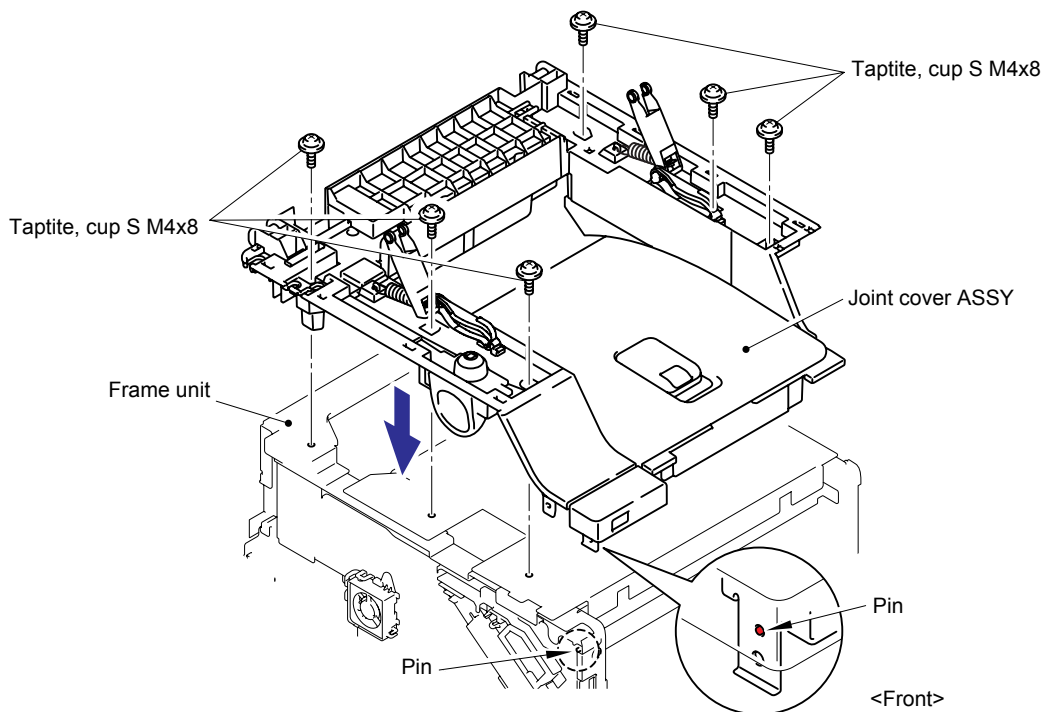

Fig. 2-33

- (6) Secure the three cup S M3x6 Taptite screws onto the back side of the Joint cover ASSY.

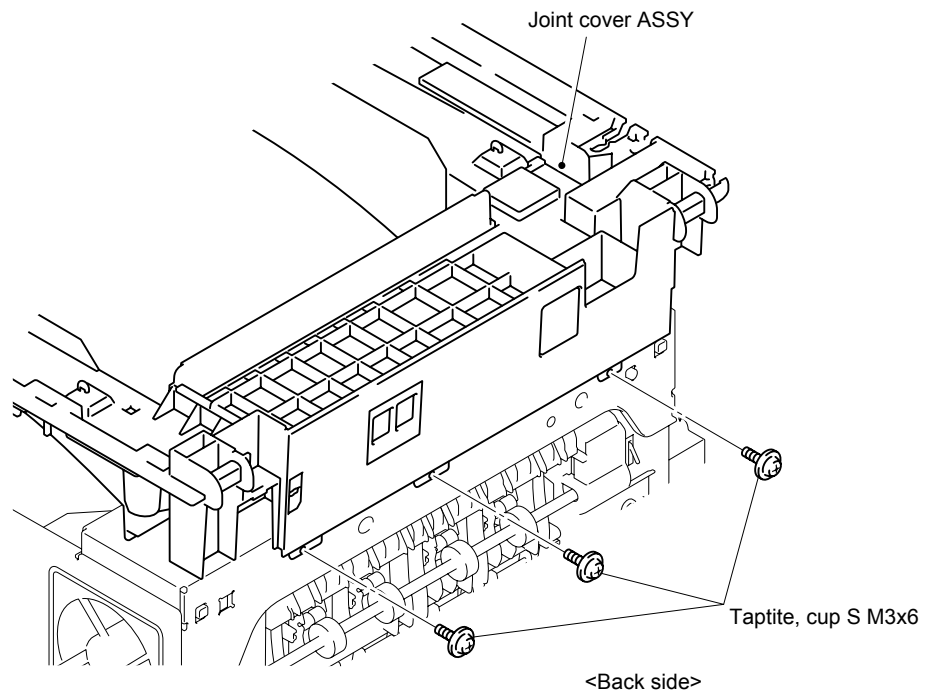

Fig. 2-34

- (7) Secure the three cup S M3x6 Taptite screws onto the front side of the Joint cover ASSY.
(8) Secure the two cup S M3x8 Taptite screws onto the left side of the Joint cover ASSY.

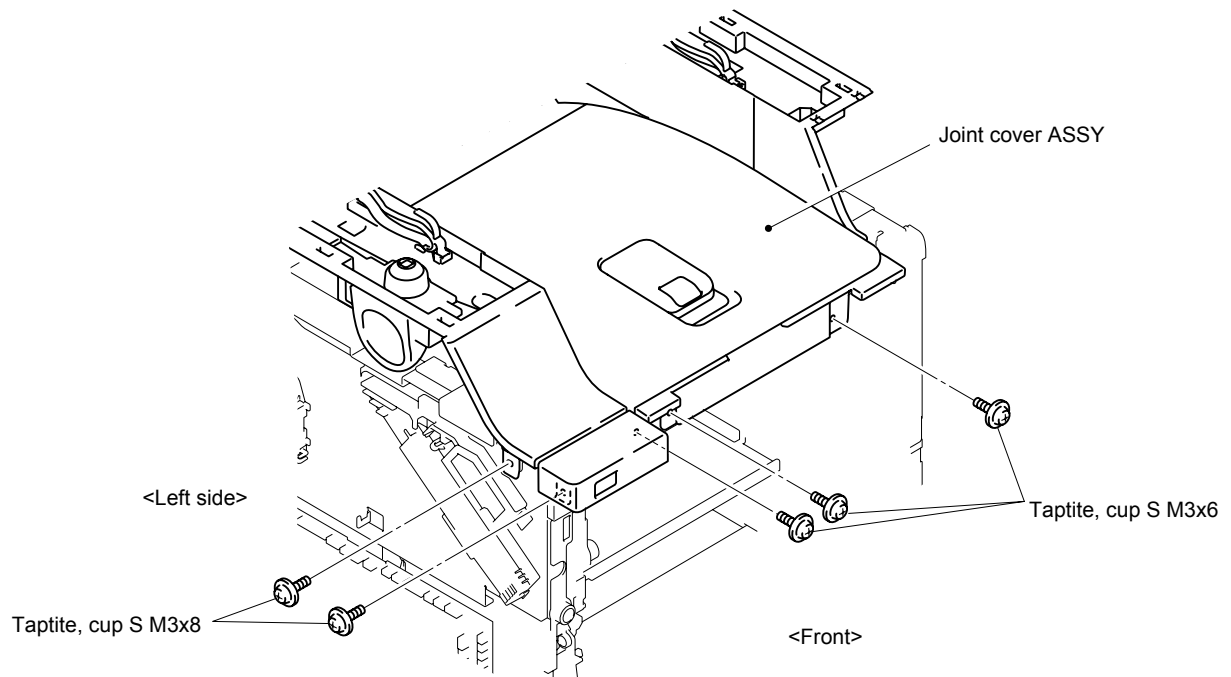

Fig. 2-35

- (9) Catch the Hooks of the Joint sub cover with the Joint cover ASSY and fix the Joint sub cover with the one cup S M3x8 Taptite screw.

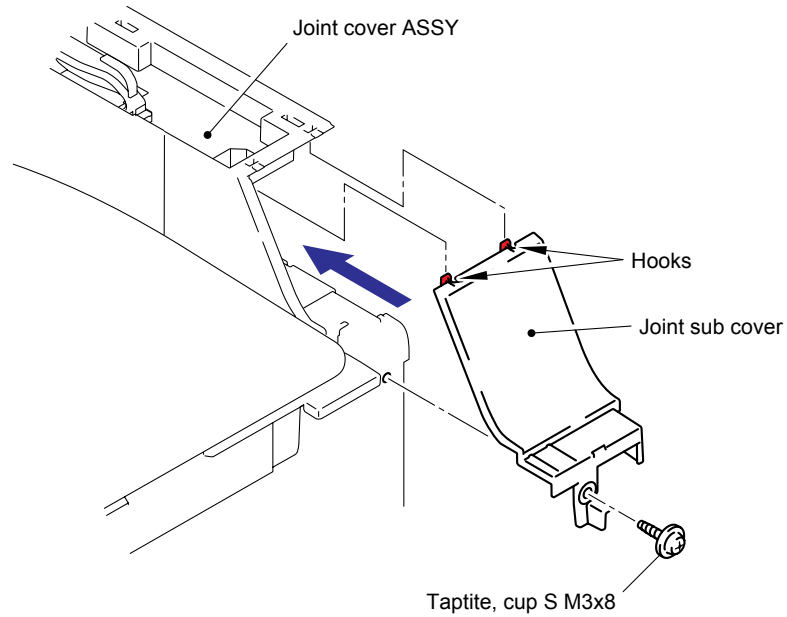

Fig. 2-36

- (10) Connect the four Connectors (CN3, CN7, CN10, CN19) into the Main PCB ASSY.
(CN3, CN7: MFC-9440CN/ 9450CDN only)

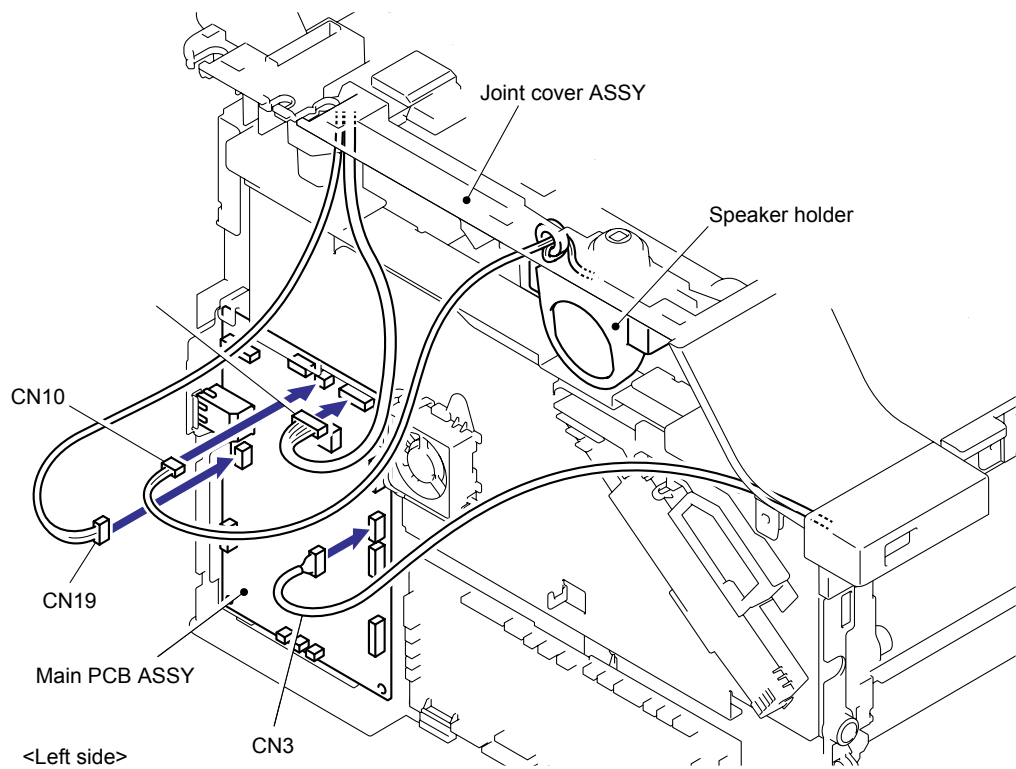

Fig. 2-37

- (11) Catch the two Hooks of the Document scanner unit with the Joint cover ASSY while putting the Flat cable of the Document scanner unit into the hole on the Joint cover ASSY.

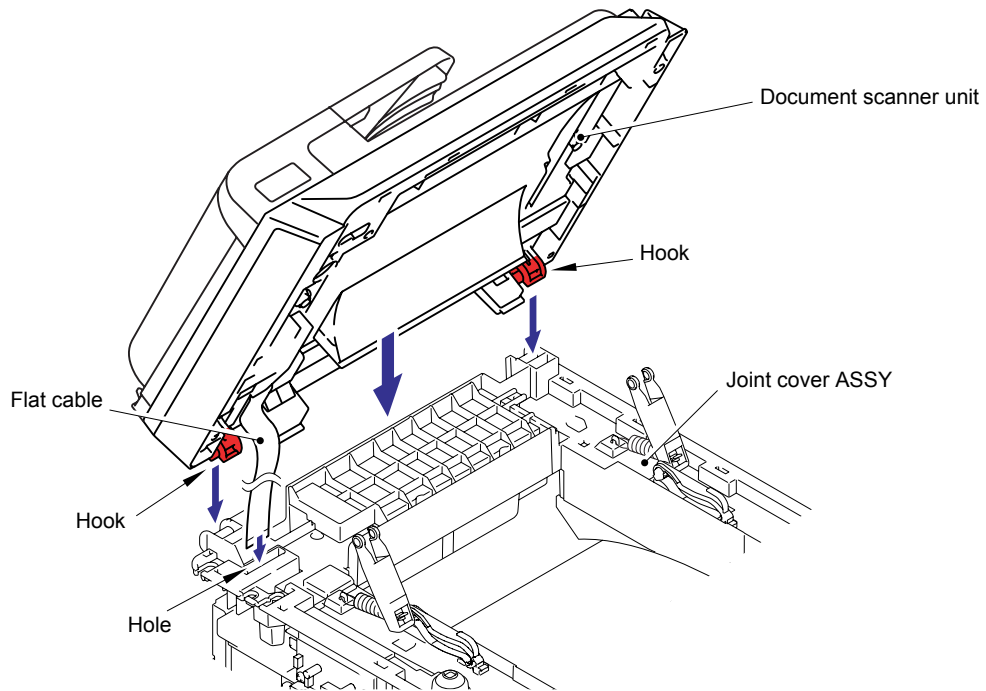

Fig. 2-38

- (12) Catch the Hooks of the Document scanner unit with Joint of the Pull arm L, R.

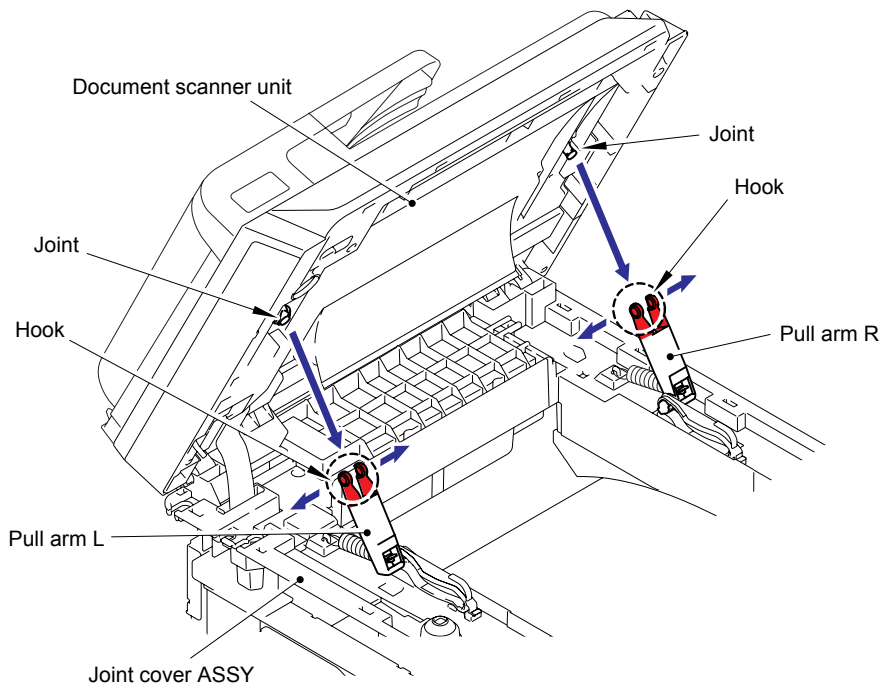

Fig. 2-39

- (13) Assemble the FG harness FB with the one cup S M3x6 Taptite screw.
- (14) Assemble the FG harness ADF with the one cup S M3x6 Taptite screw.

Note:

Make sure to place the Harness of the connector CN1 and CN2 on the back of the Driver PCB shield.

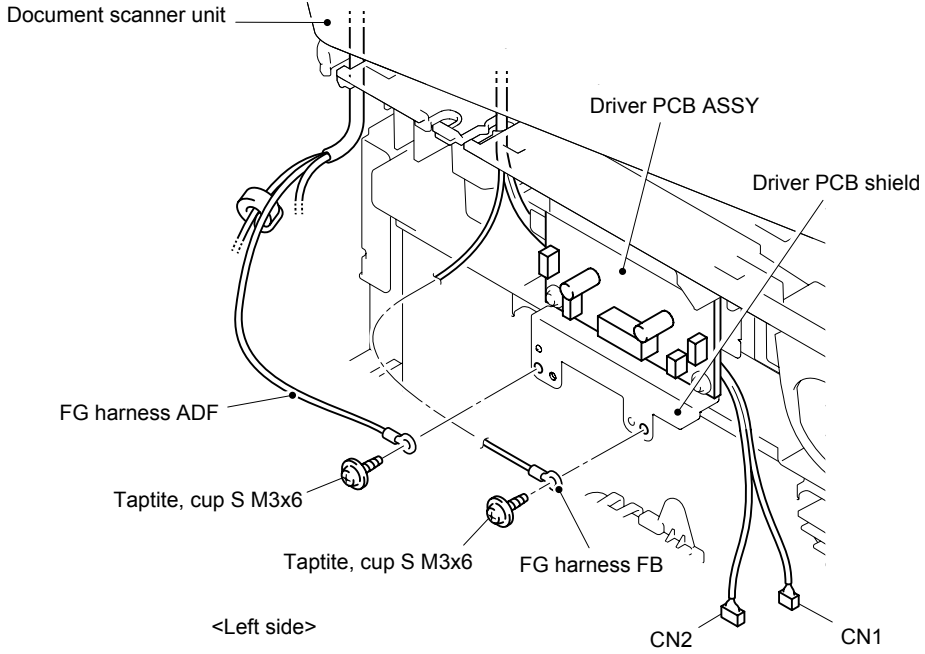

Fig. 2-40

- (15) Connect the three Connectors (CN1, CN2, CN5) into the Driver PCB ASSY.

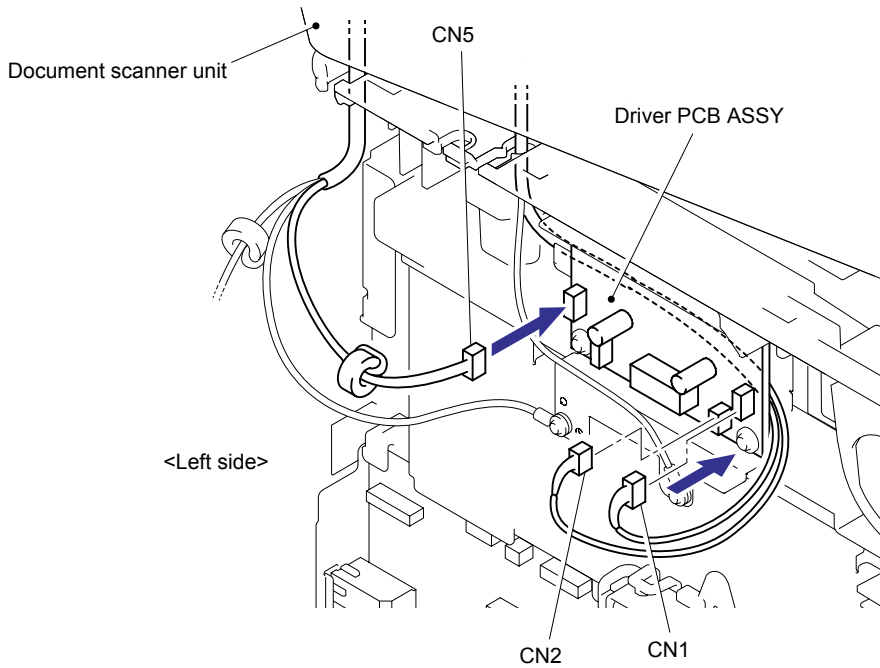

Fig. 2-41

(16) Connect the two Connectors (CN14, CN21) and Flat cable (CN18) into the Main PCB ASSY.

Note:

When connecting the Flat cable(s), do not insert it at an angle. After insertion, check that the cable is not at an angle.

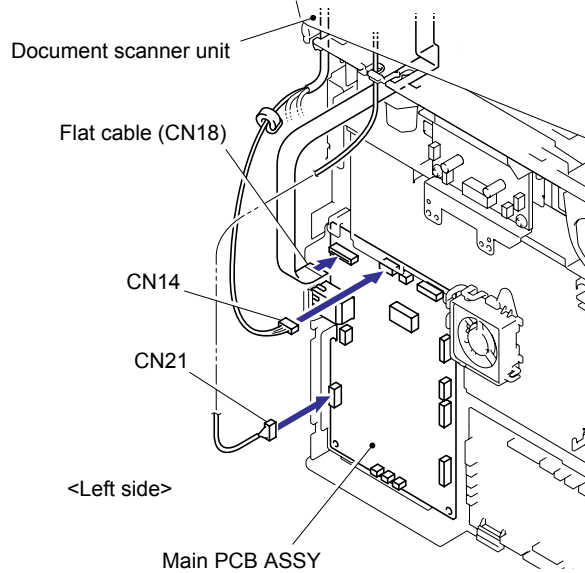

Fig. 2-42

(17) Catch the Hooks of the Side cover R ASSY with the main body in the order of 17a to 17e and fix the Side cover R ASSY with the two cup B M4x12 Taptite screws and two cup S M4x8 Taptite screws.

***1 Tightening Note:**

When tightening the screw, slowly turn it counterclockwise (in the direction to loosen the screw) with your hand until you feel that the screw is a little dropped in the hole. Then, slightly turn it clockwise (in the direction to tighten the screw) with your hand and tighten it according to the specified torque with a screwdriver.

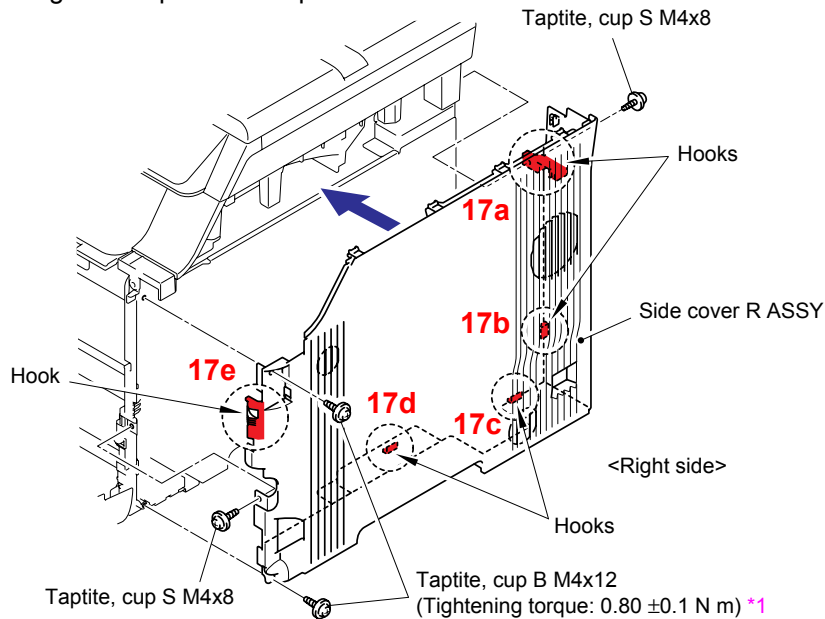

Fig. 2-43

- (18) Assemble the Side plate LB with the three cup S M3x6 Taptite screws, one cup B M4x12 Taptite screw and one cup S M4x8 Taptite screw.

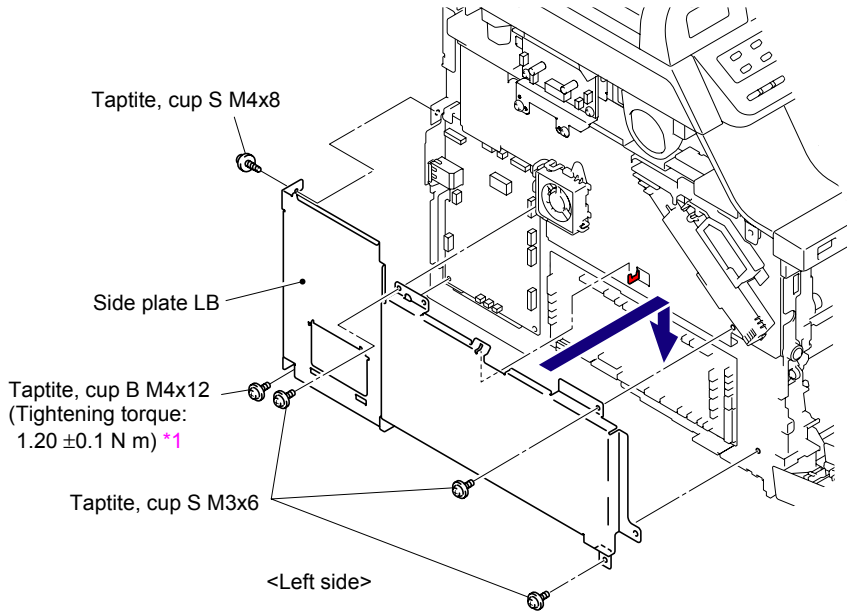

Fig. 2-44

- (19) Catch the Hooks of the Side cover L ASSY with the main body and fix the Side cover L ASSY with the one cup S M3x8 Taptite screw and three cup B M4x12 Taptite screws.

Note:

When assembling the Side cover L ASSY, pay attention to the Wire support rope.

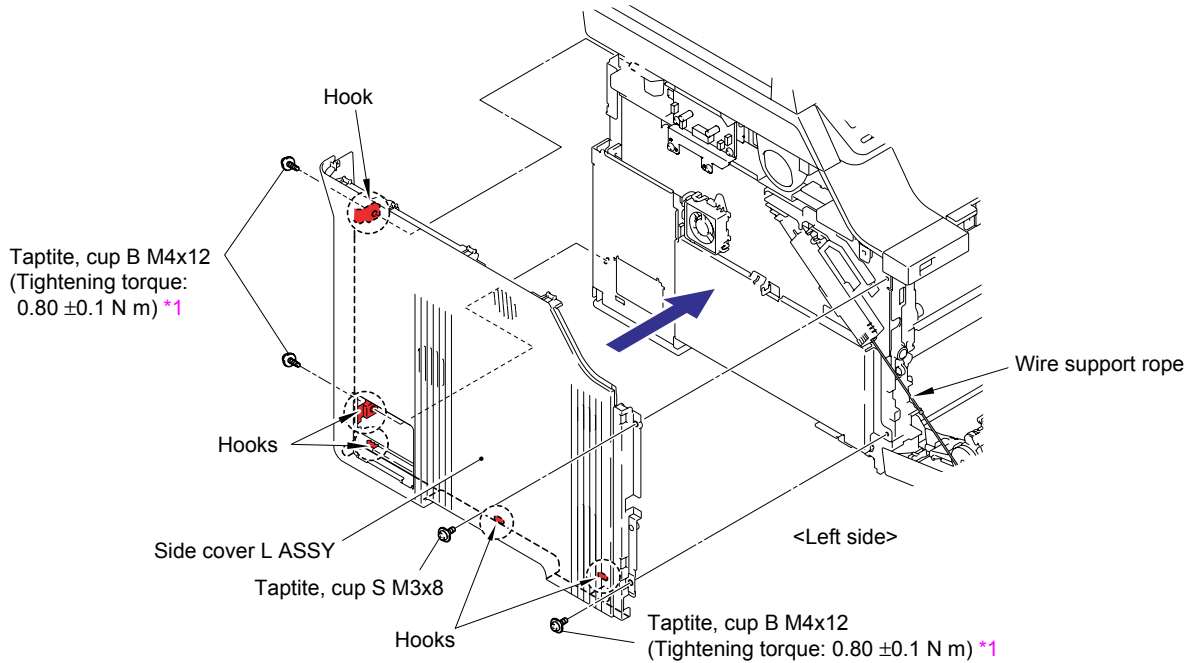

Fig. 2-45

***1 Tightening Note:**

When tightening the screw, slowly turn it counterclockwise (in the direction to loosen the screw) with your hand until you feel that the screw is a little dropped in the hole. Then, slightly turn it clockwise (in the direction to tighten the screw) with your hand and tighten it according to the specified torque with a screwdriver.

(20) Catch the Hooks of the Back cover ASSY and assemble it with the two cup S M3x8 Taptite screws.

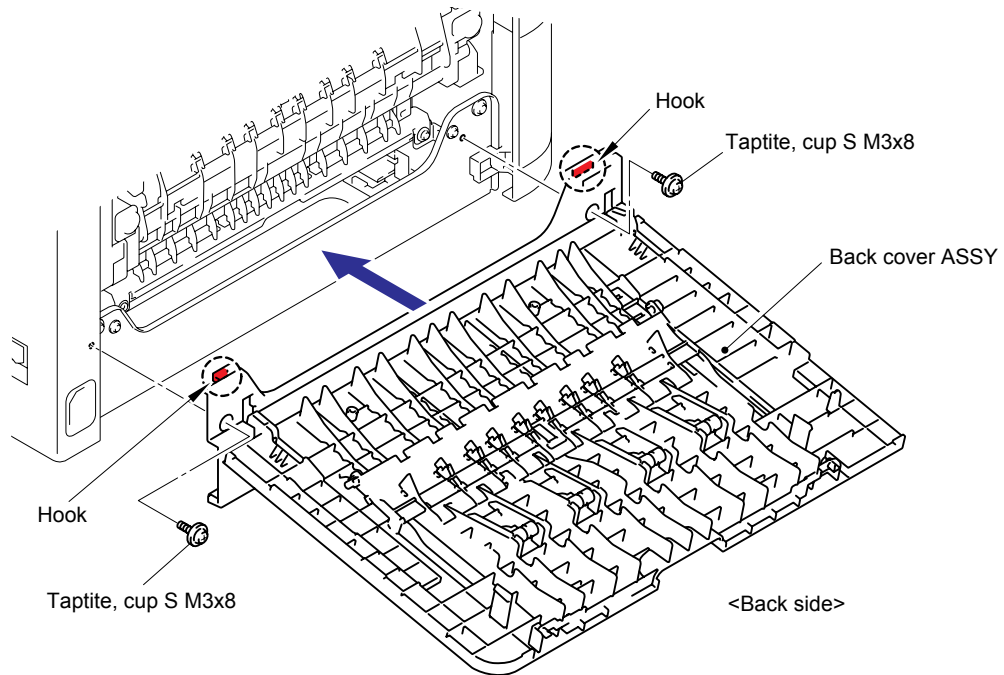

Fig. 2-46

(21) Assemble the Back cover upper with the two cup S M3x8 Taptite screws.

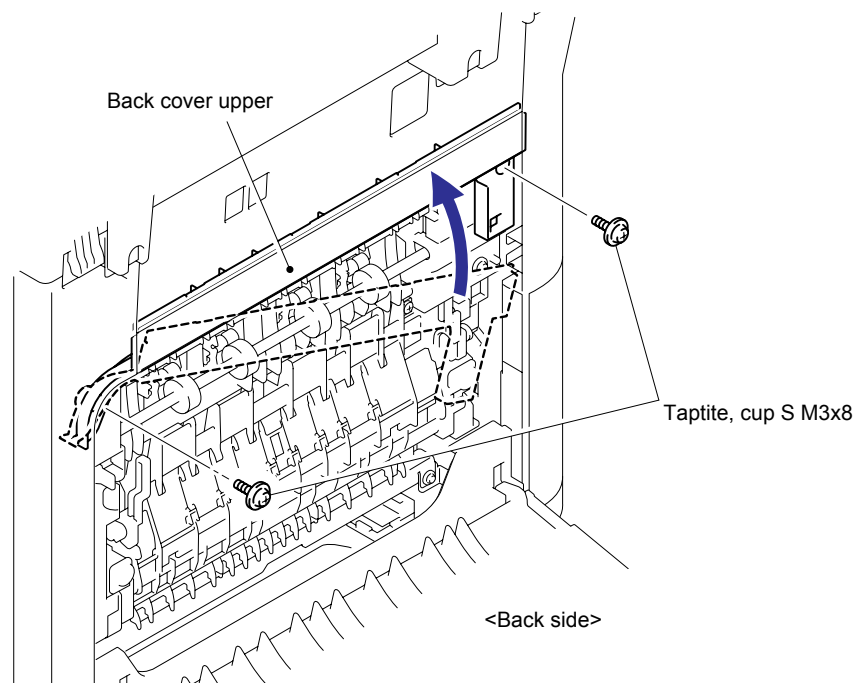

Fig. 2-47

(22) Close the Back cover.

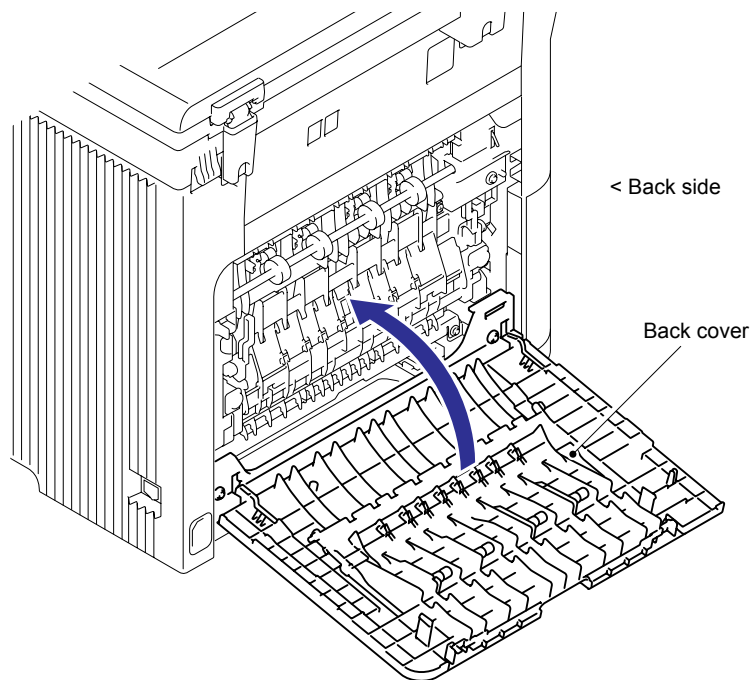

Fig. 2-48

(23) Close the Front door unit ASSY.

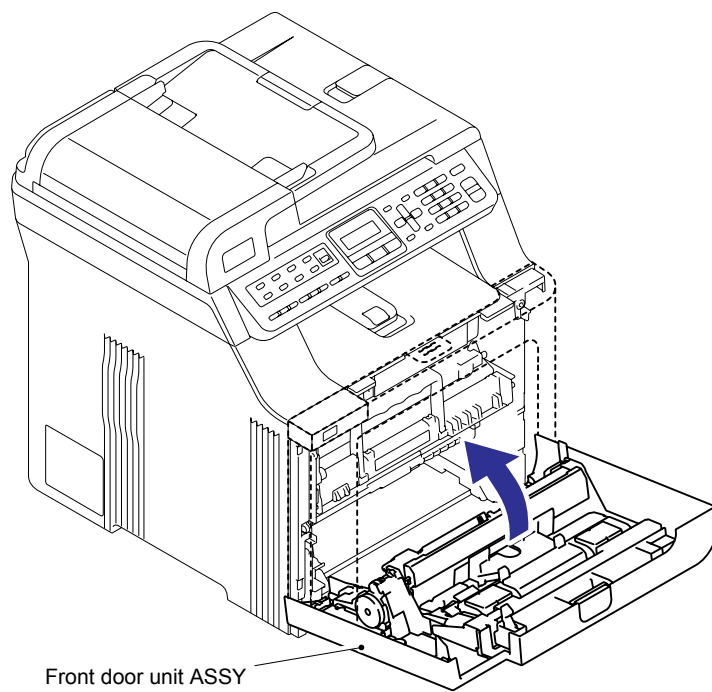

Fig. 2-49

(24) After replacing the Laser unit, reset the counter. (Refer to ["2.3 Parts Life Reset Function"](#) in this chapter.)

2.2.3 Paper Feeding Kit (PF Kit1, PF Kit2)

<Uninstalling Procedure>

- (1) Pull out the Paper tray, and remove the paper from the Paper tray.

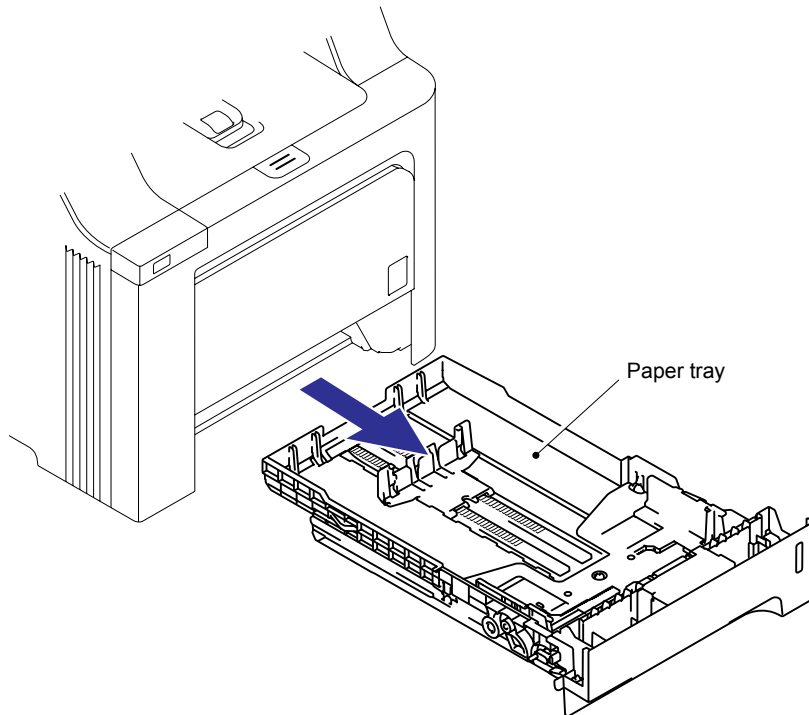

Fig. 2-50

- (2) Release the two Hooks of the Separation pad ASSY, and then lift up the Separation pad ASSY.

Note:

Be careful not to loose the Separation pad spring.

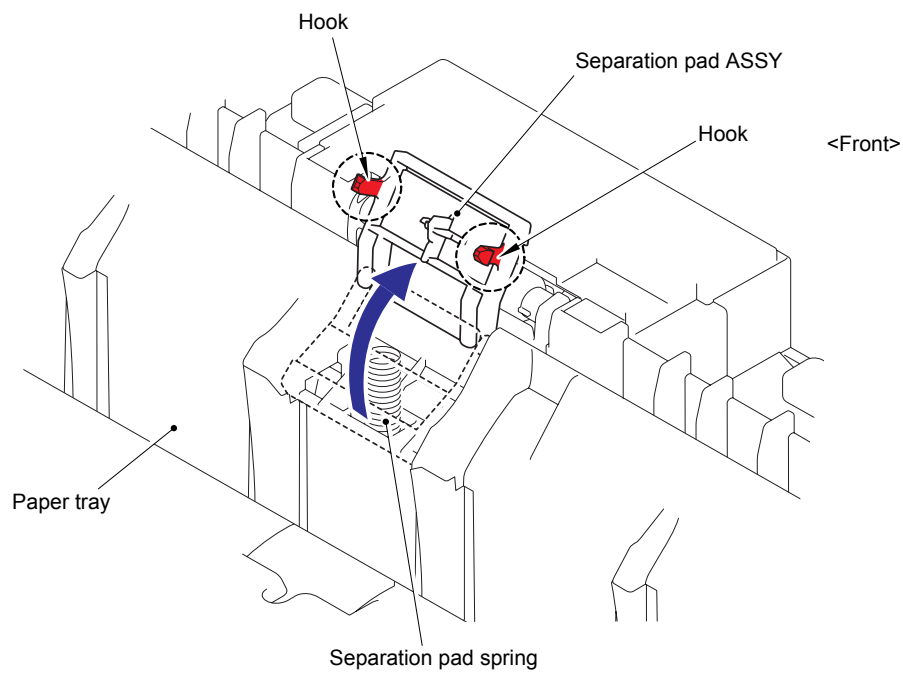

Fig. 2-51

- (3) Push both sides of the Separation pad ASSY inwards to release the Pins and remove the Separation pad ASSY from the Paper tray.
- (4) Remove the Separation pad spring from the Paper tray.

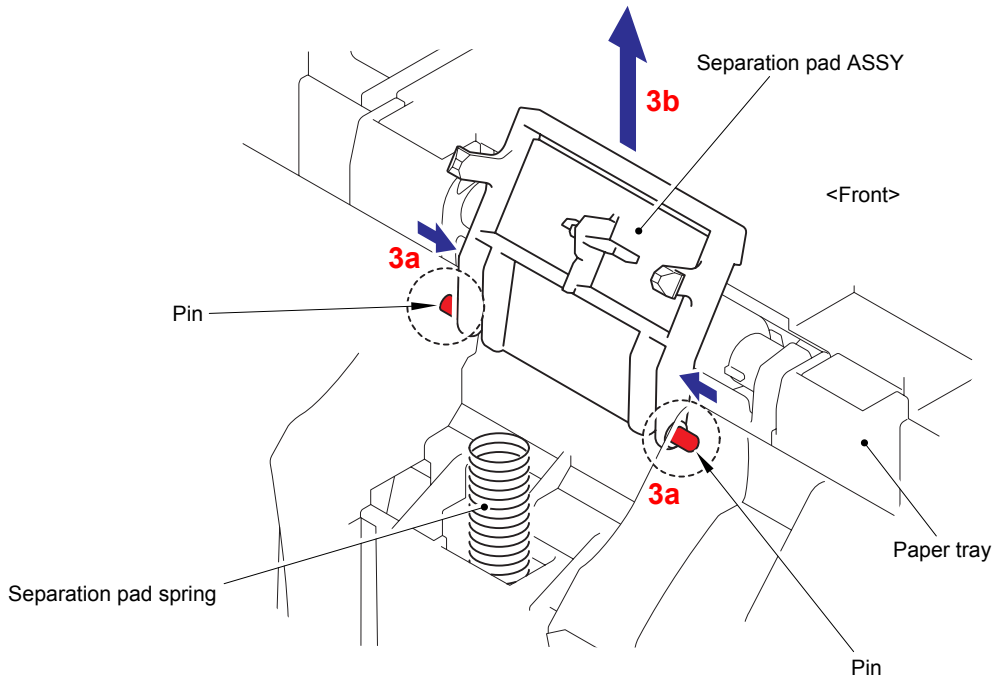

Fig. 2-52

- (5) Press the Front cover release button, and open the Front door unit ASSY.
- (6) Push the Lift arm to the direction of the arrow 6a and release the boss of the Roller holder ASSY. Then, turn the Roller holder ASSY to the direction of the arrow 6b.

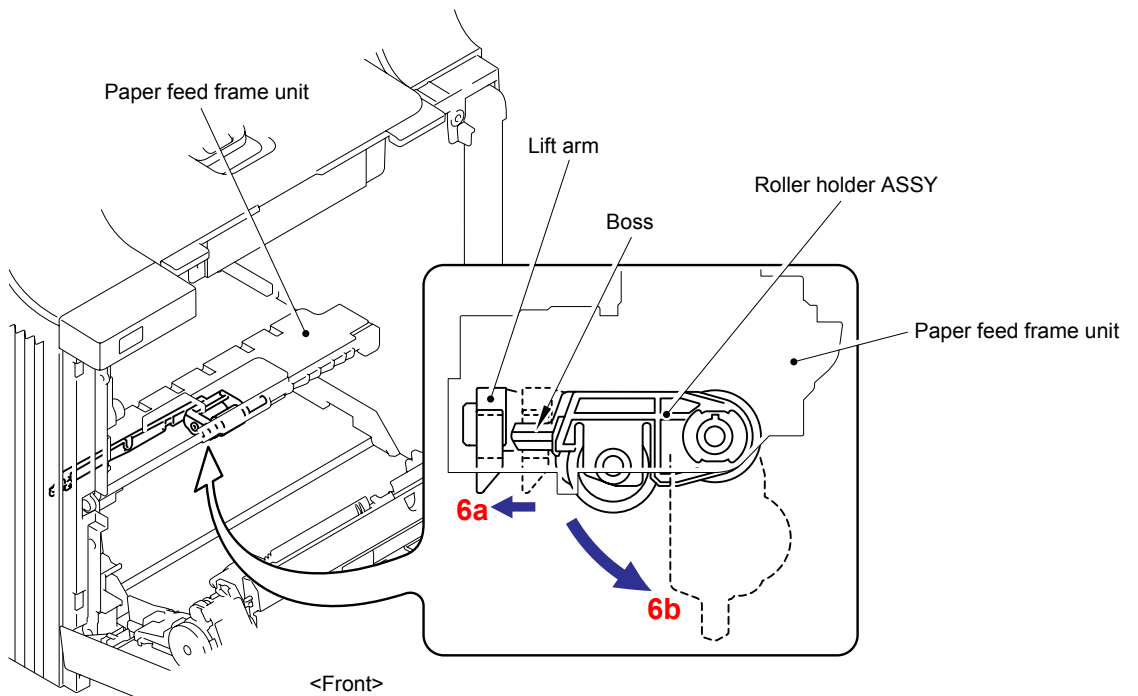

Fig. 2-53

- (7) Slide the Roller holder ASSY to the direction of the arrows 7a, 7b and 7c in this order and remove it.

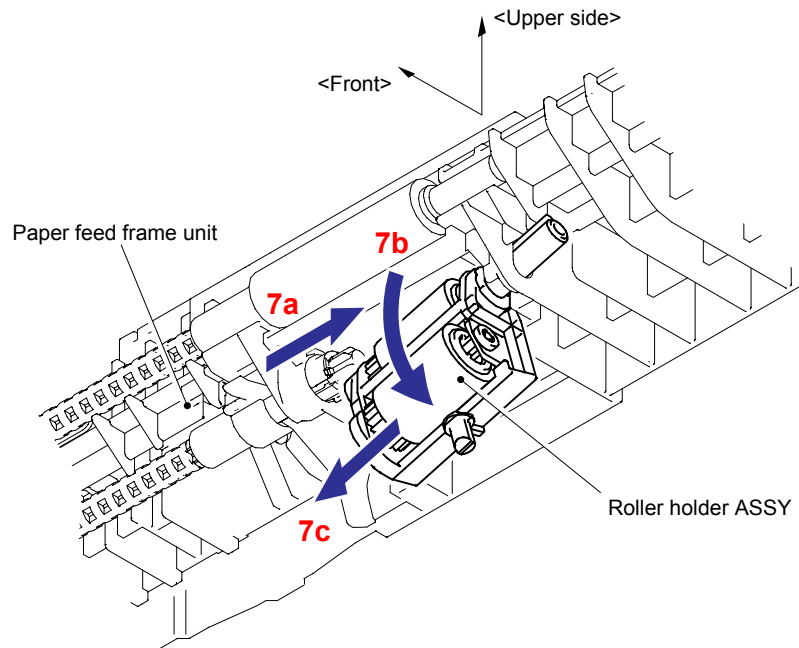

Fig. 2-54

<Installing Procedure>

- (1) Assemble the Roller holder ASSY onto the Paper feed frame unit in the order of the arrow 1a, 1b and 1c.

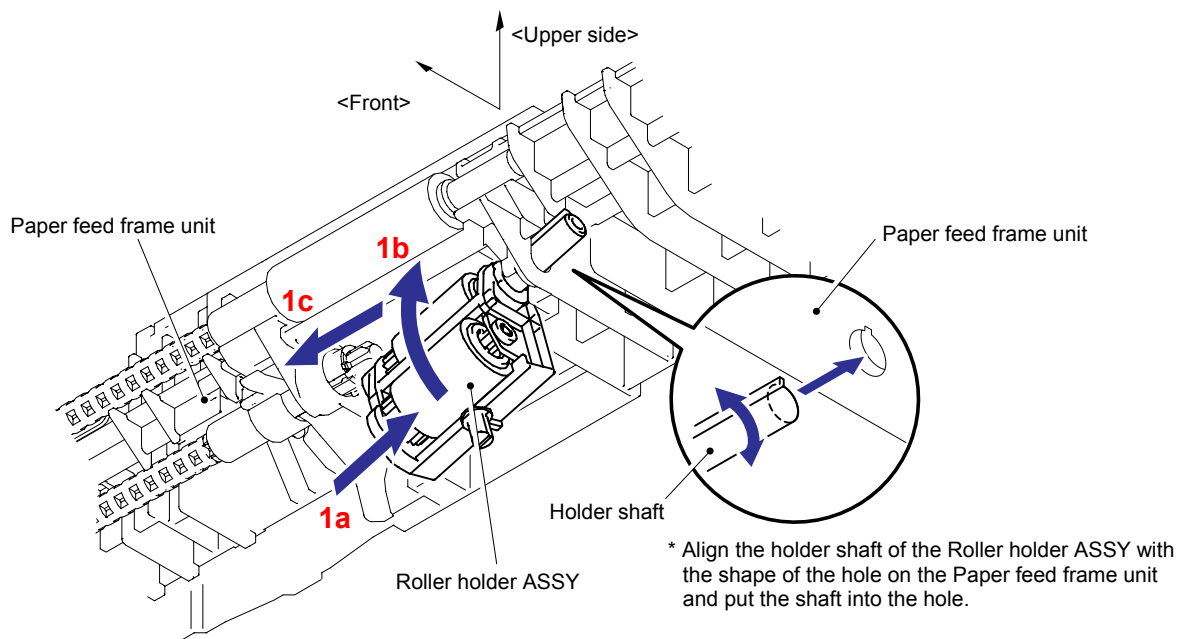

Fig. 2-55

- (2) Turn the Roller holder ASSY to the direction of the arrow 2a, push the Lift arm to the direction of the arrow 2b and fix the Boss of the Roller holder ASSY into the hole of the Lift arm.

Note:

Check whether the Lift arm moves by pushing the Roller holder ASSY upwards. If the Lift arm does not move, it is not assembled correctly.

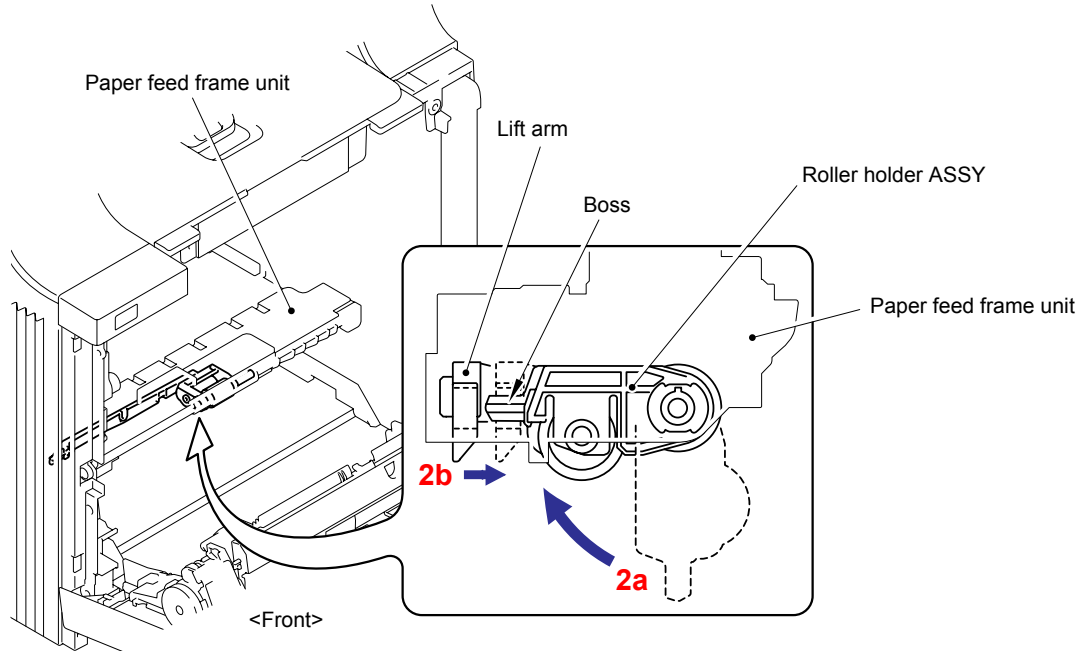

Fig. 2-56

- (3) Close the Front door unit ASSY.
- (4) Assemble the Separation pad spring. Put the positioning section of the Separation pad ASSY into the spring and catch the two Hooks.

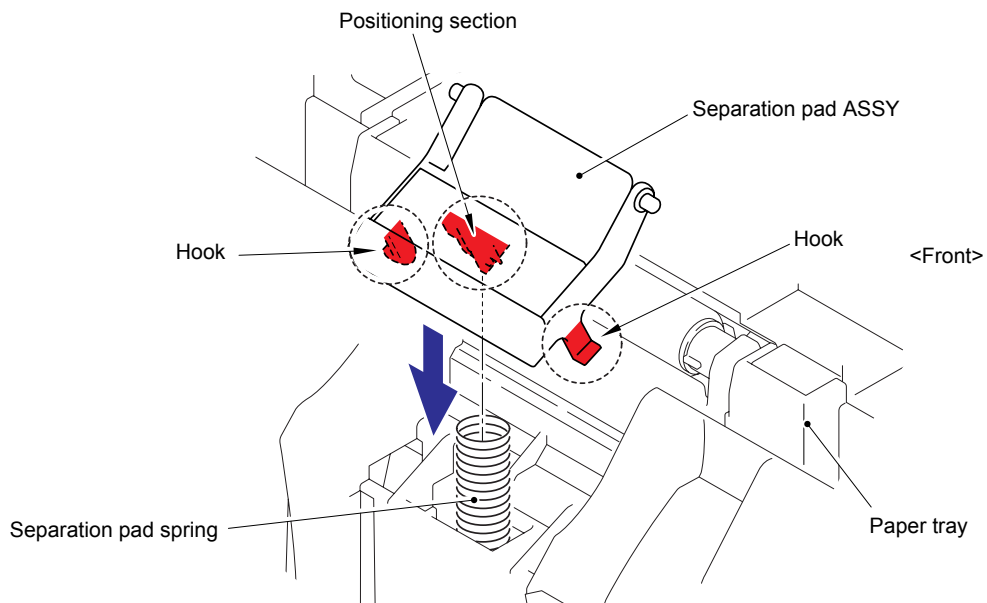

Fig. 2-57

- (5) Push both sides of the Separation pad ASSY inwards and put its Pins into the Paper tray.

Note:

Check that the Separation pad ASSY pivots up and down smoothly by pushing it gently.

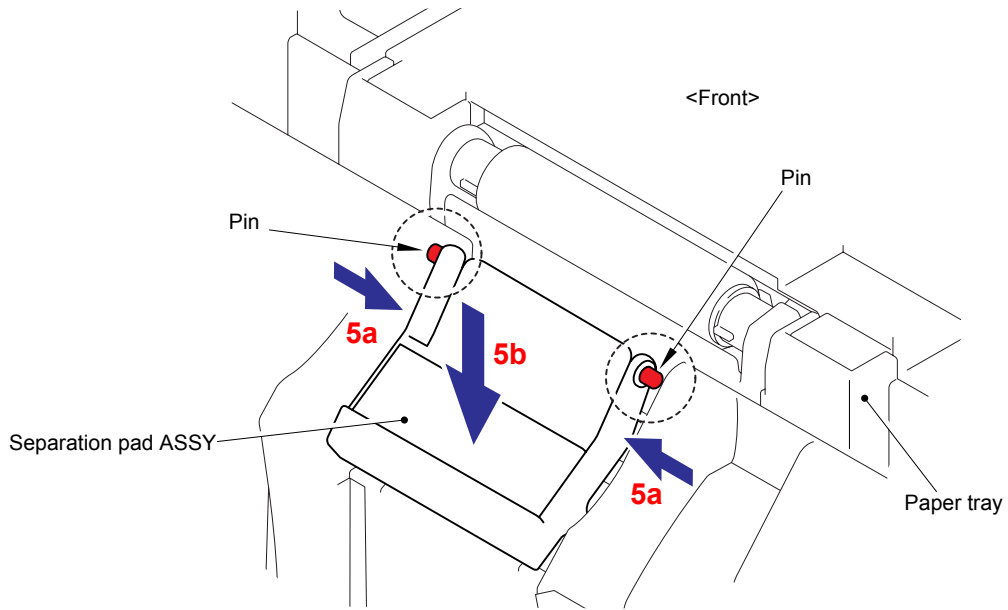

Fig. 2-58

- (6) Install the Paper tray into the machine.

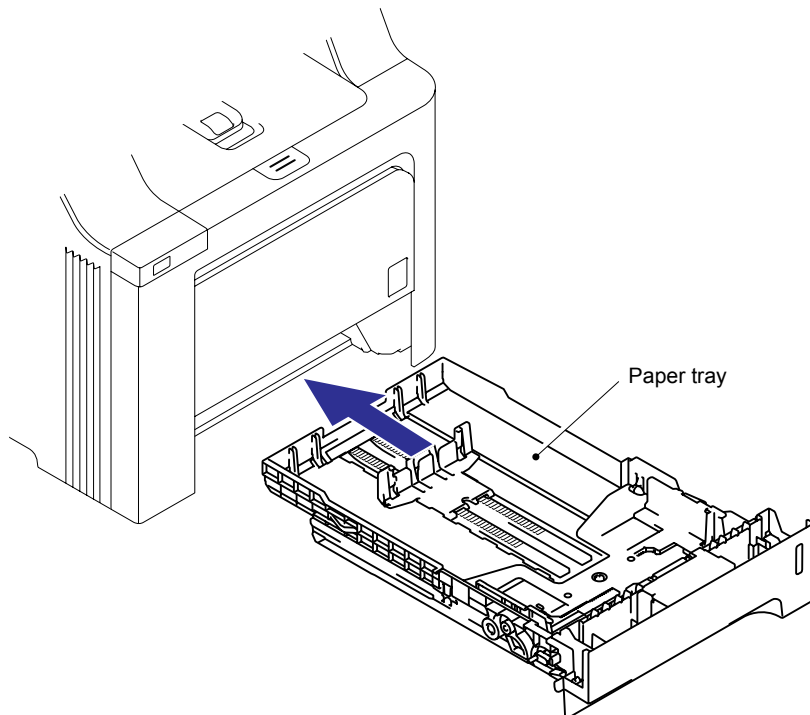

Fig. 2-59

- (7) After replacing the Paper feeding kit, reset the counter. (Refer to [“2.3 Parts Life Reset Function”](#) in this chapter.)

2.2.4 MP Paper Feeding Kit (PF kit MP)

<Uninstalling Procedure>

- (1) Press the Front cover release button, and open the Front door unit ASSY.
- (2) Release the two Hooks to remove the MP feed frame cover from the Front door unit ASSY.

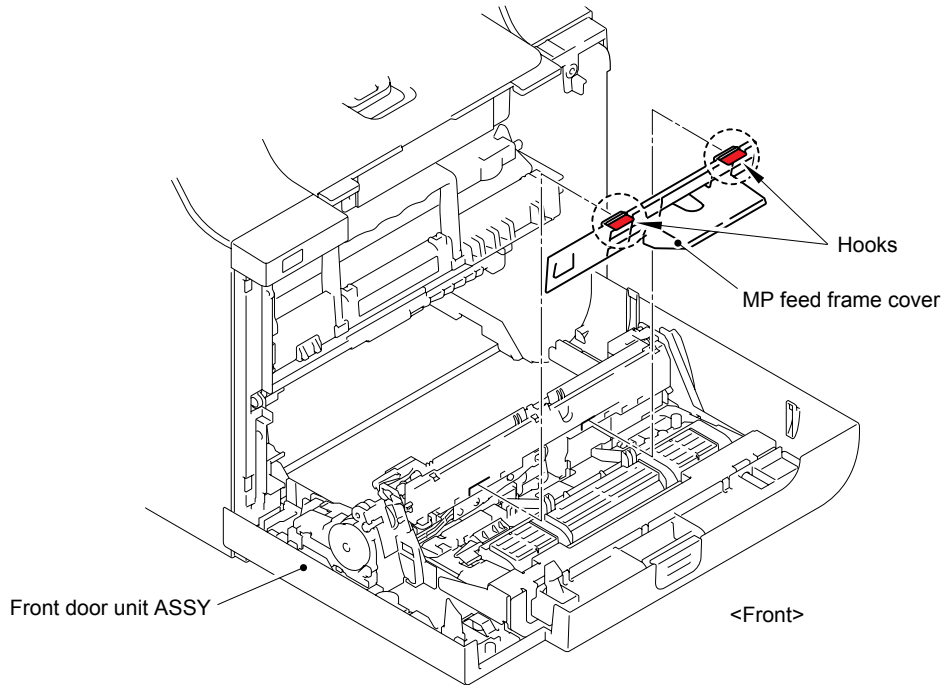

Fig. 2-60

- (3) Remove the MP lift arm 2.

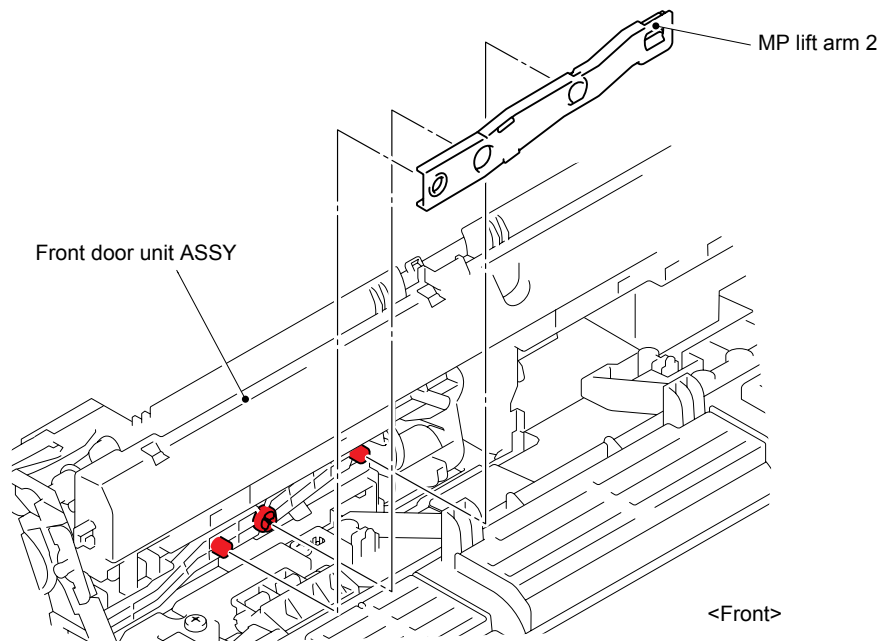

Fig. 2-61

- (4) Lift up the Hook and release it in the direction of arrow 4a. Slide the Holder bush MP in the direction of arrow 4b, and then remove the Holder bush MP from the shaft of the MP roller holder ASSY.

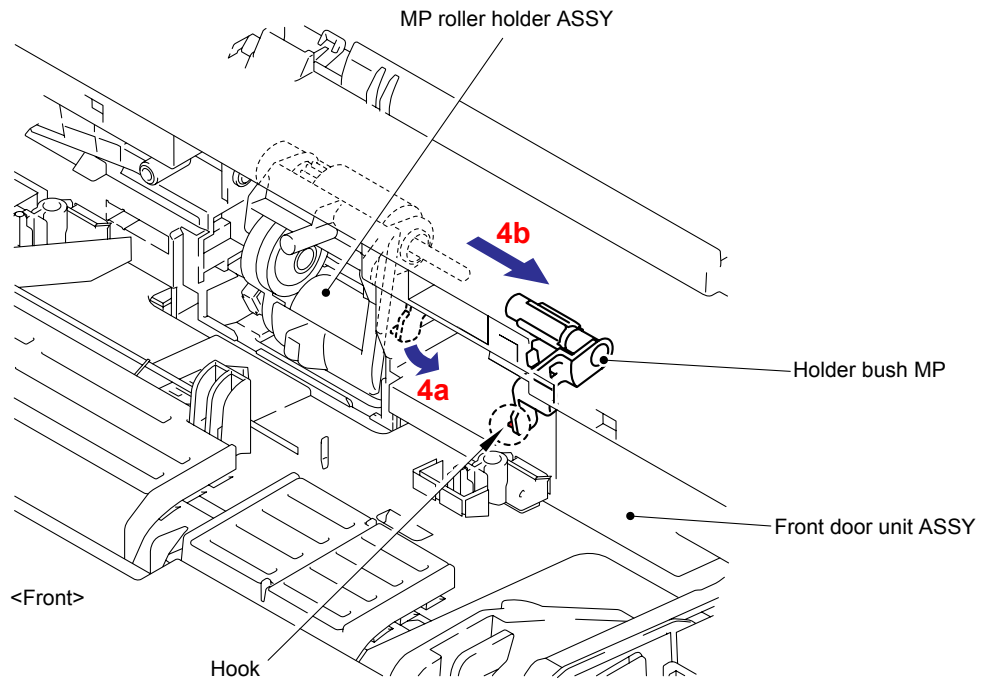

Fig. 2-62

- (5) Slide the MP roller holder ASSY in the direction of arrow 5a and slightly pull it down in the direction of arrow 5b. Then, remove it.

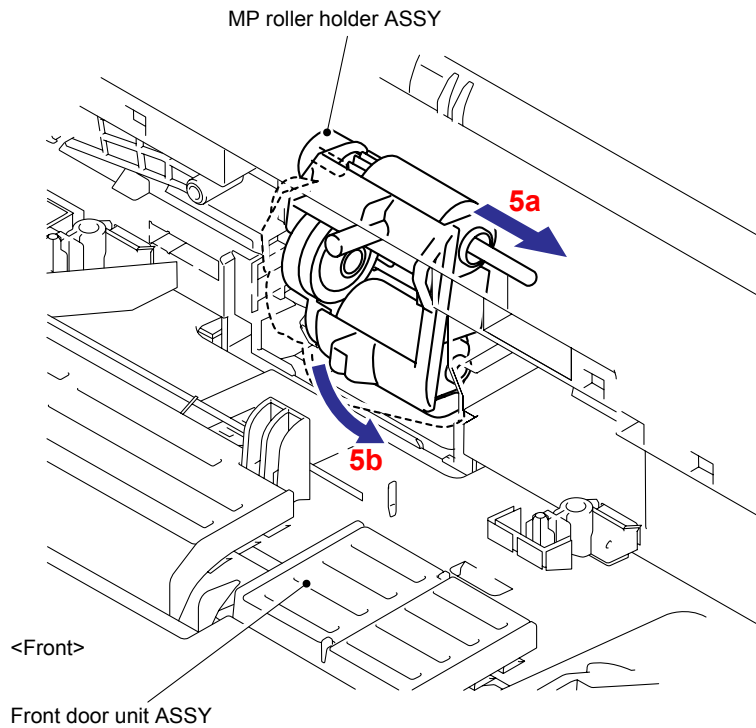

Fig. 2-63

- (6) Remove the Separation pad ASSY MP from the Front door unit ASSY.
- (7) Remove the Separation pad spring MP.

Note:

Be careful not to loose the Separation pad spring MP.

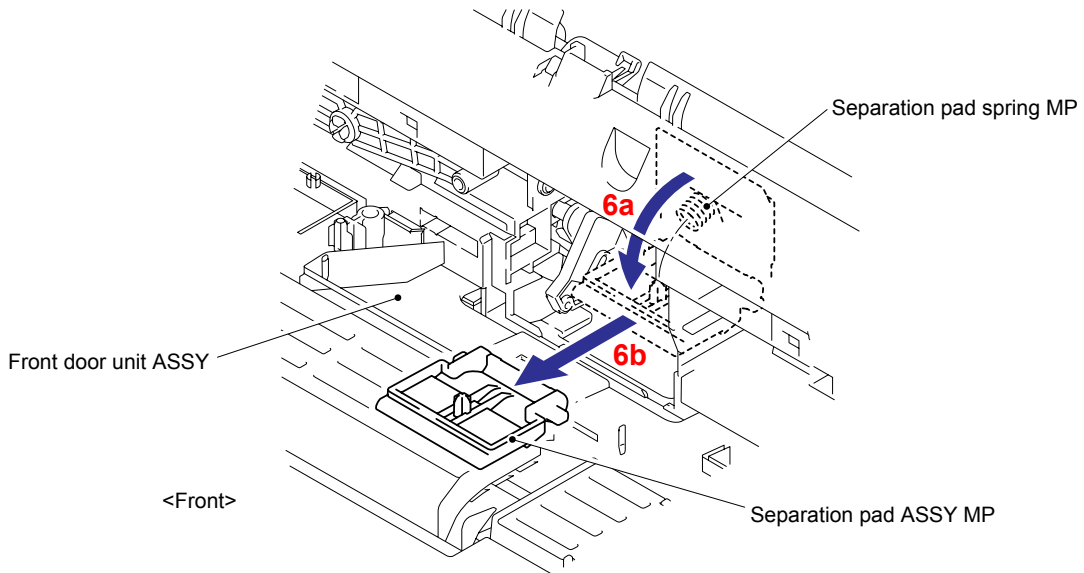

Fig. 2-64

<Installing Procedure>

- (1) Assemble the Separation pad Spring MP.
- (2) Put the positioning section of the Separation pad ASSY MP into the Separation pad spring MP and catch the two Hooks to fix the Separation pad ASSY MP.

Note:

Check that the Separation pad ASSY MP moves smoothly by pushing it up and down.

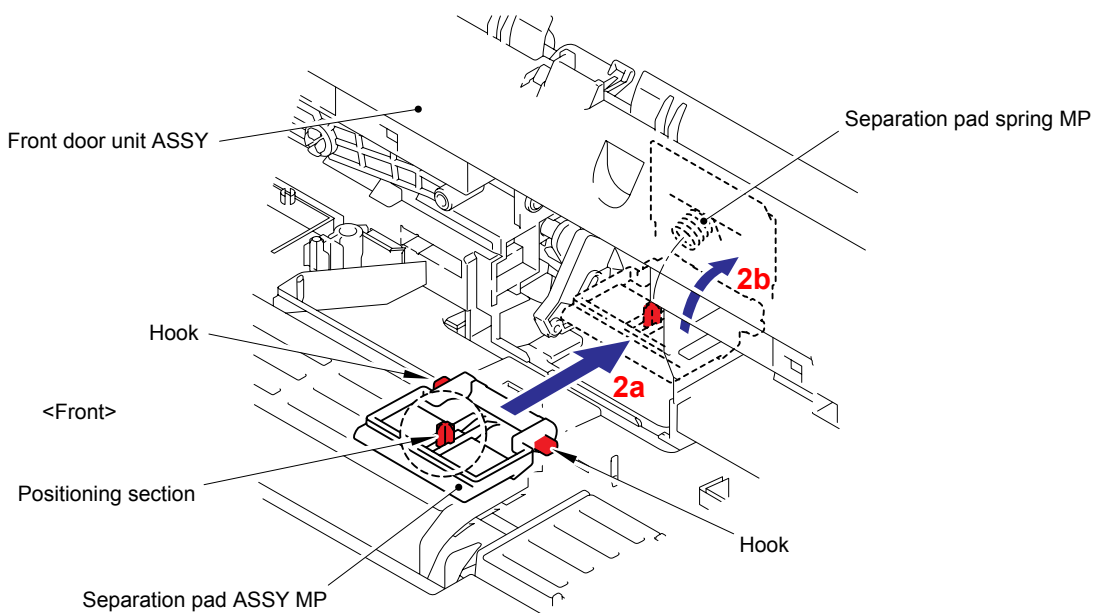

Fig. 2-65

- (3) Put the Holder shaft into the hole while holding the Separation pad ASSY MP. Slide the MP roller holder ASSY to the direction of the arrow 3b to re-assemble it.

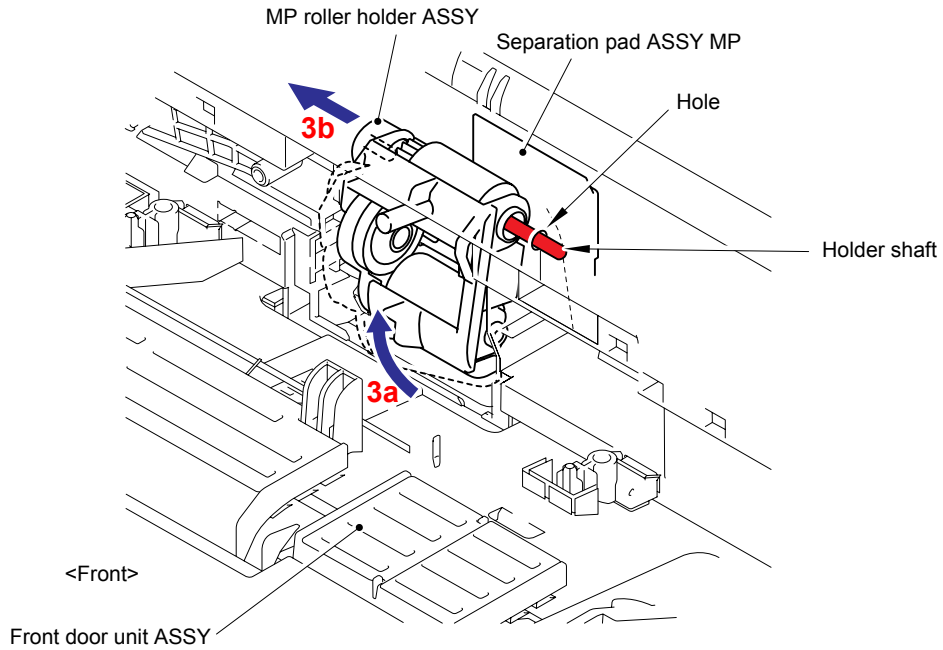

Fig. 2-66

- (4) Put into the Holder bush MP to the direction of the arrow 4a and turn it to the direction of the arrow 4b so that the Hook catches.

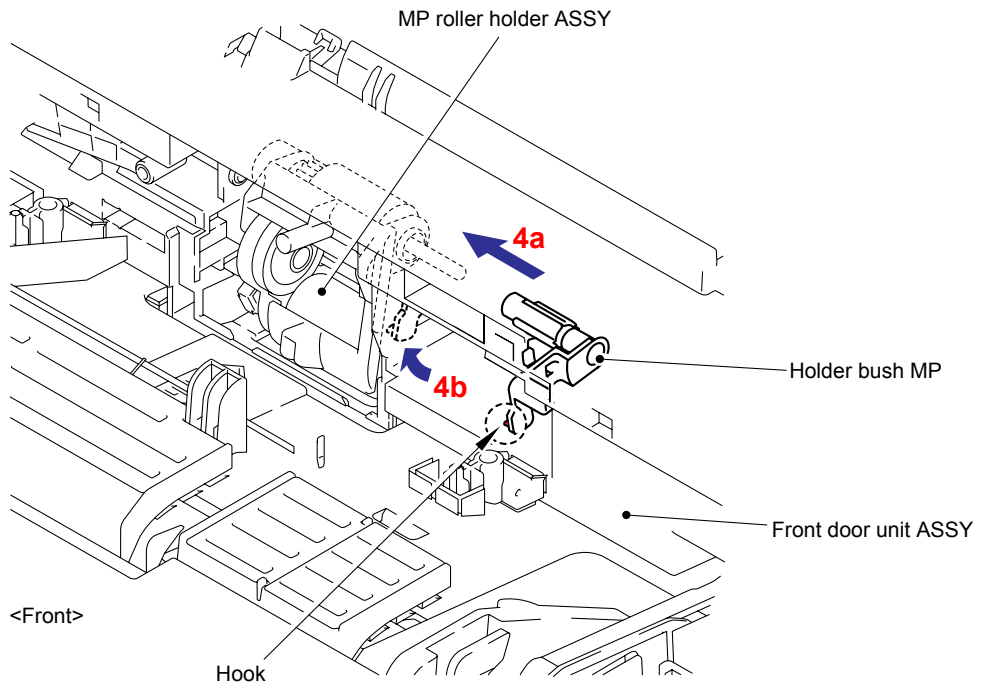

Fig. 2-67

- (5) Assemble the MP lift arm 2 with aligning it with the three Bosses provided on the Front door unit ASSY.

Note:

When assembling the MP lift arm 2, make sure that the shaft of the MP roller holder ASSY is put into the hole on the MP lift arm 2.

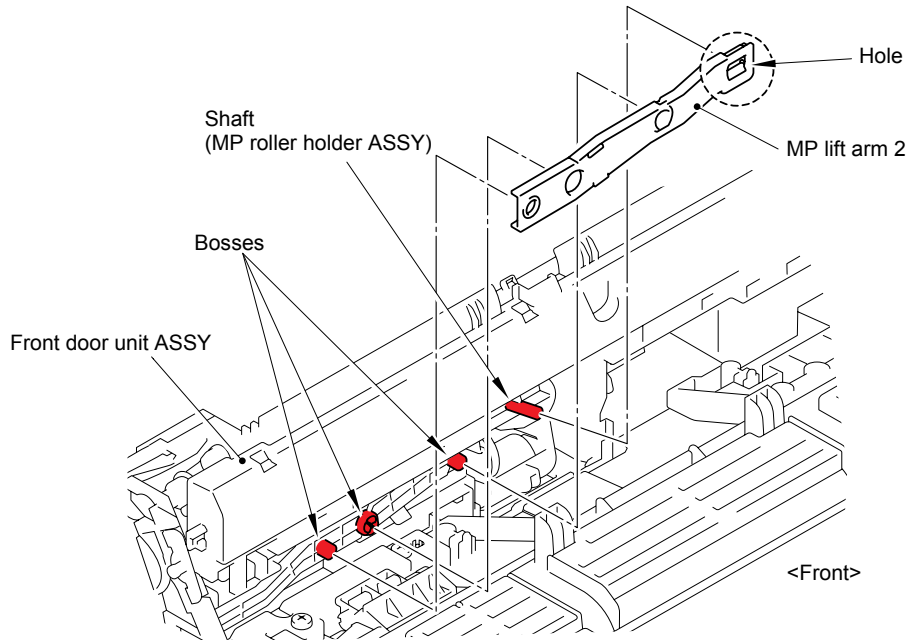

Fig. 2-68

- (6) Assemble the MP feed frame cover onto the Front door unit ASSY.
(7) Close the Front door unit ASSY.

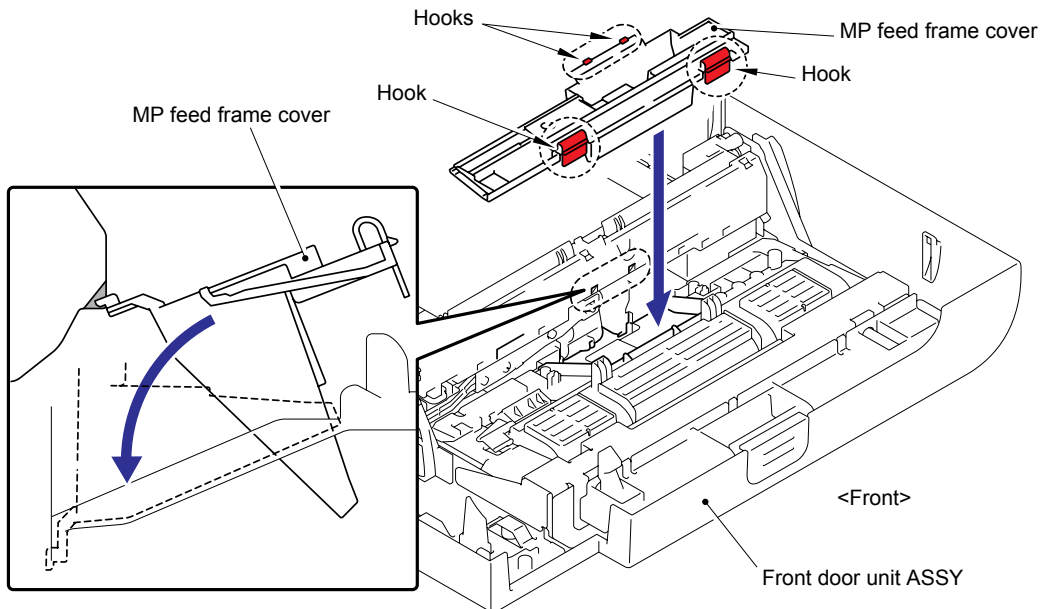

Fig. 2-69

- (8) After replacing the MP paper feeding kit, reset the counter. (Refer to [“2.3 Parts Life Reset Function”](#) in this chapter.)

2.3 Parts Life Reset Function

This function is provided for service personnel in order to reset the counter of each periodical replacement part and count the number of replacement times when replacing the periodical replacement parts.

<Operating Procedure>

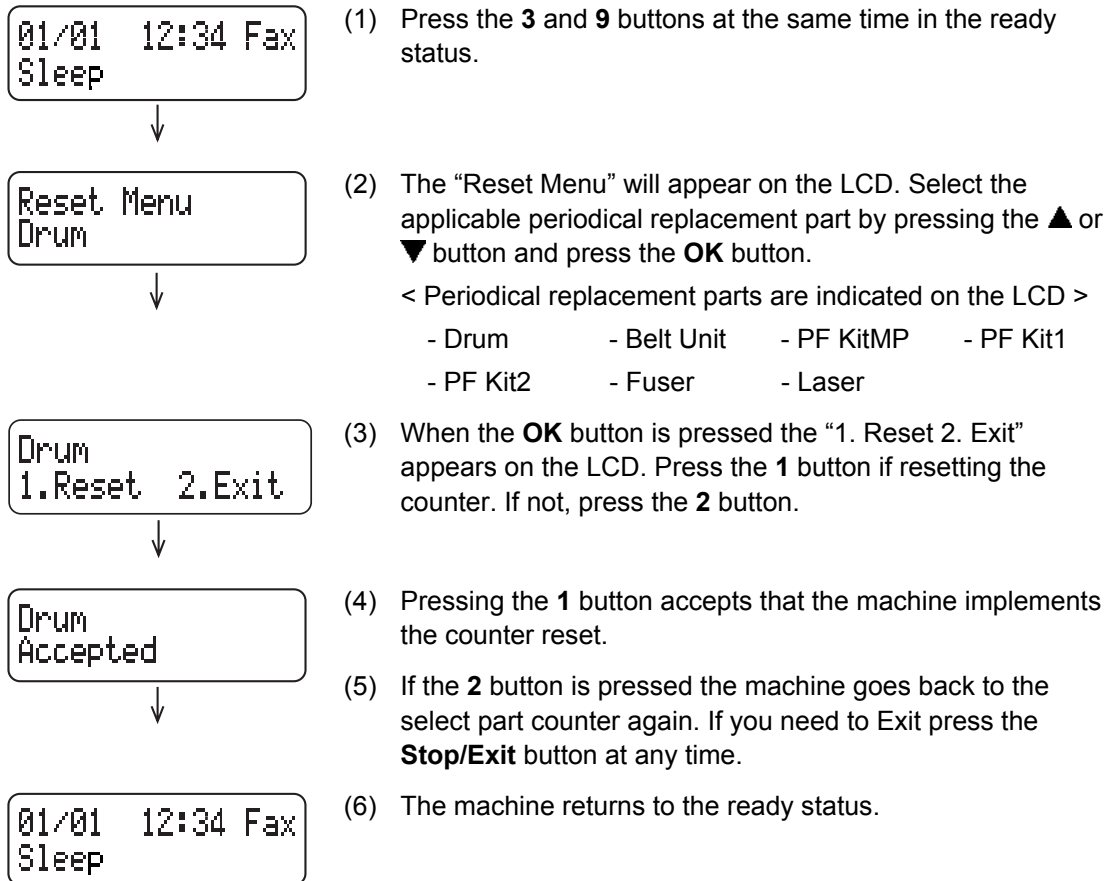

Note:

- All periodical replacement parts are always indicated on the LCD even though their lives do not reach 0 %.
- The PF kit2 is always indicated even though Tray 2 is not installed, or it is not supported for the model to be used.
- The machine returns to the ready state automatically if no panel operation is implemented for 60 seconds.

CHAPTER 3 DISASSEMBLY AND ASSEMBLY

1. SAFETY PRECAUTIONS

To avoid creating secondary problems by mishandling, follow the warnings and precautions below during maintenance work.

 **HOT SURFACE**

Some parts inside the machine are extremely hot immediately after the machine is used. When opening the front cover or back cover to access any parts inside the machine, never touch the shaded parts shown in the following figures.

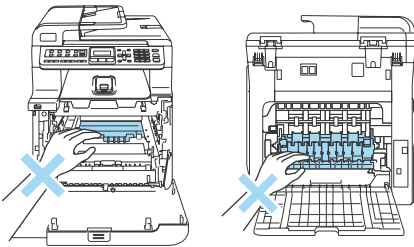

Caution:

- Be careful not to lose screws, washers, or other parts removed.
- Be sure to apply grease to the gears and applicable positions specified in this chapter.
- When using soldering irons or other heat-generating tools, take care not to accidentally damage parts such as wires, PCBs and covers.
- Static electricity charged in your body may damage electronic parts. When transporting PCBs, be sure to wrap them in conductive sheets.
- When replacing the PCB and all the other related parts, put on a grounding wrist band and perform the job on a static mat. Also take care not to touch the conductor sections on the flat cables or on the wire harness.
- After disconnecting flat cables, check that each cable is not damaged at its end or short-circuited.
- When connecting flat cables, do not insert them at an angle. After insertion, check that the cables are not at an angle.
- When connecting or disconnecting cable connectors, hold the connector body, not the cables. If the connector has a lock, release the connector lock first to release it.
- After a repair, check not only the repaired portion but also all connectors. Also check that other related portions are functioning properly before operational checks.

2. PACKING

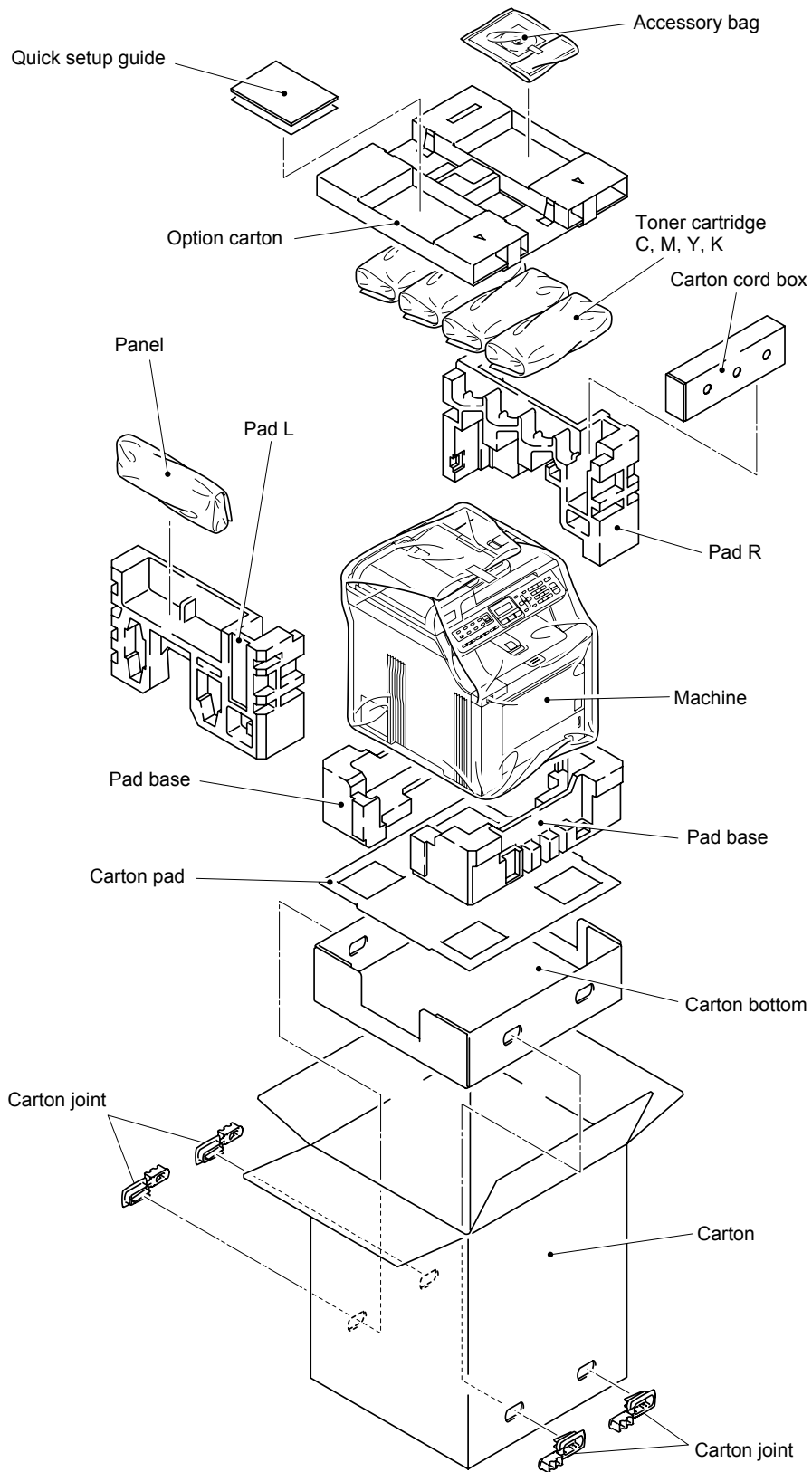

3. SCREW TORQUE LIST

Tightening Note:

When tightening any of the screws shaded in the table below, slowly turn it counterclockwise (in the direction to loosen the screw) with your hand until you feel that the screw is a little dropped in the hole. Then, slightly turn it clockwise (in the direction to tighten the screw) with your hand and tighten it according to the specified torque with a screwdriver.

Note:

For verifying the shape of each screw, refer to **"APPENDIX 4 SCREW CATALOGUE"**.

Location of screw	Screw type	Q'ty	Tightening torque N m (kgf • cm)
Tray cover ASSY	Taptite, bind B M4x12	2	0.80 ±0.1 (8 ±1)
Fuser unit	Taptite, pan B M4x14	2	1.20 ±0.1 (12 ±1)
Back cover upper	Taptite, cup S M3x8	2	0.80 ±0.1 (8 ±1)
Drive shaft holder	Taptite, bind B M3x10	1	0.60 ±0.1 (6 ±1)
Paper eject ASSY DX/SX	Taptite, cup B M4x12	2	1.20 ±0.1 (12 ±1)
	Taptite, cup S M3x6	1	0.80 ±0.1 (8 ±1)
Back cover ASSY	Taptite, cup S M3x8	2	0.80 ±0.1 (8 ±1)
Transfer HVPS PCB unit	Taptite, cup S M3x6	2	0.80 ±0.1 (8 ±1)
Earth plate 3	Taptite, bind B M3x8	1	0.60 ±0.1 (6 ±1)
Density shield plate 1	Taptite, bind B M3x8	2	0.60 ±0.1 (6 ±1)
Earth plate 2	Taptite, cup S M3x6	1	0.80 ±0.1 (8 ±1)
Registration-mark sensor PCB ASSY 1	Taptite, bind B M3x8	1	0.60 ±0.1 (6 ±1)
Registration-mark sensor PCB ASSY 2	Taptite, bind B M3x8	1	0.60 ±0.1 (6 ±1)
Density sensor	Taptite, bind B M3x8	2	0.60 ±0.1 (6 ±1)
Registration relay PCB ASSY	Taptite, bind B M3x8	1	0.60 ±0.1 (6 ±1)
Transfer HVPS PCB ASSY	Taptite, cup B M3x10	3	0.50 ±0.1 (5 ±1)
	Taptite, cup S M3x6	1	0.80 ±0.1 (8 ±1)
Side cover L ASSY	Taptite, cup B M4x12	3	0.80 ±0.1 (8 ±1)
	Taptite, cup S M3x8	1	0.80 ±0.1 (8 ±1)
Side plate LB	Taptite, cup B M4x12	1	1.20 ±0.1 (12 ±1)
	Taptite, cup S M4x8	1	1.20 ±0.1 (12 ±1)
	Taptite, cup S M3x6	3	0.80 ±0.1 (8 ±1)
Side cover R ASSY	Taptite, cup B M4x12	2	0.80 ±0.1 (8 ±1)
	Taptite, cup S M4x8	2	0.80 ±0.1 (8 ±1)
FG harness ADF	Taptite, cup S M3x6	1	0.80 ±0.1 (8 ±1)
Document scanner hinge	Taptite, bind B M4x12	2	0.80 ±0.1 (8 ±1)
Hinge ASSY L	Taptite, cup B M3x10	3	0.50 ±0.1 (5 ±1)
Hinge ASSY R	Taptite, cup B M3x10	3	0.50 ±0.1 (5 ±1)
ADF front cover	Taptite, cup B M3x10	2	0.50 ±0.1 (5 ±1)
ADF side cover	Taptite, cup B M3x10	3	0.50 ±0.1 (5 ±1)
Upper document chute	Taptite, cup B M3x10	4	0.50 ±0.1 (5 ±1)
Lower document chute	Taptite, cup B M3x10	2	0.50 ±0.1 (5 ±1)
FG harness ADF	Taptite, cup S M3x6	1	0.80 ±0.1 (8 ±1)

Location of screw	Screw type	Q'ty	Tightening torque N m (kgf • cm)
Drive frame ASSY	Taptite, cup B M3x10	2	0.50 ±0.1 (5 ±1)
ADF motor	Taptite, bind S M3x6	1	0.70 ±0.1 (7 ±1)
Driver PCB ASSY	Taptite, cup S M3x6	2	0.80 ±0.1 (8 ±1)
FG harness FB	Taptite, cup S M3x6	1	0.80 ±0.1 (8 ±1)
Panel unit	Taptite, cup B M3x10	5	0.50 ±0.1 (8 ±1)
NCU cover	Taptite, cup B M3x8	4	0.60 ±0.1 (6 ±1)
NCU unit	Taptite, bind B M4x12	2	0.80 ±0.1 (8 ±1)
FG harness NCU	Screw pan (S/P washer) M3.5x6	1	0.80 ±0.1 (8 ±1)
NCU shield	Screw pan (S/P washer) M3.5x6	1	0.80 ±0.1 (8 ±1)
NCU PCB ASSY	Taptite, cup S M3x6	2	0.60 ±0.1 (6 ±1)
Joint sub cover	Taptite, cup S M3x8	1	0.80 ±0.1 (8 ±1)
Joint cover ASSY	Taptite, cup S M3x8	2	0.80 ±0.1 (8 ±1)
	Taptite, cup S M3x6	6	0.80 ±0.1 (8 ±1)
	Taptite, cup S M4x8	6	0.98 ±0.1 (9.8 ±1)
Speaker holder	Taptite, bind B M4x12	2	0.80 ±0.1 (8 ±1)
Top cover USB front ASSY	Taptite, bind B M3x8	3	0.50 ±0.1 (5 ±1)
USB holder	Taptite, bind B M3x8	3	0.50 ±0.1 (5 ±1)
Paper chute	Taptite, cup B M3x8	2	0.60 ±0.1 (6 ±1)
Stack lever holder L	Taptite, cup B M3x6	1	0.50 ±0.1 (5 ±1)
Stack lever holder R	Taptite, cup B M3x6	1	0.50 ±0.1 (5 ±1)
Earth spring	Taptite, bind B M3x8	1	0.60 ±0.1 (6 ±1)
Paper feed frame unit	Taptite, bind B M3x10	2	0.70 ±0.1 (7 ±1)
	Taptite, cup S M3x6	1	0.70 ±0.1 (7 ±1)
PF plate	Taptite, bind B M3x8	5	0.40 ±0.1 (4 ±1)
Belt cleaner release sensor PCB ASSY	Taptite, bind B M3x8	1	0.50 ±0.1 (5 ±1)
THM/HUM sensor holder ASSY	Taptite, cup S M3x6	4	0.69 ±0.1 (6.9 ±1)
THM/HUM ground plate	Taptite, cup S M3x6	1	0.69 ±0.1 (6.9 ±1)
Release rack plate	Taptite, cup B M3x8	1	0.49 ±0.1 (4.9 ±1)
Front door unit earth	Taptite, cup S M3x6	1	0.80 ±0.1 (8 ±1)
Wire support rope	Shoulder screw	1	0.80 ±0.1 (8 ±1)
Harness cover MP	Taptite, cup S M3x6	1	0.78 ±0.1 (7.8 ±1)
Front door sub	Taptite, cup B M4x10	5	0.59 ±0.1 (5.9 ±1)
	Taptite, cup B M3x8	1	0.39 ±0.1 (3.9 ±1)
EL electrode spring cover ASSY	Taptite, bind B M3x8	2	0.392 ±0.098 (3.92 ±0.98)
EL spring harness ASSY	Taptite, bind B M3x8	2	0.392 ±0.098 (3.92 ±0.98)
Front door main	Taptite, bind B M4x10	2	0.59 ±0.1 (5.9 ±1)
Hook cover	Taptite, cup B M4x10	2	0.59 ±0.1 (5.9 ±1)
Engine PCB ASSY	Taptite, cup S M3x6	5	0.80 ±0.1 (8 ±1)
Ground plate	Taptite, cup S M3x6	1	0.80 ±0.1 (8 ±1)
	Taptite, bind B M4x12	1	1.20 ±0.1 (12 ±1)
Ground spring plate	Taptite, cup S M3x6	1	0.80 ±0.1 (8 ±1) (Frame unit side)
		1	0.50 ±0.1 (5 ±1) (Main PCB ASSY side)
Main PCB ASSY	Taptite, cup S M3x6	1	0.80 ±0.1 (8 ±1)

Location of screw	Screw type	Q'ty	Tightening torque N m (kgf • cm)
Hook slope	Taptite, cup S M3x8	4	0.70 ±0.1 (7 ±1)
Scanner cover	Taptite, cup S M3x6	8	0.90 ±0.1 (9 ±1) (Top side)
		1	0.80 ±0.1 (8 ±1) (Front side)
Laser unit	Taptite, cup S M3x6 SR	7	0.80 ±0.1 (8 ±1)
Develop gear plate ASSY	Taptite, cup S M3x6	7	0.80 ±0.1 (8 ±1)
Develop drive motor ASSY	Taptite, cup S M3x6	3	0.70 ±0.1 (7 ±1)
Gear guide holder	Taptite, cup B M3x10	5	0.70 ±0.1 (7 ±1)
Harness shield plate	Taptite, cup S M3x6	2	0.80 ±0.1 (8 ±1) (Frame unit side)
		1	0.50 ±0.1 (5±1) (Main shield side)
Engine PCB plate	Taptite, cup S M3x6	4	0.80 ±0.1 (8 ±1)
Drum drive motor 1, 2	Taptite, cup S M3x6	4	0.70 ±0.1 (7 ±1)
Drum drive ASSY	Taptite, bind B M4x12	6	1.20 ±0.1 (12 ±1)
Drum phase sensor PCB ASSY 1, 2	Taptite, bind S M3x6	2	0.70 ±0.1 (7 ±1)
Drive frame unit ASSY	Taptite, bind B M4x12	3	1.20 ±0.1 (12 ±1)
Paper feed/belt cleaner motor ASSY	Taptite, cup S M3x6	4	0.60 ±0.1 (6 ±1)
Develop release sensor PCB ASSY	Taptite, cup B M3x8	1	0.60 ±0.1 (6 ±1)
Develop press drive L ASSY	Taptite, bind B M3x12	3	0.80 ±0.1 (8 ±1)
	Taptite, cup B M3x12	1	0.80 ±0.1 (8 ±1)
Develop release motor ASSY	Taptite, bind S M3x6	1	0.70 ±0.1 (7 ±1)
Release drive holder	Taptite, cup B M3x10	3	0.70 ±0.1 (7 ±1)
Toner sensor PCB ASSY (TE/NEW)	Taptite, bind B M3x8	3	0.55 ±0.05 (5.5 ±0.5)
	Taptite, cup B M3x8	1	0.55 ±0.05 (5.5 ±0.5)
Side plate R ASSY	Taptite, cup S M3x6	2	0.75 ±0.05 (7.5 ±0.5) (Back side)
	Taptite, cup S M3x6	2	0.90 ±0.1 (9 ±1) (Front side)
	Taptite, cup B M4x12	4	0.90 ±0.1 (9 ±1)
	Taptite, cup S M4x8	1	1.20 ±0.1 (12 ±1)
	Screw pan (S/P washer) M4x8	2	0.80 ±0.1 (8 ±1)
Drum lock lever R	Screw, bind M3x8	1	0.69 ±0.1 (6.9 ±1)
Drum lock lever L	Screw, bind M3x8	1	0.69 ±0.1 (6.9 ±1)
Charge HVPS PCB ASSY	Taptite, cup S M3x6	1	0.80 ±0.1 (8 ±1)
	Taptite, bind B M4x12	2	1.20 ±0.1 (12 ±1)
Toner LED PCB	Screw pan (S/P washer) M3x16	4	0.50 ±0.1 (5 ±1)
Power inlet socket	Taptite, flat B M3x10	2	0.60 ±0.1 (6 ±1)
Ground terminal	Screw pan (S/P washer) M4x8	1	0.80 ±0.1 (8 ±1)
PS PCB unit	Taptite, bind B M4x12	3	0.90 ±0.1 (9 ±1)
Belt gear plate ASSY	Taptite, cup B M4x12	3	1.20 ±0.1 (12 ±1)
	Screw, cup M3x6	1	0.70 ±0.1 (7 ±1)
LV fan duct	Taptite, bind B M3x10	1	0.80 ±0.1 (8 ±1)
Belt unit drive motor ASSY	Taptite, cup B M4x12	3	1.20 ±0.1 (12 ±1)
Belt unit drive motor	Screw, bind M3x5	2	0.70 ±0.1 (7 ±1)

LT paper tray

Location of screw	Screw type	Q'ty	Tightening torque N m (kgf • cm)
Pinch roller holder cover LT	Taptite, bind B M4x10	2	0.70 ±0.1 (7 ±1)
LT cover rear	Shoulder screw	4	0.80 ±0.1 (8 ±1)
LT cover left	Shoulder screw	3	0.80 ±0.1 (8 ±1)
LT cover right	Shoulder screw	3	0.80 ±0.1 (8 ±1)
LT relay PCB ASSY	Taptite, cup S M3x6	1	0.80 ±0.1 (8 ±1)
Solenoid holder ASSY	Taptite, cup S M3x6	1	0.80 ±0.1 (8 ±1)
LT Solenoid ASSY	Screw flanged M3x3.5	1	0.50 ±0.1 (5 ±1)
LT tray guide left rear ASSY	Taptite, cup S M3x8	3	0.80 ±0.1 (8 ±1)
LT front cover, LT beam F	Taptite, cup S M3x6	4	0.80 ±0.1 (8 ±1)
LT frame unit	Taptite, cup S M3x6	7	0.80 ±0.1 (8 ±1)
	Taptite, bind B M4x10	1	0.80 ±0.1 (8 ±1)
LT beam R	Taptite, cup S M3x6	2	0.80 ±0.1 (8 ±1)

4. LUBRICATION

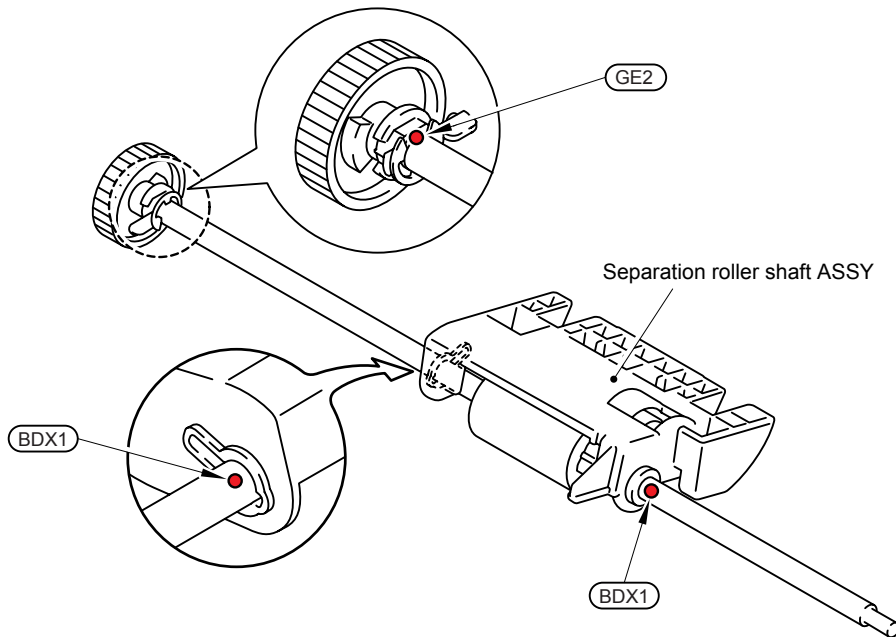

GE2: GE-676 (2mm dia. ball)

BDX1: BDX-313 (1mm dia. ball)

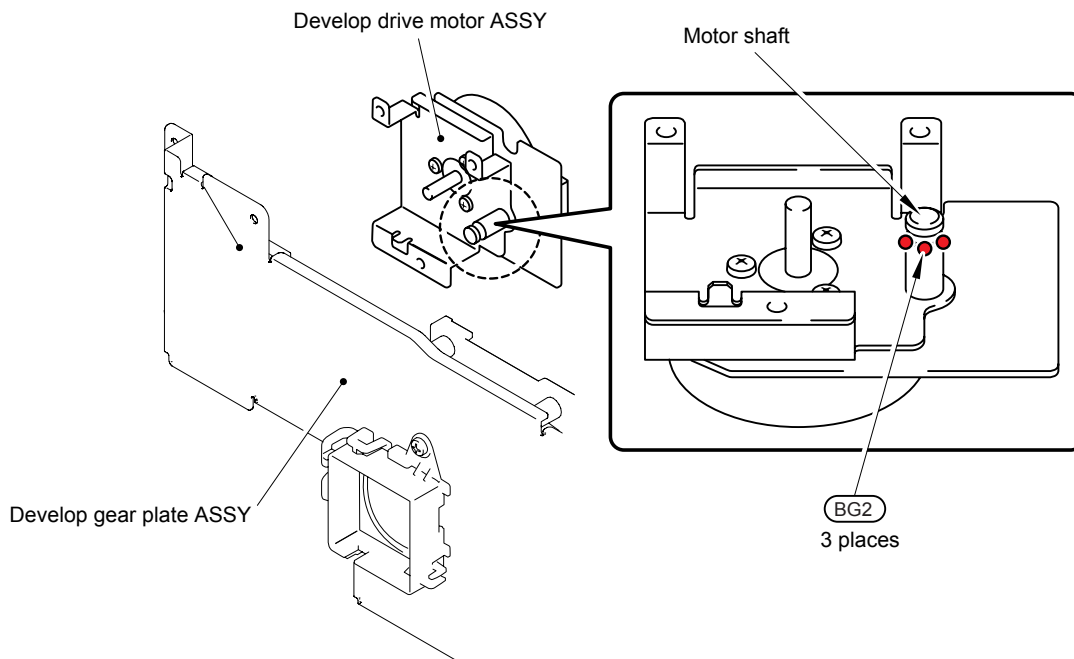

BG2: BG-MU (2mm dia. ball)

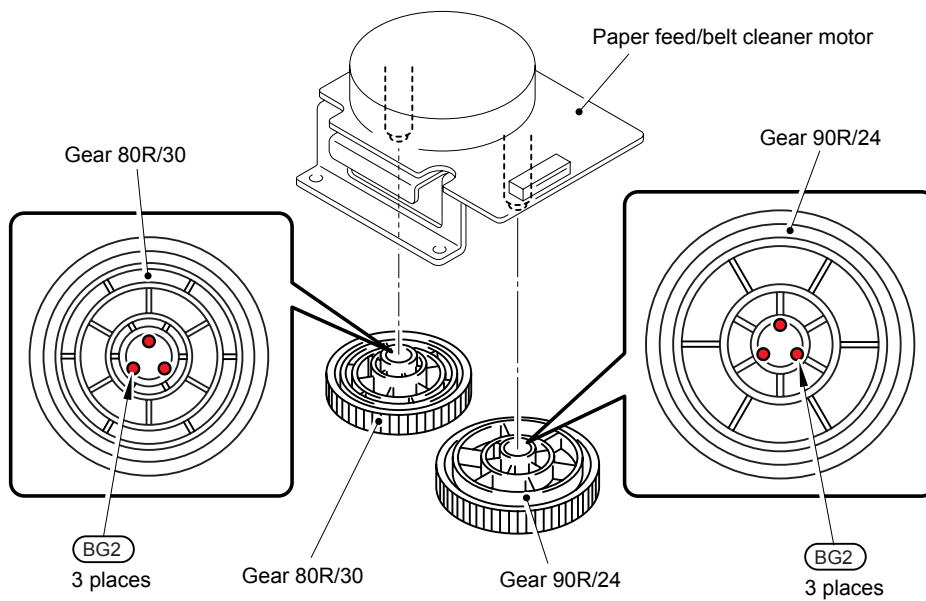

BG2: BG-MU (2mm dia. ball)

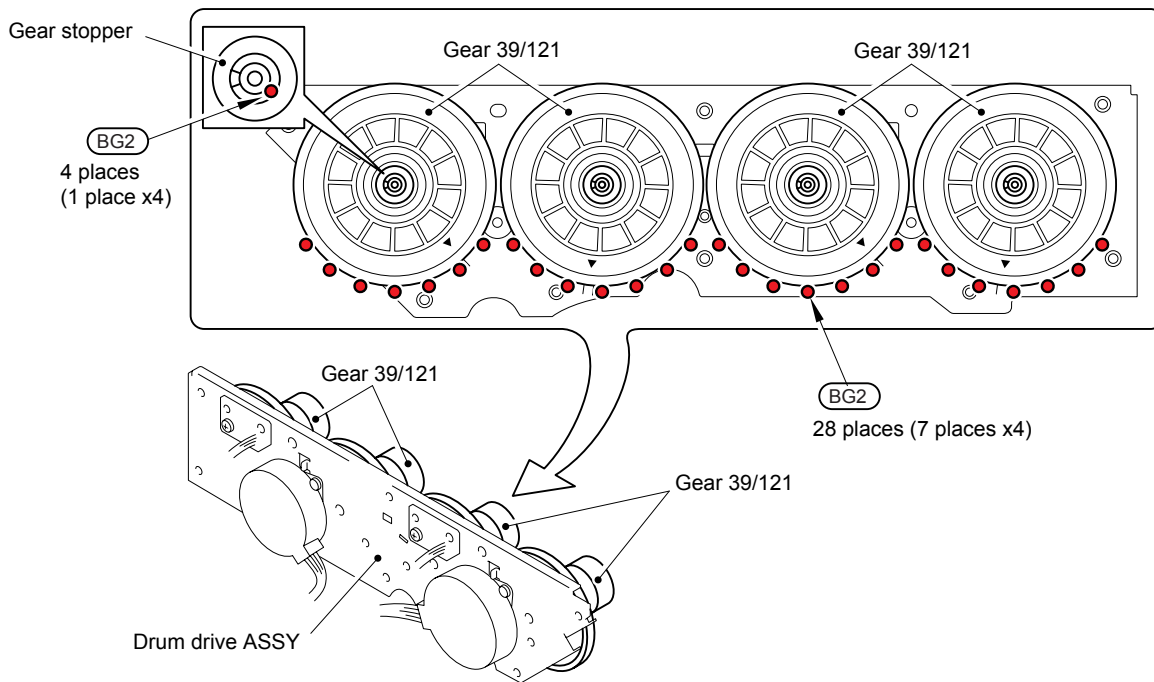

BG2: BG-MU (2mm dia. ball)

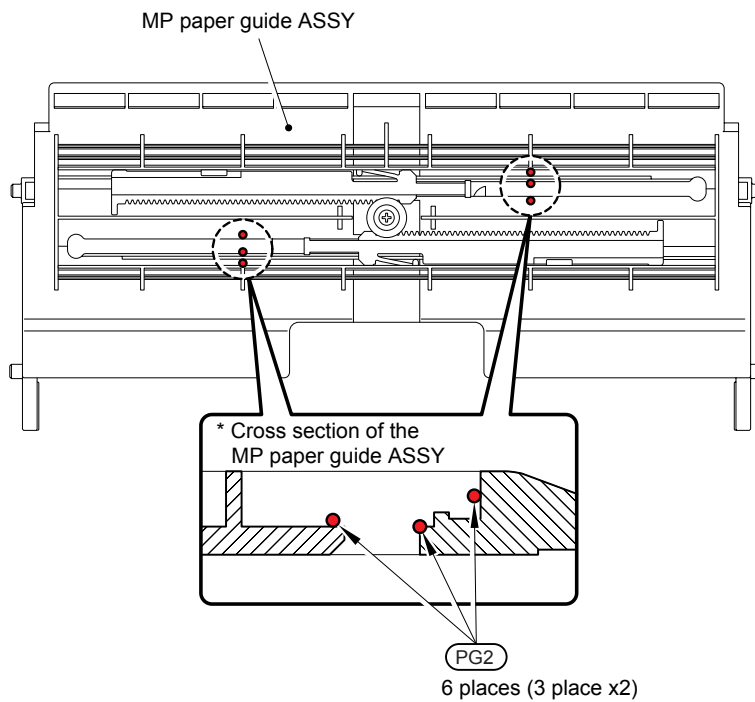

PG2: PG-661(W) (2mm dia. ball)

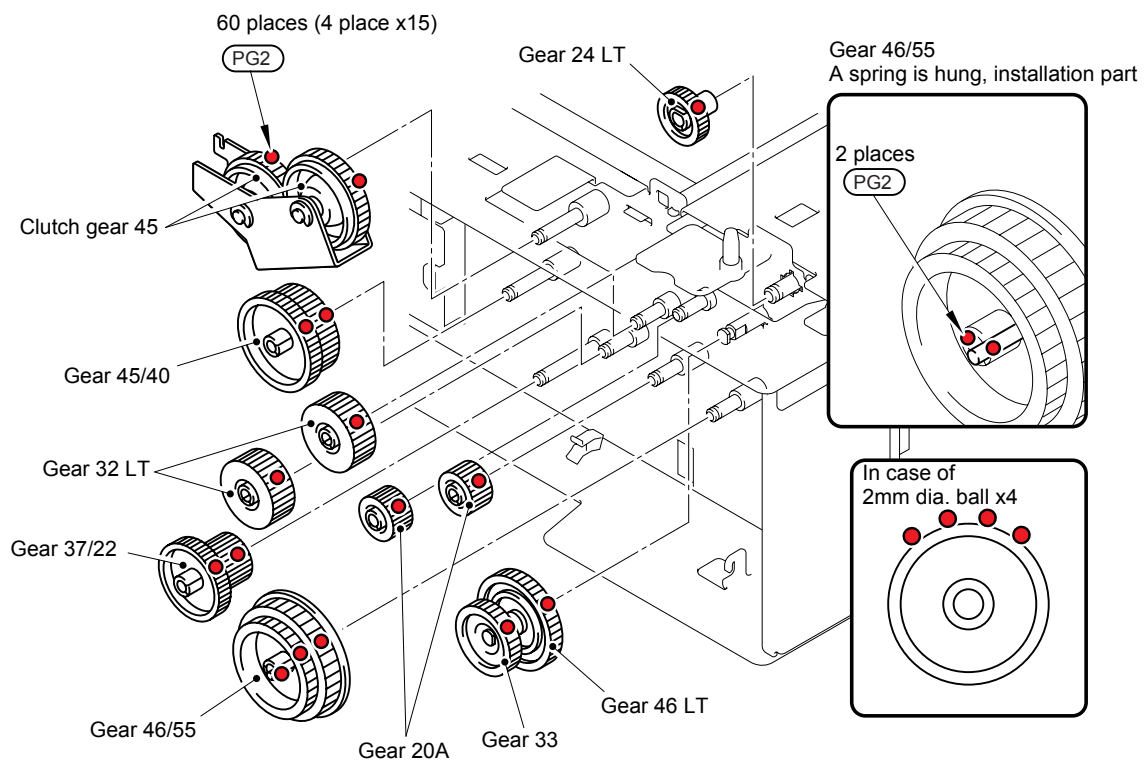

PG2: PG-661(W) (2mm dia. ball)

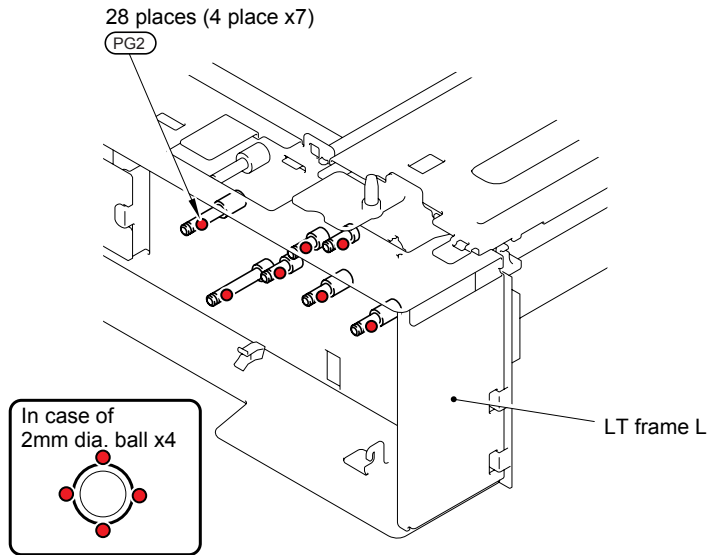

PG2: PG-661(W) (2mm dia. ball)

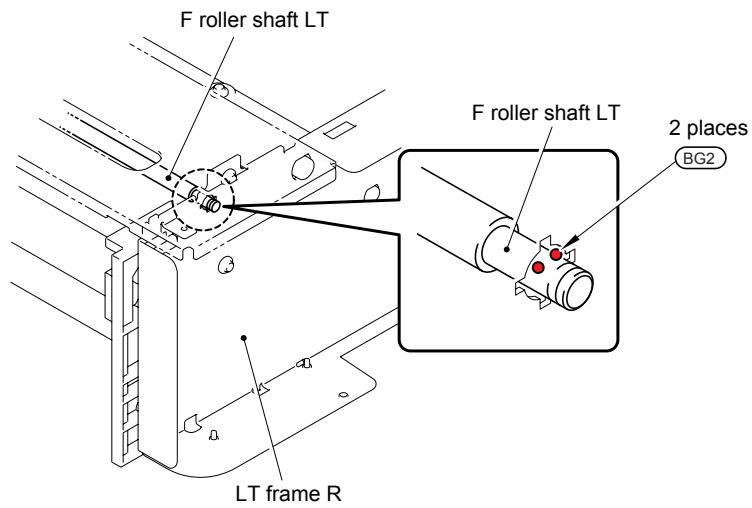

BG2: BG-MS (2mm dia. ball)

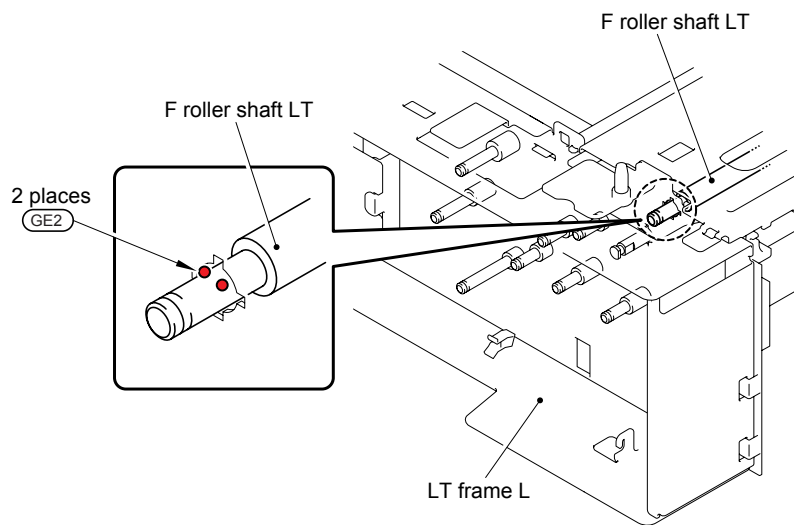

GE2: GE-676 (2mm dia. ball)

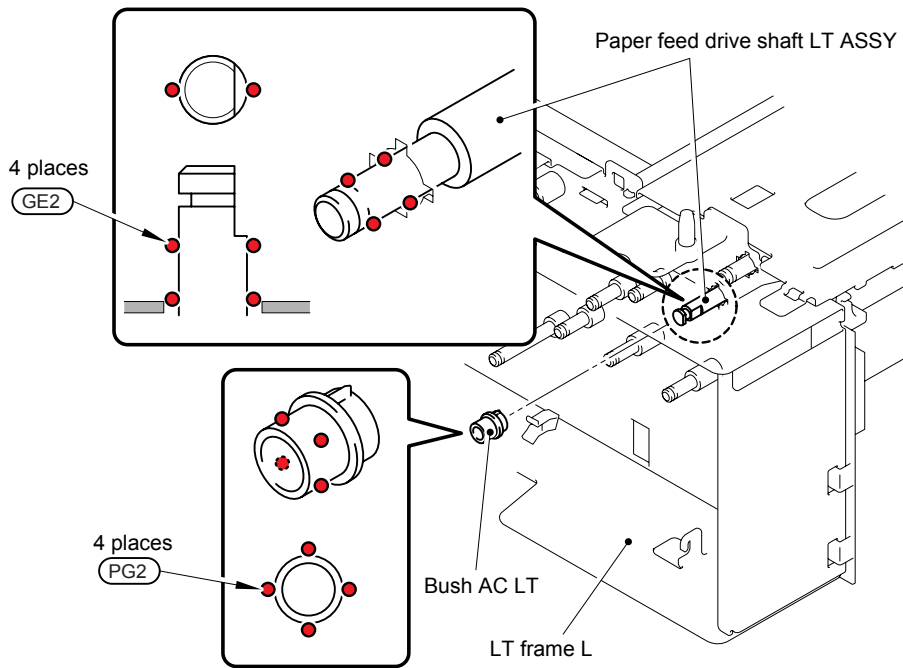

GE2: GE-676 (2mm dia. ball)

PG2: PG-661(W) (2mm dia. ball)

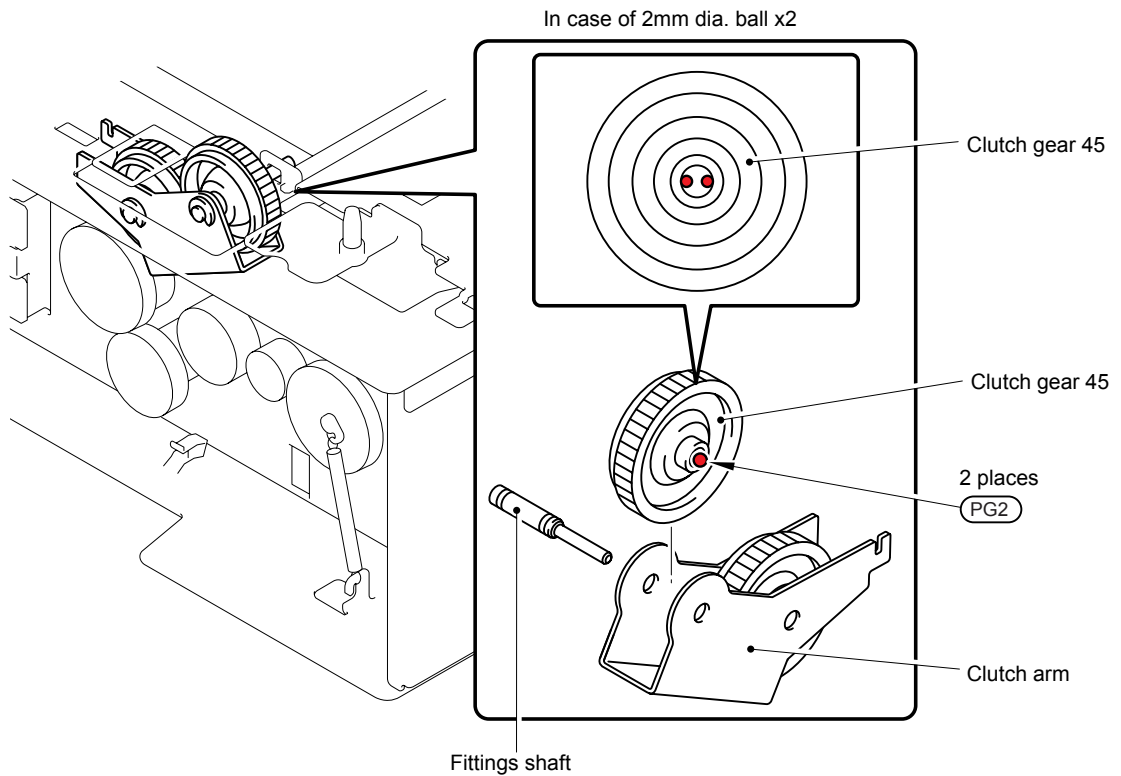

PG2: PG-661(W) (2mm dia. ball)

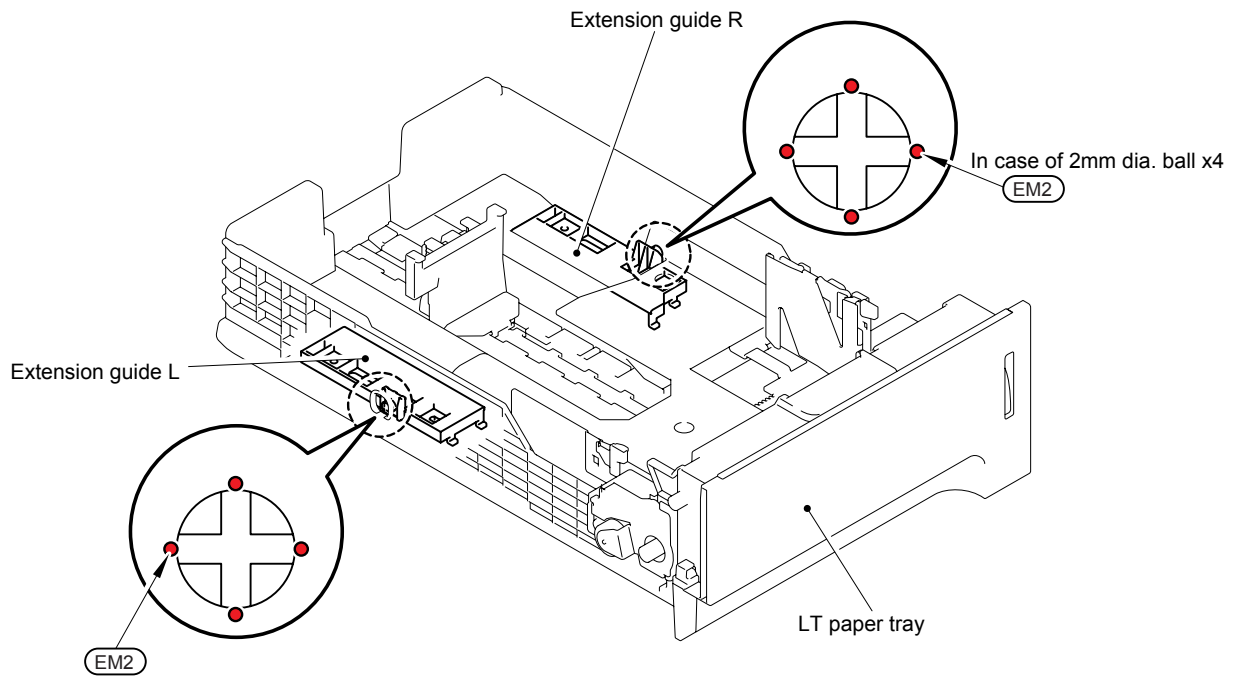

EM2: MOLYKOTE EM-D110 (2mm dia. ball)

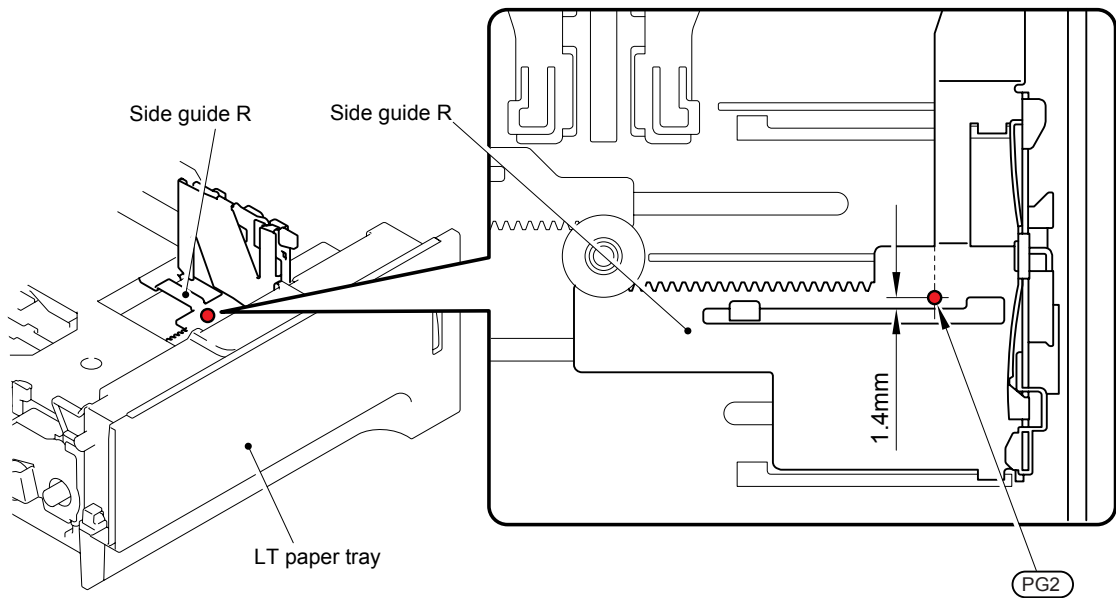

PG2: PG-661(W) (2mm dia. ball)

5. OVERVIEW OF GEARS

■ DEVELOPER DRIVE

<Development view>

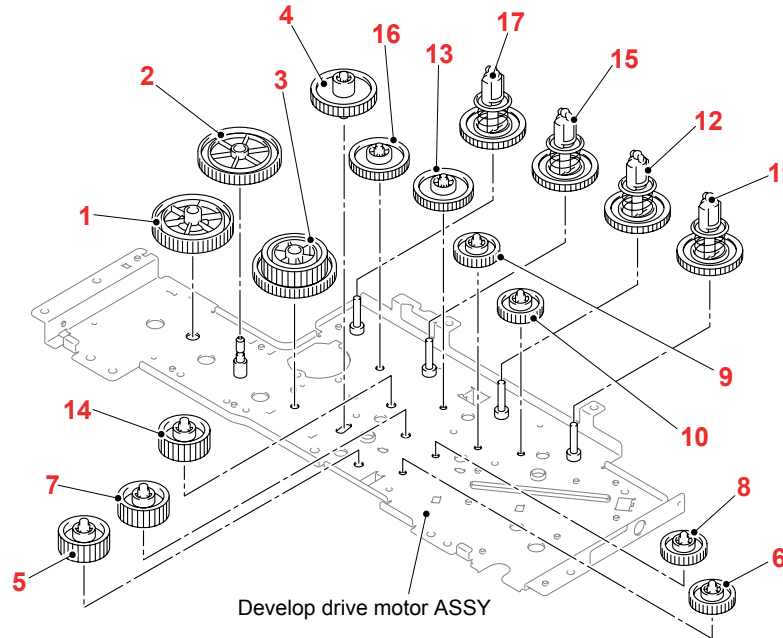

<Layout view>

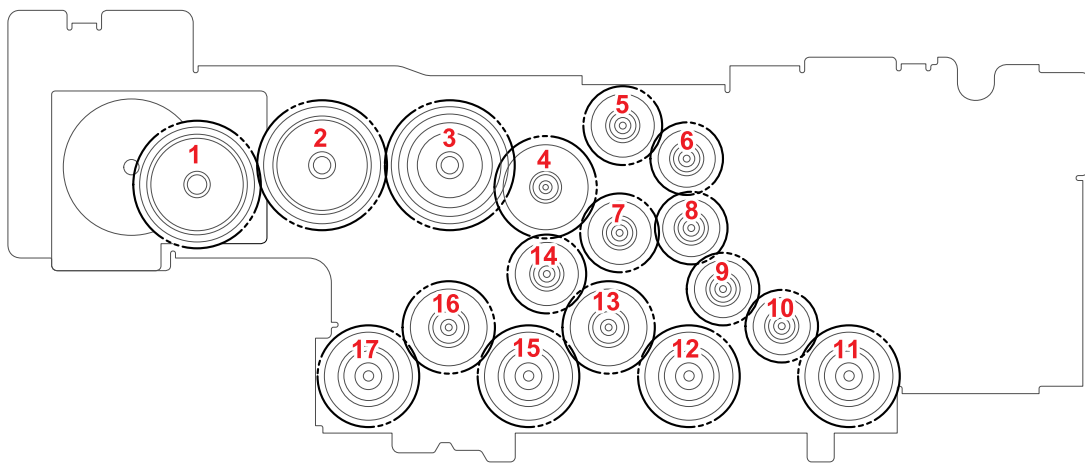

<Name of Gears>

1	LR0194001	Gear 98	10	LR0199001	Gear 35
2	LR0202001	Gear 100	11	LR0203001	Coupling gear 50
3	LR0201001	Gear 50/100	12	LR0203001	Coupling gear 50
4	LR0197001	Pendulum gear 50	13	LR0200001	Gear 45
5	LR0198001	Gear 38	14	LR0198001	Gear 38
6	LR0199001	Gear 35	15	LR0203001	Coupling gear 50
7	LR0198001	Gear 38	16	LR0200001	Gear 45
8	LR0199001	Gear 35	17	LR0203001	Coupling gear 50
9	LR0199001	Gear 35			

* These parts are subject to change without notice.

■ PAPER EJECT (1/2)

<Development view>

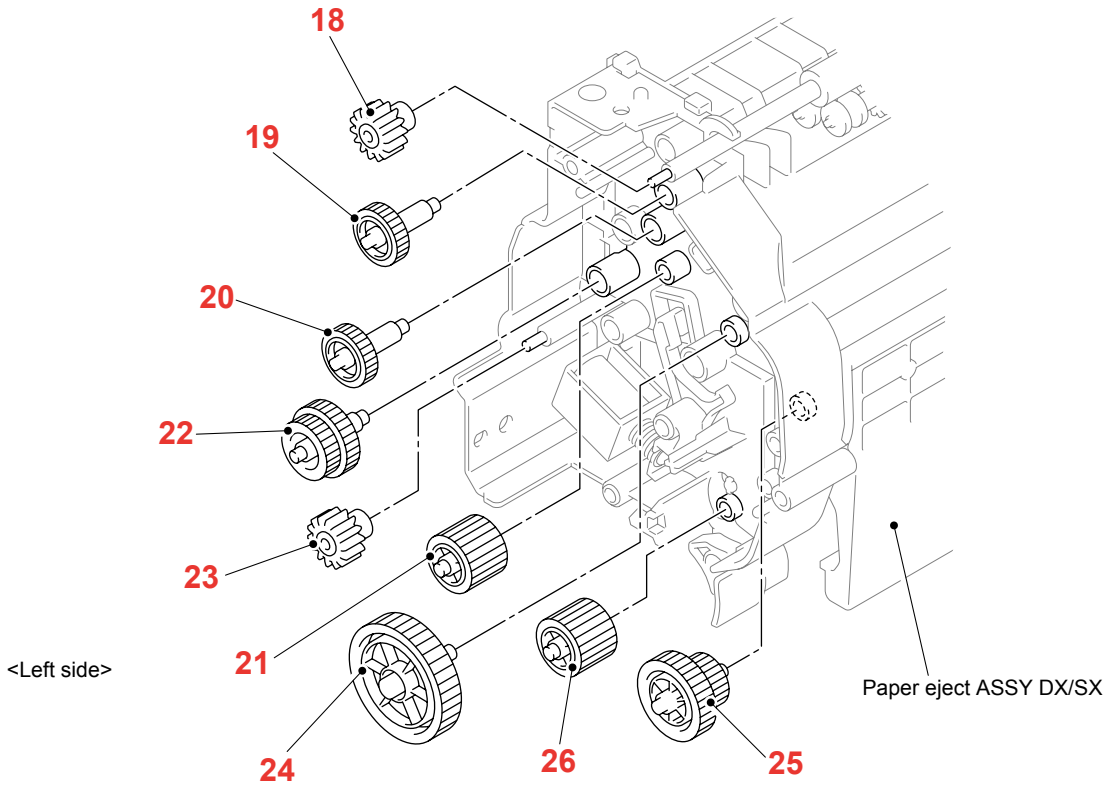

<Layout view>

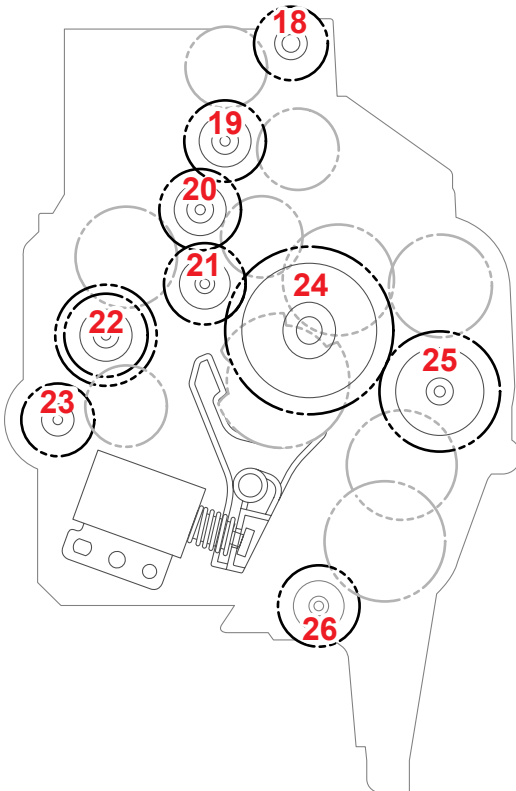

<Name of Gears>

18	LR0482001	Eject roller gear
19	LJ7365001	Idle gear 16B
20	LJ7365001	Idle gear 16B
21	LM5016001	Ejector gear 16
22	LR0480001	Ejector gear 16/20
23	LR0482001	Eject roller gear
24	LR1181001	Ejector gear 36 SX
25	LR0478001	Ejector gear 14/24
26	LM5016001	Ejector gear 16

* These parts are subject to change without notice.

■ PAPER EJECT (2/2)

<Development view>

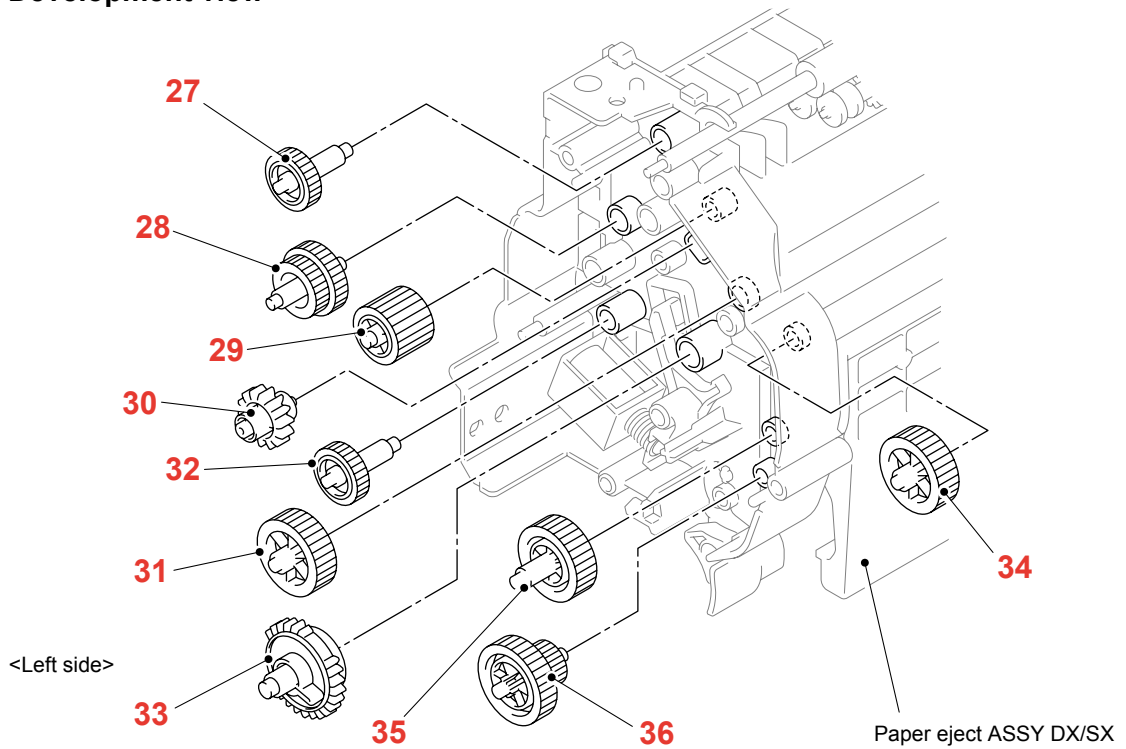

<Layout view>

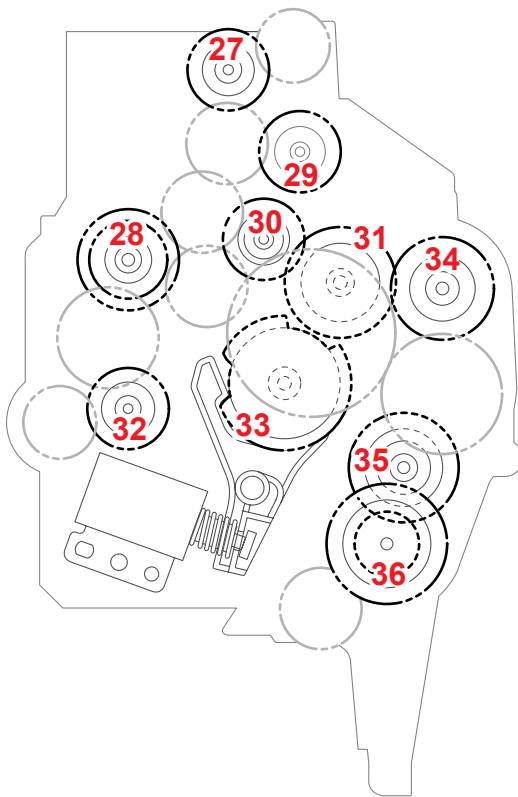

<Name of Gears>

27	LJ7365001	Idle gear 16B
28	LR0479001	Ejector gear 15/20
29	LM5016001	Ejector gear 16
30	LM5018001	Ejector gear 16 planetary
31	LM5019001	Ejector gear 22
32	LJ7365001	Idle gear 16B
33	LR0979001	Ejector gear 28 sector
34	LM5019001	Ejector gear 22
35	LR0476001	Ejector gear 22B
36	LR0477001	Ejector gear 12/24

* These parts are subject to change without notice.

■ PF DRIVE

<Development view>

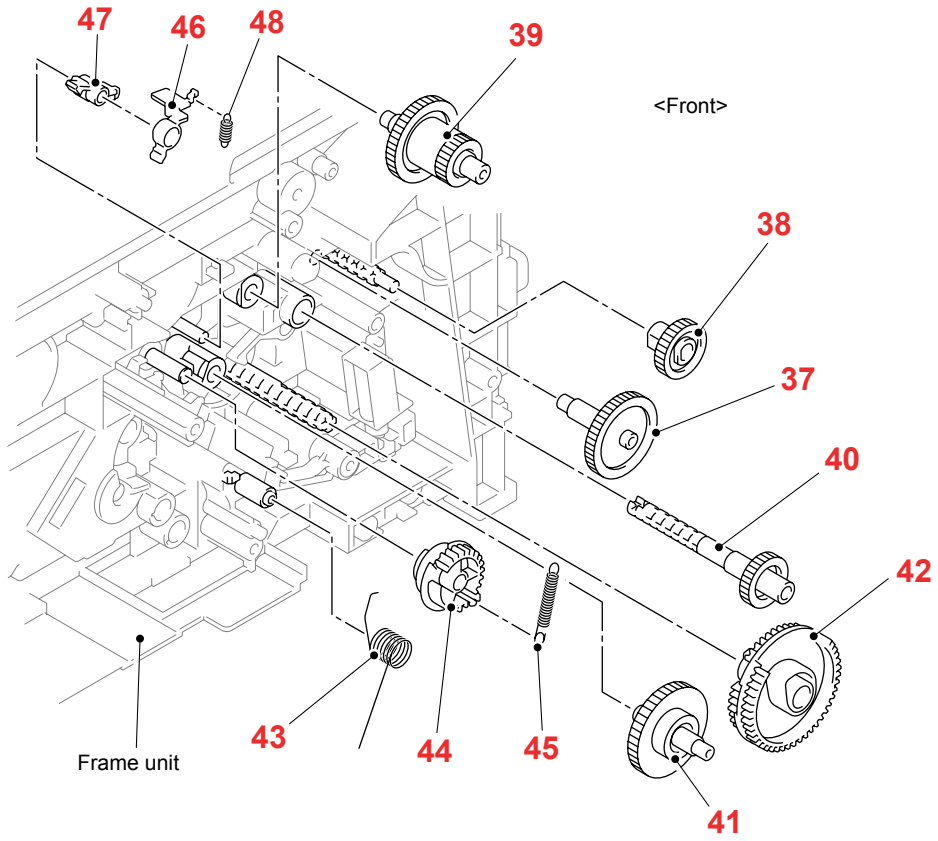

<Layout view>

Location of PF drive gears

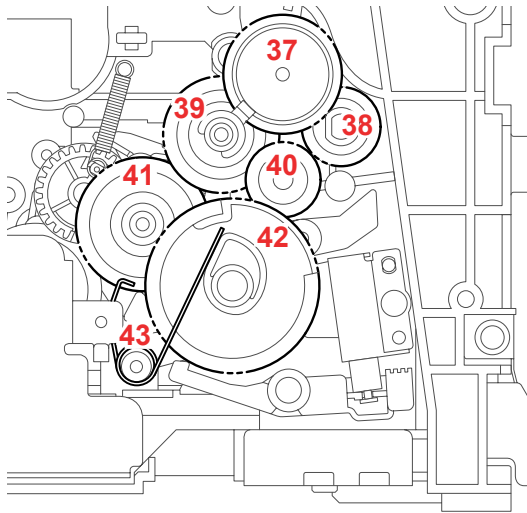

<Name of Gears>

37	LR0316001	Gear Z35M75
38	LR0311001	PF drive gear Z23M75
39	LR0315001	Gear Z3218M0875
40	LR0326001	PU drive gear Z20M08
41	LR0314001	Gear Z3717M08
42	LR0320001	PU sector gear Z4648M08
43	LR0324001	Torque spring for PU sector

Location of parts after removing the parts shown as 37 to 43 in the figure above

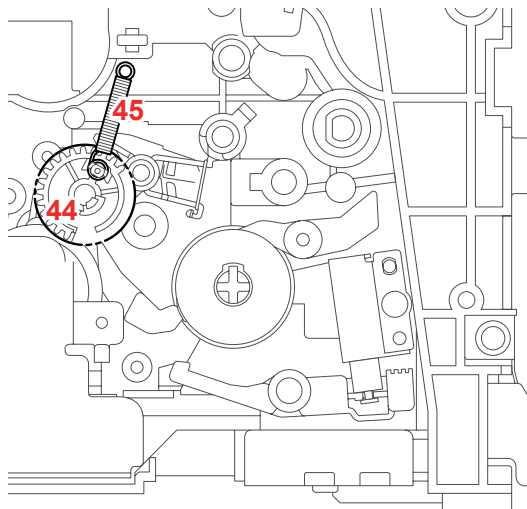

<Name of Gears>

44	LR0309001	PP gear clutch cam
45	LR0310001	PP gear clutch cam spring

Location of parts after removing the parts shown as 44 and 45 in the figure above

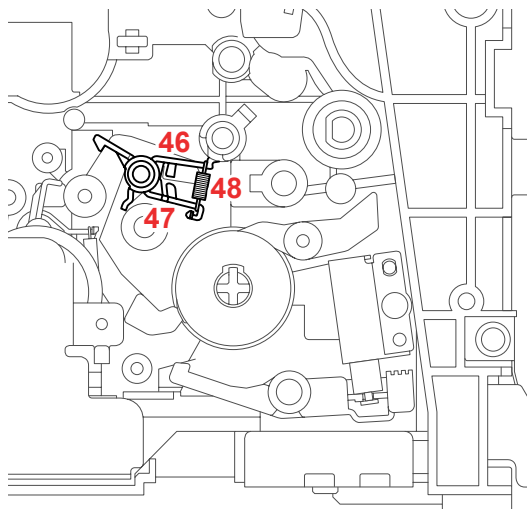

<Name of Gears>

46	LR0308001	Hook C
47	LR0307001	Hook B
48	LR0910001	Hook spring BC

* These parts are subject to change without notice.

6. HARNESS ROUTING

1

Transfer HVPS PCB unit (Registration-mark sensor PCB ASSY 1, 2, Density sensor)

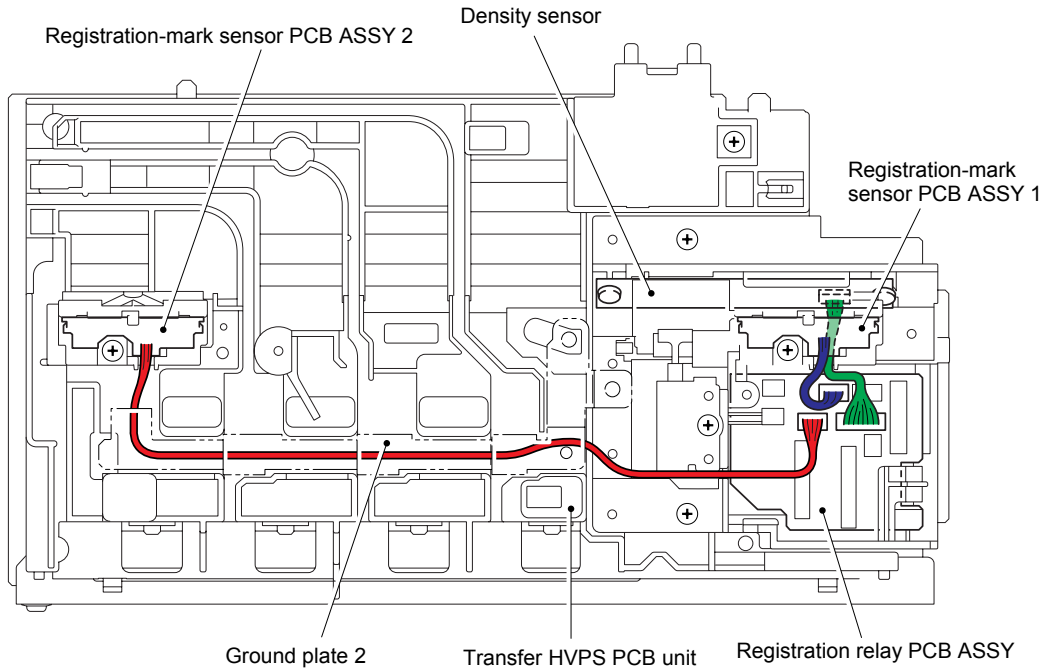

2

USB host relay PCB ASSY (MFC-9440CN/ 9450CDN only)

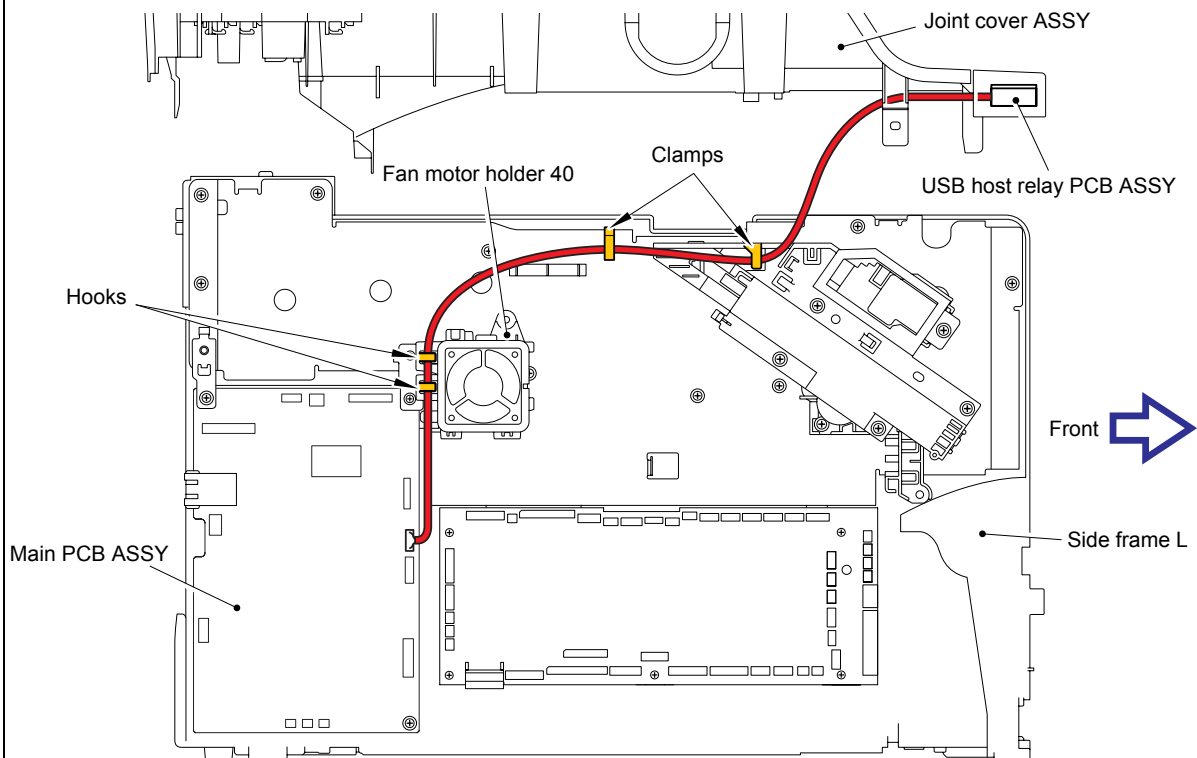

3 T1 PE/edge sensor PCB ASSY, Belt cleaner release sensor PCB ASSY

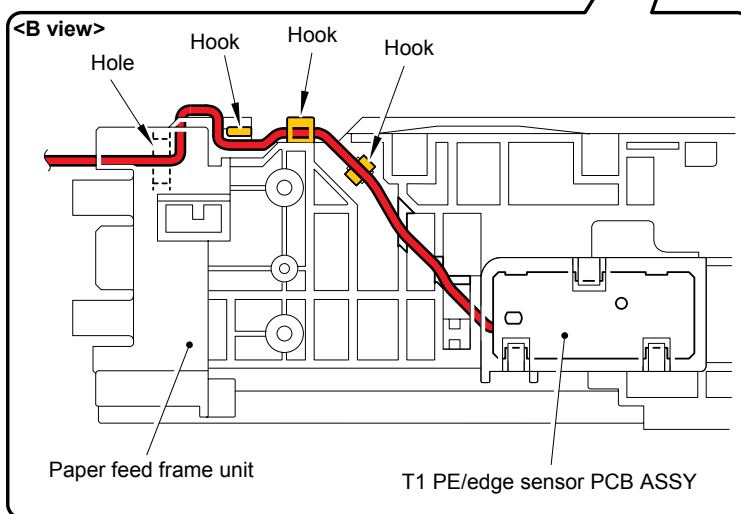
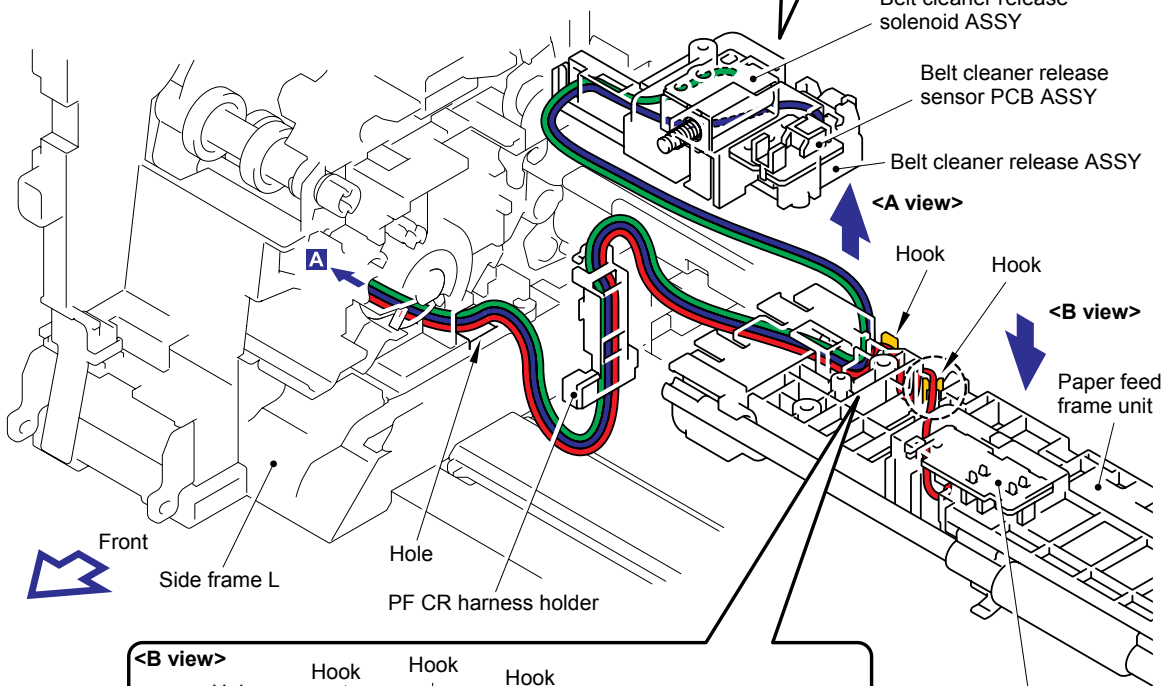
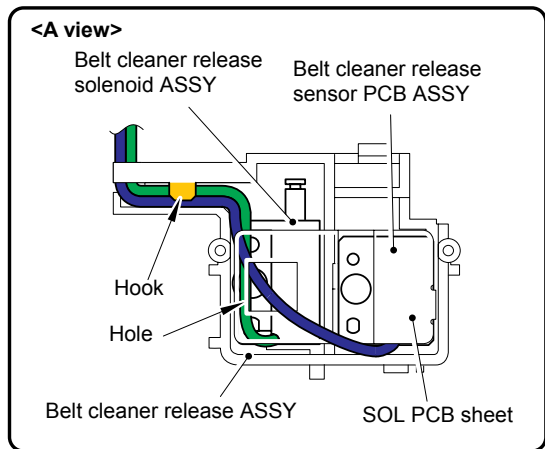
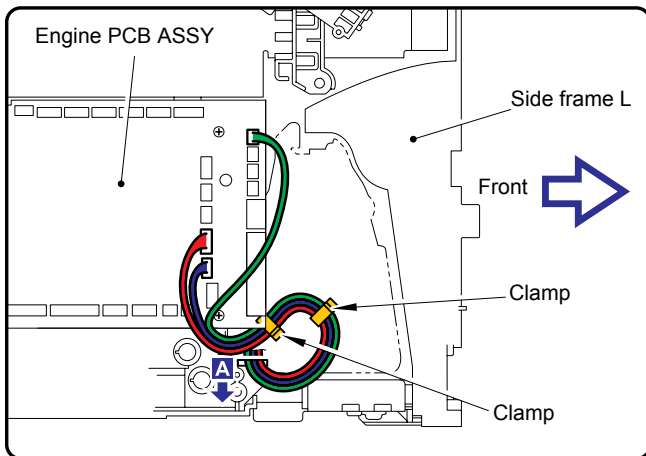

T1 PE/edge sensor PCB ASSY

4 Develop release sensor PCB ASSY

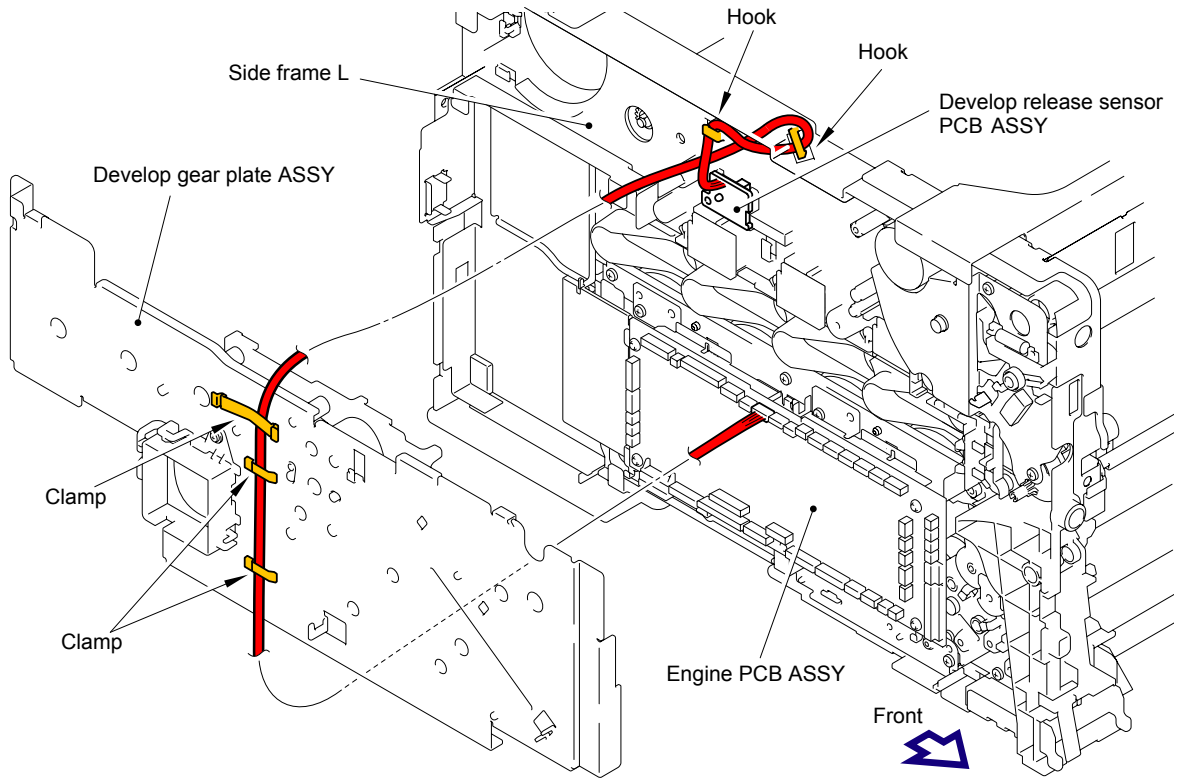

5 Toner sensor PCB ASSY K, Y, M, C (TE/NEW)

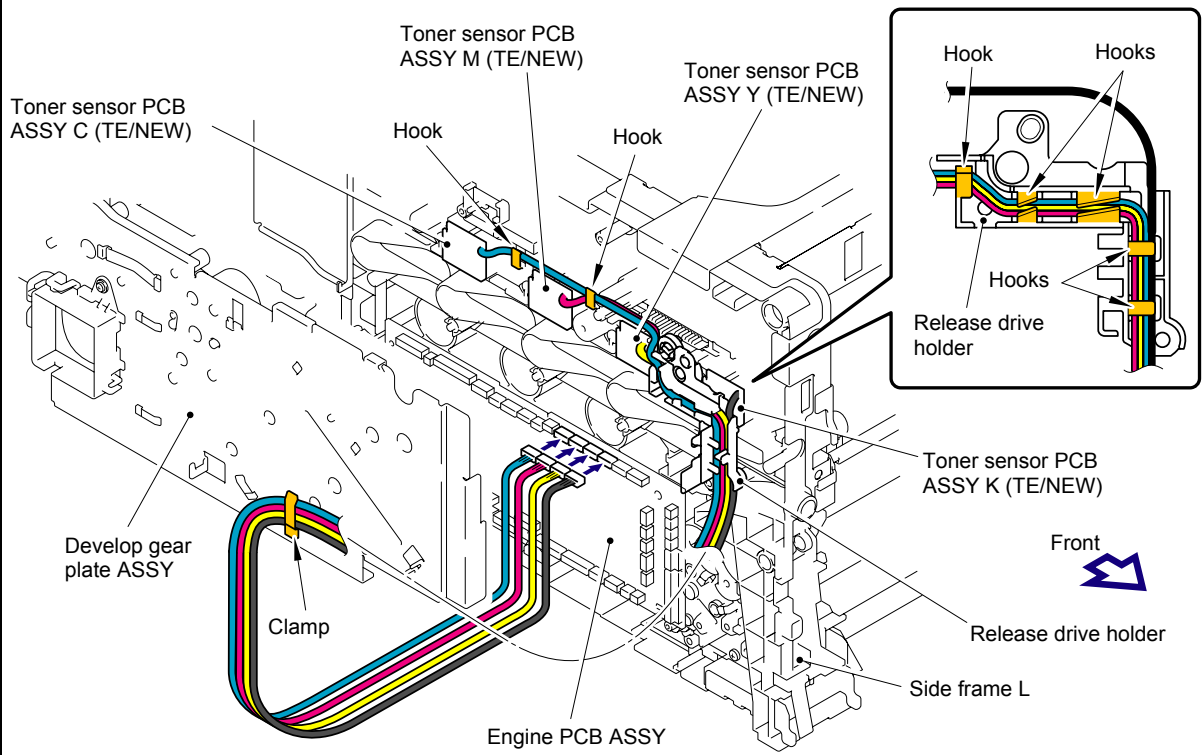

6 Laser unit

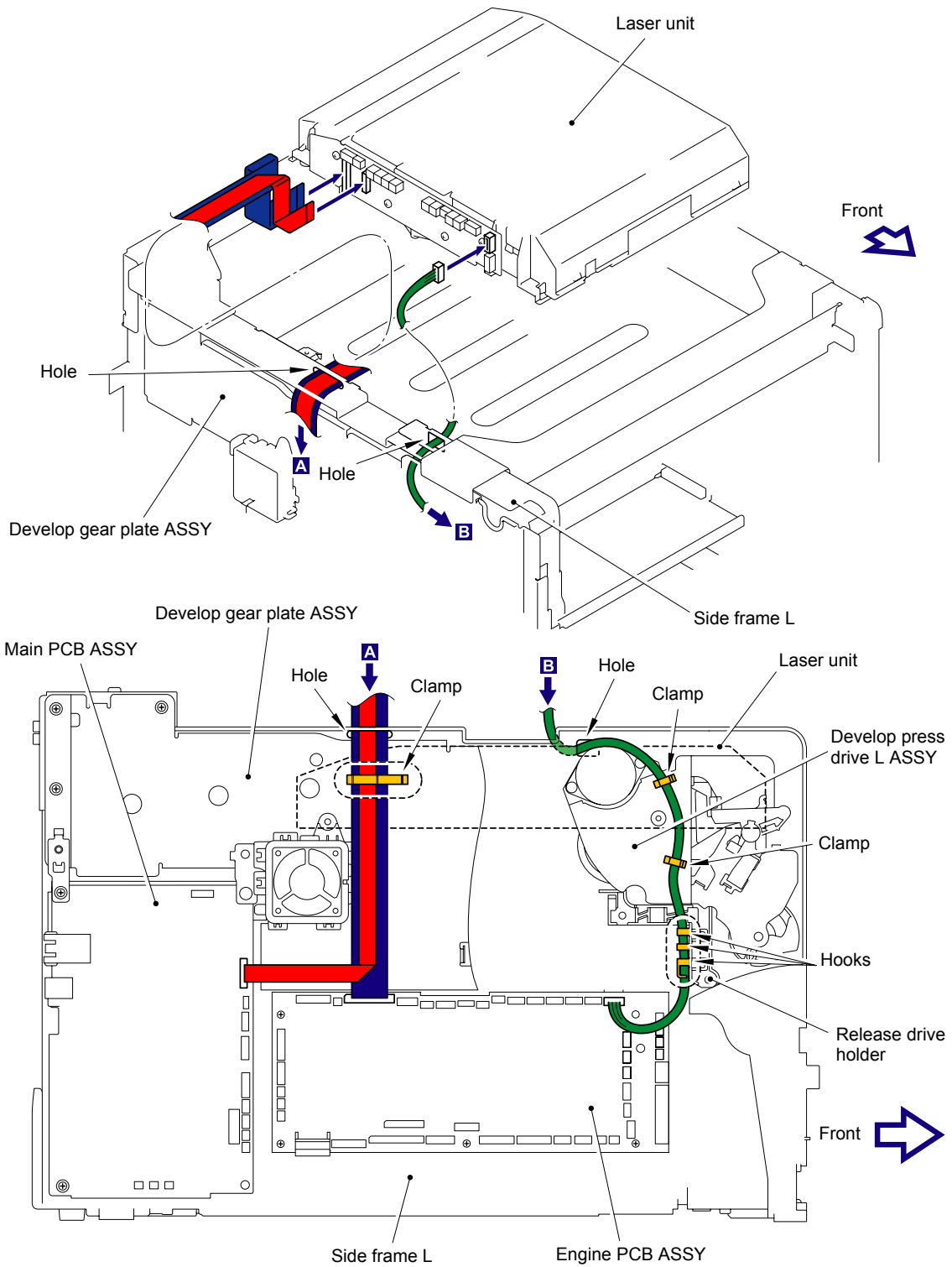

7

**Develop press drive L ASSY
(Develop release motor ASSY, Front cover interlock switch ASSY)**

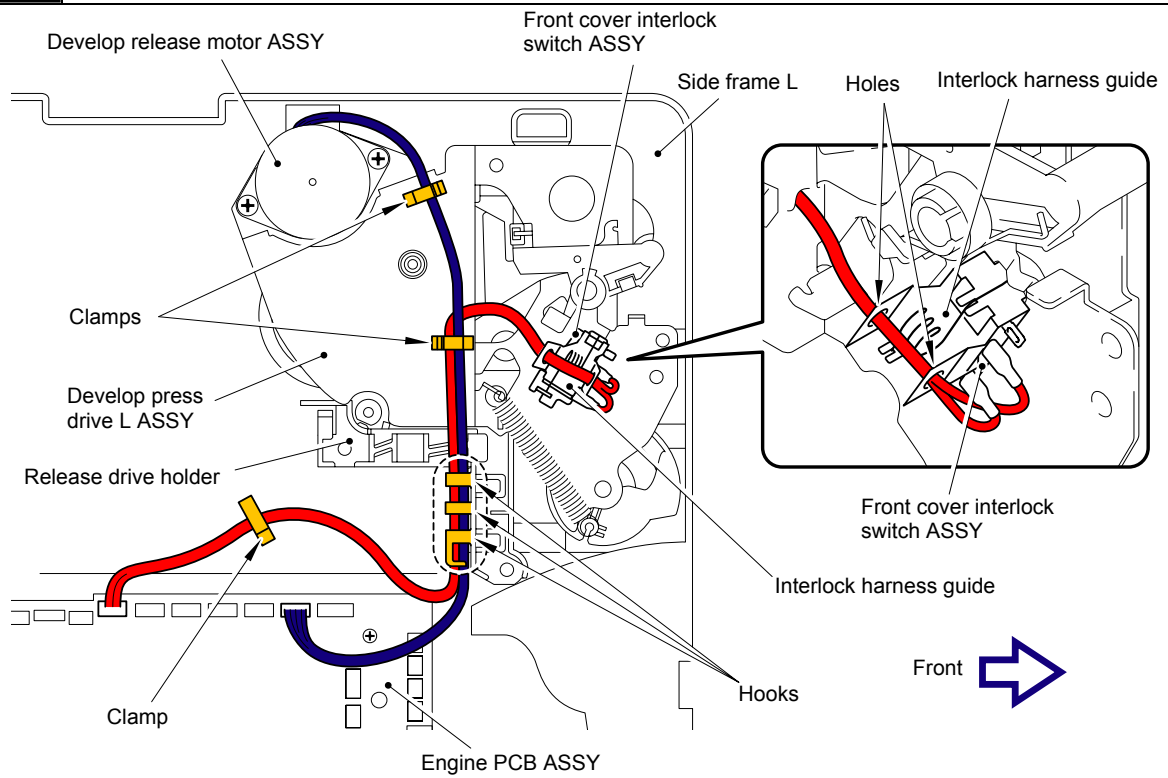

8

LVPS fan (PS)

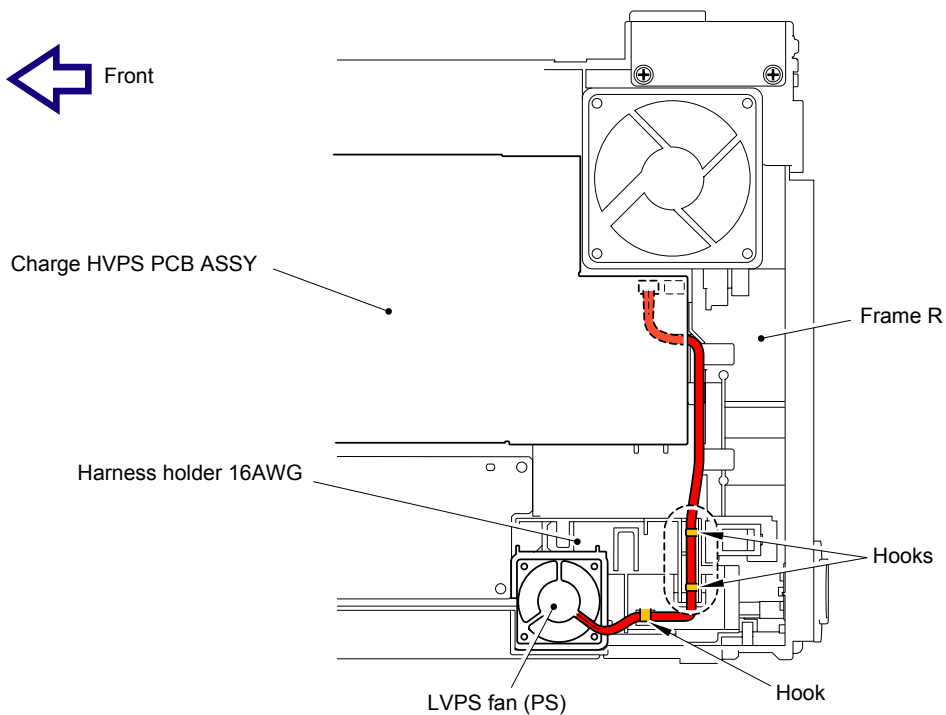

9

PS PCB unit

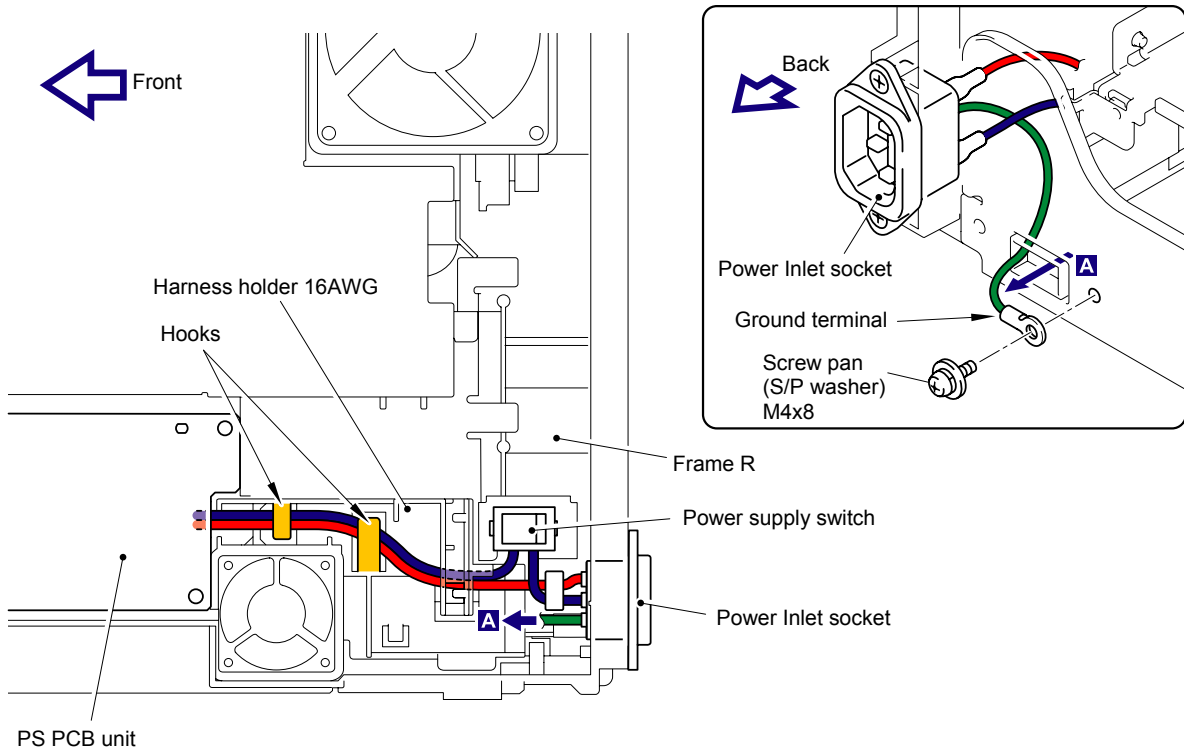

10

NCU unit (MFC-9440CN/ 9450CDN only)

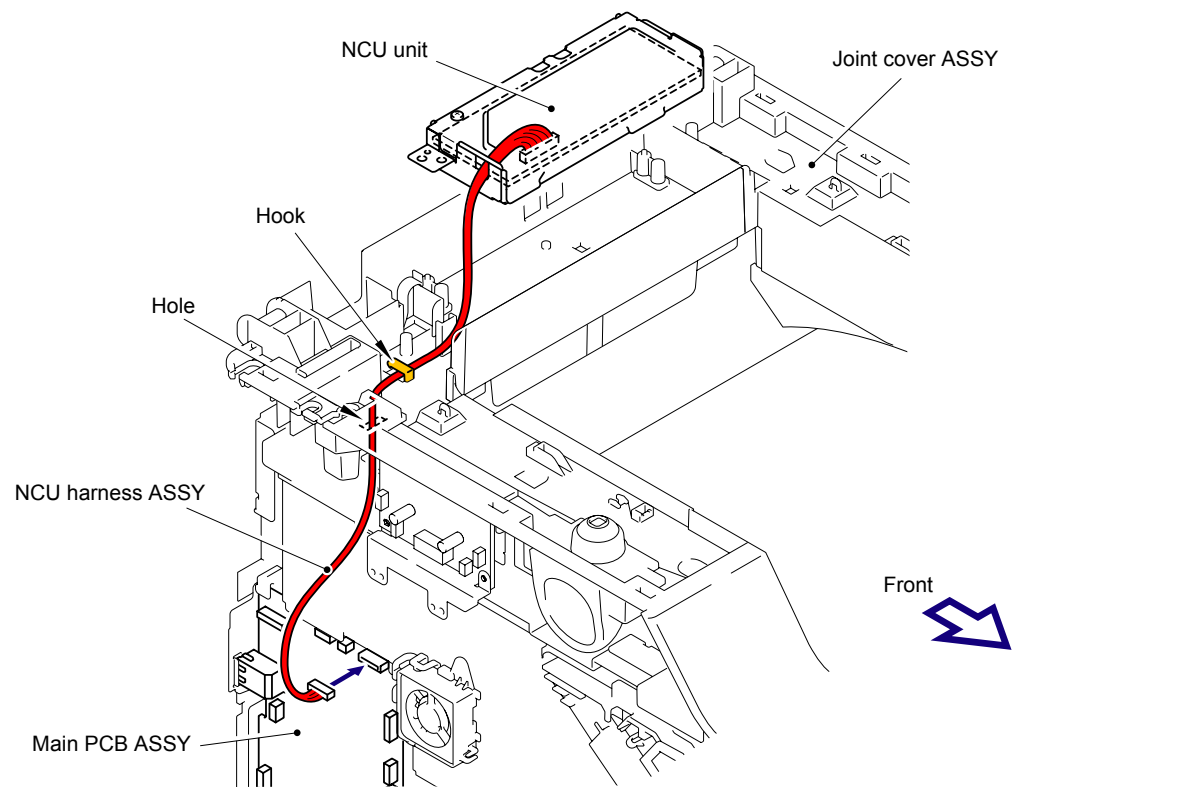

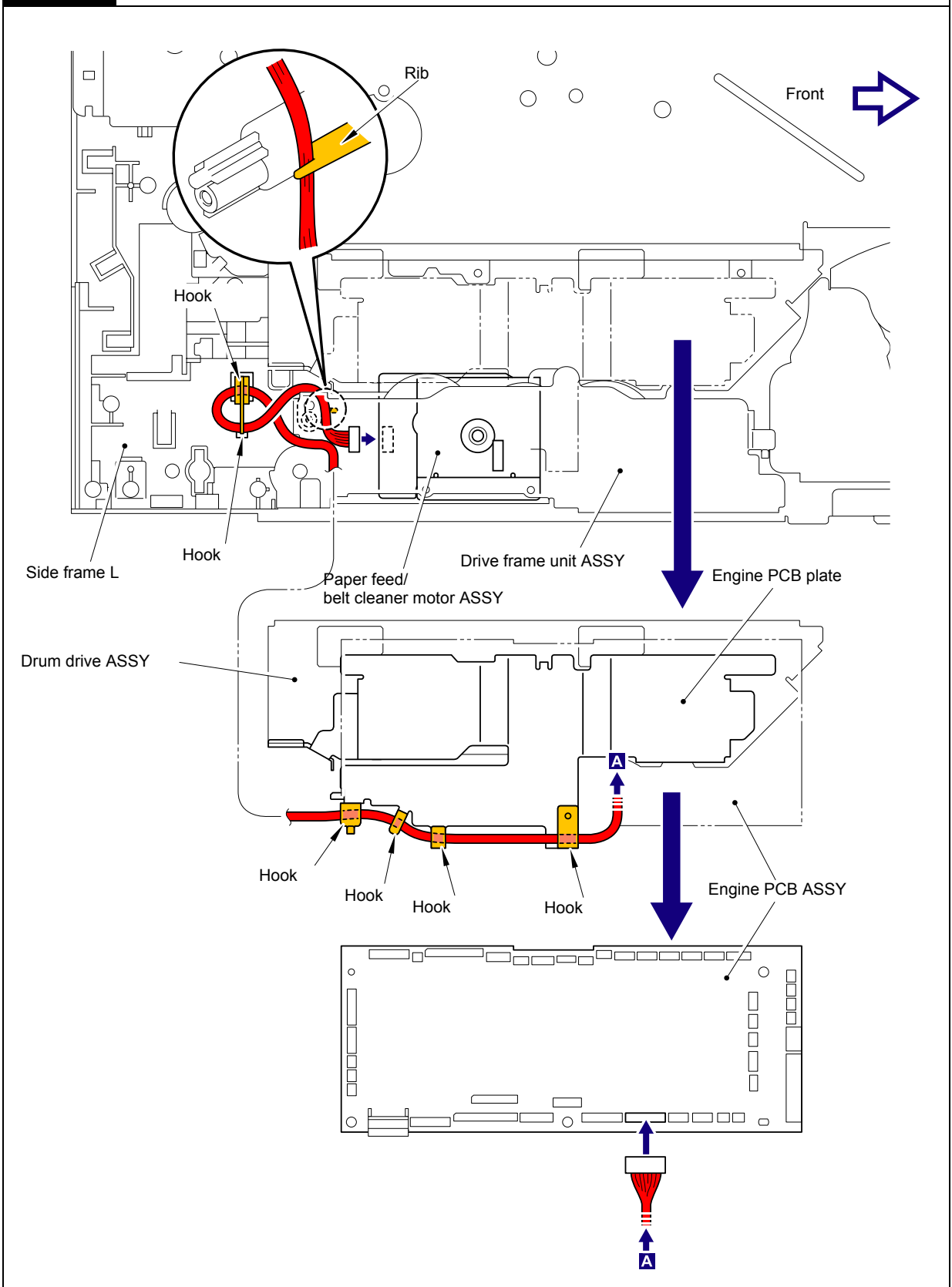

12

ADF unit

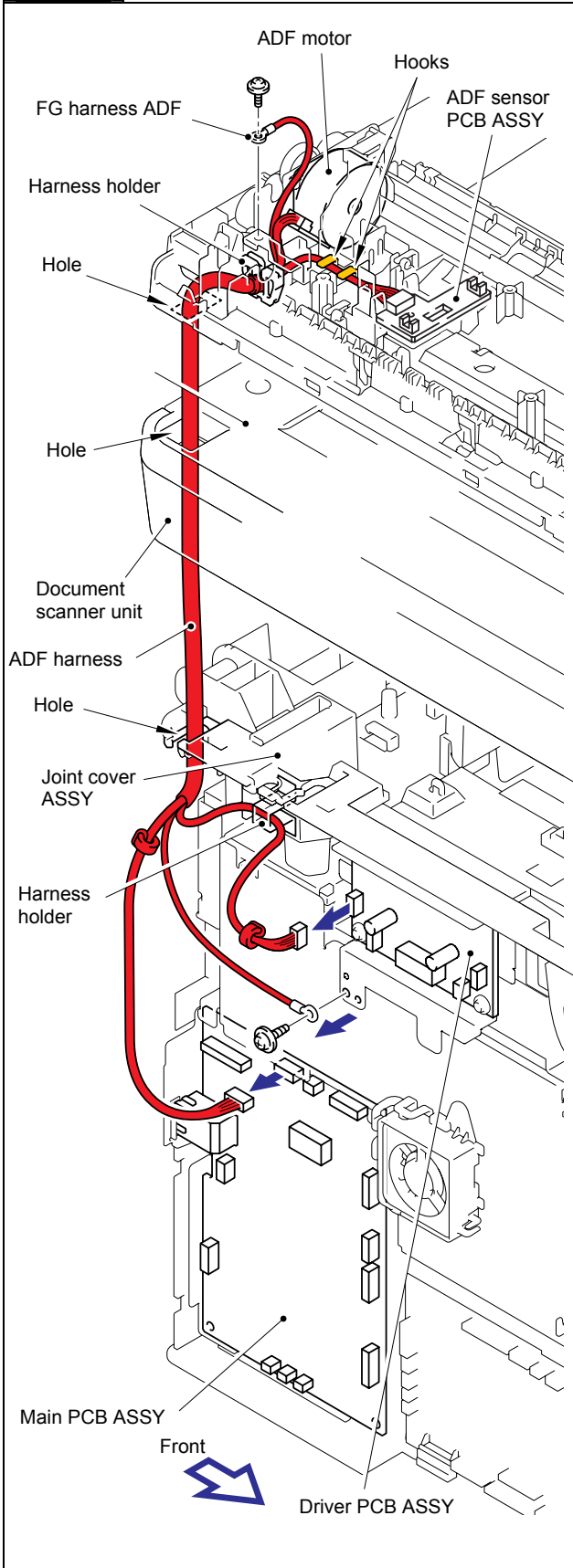

13

Document scanner unit

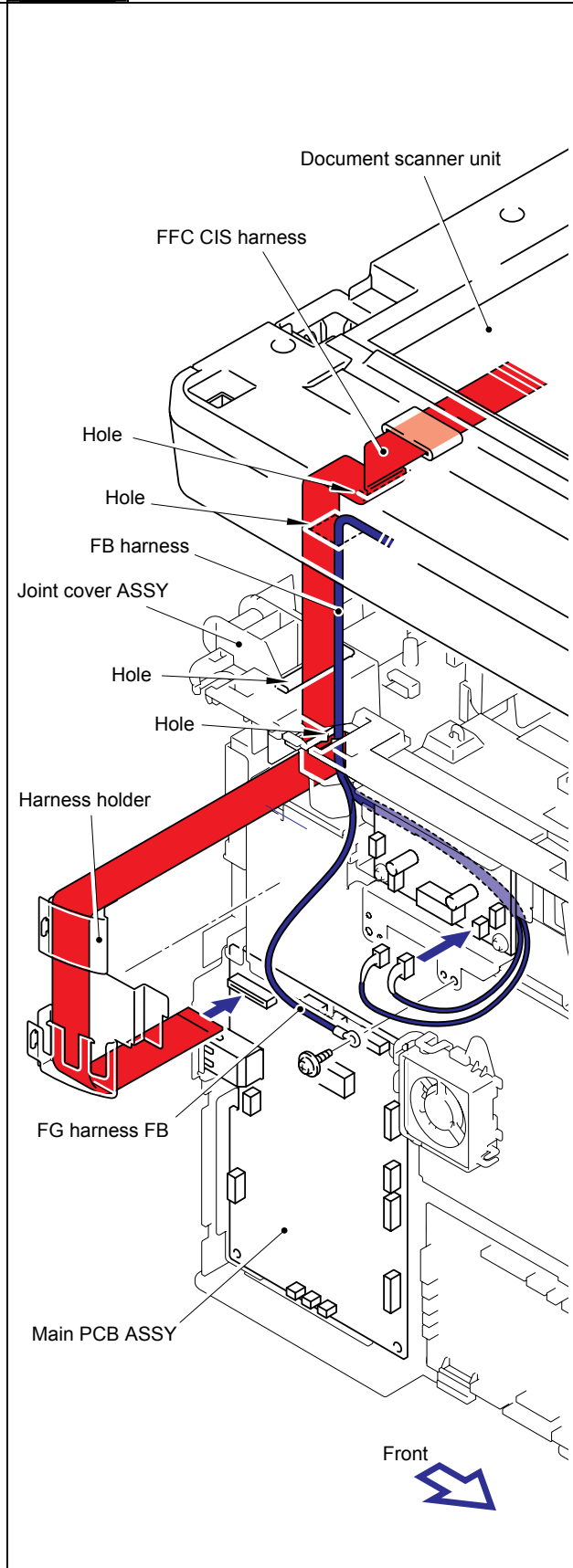

14 Panel unit

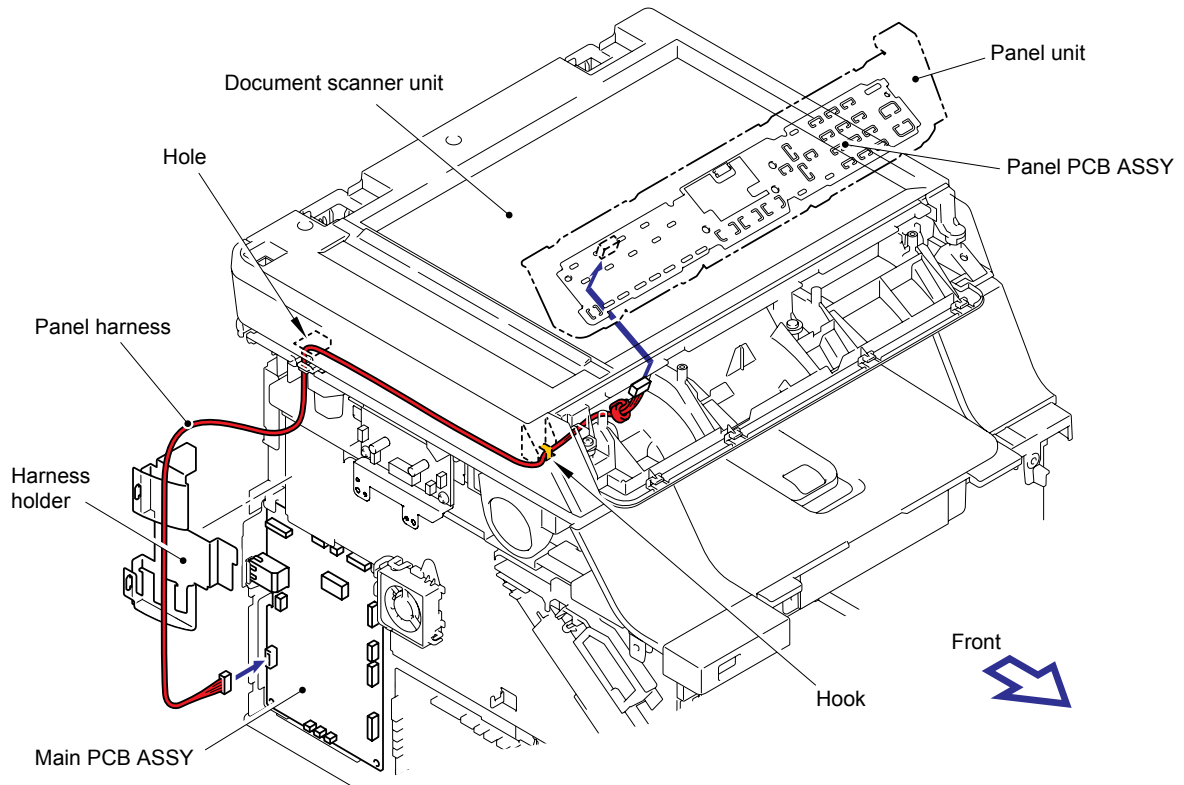

15 Speaker ASSY

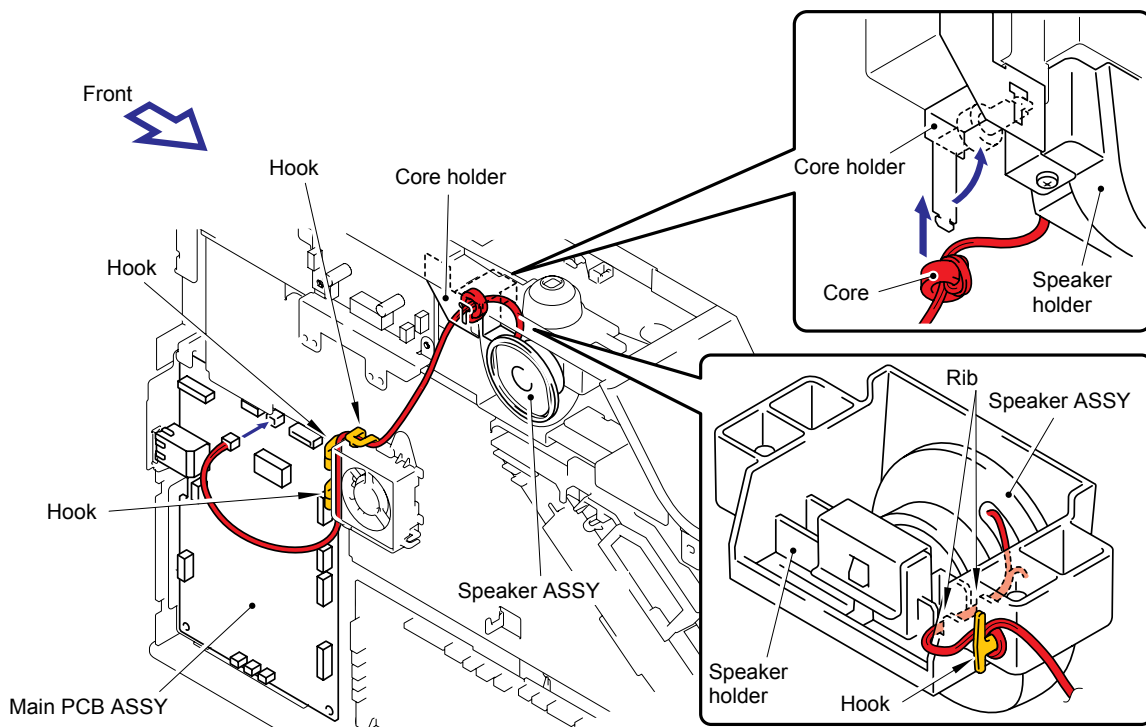

■ Preparation

Prior to proceeding with the disassembly procedure,

(1) Unplug

- the AC cord,
- the modular jack of the telephone line,
- the USB cable, if connected,
- the LAN cable, if connected,
- the USB cable for PictBridge, if connected, and
- the modular jack of the external telephone set if connected.

(2) Remove

- the Paper tray,
- the Toner cartridge x 4,
- the Drum unit,
- the Belt unit, and
- the Waste toner box.

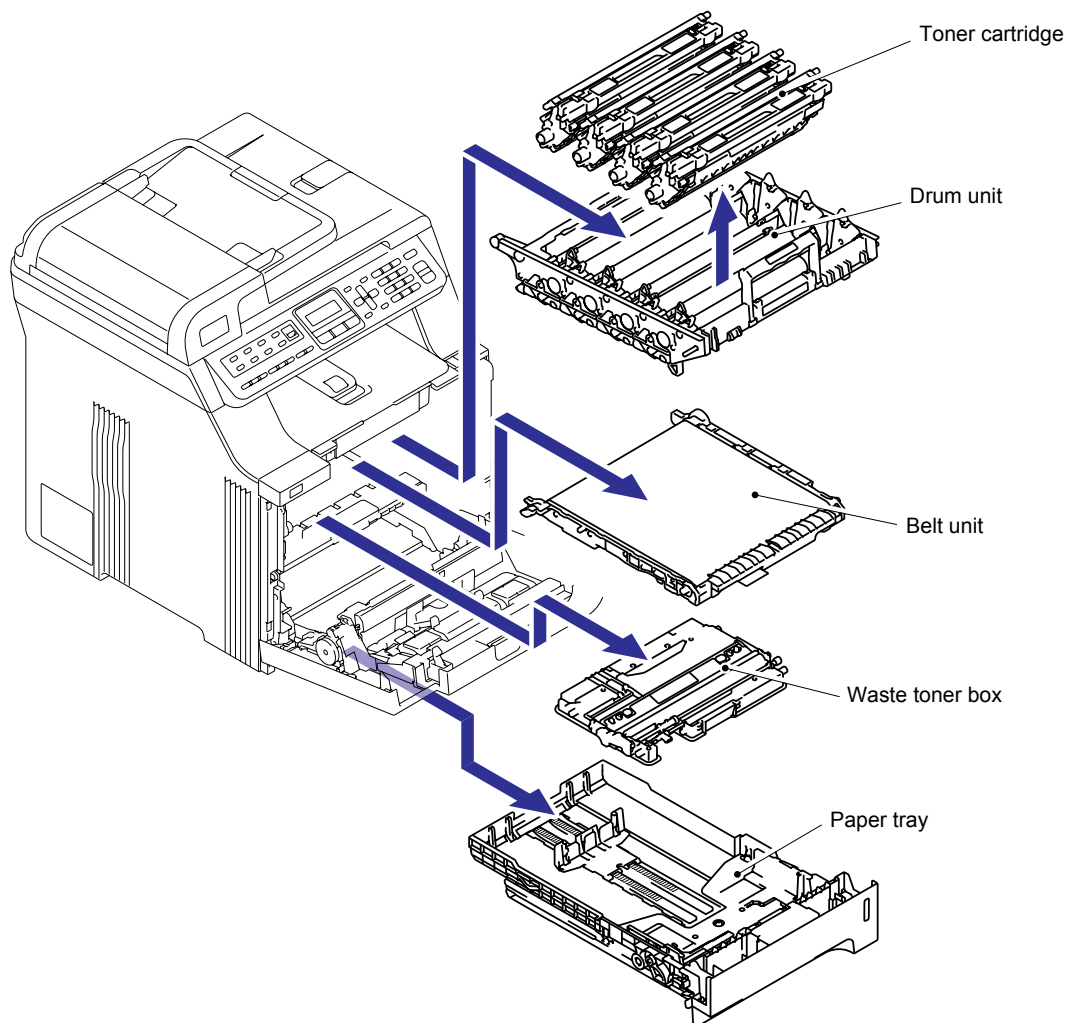

7. DISASSEMBLY FLOW

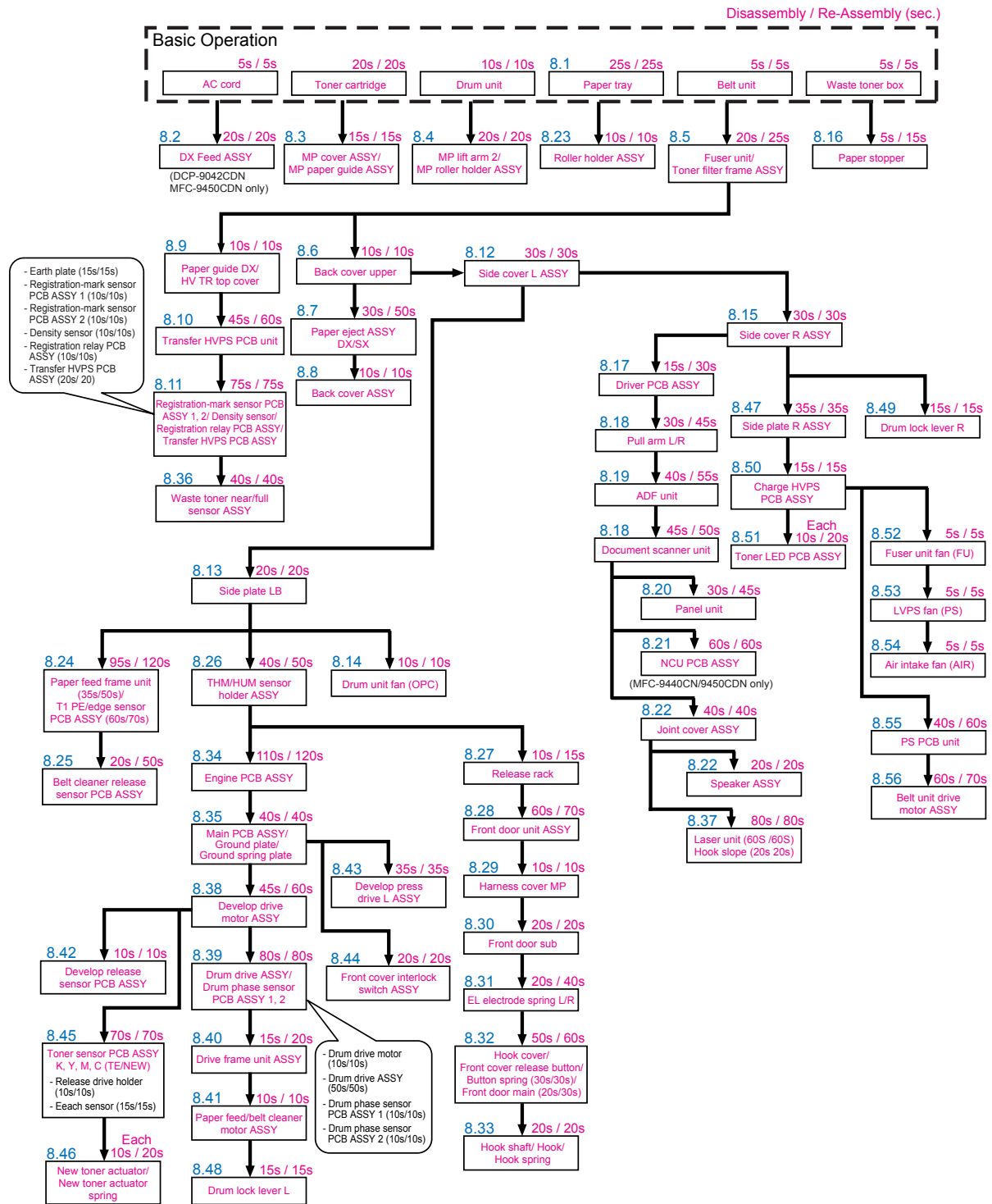

8. DISASSEMBLY PROCEDURE

8.1 Paper Tray

- (1) Release the two Hooks of the Separation pad ASSY, and then lift up the Separation pad ASSY.

Note:

Be careful not to loose the Separation pad spring.

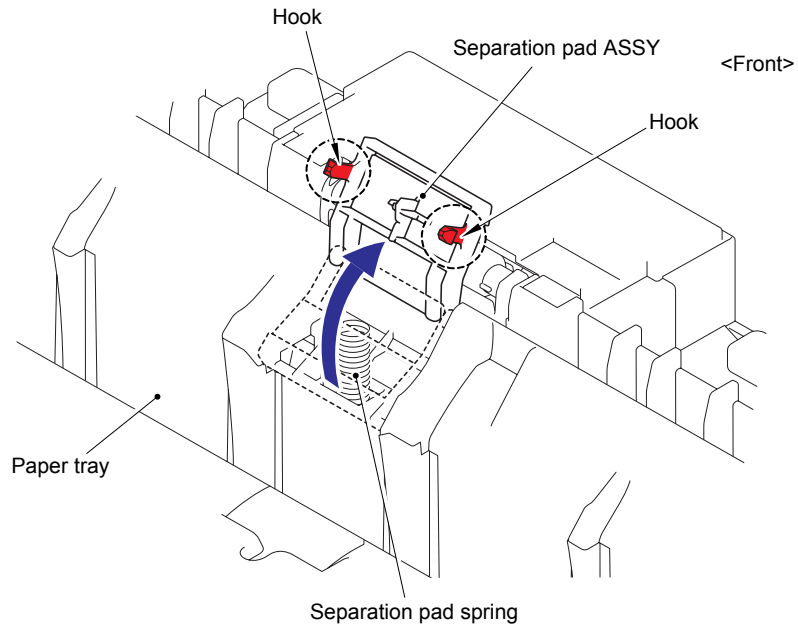

Fig. 3-1

- (2) Push both sides of the Separation pad ASSY inwards to release the Pins and remove the Separation pad ASSY from the Paper tray.
- (3) Remove the Separation pad spring from the Paper tray.

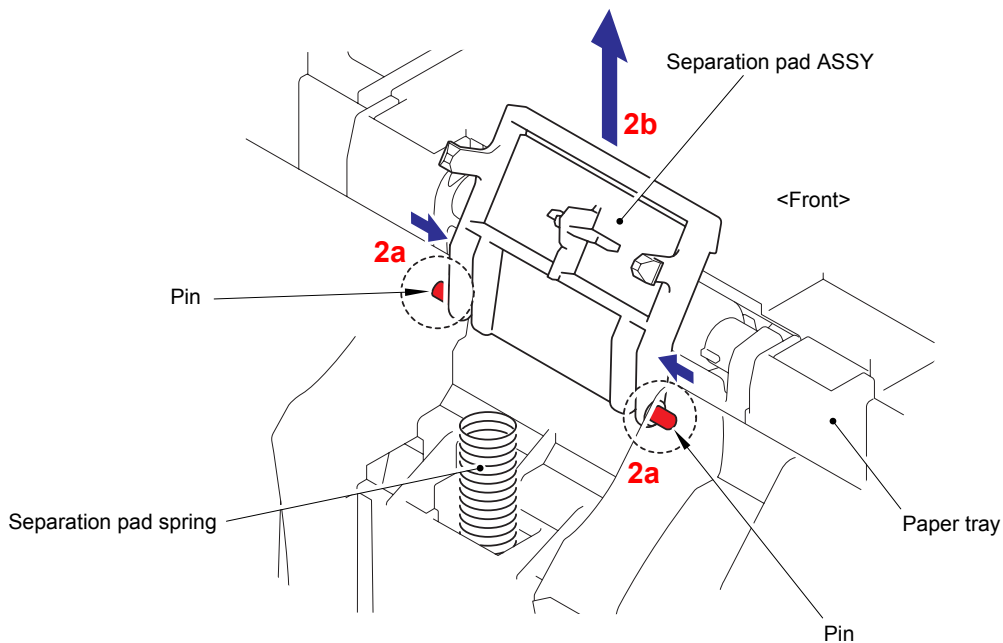

Fig. 3-2

The following procedure is for DCP-9042CDN and MFC-9450CDN only.

- (4) Remove the two bind B M4x12 Taptite screws, and then remove the Tray cover ASSY.

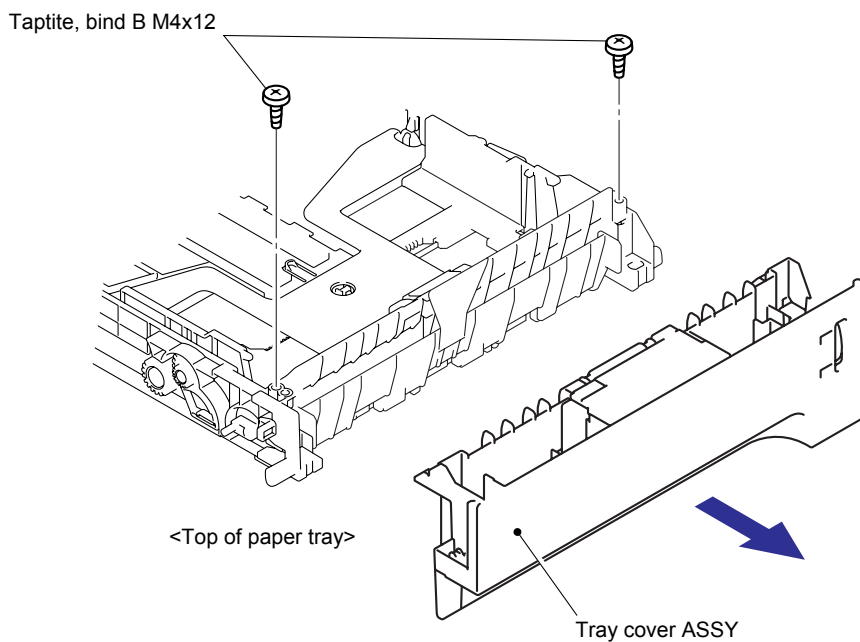

Fig. 3-3

- (5) Turn the paper tray upside down.
- (6) Release the two Hooks to remove the Paper guide DX ASSY.

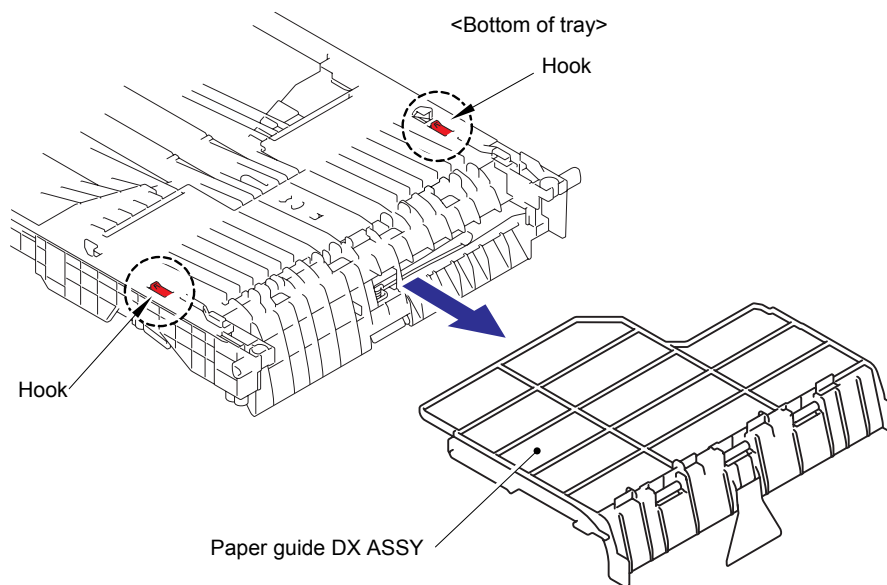

Fig. 3-4

8.2 DX feed ASSY (DCP-9042CDN/ MFC-9450CDN only)

- (1) Release the three Hooks to remove the DX hook ASSY.
- (2) Release the two Bosses to remove the DX feed ASSY.

* Release the boss on the right hand side first.

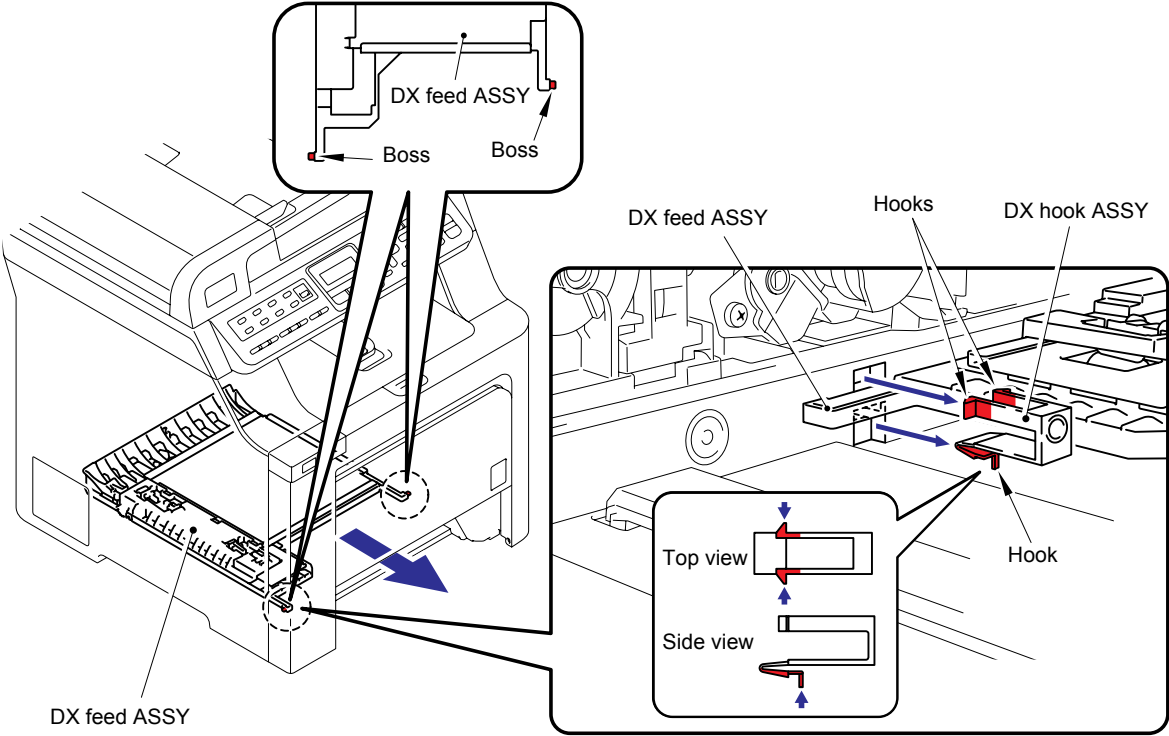

Fig. 3-5

8.3 MP Cover ASSY/ MP Paper Guide ASSY

(1) Open the MP cover ASSY.

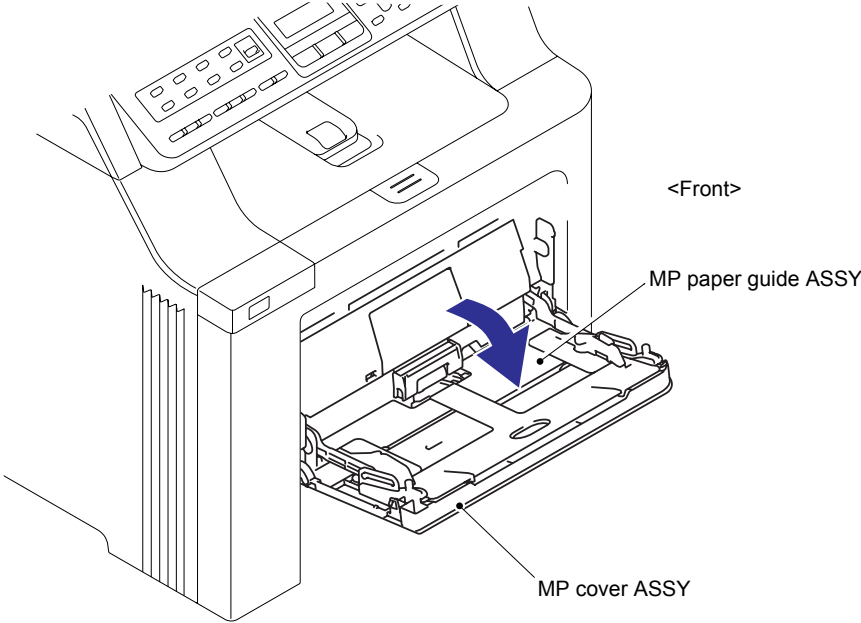

Fig. 3-6

(2) Release the two Bosses of the MP paper guide ASSY.

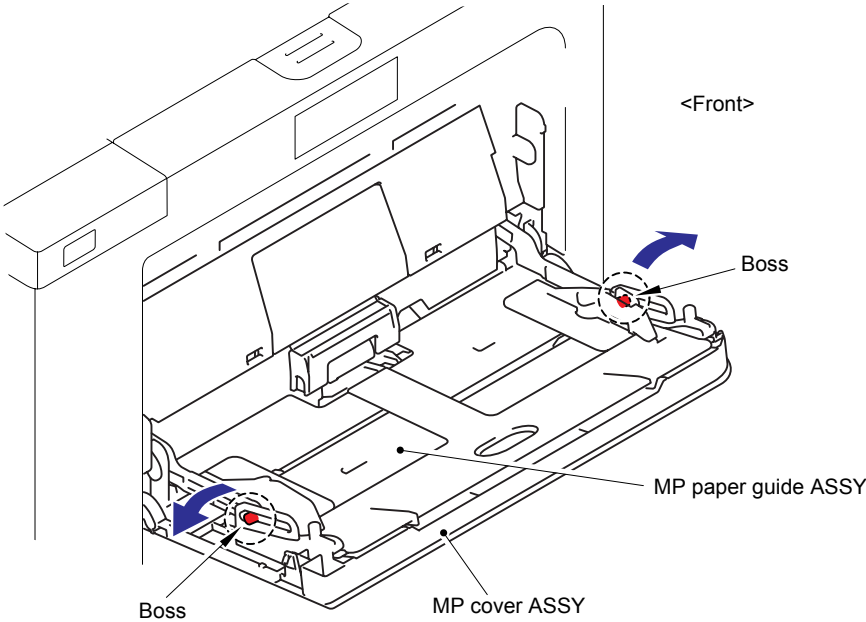

Fig. 3-7

- (3) Lift up the MP paper guide ASSY align the MP paper guide ASSY with section "A" of the MP lower chute. Bend section "A" then, remove the MP paper guide ASSY.

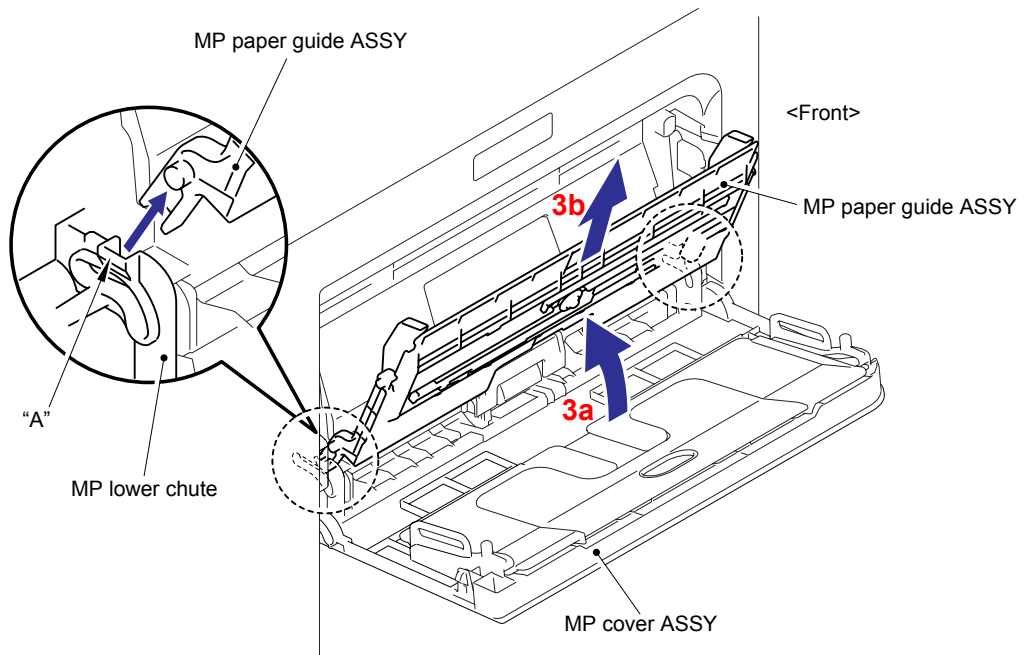

Fig. 3-8

- (4) Release the Bosses while bending the MP cover ASSY and remove the MP cover ASSY from the Front door main.

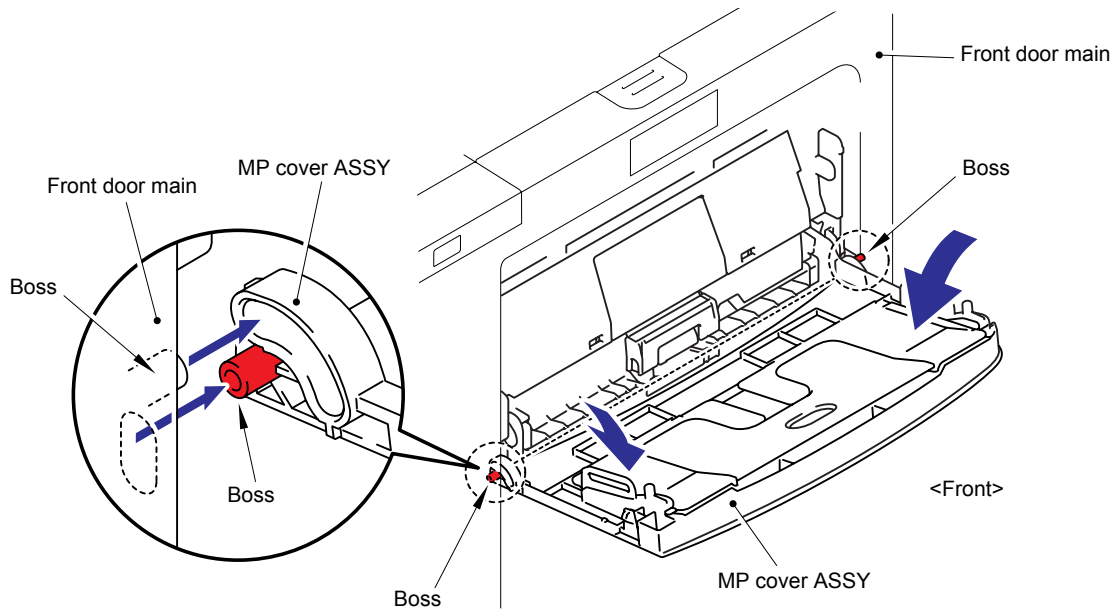

Fig. 3-9

Assembling Note:

When assembling the MP paper guide ASSY, note the assembling method referring to the figure below.

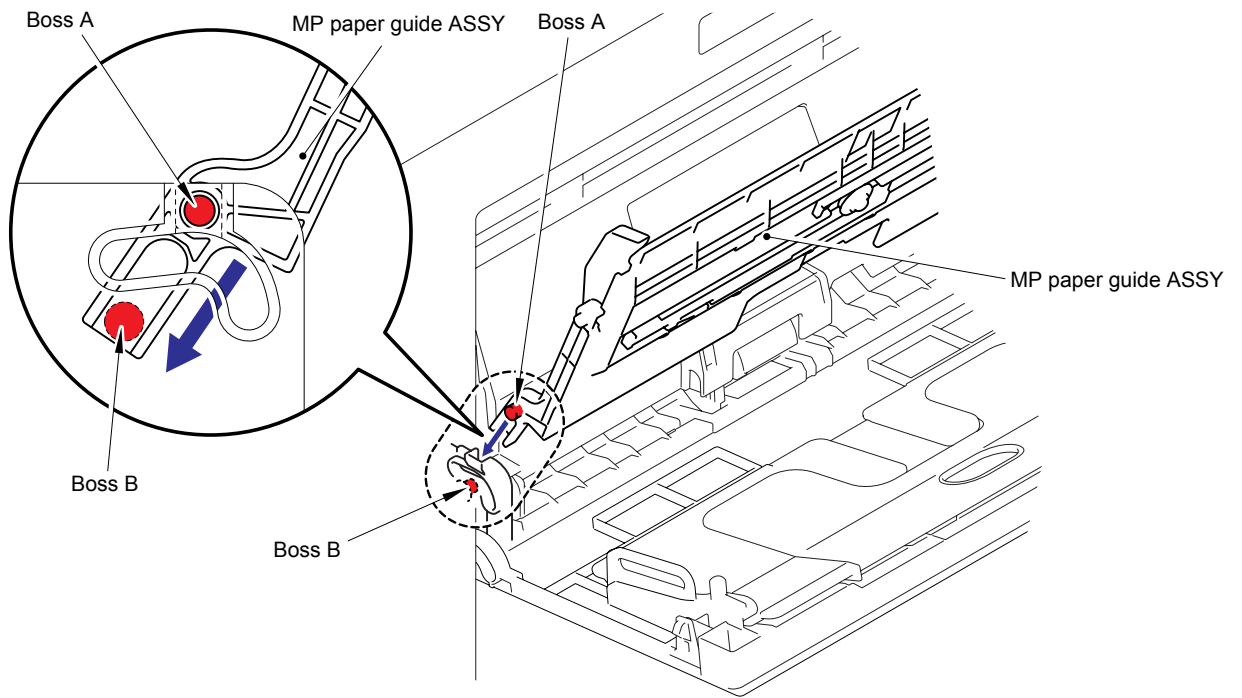

Fig. 3-10

8.4 MP Lift Arm 2/ MP Roller Holder ASSY

- (1) Press the Front cover release button, and open the Front door unit ASSY.
- (2) Release the two Hooks to remove the MP feed frame cover from the Front door unit ASSY.

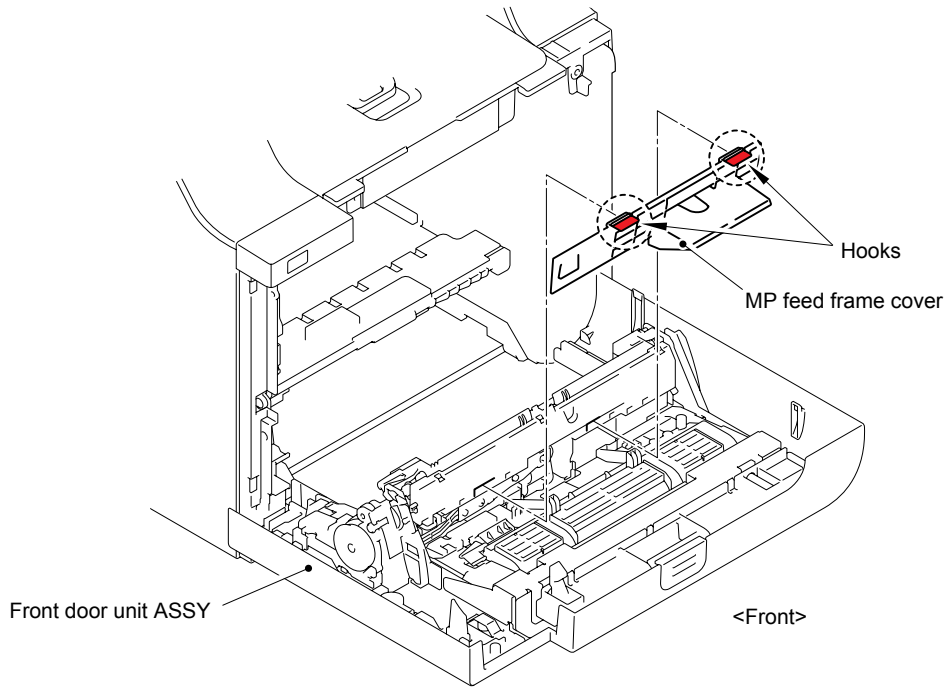

Fig. 3-11

- (3) Remove the MP lift arm 2.

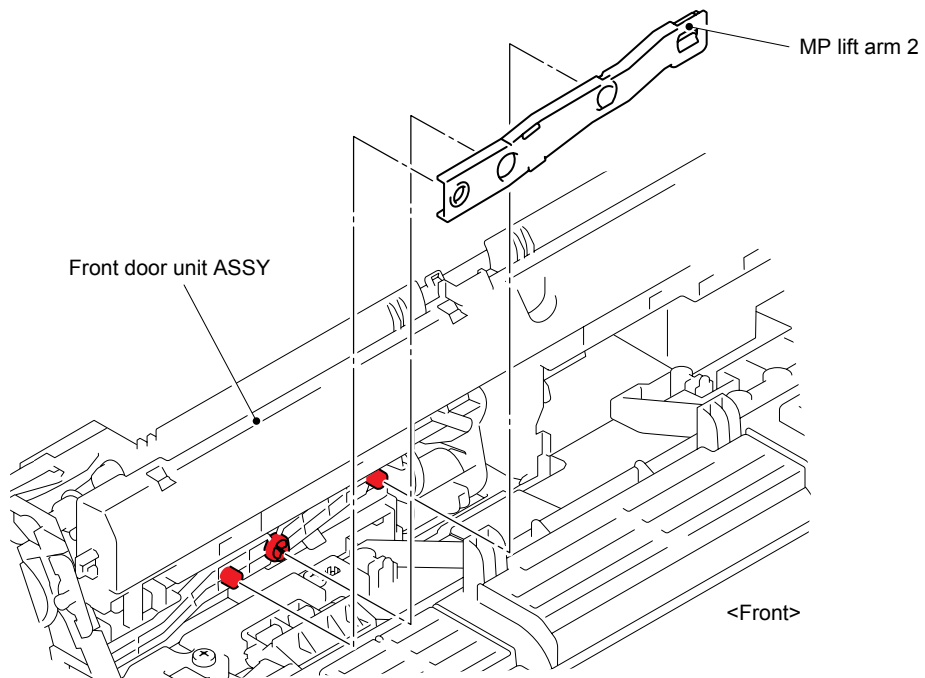

Fig. 3-12

- (4) Release the Hook to slide the Holder bush MP in the direction of arrow 4a, and then remove the Holder bush MP from the shaft of the MP roller holder ASSY.

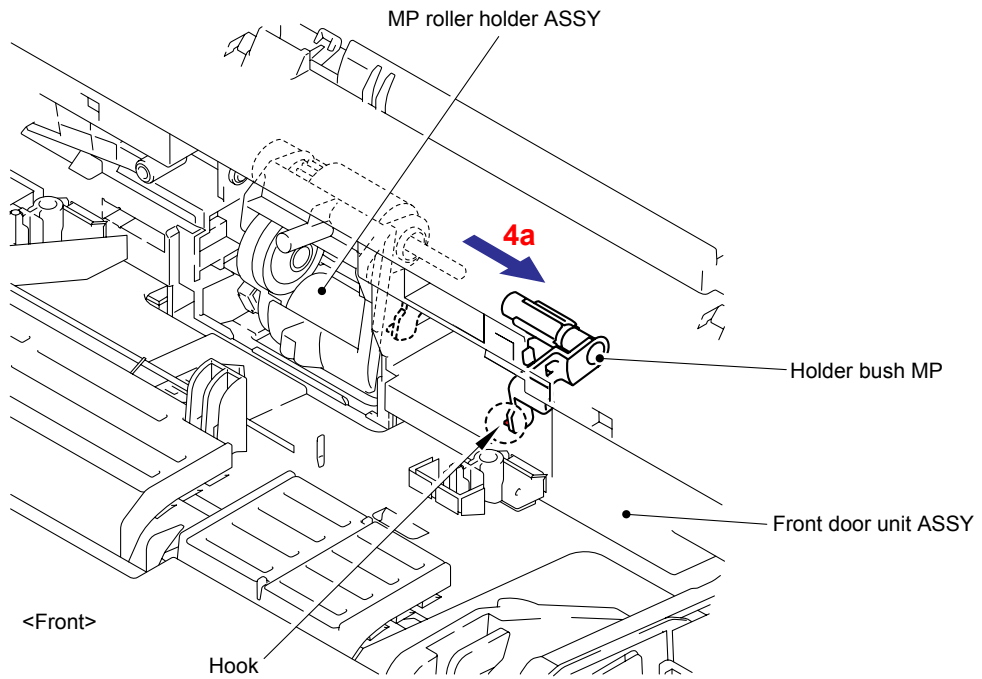

Fig. 3-13

- (5) Slide the MP roller holder ASSY in the direction of arrow 5a and slightly pull it down in the direction of arrow 5b. Then, remove it.

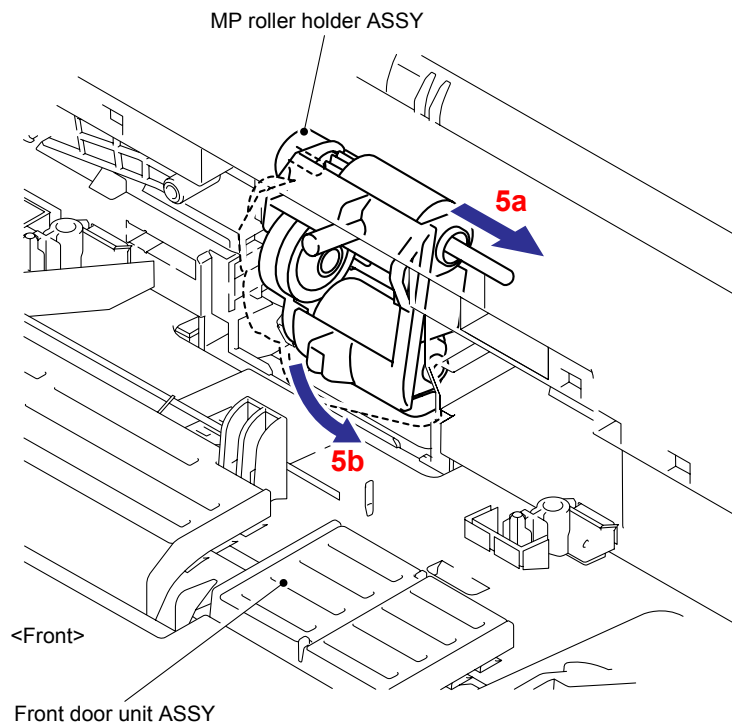

Fig. 3-14

- (6) Remove the Separation pad ASSY MP from the Front door unit ASSY.
- (7) Remove the Separation pad spring MP.

Note:

Be careful not to loose the Separation pad spring MP.

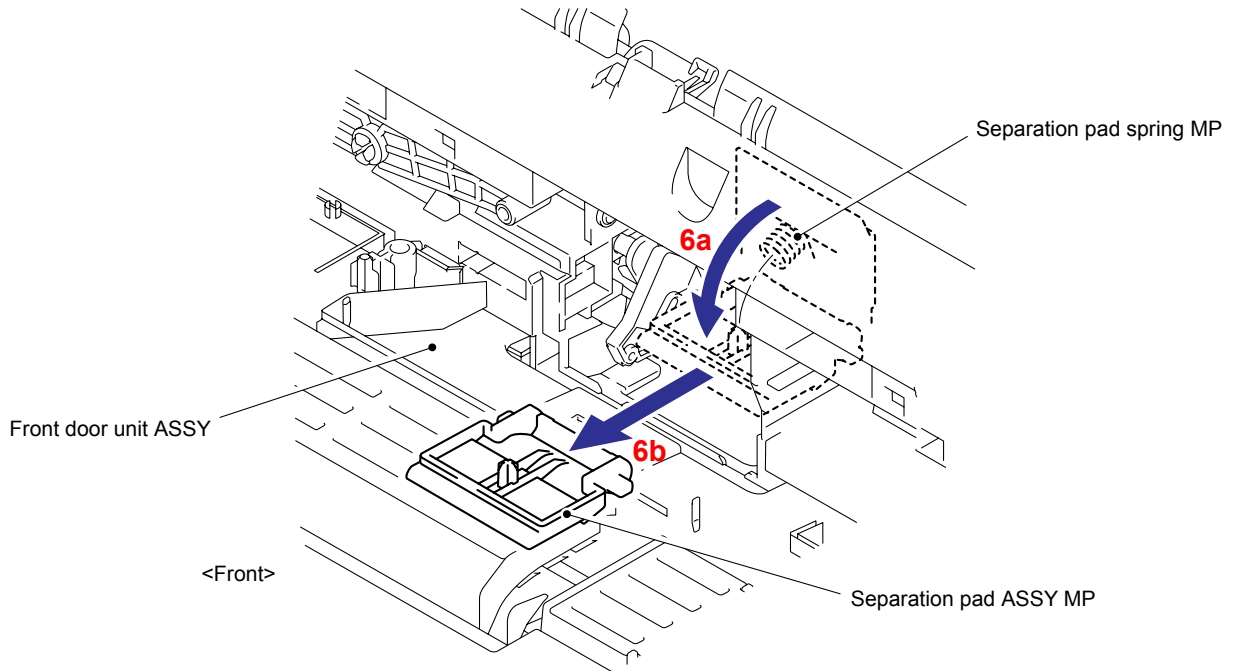

Fig. 3-15

8.5 Fuser Unit/ Toner Filter Frame ASSY

- (1) Open the Back cover.

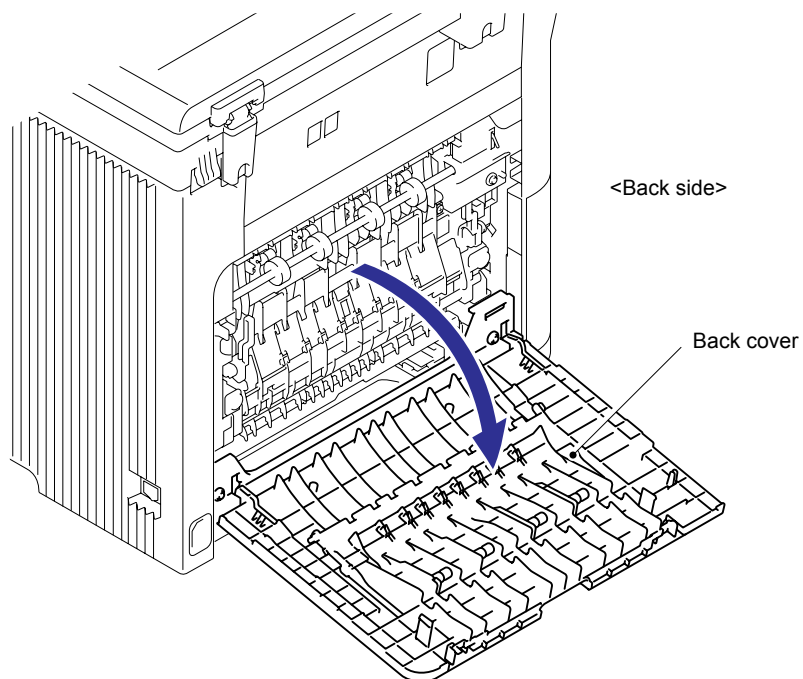

Fig. 3-16

- (2) Remove the two pan B M4x14 Taptite screws, and then pull out the Fuser unit to the back of the machine.

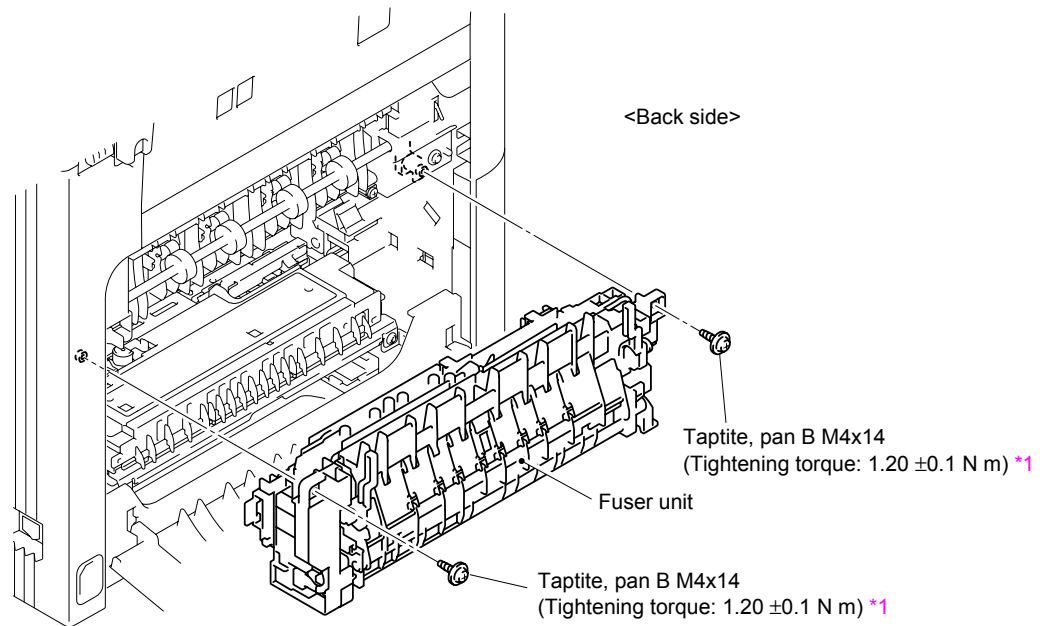

Fig. 3-17

***1 Tightening Note:**

When tightening the screw, slowly turn it counterclockwise (in the direction to loosen the screw) with your hand until you feel that the screw is a little dropped in the hole. Then, slightly turn it clockwise (in the direction to tighten the screw) with your hand and tighten it according to the specified torque with a screwdriver.

Assembling Note:

- When assembling the fuser unit, make sure that the two Harnesses are placed in the groove and under the rib of the Plastic frame. If they are not, then correct them as shown in the figure below.

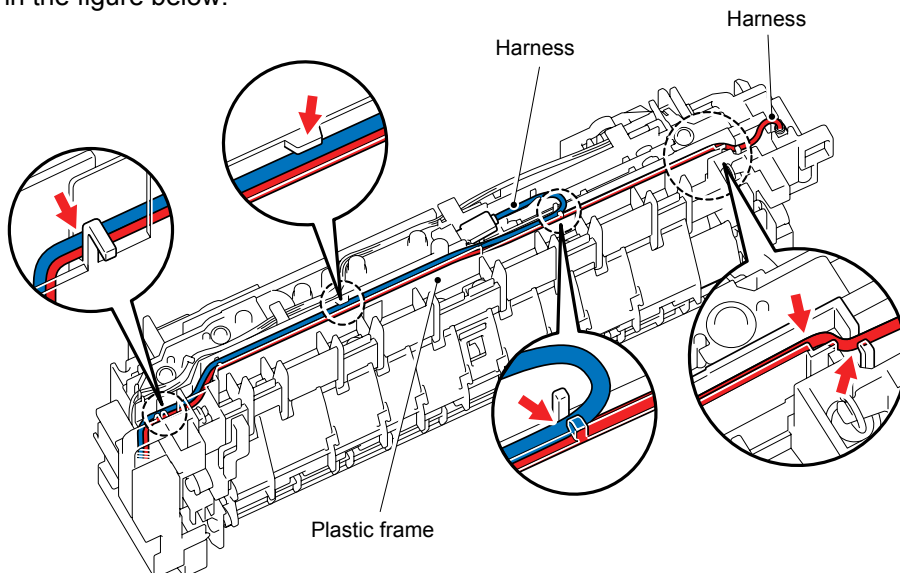

Fig. 3-18

- When assembling or disassembling the fuser unit, the sponge on the HV TR top cover might get scraped. If it is scraped, remove the scraped waste and clean the feeding path. After replacing the fuser unit, be sure to execute the test print and check that there are no print failures, such as vertical lines on the print result.

(3) Remove the Toner filter frame ASSY from the Paper eject ASSY DX/SX.

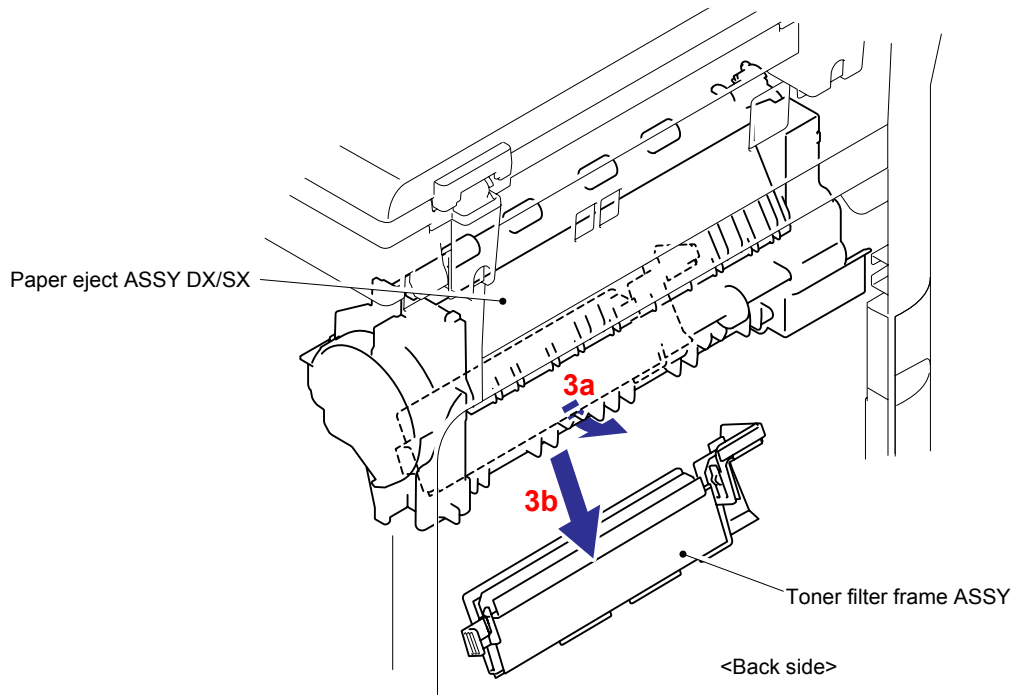

Fig. 3-19

8.6 Back Cover Upper

(1) Remove the two cup S M3x8 Taptite screws, and then remove the Back cover upper.

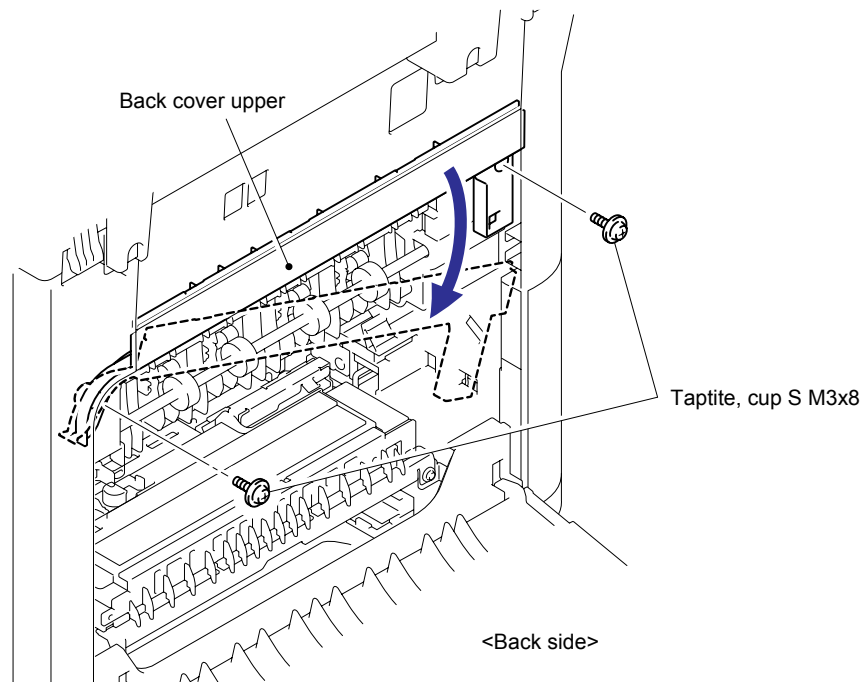

Fig. 3-20

8.7 Paper Eject ASSY DX/SX

(1) Remove the bind B M3x10 Taptite screw, and then remove the Drive shaft holder.

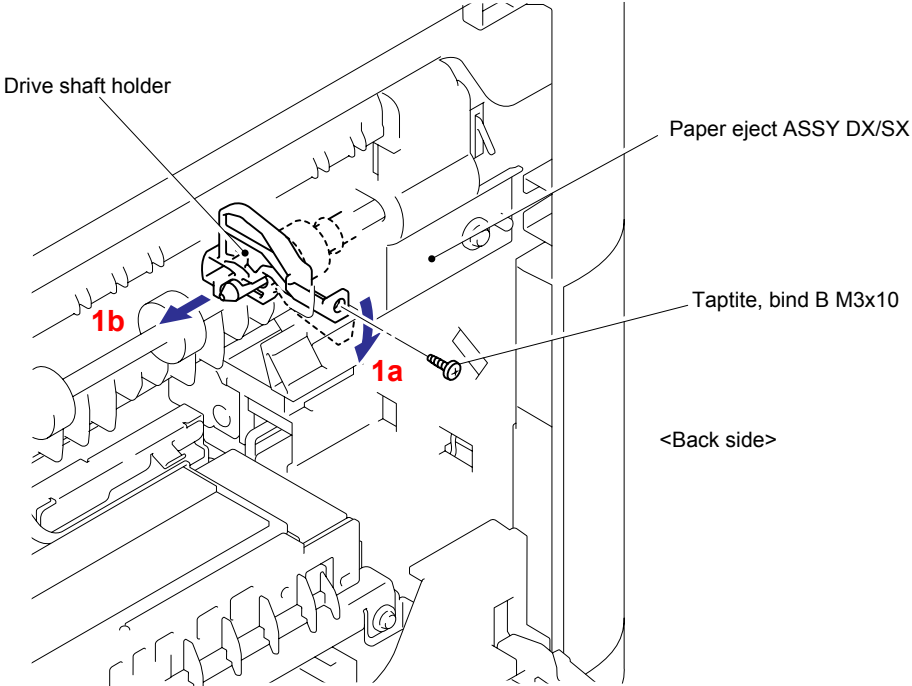

Fig. 3-21

(2) Release the Hook to remove the Fuser drive gear 18 from the shaft.

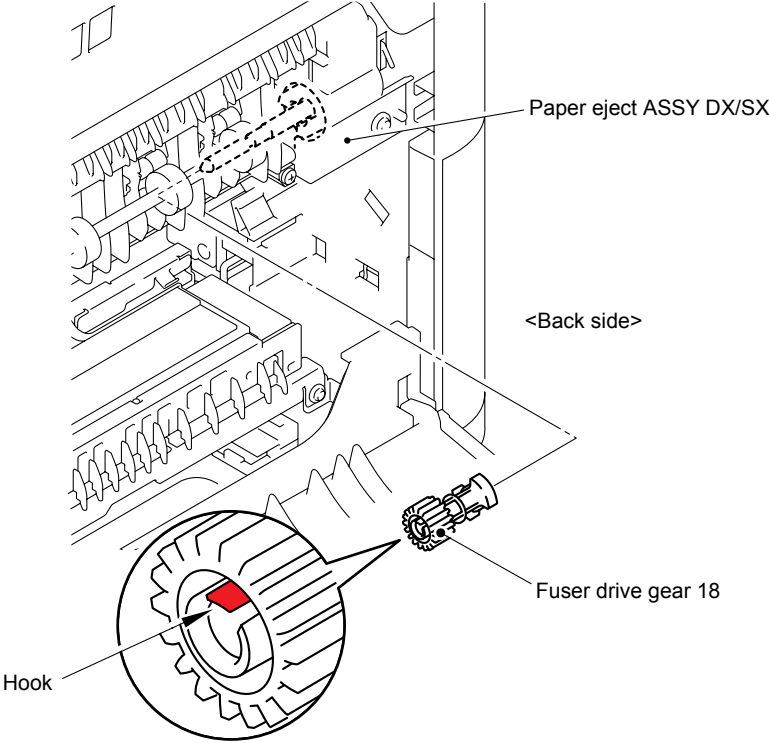

Fig. 3-22

- (3) Remove the two cup B M4x12 Taptite screws and cup S M3x6 Taptite screw.
- (4) Disconnect the Connector.
- (5) Remove the Paper eject ASSY DX/SX.

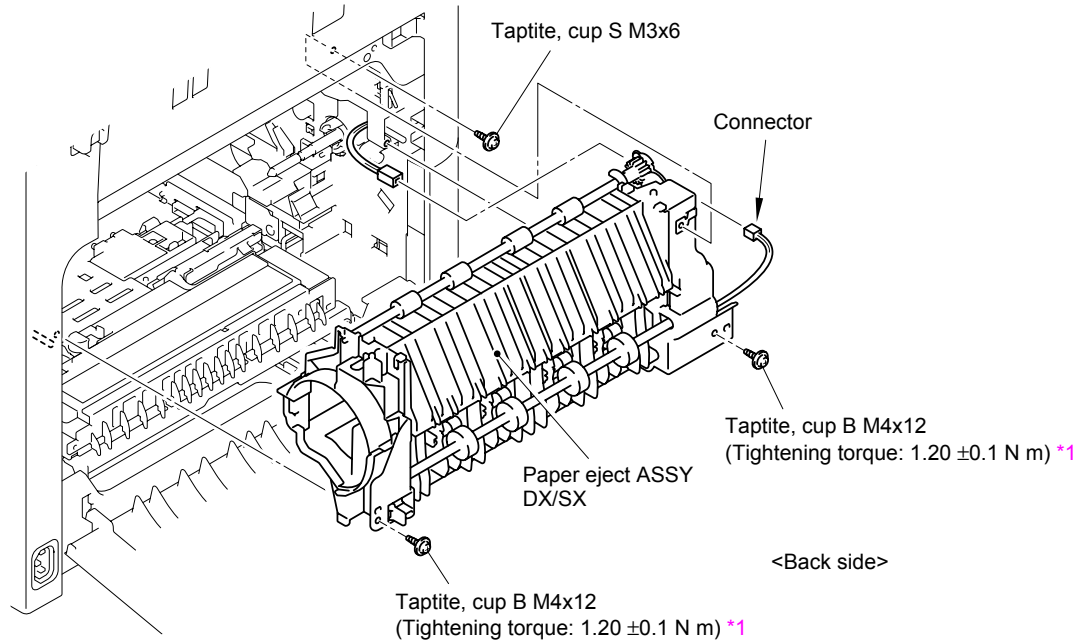

Fig. 3-23

***1 Tightening Note:**

When tightening the screw, slowly turn it counterclockwise (in the direction to loosen the screw) with your hand until you feel that the screw is a little dropped in the hole. Then, slightly turn it clockwise (in the direction to tighten the screw) with your hand and tighten it according to the specified torque with a screwdriver.

Parts Replacement Note:

The Paper eject ASSY DX/SX is supplied with the Drive shaft holder already fitted. When replacing the Paper eject ASSY DX/SX, remove the Drive shaft holder from the supplied Paper eject ASSY DX/SX first, then assemble the Paper eject ASSY DX/SX.

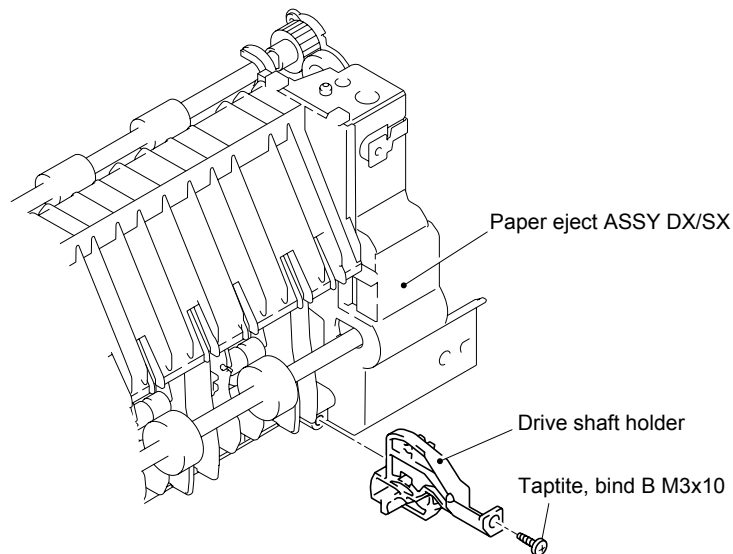

Fig. 3-24

Assembling Note:

- (1) Put the Drive shaft holder into the Shaft of the Frame unit.
- (2) Align the Hook and Pin of the Drive shaft holder with the hole on the Paper eject ASSY DX/SX while inclining the Drive shaft holder 10 degrees downwards.
- (3) Move the Drive shaft holder to the direction of the arrow 3 to align it with the screw hole of the Paper eject ASSY DX/SX, and secure the Drive shaft holder with the bind B M3x10 Taptite screw.

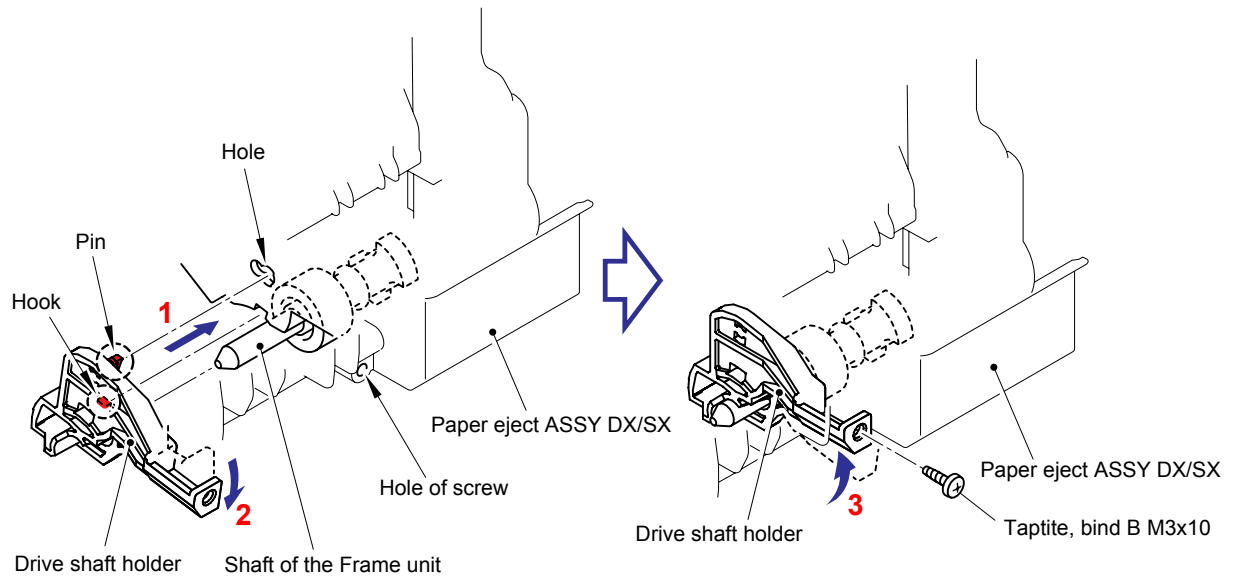

Fig. 3-25

8.8 Back Cover ASSY

(1) Turn the Cord holder 90 degrees and remove it from the Joint cover ASSY.

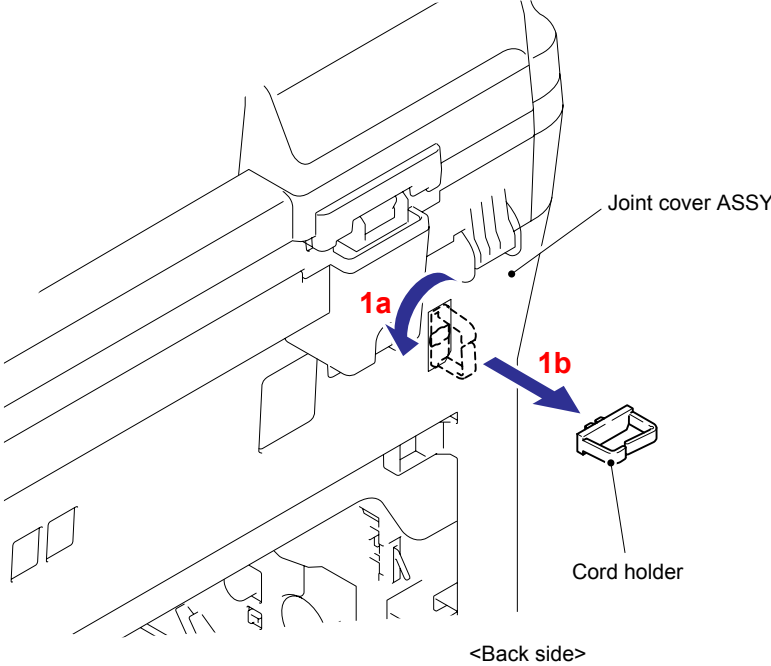

Fig. 3-26

(2) Remove the two cup S M3x8 Taptite screws, and then remove the Back cover ASSY.

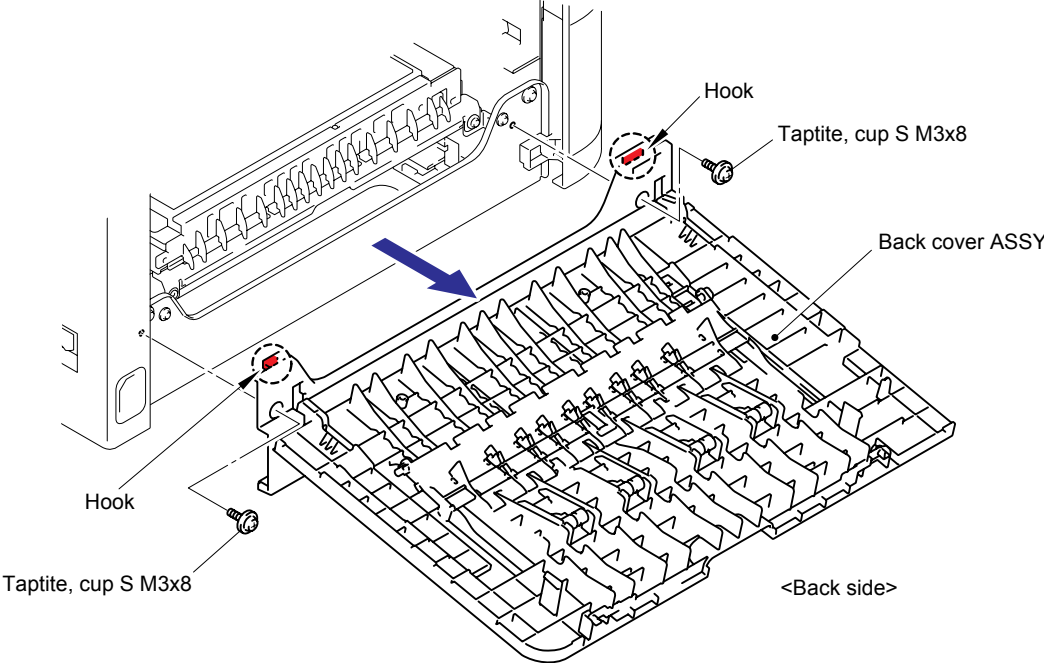

Fig. 3-27

8.9 Paper Guide DX/ HV TR Top Cover

- (1) Release the two Bosses, and then remove the Paper guide DX from the Transfer HVPS PCB unit while lifting it up slightly.

Note:

When removing the Paper guide, be careful not to damage the two Ribs.

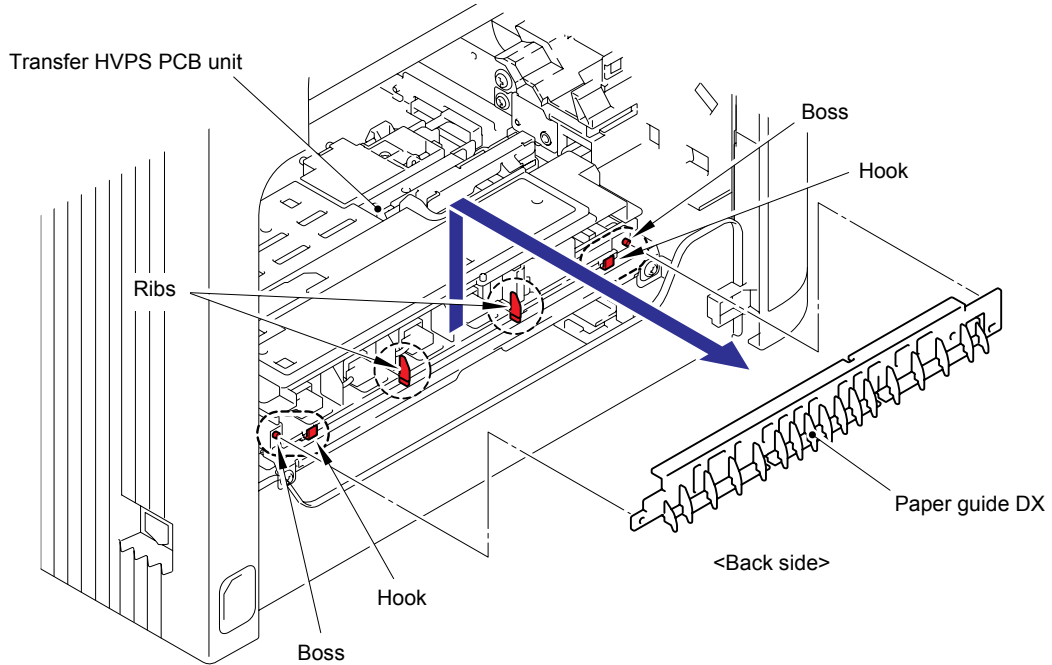

Fig. 3-28

- (2) Slide the HV TR top cover to the left hand side and release the four Hooks. Then, remove the HV TR top cover.

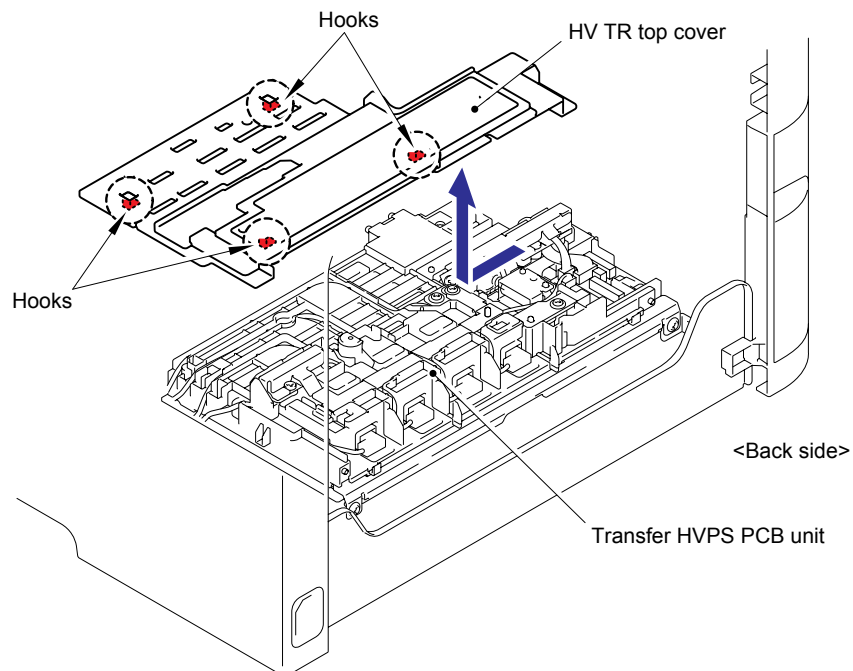

Fig. 3-29

8.10 Transfer HVPS PCB Unit

- (1) Disconnect the four Connectors from the Electrode head.

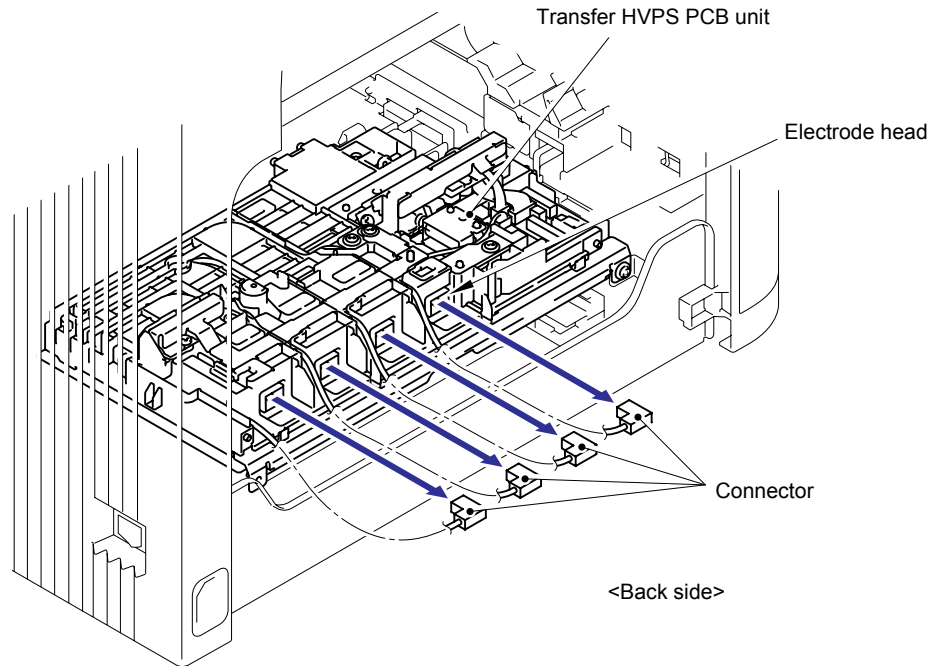

Fig. 3-30

- (2) Disconnect the flat cable (CN1) and two connectors (CN5, CN8) from the Registration relay PCB unit.

Note:

- After disconnecting the flat cable(s), check that each cable is not damaged at its end or short-circuited.
- When connecting the flat cable(s), do not insert it at an angle. After insertion, check that the cable is not at an angle.

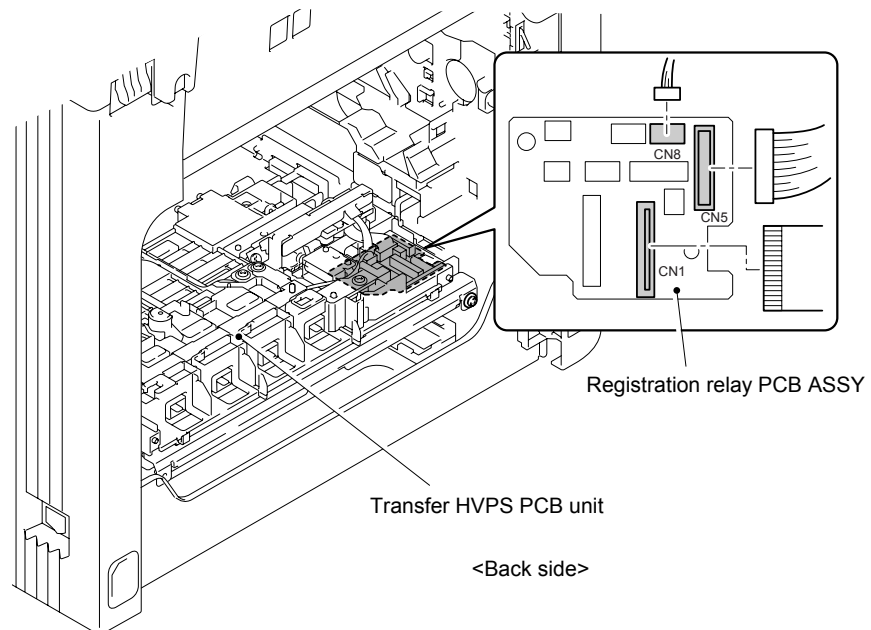

Fig. 3-31

- (3) Remove the two cup S M3x6 Taptite screws, and then remove the Transfer HVPS PCB unit.

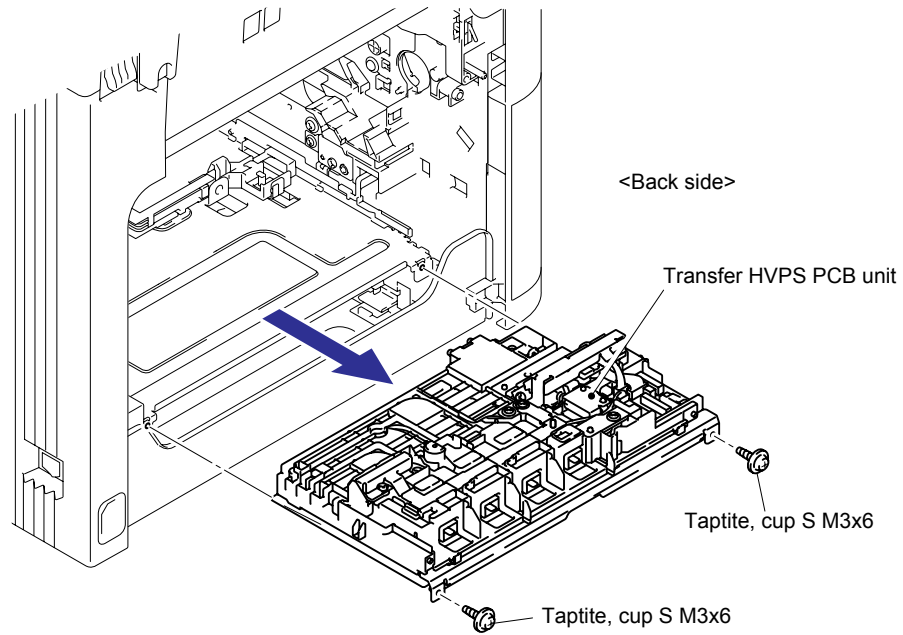

Fig. 3-32

8.11 Registration-mark Sensor PCB ASSY 1, 2/ Density Sensor/ Registration Relay PCB ASSY/ Transfer HVPS PCB ASSY

- (1) Remove the bind B M3x8 Taptite screw, and then remove the Earth plate 3.

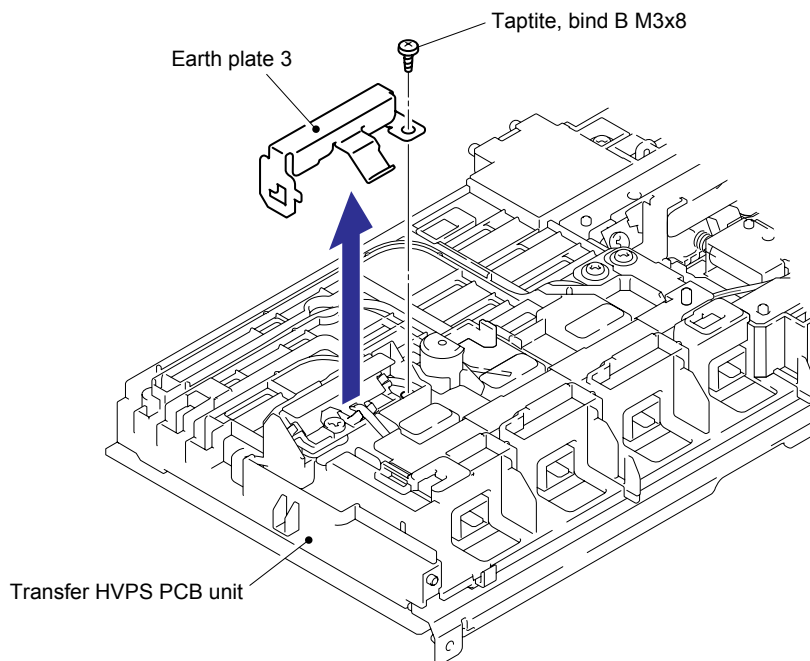

Fig. 3-33

- (2) Remove the two bind B M3x8 Taptite screws, and then remove the Density shield plate 1.

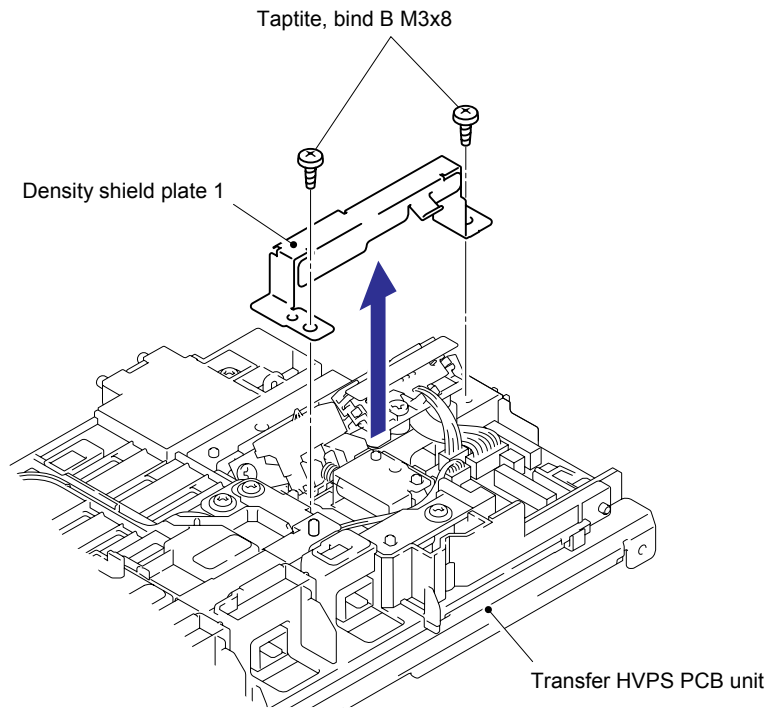

Fig. 3-34

- (3) Remove the cup S M3x6 Taptite screw, and then remove the Earth plate 2.

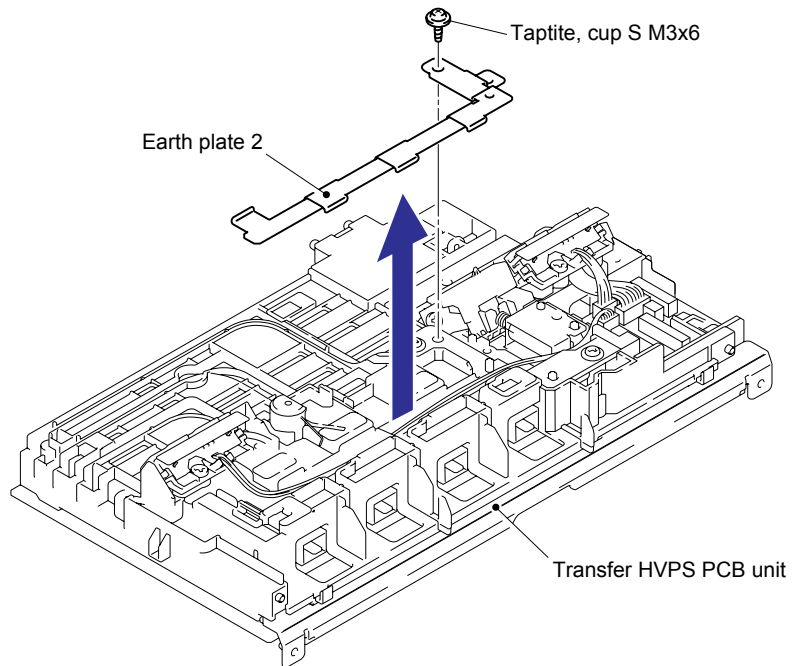

Fig. 3-35

- (4) Disconnect the Connector (CN3) of the Registration-mark sensor PCB ASSY 1.
- (5) Remove the bind B M3x8 Taptite screw, and then remove the Registration-mark sensor PCB ASSY 1 from the Density sensor holder.

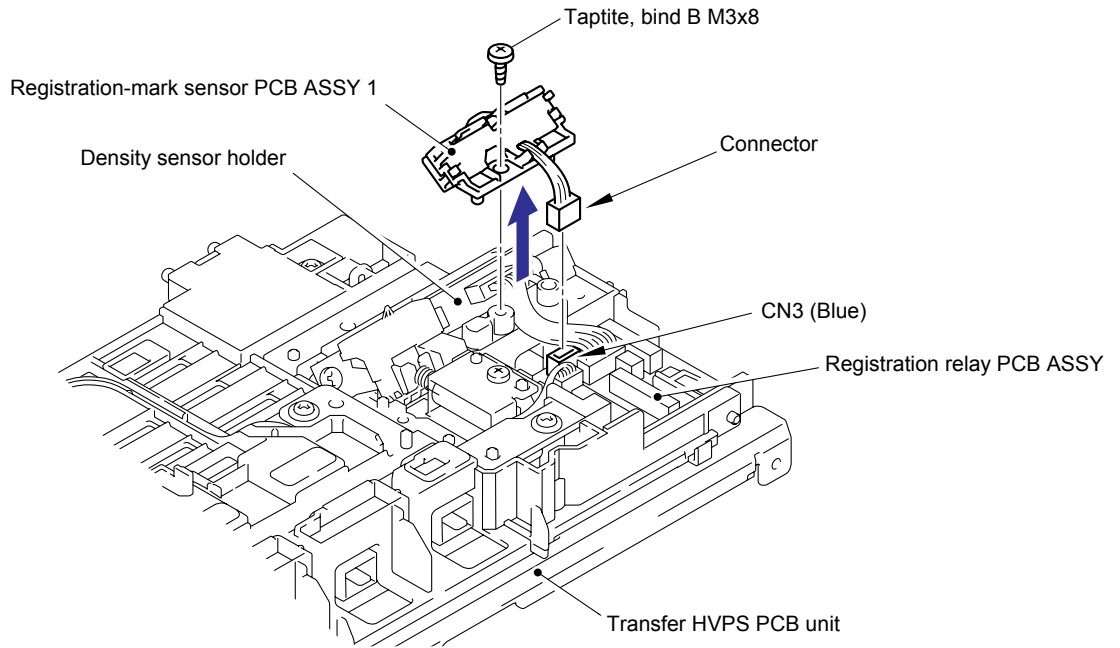

Fig. 3-36

- (6) Disconnect the Connector (CN4) of the Registration-mark sensor PCB ASSY 2.
- (7) Remove the bind B M3x8 Taptite screw, and then remove the Registration-mark sensor PCB ASSY 2.

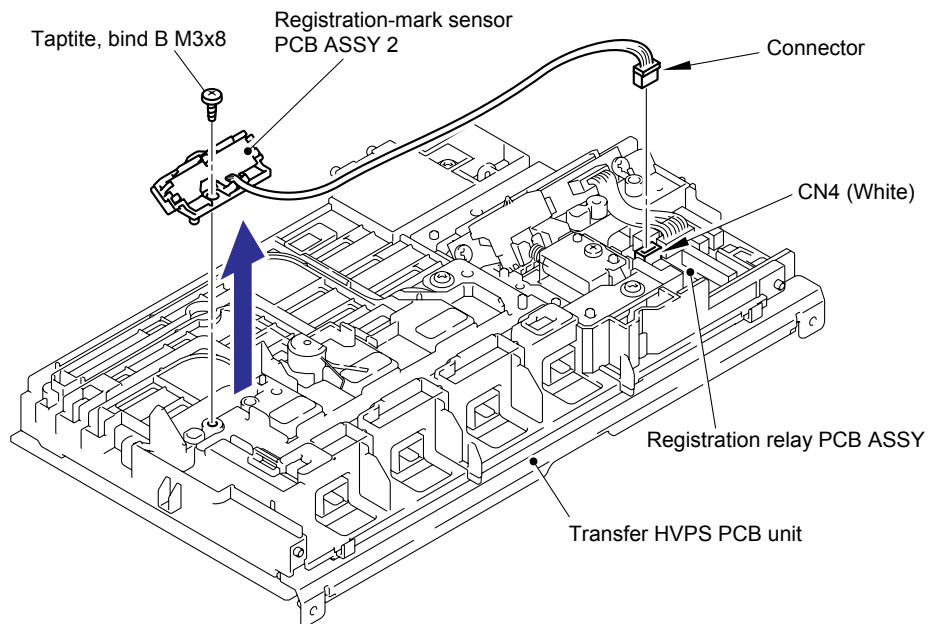

Fig. 3-37

- (8) Disconnect the Connector (CN7), and remove the two bind B M3x8 Taptite screws, and then remove the Density sensor.

Note:

Do not touch the Variable resistor on the back of the Density sensor.

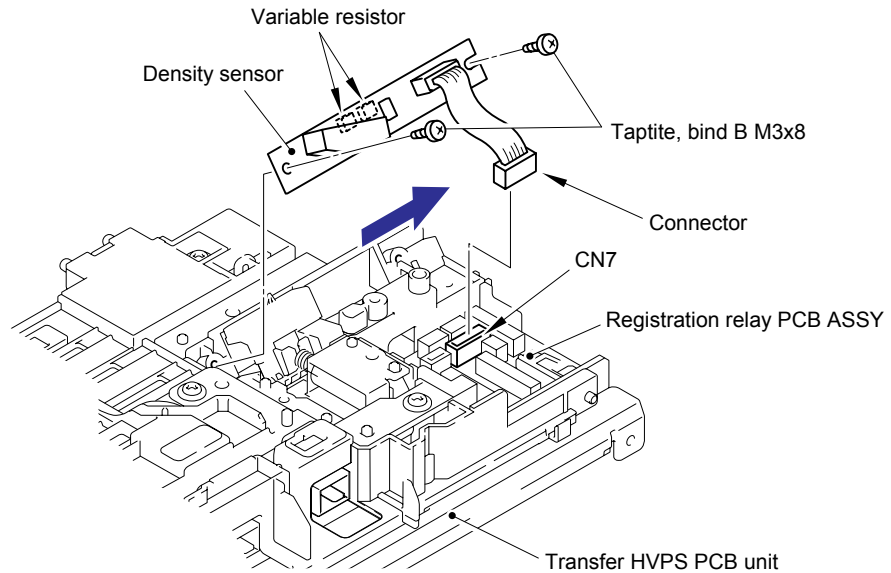

Fig. 3-38

- (9) Disconnect the Flat cable (CN2) and three Connectors (CN6, CN9, CN13) from the Registration relay PCB ASSY.

Note:

- After disconnecting the flat cable(s), check that each cable is not damaged at its end or short-circuited.
- When connecting the flat cable(s), do not insert it at an angle. After insertion, check that the cable is not at an angle.

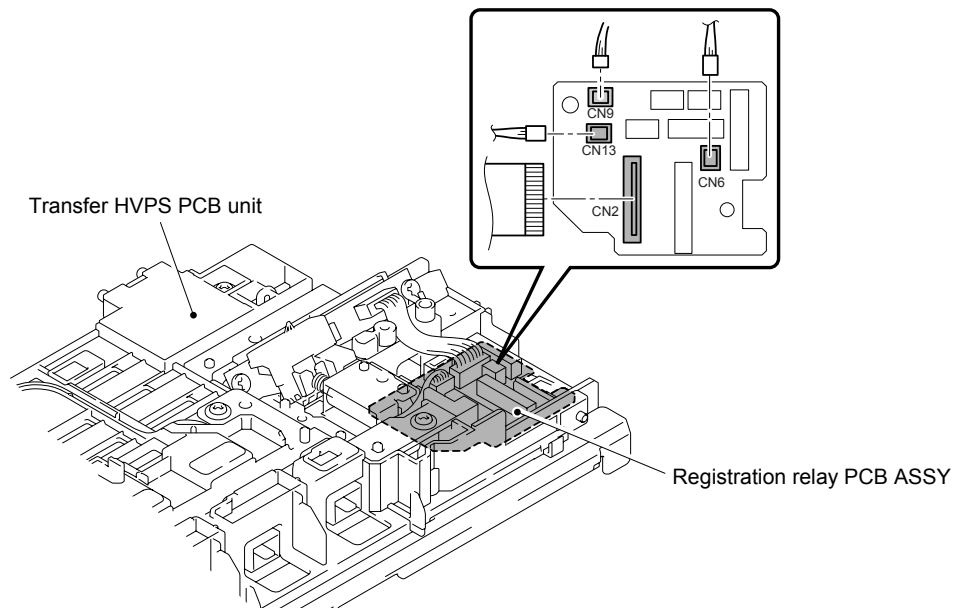

Fig. 3-39

- (10) Turn the Transfer HVPS PCB ASSY upside down. Remove the bind B M3x8 Taptite screw from the Registration relay PCB ASSY.
- (11) Remove the Registration relay PCB ASSY from the Transfer HVPS PCB unit.

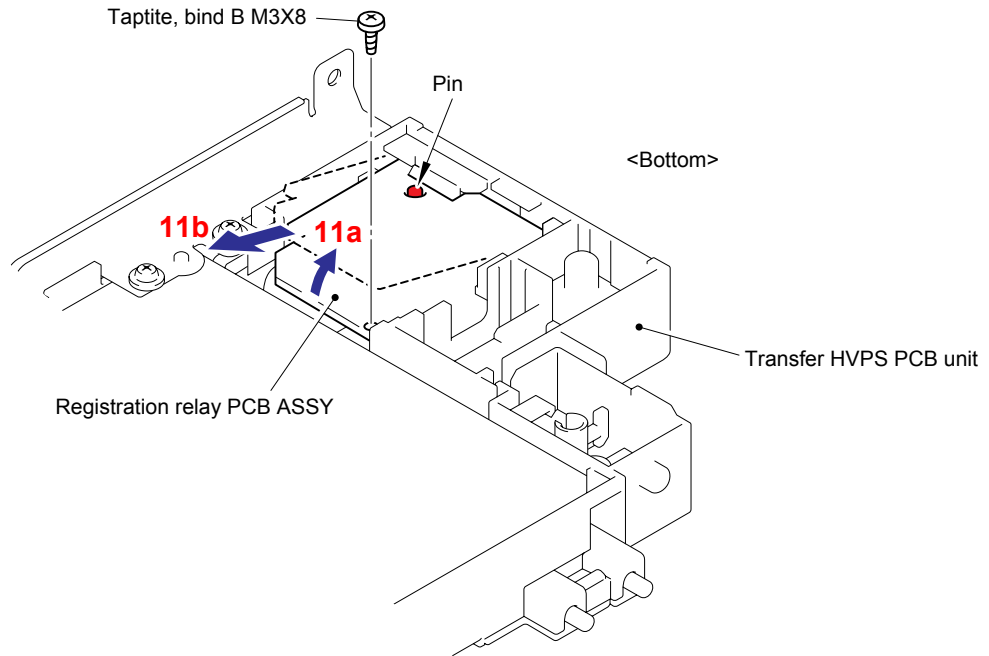

Fig. 3-40

- (12) Remove the three cup B 3x10 Taptite screws and one cup S M3x6 Taptite screw, and then remove the HV TR ground plate and Transfer HVPS PCB ASSY.

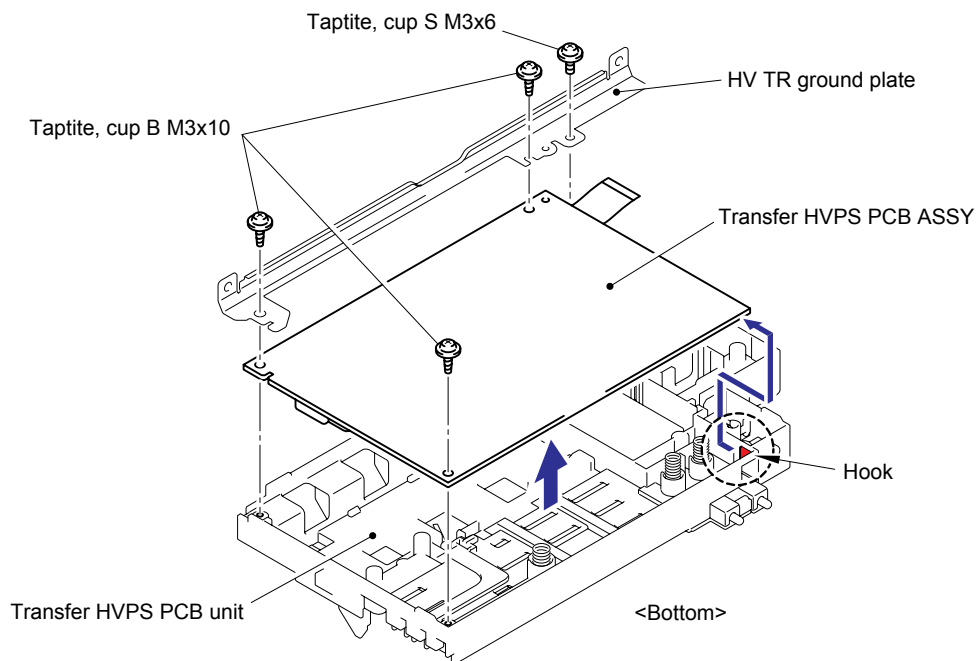

Fig. 3-41

Assembling Note:

When assembling the Registration relay PCB ASSY, put the section "A" of the Registration relay PCB ASSY into the section "B" of the Transfer HVPS PCB unit.

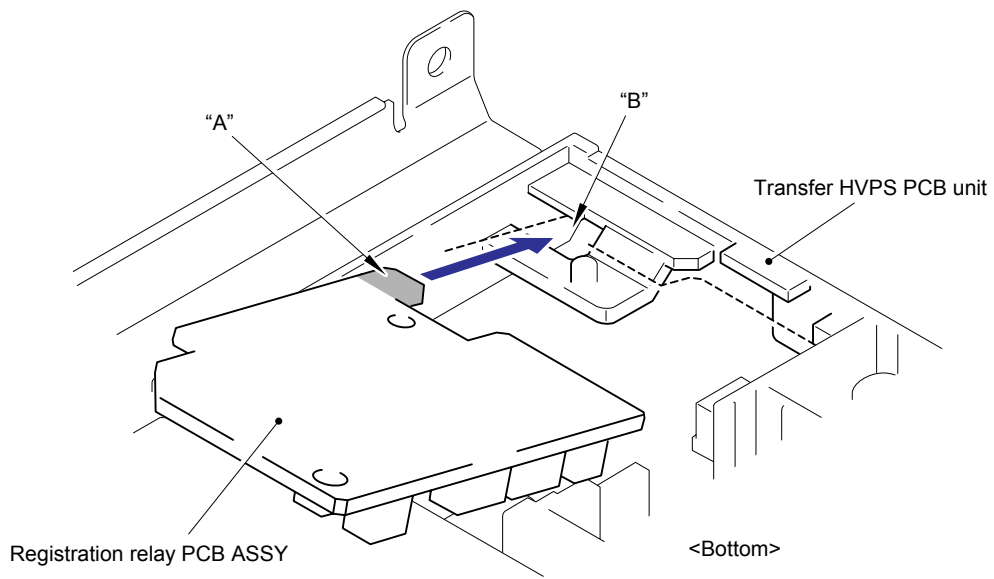

Fig. 3-42

8.12 Side Cover L ASSY

- (1) Remove the cup S M3x8 Taptite screw and three cup B M4x12 Taptite screws.
- (2) Release the three Hooks on the bottom and the two hooks on the back side, and then remove the Side cover L ASSY.

Note:

When removing the Side cover L ASSY, pay attention to the Wire support rope.

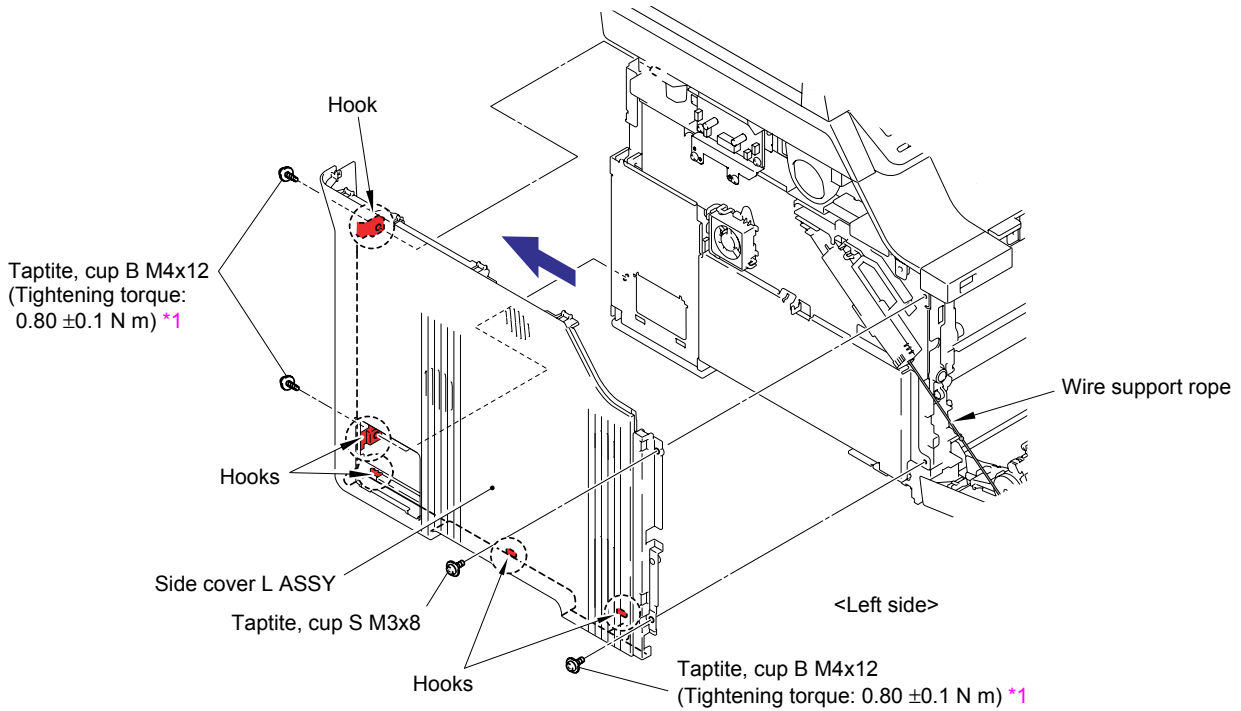

Fig. 3-43

***1 Tightening Note:**

When tightening the screw, slowly turn it counterclockwise (in the direction to loosen the screw) with your hand until you feel that the screw is a little dropped in the hole. Then, slightly turn it clockwise (in the direction to tighten the screw) with your hand and tighten it according to the specified torque with a screwdriver.

- (3) Remove the Access cover from the Side cover L ASSY.

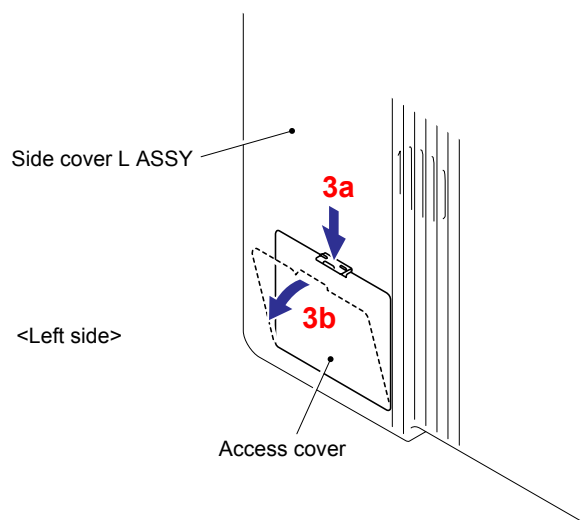

Fig. 3-44

8.13 Side Plate LB

- (1) Remove the three cup S M3x6 Taptite screws, cup B M4x12 Taptite screw and cup S M4x8 Taptite screw, and then remove the Side plate LB.

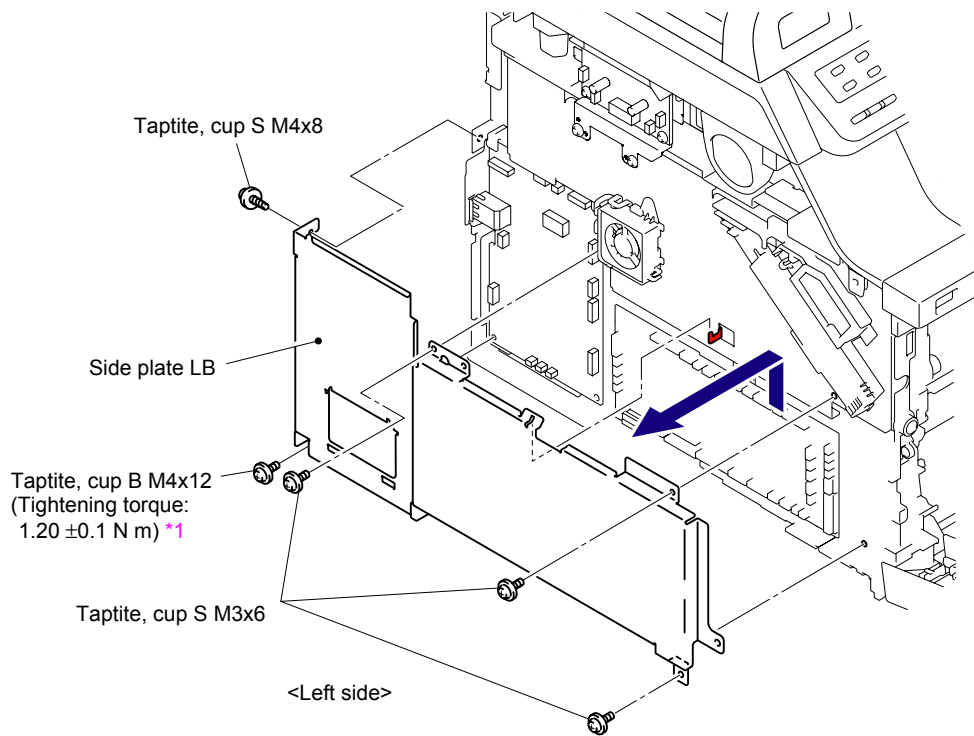

Fig. 3-45

***1 Tightening Note:**

When tightening the screw, slowly turn it counterclockwise (in the direction to loosen the screw) with your hand until you feel that the screw is a little dropped in the hole. Then, slightly turn it clockwise (in the direction to tighten the screw) with your hand and tighten it according to the specified torque with a screwdriver.

8.14 Drum Unit Fan (OPC)

(1) Disconnect the Connector from the Engine PCB ASSY, and then remove the Drum unit fan (OPC).

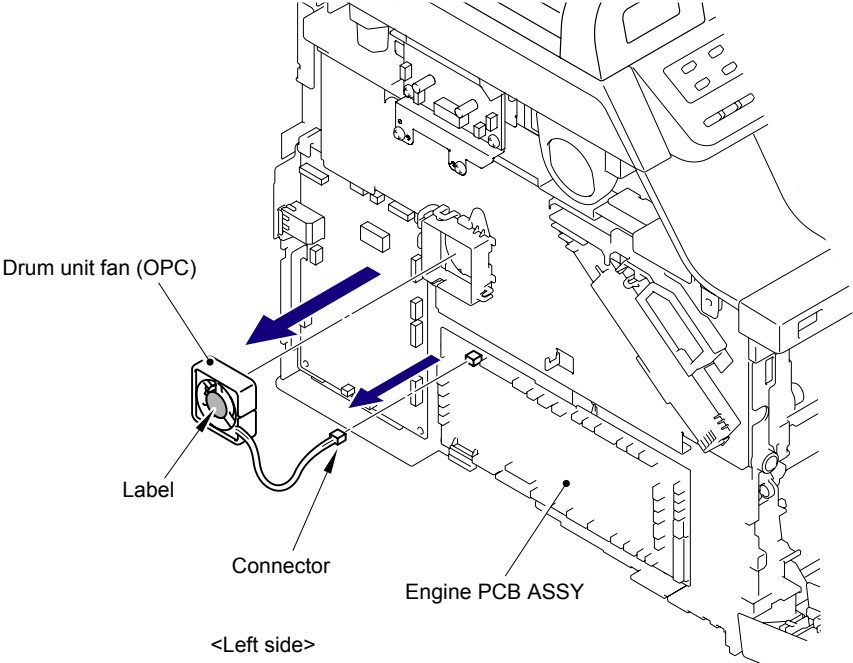

Fig. 3-46

Assembling Note:

When assembling the Drum unit fan (OPC), place it so that the attached Label faces outwards.

8.15 Side Cover R ASSY

- (1) Remove the two cup B M4x12 Taptite screws and two cup S M4x8 Taptite screws.
- (2) Release the one Hook on the front side, two Hooks on the bottom and the two Hooks on the back side, and then remove the Side cover R ASSY.

Note:

When removing the Side cover R ASSY, be careful not to damage section "A".

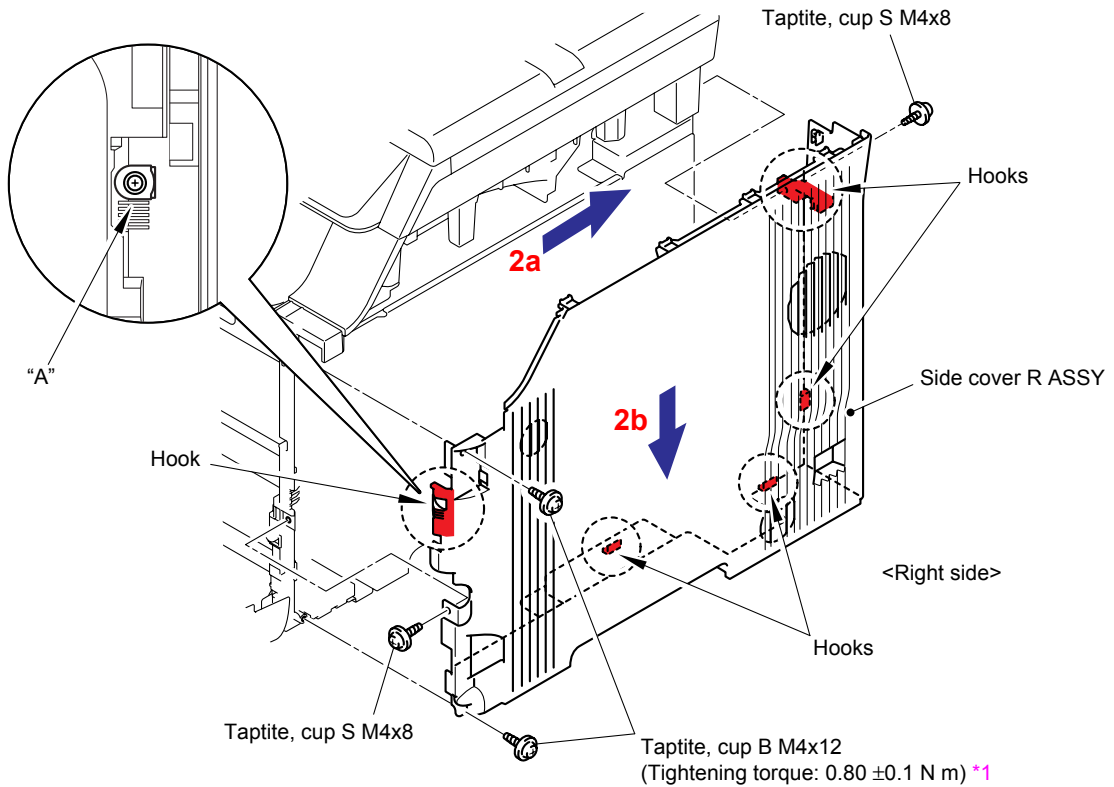

Fig. 3-47

***1 Tightening Note:**

When tightening the screw, slowly turn it counterclockwise (in the direction to loosen the screw) with your hand until you feel that the screw is a little dropped in the hole. Then, slightly turn it clockwise (in the direction to tighten the screw) with your hand and tighten it according to the specified torque with a screwdriver.

8.16 Paper stopper

- (1) Open the Document scanner unit.
- (2) Open the Paper stopper and release the Pins on both sides.

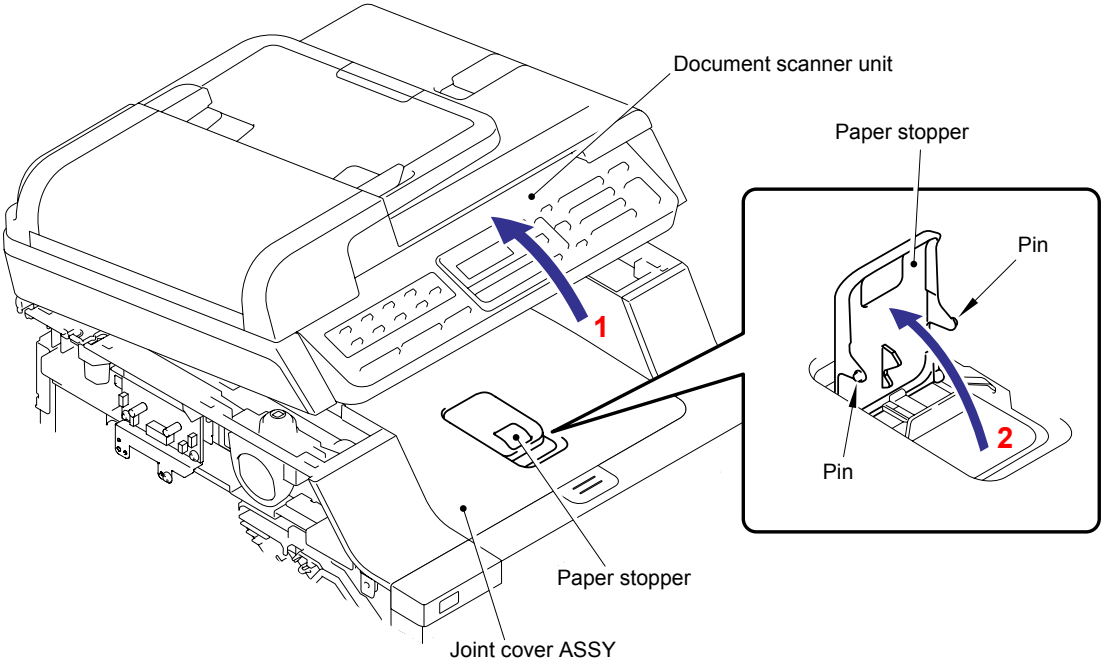

Fig. 3-48

- (3) Turn the Paper stopper in the direction of arrow 3a and remove it from the Joint cover ASSY.

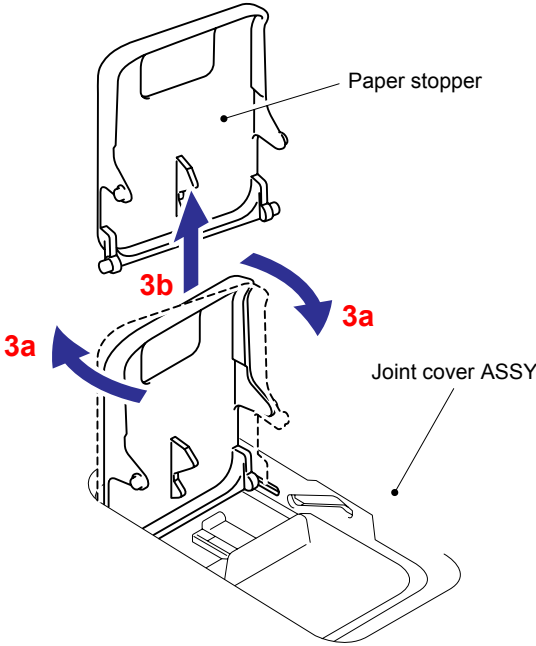

Fig. 3-49

8.17 Driver PCB ASSY

- (1) Disconnect the four Connectors (CN1, CN2, CN3, CN5) from the Driver PCB ASSY.

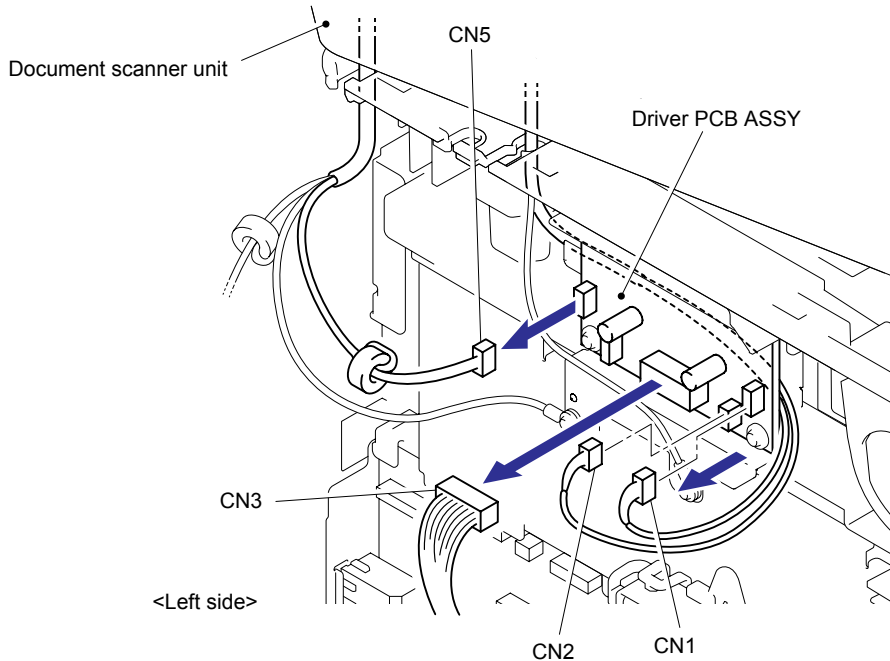

Fig. 3-50

- (2) Remove the cup S M3x6 Taptite screw, and then remove the FG harness ADF.
- (3) Remove the cup S M3x6 Taptite screw, and then remove the FG harness FB.
- (4) Remove the Driver PCB ASSY and Driver PCB shield.

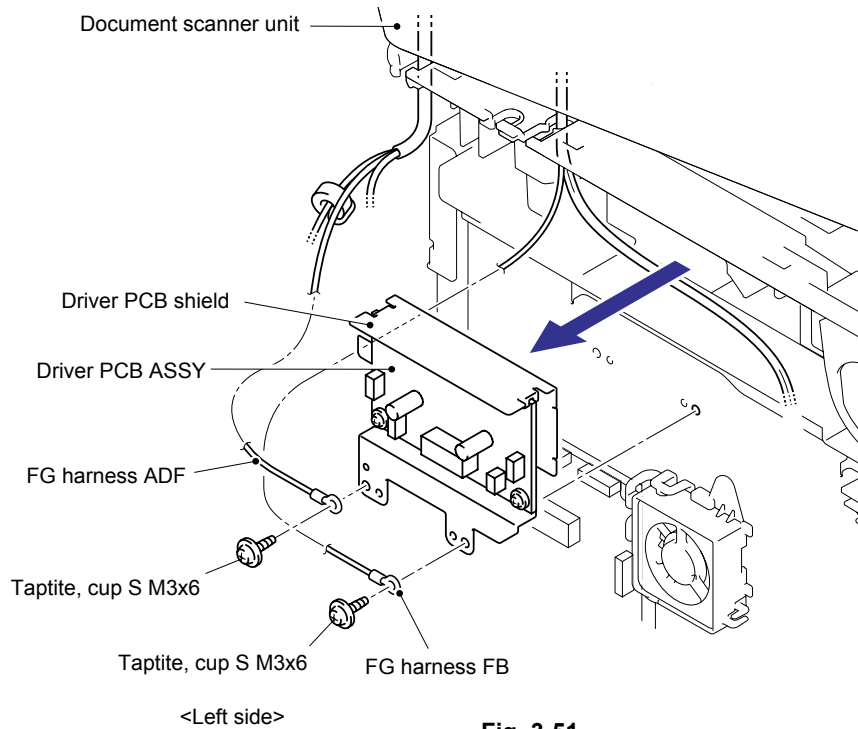

Fig. 3-51

- (5) Remove the two cup S M3x6 Taptite screws, and then remove the Driver PCB ASSY from the Driver PCB shield.

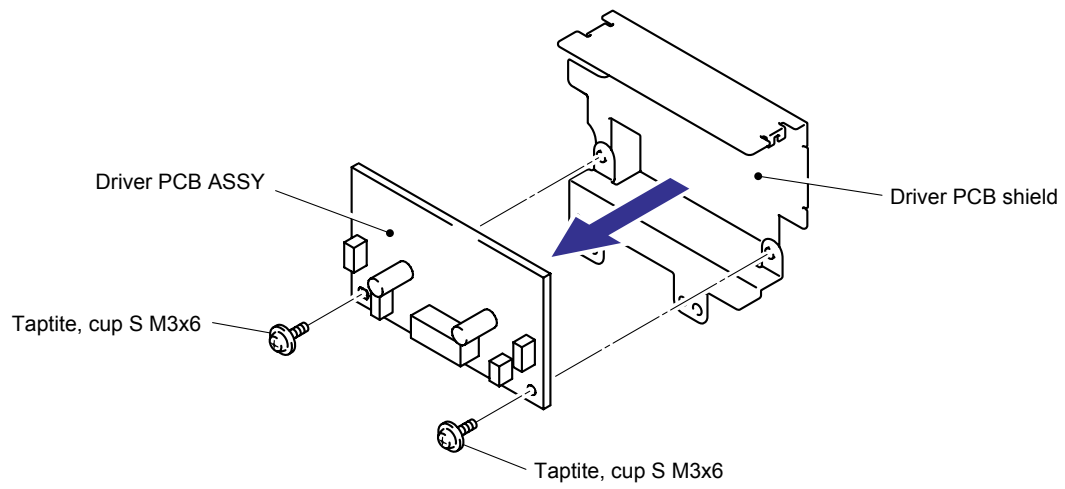

Fig. 3-52

8.18 Document Scanner Unit

- (1) Disconnect the Connector (CN14) from the Main PCB ASSY.
- (2) Disconnect the Connector (CN21) and Flat cable (CN18) from the Main PCB ASSY.

Note:

- After disconnecting the flat cable(s), check that each cable is not damaged at its end or short-circuited.
- When connecting the flat cable(s), do not insert it at an angle. After insertion, check that the cable is not at an angle.

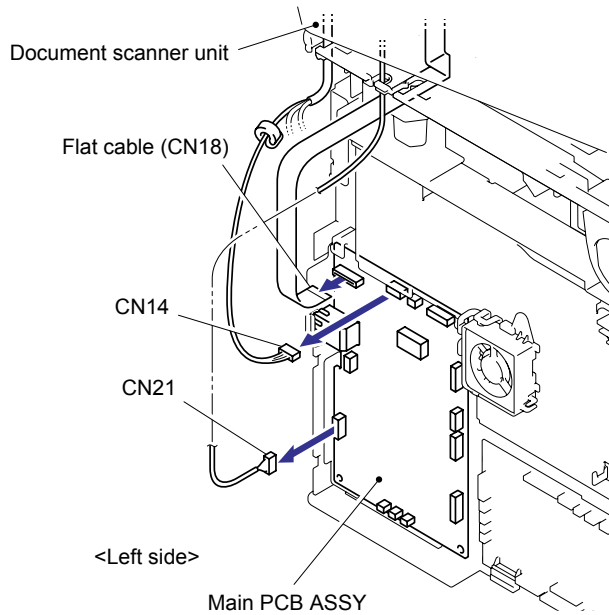

Fig. 3-53

- (3) Open the Document scanner unit, and then release the Hooks of the Pull arms L and R from the joint of the Document scanner unit.

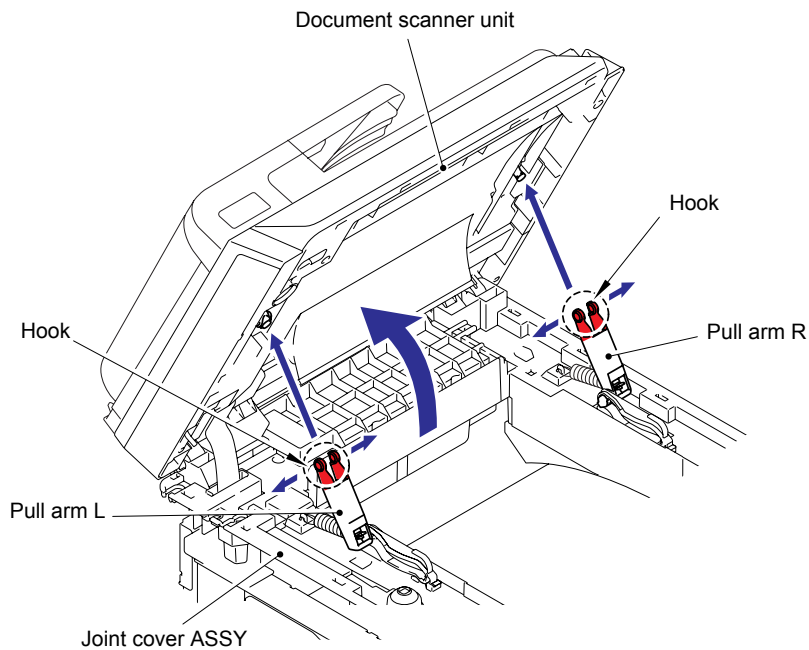

Fig. 3-54

- (4) Remove the Left and Right Pull arms and Pull arm springs from the Pull arm guide.

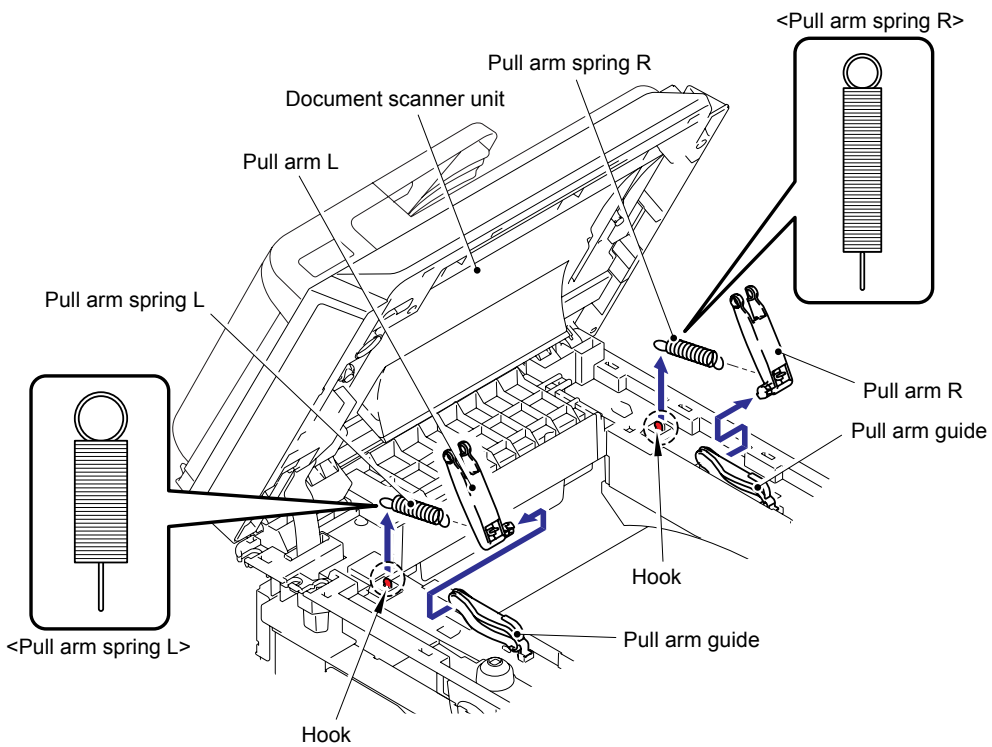

Fig. 3-55

Assembling Note:

When assembling the Pull arm springs Left and Right, be sure to assemble each of the Pull arm spring correctly. (Left is shorter and thicker and Right is longer and thinner) See Fig. 3-53.

- (5) Remove the Document scanner unit from the Joint cove ASSY by lifting upwards.

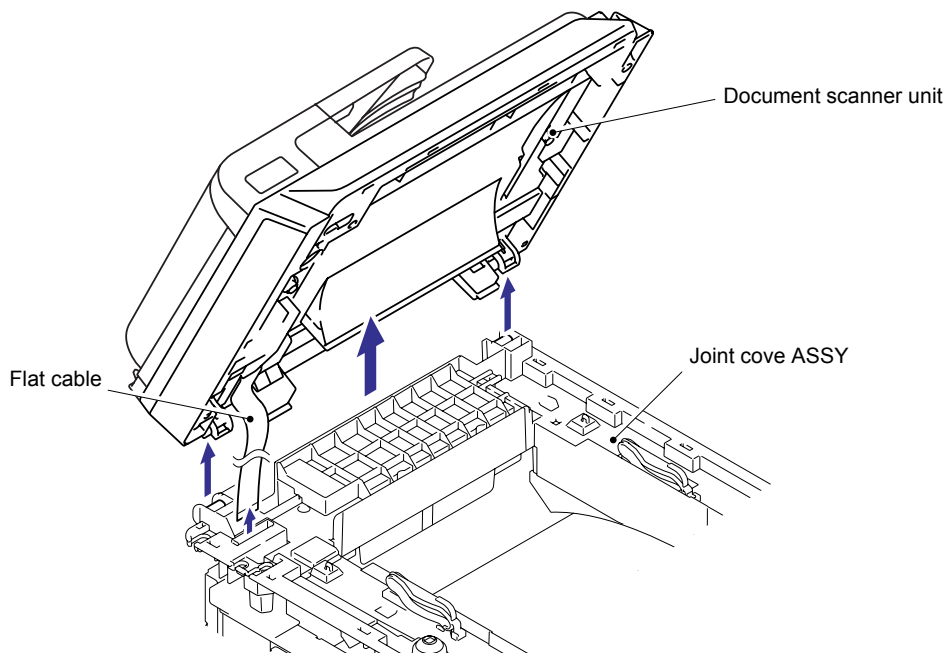

Fig. 3-56

- (6) Remove the two bind B M4x12 Taptite screws from the ADF unit.

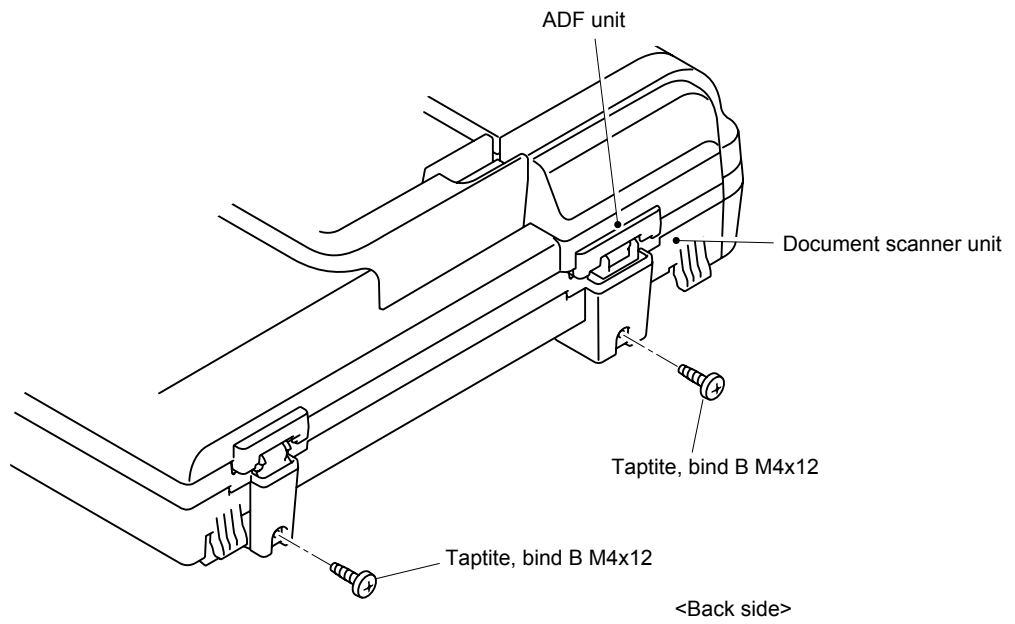

Fig. 3-57

- (7) Open the ADF unit. Push the Ferrite core of the ADF harness through the hole on the Document scanner unit while lifting up the ADF unit slightly. Then, remove the ADF unit.

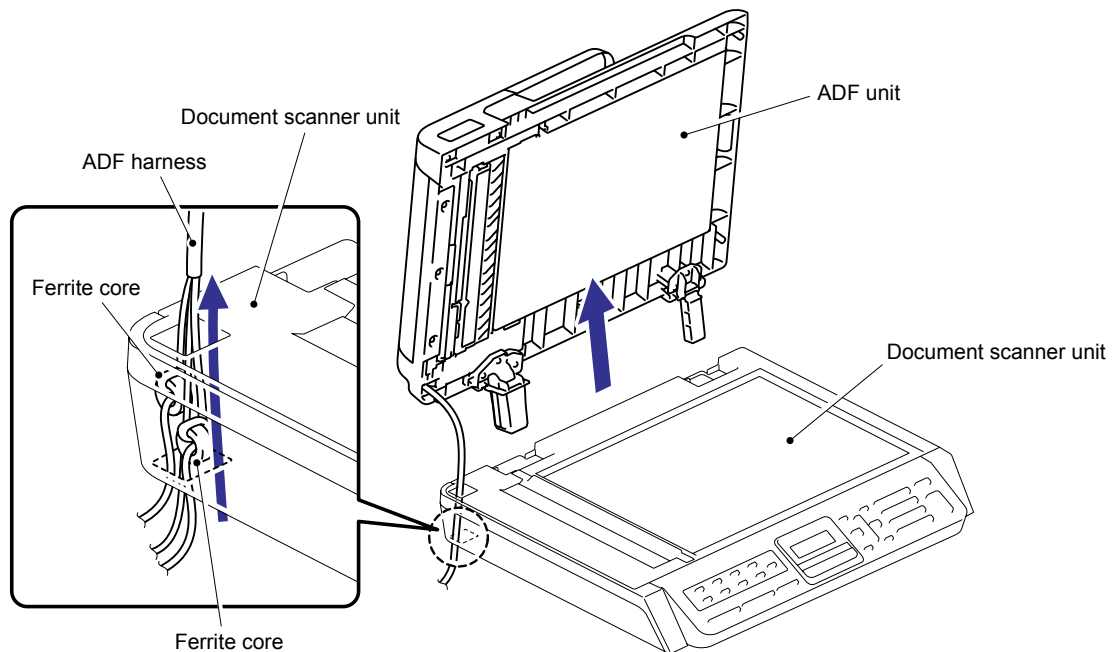

Fig. 3-58

8.19 ADF Unit

- (1) Turn the ADF unit upside down.
- (2) Remove the three cup B M3x10 Taptite screws, and then remove the Hinge ASSY L.
- (3) Remove the Hinge arm R from the Hinge base R.
- (4) Remove the three cup B M3x10 Taptite screws, and then remove Hinge base R.

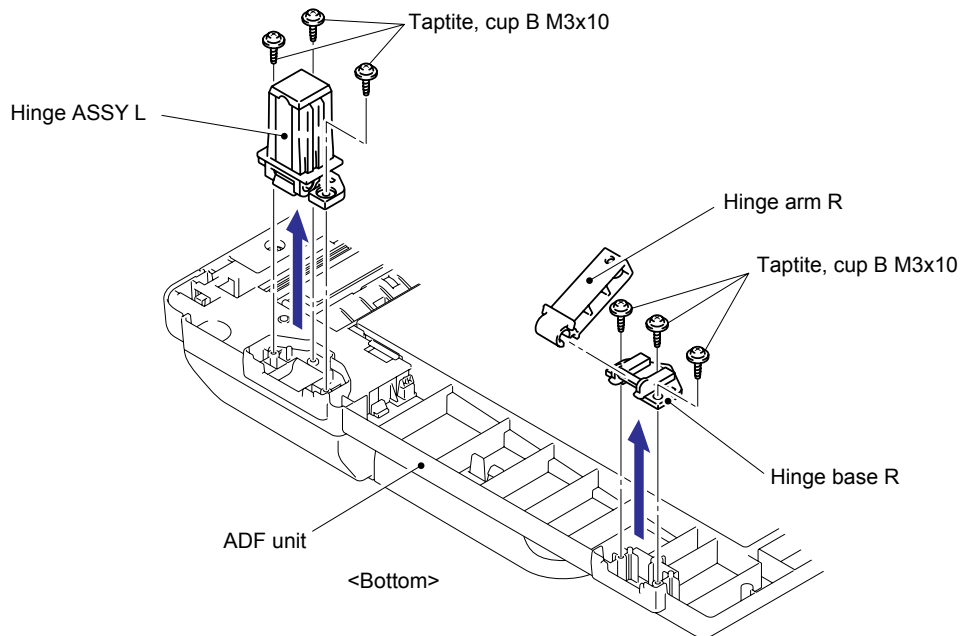

Fig. 3-59

- (5) Place the ADF unit the right way up.
- (6) Release the two Pins on both sides of ADF cover to remove it while the ADF cover being opened.

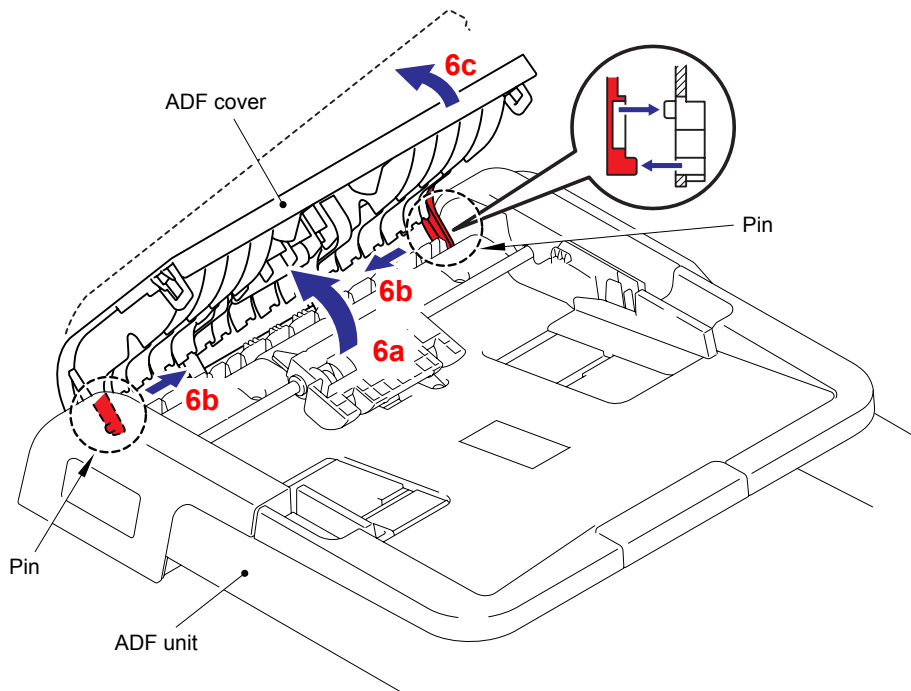
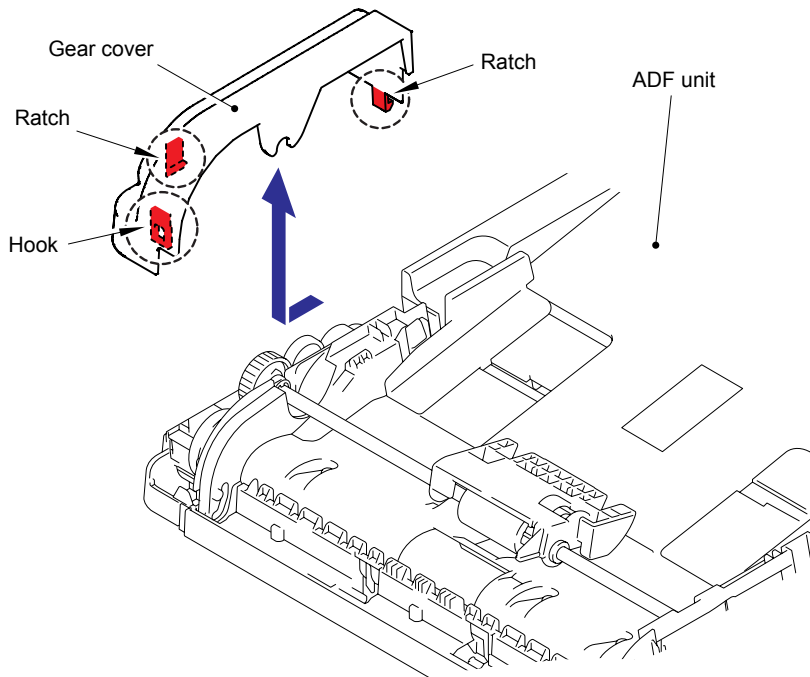

Fig. 3-60

- (7) Release the two Ratches and one Hook of the Gear cover from the back side of the ADF unit to remove it.



* Hook and Ratch positions of the back view of the ADF unit.

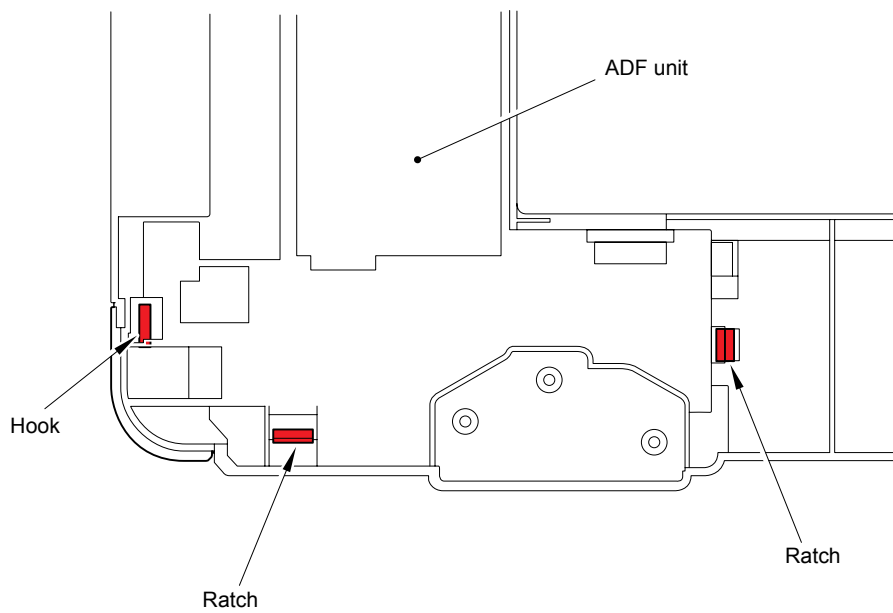

Fig. 3-61

- (8) Release the Rib from the ADF unit to remove the Separation roller shaft ASSY and Separation roller shaft bush.

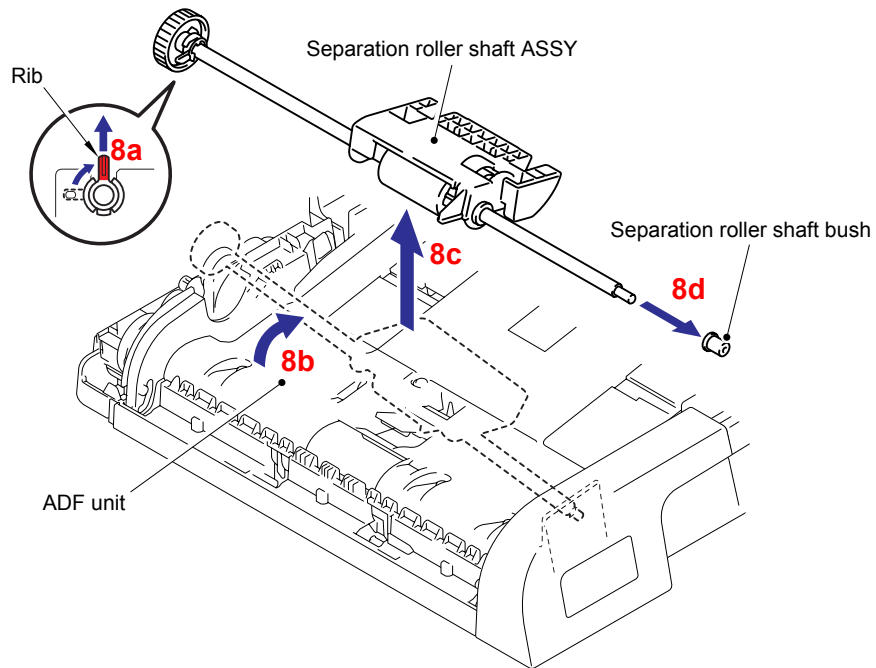

Fig. 3-62

- (9) Remove the two cup B M3x10 Taptite screws from the ADF front cover.
- (10) Release the two Pins and two Hooks to remove the ADF front cover from the ADF unit.

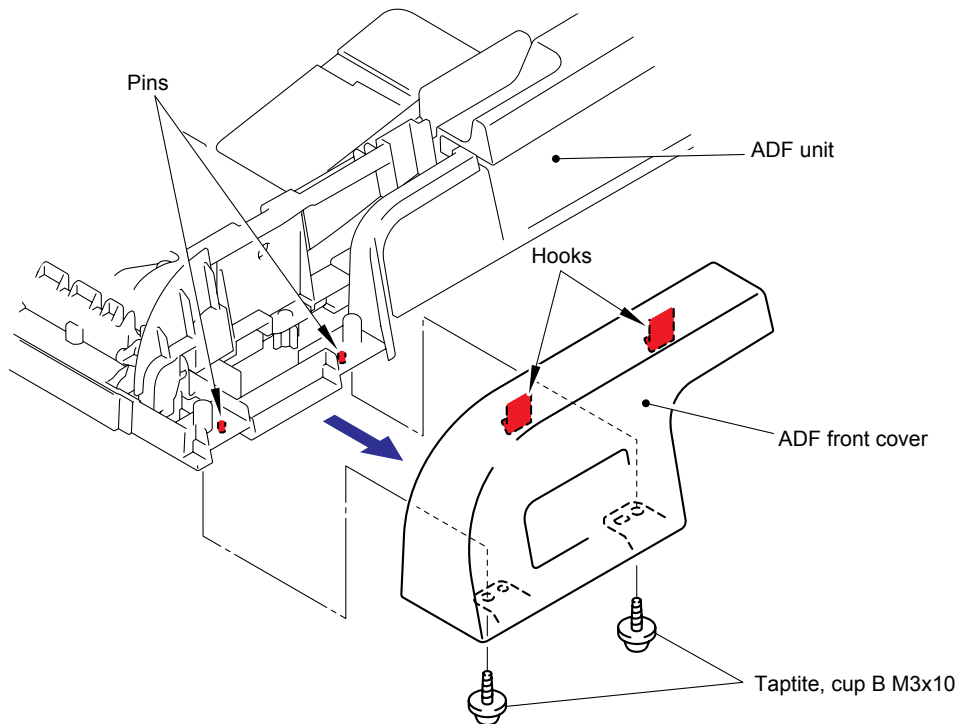

Fig. 3-63

(11) Remove the three cup B M3x10 Taptite screws, and then remove the ADF side cover.

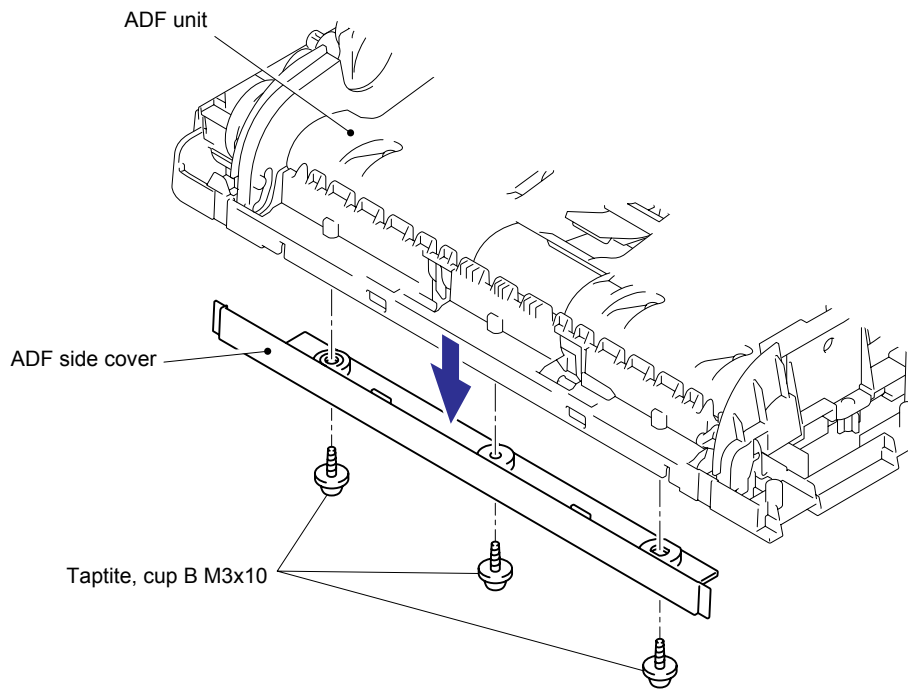

Fig. 3-64

(12) Remove the four cup B M3x10 Taptite screws from the Upper document chute.

(13) Release the three Hooks on the bottom of the Upper document chute to remove it.

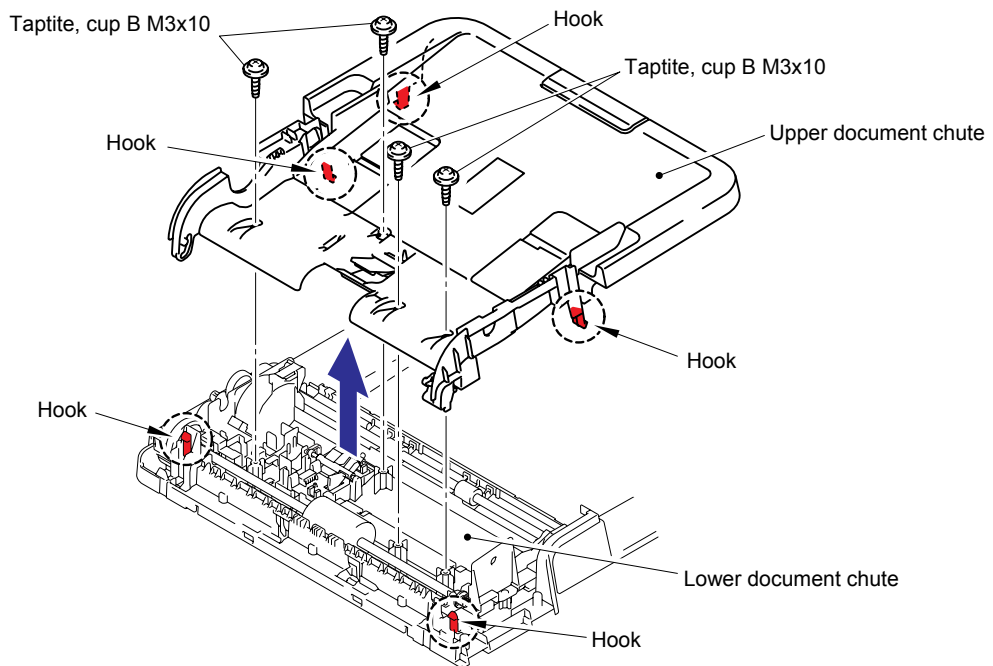

Fig. 3-65

(14) Remove the Separation rubber ASSY from the Upper document chute.

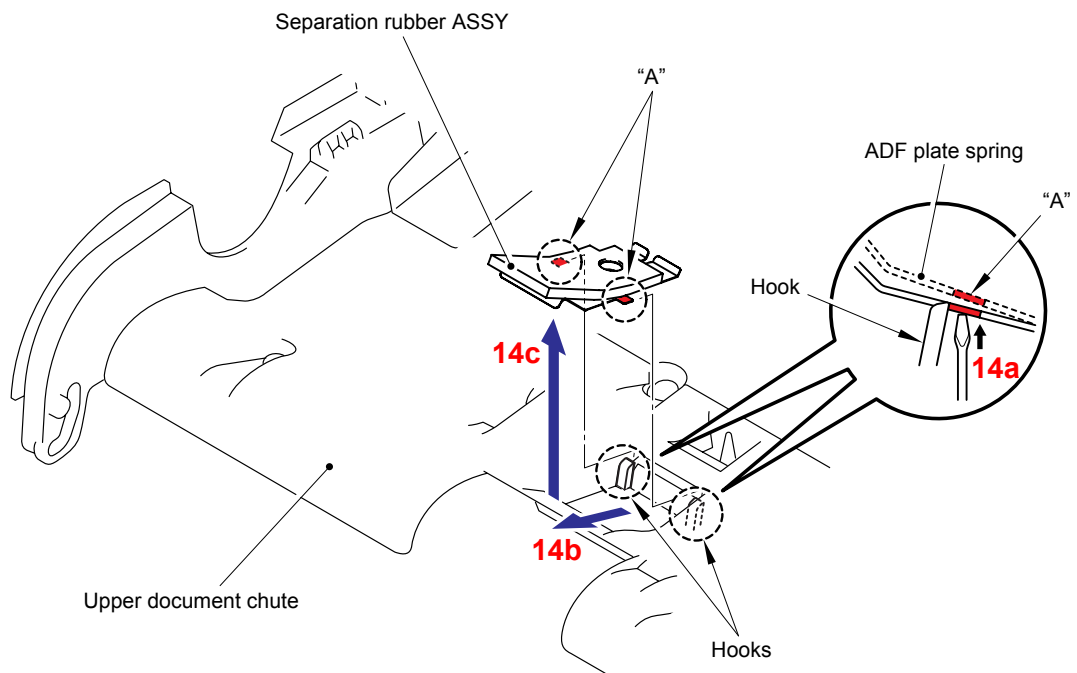

Fig. 3-66

(15) Remove the Separation rubber from the ADF plate spring.

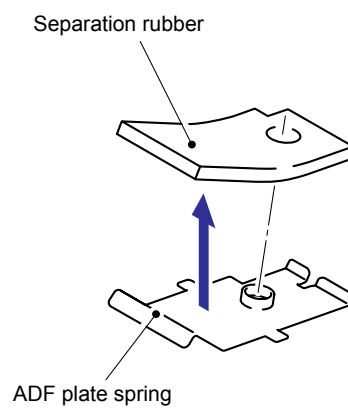

Fig. 3-67

- (16) Release the two Hooks to remove the Resin bush.
- (17) Remove the LF roller ASSY from the Lower document chute.

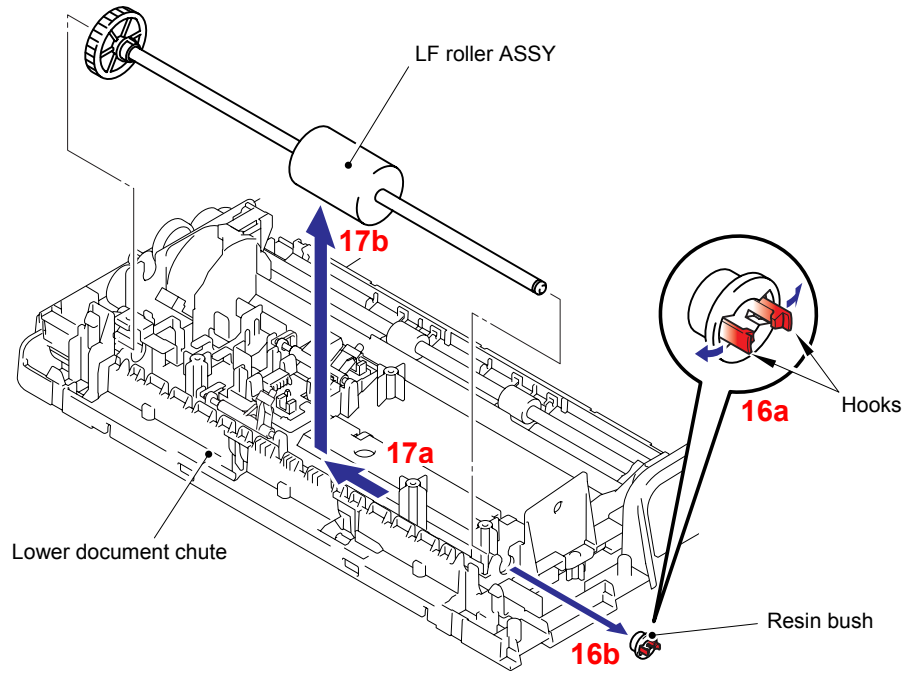

Fig. 3-68

- (18) Release the two Hooks A to remove the Ejection roller ASSY from the Lower document chute.
- (19) Release the two Hooks B to remove the Ejection roller bush from the Ejection roller ASSY.

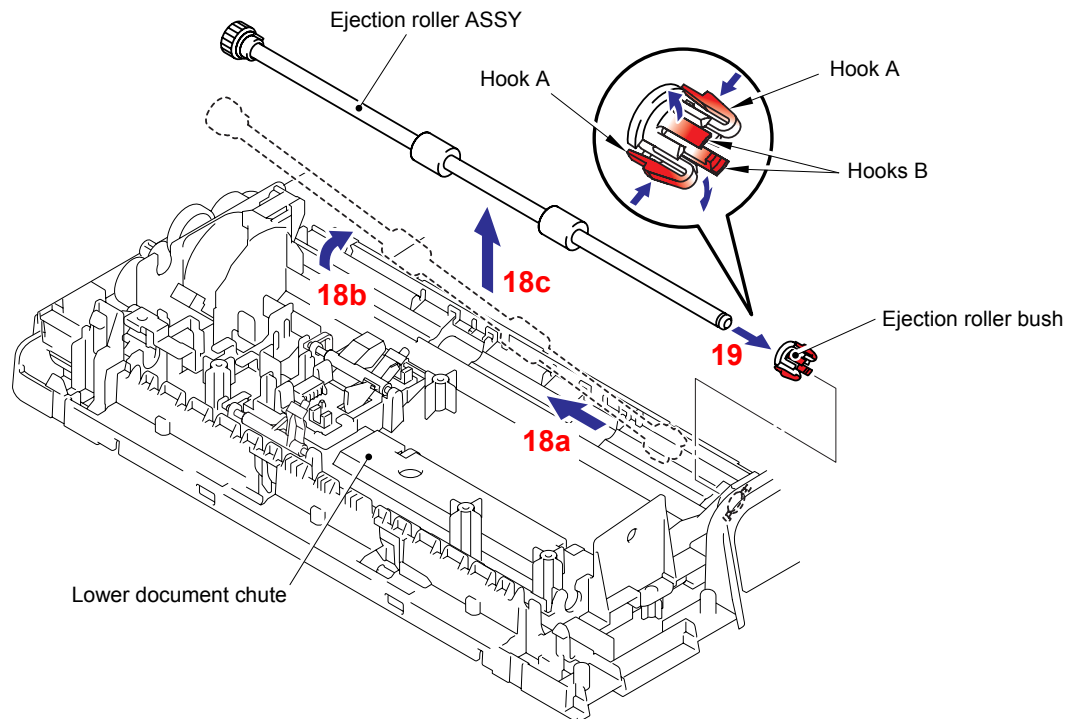

Fig. 3-69

(20) Remove the Document front actuator from the Lower document chute. By lifting up 20a and slide the actuator left (20b) then right and outwards (20c).

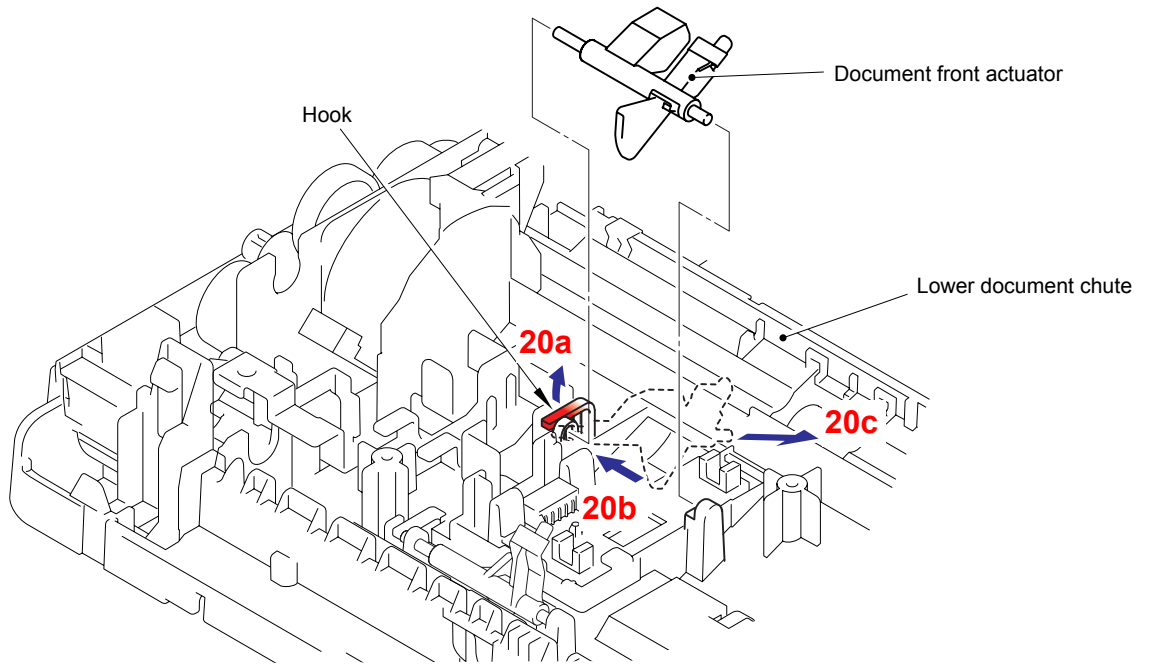

Fig. 3-70

(21) Remove the Document rear actuator from the Lower document chute. By lifting up 21a and slide the actuator left (21b) then right and outwards (21c).

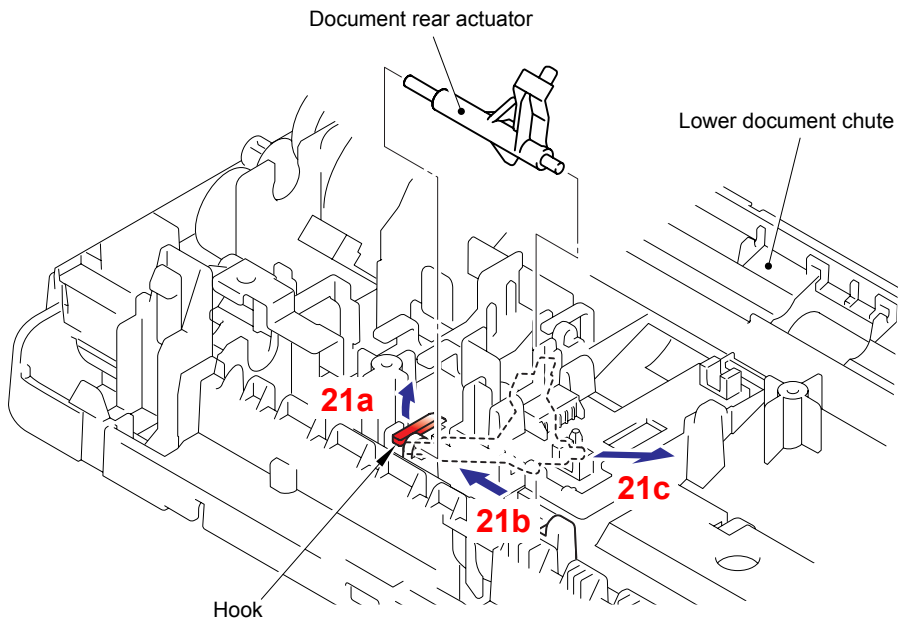

Fig. 3-71

- (22) Push holders (22a) to release the ADF sensor PCB and lift the PCB from under the two Hooks of the Lower document chute.
- (23) Disconnect the ADF sensor harness ASSY from the ADF sensor PCB.

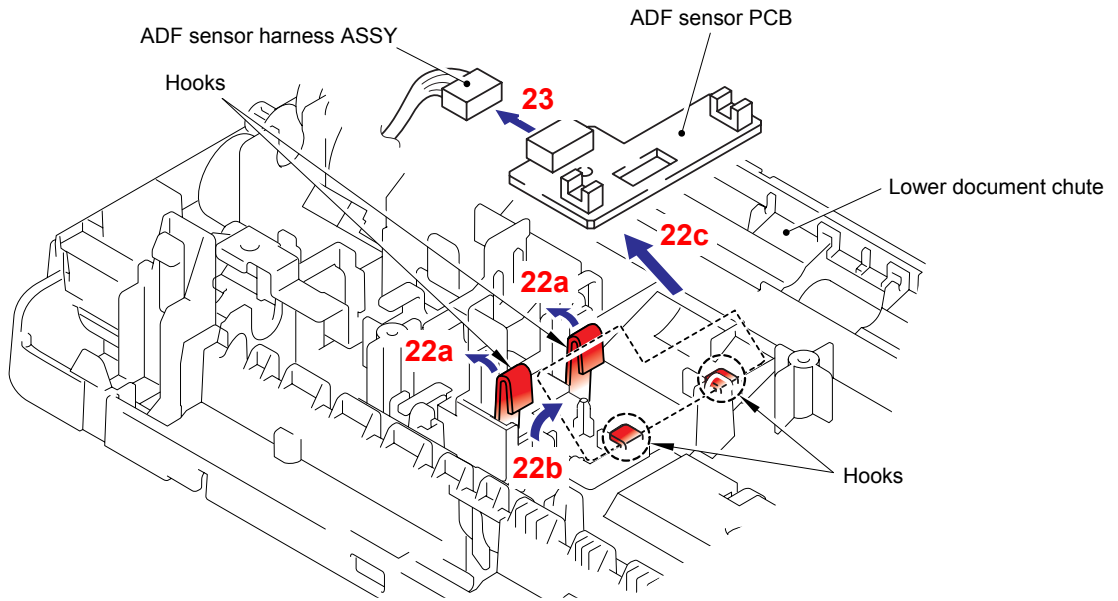

Fig. 3-72

- (24) Remove the ADF motor harness from the ADF motor.

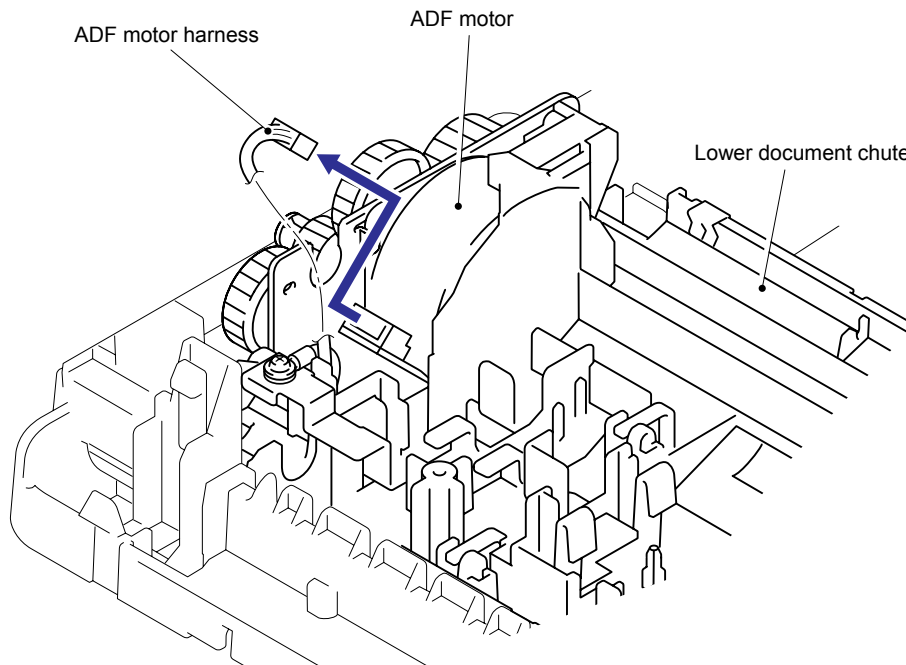

Fig. 3-73

- (25) Remove the two cup B M3x10 Taptite screws from the Lower document chute.
- (26) Remove the cup S M3x6 Taptite screw and FG harness ADF from the Lower document chute.

Note:

Be careful not to bend the metal frame if the screw is tight.

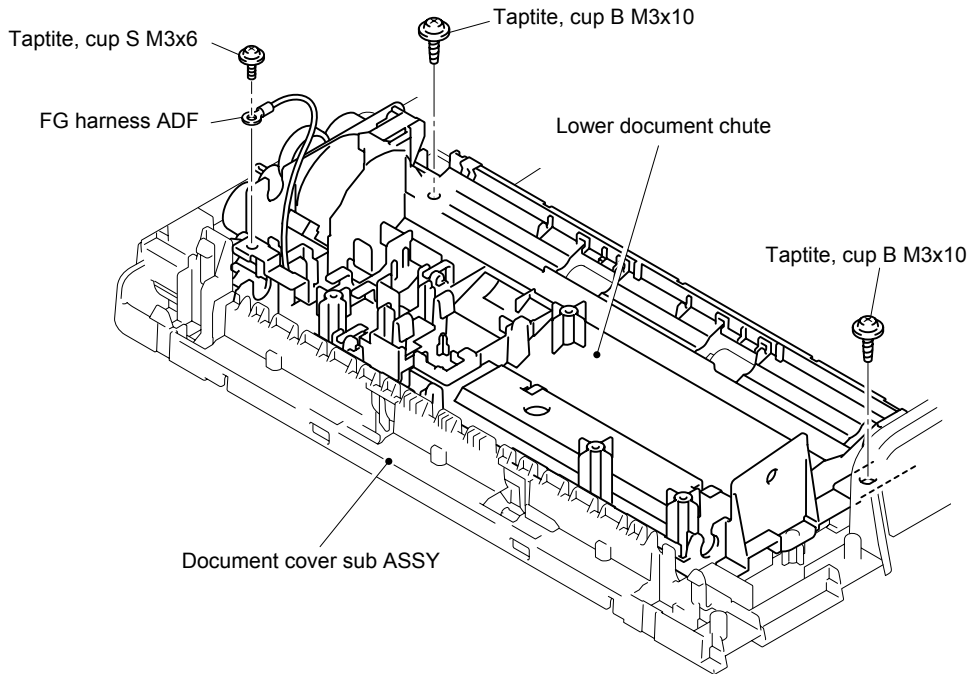

Fig. 3-74

(27) Remove the two cup B M3x10 Taptite screws while lifting up the Lower document chute slightly. Then, remove the Drive frame ASSY.

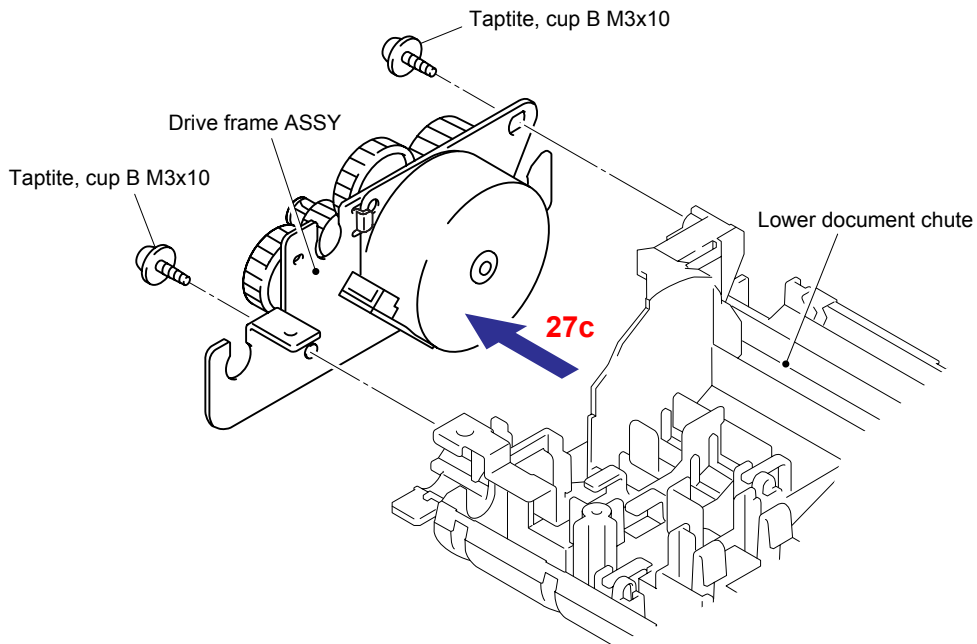
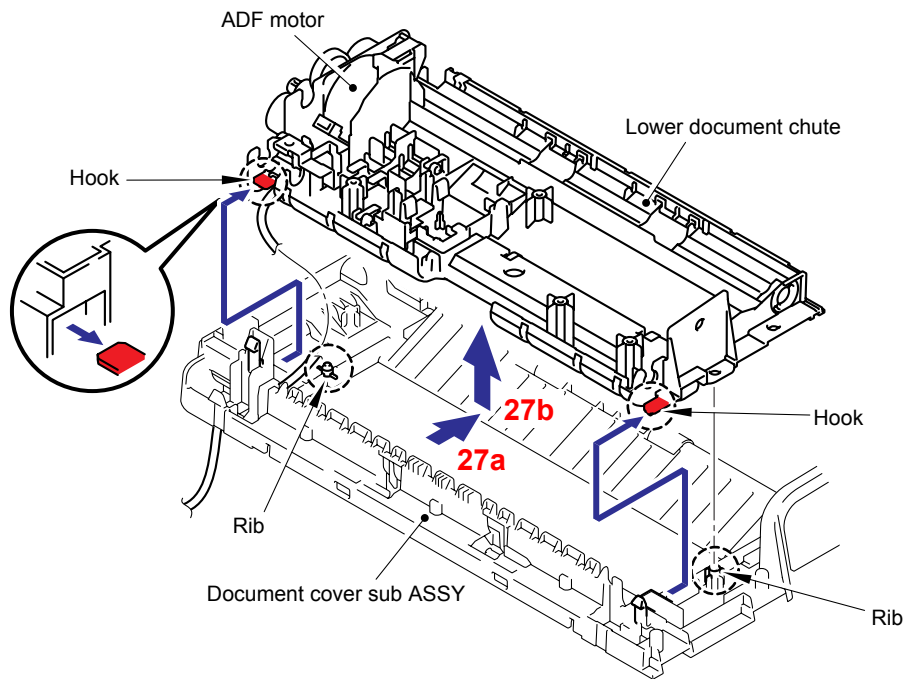

Fig. 3-75

(28) Remove the bind S M3x6 Taptite screw from the Drive frame ASSY and then remove the ADF motor.

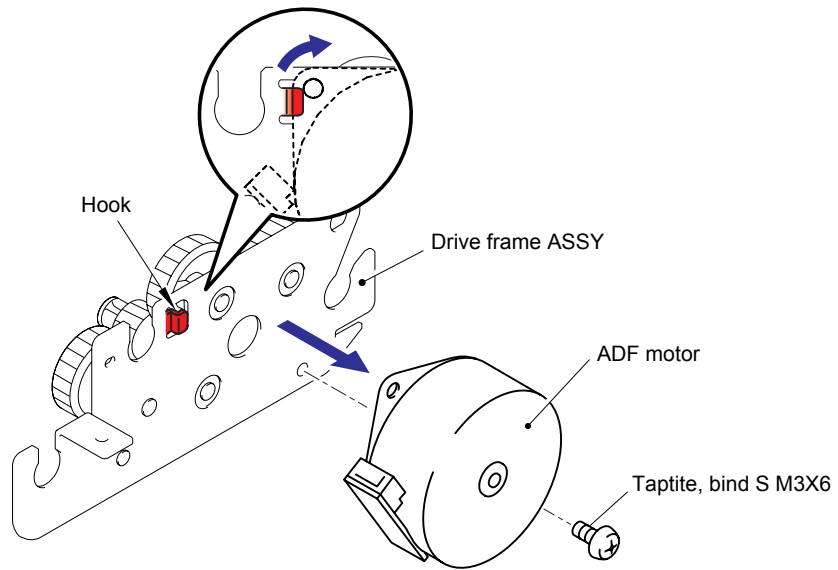

Fig. 3-76

(29) Release the two Pins from the Document cover sub ASSY to remove the Document stopper.

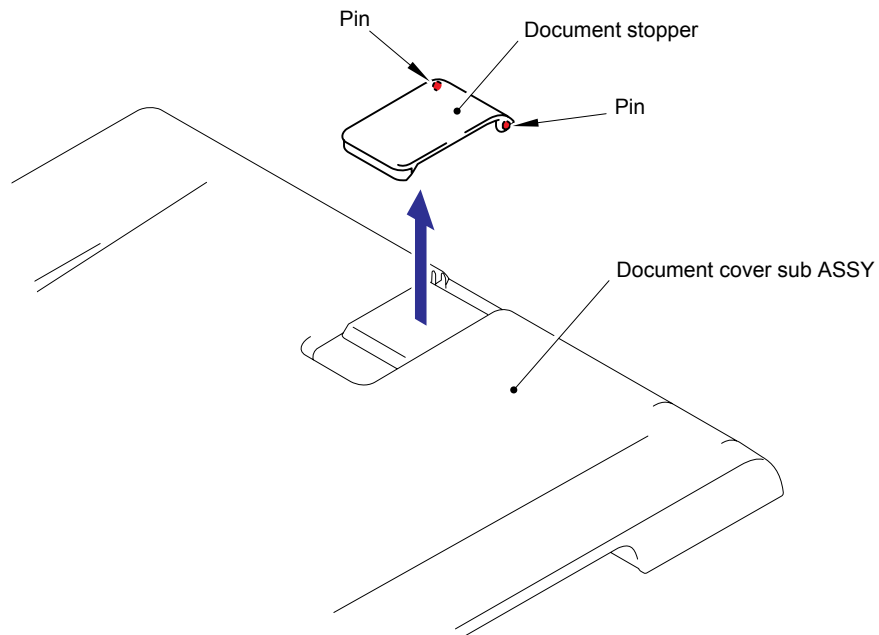

Fig. 3-77

(30) Remove the Harness holder and ADF harness ASSY from the Lower document chute.

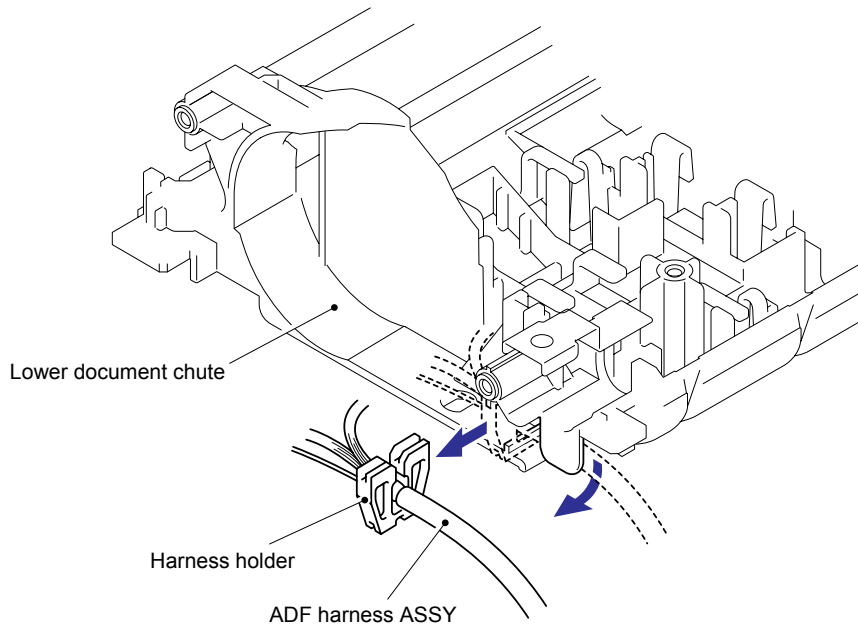

Fig. 3-78

(31) Turn the Lower document chute upside down.

(32) Release the two Pins of the Lower document chute to remove the Document hold ASSY and Document spring.

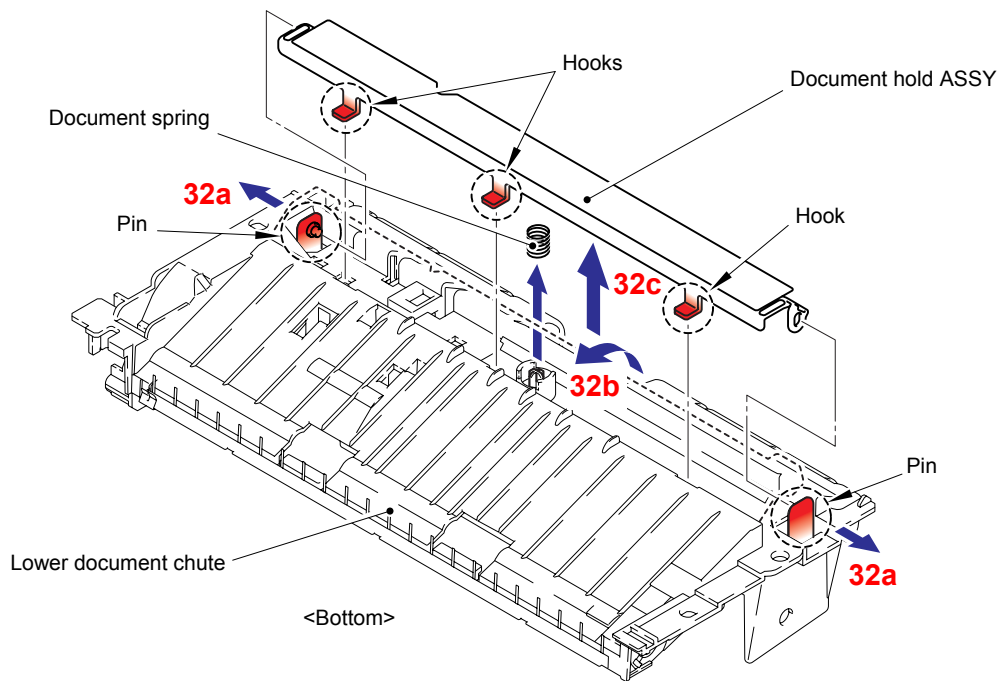

Fig. 3-79

(33) Only remove the Lower chute film from the Lower document chute if it is damaged and needs to be replaced with a new one.

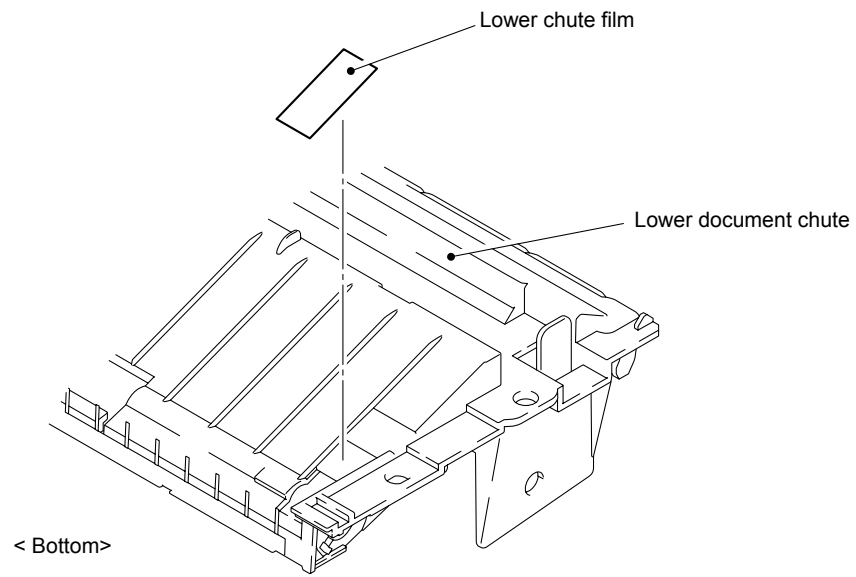

Fig. 3-80

8.20 Panel Unit

- (1) Release the eight Hooks to remove the Printed panel cover from the Document scanner unit.

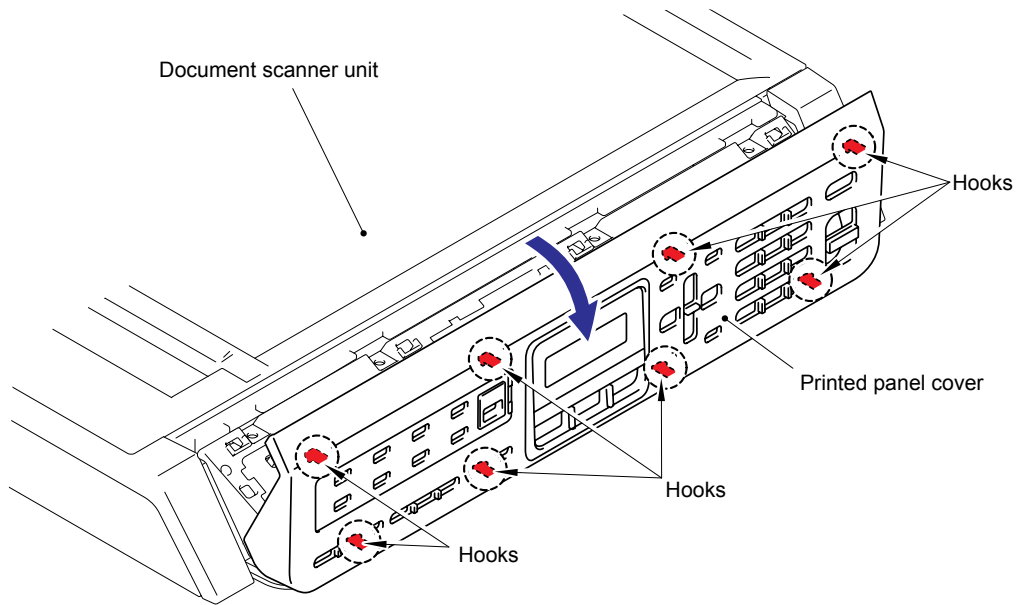

Fig. 3-81

- (2) Remove the four cup B M3x10 Taptite screws from the top side of the Panel unit and cup B M3x10 Taptite screw from the bottom.

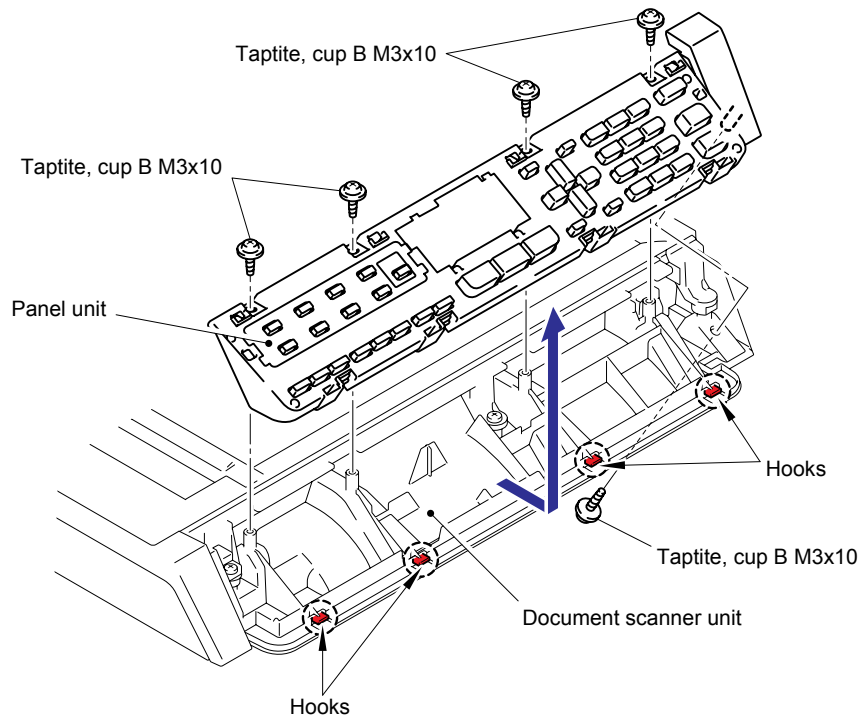

Fig. 3-82

- (3) Gently lift up the Panel unit slightly and disconnect the Connector (CN2) from the Panel PCB ASSY.

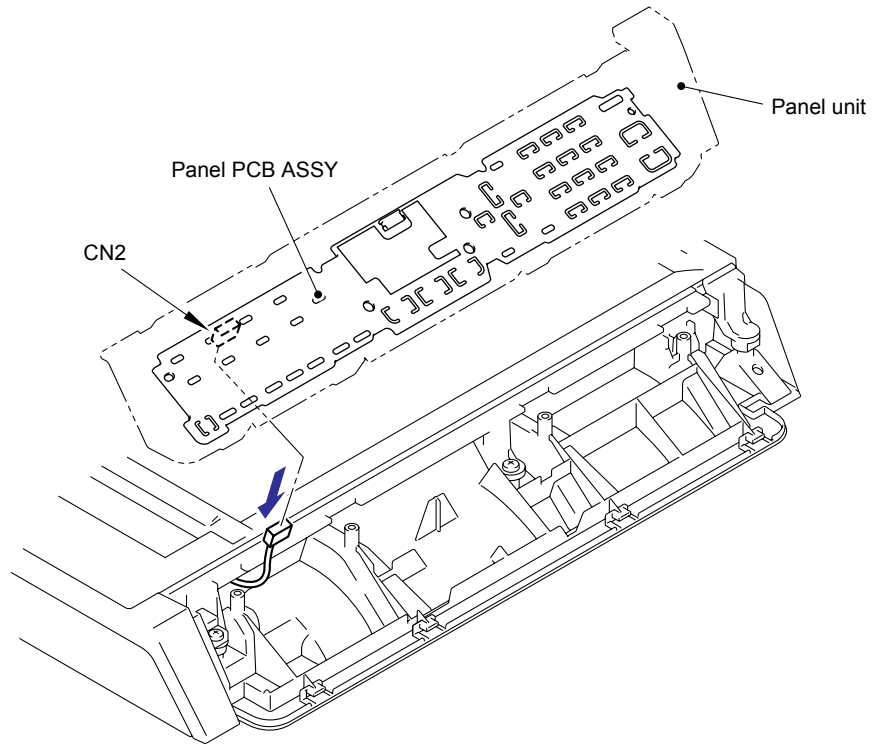

Fig. 3-83

- (4) Turn the Panel unit upside down and disconnect the Connector (CN3) from the Panel PCB ASSY.

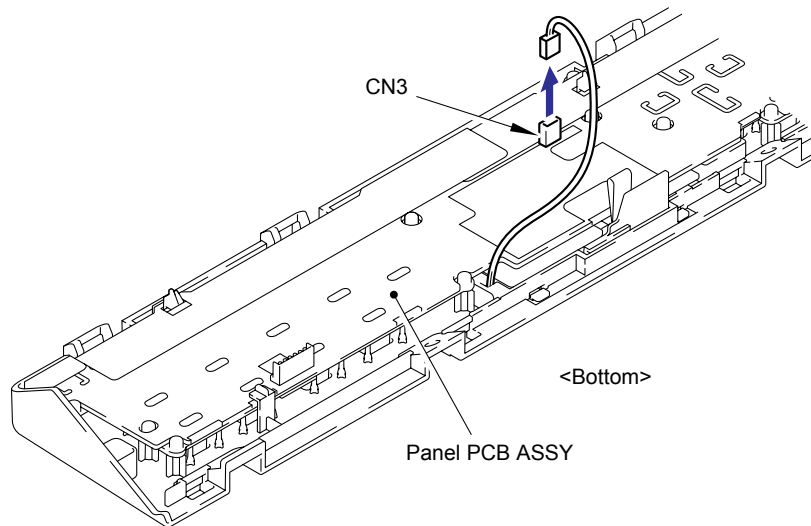

Fig. 3-84

- (5) Remove the Panel insulation sheet L and R.
- (6) Release the three Hooks to remove the Panel PCB ASSY from the Panel unit.
- (7) Release the Locks for the Connector (CN1) provided on the Panel PCB ASSY and disconnect the FC harness.

Note:

- After disconnecting the flat cable(s), check that each cable is not damaged at its end or short-circuited.
- When connecting the flat cable(s), do not insert it at an angle. After insertion, check that the cable is not at an angle.

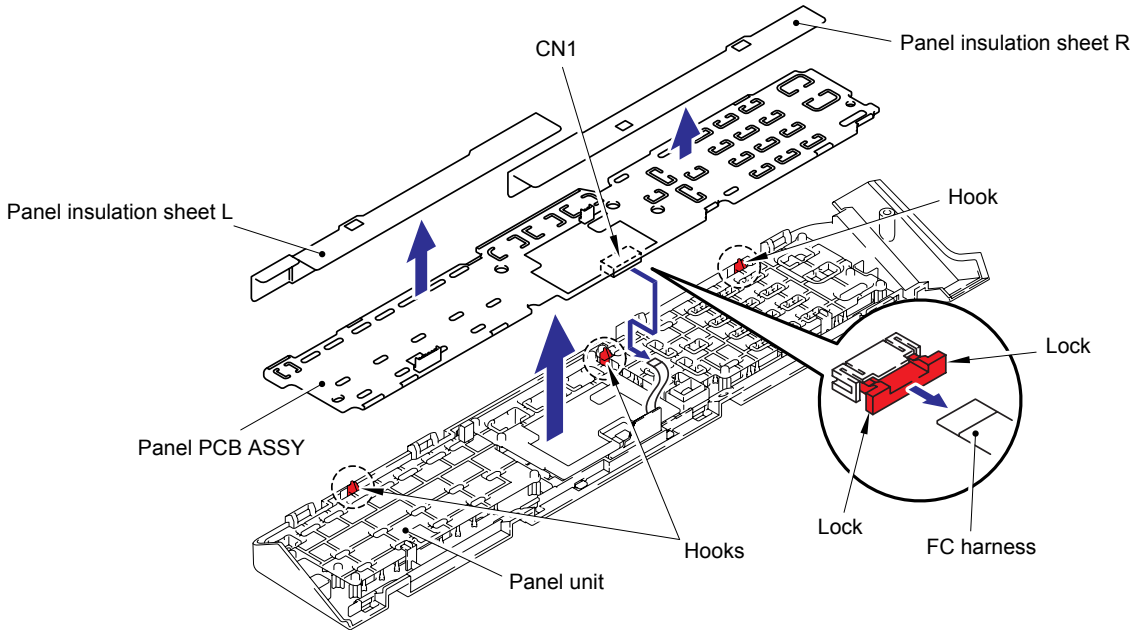

Fig. 3-85

- (8) Remove the Rubber key (R, C, L) from the Panel unit.

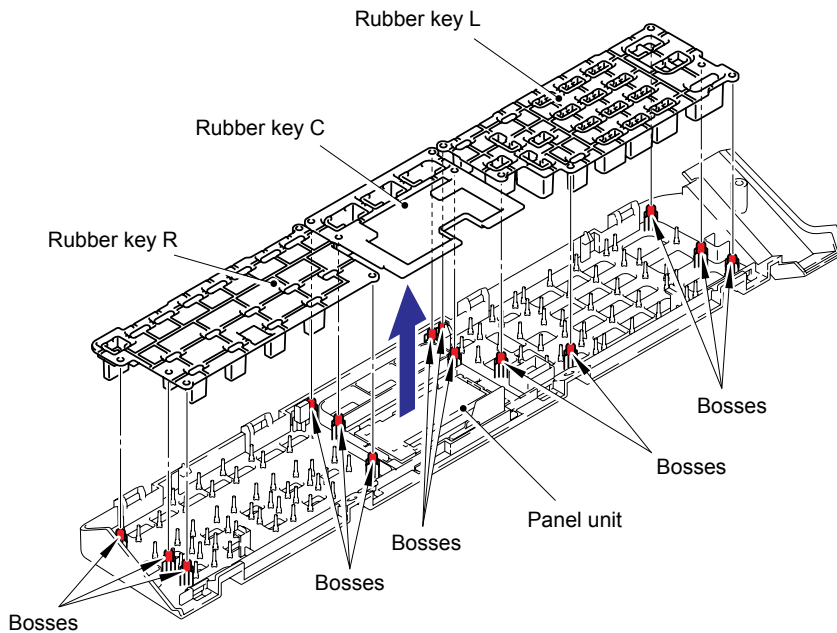

Fig. 3-86

(9) Remove the LCD protective film.

(10) Release the two Hook A to remove the LCD cover and LCD holder from the Panel cover.

Note:

Be careful not to loose the LED guide.

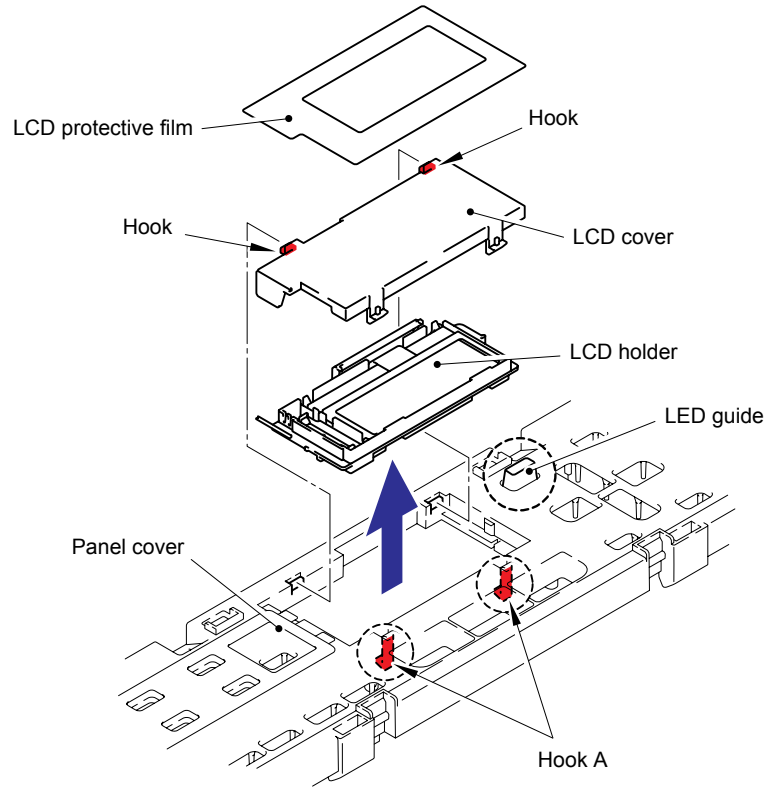

Fig. 3-87

(11) Release the three Hooks to remove the LCD from the Backlight module.

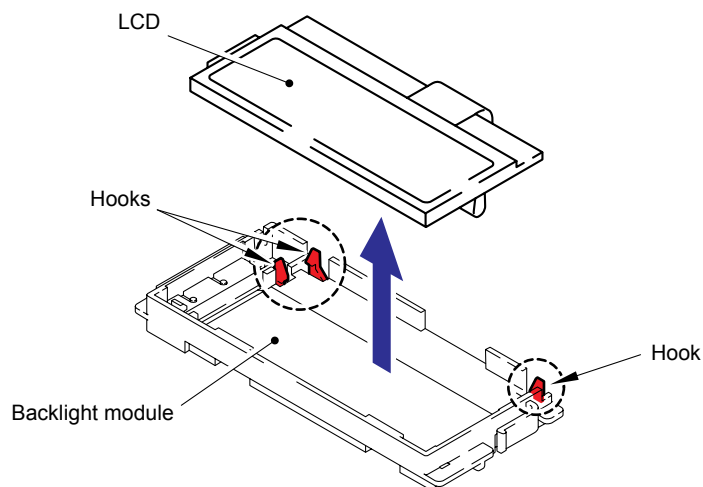

Fig. 3-88

8.21 NCU PCB ASSY (MFC-9440CN/ 9450CDN only)

- (1) Remove the four cup B M3x8 Taptite screws, and then remove the NCU cover from the Joint cover ASSY.

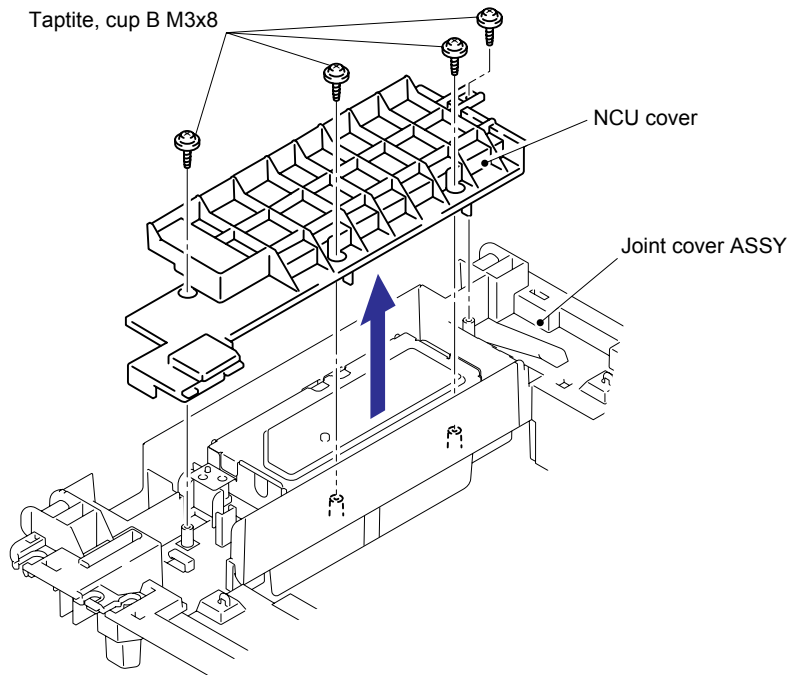

Fig. 3-89

- (2) Remove the two bind B M4x12 Taptite screws from the NCU unit. Remove the Screw pan (S/P washer) M3.5x6, and then remove the FG harness NCU.
- (3) Remove the NCU unit from the Joint cover ASSY.

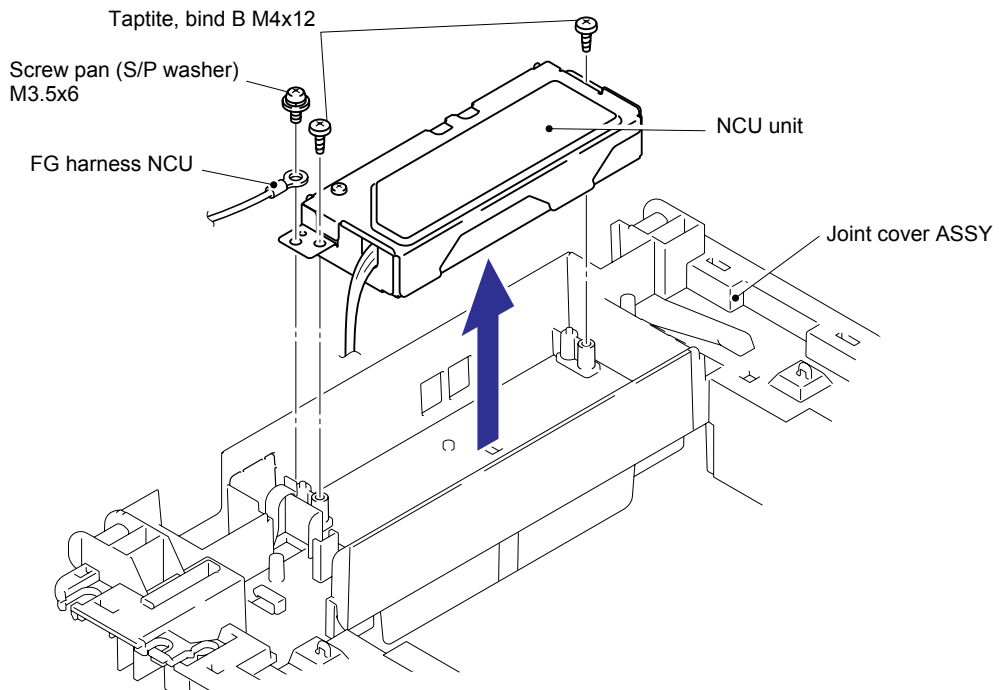

Fig. 3-90

- (4) Remove the Screw pan (S/P washer) M3.5x6 from the NCU shield cover, and then remove the NCU shield plate.

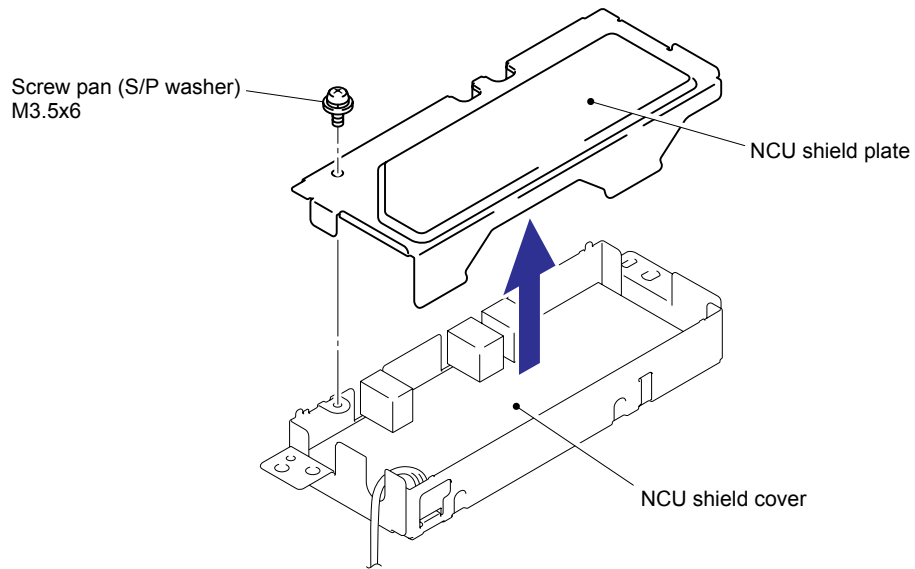

Fig. 3-91

- (5) Disconnect the NCU harness ASSY.
- (6) Remove the two cup S M3x6 Taptite screws from the NCU shield cover, and then remove the NCU PCB ASSY.

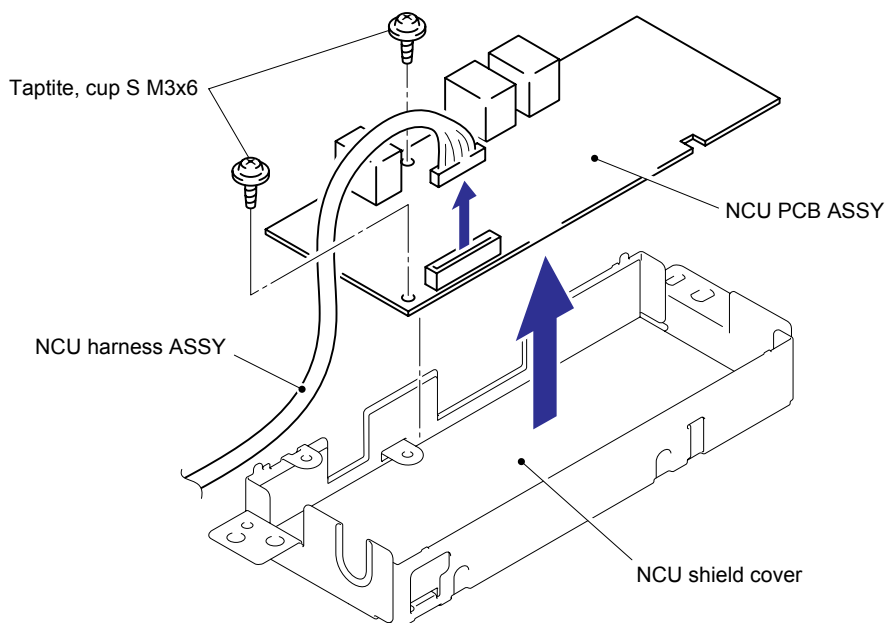

Fig. 3-92

8.22 Joint Cover ASSY

- (1) Release the Hook (1a) to remove the Battery from the Joint cover ASSY.
- (2) Disconnect the connector from the Battery.

Caution:

- There is danger of explosion if the battery is incorrectly replaced.
- Do not disassemble or recharge the battery.
- Do not dispose of the battery in fire.
- Used batteries should be disposed according to the local regulations.

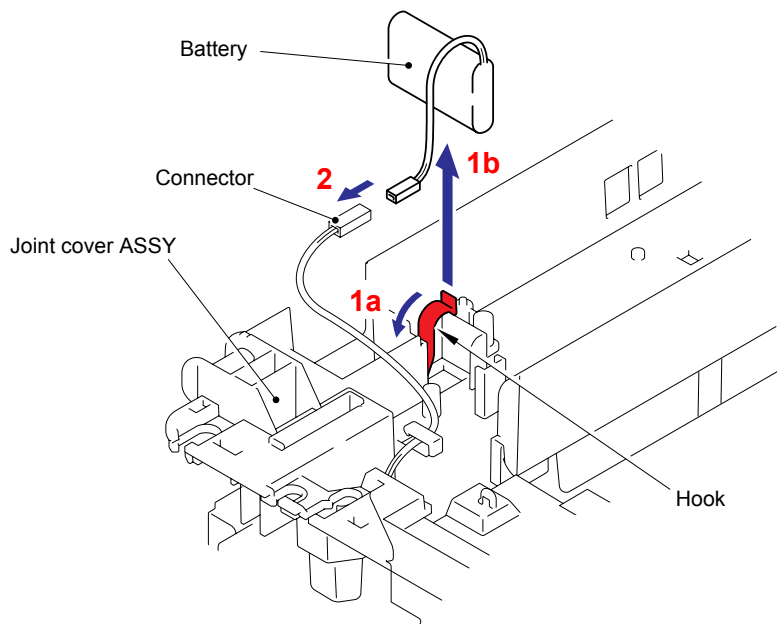

Fig. 3-93

- (3) Remove the Pull arm stopper. Then, remove the Pull arm guides L and R from the Joint cover ASSY.

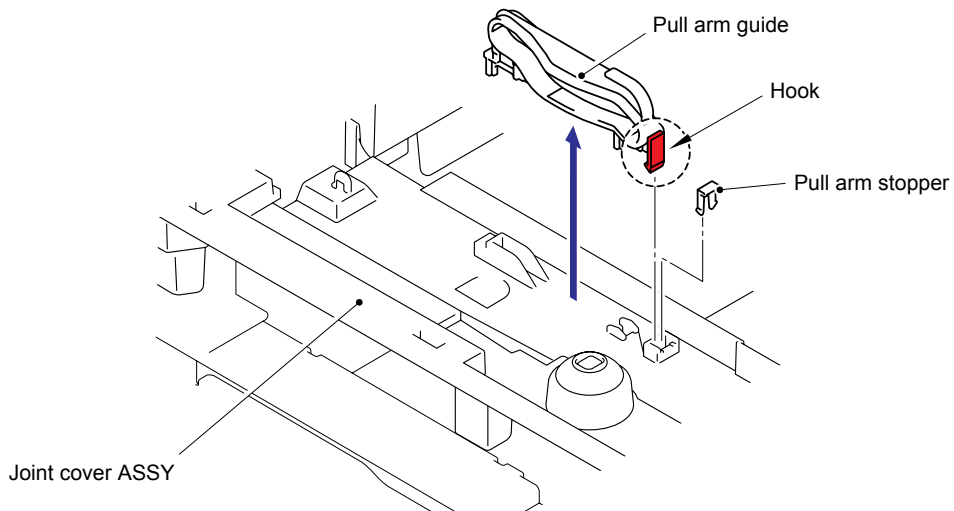

Fig. 3-94

- (4) Remove the cup S M3x8 Taptite screw from the Joint sub cover.
- (5) Release the two Hooks to remove the Joint sub cover from the Joint cover ASSY.

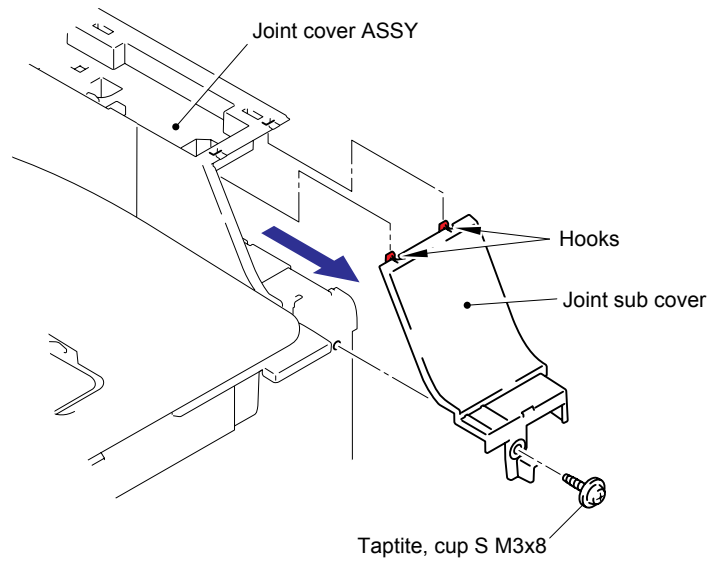

Fig. 3-95

- (6) Disconnect the three Connectors (CN3, CN7, CN10) from the Main PCB ASSY. (CN3, CN7: MFC-9440CN/ 9450CDN only)

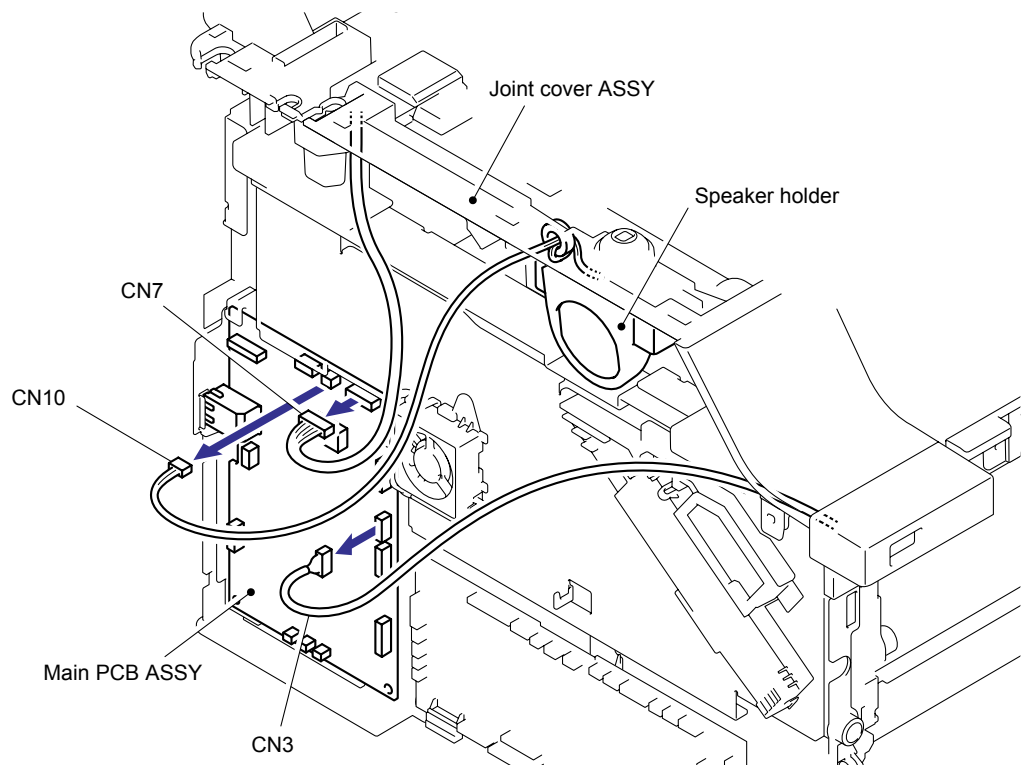

Fig. 3-96

- (7) Remove the three cup S M3x6 Taptite screws from the front side of the Joint cover ASSY, and remove two cup S M3x8 Taptite screws from the left side.

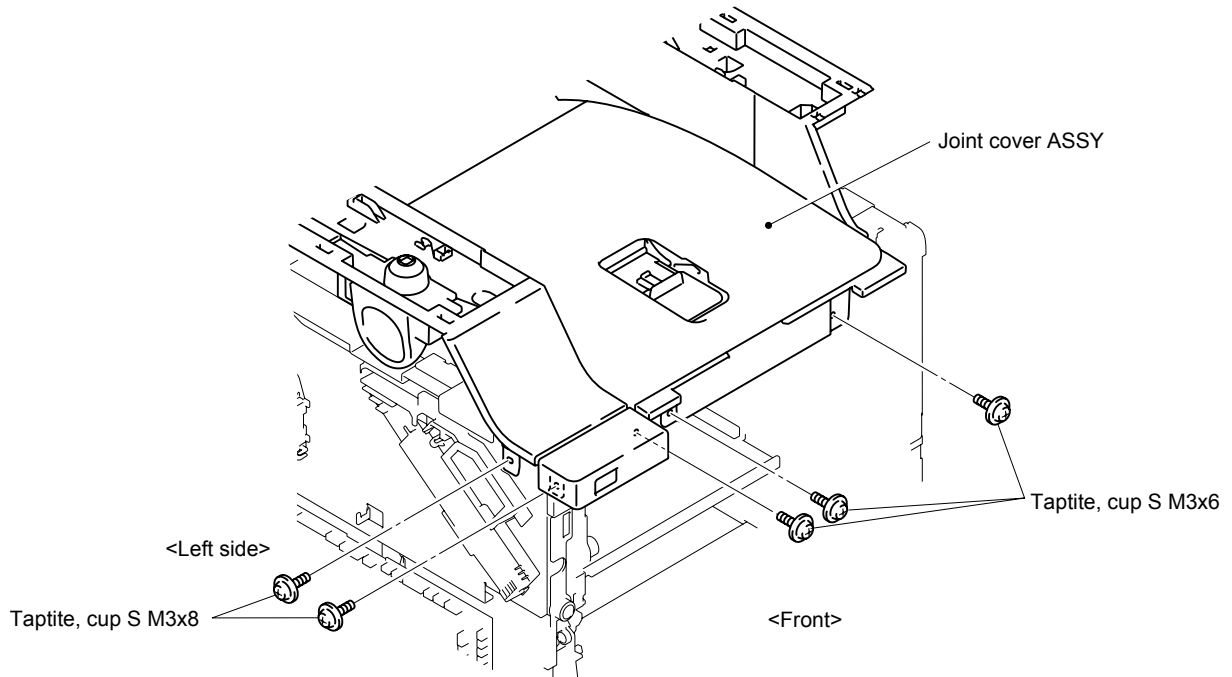

Fig. 3-97

- (8) Remove the three cup S M3x6 Taptite screws from the back side of the Joint cover ASSY.

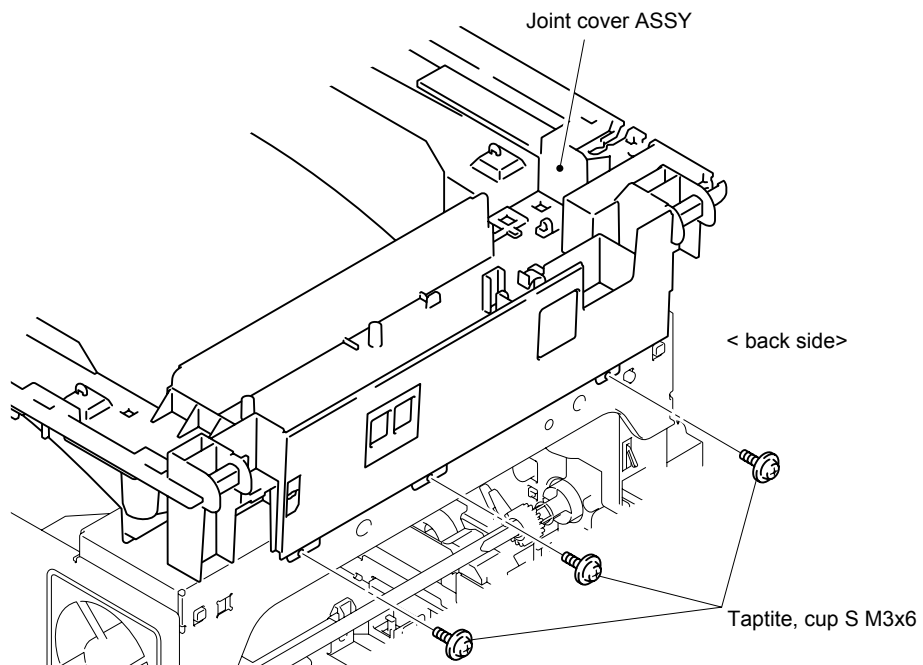

Fig. 3-98

- (9) Remove the six cup S M4x8 Taptite screws from the top of the Joint cover ASSY, and then release the Pin to remove the Joint cover ASSY from the Frame unit.

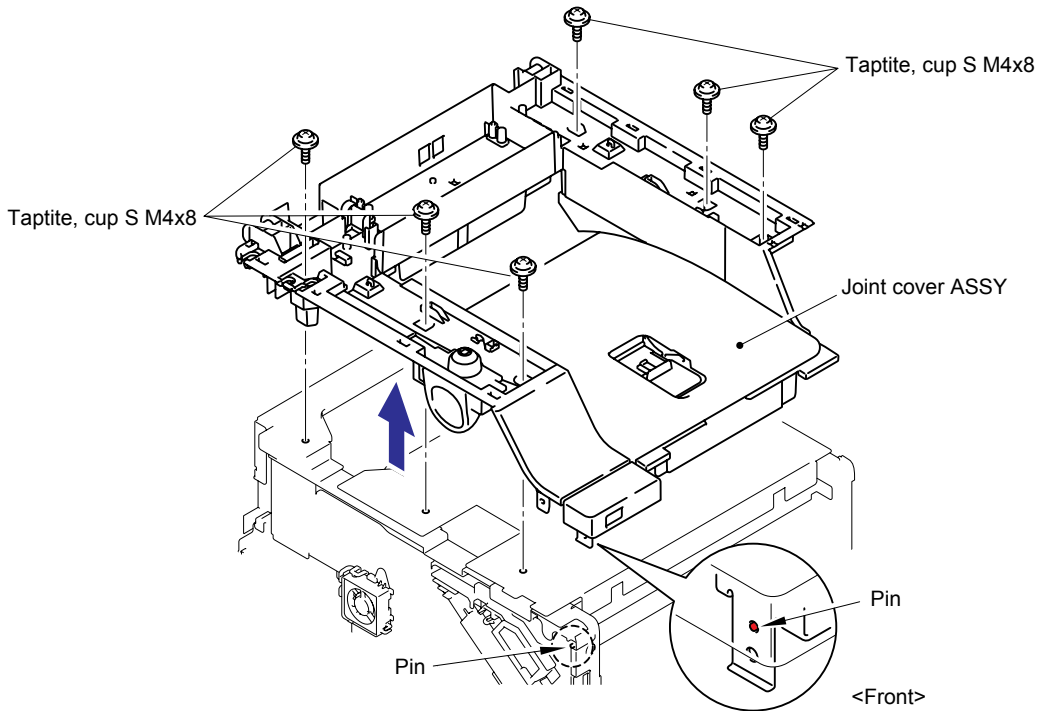

Fig. 3-99

- (10) Turn the Joint cover ASSY upside down.
- (11) Remove the Core which is bound with the Speaker harness from the Core holder.
- (12) Remove the two bind B M4x12 Taptite screws, and then remove the Speaker holder from the Joint cover ASSY.

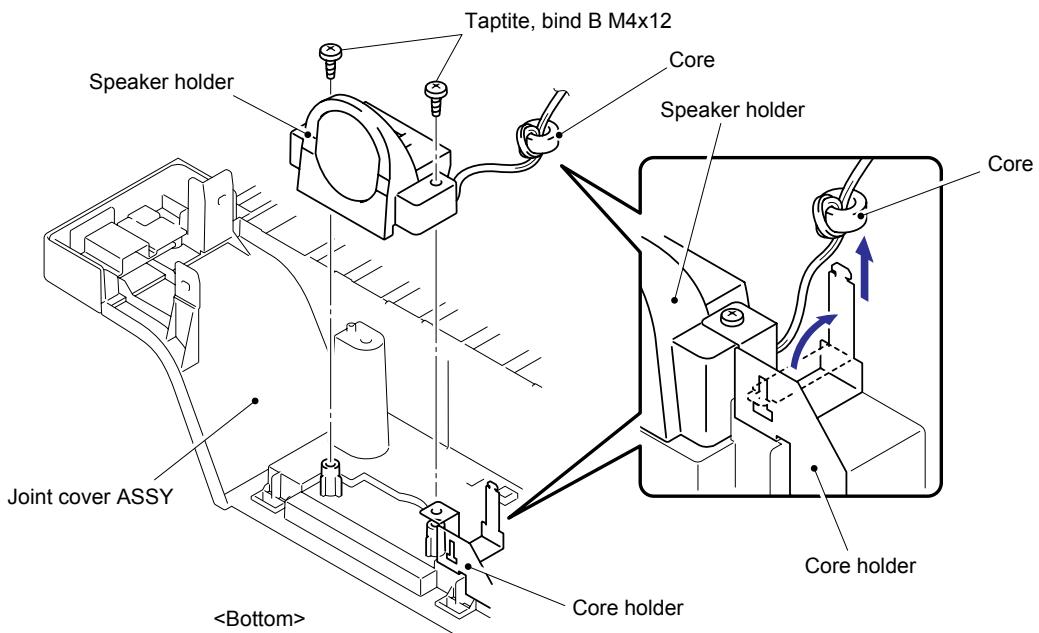

Fig. 3-100

- (13) Release the Hook to remove the Speaker hold spring from the Speaker holder.
- (14) Remove the Speaker ASSY from the Speaker holder.

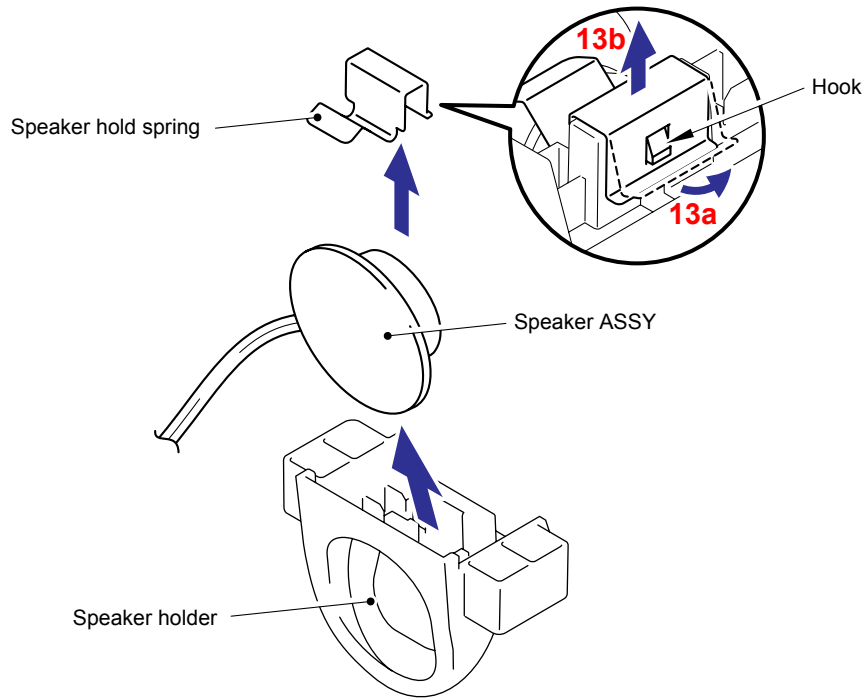

Fig. 3-101

- (15) Remove the three bind B M3x8 Taptite screws, and then remove the Top cover USB front ASSY.

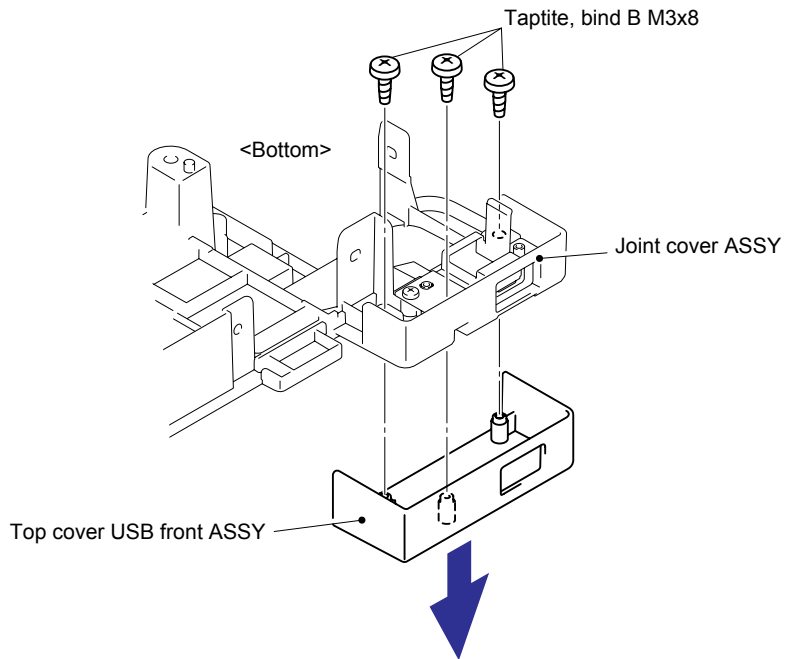

Fig. 3-102

(16) Remove the three bind B M3x8 Taptite screws, and then remove the USB holder and USB host relay PCB ASSY (MFC-9440CN/ 9450CDN only).

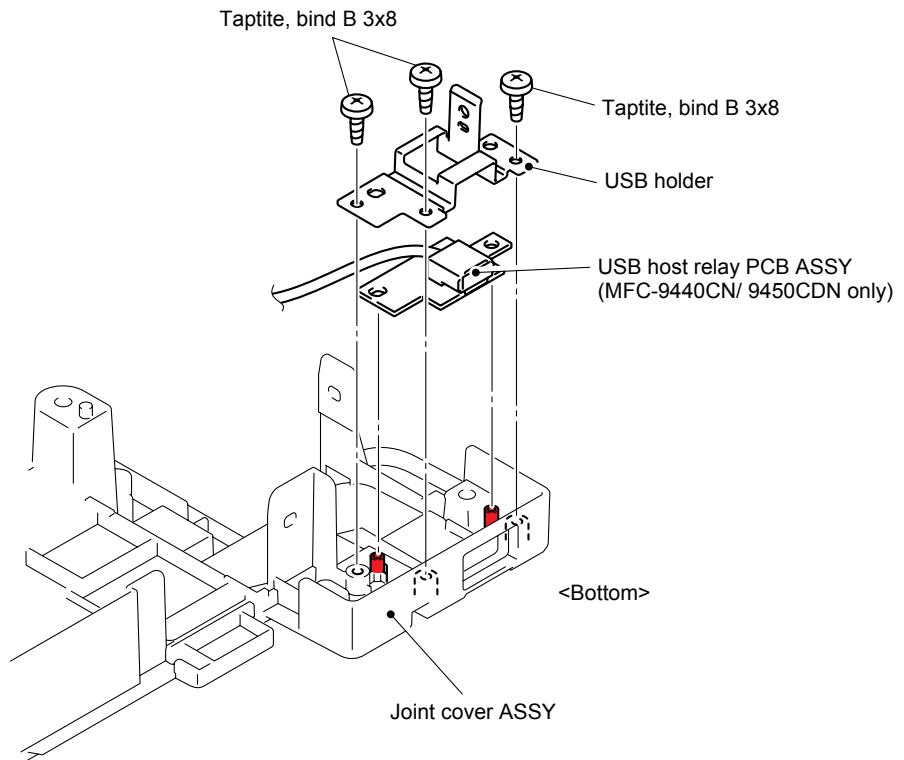

Fig. 3-103

(17) Disconnect the Main USB host harness ASSY from the USB host relay PCB ASSY. (MFC-9440CN/ 9450CDN only)

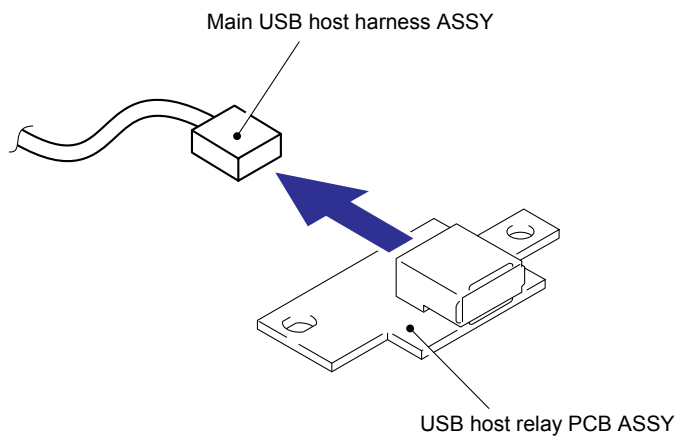

Fig. 3-104

(18) Release the Hook 1 (18a) to remove the Paper stopper guide from the Paper chute.

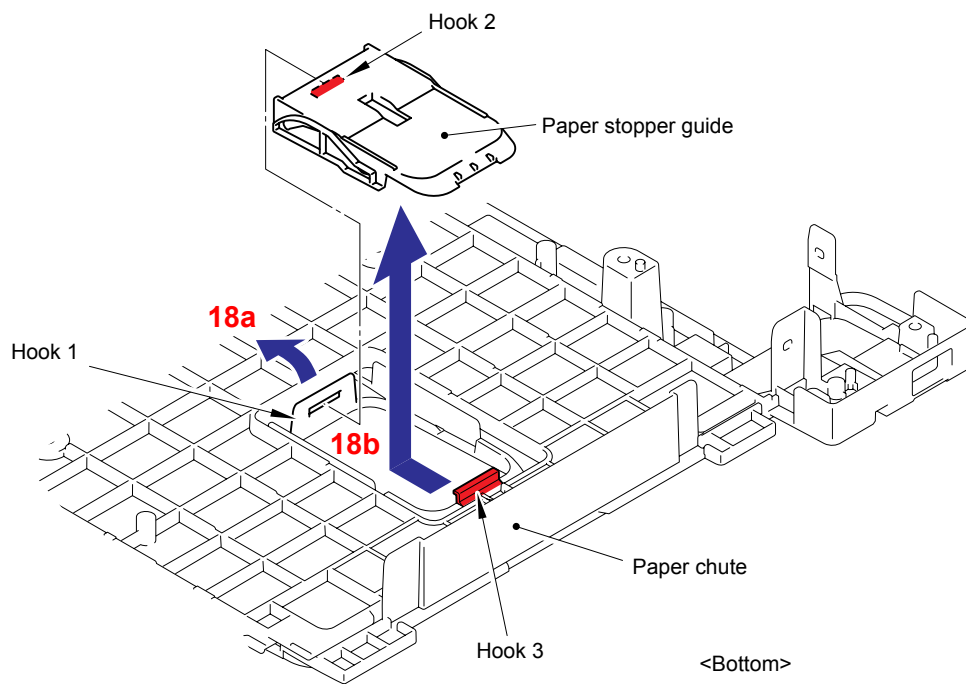

Fig. 3-105

(19) Remove the two cup B M3x8 Taptite screws, and then remove the Paper chute from the Joint cover ASSY.

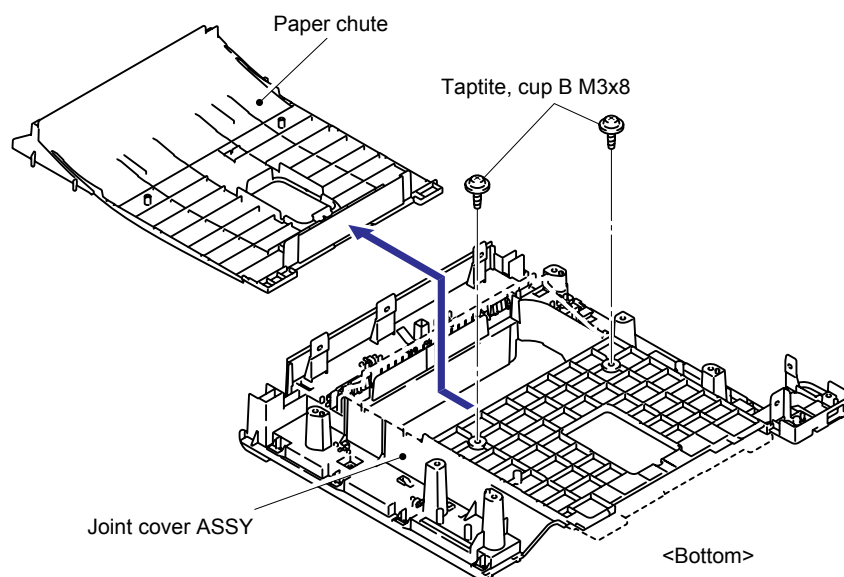

Fig. 3-106

(20) Remove the two cup B M3x6 Taptite screws, and then remove the Stack lever holder L, R from the Joint cover ASSY.

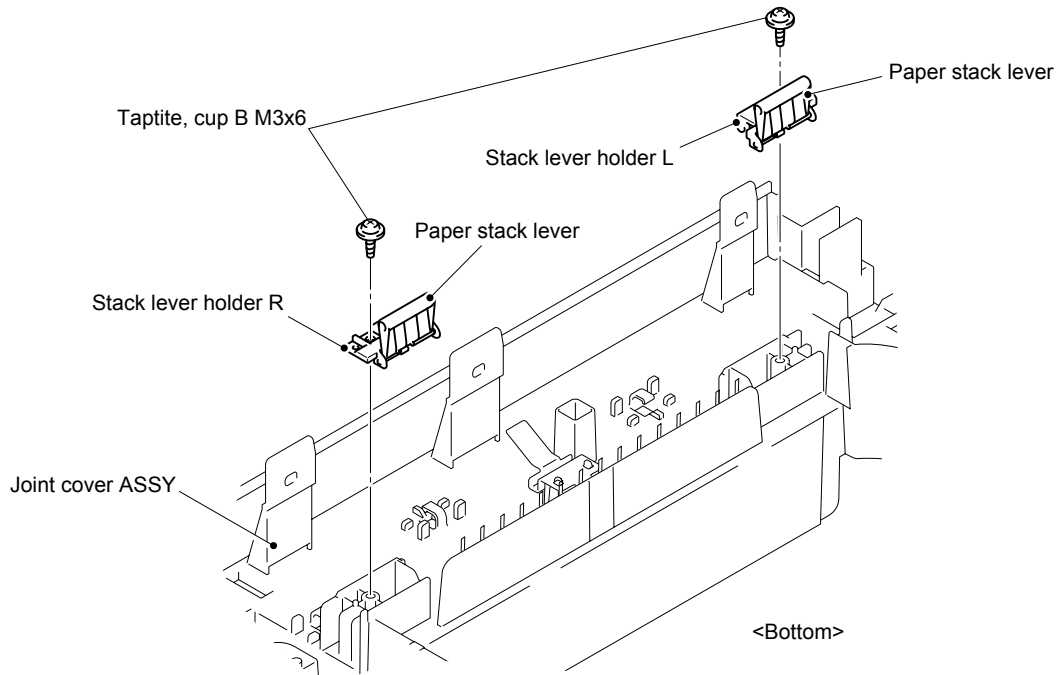

Fig. 3-107

(21) Release the two Pins to remove the Paper stack lever from the Stack lever holder R.

(22) Remove the Paper stack lever from the Stack lever holder L in the same way.

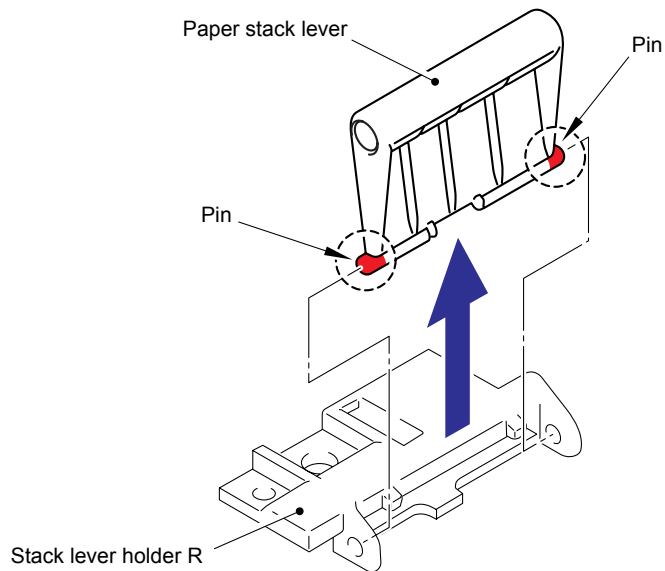

Fig. 3-108

- (23) Remove the bind B M3x8 Taptite screw, and then remove the Earth spring from the Joint cover ASSY.
- (24) Only if required and replacing with a new one remove the Antistatic brush from the Joint cover ASSY.

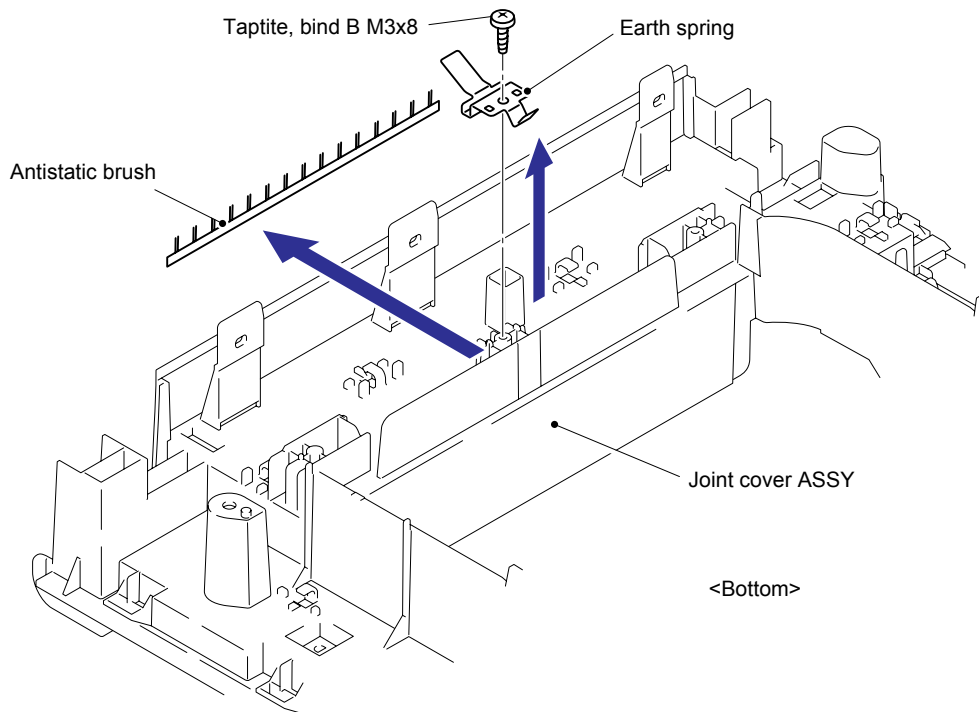

Fig. 3-109

8.23 Roller Holder ASSY

- (1) Push the Lift arm to the direction of the arrow 1a and release the boss of the Roller holder ASSY. Then, turn the Roller holder ASSY to the direction of the arrow 1b.

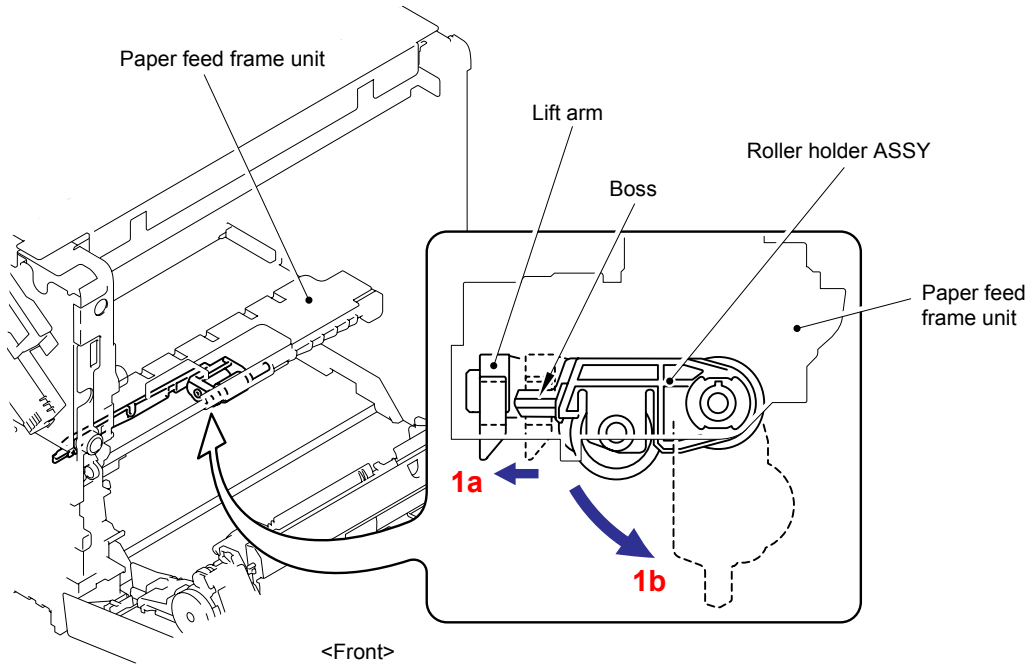

Fig. 3-110

- (2) Slide the Roller holder ASSY to the direction of the arrows 2a, 2b and 2c in this order and remove it.

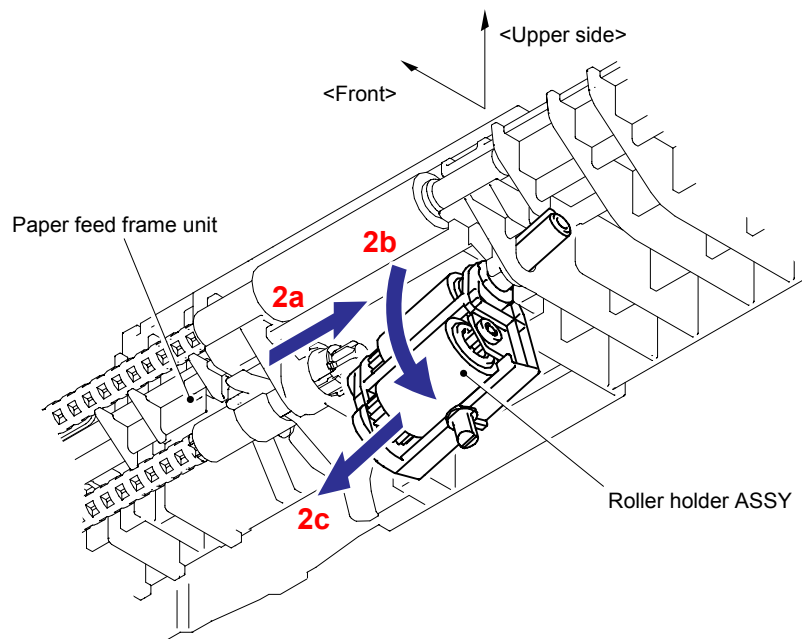

Fig. 3-111

8.24 Paper Feed Frame Unit/ T1 PE/Edge Sensor PCB ASSY

- (1) Disconnect the three connectors (CN1, CN10, CN11) from Engine PCB ASSY.

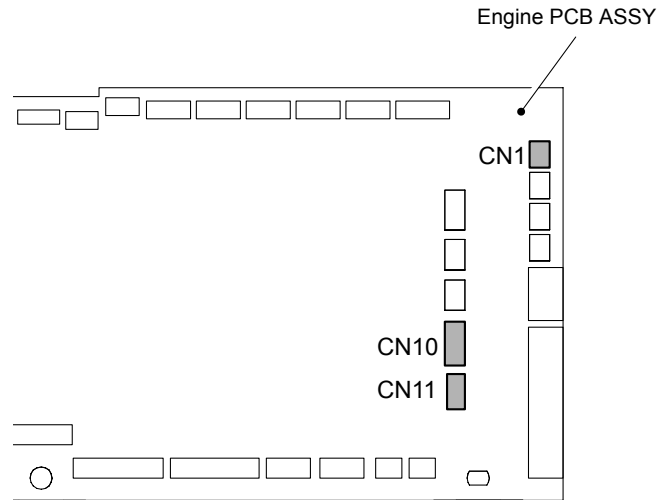

Fig. 3-112

- (2) Close the Front door unit ASSY. Remove the cup S M3x6 Taptite screw and two bind B M3x10 Taptite screws.
- (3) Open the Front door unit ASSY. Slide the Paper feed frame unit in the direction of arrows 3a and 3b in this order and remove it.

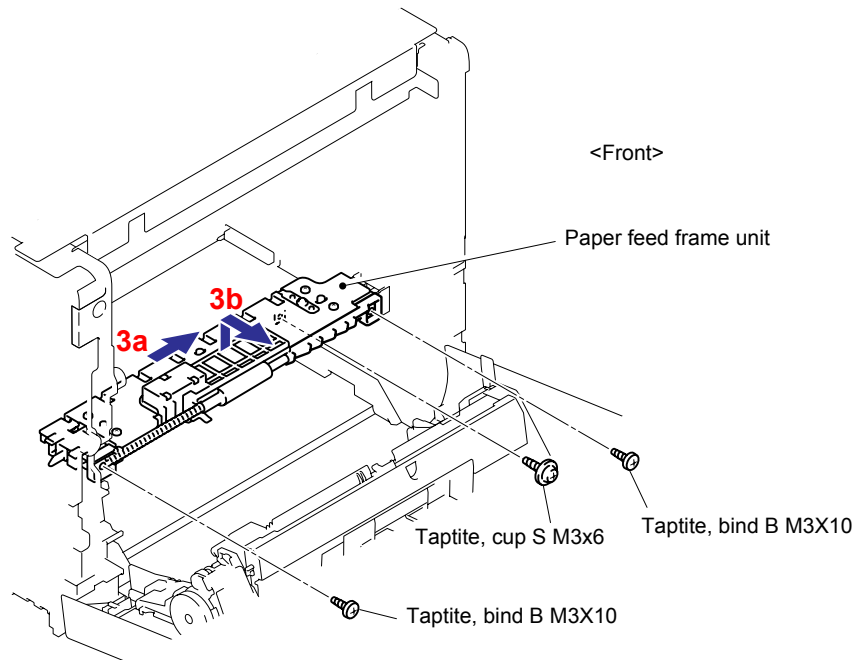

Fig. 3-113

(4) Release the two Hooks to remove the PF CR harness holder.

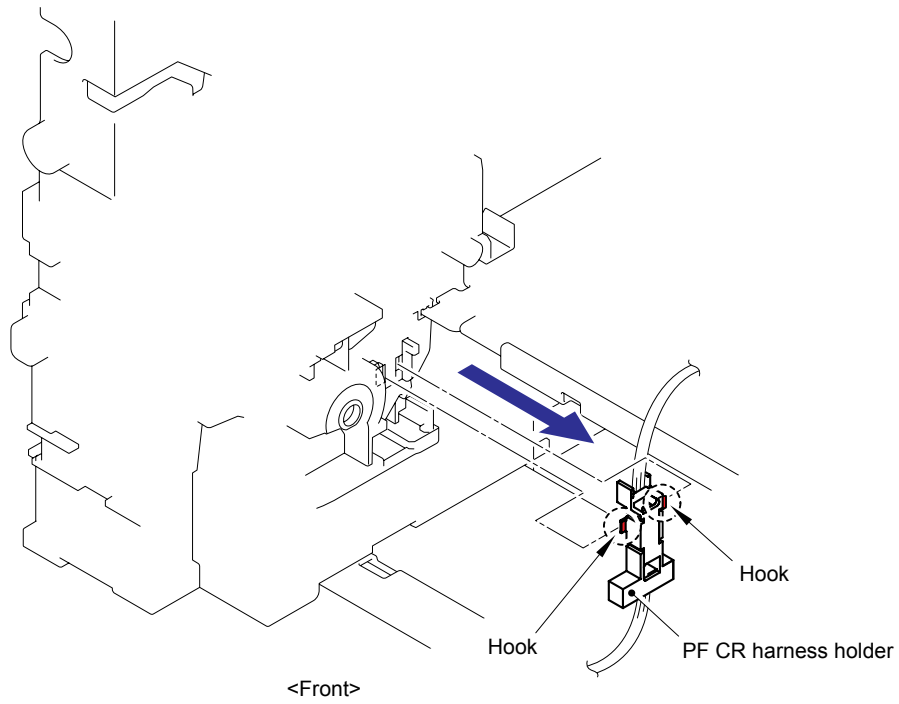

Fig. 3-114

(5) Remove the Harness from the PF CR harness holder.

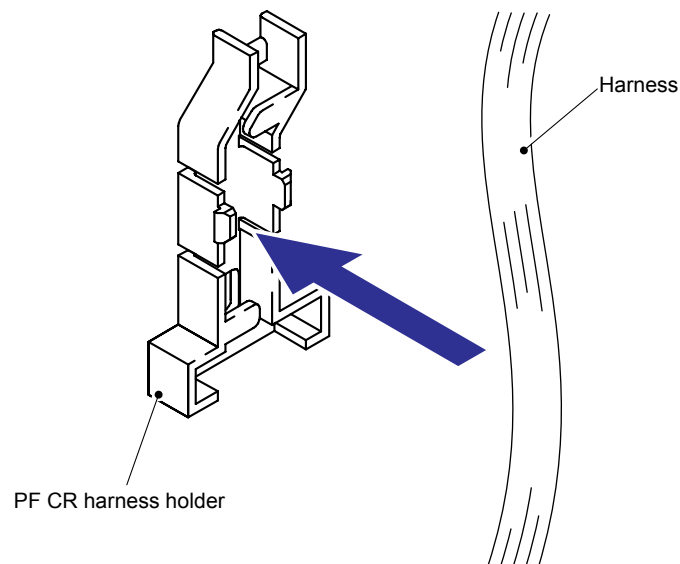

Fig. 3-115

- (6) Remove the five bind B M3x8 Taptite screws, and then remove the PF plate from the Paper feed frame.

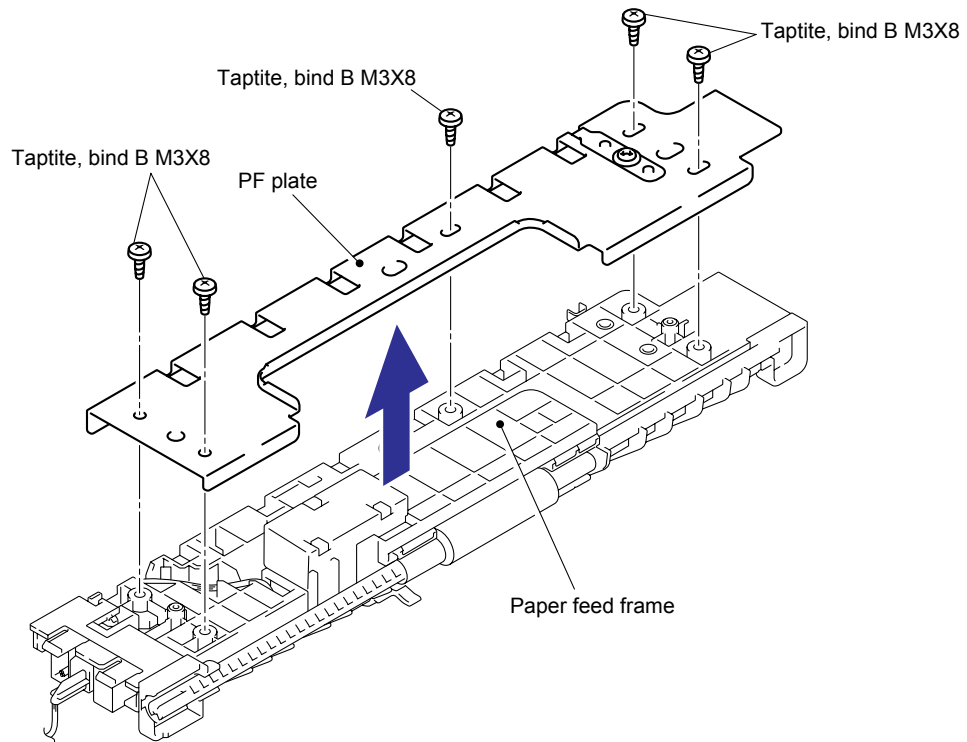

Fig. 3-116

- (7) Release the Hook of the Separation roller bush to remove it. Then, remove the Separation roller drive shaft.

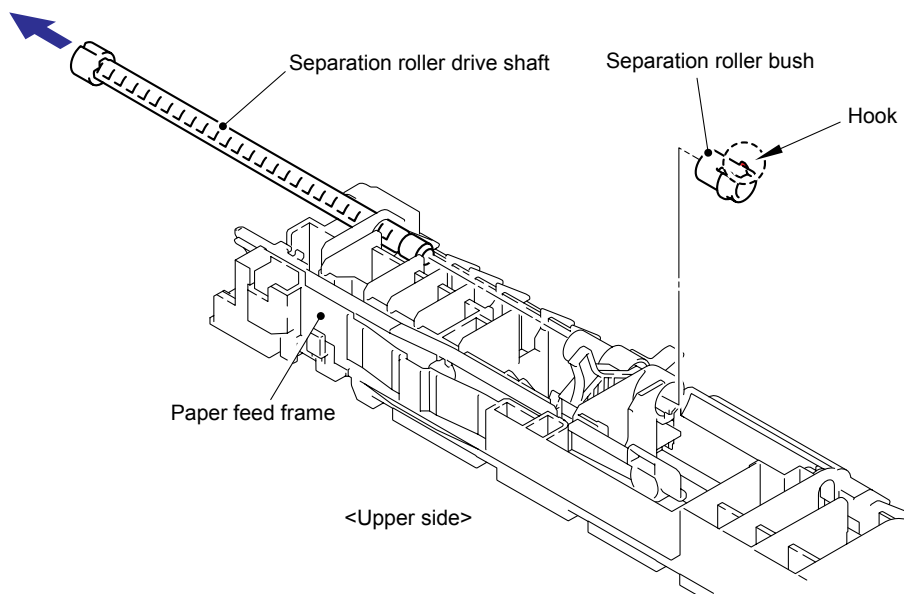

Fig. 3-117

(8) Remove the Edge actuator and PE actuator, and remove the Edge actuator spring.

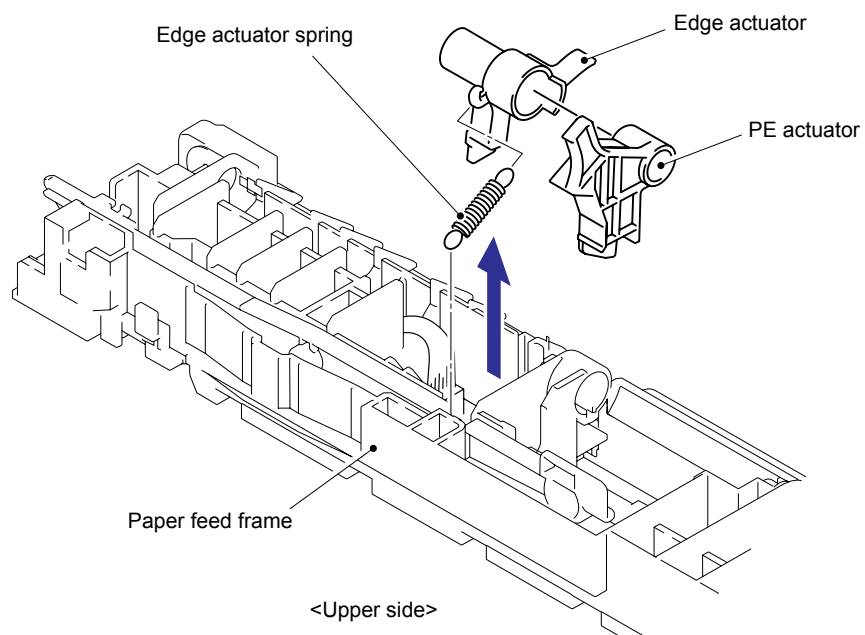

Fig. 3-118

(9) Release the three Hooks to remove the T1 PE/edge sensor PCB ASSY.

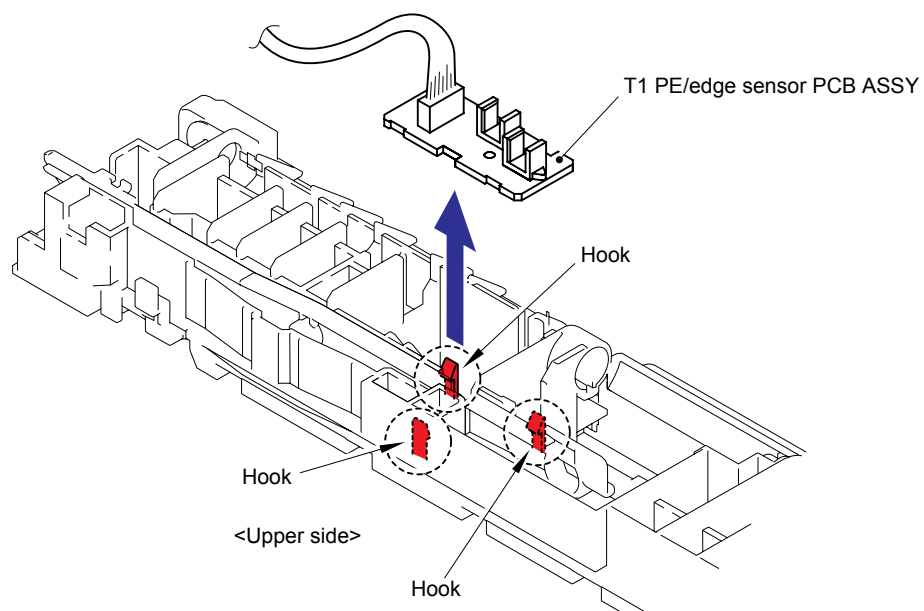

Fig. 3-119

Assembling Note:

When assembling the Paper feed frame unit, make sure to follow the procedure described below.

- (1) Put the belt cleaner release sensor harness and belt cleaner release solenoid harness through the hole on the paper feed frame.
- (2) Put the two harnesses above and T1 PE/edge sensor harness through the PF CR harness holder and put them out of the hole on the Side frame L.
- (3) Hold the PU lift up cam with a Screwdriver or similar and push to the back of the machine . The section "B" shown in Fig. 3-122 in the next page can be moved up and down by this operation, which makes it easy to assemble the lift arm.

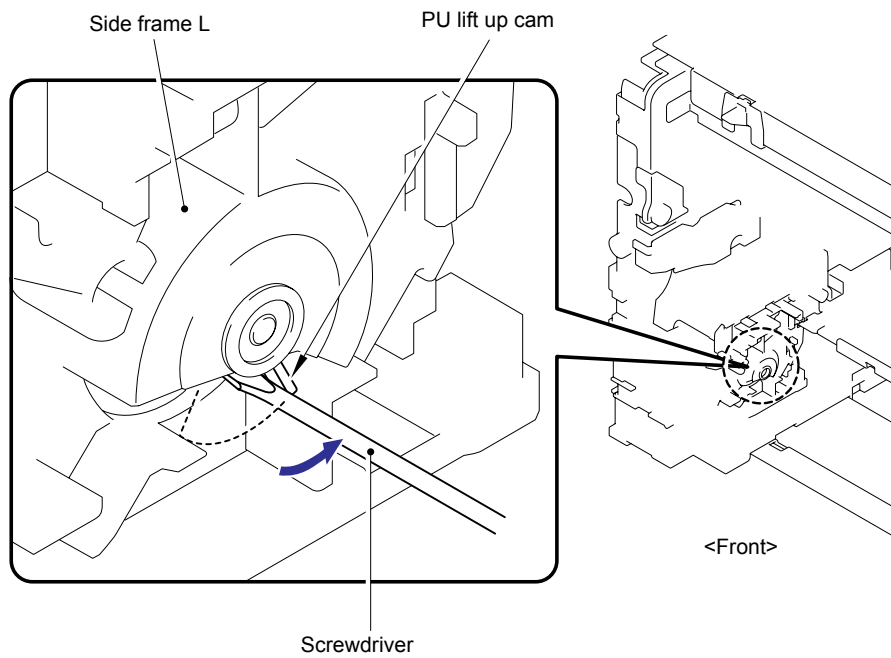

Fig. 3-120

- (4) Assemble the Lift arm, Feed roller shaft TR and Separation roller drive shaft of the Paper feed frame unit following the procedure described below.

<Assembling the Lift arm>

Implement the operations below while holding the status described in Step (3).

- 1) When pushing up the Roller holder ASSY with your hand, the end (section "A") of the Lift arm goes down. That makes easy to push the end of the Lift arm under the section "B" shown in Fig. 3-120.

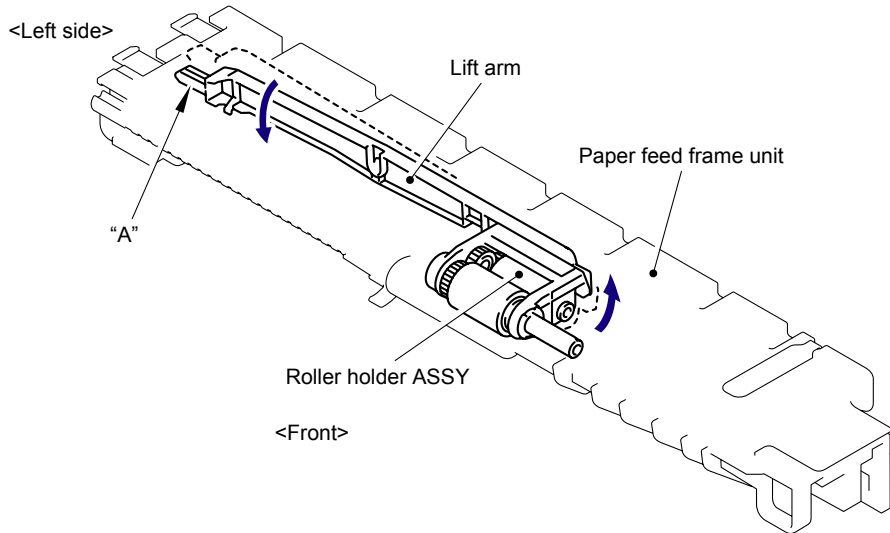

Fig. 3-121

- 2) Push up the section "B" of the Side frame L with the end (section "A") of the Lift arm and place the section "A" under the section "B". Then, make sure to put the section "A" into the space between the Hooks B and C inside the machine, and assemble the Paper feed frame unit into the machine.

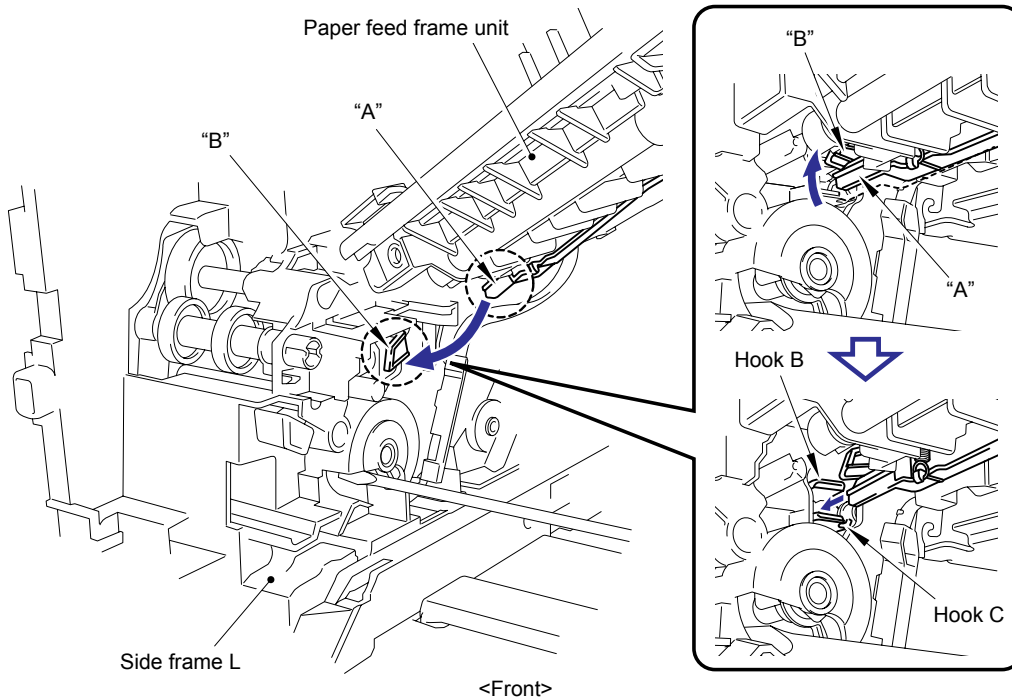

Fig. 3-122

<Assembling the Feed roller shaft TR>

While moving the Paper feed frame unit to the left hand side, turn the Gear to align the section "C" with the Feed roller shaft TR and put the shaft into the section "C".

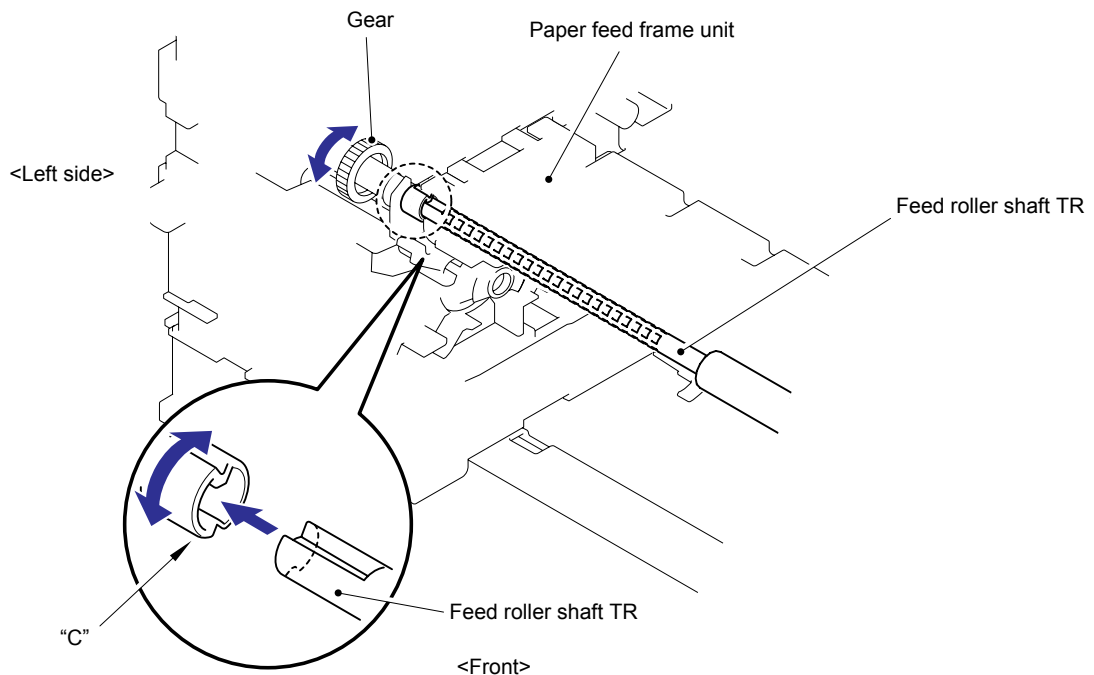

Fig. 3-123

<Assembling the Separation roller drive shaft>

While moving the Paper feed frame unit to the left hand side, turn the Separation roller of the Roller holder ASSY to align the section "D" of the Separation roller drive shaft with the section "E" of the Side frame L and put the section "E" into the section "D".

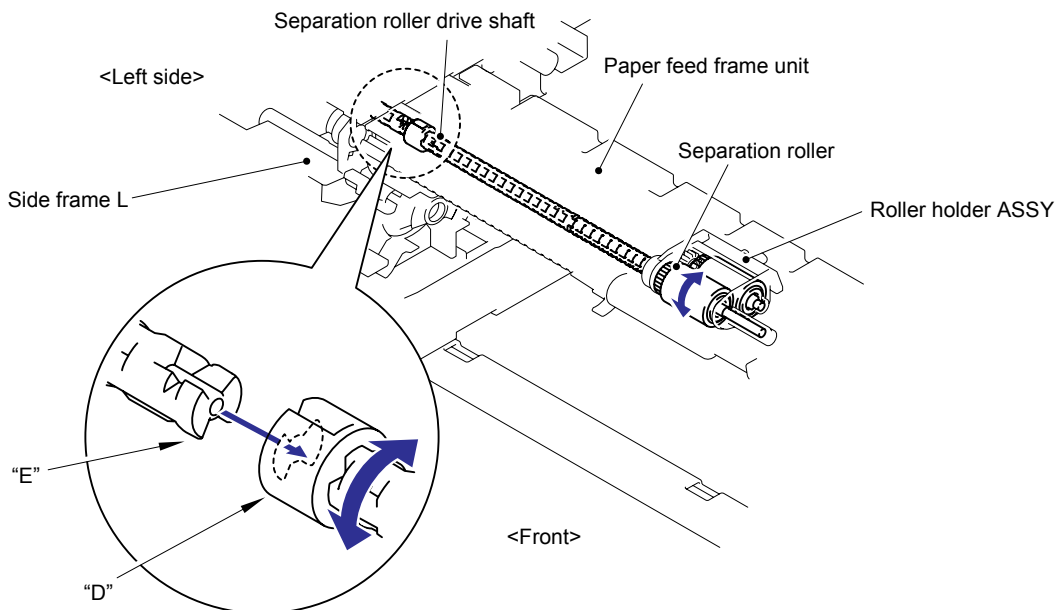

Fig. 3-124

- (5) Check the engagement of each roller and move the Paper feed frame unit to the left hand side of the main body until it stops to assemble it.

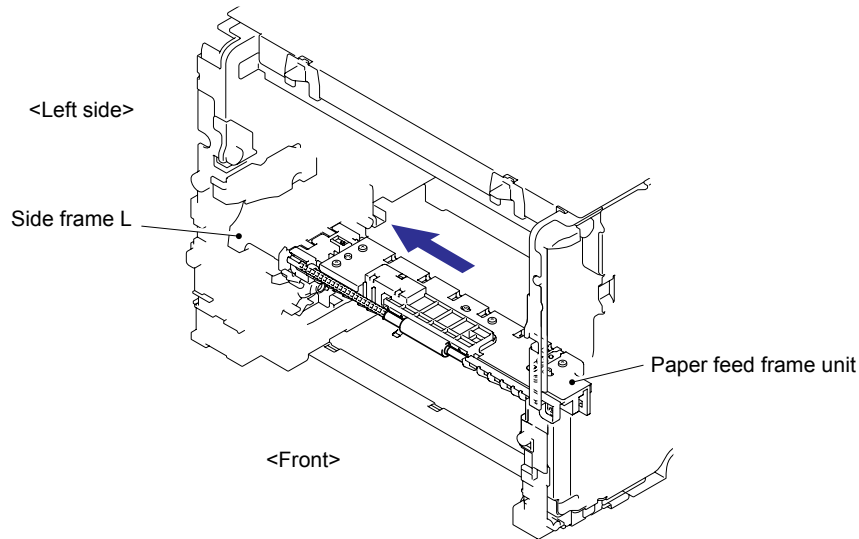

Fig. 3-125

- (6) Make sure that there is no looseness of the harness. If there is, pull the harness from the outside of the side frame L.
- (7) Check that the Feed roller TR and Roller holder ASSY are moved smoothly.

<How to check>

- Check that the Feed roller TR is turns smoothly.
- Check that the Separation roller is turns smoothly.
- Check that the Roller holder ASSY can push up smoothly.

Note:

If they are not moved smoothly, they may not be assembled correctly. Reassemble them from the beginning of the procedure.

- (8) Secure the screws in the order as shown in the figure below with the front door unit ASSY closed.

***1 Tightening Note:**

When tightening the screw, slowly turn it counterclockwise (in the direction to loosen the screw) with your hand until you feel that the screw is a little dropped in the hole. Then, slightly turn it clockwise (in the direction to tighten the screw) with your hand and tighten it according to the specified torque with a screwdriver.

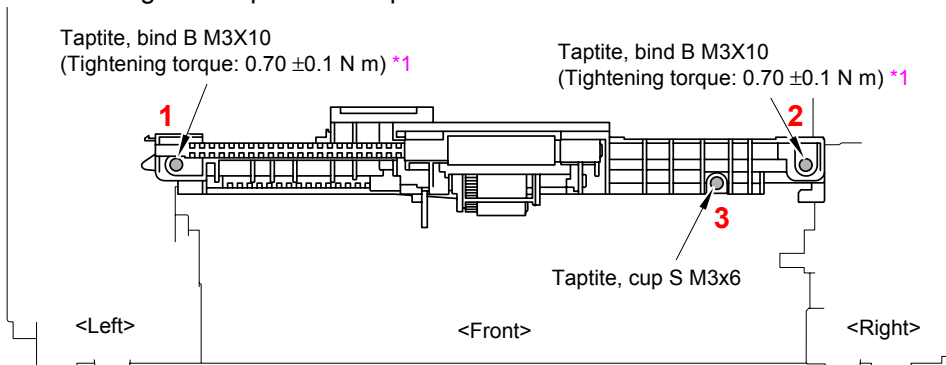

Fig. 3-126

8.25 Belt Cleaner Release Sensor PCB ASSY

(1) Release the two Hooks to remove the Belt cleaner release ASSY from the Middle plate.

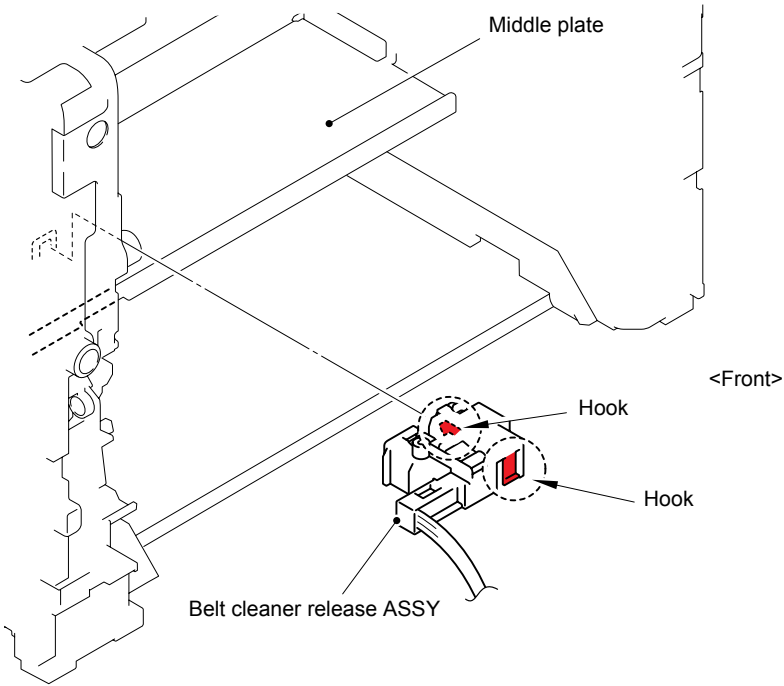

Fig. 3-127

(2) Turn the Belt cleaner release ASSY upside down. Remove the bind B M3x8 Taptite screw, and then remove the SOL PCB sheet and Belt cleaner release sensor PCB ASSY.

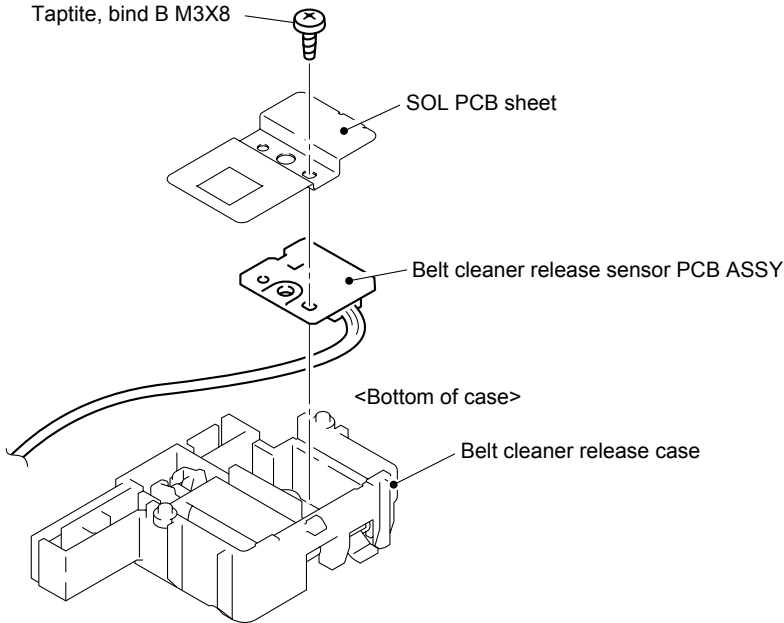

Fig. 3-128

(3) Disconnect the Connector from the Belt cleaner release sensor PCB ASSY.

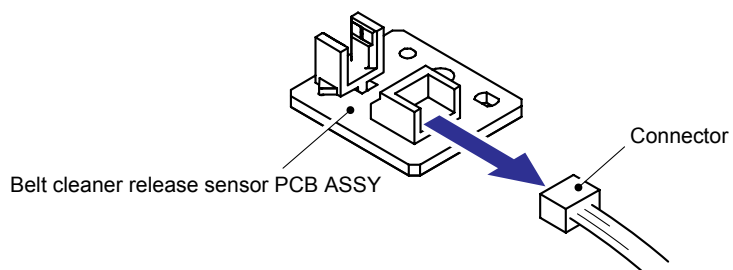

Fig. 3-129

8.26 THM/HUM Sensor Holder ASSY

(1) Disconnect the Connector (CN35) from the Engine PCB ASSY.

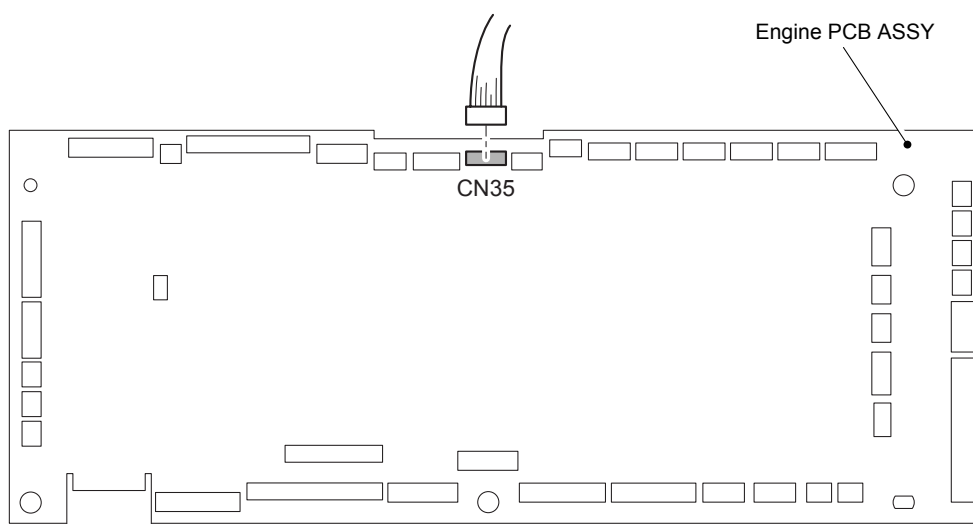

Fig. 3-130

- (2) Remove the one cup S M3x6 Taptite screw, and then remove the THM/HUM ground plate.
- (3) Remove the four cup S M3x6 Taptite screws.
- (4) Release the two Hooks to remove the THM/HUM sensor holder ASSY.

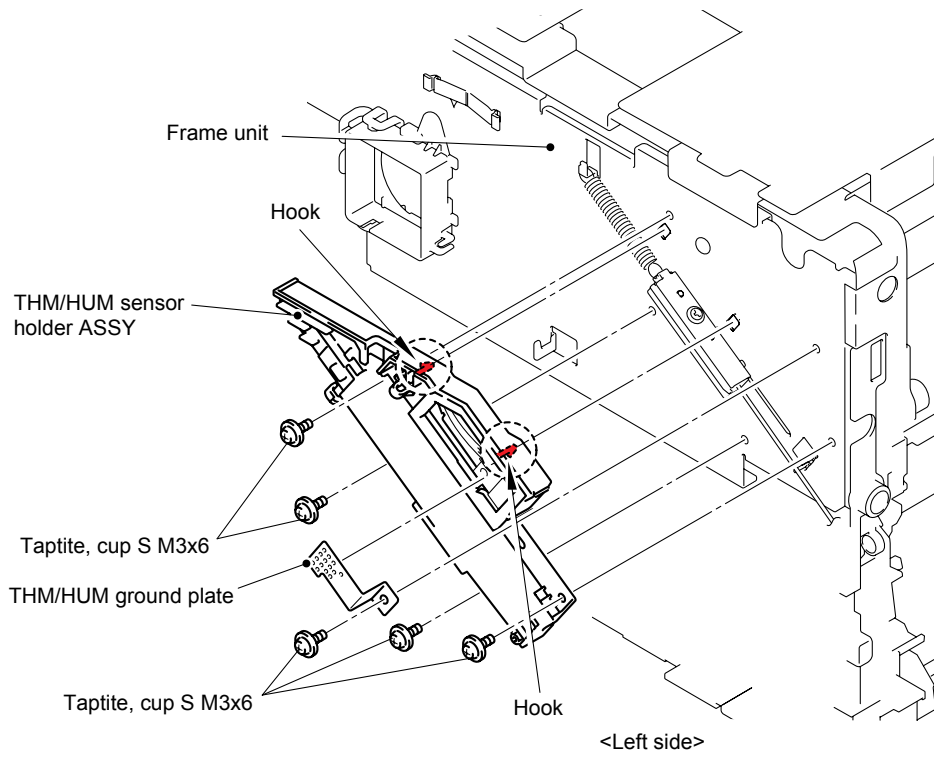

Fig. 3-131

8.27 Release Rack

(1) Remove the Release rack spring from the Hook.

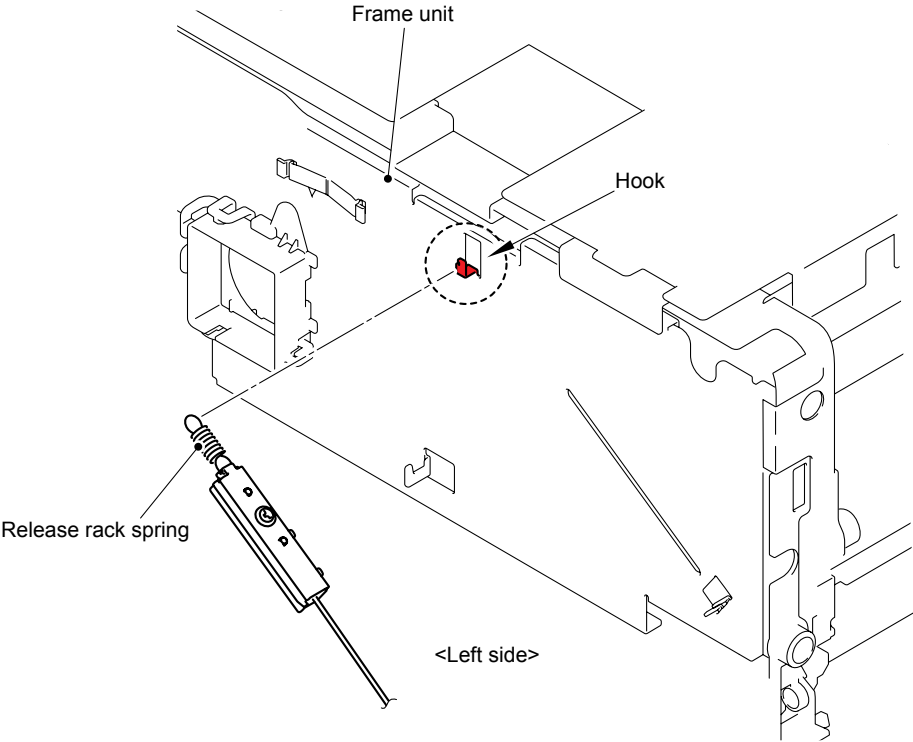

Fig. 3-132

(2) Remove the cup B M3x8 Taptite screw, and then remove the Release rack plate from the Release rack.

(3) Remove the Release rack spring from the Release rack plate.

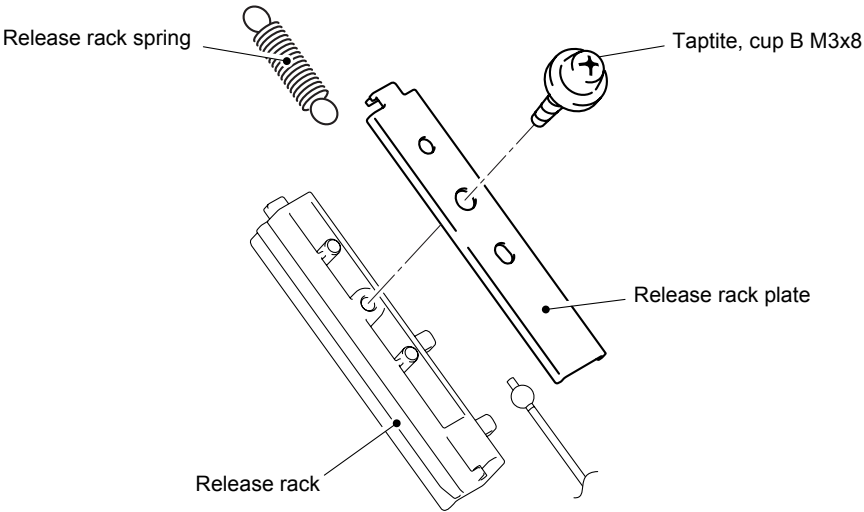

Fig. 3-133

8.28 Front Door Unit ASSY

(1) Remove the cup S M3x6 Taptite screw, and then remove the Front door unit earth.

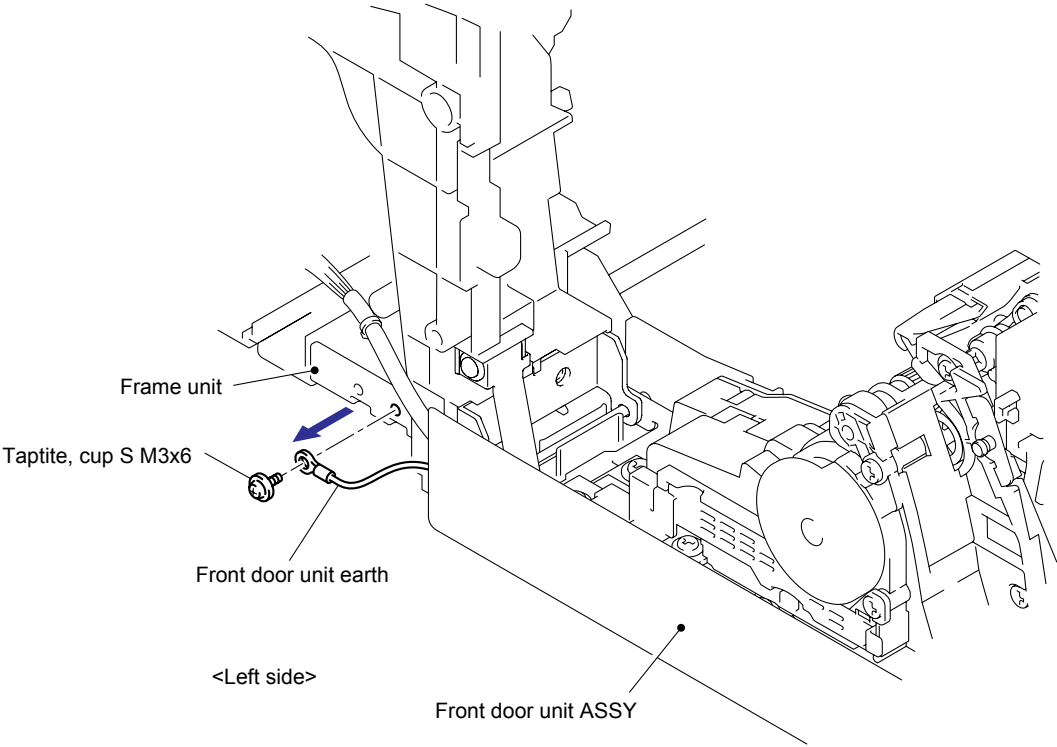

Fig. 3-134

(2) Disconnect the six connectors (CN2, CN3, CN4, CN7, CN8, CN9) from the Engine PCB ASSY.

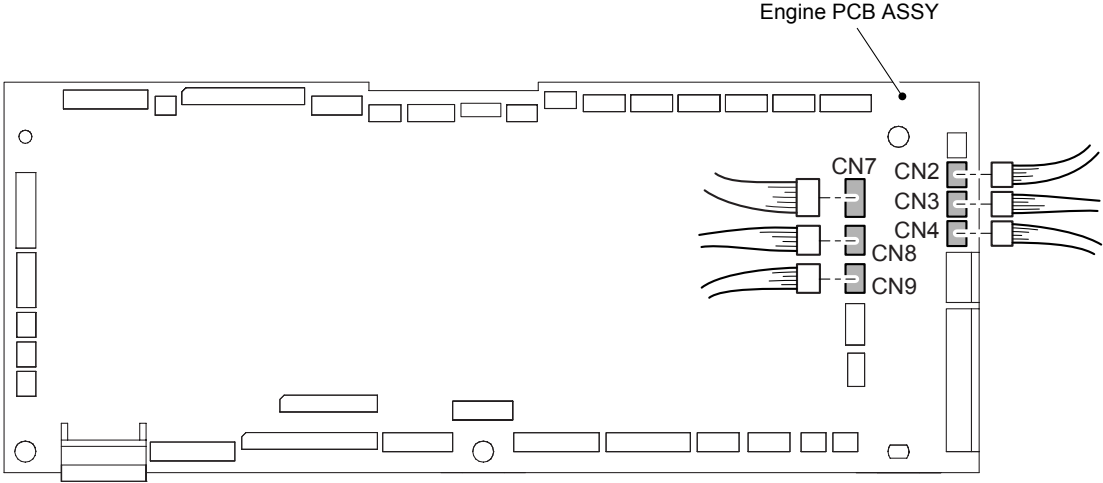

Fig. 3-135

- (3) Remove the Shoulder screw fixing the Wire support rope, and then release the Wire support rope from the Shaft.

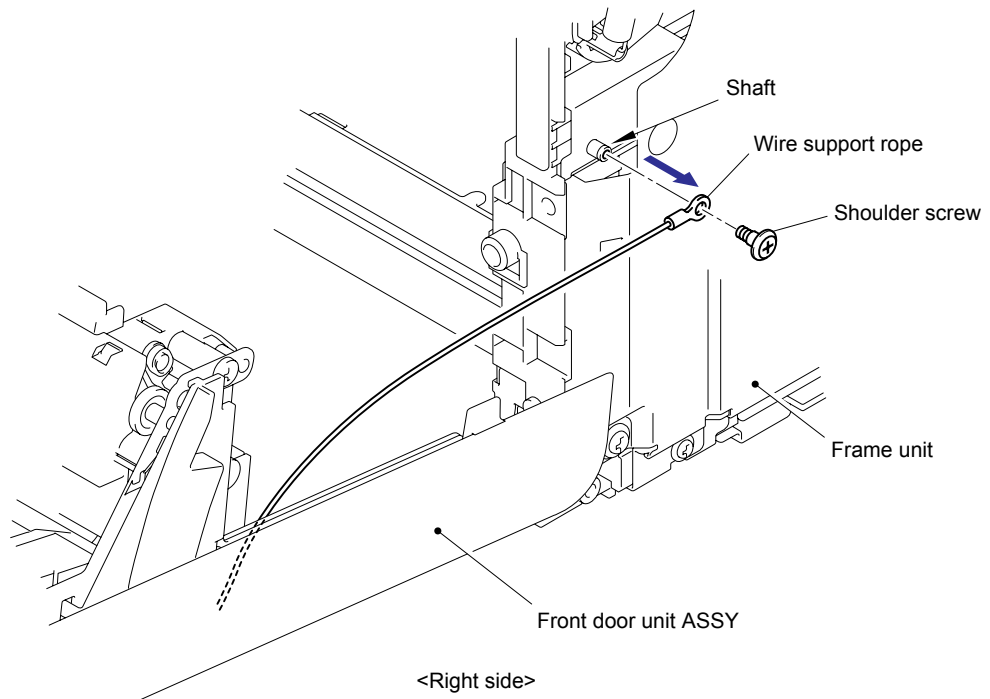

Fig. 3-136

- (4) Remove the Collar 3 from the Hinge shaft L, and then remove the Hinge shaft L from the Hinge plate L.

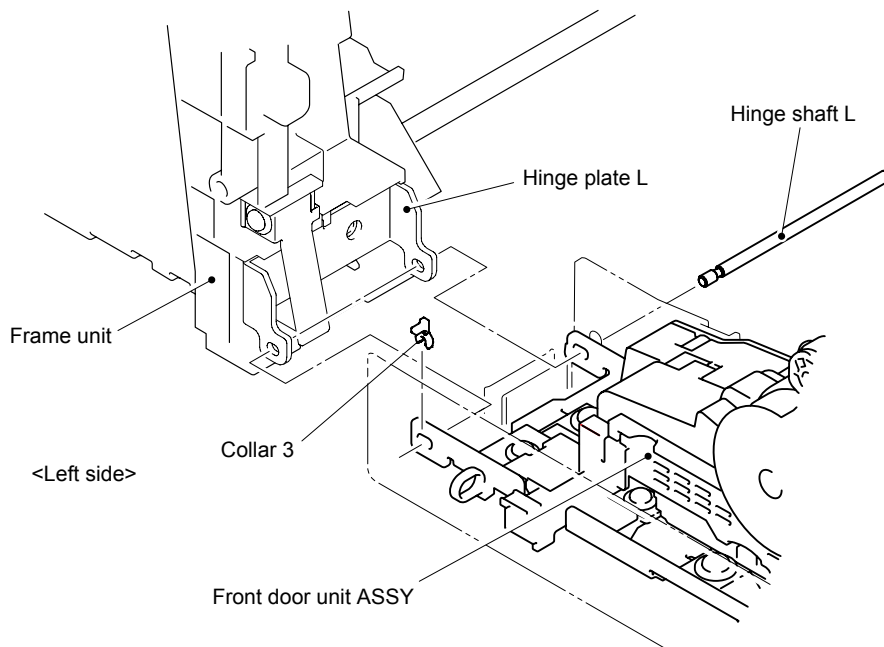

Fig. 3-137

- (5) Remove the Collar 3 from the Hinge shaft R, and then remove the Hinge shaft R from the Hinge plate R.
- (6) Remove the Front door unit ASSY from Frame unit.

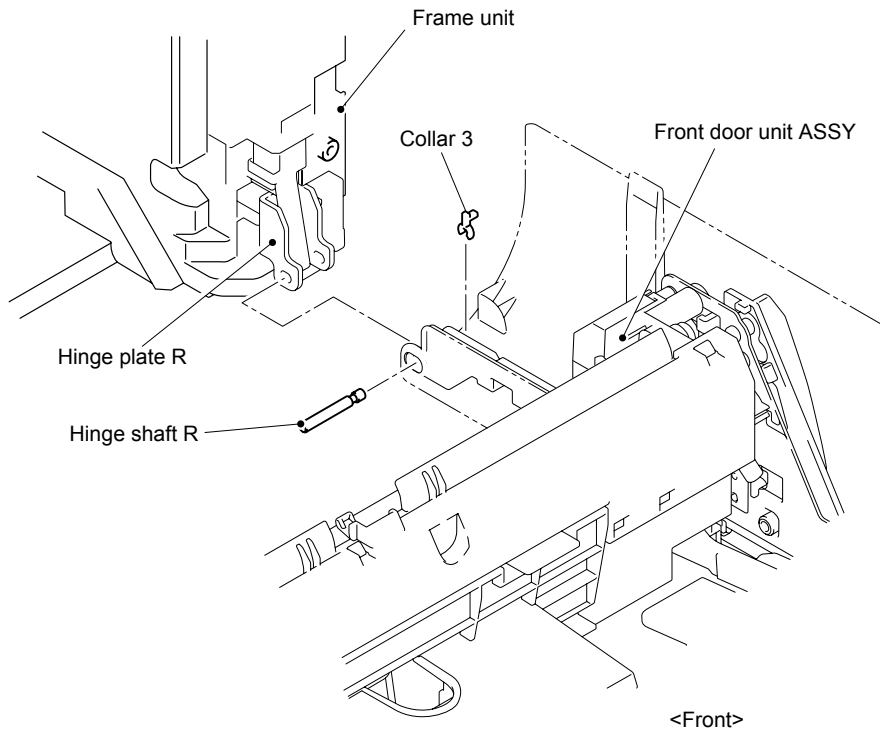

Fig. 3-138

Assembling Note:

- When assembling the Wire rope onto the Shaft on the main body, be careful of the direction of Wire rope referring to the figure below.

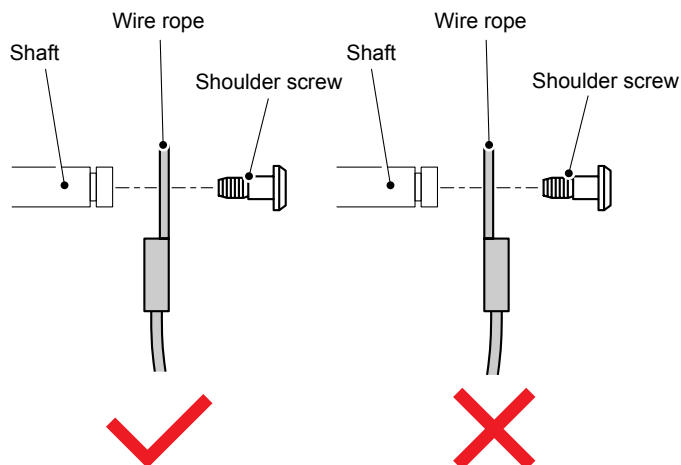

Fig. 3-139

Assembling Note:

- When assembling the Front door unit ASSY onto the Hinge on the main body, make sure to align the Front door unit ASSY with the Hinge as shown in the figure below.

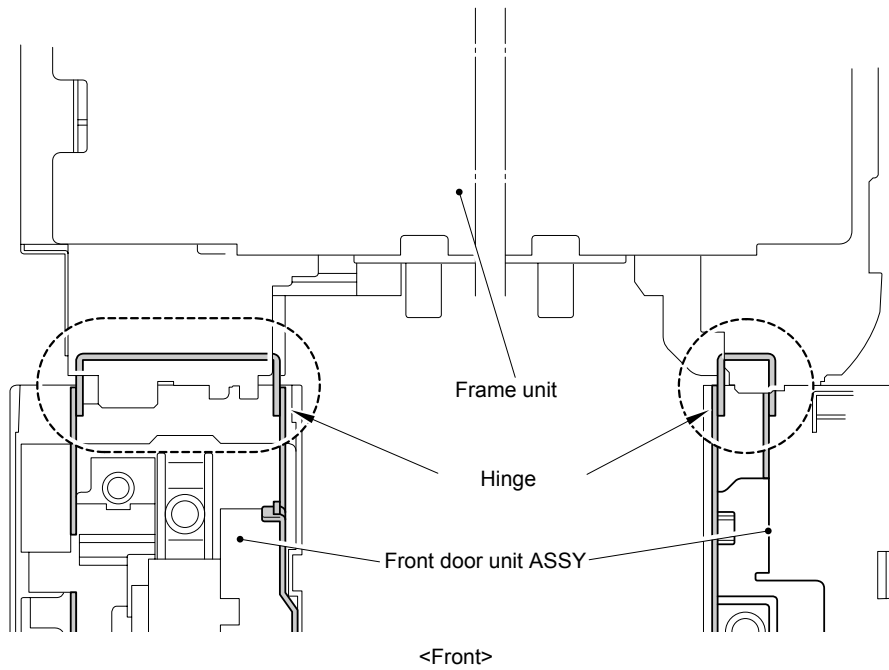

Fig. 3-140

8.29 Harness Cover MP

- (1) Remove the cup S M3x6 Taptite screw, and then remove the Harness cover MP from the Front door unit ASSY.

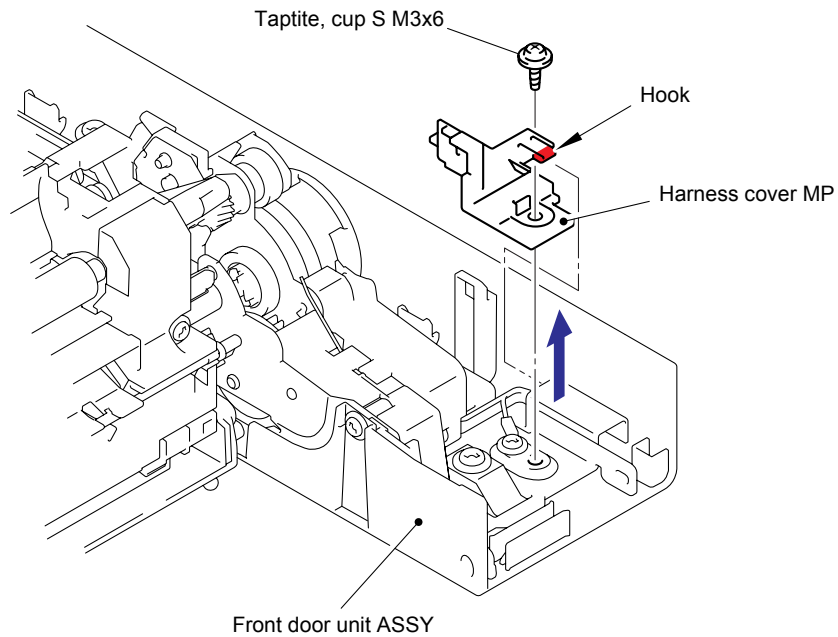

Fig. 3-141

8.30 Front Door Sub

- (1) Remove the five cup B M4x10 Taptite screws and one cup B M3x8 Taptite screw, and then remove the Front door sub.

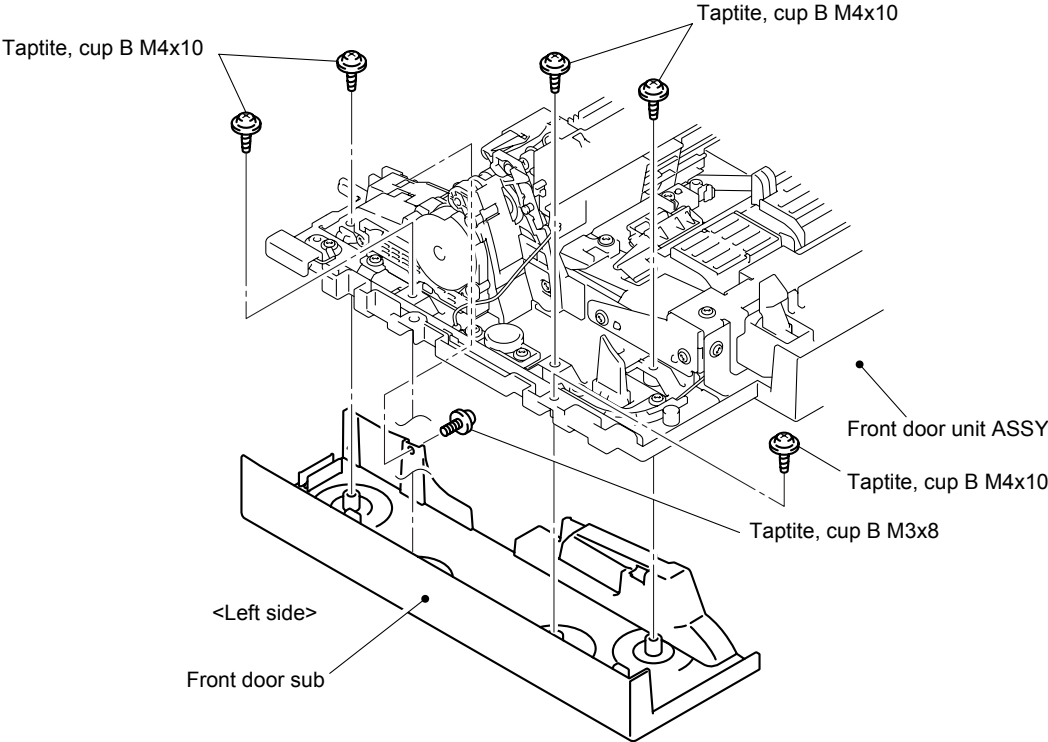

Fig. 3-142

8.31 EL Electrode Spring L/R

- (1) Remove the two bind B M3x8 Taptite screws, and then remove the EL electrode spring cover ASSY.

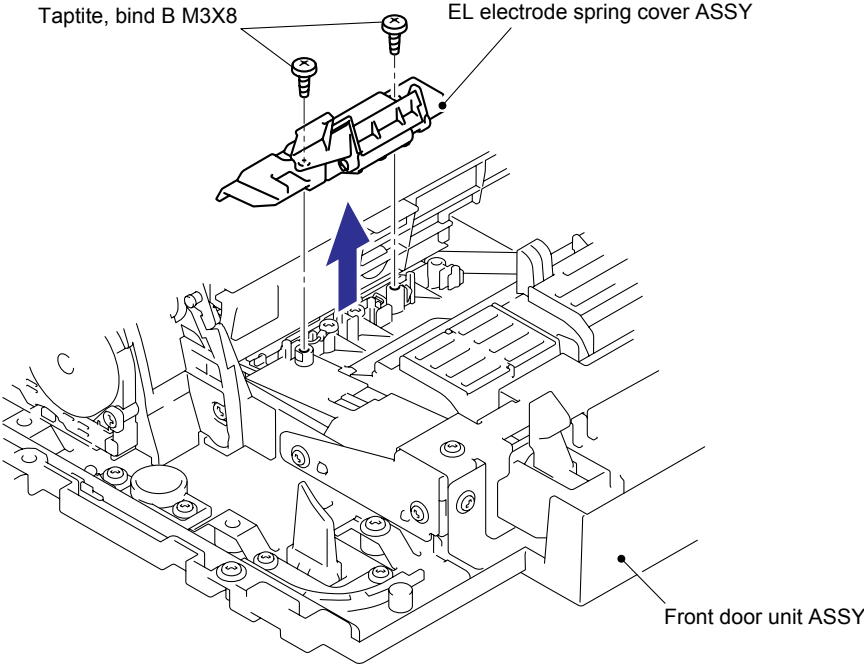

Fig. 3-143

- (2) Remove the two bind B M3x8 Taptite screws, and then remove the EL spring harness ASSY (white, red) and EL electrode spring L/R.

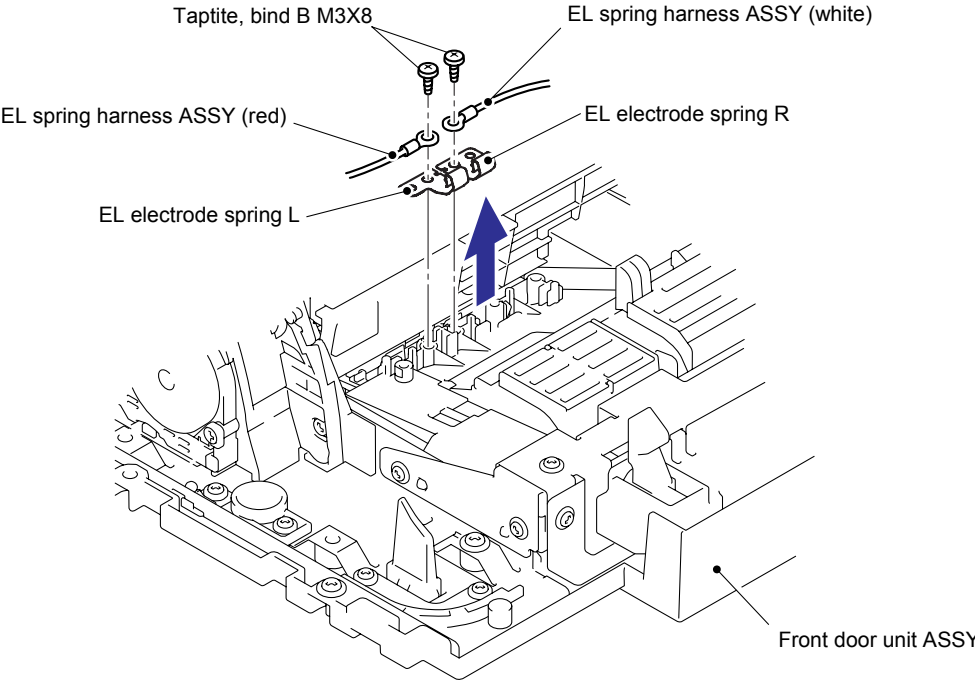

Fig. 3-144

8.32 Hook Cover/ Front Cover Release Button/ Button Spring/ Front Door Main

(1) Remove the two cup B M4x10 Taptite screws.

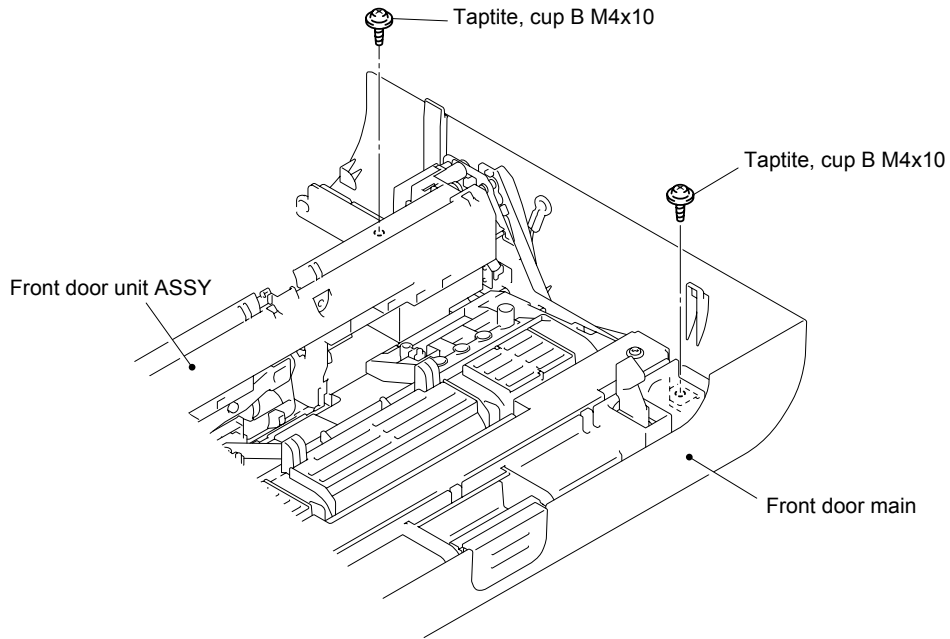

Fig. 3-145

(2) Remove the two cup B M4x10 Taptite screws.

(3) Release the three Hooks to remove the Hook cover from the Front door unit ASSY.

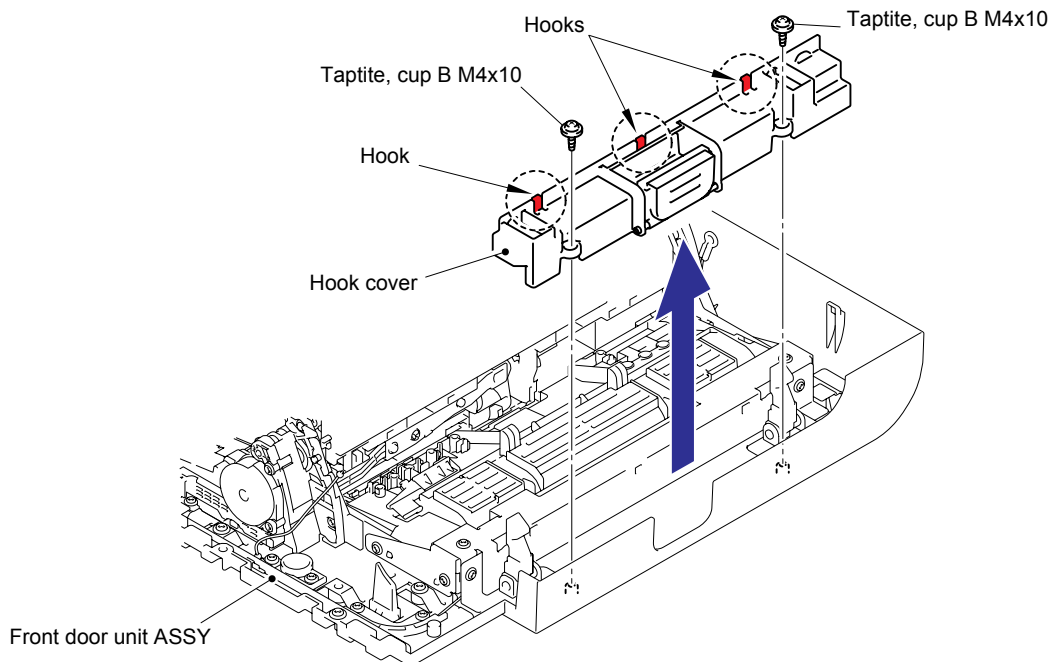

Fig. 3-146

(4) Remove the Front cover release button and Button spring from the Hook cover.

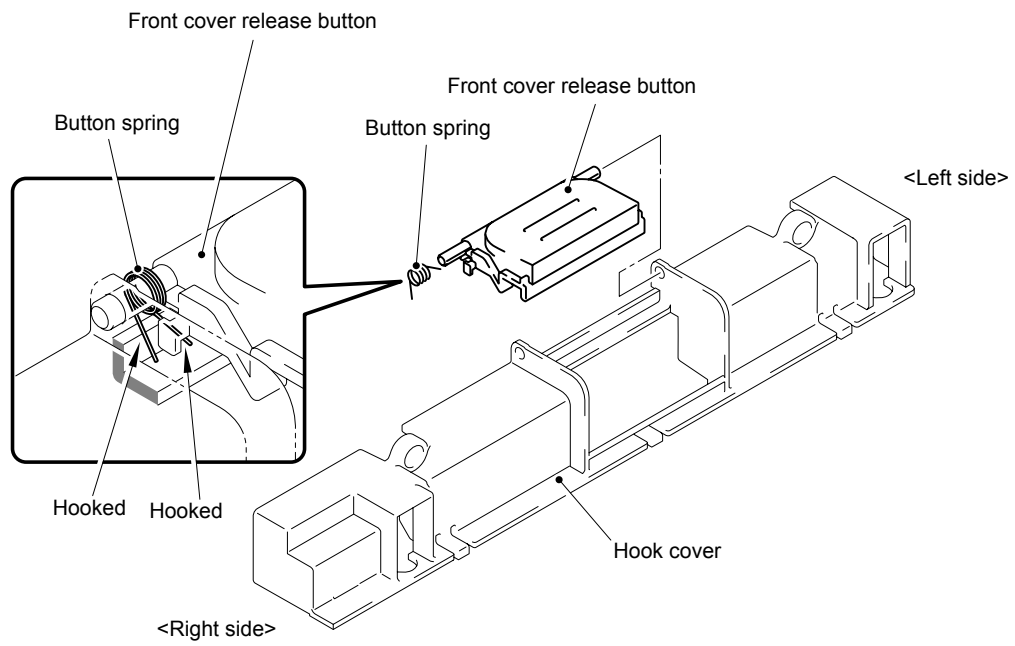

Fig. 3-147

(5) Release the two Hooks to remove the Front door Main from the Front door unit ASSY.

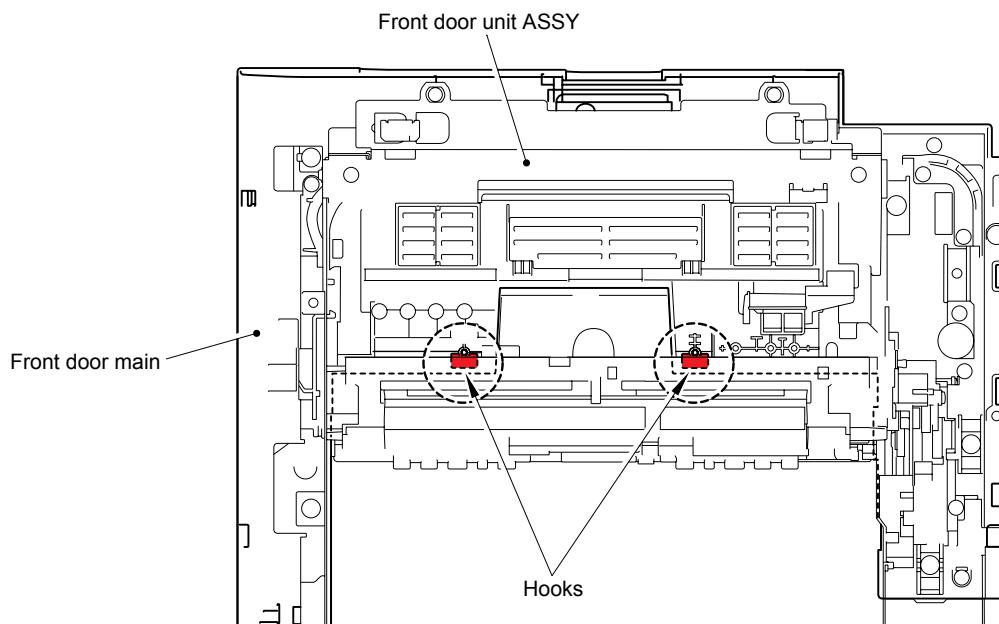

Fig. 3-148

8.33 Hook Shaft/ Hook/ Hook Spring

- (1) Remove the Hook shaft.

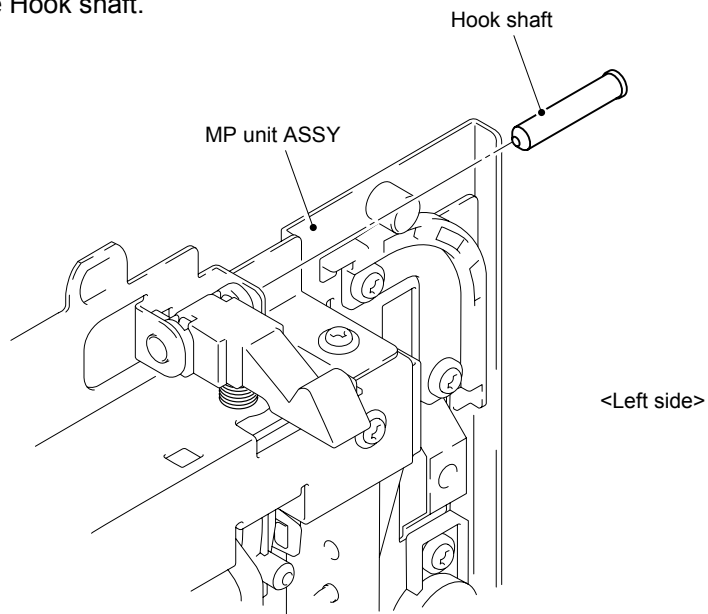

Fig. 3-149

- (2) Remove the Hook and Hook spring L from the MP unit ASSY.
- (3) Remove the Hook and Hook spring R from the MP unit ASSY in the same way.

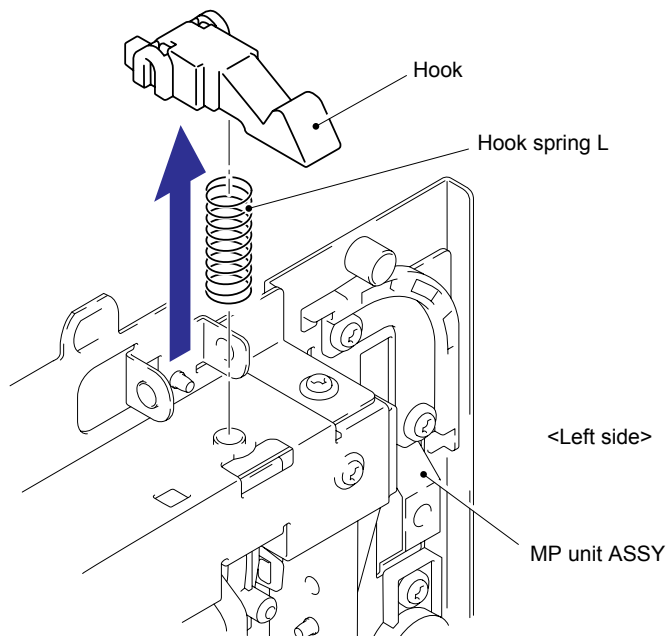

Fig. 3-150

Assembling Note:

When assembling the Hook spring, be sure to assemble each of the Hook springs Left and Right onto the correct sides (Left is longer silver one and Right is shorter black one).

8.34 Engine PCB ASSY

(1) Disconnect all the connectors from the Engine PCB ASSY.

Note:

- After disconnecting the flat cable(s), check that each cable is not damaged at its end or short-circuited.
- When connecting the flat cable(s), do not insert it at an angle. After insertion, check that the cable is not at an angle.

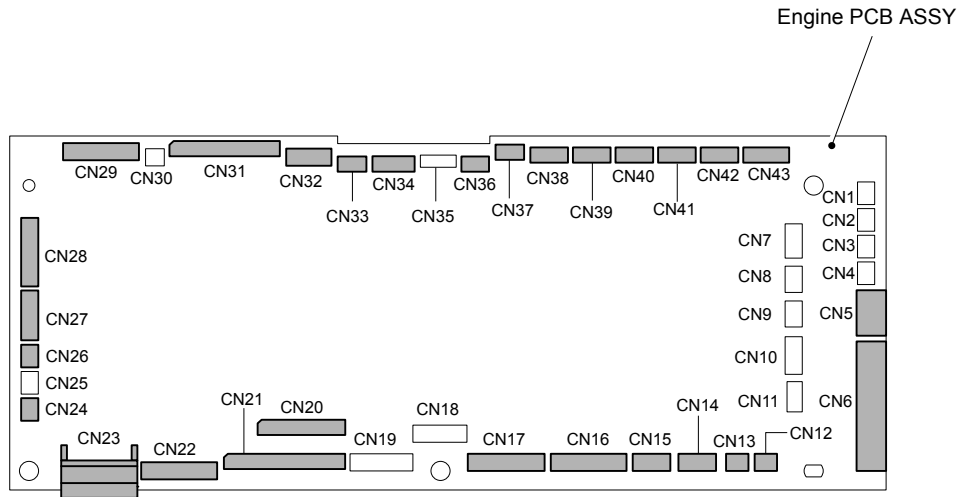

Fig. 3-151

(2) Remove the five cup S M3x6 Taptite screws, and then remove the Engine PCB ASSY from the Frame unit.

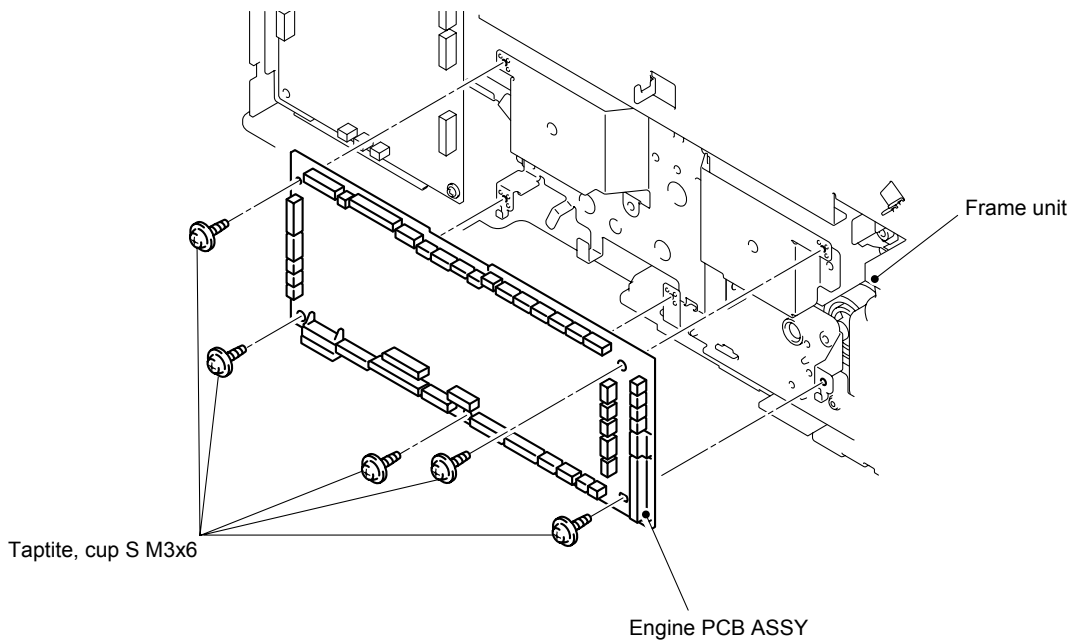

Fig. 3-152

8.35 Main PCB ASSY/ Ground Plate/ Ground Spring Plate

- (1) Remove the cup S M3x6 Taptite screw and bind B M4x12 Taptite screw, and then remove the Ground plate.
- (2) Remove the two cup S M3x6 Taptite screws, and then remove the Ground spring plate.

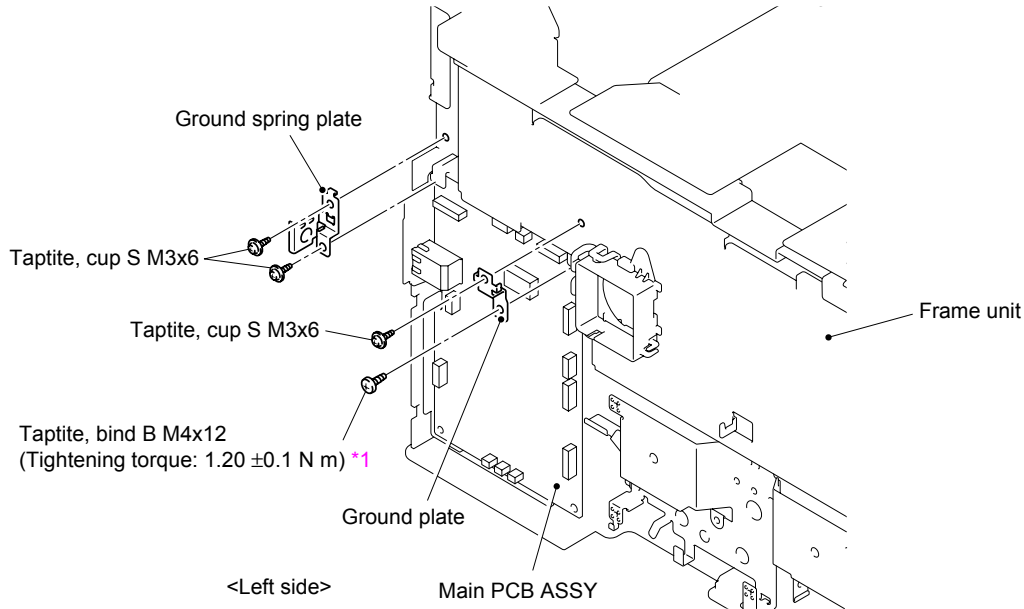

Fig. 3-153

***1 Tightening Note:**

When tightening the screw, slowly turn it counterclockwise (in the direction to loosen the screw) with your hand until you feel that the screw is a little dropped in the hole. Then, slightly turn it clockwise (in the direction to tighten the screw) with your hand and tighten it according to the specified torque with a screwdriver.

- (3) Disconnect all the connectors from the Main PCB ASSY.

Note:

- After disconnecting the flat cable(s), check that each cable is not damaged at its end or short-circuited.
- When connecting the flat cable(s), do not insert it at an angle. After insertion, check that the cable is not at an angle.

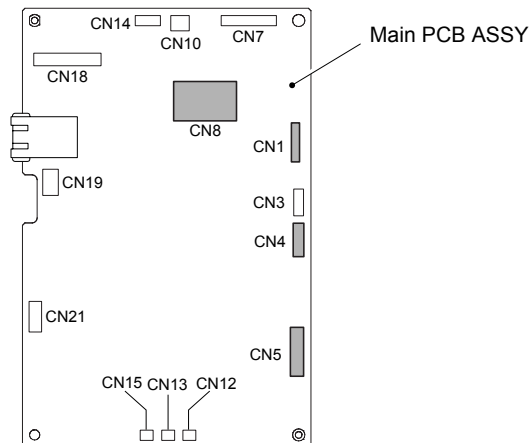

Fig. 3-154

- (4) Remove the cup S M3x6 Taptite screw, and then remove the Main PCB ASSY as shown by arrows 4a and 4b.

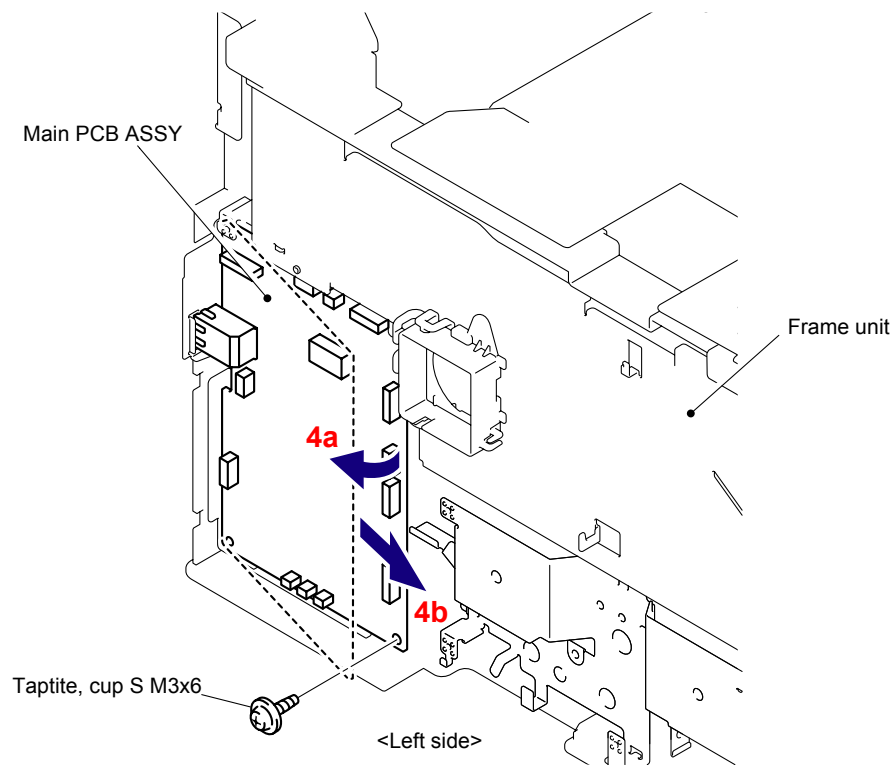

Fig. 3-155

8.36 Waste Toner Near/Full Sensor ASSY

- (1) Move the Positioning pin 1a as shown, and slide the Hooks to the direction of the arrow 1b, and then remove the Waste toner sensor holder from the Middle plate.

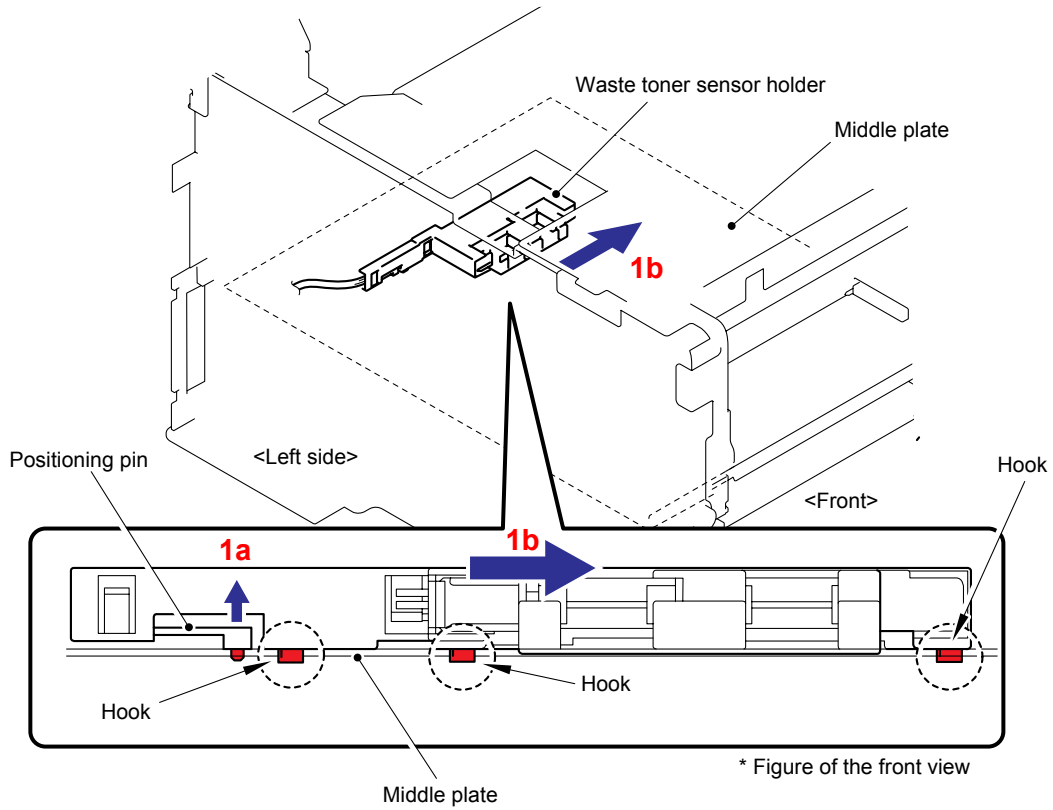

Fig. 3-156

- (2) Release the Hook to remove the Waste toner sensor cover from the Waste toner sensor holder.

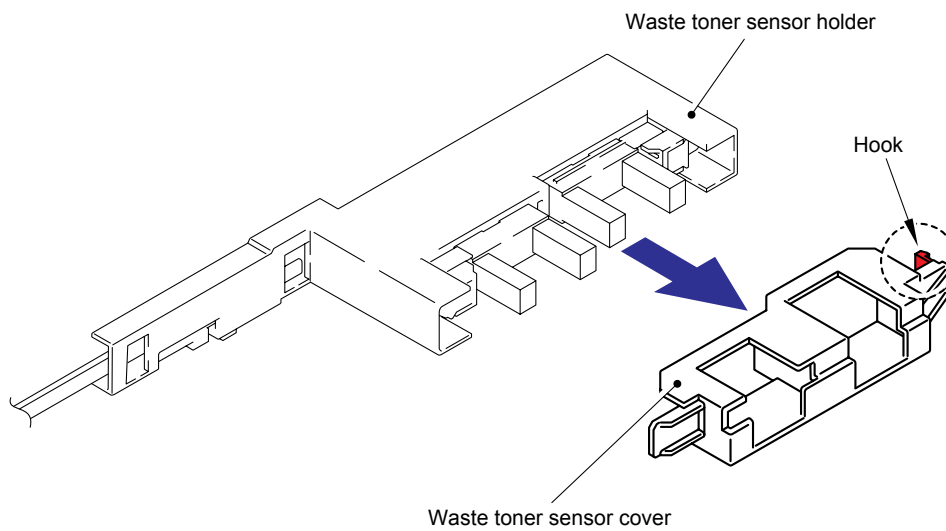

Fig. 3-157

- (3) Release the three Hooks of each Waste toner sensor to remove the two Waste toner sensors from the Waste toner sensor holder.

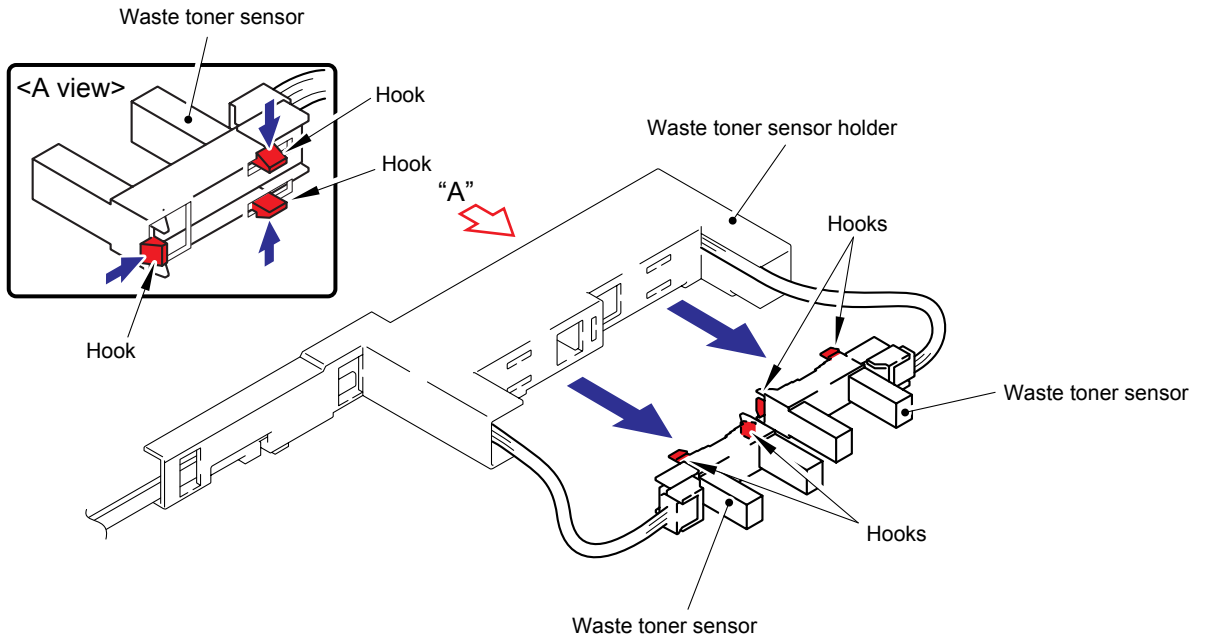

Fig. 3-158

- (4) Disconnect the Connectors (yellow and blue) from each of the Waste toner sensors.

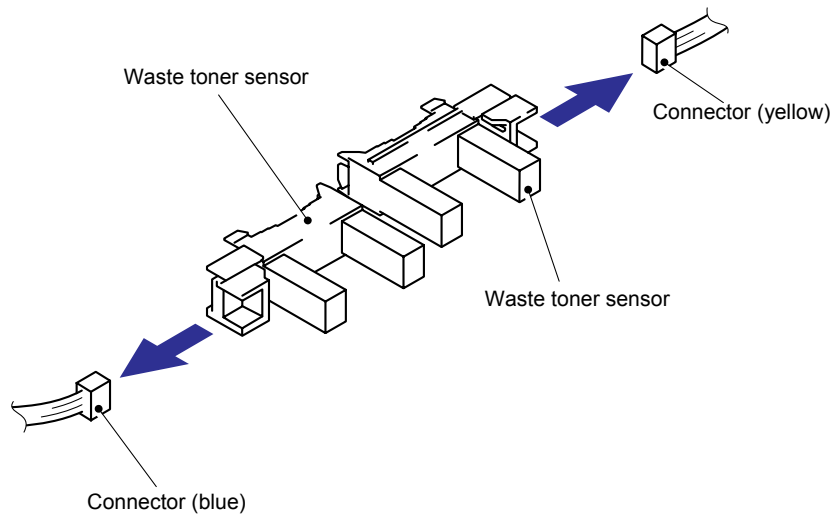

Fig. 3-159

8.37 Laser Unit/ Hook Slope

- (1) Remove the four cup S M3x8 Taptite screws, and then remove the two Hook slopes.

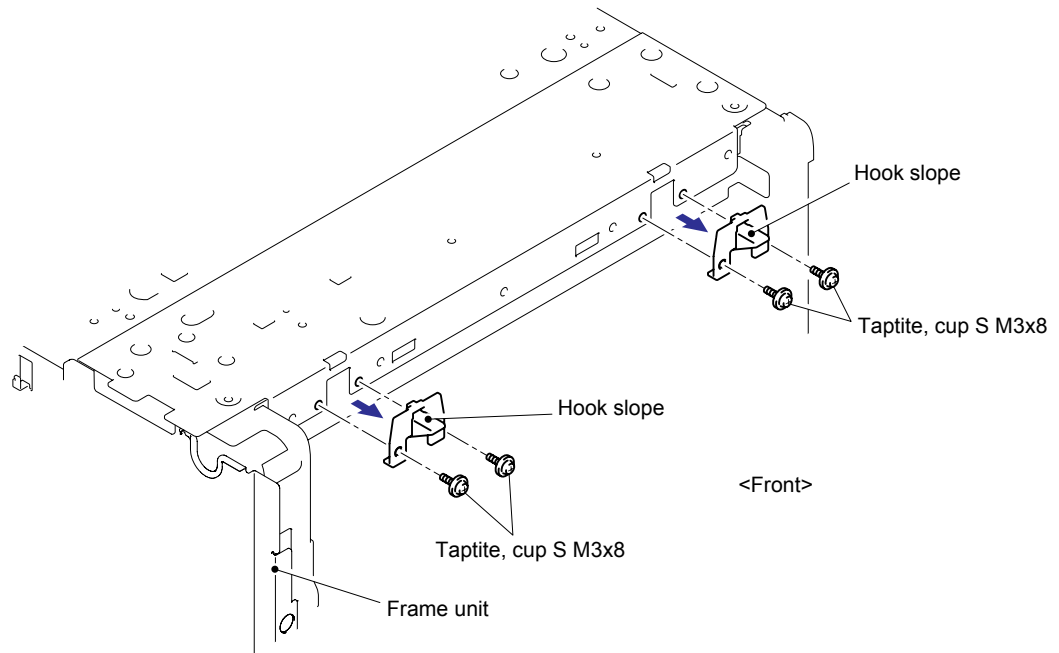

Fig. 3-160

- (2) Remove the nine cup S M3x6 Taptite screws (8 pieces from the top and 1 piece from the Front), and then remove the Scanner cover.

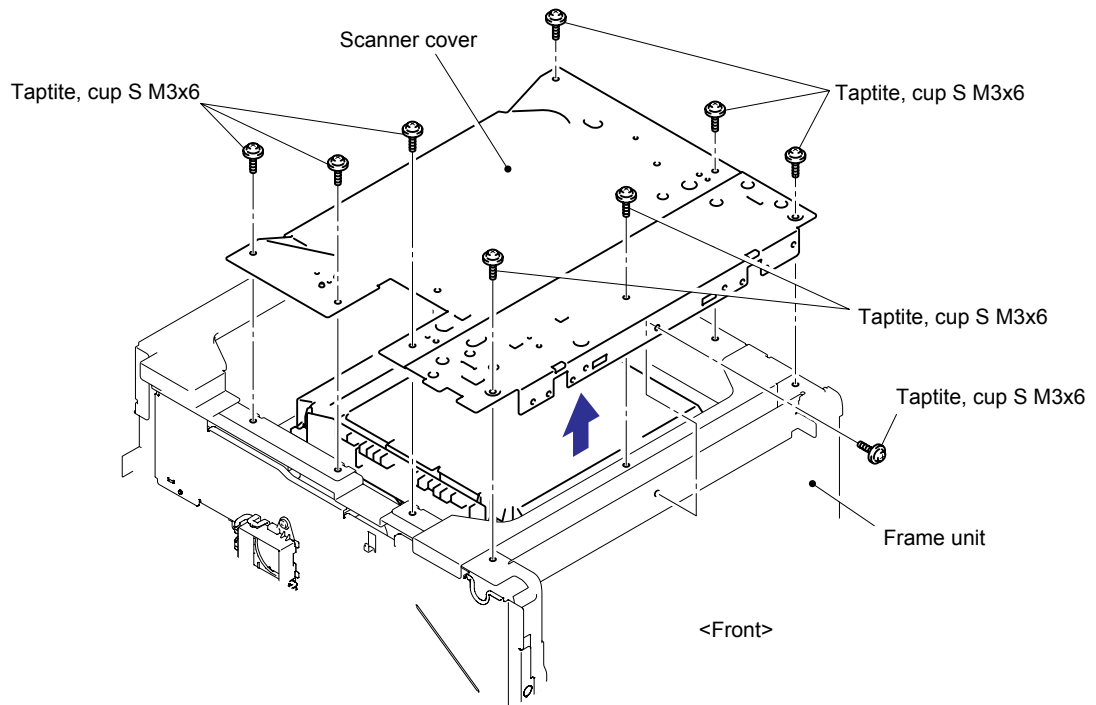

Fig. 3-161

Assembling Note:

When assembling the Scanner cover, secure the screws in the order of the numbers which are indicated on the Scanner cover.

(3) Disconnect the two flat cables (CN1, CN4) and connector (CN8) from the Laser unit.

Note:

- After disconnecting the flat cable(s), check that each cable is not damaged at its end or short-circuited.
- When connecting the flat cable(s), do not insert it at an angle. After insertion, check that the cable is not at an angle.

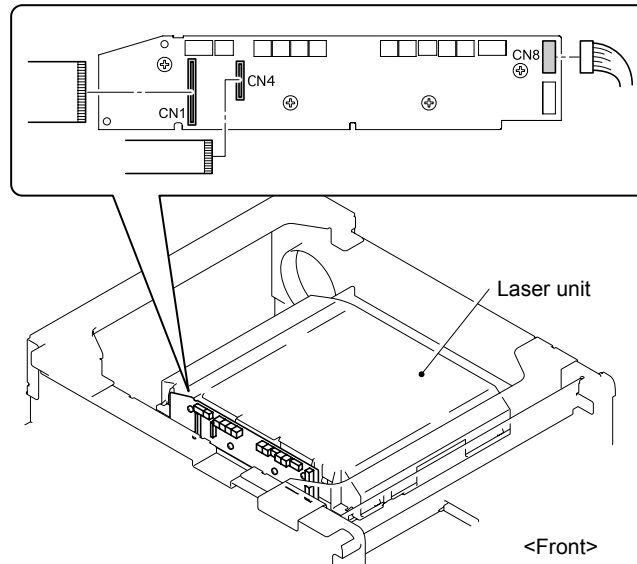

Fig. 3-162

(4) Remove the seven cup S M3x6 SR Taptite screws, and then remove the four Scanner holders and Laser unit.

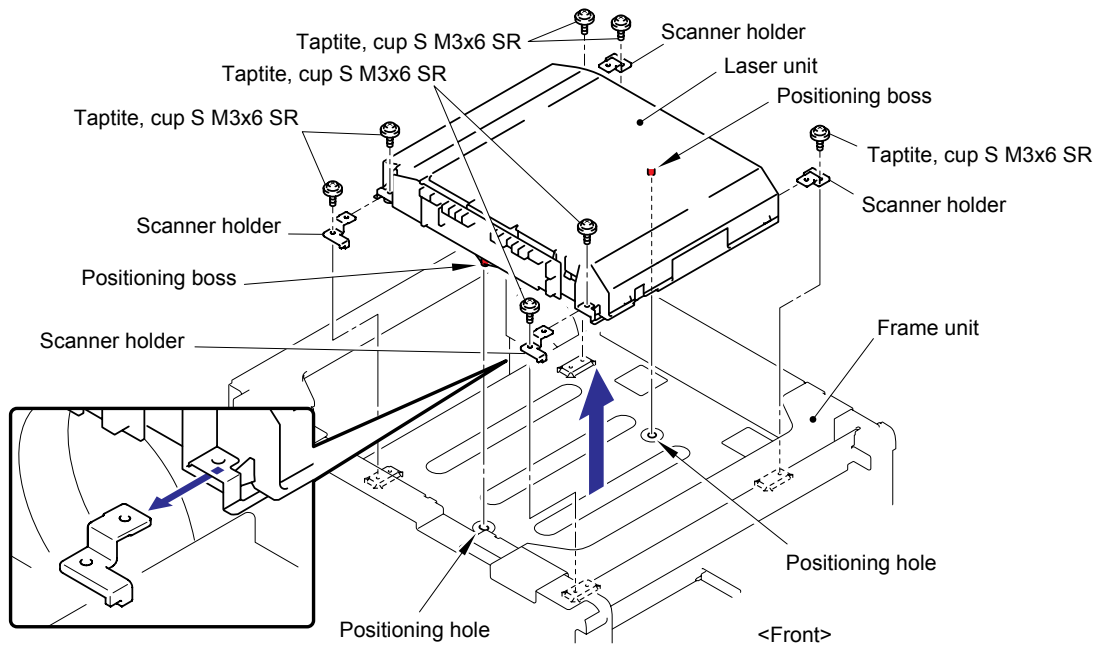

Fig. 3-163

Assembling Note:

When assembling the Laser unit with the Scanner holders, ensure to put the positioning boss of the Laser unit into the positioning hole referring to the figure above.

8.38 Develop Drive Motor ASSY

- (1) Remove the Rack gear 27 from the Frame unit.

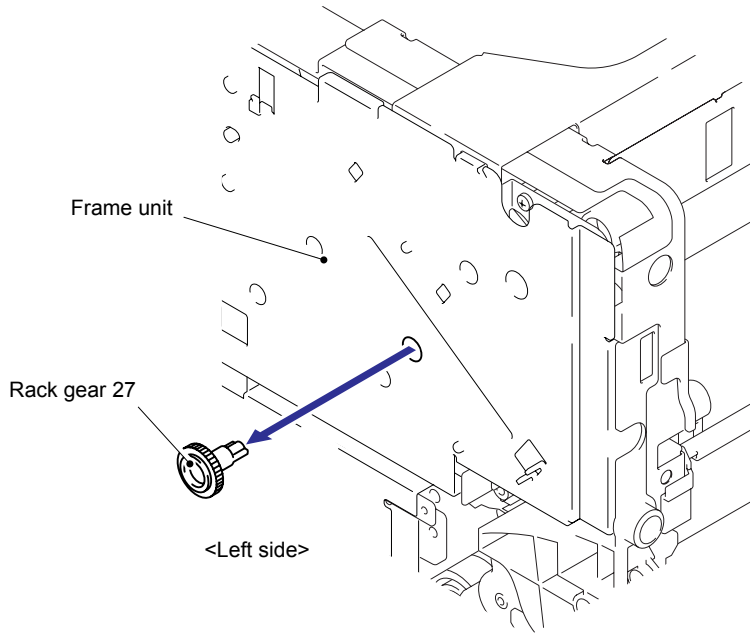

Fig. 3-164

- (2) Remove the Alum sheet frame from the Develop gear plate ASSY.
- (3) Remove the seven cup S M3x6 Taptite screws, and then remove the Develop gear plate ASSY from the Frame unit. Disconnect the Connector from the Develop drive motor ASSY.

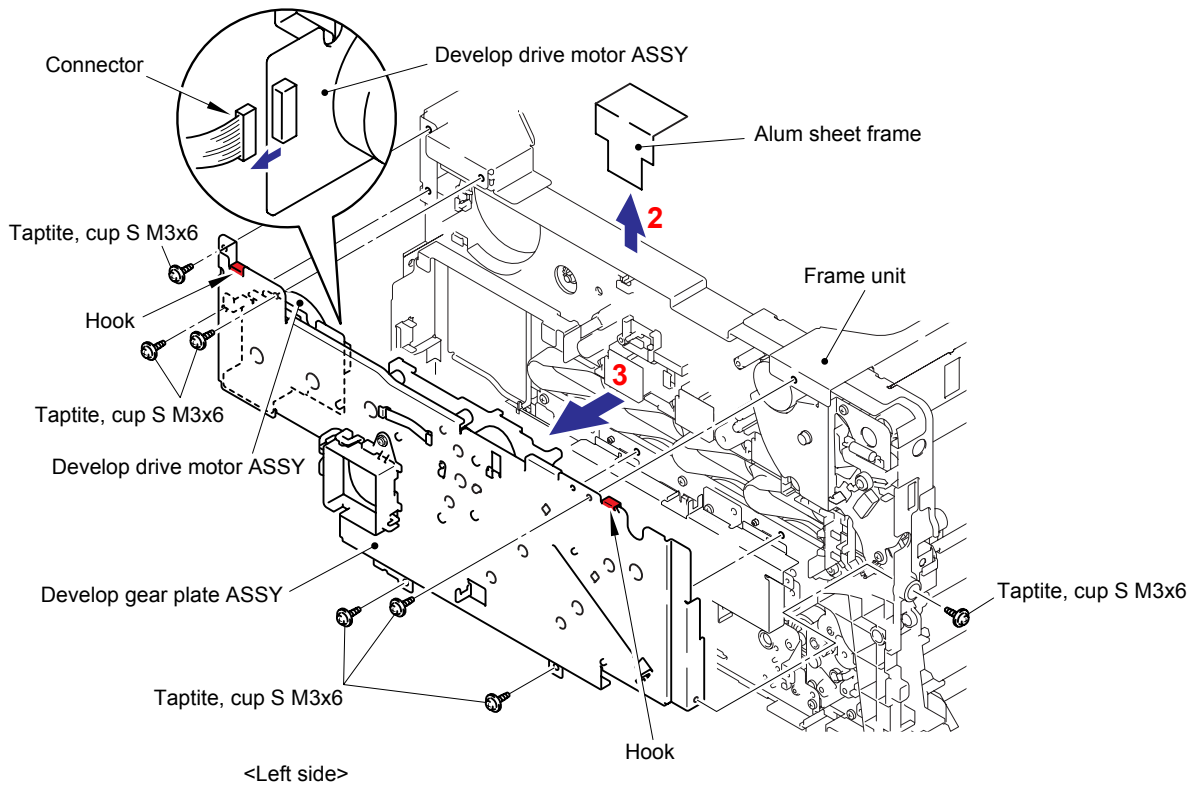

Fig. 3-165

- (4) Remove the three cup S M3x6 Taptite screws, and then remove the Develop drive motor ASSY from the Develop gear plate ASSY.

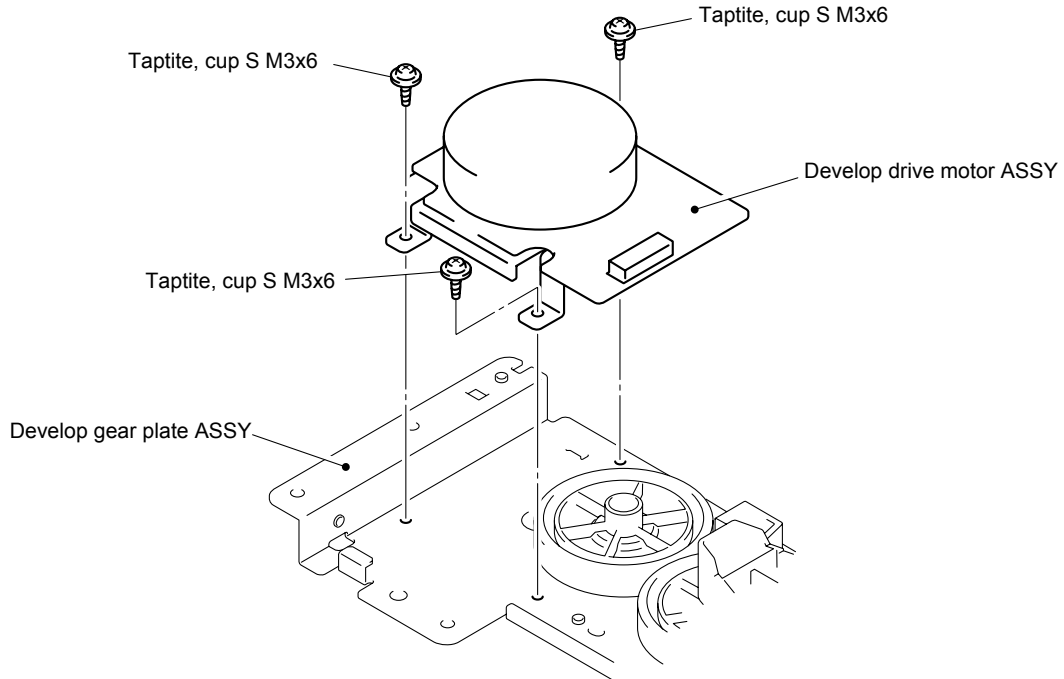

Fig. 3-166

- (5) Remove the five cup B M3x10 Taptite screws, and then remove the Gear guide holder from the Develop gear plate ASSY.

Note:

Since the gears on the Gear guide holder and the Coupling gears 50 on the Develop gear plate ASSY come off easily, be careful not to lose them.

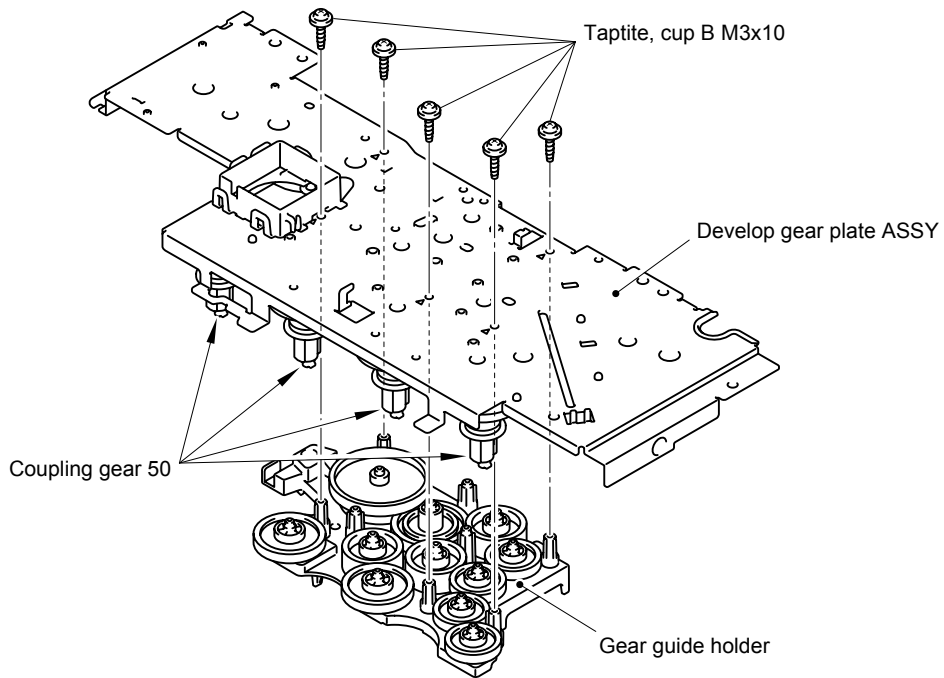

Fig. 3-167

(6) Remove the Friction cap from the Develop gear plate ASSY.

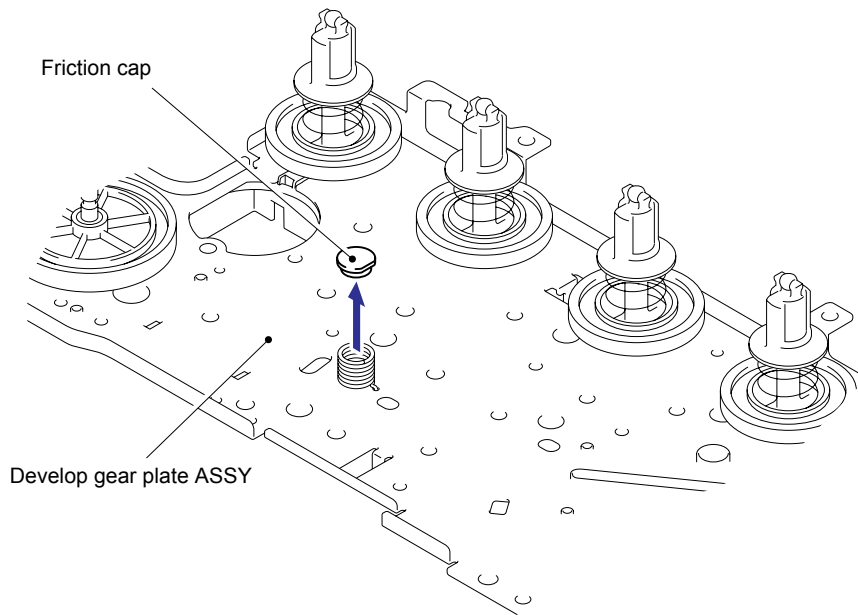

Fig. 3-168

Assembling Note:

- When assembling the Develop gear plate ASSY onto the Frame unit, secure the screws in the order of the numbers which are indicated on the plate.

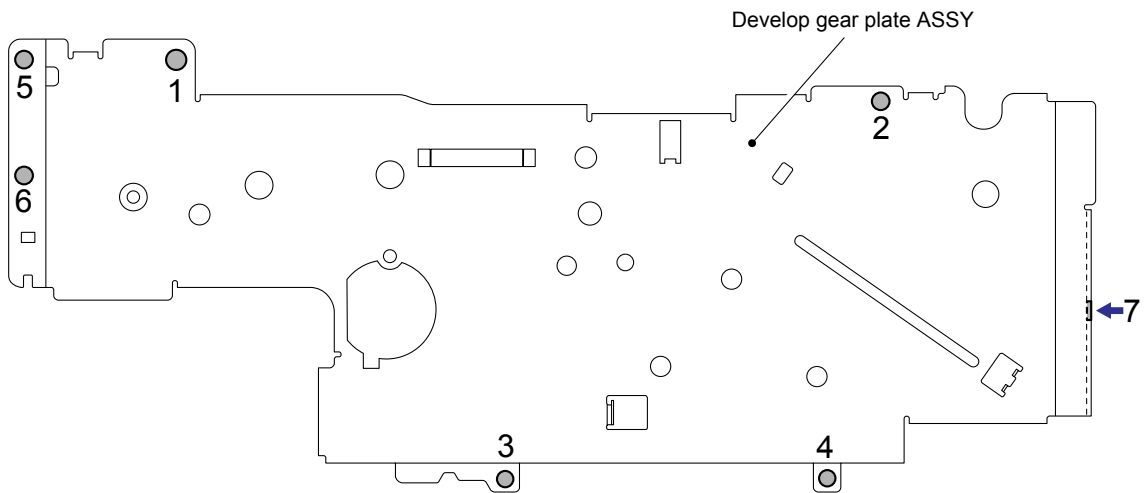

Fig. 3-169

Assembling Note:

- When assembling the Develop gear plate ASSY, make sure to keep the Harness and Flat cable out of the Frame unit to prevent them from going into the Develop gear plate ASSY.

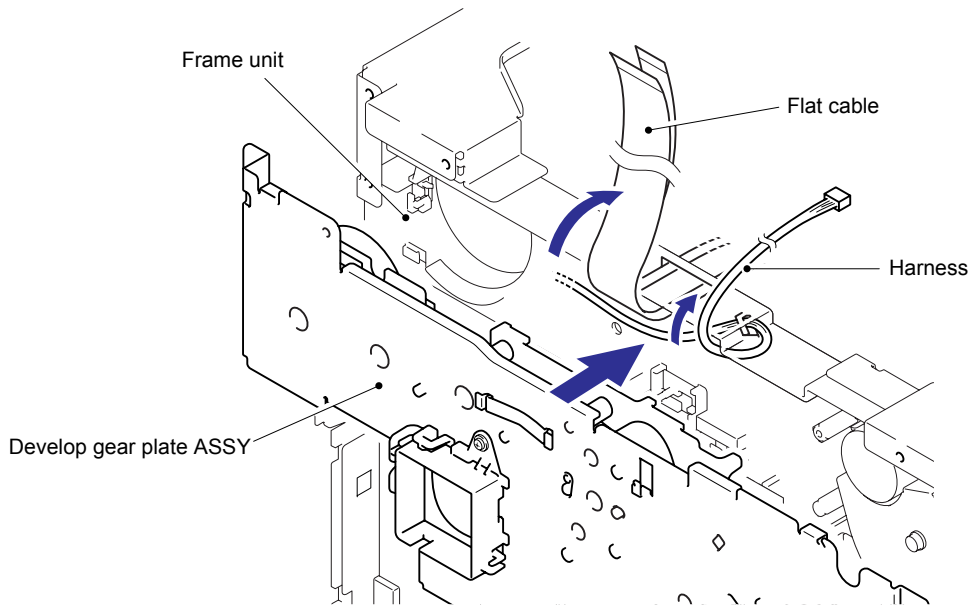

Fig. 3-170

- If the Joint release lever is protruding from the Develop gear plate ASSY, push the Joint release lever back into the inside of the Develop gear plate ASSY.

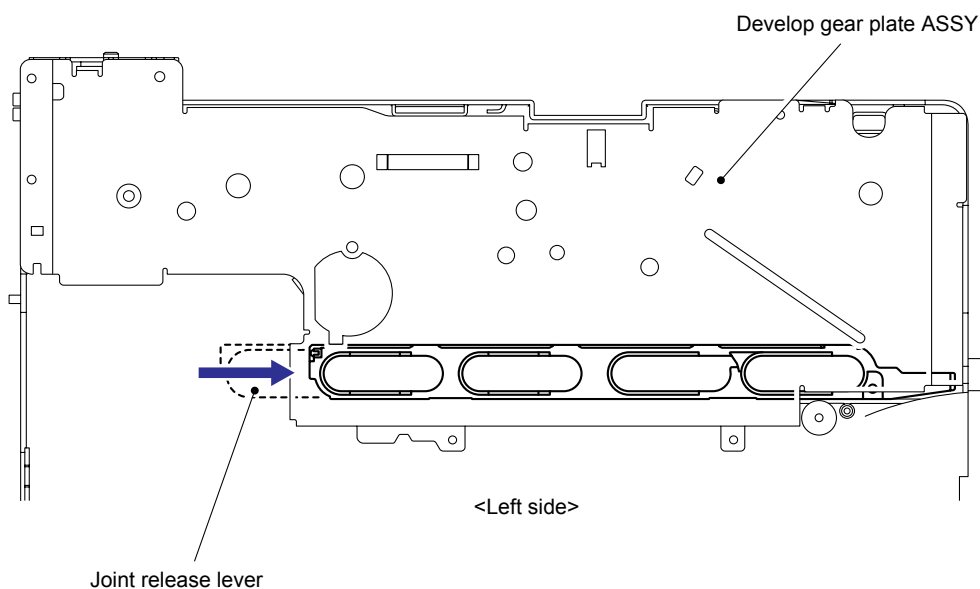

Fig. 3-171

Assembling Note:

- Always make sure to attach the Alum sheet frame after assembling the Develop gear plate ASSY and Flat cable. Attach the Alum sheet frame so that it is aligned with the corner of the square hole as shown in the figure below.

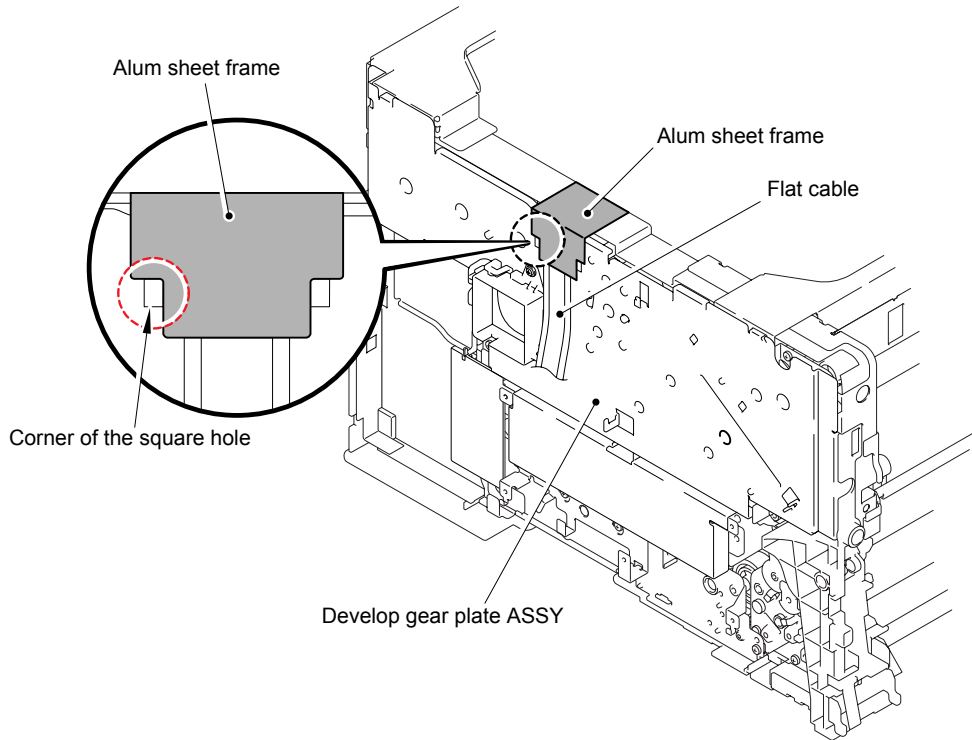

Fig. 3-172

8.39 Drum Drive ASSY/ Drum Phase Sensor PCB ASSY 1, 2

- (1) Remove the Engine insulation sheet from the Harness shield plate, which is fixed with a two-sided adhesive tape.

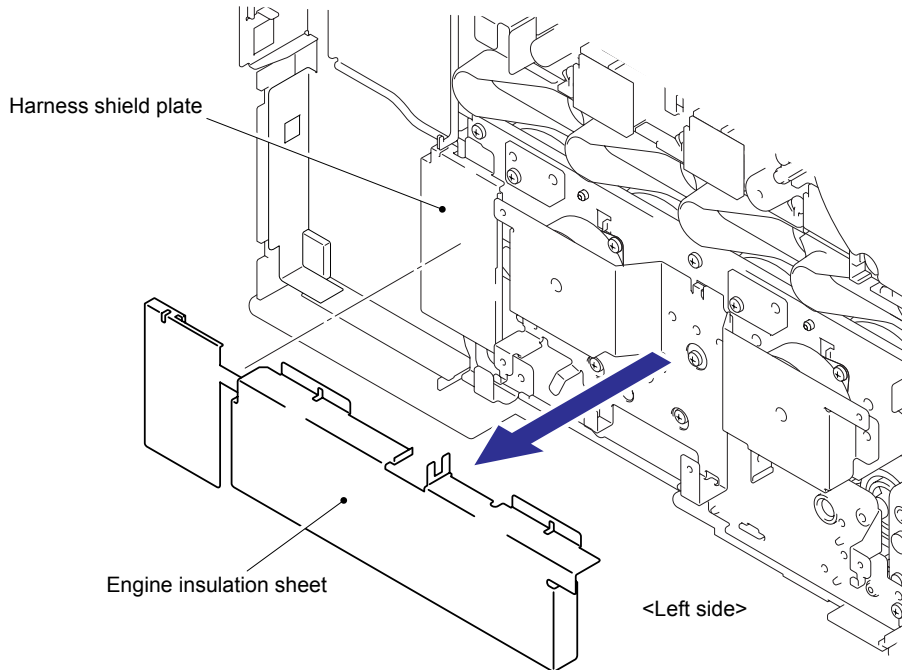

Fig. 3-173

- (2) Remove the three cup S M3x6 Taptite screws, and then remove the Harness shield plate from the Frame unit.

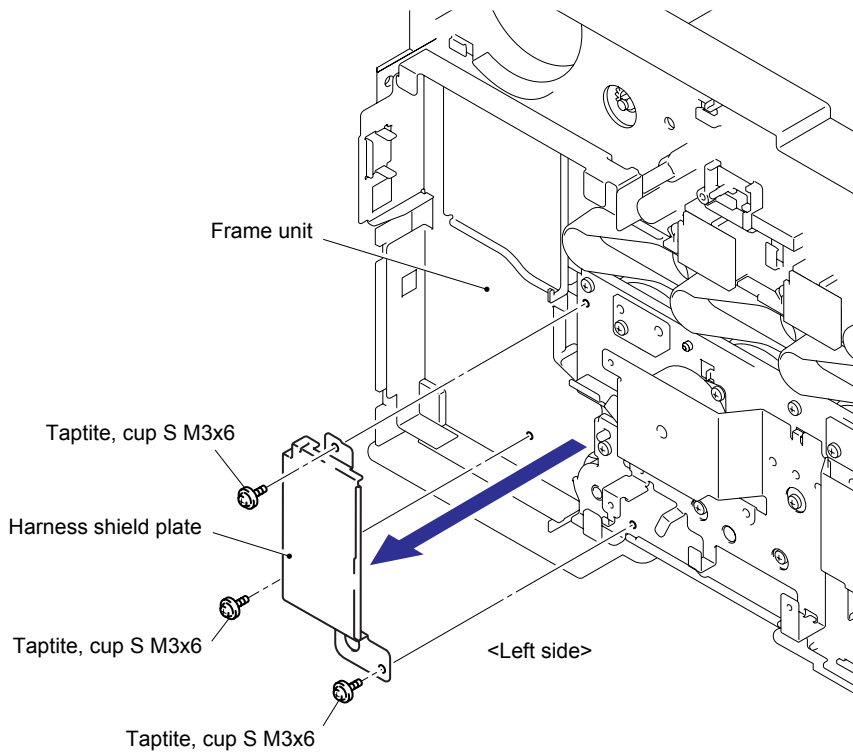

Fig. 3-174

(3) Remove the four cup S M3x6 Taptite screws, and then remove the Engine PCB plate.

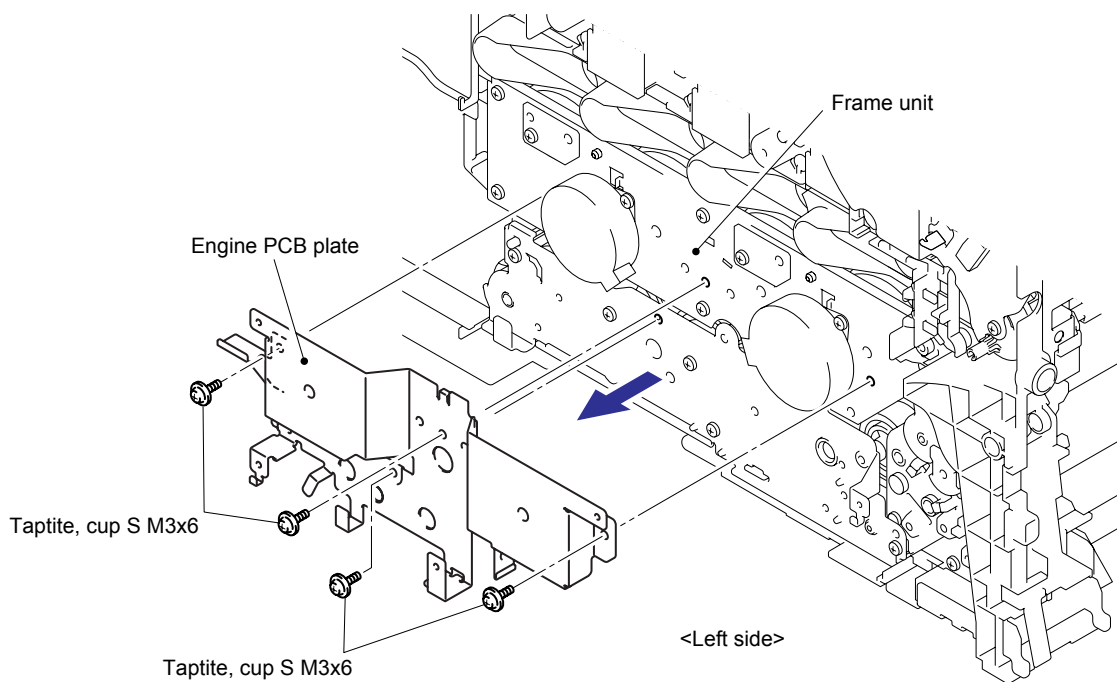

Fig. 3-175

Assembling Note:

When assembling the Engine PCB plate, make sure that the section "A" is caught on the Hook of the Drive frame unit ASSY.

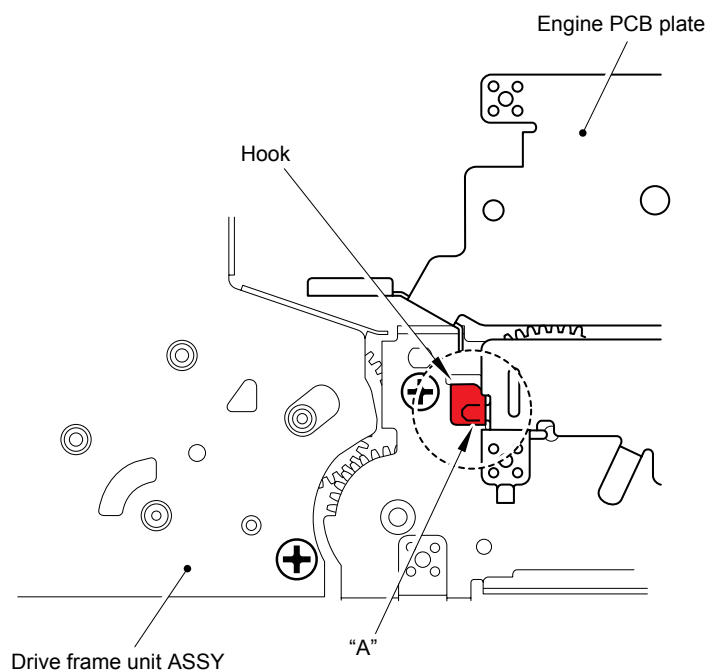

Fig. 3-176

- (4) Remove the two cup S M3x6 Taptite screws, and then remove the Drum drive motor 1.
- (5) Remove the two cup S M3x6 Taptite screws, and then remove the Drum drive motor 2.

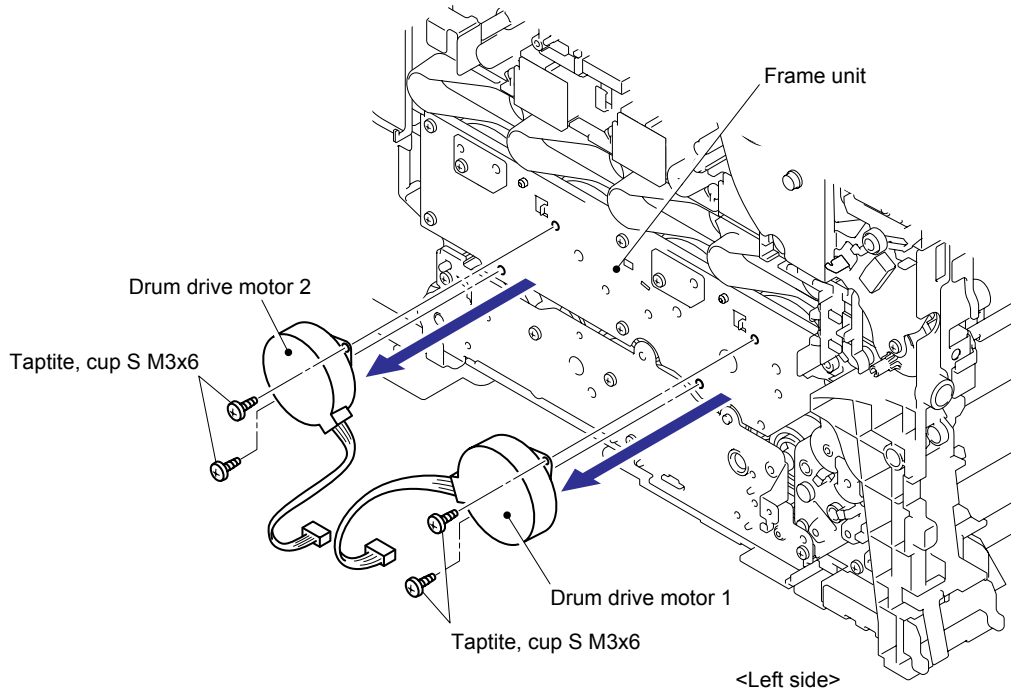
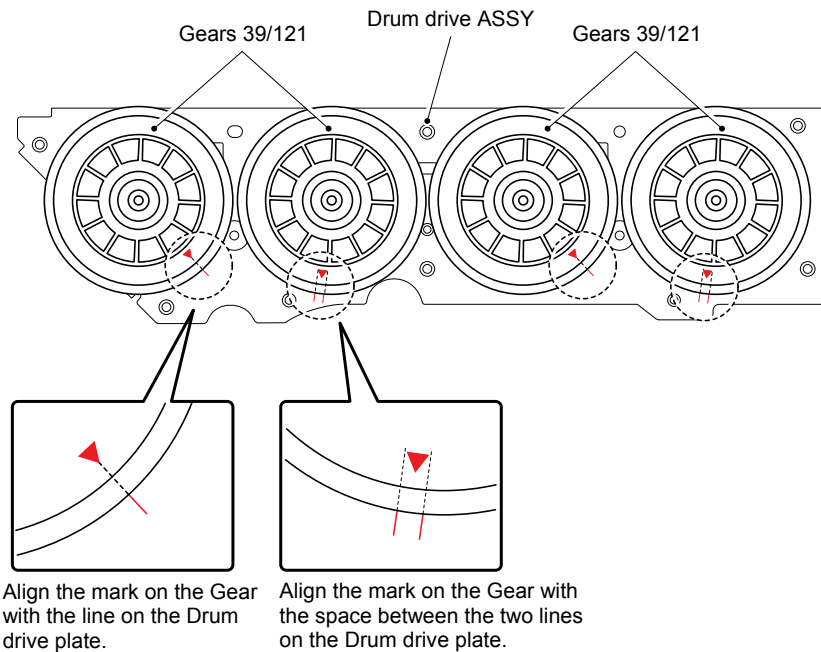

Fig. 3-177

Assembling Note:

The two Gears 39/121 which are engaged with the same motor are phased with each other when assembling the Drum drive ASSY. If removing the motor to replace it, the gears may be out of phase. When replacing the motor, therefore, be sure to phase the Gears 39/121, and then assemble the motor. For the method how to phase the gears, refer to the figure below (Fig. 3-178).



Align the mark on the Gear with the line on the Drum drive plate.

Align the mark on the Gear with the space between the two lines on the Drum drive plate.

Fig. 3-178

- (6) Remove the six bind B M4x12 Taptite screws, and then remove the Drum drive ASSY from the Frame unit.

Note:

Since the four Gears 39/121 of the Drum drive ASSY are assembled together, which makes one set, DO NOT replace only one gear. If their replacement is required, replace the complete Drum drive ASSY.

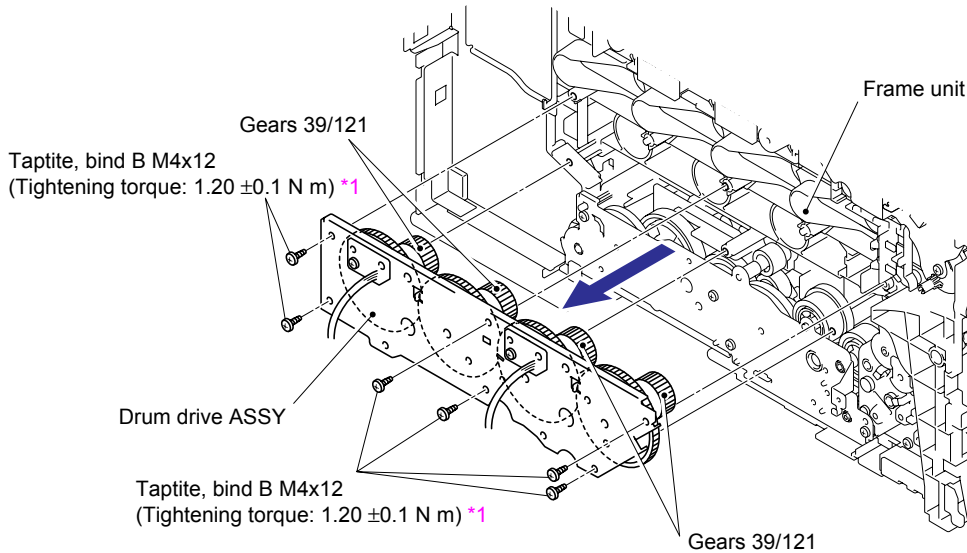

Fig. 3-179

<Left side>

***1 Tightening Note:**

When tightening the screw, slowly turn it counterclockwise (in the direction to loosen the screw) with your hand until you feel that the screw is a little dropped in the hole. Then, slightly turn it clockwise (in the direction to tighten the screw) with your hand and tighten it according to the specified torque with a screwdriver.

- (7) Remove the bind S M3x6 Taptite screw, and then remove the Drum phase sensor PCB ASSY 2 (whose harness is longer) from the Drum drive ASSY.

- (8) Remove the Drum phase sensor PCB 1 (whose harness is shorter) in the same way.

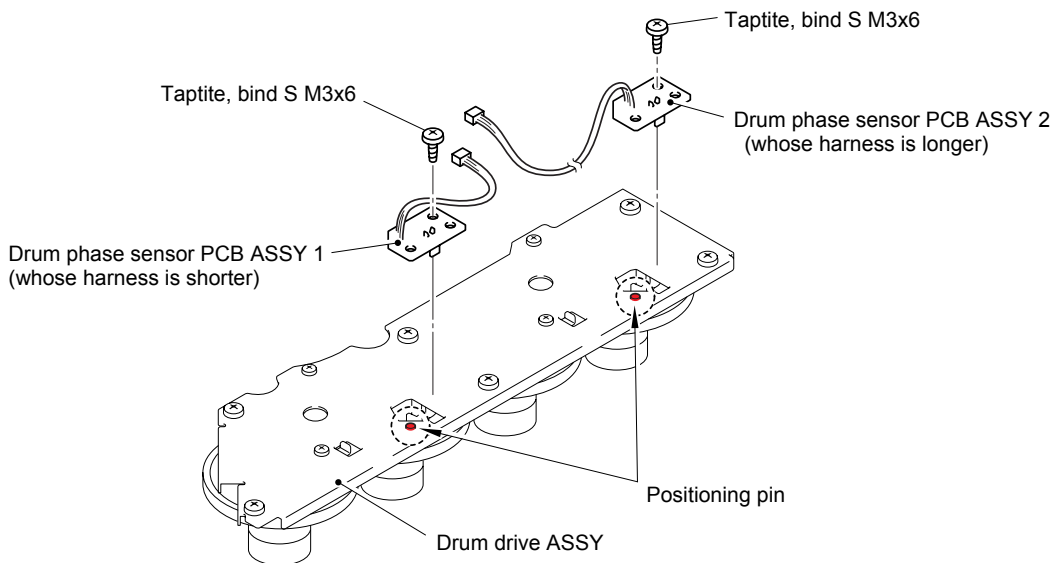

Fig. 3-180

8.40 Drive Frame Unit ASSY

- (1) Remove the three bind B M4x12 Taptite screws, and then remove the Drive frame unit ASSY from the Frame unit.
- (2) Disconnect the Connector from the Drive frame unit ASSY.

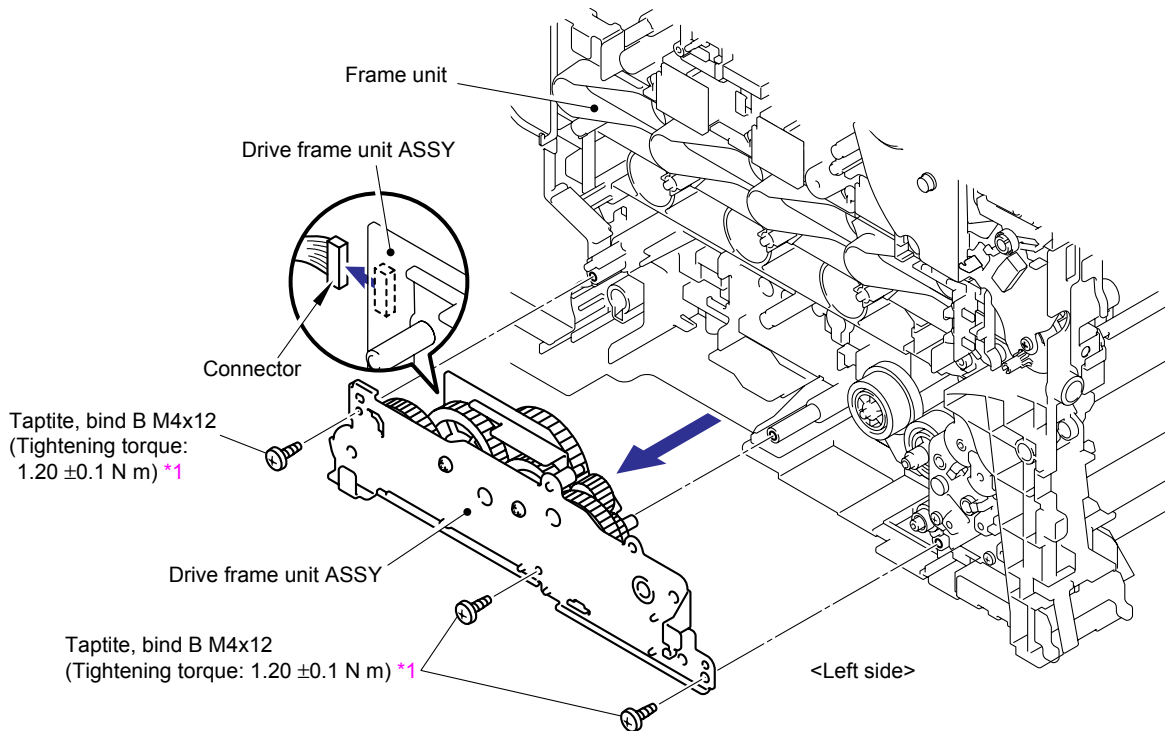

Fig. 3-181

*1 Tightening Note:

When tightening the screw, slowly turn it counterclockwise (in the direction to loosen the screw) with your hand until you feel that the screw is a little dropped in the hole. Then, slightly turn it clockwise (in the direction to tighten the screw) with your hand and tighten it according to the specified torque with a screwdriver.

8.41 Paper Feed/Belt Cleaner Motor ASSY

- (1) Remove the four cup S M3x6 Taptite screws (2 pieces provided on each of the front and back), and then remove the Paper feed/belt cleaner motor ASSY from the Drive frame unit ASSY.

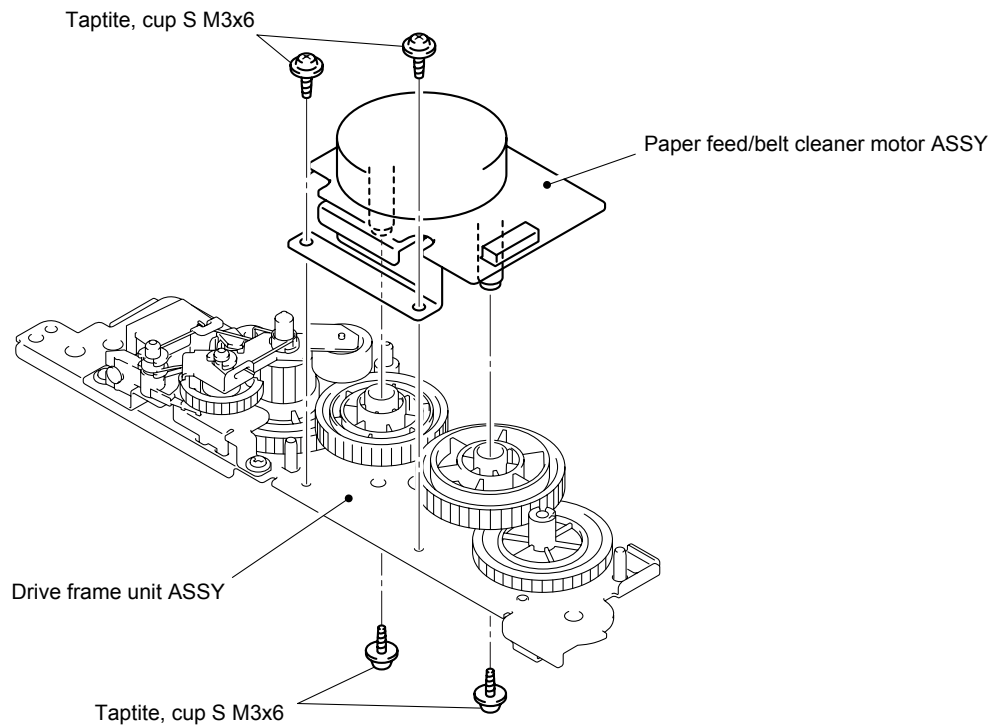

Fig. 3-182

Assembling Note:

Be sure to hook the harness of the Paper feed/belt cleaner motor ASSY onto the Rib of the Frame L as shown in the figure below.

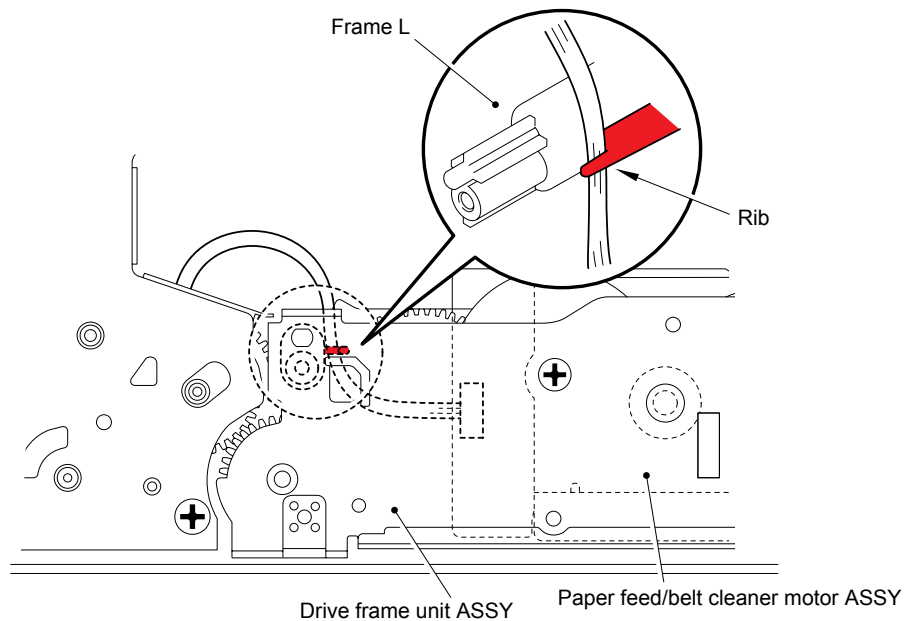

Fig. 3-183

8.42 Develop Release Sensor PCB ASSY

- (1) Remove the cup B M3x8 Taptite screw.
- (2) Remove the Develop release sensor PCB ASSY from the Frame unit. Disconnect the Connector from the Develop release sensor PCB ASSY.

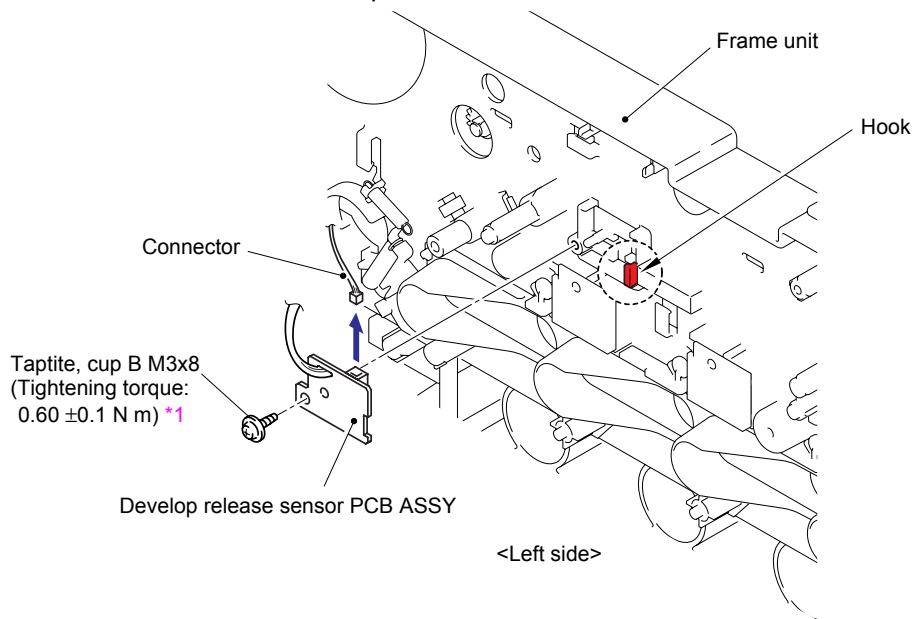

Fig. 3-184

*1 Tightening Note:

When tightening the screw, slowly turn it counterclockwise (in the direction to loosen the screw) with your hand until you feel that the screw is a little dropped in the hole. Then, slightly turn it clockwise (in the direction to tighten the screw) with your hand and tighten it according to the specified torque with a screwdriver.

8.43 Develop Press Drive L ASSY

- (1) Remove the Pull up lever spring (for L) from the Hook of Develop press drive L ASSY.

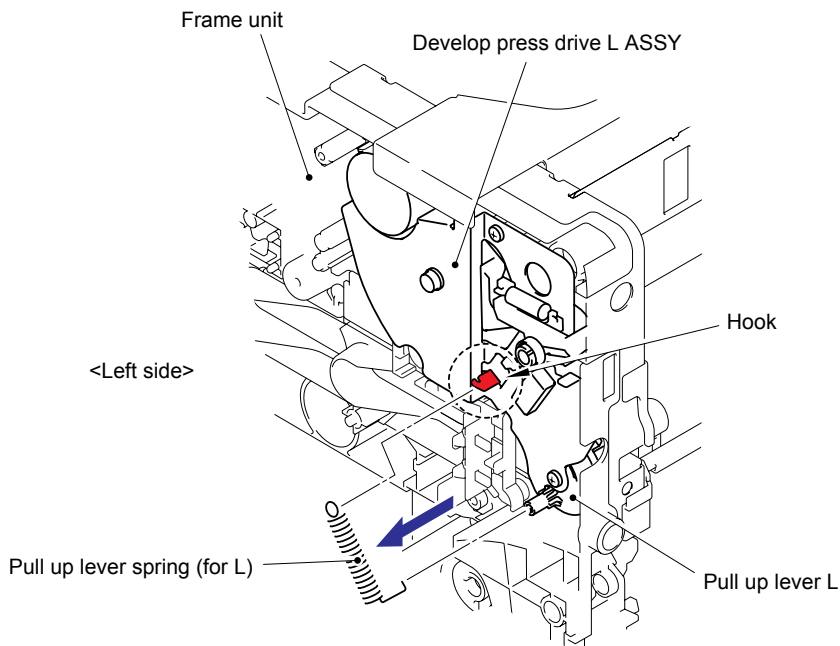

Fig. 3-185

- (2) Remove the three bind B M3x12 Taptite screws and cup B M3x12 Taptite screw, and then remove the Develop press drive L ASSY.

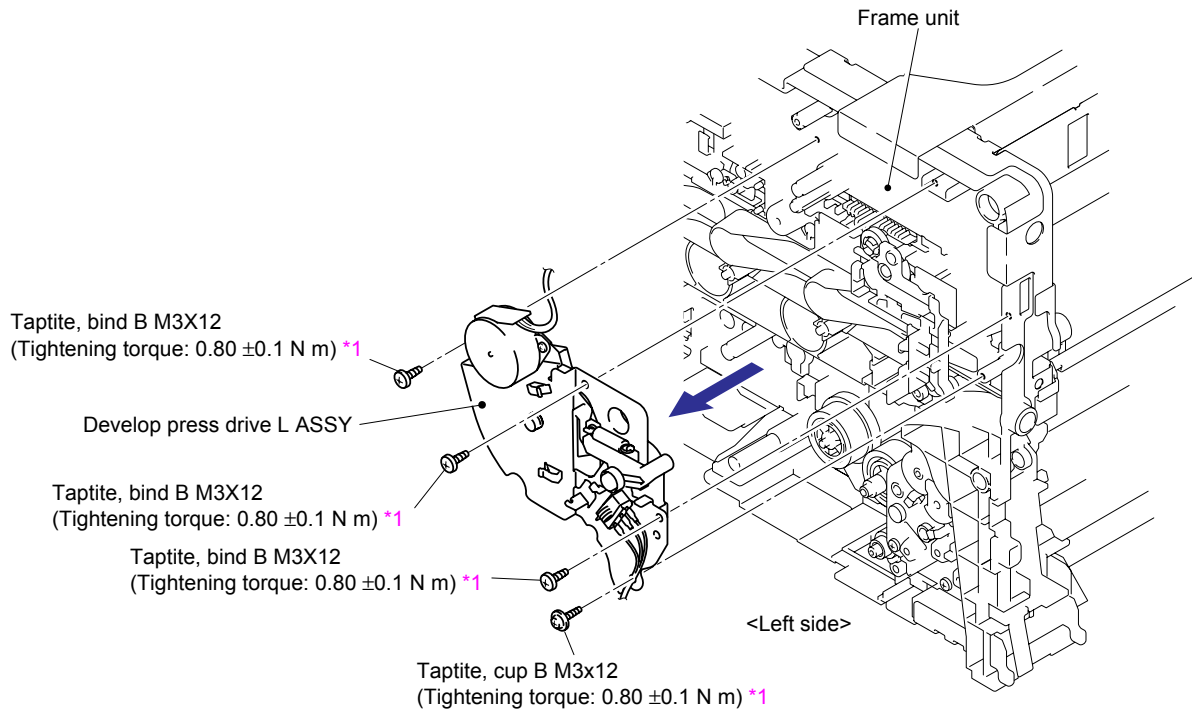

Fig. 3-186

***1 Tightening Note:**

When tightening the screw, slowly turn it counterclockwise (in the direction to loosen the screw) with your hand until you feel that the screw is a little dropped in the hole. Then, slightly turn it clockwise (in the direction to tighten the screw) with your hand and tighten it according to the specified torque with a screwdriver.

- (3) Remove the bind S M3x6 Taptite screw, and then remove the Develop release motor ASSY from the Develop press drive L ASSY.

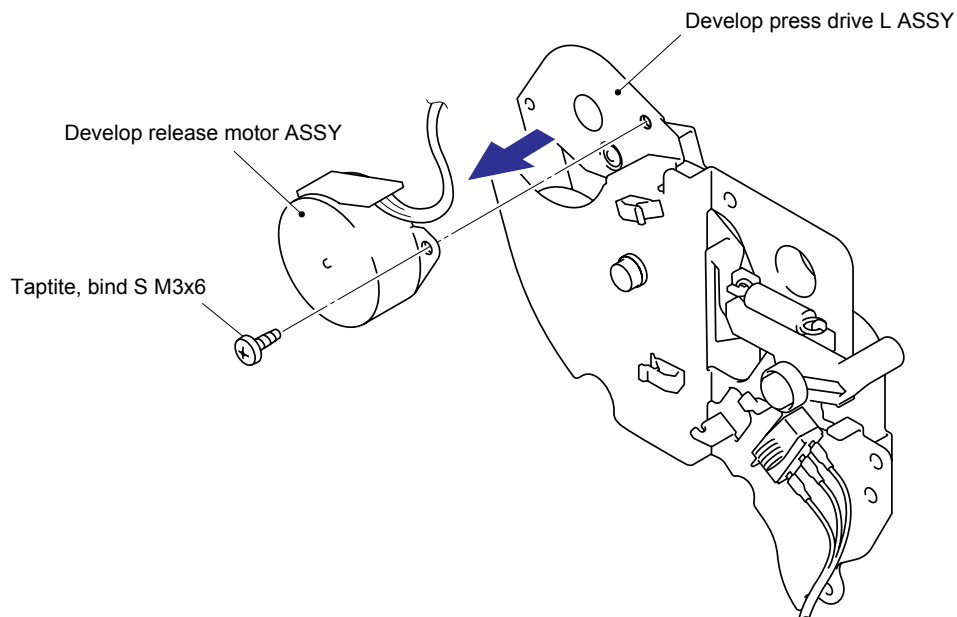

Fig. 3-187

Assembling Note:

- Assemble the Develop press drive L ASSY so that the section of the Pull up lever L, where the spring is hooked is placed as shown in the figure below.

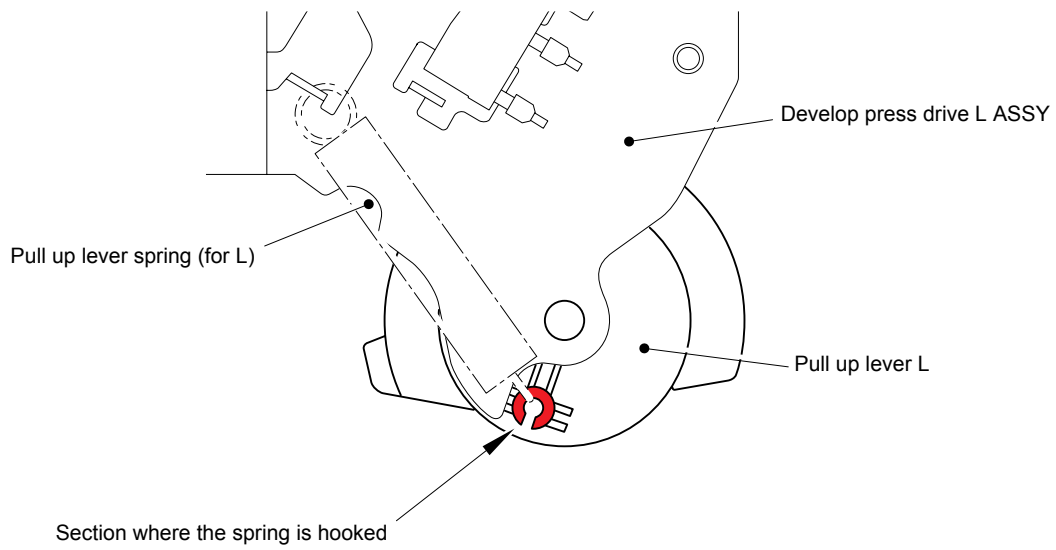

Fig. 3-188

- Catch the harness from the Laser unit onto the Hook as shown in the figure below, and then assemble the Develop press drive L ASSY.

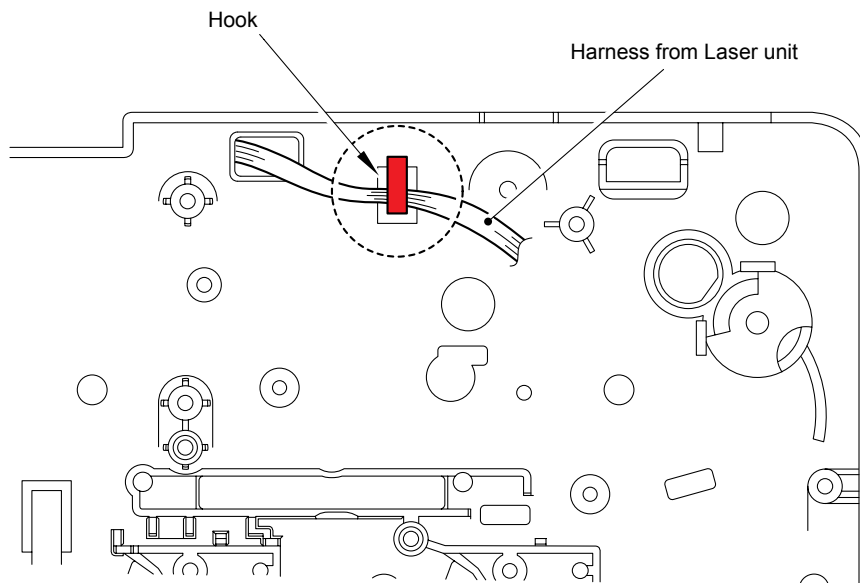

Fig. 3-189

8.44 Front Cover Interlock Switch ASSY

- (1) Remove the Interlock switch holder spring and Interlock harness guide from the Develop press drive L ASSY.

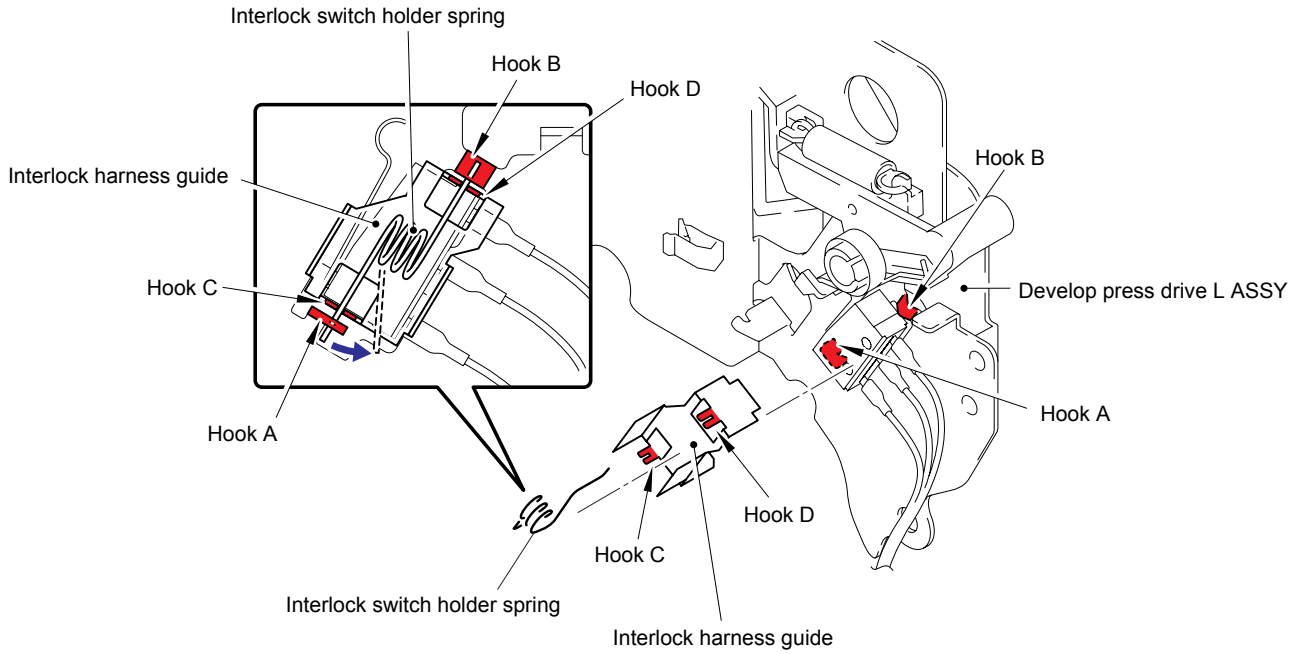

Fig. 3-190

- (2) Remove the Front cover interlock switch ASSY from the Develop press drive L ASSY.

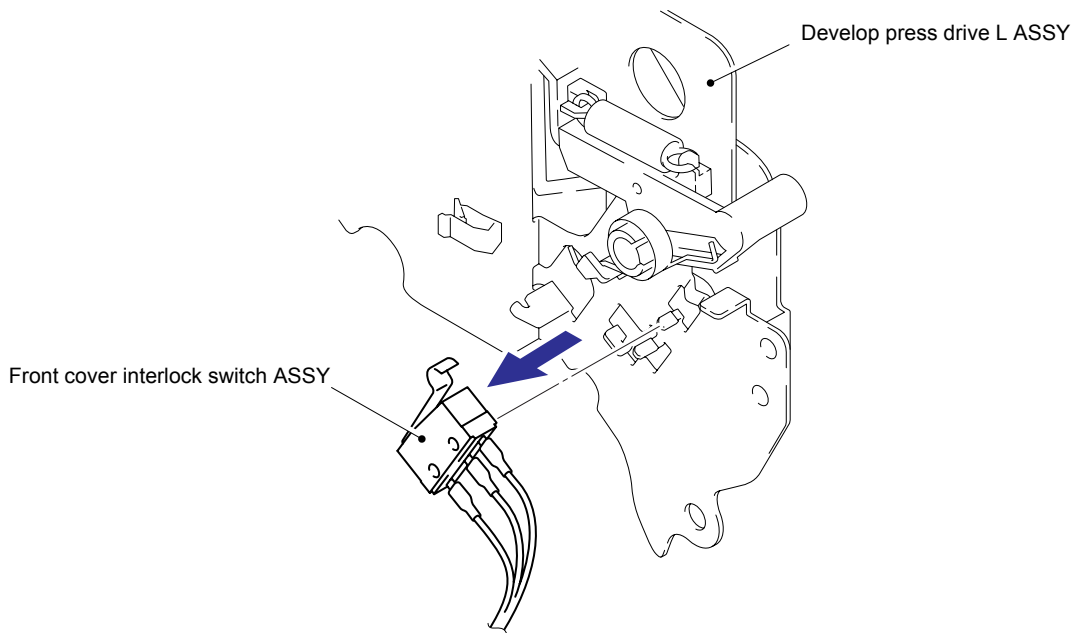

Fig. 3-191

8.45 Toner Sensor PCB ASSY K, Y, M, C (TE/NEW)

- (1) Remove the three cup B M3x10 Taptite screws, and then remove the Release drive holder from the Frame unit.

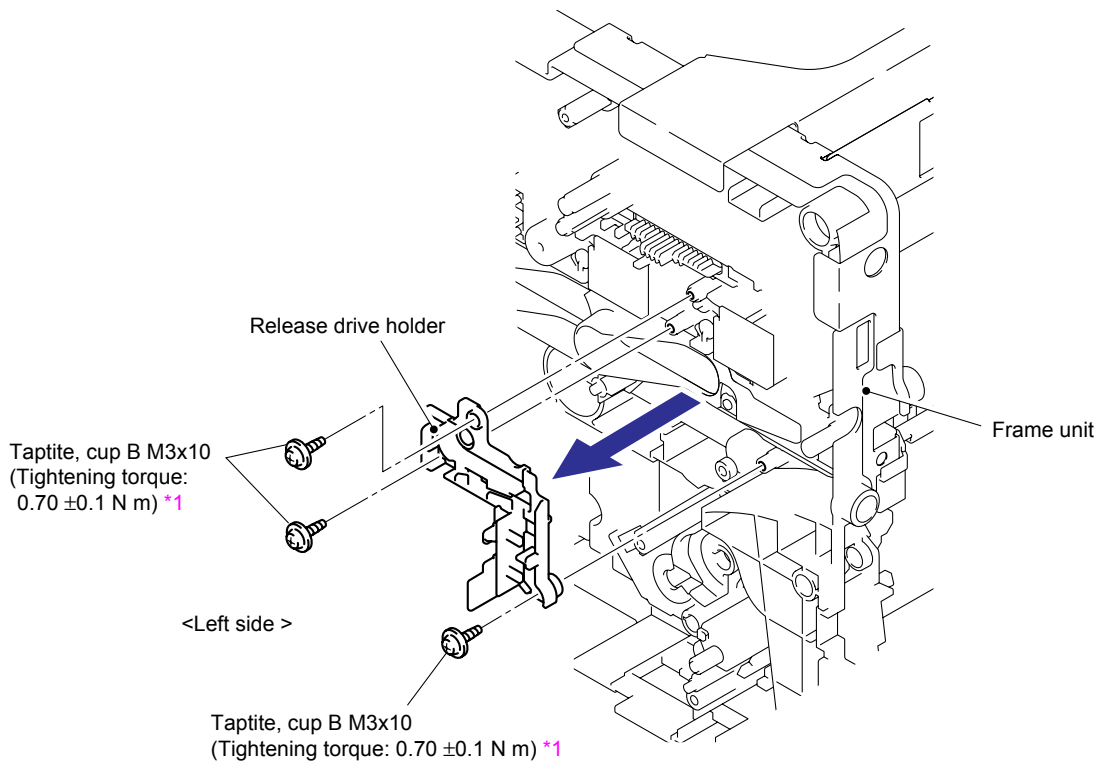

Fig. 3-192

***1 Tightening Note:**

When tightening the screw, slowly turn it counterclockwise (in the direction to loosen the screw) with your hand until you feel that the screw is a little dropped in the hole. Then, slightly turn it clockwise (in the direction to tighten the screw) with your hand and tighten it according to the specified torque with a screwdriver.

- (2) Remove the bind B M3x8 Taptite screw, and then remove the Toner sensor PCB ASSY K (TE/NEW) from the Frame unit.
- (3) Remove the cup B M3x8 Taptite screw, and then remove the TE protect film 2 and Toner sensor PCB ASSY Y (TE/NEW) from the Frame unit.
- (4) Remove the bind B M3x8 Taptite screw, and then remove the Toner sensor PCB ASSY M (TE/NEW) from the Frame unit.
- (5) Remove the bind B M3x8 Taptite screw, and then remove the Toner sensor PCB ASSY C (TE/NEW) from the Frame unit.

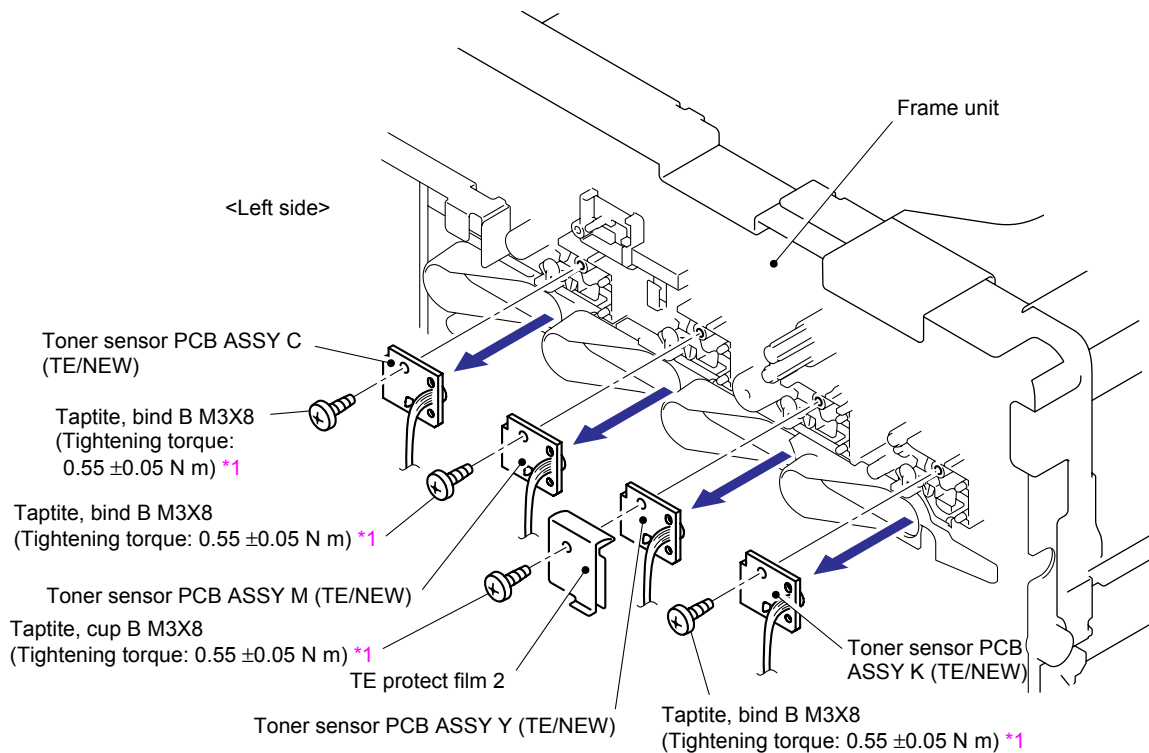

Fig. 3-193

***1 Tightening Note:**

When tightening the screw, slowly turn it counterclockwise (in the direction to loosen the screw) with your hand until you feel that the screw is a little dropped in the hole. Then, slightly turn it clockwise (in the direction to tighten the screw) with your hand and tighten it according to the specified torque with a screwdriver.

Assembling Note:

Assemble the Toner sensor PCB ASSY K, Y, M, C (TE/NEW) as shown in the figure below. For the method to arrange the harnesses, refer to "5. Toner sensor PCB ASSY K, Y, M, C (TE/NEW)".

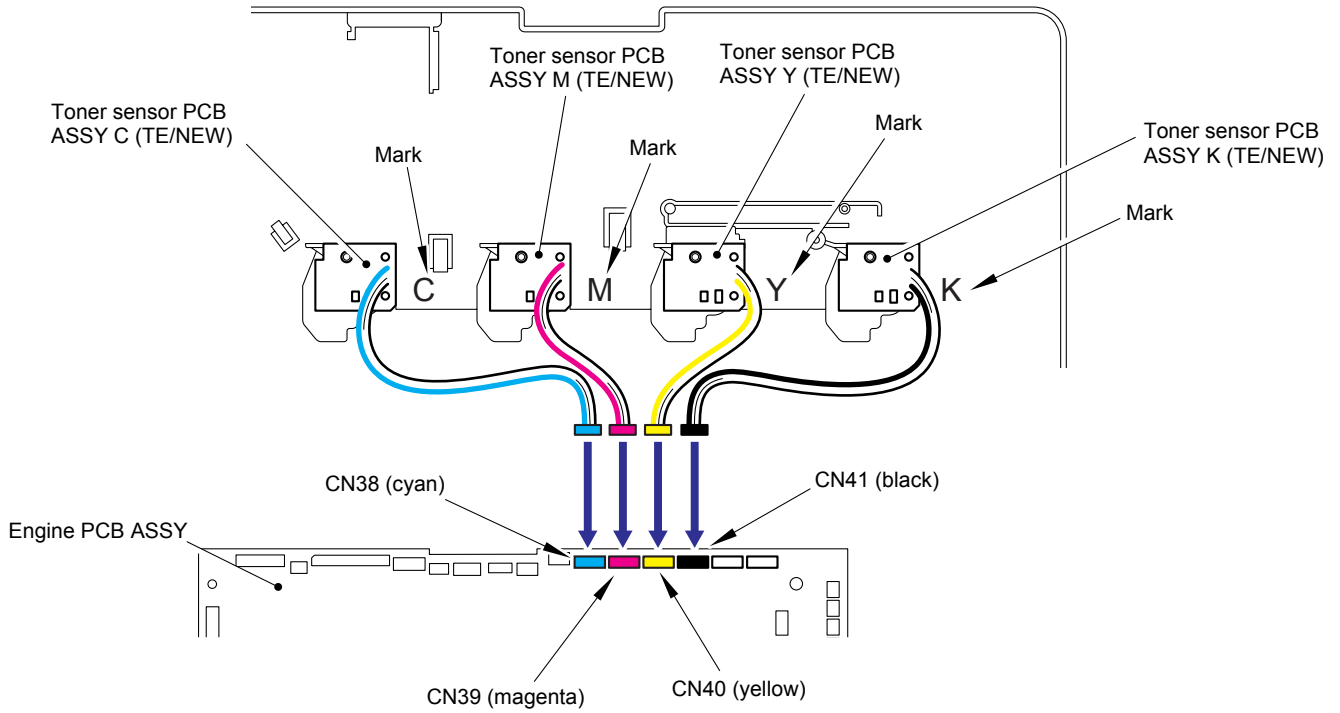

Fig. 3-194

- (6) Release the two Hooks of the LED holder to remove it from each of the four Toner sensor PCB ASSYs (TE/NEW).

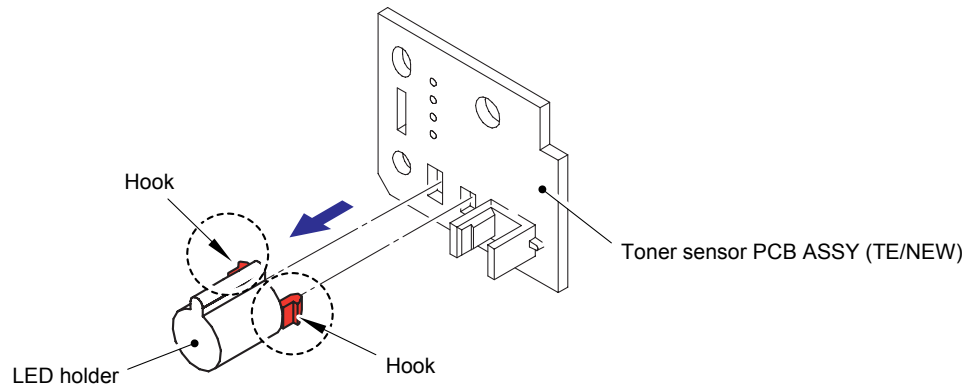

Fig. 3-195

Assembling Note:

Assemble the Toner sensor PCB ASSY (TE/NEW) so that the Shutter of the New toner actuator is put into the sensor section of the Toner sensor PCB ASSY (TE/NEW).

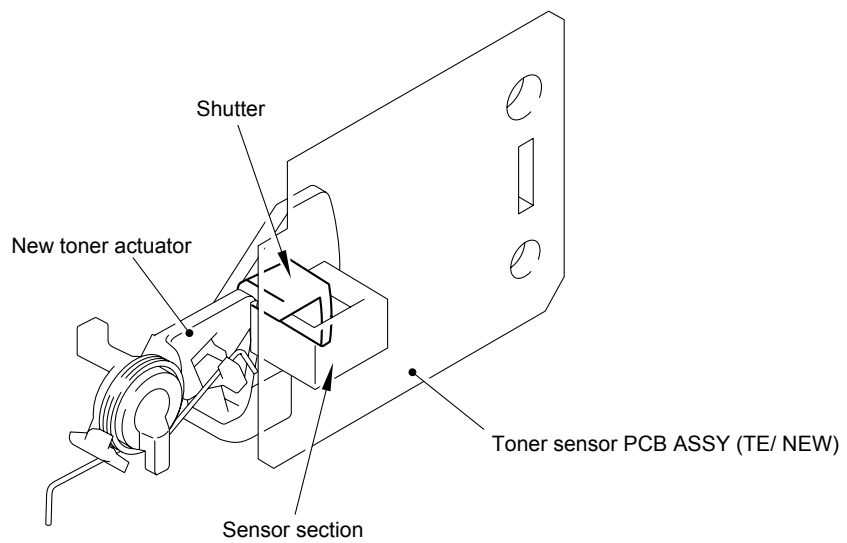

Fig. 3-196

8.46 New Toner Actuator/ New Toner Actuator Spring

- (1) Release the section "A" of the New toner actuator spring from the Hook of the Frame unit, and then remove the New toner actuator from the Fame unit.

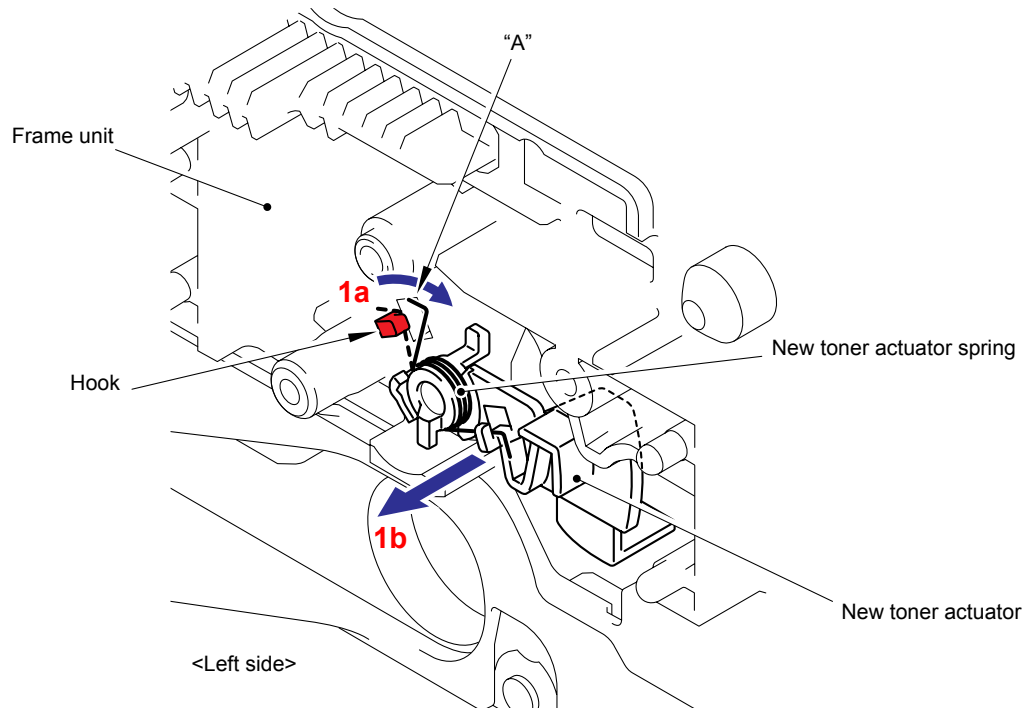

Fig. 3-197

- (2) Remove the New toner actuator spring from the New toner actuator.

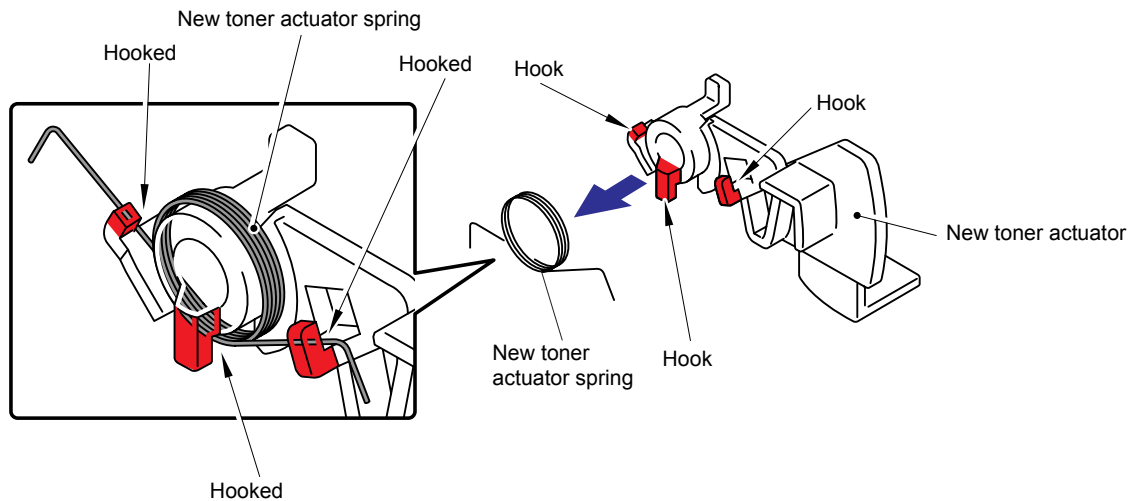

Fig. 3-198

8.47 Side Plate R ASSY

- (1) Remove the four cup S M3x6 Taptite screws, four cup B M4x12 Taptite screws and screw pan (S/P washer) M4x8.
- (2) Remove the cup S M4x8 Taptite screw and screw pan (S/P washer) M4x8, and then remove the Side plate R ASSY from the Frame unit.

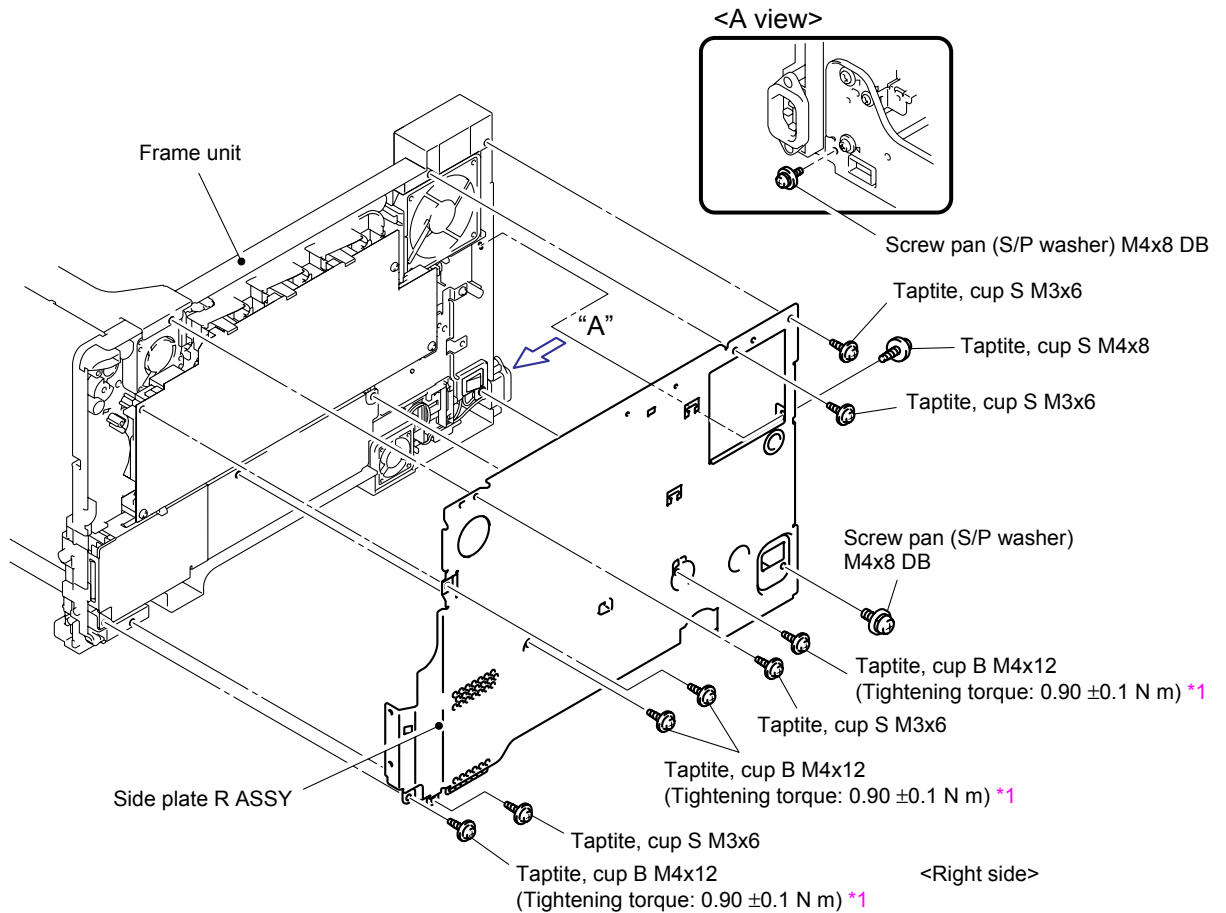

Fig. 3-199

***1 Tightening Note:**

When tightening the screw, slowly turn it counterclockwise (in the direction to loosen the screw) with your hand until you feel that the screw is a little dropped in the hole. Then, slightly turn it clockwise (in the direction to tighten the screw) with your hand and tighten it according to the specified torque with a screwdriver.

8.48 Drum Lock Lever L

- (1) Remove the Screw, bind M3x8, and remove the Drum lock lever plate L ASSY and then remove the Drum lock spring and Drum lock lever L from the Frame unit.

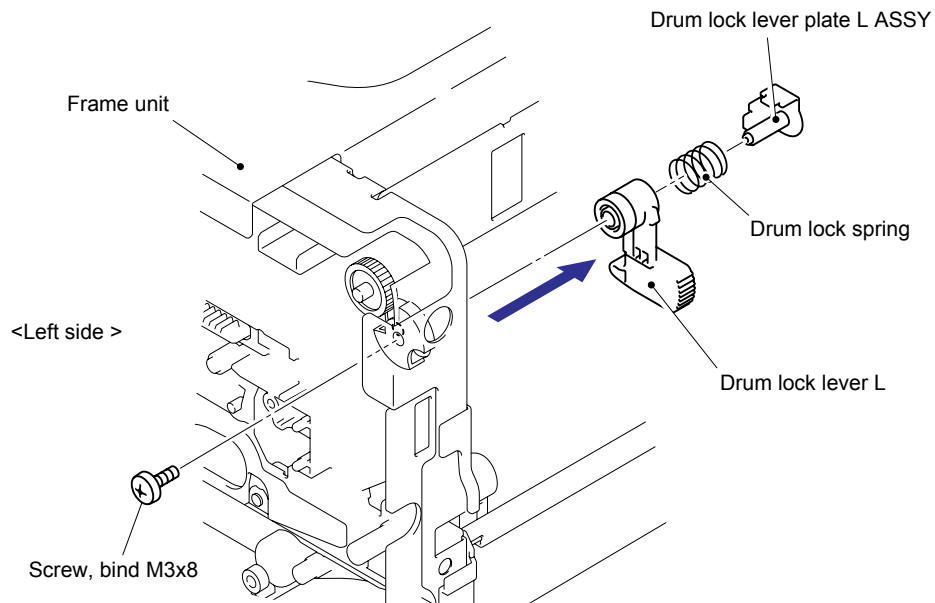

Fig. 3-200

Assembling Note:

Assemble the Drum lock lever so that both Drum lock lever R and L are in the same direction.

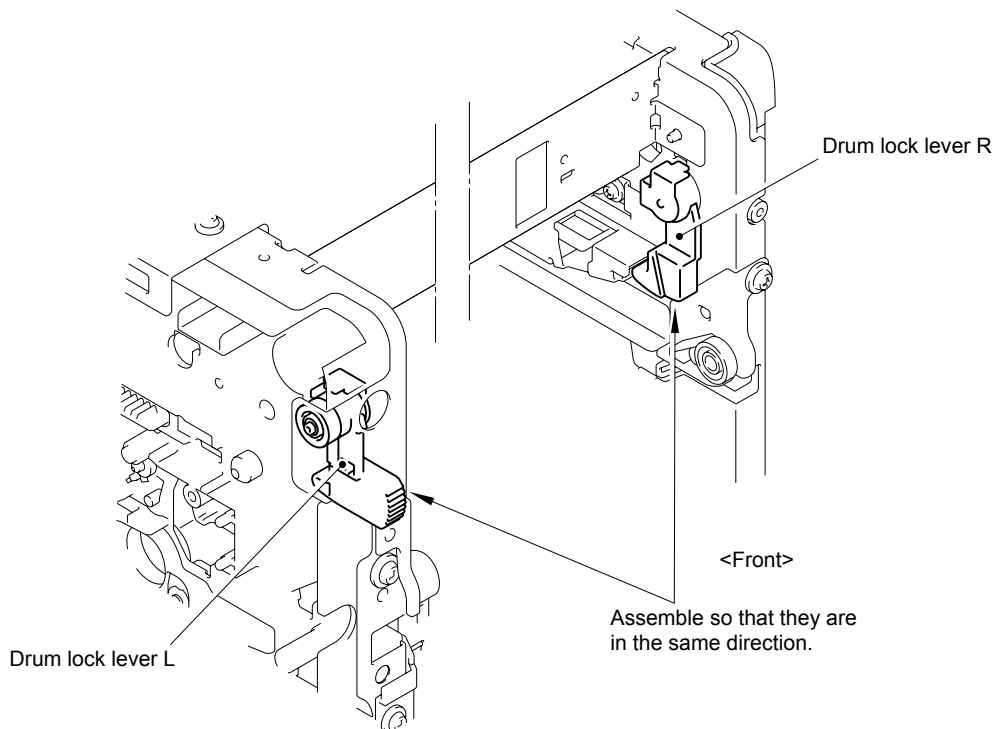

Fig. 3-201

8.49 Drum Lock Lever R

- (1) Remove the Screw, bind M3x8, and remove the Drum lock lever plate R ASSY and then remove the Drum lock lever R from the Frame unit.

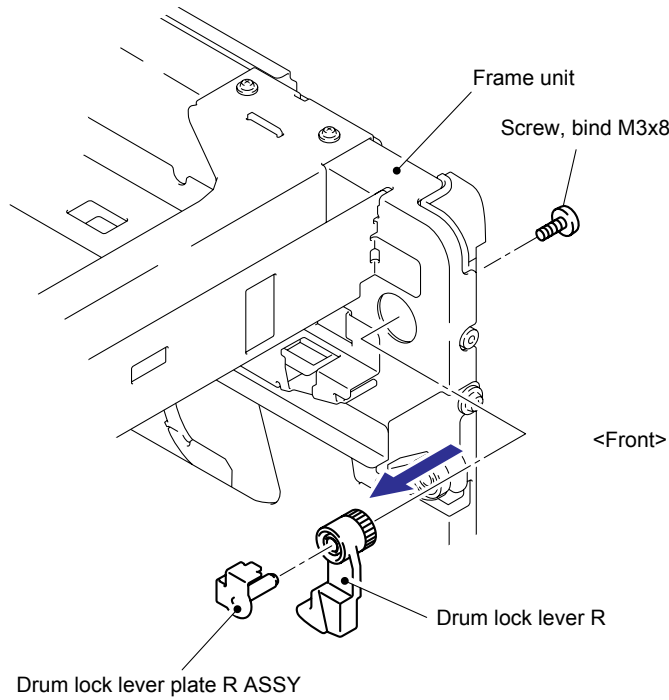

Fig. 3-202

Assembling Note:

Assemble the Drum lock lever so that both Drum lock lever R and L are in the same direction.

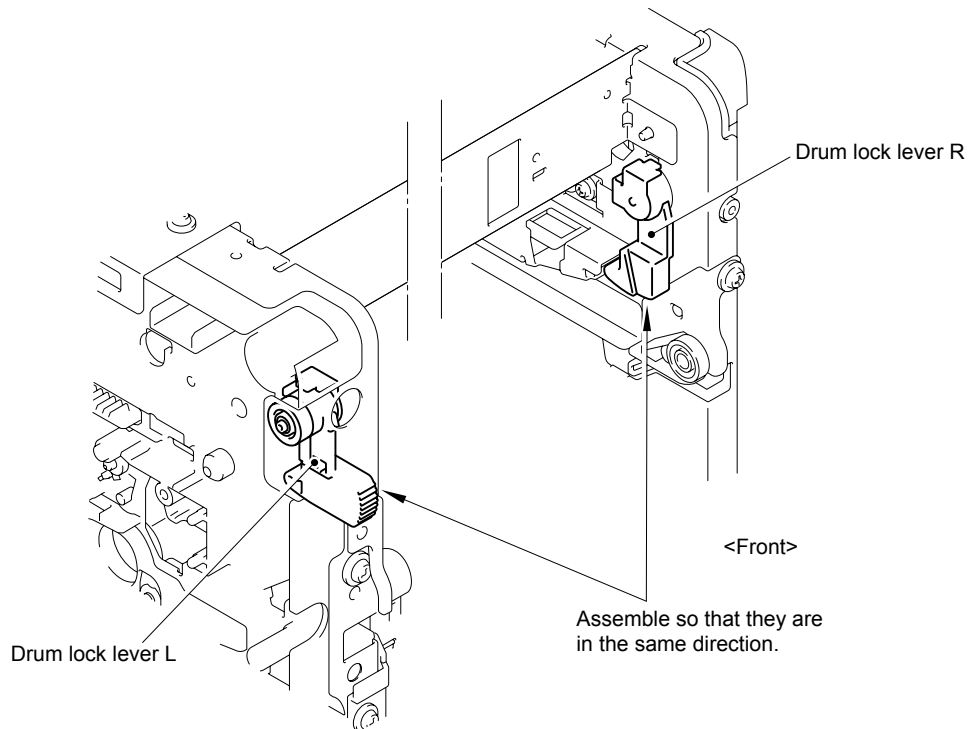

Fig. 3-203

Assembling Note:

- Be careful not to loose the HVPS charge head, HVPS charge head spring, HVPS DEV head and HVPS DEV head spring. Before assembling the Charge HVPS PCB ASSY, check that these four parts are complete, and that they move smoothly.

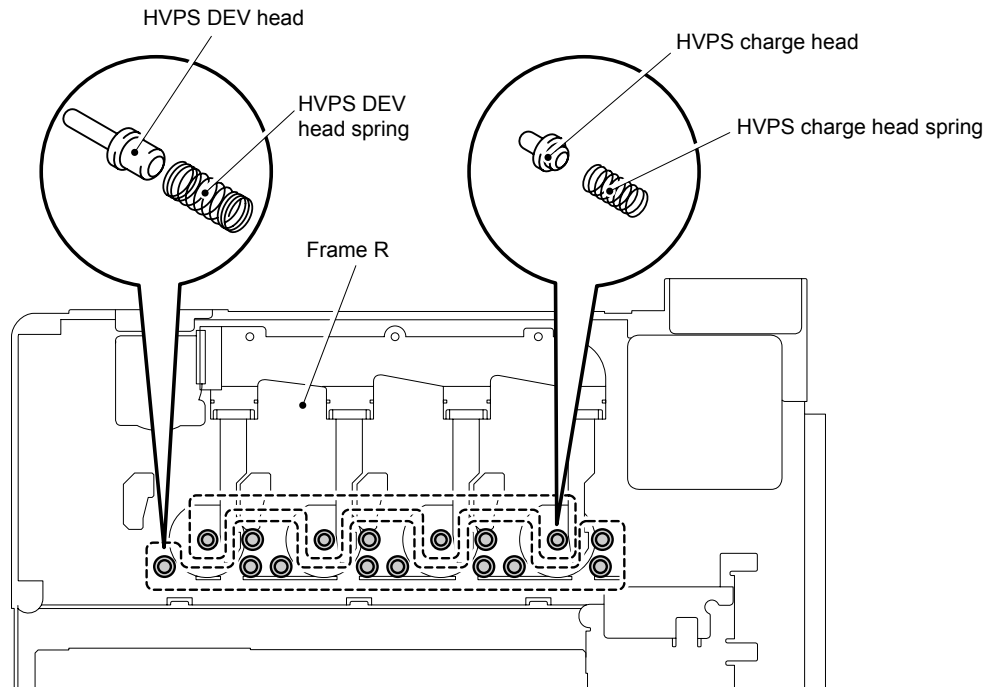

Fig. 3-206

- When assembling the Charge HVPS PCB ASSY, be careful not to catch the harness of the Air intake fan (AIR) in the Charge HVPS PCB ASSY.

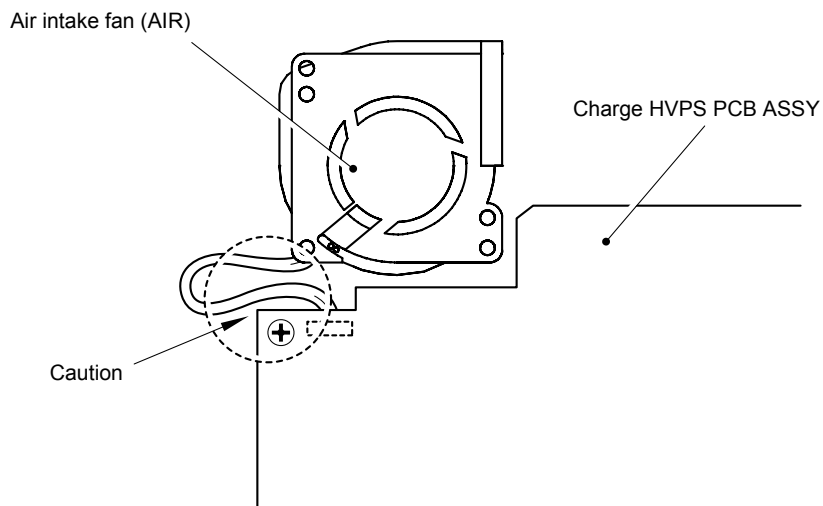

Fig. 3-207

8.51 Toner LED PCB ASSY

- (1) Remove the Screw pan (S/P washer) M3x16, and then remove the Toner LED PCB from the Frame unit.

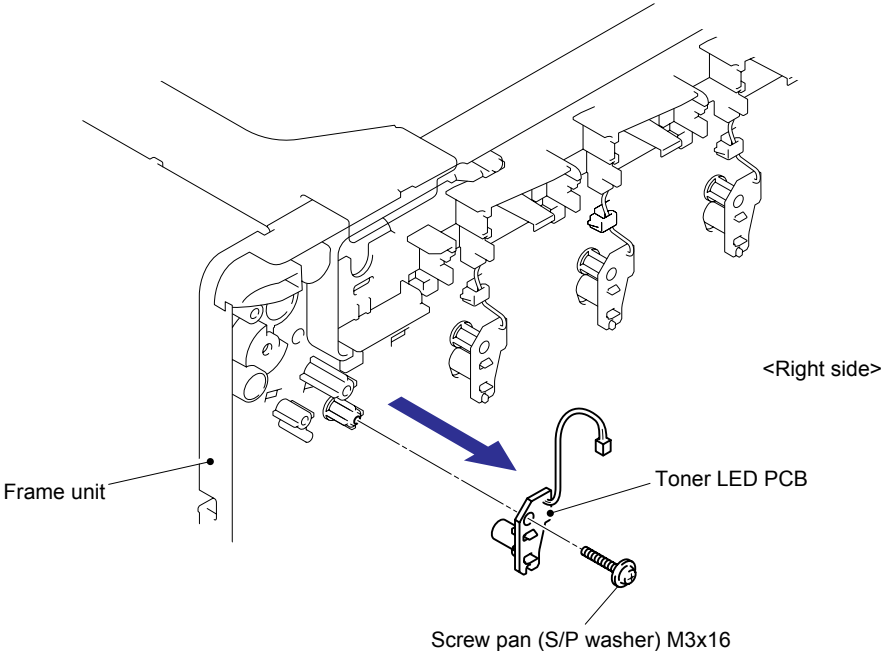

Fig. 3-208

- (2) Release the two Hooks to remove the LED holder from the Toner LED PCB.
- (3) Remove the other three Toner LED PCBs in the same way.

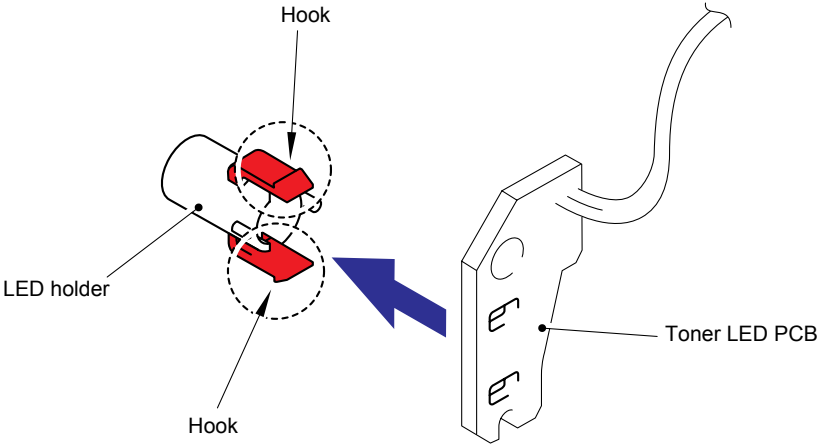

Fig. 3-209

8.52 Fuser Unit Fan (FU)

- (1) Remove the Fuser unit fan (FU) from the Frame unit.

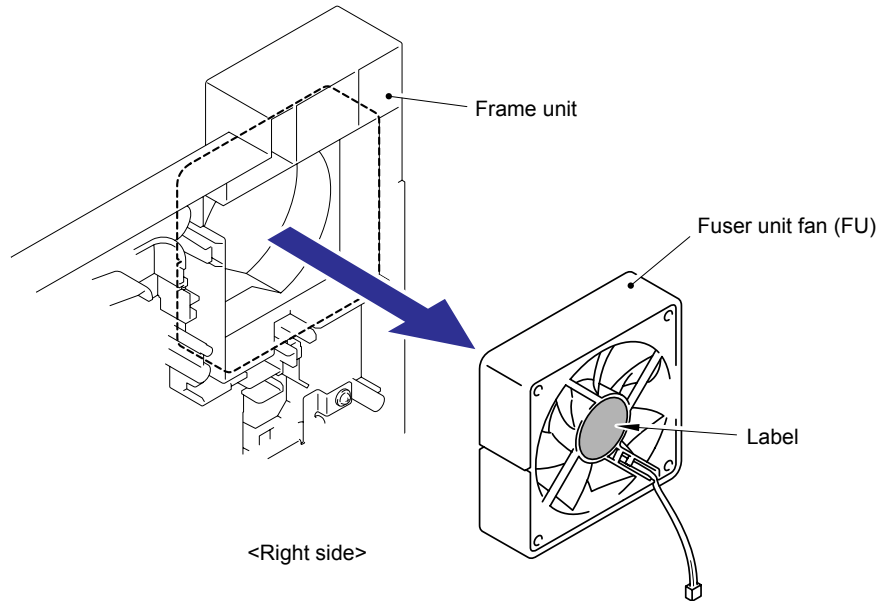

Fig. 3-210

Assembling Note:

When assembling the Fuser unit fan (FU), place it so that the attached Label faces outwards.

8.53 LVPS Fan (PS)

- (1) Remove the LVPS fan (PS) from the Frame unit.

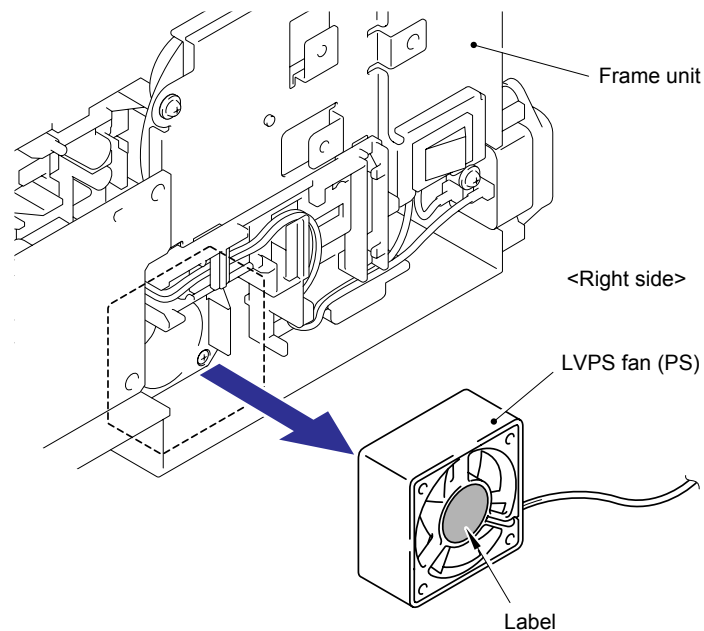

Fig. 3-211

Assembling Note:

When assembling the LVPS fan (PS), place it so that the attached Label faces outwards.

8.54 Air Intake Fan (AIR)

(1) Remove the Air intake fan (AIR) from the Frame unit.

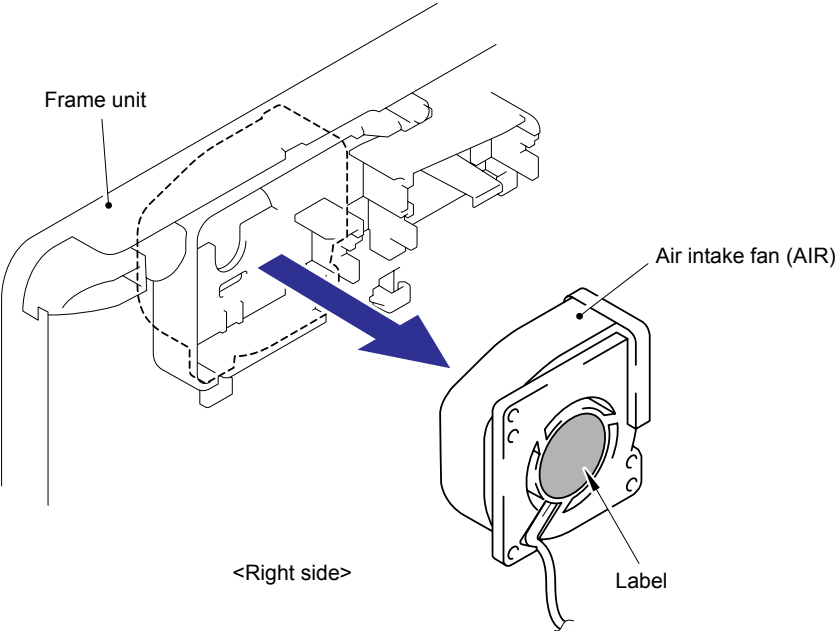

Fig. 3-212

Assembling Note:

When assembling the Air intake fan (AIR), place it so that the attached Label faces outwards.

8.55 PS PCB Unit

- (1) Remove the LVPS insulation sheet and LVPS V0 insulation sheet from the PS PCB unit.

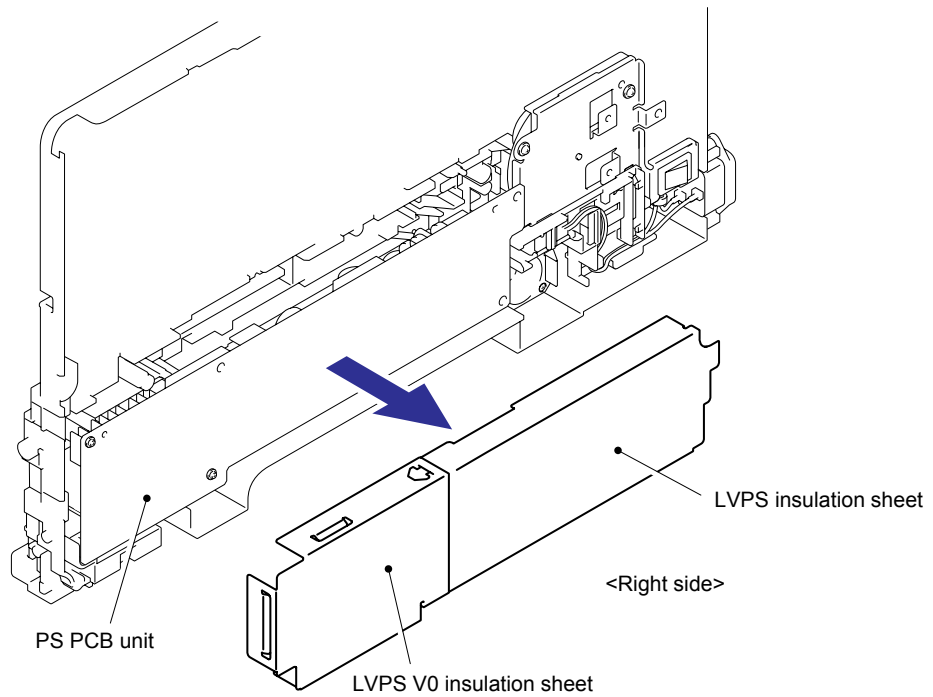

Fig. 3-213

- (2) Remove the Power supply switch from the Belt gear plate ASSY by pushing the Hooks inwards.

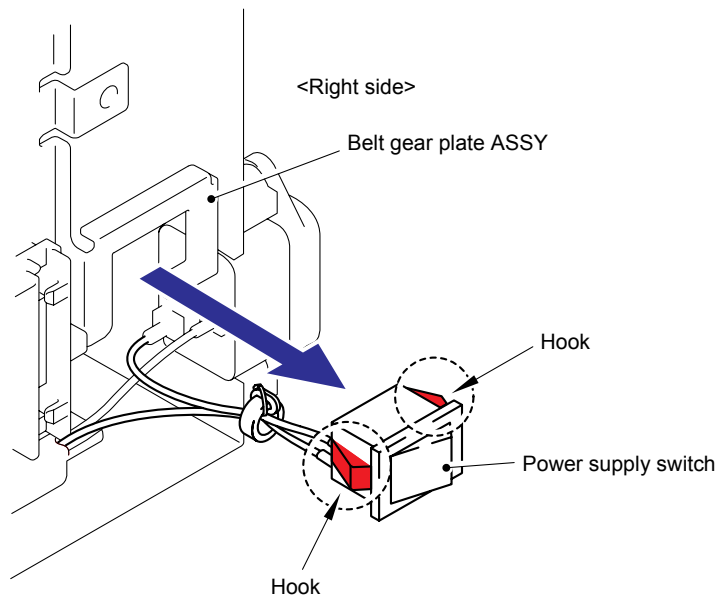

Fig. 3-214

- (3) Remove the Screw pan (S/P washer) M4x8, and then remove the Ground terminal.
- (4) Remove the two Taptite, flat B M3x10, and then remove the Power inlet socket from the Frame unit.

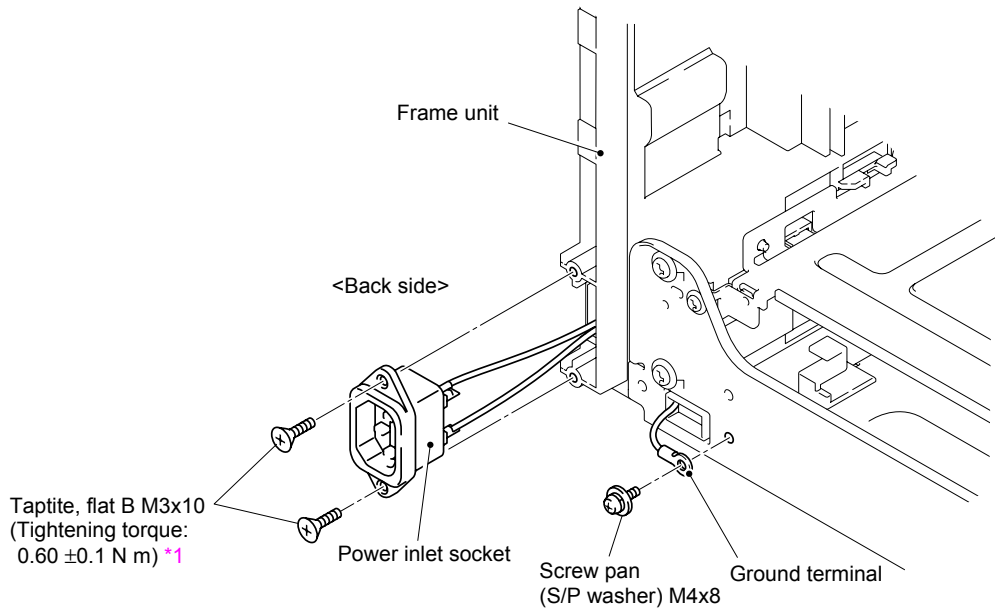

Fig. 3-215

- (5) Remove the three bind B M4x12 Taptite screws, and then release the Hook to remove the PS PCB unit from the Frame unit.

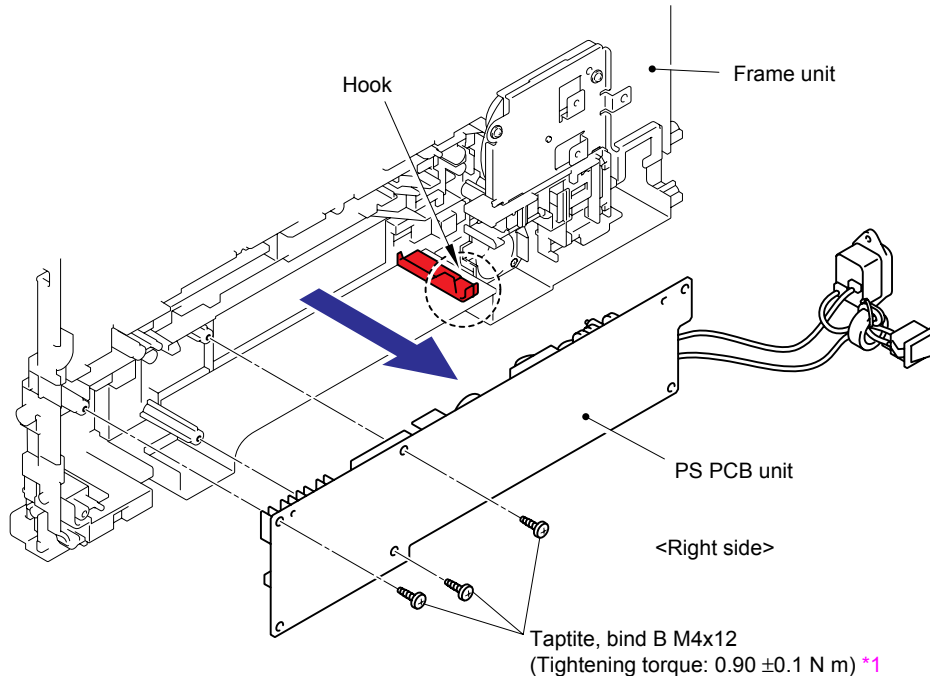

Fig. 3-216

***1 Tightening Note:**

When tightening the screw, slowly turn it counterclockwise (in the direction to loosen the screw) with your hand until you feel that the screw is a little dropped in the hole. Then, slightly turn it clockwise (in the direction to tighten the screw) with your hand and tighten it according to the specified torque with a screwdriver.

(6) Disconnect the four Connectors (CN2, CN101, CN102, CN103) from the PS PCB unit.

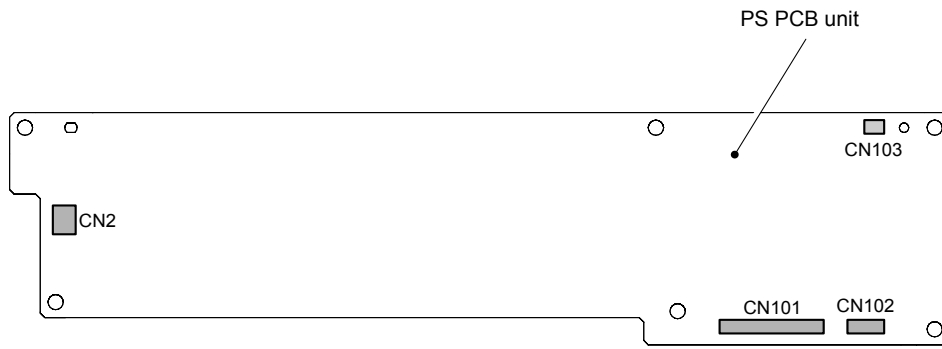

Fig. 3-217

Assembling Note:

- Assemble the LVPS insulation sheet so that the section "A" is in the position as shown in the figure below.

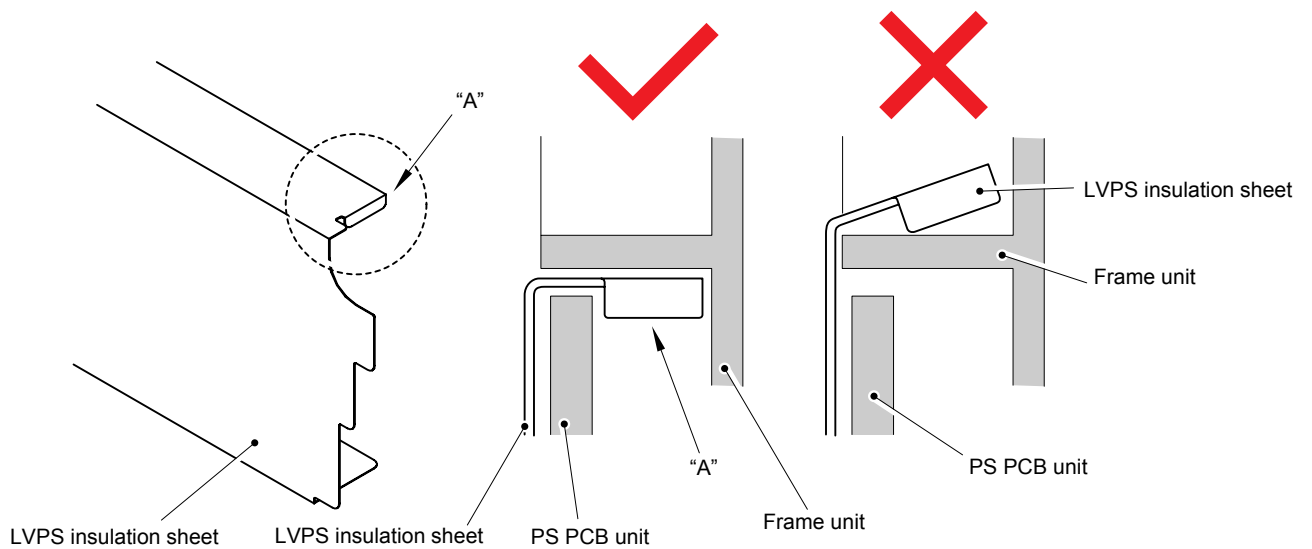

Fig. 3-218

Assembling Note:

- Assemble the Power supply switch so that the ON/OFF mark on the Power supply switch is aligned with the ON/OFF mark imprinted on the Belt gear plate ASSY.

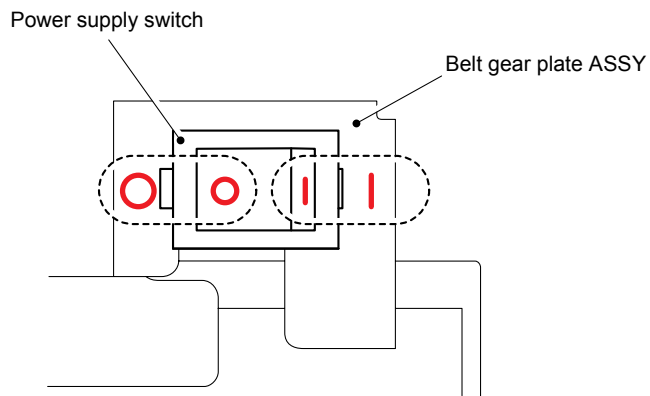

Fig. 3-219

- When assembling the PS PCB unit, align it with the two Bosses on the Frame unit.

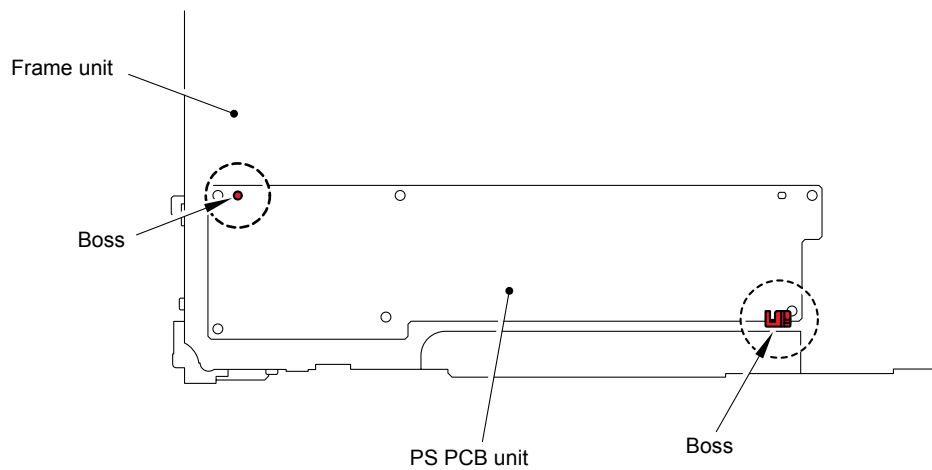

Fig. 3-220

8.56 Belt Unit Drive Motor ASSY

- (1) Release the three Hooks to remove the Harness holder 16AWG from the Belt gear plate ASSY.

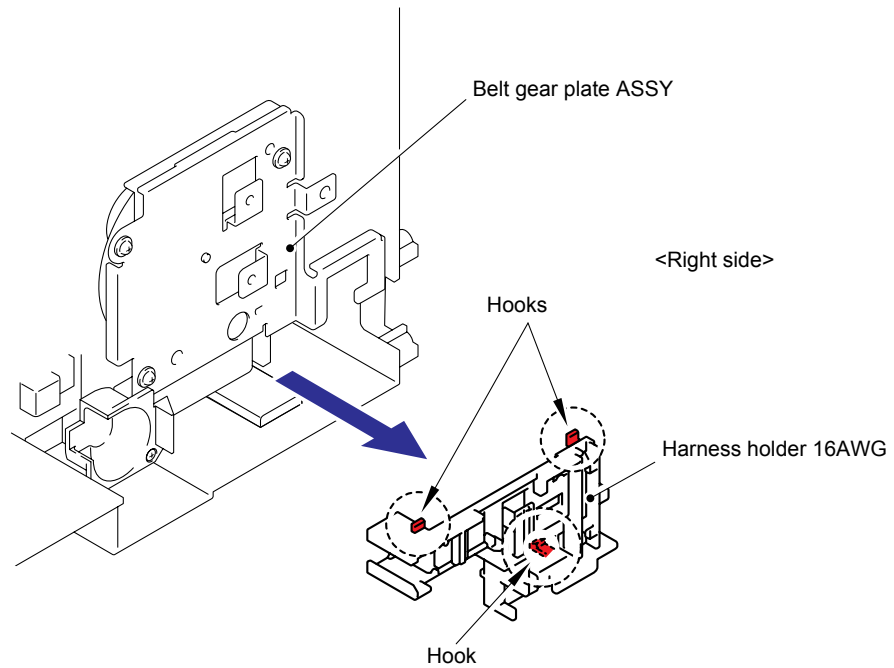

Fig. 3-221

- (2) Remove the three cup B M4x12 Taptite screws and Screw, cup M3x6, and then remove the Belt gear plate ASSY from the Frame unit.

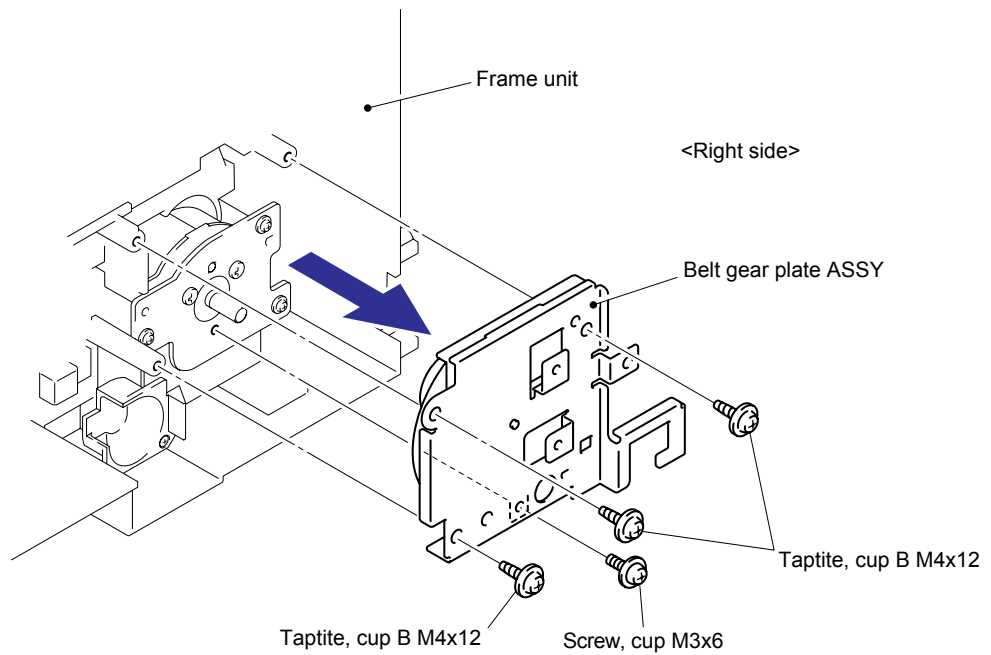

Fig. 3-222

- (3) Remove the bind B M3x10 Taptite screw, and then remove the LV fan duct from the Frame unit.

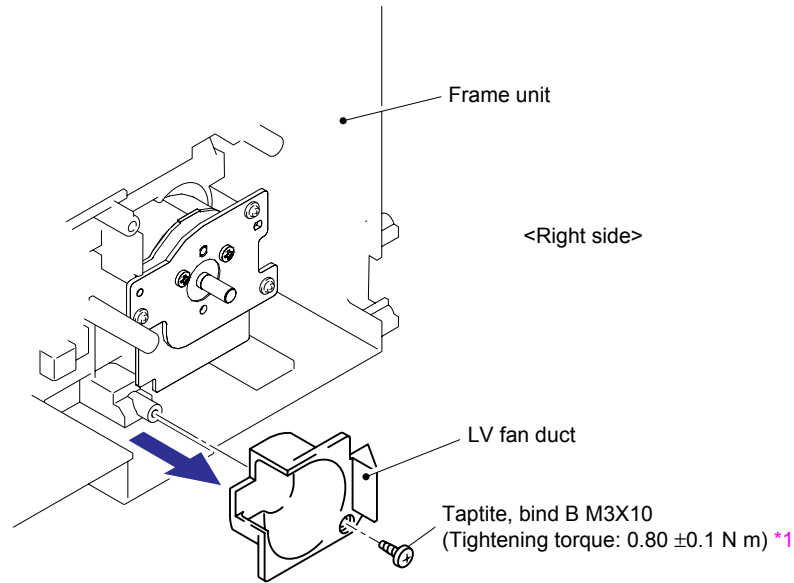

Fig. 3-223

- (4) Remove the three cup B M4x12 Taptite screws, and then remove the Belt unit drive motor ASSY from the Frame unit.
(5) Disconnect the Connector from the Belt unit drive motor ASSY.

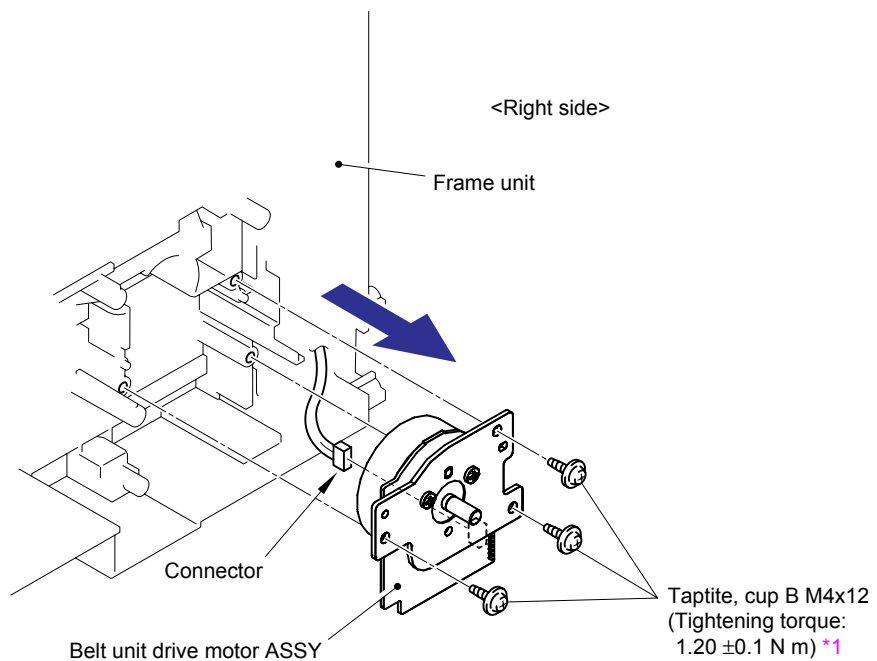

Fig. 3-224

***1 Tightening Note:**

When tightening the screw, slowly turn it counterclockwise (in the direction to loosen the screw) with your hand until you feel that the screw is a little dropped in the hole. Then, slightly turn it clockwise (in the direction to tighten the screw) with your hand and tighten it according to the specified torque with a screwdriver.

- (6) Remove the two Screws bind M3x5, and then remove the Belt unit drive motor from the Motor plate P.

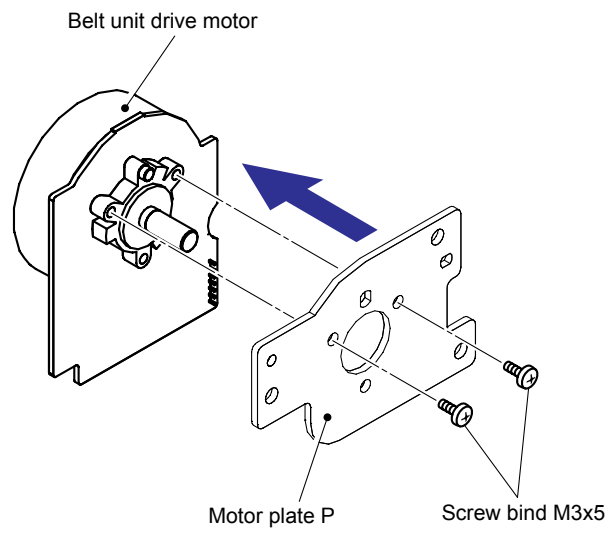

Fig. 3-225

9. DISASSEMBLY PROCEDURE (LT-100CL) (MFC-9440CN/ 9450CDN ONLY)

9.1 LT Paper Tray

- (1) Pull out the LT paper tray, and remove the paper from the LT paper tray.

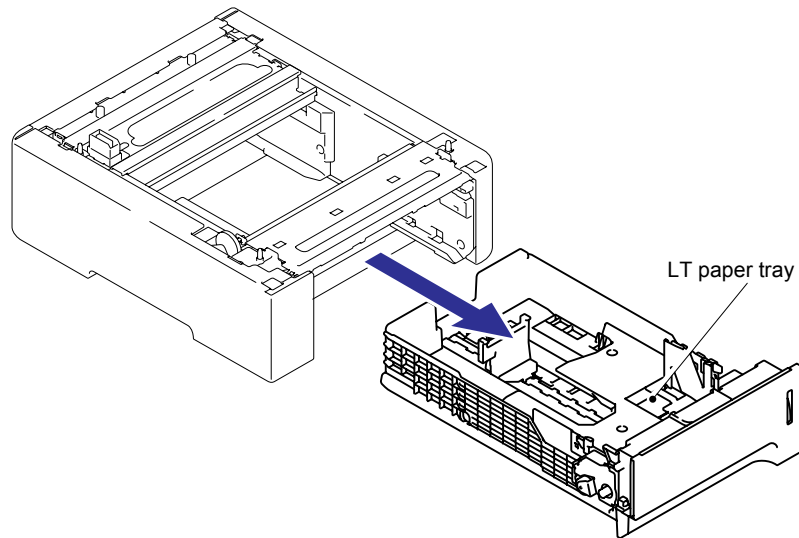

Fig. 3-226

- (2) Release the two Hooks of the LT separation pad ASSY, and then lift up the LT separation pad ASSY.

Note:

Be careful not to loose the LT separation pad spring.

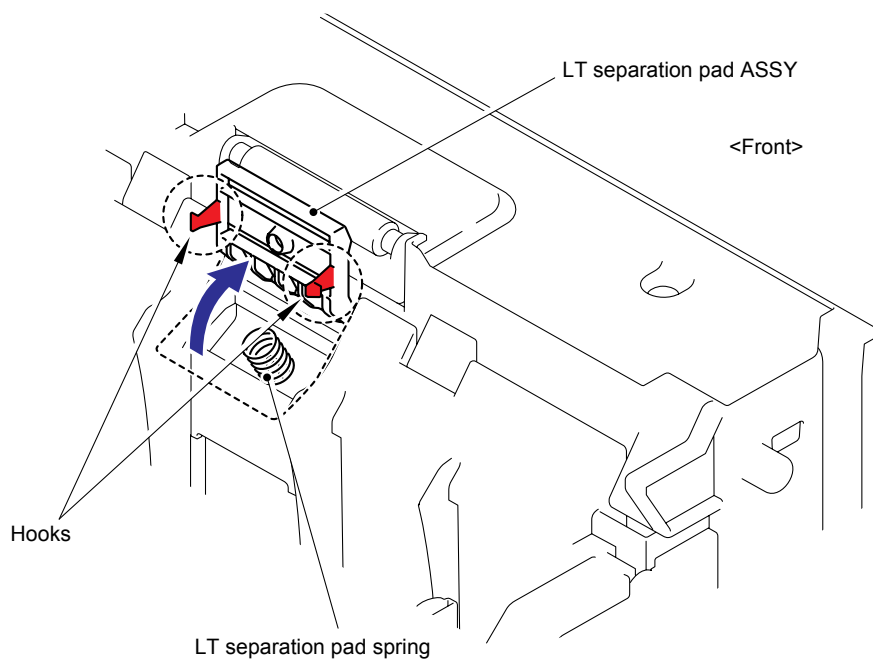

Fig. 3-227

- (3) Push both sides of the LT separation pad ASSY inwards to release the Pins and remove the LT separation pad ASSY from the LT paper tray.

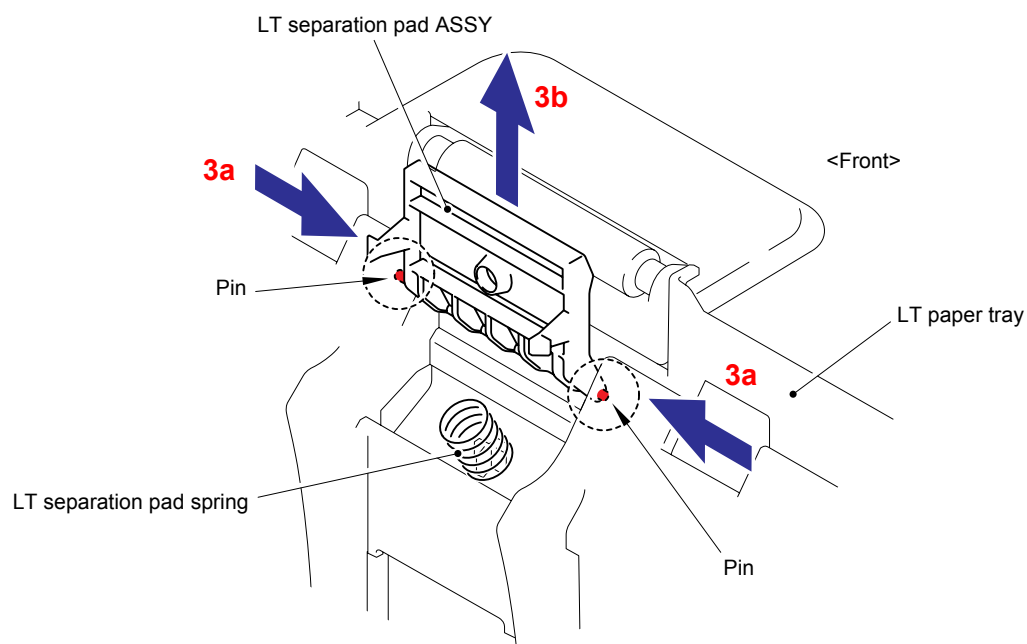

Fig. 3-228

- (4) Remove the LT separation pad spring from the LT paper tray.

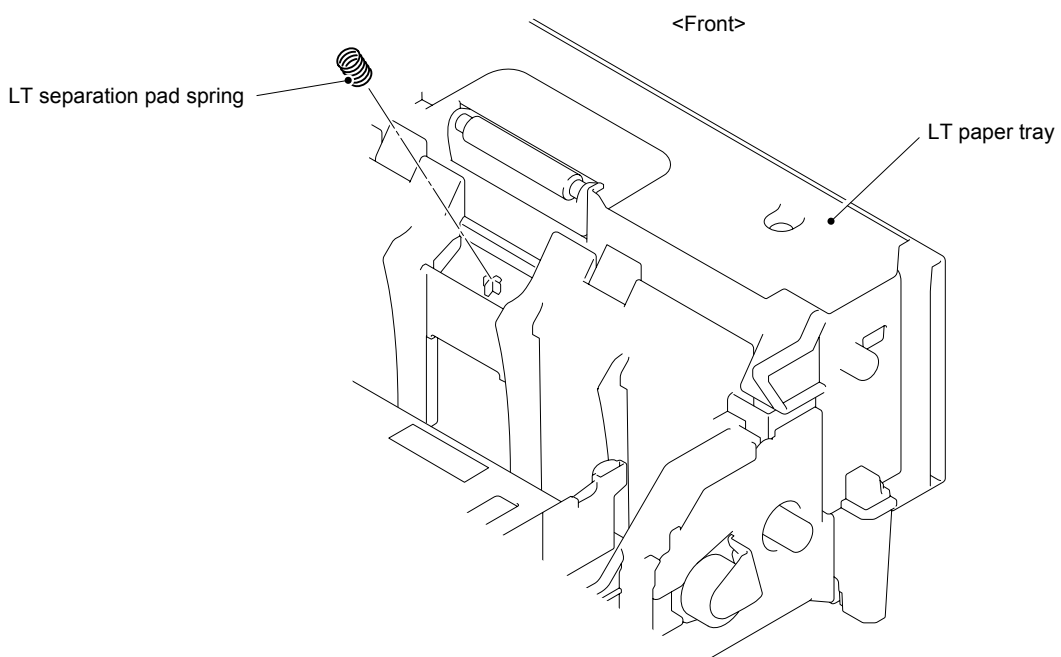

Fig. 3-229

- (5) Remove the two bind B M4x10 Taptite screws from the Pinch roller holder cover LT.
- (6) Release the four Hooks to remove the Pinch roller holder cover LT from the LT paper tray.

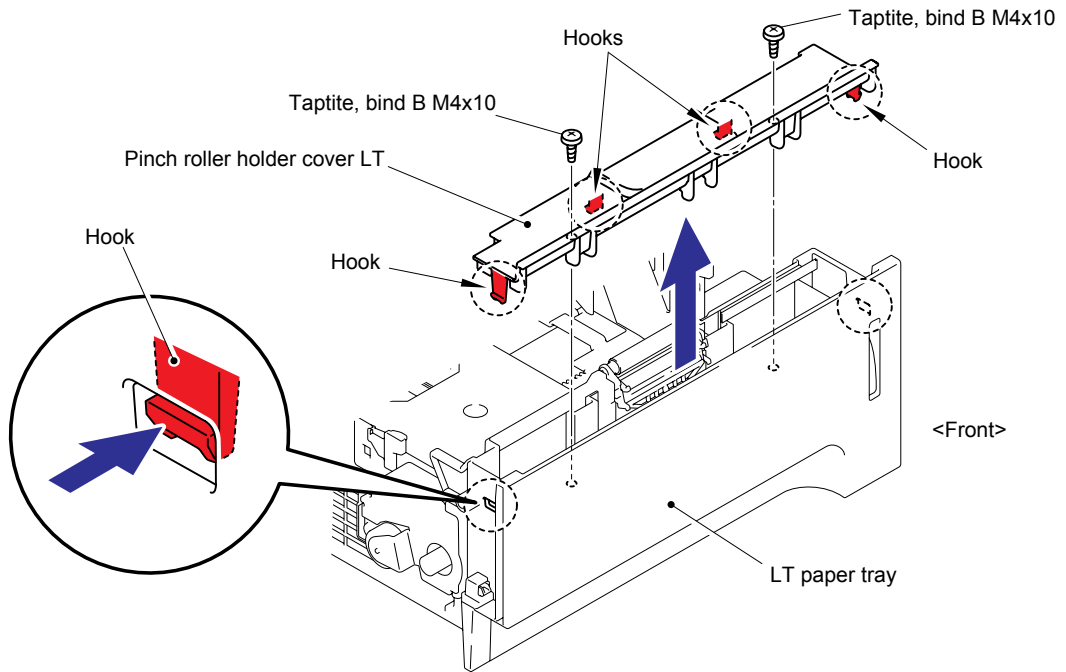

Fig. 3-230

- (7) Remove the Pinch roller holder spring from the Rib of the LT paper tray.

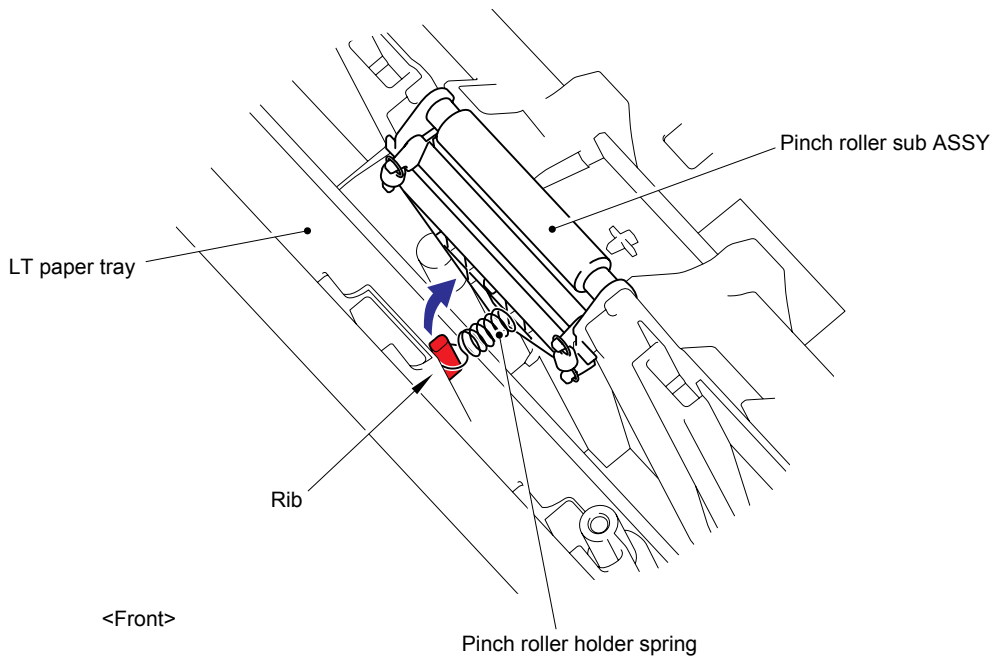

Fig. 3-231

(8) Release the Pin to remove the Pinch roller sub ASSY from the LT paper tray.

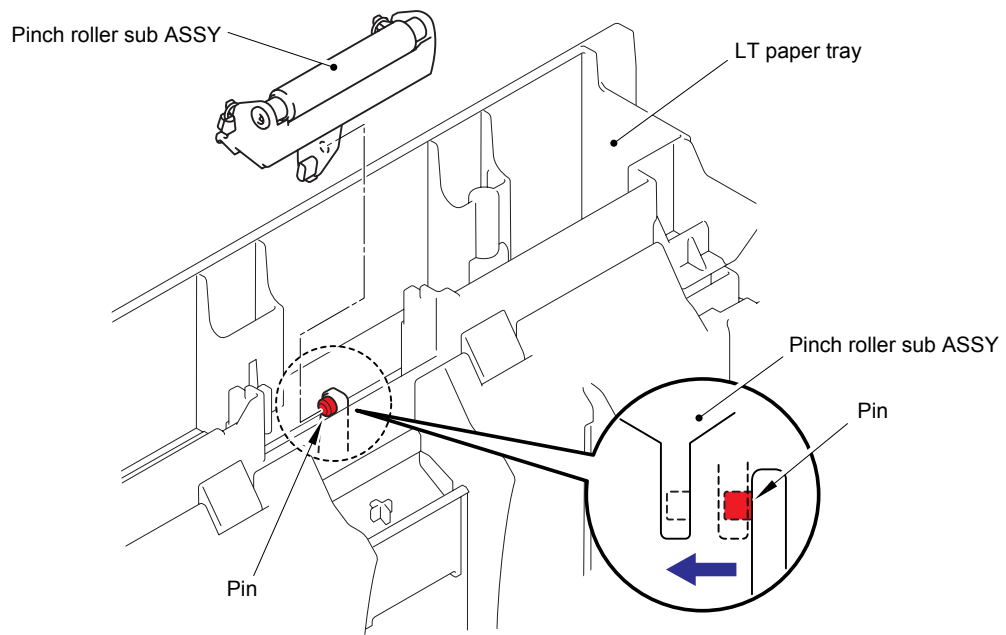

Fig. 3-232

9.2 LT Cover Rear

(1) Remove the four Shoulder screws from the LT cover rear.

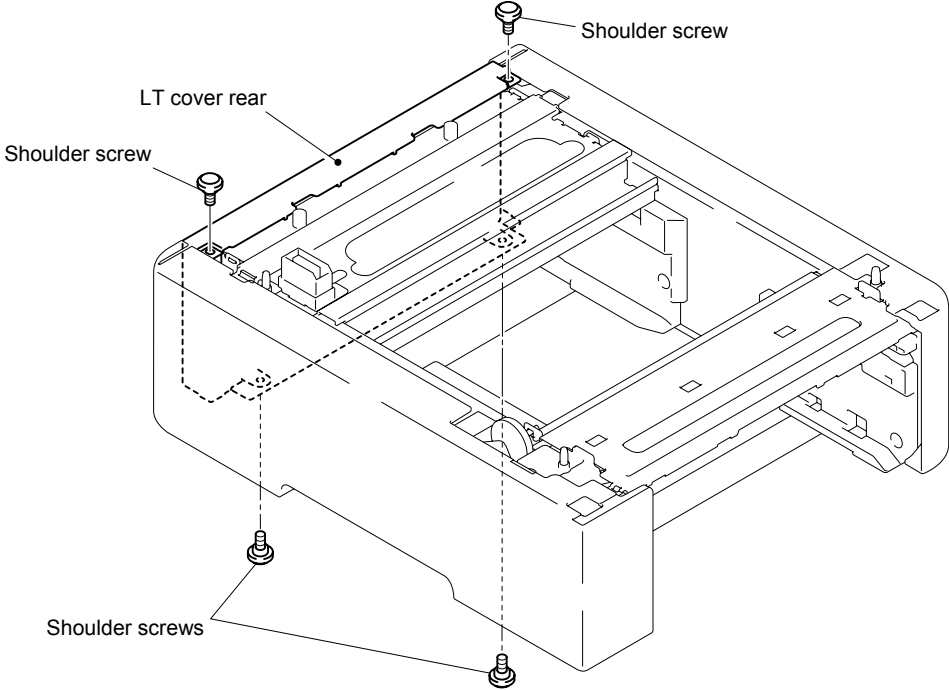

Fig. 3-233

(2) Release the two Pins on the bottom to remove the LT cover rear.

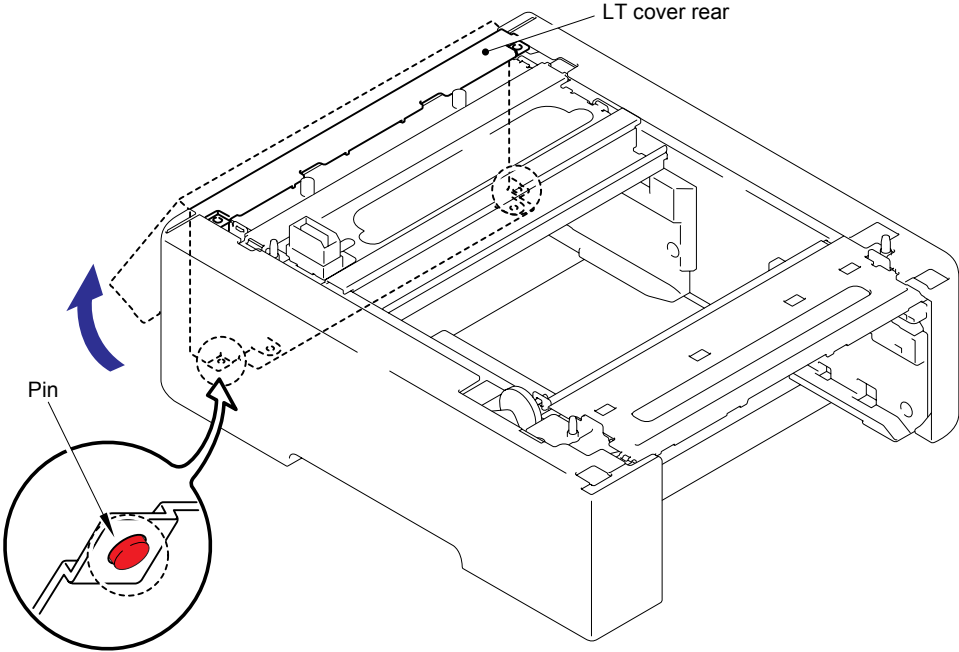

Fig. 3-234

9.3 LT Cover Left

(1) Remove the three Shoulder screws from the LT cover left.

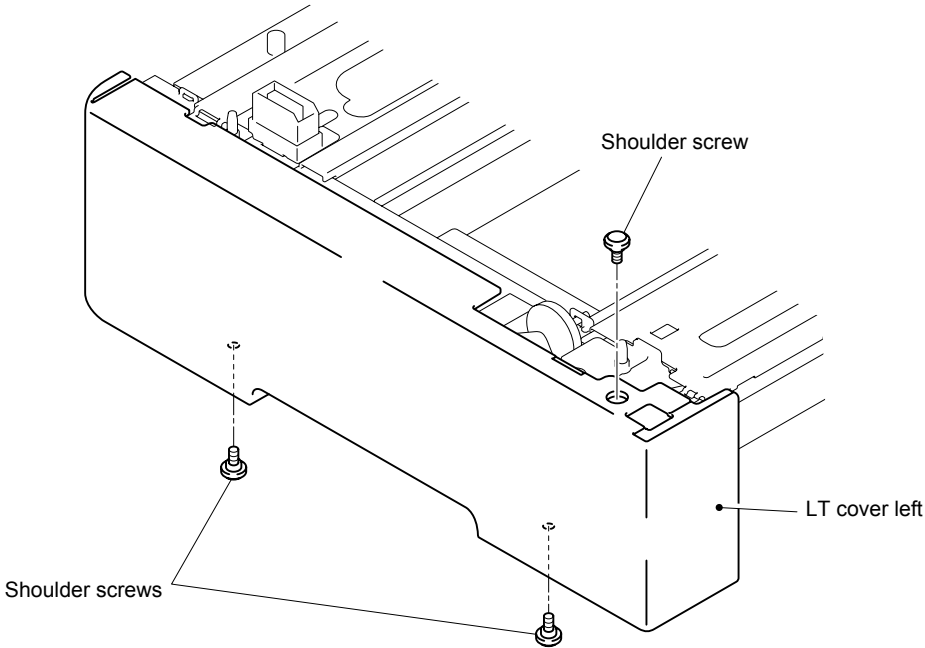

Fig. 3-235

(2) Release the two Hooks on the upper side and the two Hooks on the Back to remove the LT cover left.

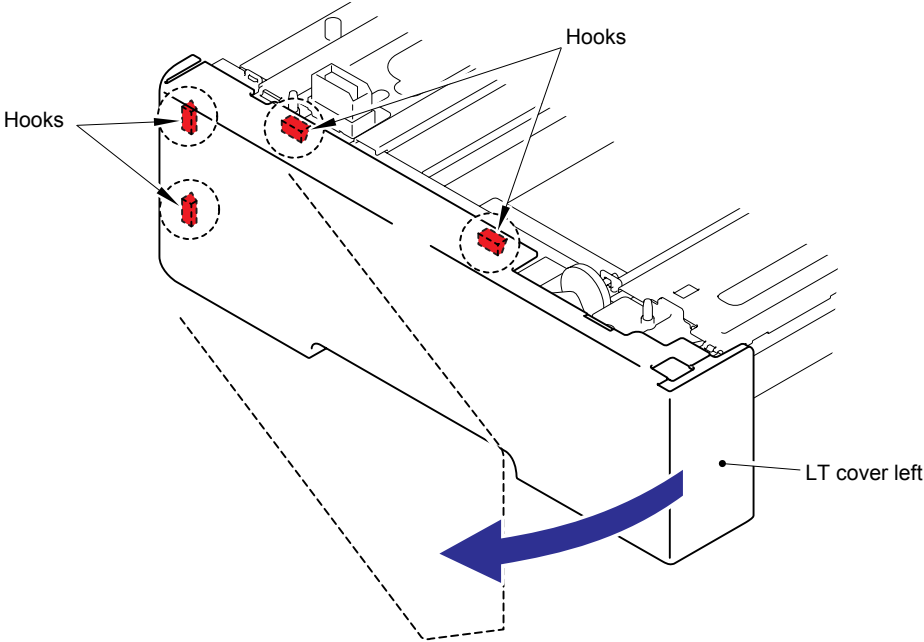

Fig. 3-236

9.4 LT Cover Right

(1) Remove the three Shoulder screws from the LT cover right.

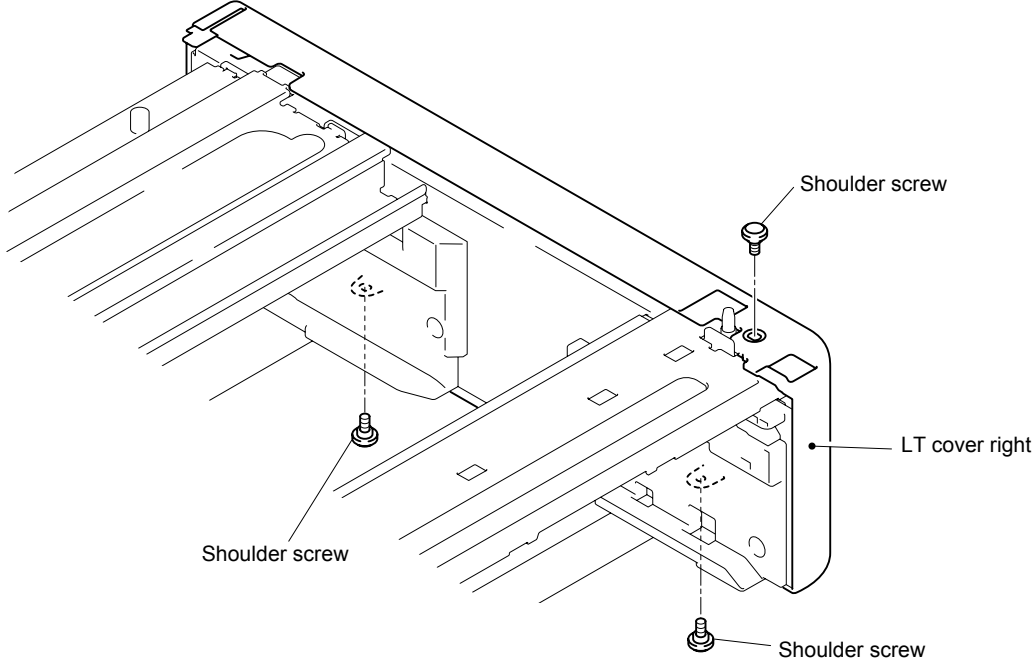

Fig. 3-237

(2) Release the two Hooks on the upper side and the two Hooks on the Back to remove the LT cover right.

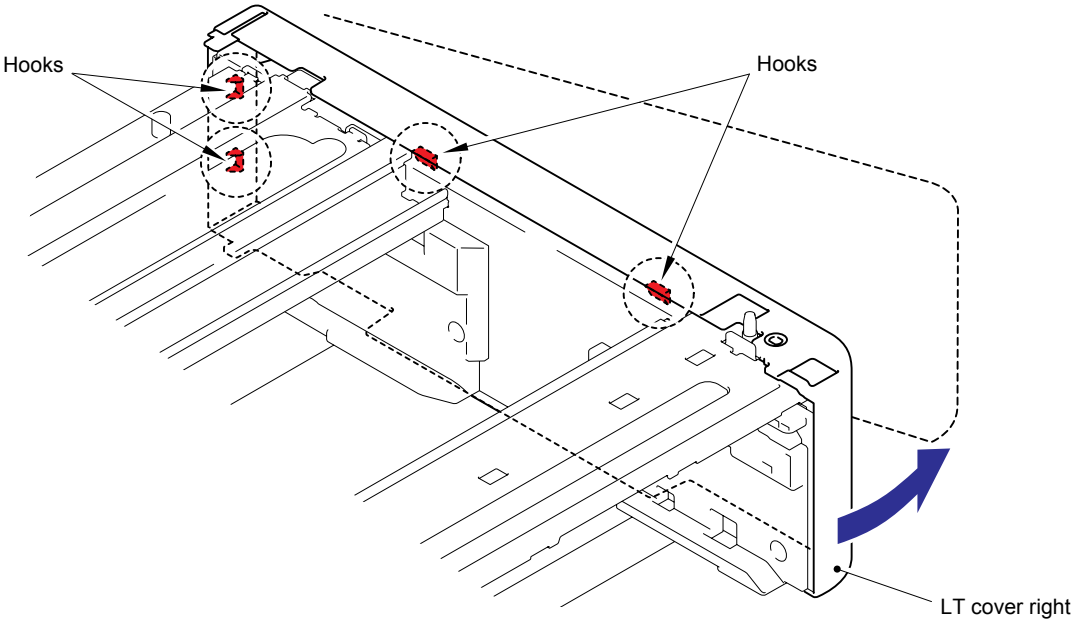

Fig. 3-238

9.5 LT Relay PCB ASSY

(1) Disconnect the all connectors from the LT relay PCB ASSY.

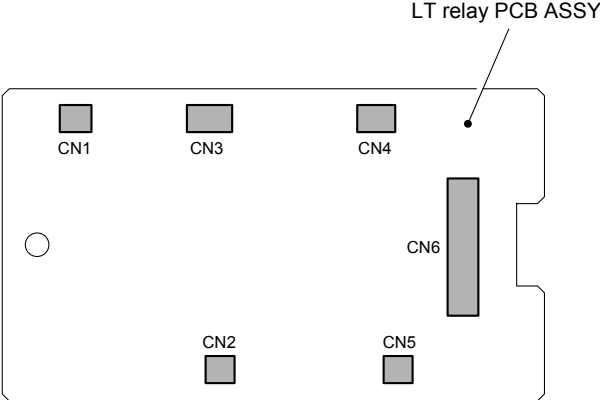

Fig. 3-239

(2) Remove the cup S M3x6 Taptite screw, and then remove the LT relay PCB ASSY.

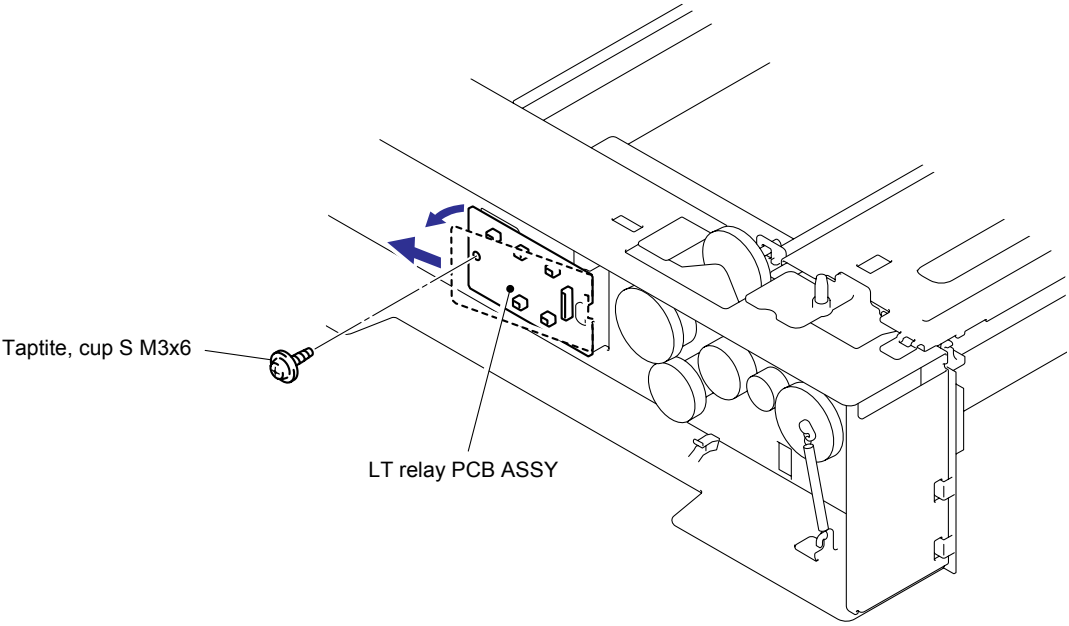

Fig. 3-240

9.6 LT Solenoid ASSY

(1) Remove the cup S M3x6 Taptite screw, and then remove the Solenoid holder ASSY.

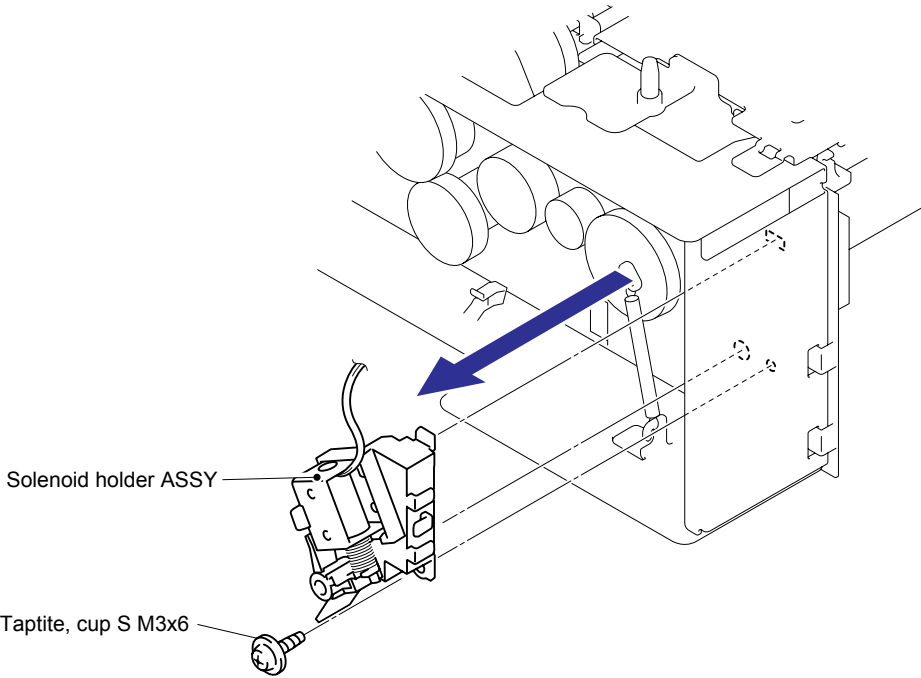

Fig. 3-241

(2) Remove the Screw flanged M3X3.5, and then remove the LT solenoid ASSY and Solenoid spring MP from the LT solenoid holder.

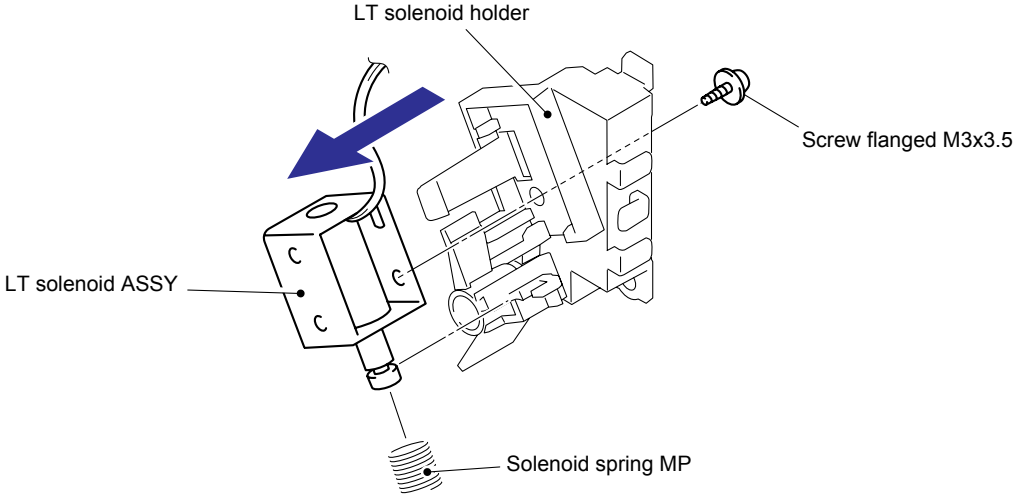

Fig. 3-242

9.7 Collar 6

- (1) Remove the two Collars 6 from the Fittings shaft.

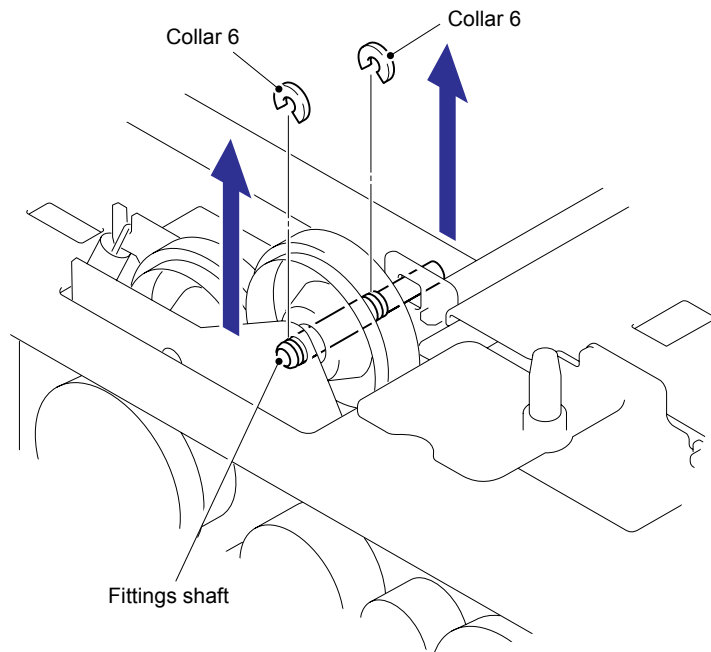

Fig. 3-243

9.8 Cassette Switch ASSY

- (1) Remove the three cup S M3x6 Taptite screws and release the Hook. Then, remove the LT tray guide left rear ASSY.

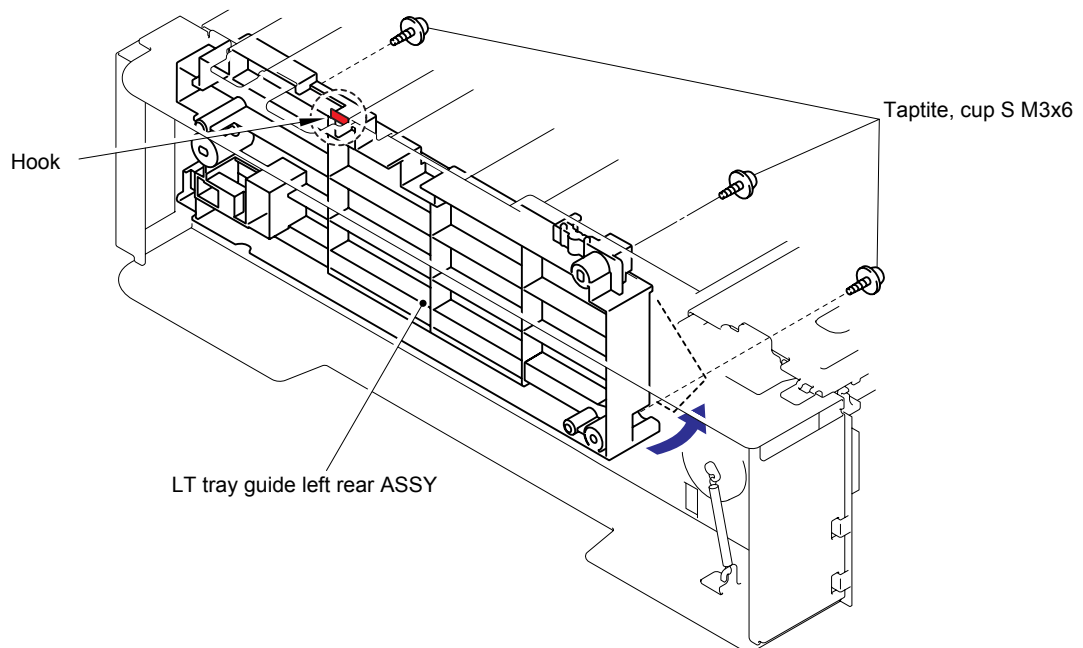

Fig. 3-244

(2) Release the Hook to remove the Cassette actuator and Cassette actuator spring.

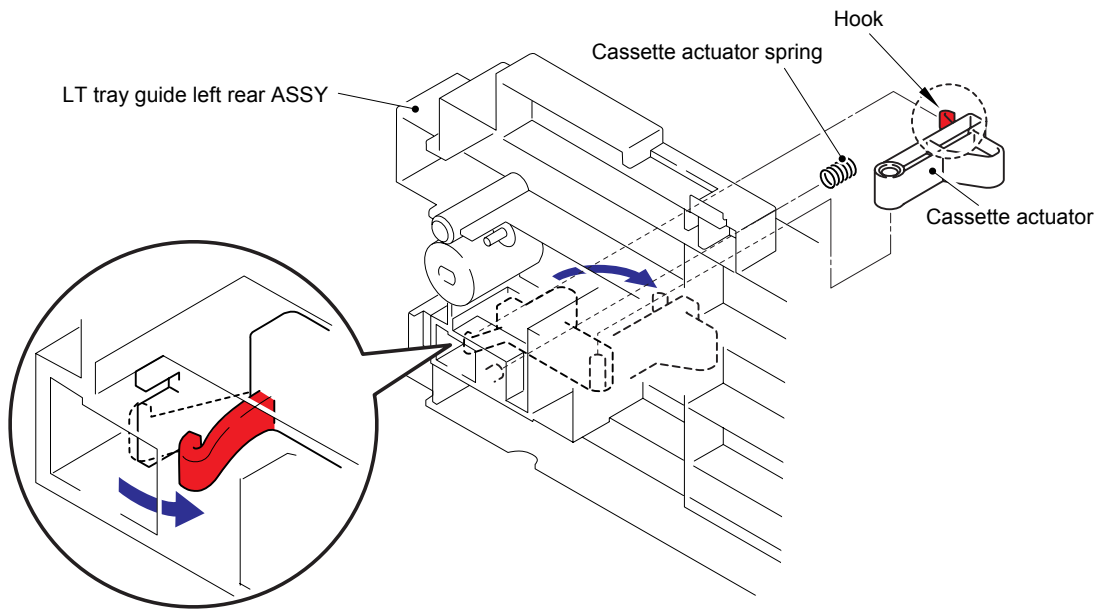

Fig. 3-245

(3) Release the two Hooks to remove the Cassette switch ASSY.

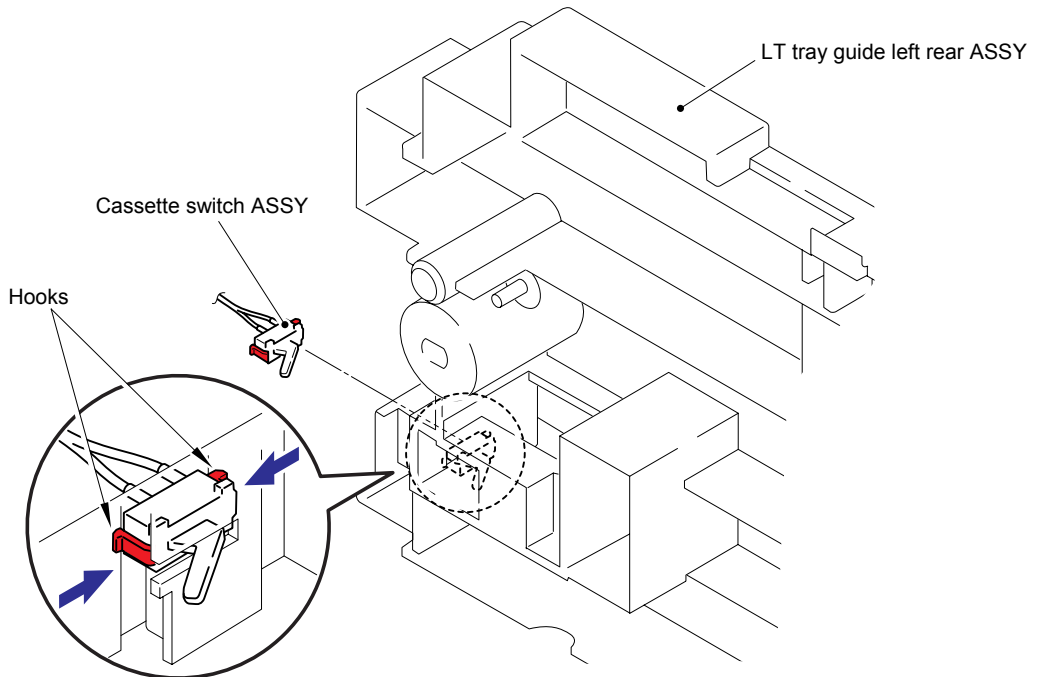

Fig. 3-246

9.9 LT Paper Feed Frame Unit

- (1) Remove the four cup S M3x6 Taptite screws, and then remove the LT front cover and LT beam F from the LT frame unit.

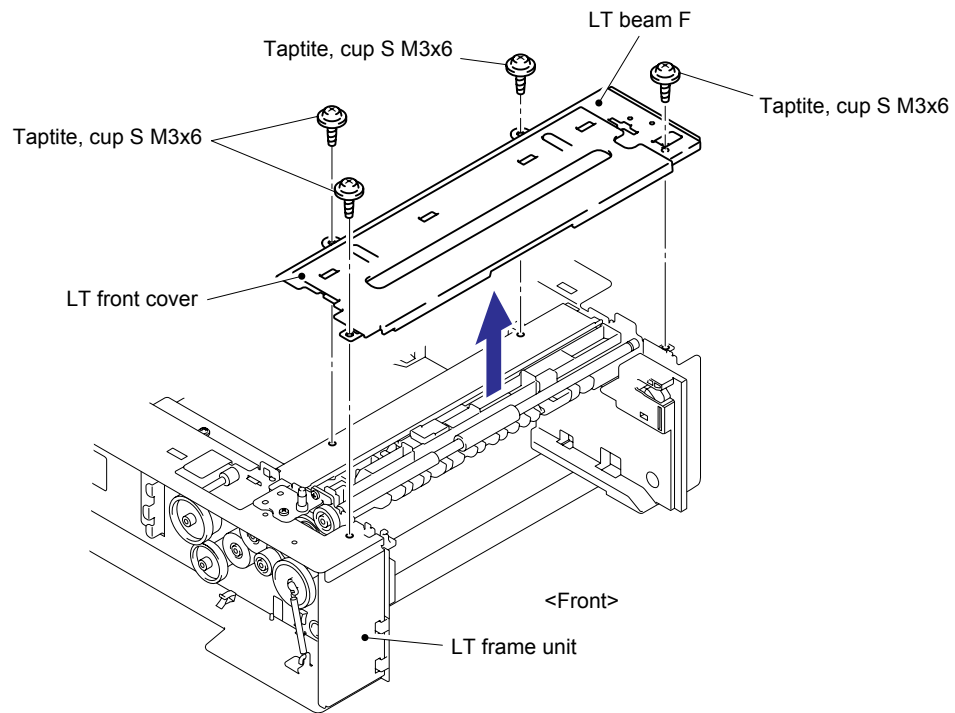

Fig. 3-247

- (2) Remove the Retaining ring E4 from the F roller shaft LT and remove the Gear 24 LT and FR bush.

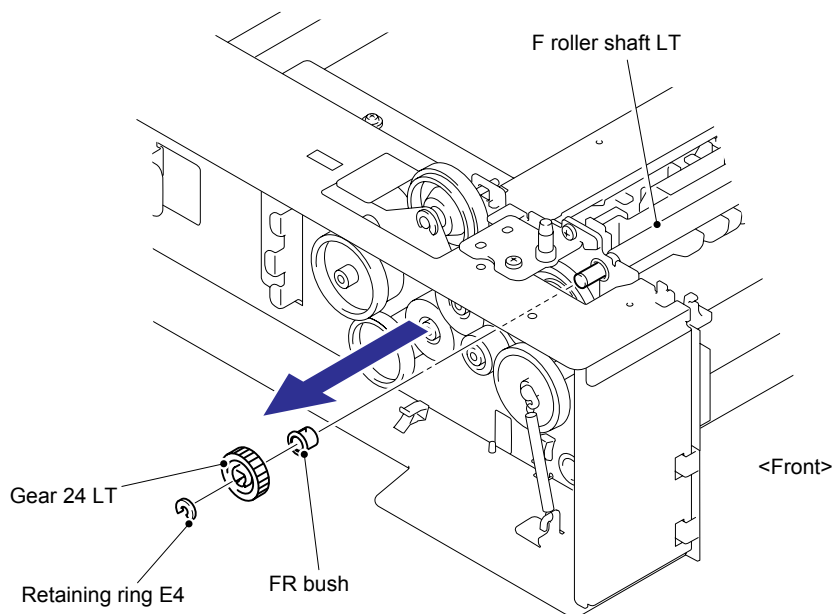

Fig. 3-248

- (3) Remove the Retaining ring E3 from the F roller shaft LT and remove the FR bush TR.

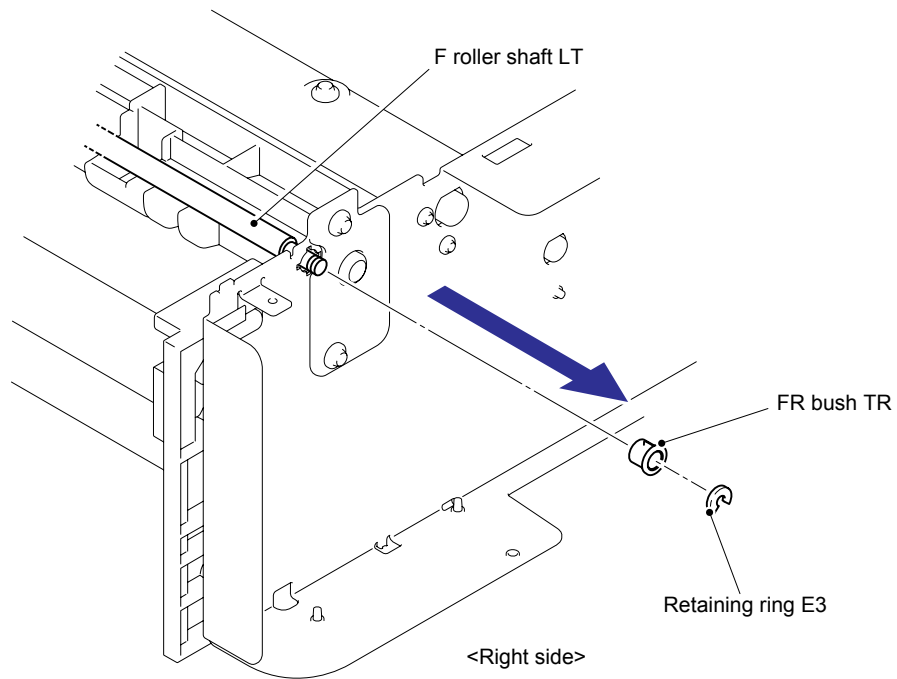

Fig. 3-249

- (4) Remove the Lift spring from the Hook of the Lift lever A.
- (5) Remove the F roller shaft LT from the LT frame unit by pushing right (5a), pull left end forward (5b) and remove leftwards (5c).

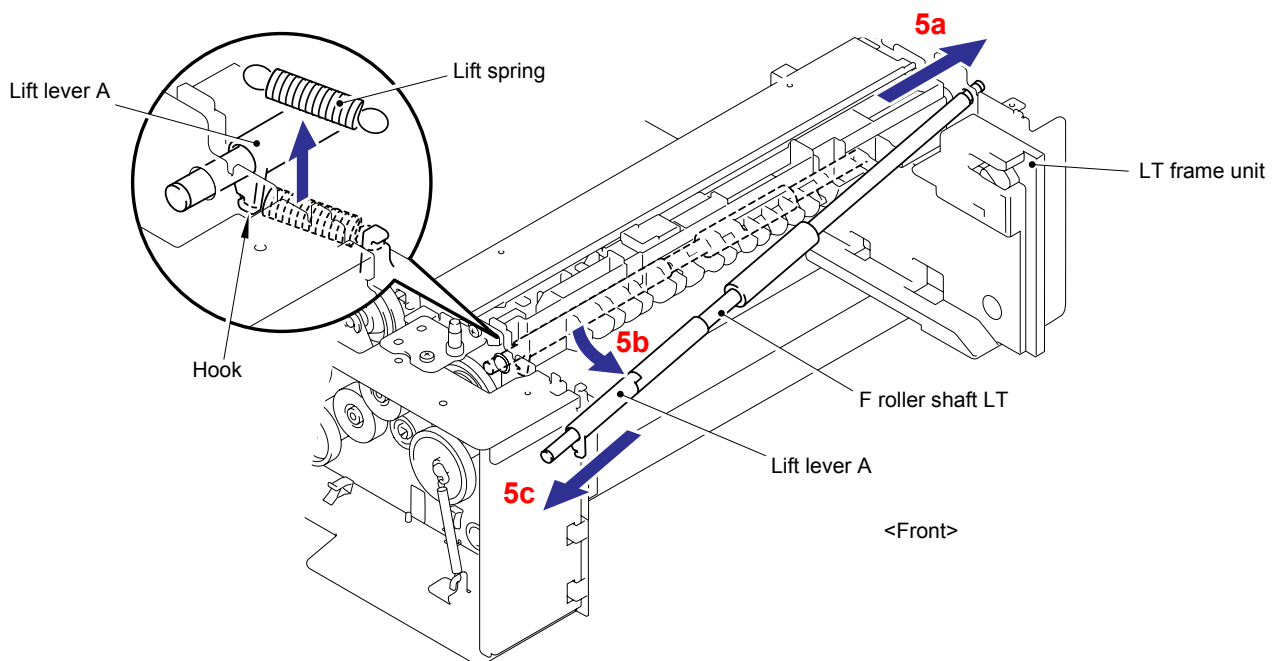

Fig. 3-250

Assembling Note:

When assembling the F roller shaft LT, place the Rib of the Paper feed frame unit between the section "A" and "B" of the Lift lever B and align the section "B" with the Lever of the Paper feed holder.

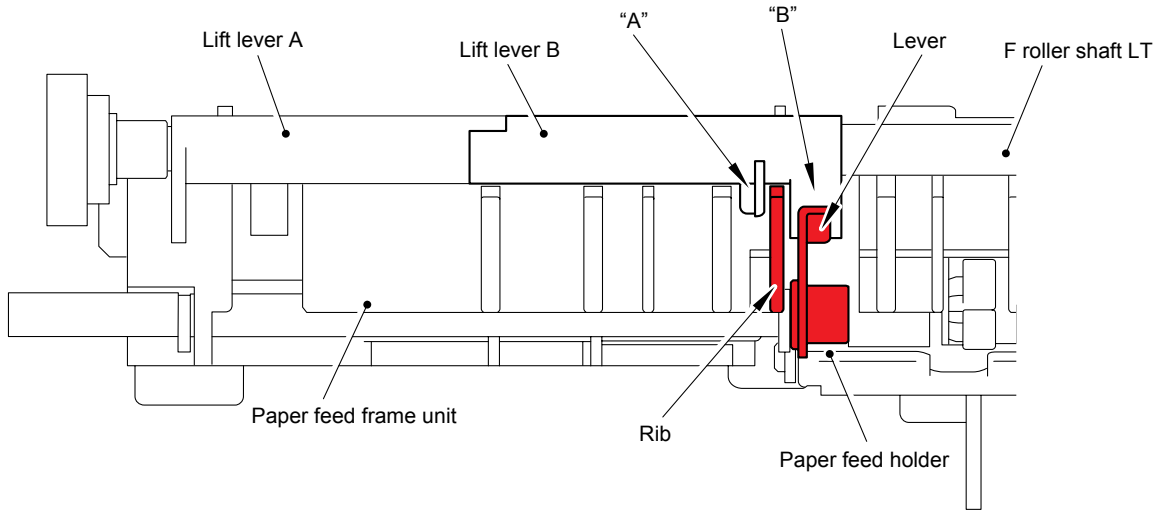

Fig. 3-251

(6) Remove the two cup S M3x6 Taptite screws from the LT frame unit.

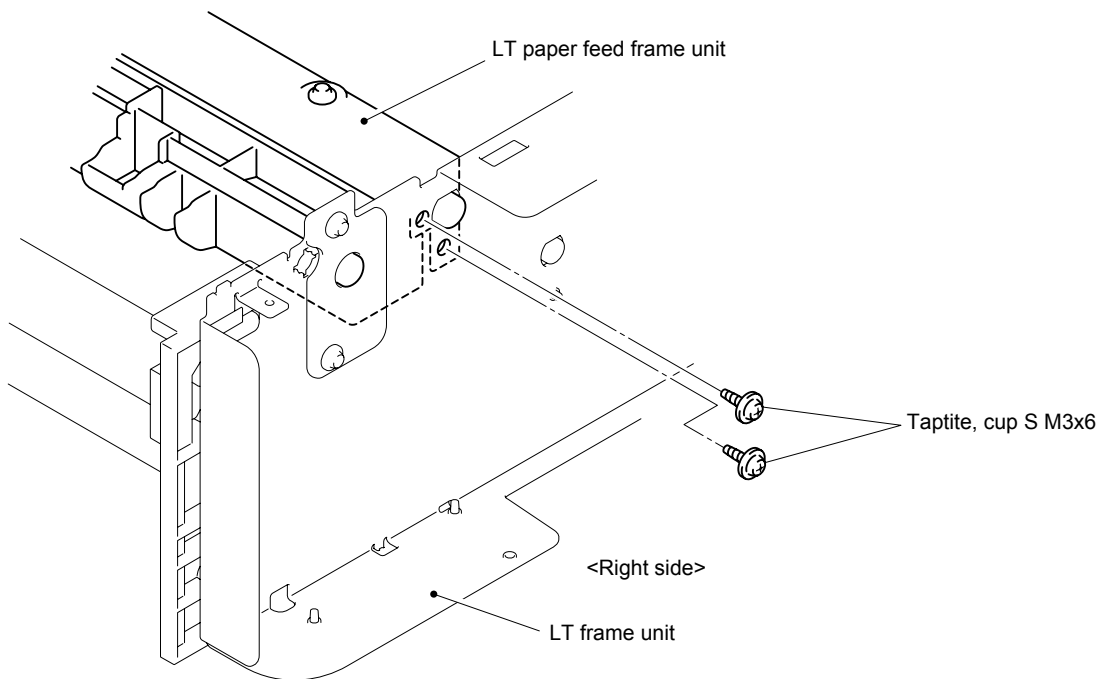

Fig. 3-252

(7) Remove the Gear 20A from the Drive unit by releasing the Hook.

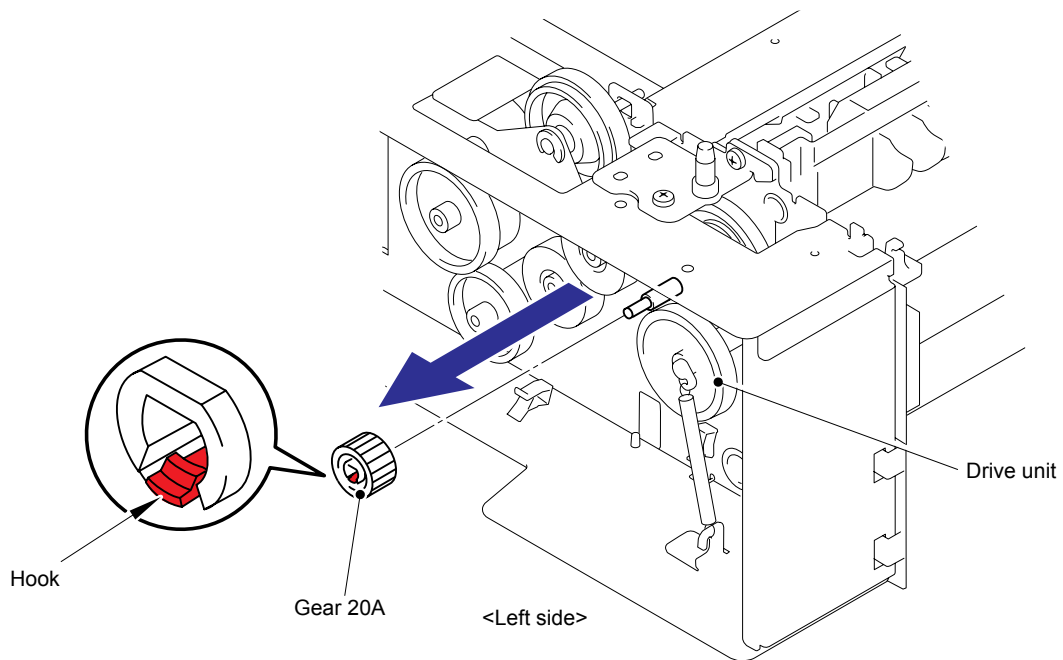

Fig. 3-253

(8) Remove the Gear 33 from the Drive unit by releasing the Hook.

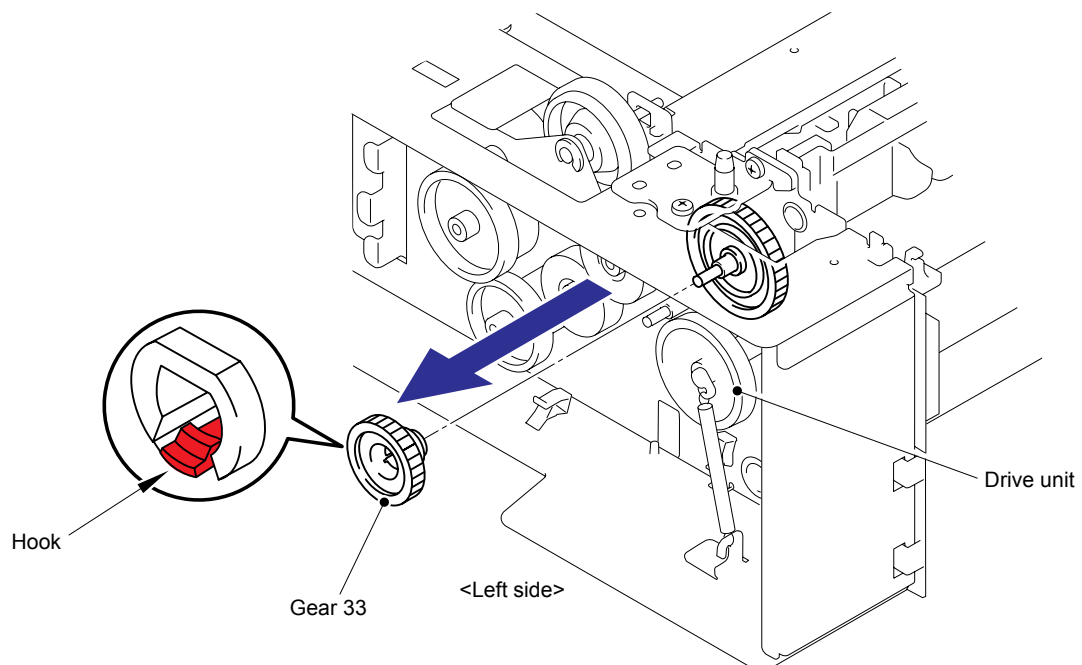

Fig. 3-254

- (9) Remove the Extension spring LT from the Spring hook and remove the Gear 46/55 from the Drive unit by releasing the Hook.

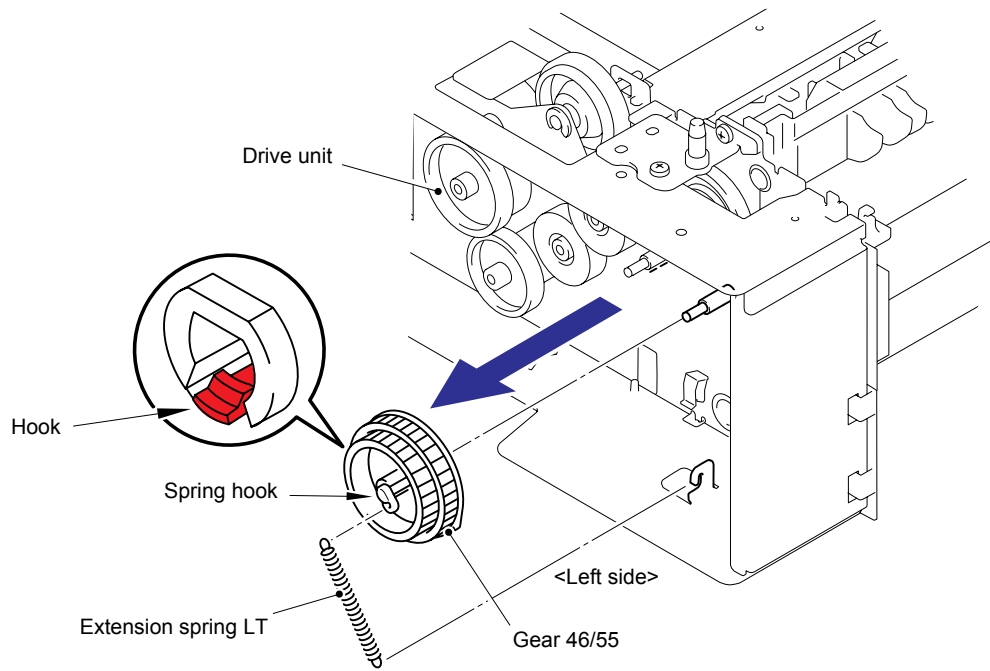

Fig. 3-255

- (10) Remove the Gear 46 LT from the Drive unit.

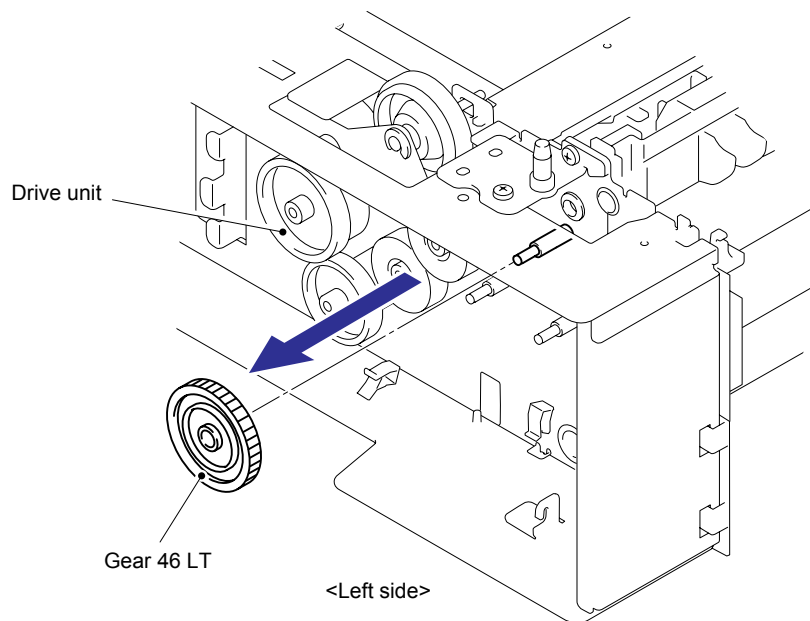

Fig. 3-256

- (11) Remove the two cup S M3x6 Taptite screws and one bind B M4x10 Taptite screw from the LT frame L unit.

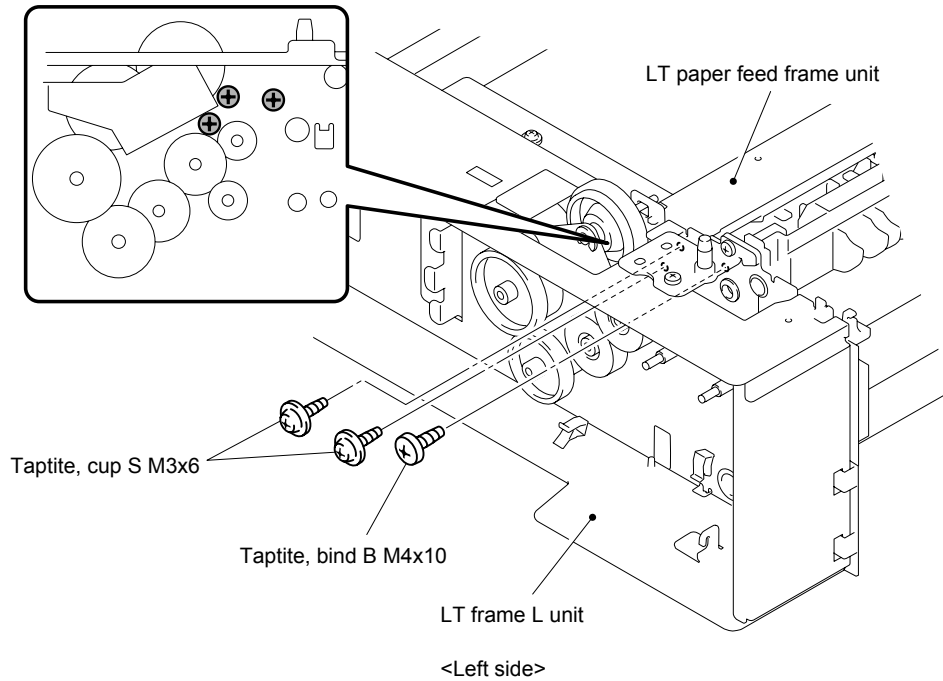

Fig. 3-257

- (12) Turn the LT frame unit upside down.

- (13) Remove the two cup S M3x6 Taptite screws from the LT frame unit.

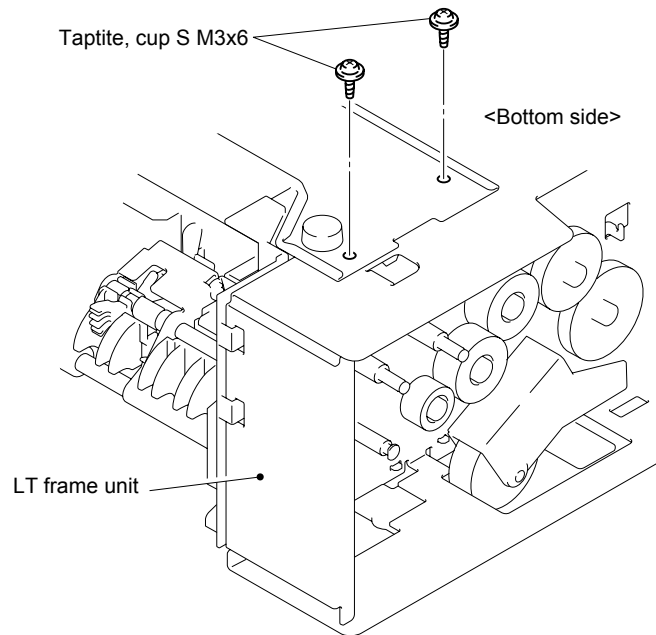

Fig. 3-258

(14) Turn the LT frame unit the correct way up.

(15) Remove the two cup S M3x6 Taptite screws from the LT beam R.

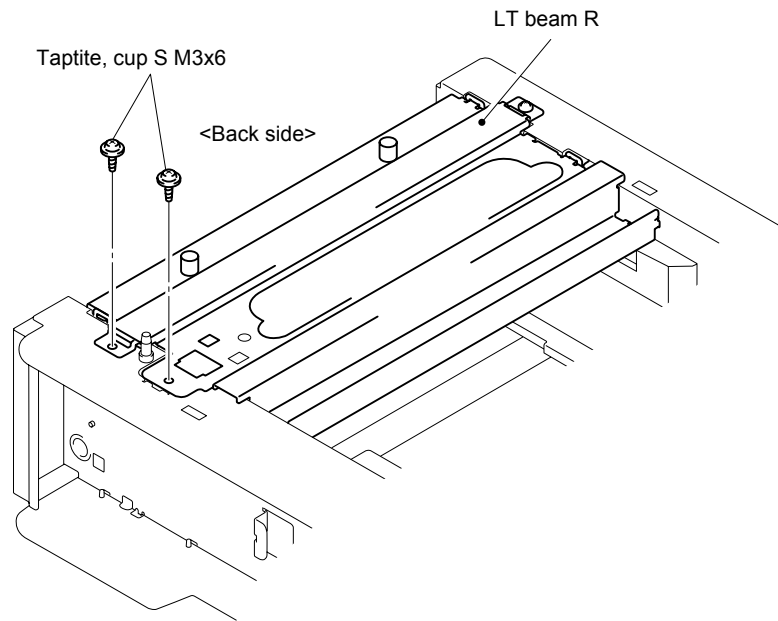

Fig. 3-259

(16) Remove the cup S M3x6 Taptite screw from the LT frame unit.

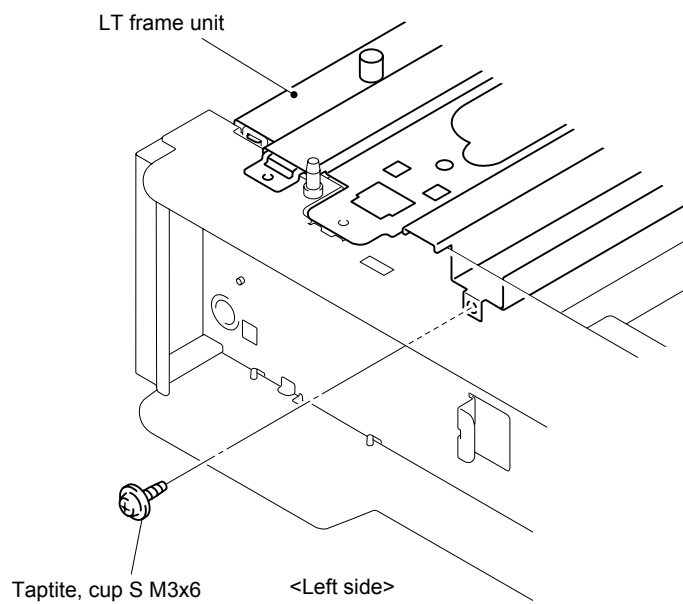

Fig. 3-260

(17) Remove the LT paper feed frame unit from the LT frame unit by 17a and 17b.

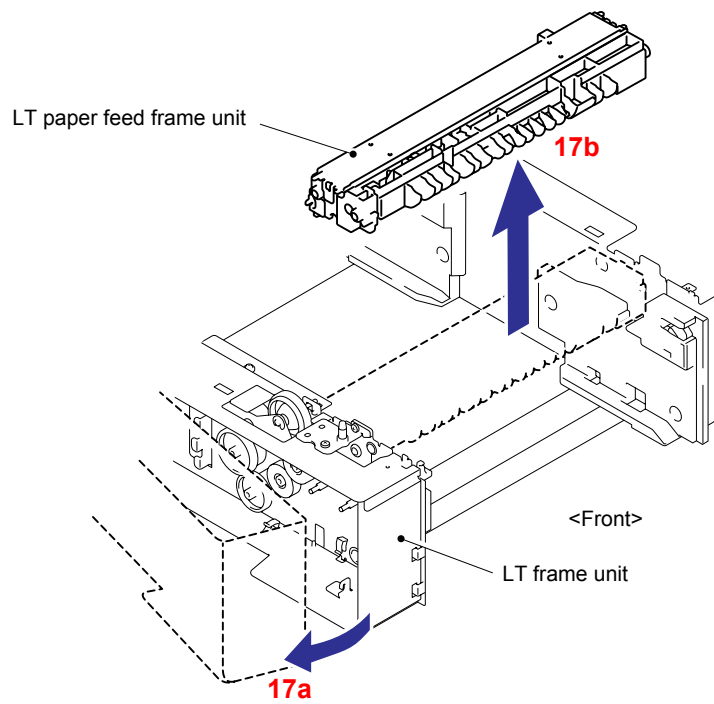

Fig. 3-261

CHAPTER 4 ADJUSTMENTS AND UPDATING OF SETTINGS, REQUIRED AFTER PARTS REPLACEMENT

1. IF YOU REPLACE THE MAIN PCB

< What to do when replacing the main PCB >

- **Rewriting the Firmware (Main Firmware, Sub Firmware (PCL/PS))**
- **EEPROM Parameter Initialization of the Main PCB (Maintenance Mode: Code 01)**
- **Operational Check of Control Panel Button (Maintenance Mode: Code 13)**
- **Operational Check of Sensors (Maintenance Mode: Code 32)**
- **Acquisition of White Level Data (Maintenance Mode: Code 55)**
- **EEPROM Customizing of the Main PCB (Maintenance Mode: Code 74)**
- **Setting the Serial Number**
- **Performing the Auto Registration**

< Which parts to use >

Main PCB: The table below shows the ROM type.

Main PCB (For a spare parts)	ROM 0 (16 Mbyte)	Main Firmware (Controller Program, Network Program)
	ROM 1 (8 Mbyte)	Sub Firmware (PCL/PS) (Emulation, Font data)

< What you need to prepare >

- (1) Computer (Windows® XP/2000)
Create a folder on the C drive, for example: - (AC FIRMWARE)
- (2) A USB flash memory drive
- (3) The Firmware

Main Firmware: LZ1011_A.djf or LZ1011_A.upd	LZXXXX_\$.djf or LZXXXX_\$.upd
Sub Firmware (PCL/PS): LZ0828_A.djf or LZ0828_A.upd	LZXXXX: First six digits are a parts number of the firmware. \$: Alphabet representing the revision of the firmware.

- (4) The Maintenance Tool (Mainte.EXE)
Copy it into the folder that has been created on the C drive. Extract the copied file and run "brmainte.exe" file by double-clicking it.
- (5) A USB cable
- (6) The Download Utility (FILEDG32.EXE)
Copy it into the folder that has been created in the C drive.
- (7) The Brother Maintenance USB Printer Driver
Copy it into the folder that has been created on the C drive and extract the copied file.

<Procedures>

■ Rewriting the Firmware (Main Firmware, Sub Firmware (PCL/PS))

- How to rewrite the firmware by using the USB flash memory drive

(For the model with a USB direct interface)

If you save program files in the USB flash memory drive and plug it into the USB direct Interface, you can rewrite the firmware and set the country.

Note:

- Make sure that the USB flash memory drive has enough space to save the program file.
- In order to verify the data list saved in the USB memory, press the ▲ or ▼ button after the message described in Step (4) appears on the LCD, and check the list shown on the LCD.

- (1) Save the necessary program files (such as Main firmware (djf file) and Sub firmware (PCL/PS) (djf file)) to rewrite them into the USB flash memory drive.
- (2) Connect the USB flash memory drive to the USB direct interface on the front of the machine.

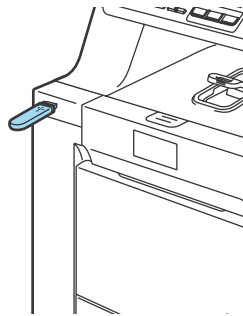

Fig. 4-1

- (3) When the machine has recognized the USB flash memory drive, the **Direct** button lights blue. Press the **Direct** button.
- (4) “Direct Print” is displayed on the first line of the LCD, and the file names will be shown on the second or lower line of the LCD. Press the ▲ or ▼ button to choose the necessary program file, and press the **OK** button.
- (5) “Program Update/ Press OK” appears on the LCD. Press the **OK** button to start. The “Program Updating/ Do not turn OFF” message appears on the LCD with Data LED blinking while rewriting the firmware. DO NOT turn off the machine.
- (6) After completion of firmware rewriting, the machine will reboot automatically. “Direct Print” is displayed on the first line of the LCD, and the file names will be shown on the second line of the LCD again.
- (7) Choose the necessary program file to rewrite next, and then follow the steps from (4) to (6).

Note:

It is recommended to rewrite 1) Sub firmware (PCL/PS) and 2) Main firmware. In this order.

- (8) Remove the USB flash memory drive from the USB direct interface once the update have finished.

Note:

When pressing the * and # buttons at the same time, you can check the firmware version of the Main Program on the LCD.

- How to rewrite the firmware by using the “FILEDG32.EXE”

(For the model without a USB direct interface)

If the model without a USB direct interface is used, rewriting the firmware using a USB flash memory drive fails and an error message appears on the LCD, or no message appears on the LCD, it will be necessary to rewrite the firmware using the “FILEDG32.EXE”. Follow the steps below.

< Installing the maintenance driver >

To identify machines connected via USB direct interface, the PC requires the corresponding driver for the virtual USB device. If you connect any number of machines to your PC, the same number of virtual USB devices will be automatically configured on your PC. To prevent many virtual USB devices from being configured, use the unique driver installation procedure described below that enables your PC to identify terminals via one single virtual USB device.

Note:

- Once this installation procedure is carried out for a PC, no more driver/software installation will be required for that PC to identify machines. If the Brother Maintenance USB Printer driver has been already installed to your PC according to this procedure, skip this section.
- Before proceeding to the procedure given below, make sure that the Brother Maintenance USB Printer driver is stored in your PC.

- (1) Check that the power switch of the machine is turned off. Disconnect the USB cable that connects the machine with PC.
- (2) Turn on your PC.
- (3) Turn on the power switch of the machine.
- (4) Press the **Menu** and **Black Start** buttons. Next press the **▲** button four times to make the machine enter the maintenance mode. (Refer to “1.1 How to Enter the Maintenance Mode” in Chapter 5.)

TIP:

FAX models equipped with numerical keypads can enter the maintenance mode in the same way as conventional models; that is, by pressing the **Menu**, *, **2**, **8**, **6** and **4** buttons in this sequence.

- (5) Connect the machine to your PC using the USB cable. The following window appears.

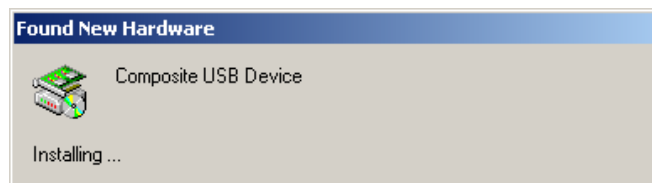

- (6) The following screen appears, indicating the detection of new hardware device by the system. Select “No, not this time.” And click **Next**.



- (7) Select “Install the software automatically (Recommended)” and click **Next**.

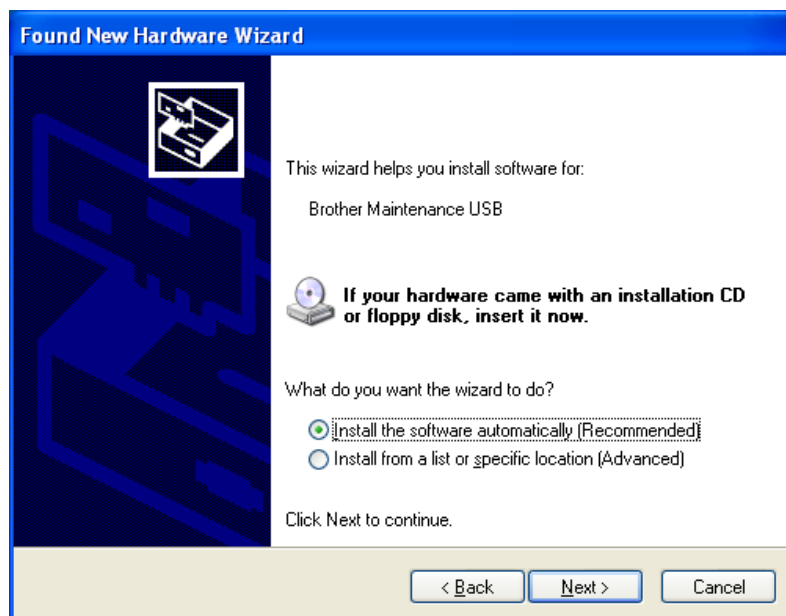

- (8) Alert warning message of WHQL appears, Click **Continue Anyway** to proceed.

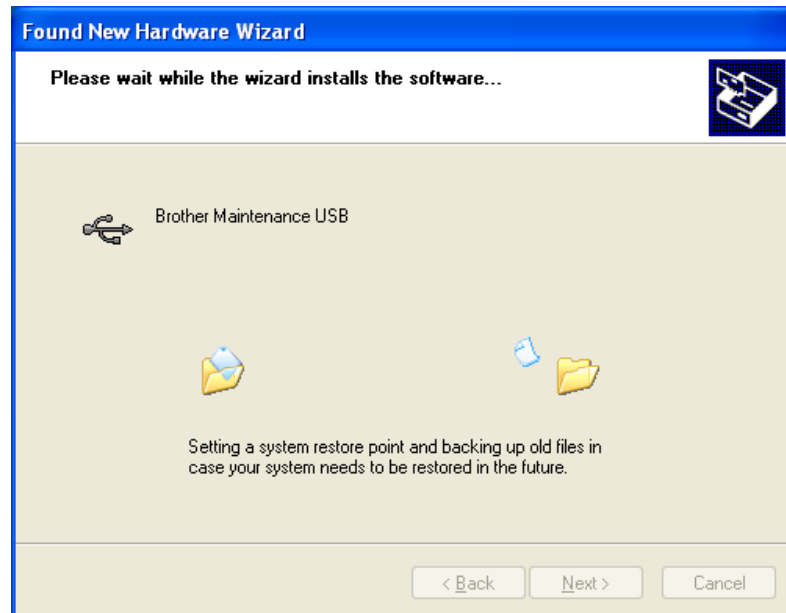

- (9) If the Brother Maintenance USB Printer driver is successfully installed, the following message screen appears. Click **Finish** to return.



Note:

In order to check whether the printer driver is successfully installed, click **Start**, **Settings** and **Printers** and select the Printers window. Then, check that the Brother Maintenance USB Printer icon is shown.

- (10) Repeat the steps from (7) to (9) three times, and then complete its installation.

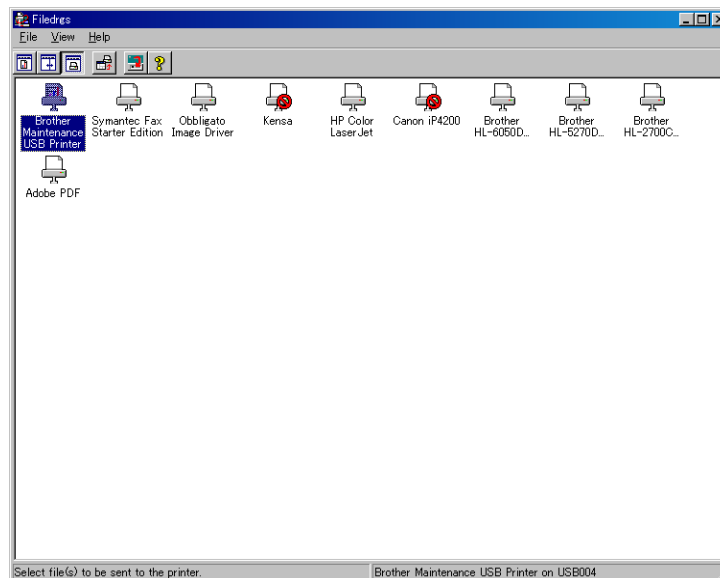

< How to rewrite the firmware (Main Firmware and Sub Firmware (PCL/PS)) >

After the installation procedure of the Brother Maintenance USB Printer driver is completed, refer to the following steps for the detailed procedures to rewrite the program files. If the Brother Maintenance USB Printer Driver has already been installed to your PC according to this procedure, start to rewrite the program files.

Note:

- DO NOT unplug the power cord of the machine or your PC or disconnect the USB cable while rewriting the program files.
- If you are using the "FILEDGD32.EXE", the following firmware files are needed to rewrite the firmware.

Main Firmware: LZ1011_A.djf	LZXXXX_\$.djf LZXXXX: First six digits are a parts number of the firmware.
Sub Firmware (PCL/PS): LZ0828_A.djf	\$: Alphabet representing the revision of the firmware.

■ Rewriting the Sub Firmware (PCL/PS)

- (1) Press the **Menu** and **Black Start** buttons. Next press the **▲** button four times to make the machine enter the maintenance mode. (Refer to "1.1 How to Enter the Maintenance Mode" in Chapter 5.)

TIP:

FAX models equipped with numerical keypads can enter the maintenance mode in the same way as conventional models; that is, by pressing the **Menu**, *****, **2**, **8**, **6** and **4** buttons in this sequence.

- (2) Connect the computer to the machine with the USB cable.
- (3) Double-click the "FILEDGD32.EXE" to start. The following screen appears.

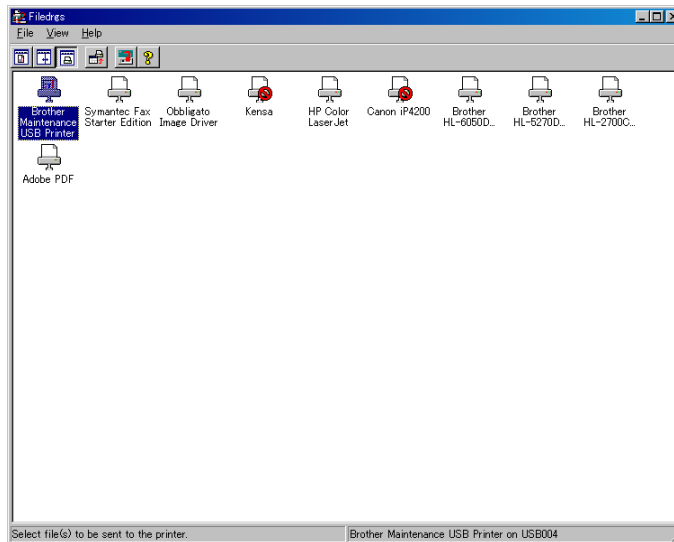

- (4) Drag the necessary firmware program file such as LZ0828_A.djf and drop it onto the Brother Maintenance USB Printer icon. "Program Updating" will appear on the LCD.
- (5) Upon completion of rewriting, the machine is rebooted and returns to the Ready state automatically.

■ Rewriting the Main Firmware

- (1) Press the **Menu** and **Black Start** buttons. Next press the **▲** button four times to make the machine enter the maintenance mode. (Refer to “1.1 How to Enter the Maintenance Mode” in Chapter 5.)

TIP:

FAX models equipped with numerical keypads can enter the maintenance mode in the same way as conventional models; that is, by pressing the **Menu**, *****, **2**, **8**, **6** and **4** buttons in this sequence.

- (2) Connect the computer to the machine with the USB cable.
- (3) Double-click the “FILEDGD32.EXE” to start. The following screen appears.

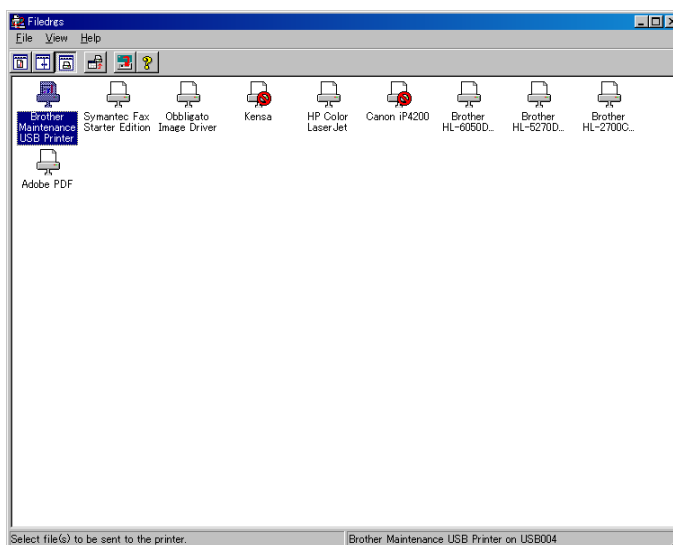

- (4) Drag the necessary firmware program file such as LZ1011_A.djf and drop it onto the Brother Maintenance USB Printer icon. “Program Updating” will appear on the LCD.
- (5) Upon completion of rewriting, the machine is rebooted and returns to the Ready state automatically.

How to rewrite the main firmware again if failing to rewrite it

Note:

If failing to rewrite the main firmware, prepare the upd file.

- (1) Turn the power switch of the machine off. Then, turn it on while pressing the **5** button. “■■■■■■■■■■” appears on the LCD.
- (2) Start the “FILEDGD32.EXE” by double clicking the icon to start.
- (3) Drag the necessary firmware program file such as LZ1011_A.upd and drop it onto the Brother Maintenance USB Printer icon. The machine will emit audible beeps.
- (4) Upon completion of rewriting, the machine is rebooted and returns to the Ready state automatically.
- (5) Press the ***** and **#** buttons at the same time and check the firmware version. If the indicated version coincides with the rewritten one, rewriting is successfully completed. If rewriting has failed, rewrite the files from step (1) again.

■ **EEPROM Parameter Initialization of Main PCB (Maintenance Mode: Code 01)**

Refer to “1.4.1 EEPROM Parameter Initialization” in Chapter 5, and perform the EEPROM parameter Initialization of main PCB.

■ **Operational Check of Control Panel Button (Maintenance Mode: Code 13)**

Refer to “1.4.8 Operational Check of Control Panel Button” in Chapter 5, and perform the operational check of control panel PCB.

■ **Operational Check of Sensors (Maintenance Mode: Code 32)**

Refer to “1.4.11 Operational Check of Sensors” in Chapter 5, and perform the operational check of sensors.

■ **Acquisition of White Level Data (Maintenance Mode: Code 55)**

Refer to “1.4.16 Acquisition of White Level Data” in Chapter 5, and perform the acquisition of white level data.

■ **EEPROM Customizing of Main PCB (Maintenance Mode: Code 74)**

Refer to “1.4.20 EEPROM Customizing” in Chapter 5, and perform the EEPROM Customizing.

For models in France and surrounding countries, Pan-Nordic, East Europe, Oceania or Iberia, implement the setting for Code 74 in Maintenance mode first. Then, implement more detailed settings for Code 52.

■ **Setting the Serial Number**

- (1) Connect the computer to the machine with the USB cable.
- (2) Double-click the brmainte.exe file (maintenance utility) which has been copied in the folder to start.
Select “Input Information” from Menu. Select the applicable model name.

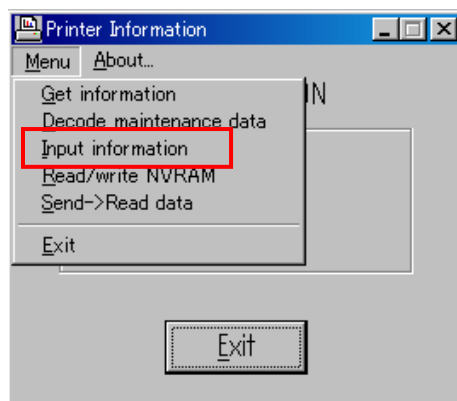

- (3) Check the port (USB) that the machine is connected through and click “Serial No.” in the lower box.

Enter the serial number (the last nine digits) of the machine into the box on the right hand side and click the **OK** button.

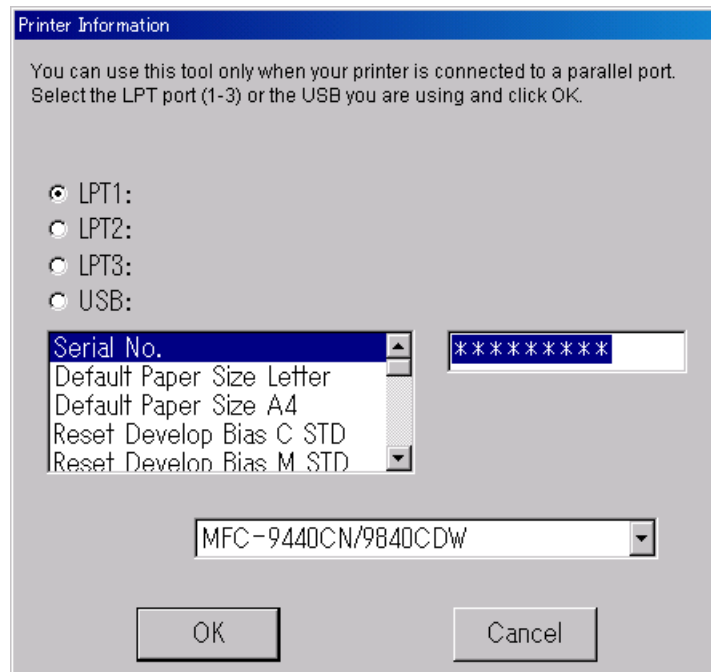

A confirmation window opens and shows the serial number. Check that it is correct and click the **OK** button.

Note:

Refer to “[Appendix 3 SERIAL NUMBER SYSTEM](#)” to know how to read the serial number of the machine.

■ **Performing the Auto Registration**

Select “Printer”, “Auto Regist.” and “Registration” from Menu and perform the auto registration.

2. IF YOU REPLACE THE ENGINE PCB

< What to do when replacing the engine PCB >

- Rewriting the Firmware (Engine Firmware)
- Performing the Color Calibration
- Performing the Auto Registration

< Which parts to use >

- Engine PCB: The table below shows the ROM type.
- Flash ROM 0 (512 Kbyte): Engine firmware

< What you need to prepare >

- (1) Computer (Windows® XP/2000)
Create a folder on the C drive, for example: - (AC FIRMWARE)
- (2) A USB flash memory drive
- (3) The Firmware

Engine firmware: LZ0833_A.djf	LZXXXX_\$.djf LZXXXX: First six digits are a parts number of the firmware. \$: Alphabet representing the revision of the firmware.
----------------------------------	--

< Procedures >

■ Rewriting the Firmware (Engine Firmware)

- How to rewrite the firmware by using the USB flash memory drive

(For the model with a USB direct interface)

Note:

- Make sure that the USB flash memory drive has enough space to save the program file.
- If you want to print an index of the files, choose "Index Print". The "Index Print" selection can be found after you scroll down through all the file names. Press the **OK** button.

- (1) Save the necessary program file (Engine firmware) to rewrite it into the USB flash memory drive.
- (2) Connect the USB flash memory drive to the USB direct Interface on the front of the machine.

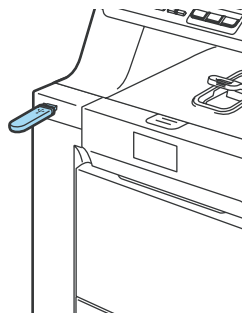

Fig. 4-2

- (3) When the machine has recognized the USB flash memory drive, the “Checking device/ Please wait” message appears on the LCD.
- (4) “Direct Print” is displayed on the first line of the LCD, and the file names will be shown on the second line of the LCD. Press the ▲ or ▼ button to choose the necessary program file, and press the **OK** button.
- (5) “Program Update/ Press Go” appears on the LCD. Press the **OK** button to start. The “Program Updating/ Do not turn OFF” message appears on the LCD with Data LED blinking while rewriting the firmware. DO NOT turn off the machine.
- (6) After completion of firmware rewriting, the machine will reboot automatically. “Direct Print” is displayed on the first line of the LCD, and the file names will be shown on the second line of the LCD again.
- (7) Remove the USB flash memory drive from the USB direct Interface once the update have finished.

Note:

- Enter the maintenance mode. (Refer to “1.1 How to Enter the Maintenance Mode” in Chapter 5.) Then, press the **2** and **5** buttons in this order and press the **Black Start** button twice so that the firmware version of the engine firmware can be checked.
- If rewriting the firmware using a USB flash memory drive fails, turn the power of the machine off and on. Follow the steps 1 to 7 again.

- How to rewrite the firmware by using the “FILEDG32.EXE”

(For the model without a USB direct interface)

Note:

- DO NOT unplug the power cord of the machine or your PC or disconnect the USB cable while rewriting the program files.
- In case of using the “FILEDG32.EXE”, the following firmware files are necessary to rewrite.

Engine firmware: LZ0833_A.djf	LZXXXX_\$.djf LZXXXX: First six digits are a parts number of the firmware. \$: Alphabet representing the revision of the firmware.
----------------------------------	--

- (1) Turn on the power switch of the machine. Press the **Menu** and **Black Start** buttons. Next press the ▲ button four times to make the machine enter the maintenance mode. (Refer to “1.1 How to Enter the Maintenance Mode” in Chapter 5.)

TIP:

FAX models equipped with numerical keypads can enter the maintenance mode in the same way as conventional models; that is, by pressing the **Menu**, *****, **2**, **8**, **6** and **4** buttons in this sequence.

- (2) Connect the machine to your PC using the USB cable.

- (3) Double-click the “FILEDG32.EXE” to start. The following screen appears.

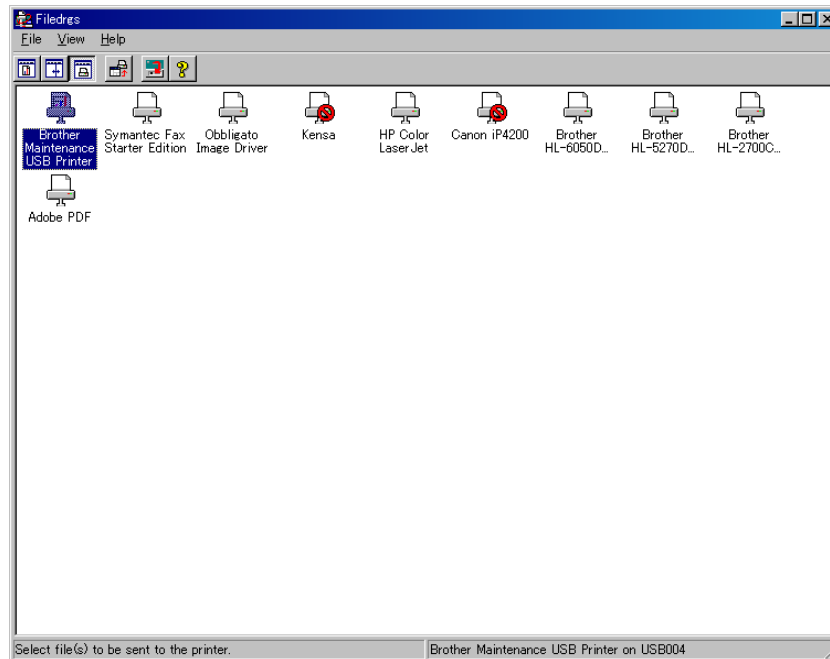

- (4) Drag the necessary firmware program file such as LZ0833_A.djf and drop it onto the Brother Maintenance USB Printer icon. “Program Updating” will appear on the LCD. “Program Updating” will appear on the LCD and the machine emits audible beeps.
- (5) Upon completion of rewriting, the machine is rebooted and returns to the Ready state automatically. Disconnect the USB cable and complete the procedure.

■ Performing the Color Calibration

Select “Printer”, “Calibration” and “Calibrate” from Menu and perform the color calibration.

■ Performing the Auto Registration

Select “Printer”, “Auto Regist.” and “Registration” from Menu and perform the auto registration.

3. IF YOU REPLACE THE TRANSFER HVPS PCB UNIT OR REGISTRATION-MARK SENSOR PCB ASSY 1, 2

<What to do when replacing the transfer HVPS PCB unit or registration-mark sensor PCB ASSY 1, 2>

■ Adjustment of Color Registration (Function code 66)

<Procedures>

■ Adjustment of Color Registration (Function code 66)

Refer to “1.4.17 Adjustment of Color Registration” in Chapter 5, and perform the automatic adjustment of color registration.

Note:

If an error occurs after executing Function code 66, upgrade the firmware to the latest one. (Refer to “Rewriting the firmware (Main firmware, Sub firmware (PCL/PS))” in this chapter.) After upgrading the firmware, execute Function code 66 again.

4. IF YOU REPLACE THE LASER UNIT

<What to do when replacing the laser unit>

When an old-type laser unit is replaced with a new laser unit, it is necessary to rewrite the firmware. Make sure to rewrite the firmware with the following procedure.

< How to identify old and new laser unit >

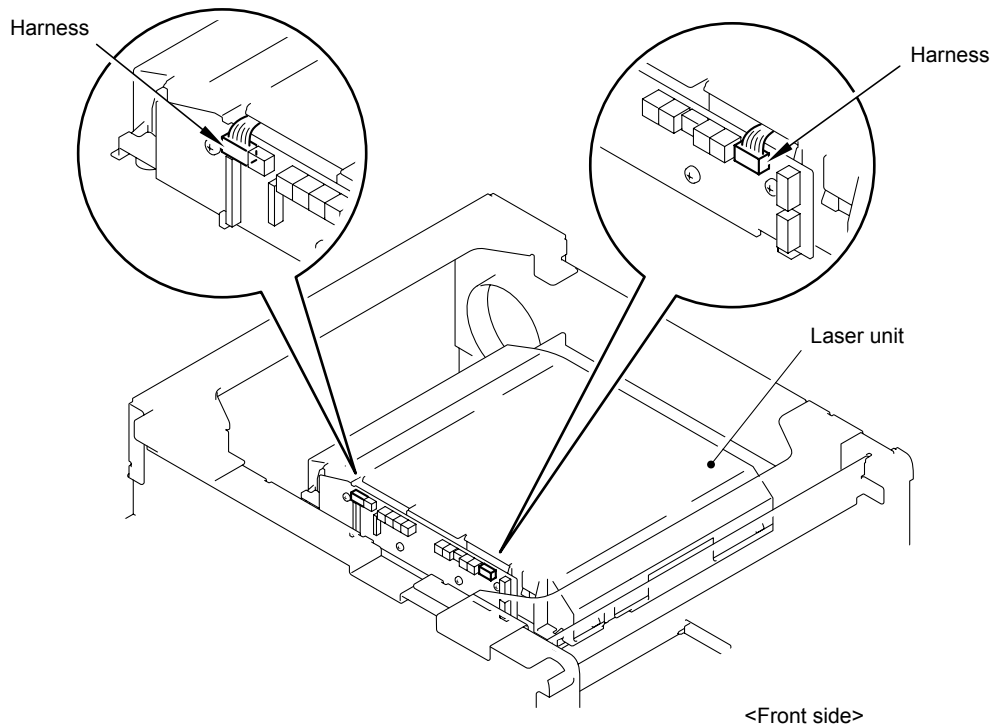

Fig. 4-3

Check the colors of the harnesses shown in the figure above.

Old: Red, Blue, White, Blue, White

New: Brown, Red, Orange, Yellow, Green

<Procedures>

■ Rewriting the firmware (Main firmware, Sub firmware (PCL/PS), Engine firmware)

Refer to “[Rewriting the firmware \(Main firmware, Sub firmware \(PCL/PS\)\)](#)”, “[Rewriting the firmware \(Engine firmware\)](#)” in this chapter and rewrite it.

CHAPTER 5 SERVICE FUNCTIONS

1. MAINTENANCE MODE

The maintenance mode is exclusively designed for the checking, settings and adjustments of the machine by using the buttons on the control panel. You can customize the EEPROM according to the shipment destination of the machine concerned. In addition, you can perform operational checks of the LCD, control panel PCB and sensors, perform a print test, display the log information and error codes, and modify worker switches (WSW).

1.1 How to Enter the Maintenance Mode

Press the **Menu** and **Black Start** buttons. Next press the **▲** button four times to make the machine enter the maintenance mode.

TIP:

This machine can enter the maintenance mode in the same way as conventional models; that is, by pressing the **Menu**, *****, **2**, **8**, **6** and **4** buttons in this sequence.

The machine beeps for approx. one second and displays “■■ MAINTENANCE ■■■” on the LCD, indicating that it is placed in the initial stage of the maintenance mode, a mode in which the machine is ready to accept entry from the buttons.

Note:

- To exit from the maintenance mode and switch to standby, press the **9** button twice in the initial stage of the maintenance mode.
- Pressing the **Stop/Exit** button after entering only one digit restores the machine to the initial stage of the maintenance mode.
- If an invalid function code is entered, the machine beeps for one second and returns to the initial stage of the maintenance mode.

1.2 How to Enter the End User-accessible Maintenance Mode

Basically, the maintenance-mode functions listed in the [next page](#) should be accessed by service personnel only. However, you can allow end users to access some of these under the guidance of service personnel by phone, for example.

The end user-accessible functions are **shaded** in the table given on the [next page](#). (codes [06](#), [09](#), [10](#), [11](#), [12](#), [25](#), [31](#), [45](#), [52](#), [53](#), [54](#), [72](#), [75](#), [77](#), [80](#), [82](#), [87](#) and [91](#))

Function code 10 accesses the worker switches, each of which has eight selectors. You should not allow end users to access all of those selectors, but you can allow them to access user-accessible selectors which are **shaded** in the worker switch tables in [Appendix 1](#).

The service personnel should instruct end users to follow the procedure given below.

- (1) Press the **Menu**, **Black Start**, **Menu**, and **▲** buttons in this order. The “MAINTENANCE 06” appears on the LCD.
- (2) To access any other function code, call up the desired code using the **▲** and **▼** buttons or numerical buttons. Then press the **OK** button.

To switch the machine back to the standby state, press the **Stop/Exit** button. When each of the user-accessible functions is completed, the machine automatically returns to the standby state.

Note:

Although Function code 72 is indicated on the LCD, do not use it.

1.3 List of Maintenance-mode Functions

Function Code	Function	Refer to:
01	EEPROM Parameter Initialization	1.4.1 (5-3)
05	Printout of Scanning Compensation Data	1.4.2 (5-4)
06	Placement of Scanner Unit Position for Transportation	1.4.3 (5-7)
08	ADF Performance Test	1.4.4 (5-7)
09	Test Pattern	1.4.5 (5-8)
10	Worker Switch (WSW) Setting	1.4.6 [1] (5-9)
11	Printout of Worker Switch Data	1.4.6 [2] (5-11)
12	Operational Check of LCD	1.4.7 (5-12)
13	Operational Check of Control Panel Button	1.4.8 (5-13)
25	ROM Version Check	1.4.9 (5-14)
31	Drum Unit Cleaning	1.4.10 (5-15)
32	Operational Check of Sensors	1.4.11 (5-16)
45	Switching of the USB Transfer Speed in the PictBridge Mode	1.4.12 (5-20)
52	EEPROM Customizing (User-accessible)	1.4.13 (5-21)
53	Received Data Transfer Function	1.4.14 (5-22)
54	Fine Adjustment of Scan Start/End Positions	1.4.15 (5-24)
55	Acquisition of White Level Data	1.4.16 (5-25)
66	Adjustment of Color Registration	1.4.17 (5-26)
67	Paper Feeding and Ejecting Test	1.4.18 (5-28)
72	Sensitivity Adjustment of Density Sensor (Don't use)	1.4.19 (5-28)
74	EEPROM Customizing	1.4.20 (5-29)
75	Sensitivity Adjustment of Registration-mark Sensor	1.4.21 (5-31)
77	Printout of Maintenance Information	1.4.22 (5-33)
78	Operational Check of Fans	1.4.23 (5-34)
80	Display of the Machine's Log	1.4.24 (5-36)
82	Error Code Indication	1.4.25 (5-38)
83	Developing Bias Voltage Correction	1.4.26 (5-38)
87	Output of Transmission Log to the Telephone Line	1.4.27 (5-39)
91	EEPROM Parameter Initialization	1.4.1 (5-3)
99	Exit from the Maintenance Mode	1.4.28 (5-39)
---	Cancellation of the Memory Security Mode (Not applicable to the Japanese version)	

* The functions shaded in the table above are user-accessible.

1.4 Detailed Description of Maintenance-mode Functions

1.4.1 EEPROM Parameter Initialization (Function code 01, 91)

<Function>

The machine initializes the parameter, user switches, worker switches and assurance mode switch settings registered in the EEPROM, to the initial values. Entering function code 01 initializes almost all of the EEPROM areas, but entering 91 does not initialize some areas, as listed below.

Function code	01	91
Data item		
Maintenance-mode functions User switches Worker switch (Refer to Appendix 1.)	All of these will be initialized.	These will be initialized.
Remote activation code Registered message for cover page comment Forwarding / paging number, PIN number Outside line number Telephone function registration One-touch dialing Speed dialing Group dialing		These will not be initialized.

Note:

If you replace the main PCB with the one used for any other machine, carry out this procedure and then customize the EEPROM (maintenance-mode function code 74 in [Section 1.4.20](#)).

<Operating Procedure>

- (1) Press the **0** and **1** buttons (or the **9** and **1** buttons according to your need) in this order in the initial stage of the maintenance mode.
The "PARAMETER INIT" will appear on the LCD.
- (2) Upon completion of parameter initialization, the machine beeps for one second and returns to the initial stage of the maintenance mode.

1.4.2 Printout of Scanning Compensation Data (Function code 05)

<Function>

The machine prints out the black and white level data for scanning compensation.

<Operating Procedure>

Do not start this function merely after powering on the machine but start it after carrying out a sequence of scanning operation. Unless the machine has carried out any scanning operation, this function cannot print out correct scanning compensation data. This is because at the start of scanning operation, the machine initializes black and white level data and takes in the scanning compensation reference data. The printout varies depending on whether black and white or color scanning is performed immediately before this operation. Check the black and white level data you want to print out before the operation.

- (1) Take a black and white copy for black and white scanning, and take a color copy for color scanning.
- (2) Press the **0** and **5** buttons in this order in the initial stage of the maintenance mode. The "PRINTING" will appear on the LCD.
- (3) The machine prints out the scanning compensation data list containing the following:

■ Black and white scanning

- | | |
|--------------------------------------|--|
| a) Black and white data graph | |
| b) LED PWM data | 1Byte |
| c) LED pulse data (G) | 2Byte |
| d) RLCV (AFE parameter) | 1Byte |
| e) OFFSET (AFE parameter) | 1Byte |
| f) GAIN (AFE parameter) | 2Byte |
| g) Background color compensated data | 1Byte |
| h) Black level data | Depends on the number of pixels of the previous scanning |
| i) White level data (G) | Depends on the number of pixels of the previous scanning |
| j) White level data (B) | Depends on the number of pixels of the previous scanning |
| k) White level data (R) | Depends on the number of pixels of the previous scanning |

■ Color scanning

- | | |
|--------------------------------------|--|
| a) Black and white data graph | |
| b) LED PWM data | 1Byte |
| c) LED pulse data (G) | 2Byte |
| d) LED pulse data (B) | 2Byte |
| e) LED pulse data (R) | 2Byte |
| f) RLCV (AFE parameter) | 1Byte |
| g) OFFSET (AFE parameter) | 1Byte |
| h) GAIN (AFE parameter) | 2Byte |
| i) Background color compensated data | 1Byte |
| j) Black level data | Depends on the number of pixels of the previous scanning |
| k) White level data (R) | Depends on the number of pixels of the previous scanning |
| l) White level data (G) | Depends on the number of pixels of the previous scanning |
| m) White level data (B) | Depends on the number of pixels of the previous scanning |
- (4) Upon completion of recording of the compensation data list, the machine beeps for one second and returns to the initial stage of the maintenance mode.

■ Color scanning

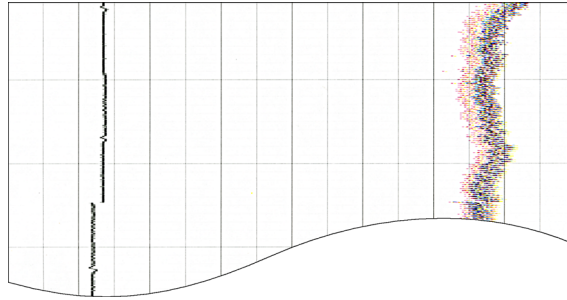

```

LED PWM : 4f
LED PULSE G: 0a0b
AFE RLCV
AFE OFFSET
AFE GAIN
BACK DATA
4390f400 : 26 26 26 26 26 26 26 26 26 26 26 26 26 26
4390f420 : 26 26 26 26 26 27 27 26 26 26 26 26 26 26
4390f440 : 26 26 26 25 25 26 26 26 26 26 26 26 26 26
4390f460 : 26 26 26 25 25 26 26 26 26 26 26 26 26 25
4390f480 : 26 26 26 26 26 26 27 26 26 26 26 26 26 26
4390f4a :
4390f4c 438fe400 : da db db db db d5 d5 d5 d5 d6 d7 d9 db dd
4390f4e 438fe420 : dc df dc d9 db d5 d7 d3 d5 d6 d7 d9 dc dd db
4390f50 438fe440 : dd da d6 d7 d5 d6 d4 d6 d9 da db de df de dd dc
4390f52 438fe460 : db d7 d5 d6 d7 d8 db da dd e2 df de de dd dc
4390f54 438fe480 : d9 d9 d9 da da db dc dd de df dd de db d7 d5
4390f56 438fe4a0 : d7 d7 da d8 dd e0 e2 e3 e2 de dc dd da da dc
4390f58 438fe4c0 : da dc dc df df e0 df df dd db d8 d8 d6 d6 da d9
4390f5a 438fe4e0 : dc dd df df e0 dd dc d8 d9 d8 d9 d9 db de dd
4390f5c 438fe500 : e8 e0 e3 e2 df dd dc db da da da da da da e3
4390f5e 438fe520 : e2 e2 de db dc db dc db da da da da da da
4390f60 438fe540 : e0 df dc d9 da da da da da da da da da da
4390f62 438fe560 : da da d9 d8 da da da da da da da da da da
4390f64 438fe580 : d7 d5 d6 d7 d8 da da dc dc d9 d8 d6 d5
4390f66 :
4390f68 438fe5a0 : da da da da da da da da da da da da da da
4390f6a 438fe5c0 : da da da da da da da da da da da da da da
4390f6c 438fe5e0 : dc de e0 df de dd d8 d9 da d7 d7 d6 d7 d8 dc de
4390f6e 438fe600 :
4390f70 438fe620 :
4390f72 438fe640 438fec00 : e5 e7 e5 e2 df de de df de e0 e2 e3 e4 e5 e6 e7
4390f74 438fe660 438fec20 : e7 e4 e0 df dd de de de df e0 e1 e2 e4 e5 e6 e3 e2
4390f76 438fe680 438fec40 : df dd de dd dd de de de e2 e2 e5 e8 e6 e5 e3 e1 e0
4390f78 438fe6a0 438fec60 : df df df df e0 e2 e0 e4 e5 e5 e6 e3 e0 e0 de de
4390f7a 438fe6c0 438fec80 : df de df e1 e6 e4 e5 e7 e4 e1 e0 dd dc db
4390f7c 438fe6e0 438feca0 : de df de e2 e4 e4 e5 e4 df de db dd db dc de dc
4390f7e 438fe700 438fec00 : e0 e2 e2 e5 e1 e3 de dd db da da da da da dd df e1
4390f80 438fe720 438feca0 : e3 e3 e7 e5 e2 df e0 df e1 dd df df e1 e2 e5 e5
4390f82 438fe740 438fed00 : e7 e7 e5 e2 e0 e0 e1 de dc e0 de e1 e3 e7 e6 e4
4390f84 438fe760 438fed20 : e4 e1 df de dd dd de db de e2 e2 e4 e3 df dd dc da da
4390f86 438fe780 438fed40 : db dd dd dc db dc de e0 e2 e5 e5 e4 e2 e1 dd db
4390f88 438fe7a0 438fed60 : da db da dc da dd e0 e2 e2 e4 e3 df dd dc da da
4390f8a 438fe7c0 438fed80 : da db dd de df e1 e3 e3 e2 e2 dd db da d8 db d6
4390f8c 438fe7e0 438fed00 : da db db e0 e2 e5 e2 e1 dd dc da d9 d8 d7 db dd
4390f8e 438fe800 438fedc0 : dd df e3 e1 e2 df dd dc db da da db db dc df df
4390f90 438fe820 438fed20 : e1 e6 e3 e1 e2 dd de dc d9 d9 da d8 cc dd df e2 e0
4390f92 438fe840 438fee00 : e4 e2 df dd d9 d9 d7 d9 da d8 cc dd df e2 e0
4390f94 438fe860 438fee20 : e0 de db d8 da d7 d6 d9 da dd df df e0 de dc
4390f96 438fe880 438fee40 : d9 d5 d9 d8 d7 d8 d8 dc dd df e2 e0 de da da
4390f98 438fe8a0 438fee60 : d9 d6 d7 d9 db db dd de e3 e4 e1 dd dc d9 d8 d7
4390f9a 438fe8c0 438fee80 : d7 d9 d6 d8 da dd df df e0 de dd da d6 d9 d6 d6
4390f9c 438fe8e0 438feea0 : da d8 dd df df e0 df db d9 d7 d8 d9 da da da
4390f9e 438fe900 438feec0 : de e0 e3 e5 e3 e1 e0 db dc db da db da dc de e0
4390fa0 438fe920 438fee00 : e3 e1 e0 e1 de db db d8 d7 d9 d8 da da df e0 e2
4390fa2 438fe940 438fef00 : e3 e1 e0 da db da d8 d9 d9 db dc dd df e1 e1 e0
4390fa4 438fe960 438fef20 : df de db da da da d8 d9 dc de e0 e4 e4 e2 df
4390fa6 438fe980 438fef40 : dc dd dd db dd dc df dd e2 e3 e4 e2 de dc d9
4390fa8 438fe9a0 438fef60 : da da d9 cc dd de df e4 e3 e4 e0 e1 cc dd dc dc
4390faa 438fe9c0 438fef80 : dc dc dd df de e1 e2 e4 e1 d7 dc da db d9 db db
4390fac 438fe9e0 438fefa0 : dc e1 e1 e5 e7 e5 e4 e3 e0 df df de dd de e0 e1
4390fab 438fea20 438fefc0 : e5 e9 e8 e6 e3 df df dd de dd dd e0 e5 e5
4390fbd 438fea40 438fef20 : e5 e9 e7 e6 e3 de de df df de de df e2 e7 e9
4390fbd 438fea60 438fef40 : e7 e6 e2 e1 e0 de df e0 e1 e1 e7 ea e8 ea e9 e7
4390fbd 438fea80 438fef60 : e4 e4 e1 e1 e1 df e2 e1 e5 e7 e8 eb e8 e9 e5 e2
4390fbd 438fea0 438fef80 : e2 e1 df de de e0 e5 e9 e9 ec eb ea e9 e4 e1 e1
4390fbd 438fea20 438fef00 : e1 e0 e0 e4 e6 e7 e3 e9 ed eb e9 e3 e0 df de dc
4390fbd 438fea40 438fef20 : df e2 e2 e4 e7 e8 eb e6 e5 e2 e2 e0 e0 e0 e1
4390fbd 438fea60 438fef40 : e3 e3 e7 eb eb e3 e8 e5 e3 df e0 e0 e0 df e1 e5
4390fbd 438fea80 438fef60 : e8 eb ea eb ea e8 e4 e5 e2 df e0 e4 e5 e3 e7 e9
4390fbd 438fea0 438fef80 : eb ec e9 ea e5 e4 e4 df e2 e1 e4 e1 e5 e8 e8 ec
4390fbd 438fea20 438fef00 : ea e7 e5 e2 e1 de df df e1 e3 e4 e5 e4 e7 ea e7
4390fbd 438fea40 438fef20 : e4 e0 e0 de dd de de e2 e0 e2 e6 e7 e6 e5 e4 e1
4390fbd 438fea60 438fef40 : de de dc df df e3 e3 e4 e9 e8 e5 e4 e0 de de
4390fbd 438fea80 438fef60 : de de df e1 e3 e5 e6 e7 e6 e6 e3 e2 df de da
4390fbd 438fea0 438fef80 : dd de df e4 e6 e5 e7 e7 e5 e3 de dd dd dd dd db
4390fbd 438fea20 438fef00 : df de e5 e6 e6 e3 e7 e2 e1 df de dc de dc de e2
4390fbd 438fea40 438fef20 : e4 e5 e5 e6 e6 e5 df de dd dd df df dd df e0 e4
4390fbd 438fea60 438fef40 : e5 e5 e5 de dc dc da de dd df e3 e7 e4
4390fbd 438fea80 438fef60 : e5 e3 e0 de dd db d9 db dd de df e2 e5 e6 e5
4390fbd 438fea0 438fef80 : e1 de de dc dc dd dc e1 e1 e6 e6 e6 e6 e7 e3 e3
4390fbd 438fea20 438fef00 : e0 df dc de df e0 e1 e5 e6 e8 e7 e5 e5 e3 e0 e0
4390fbd 438fea40 438fef20 : df de df e0 e0 e5 e8 ea ea e9 e8 e5 e3 e2 e0 e0
4390fbd 438fea60 438fef40 : e2 e2 e2 e4 e8 ea eb eb e8 e7 e4 e3 e1 e3 e3 e4
4390fbd 438fea80 438fef60 : e6 e8 ea ed ee ea e6 e5 e3 e2 e0 e1 df e1 e7

```

Fig. 5-2

1.4.3 Placement of Scanner Unit in Position for Transportation (Function code 06)

<Function>

This function is to move the scanner unit in position for transportation located at the left end. When you fix the machine and check its operation, you need to perform this function last before packing and shipping.

Note:

Please instruct end users to perform this function if possible before packing and shipping their FAX machine to a sales agent or a service dealer for the purpose of repair. (For the procedure to allow users to perform maintenance modes, refer to “1.2 How to Enter the End User-accessible Maintenance Mode” in this chapter.

<Operating Procedure>

- (1) Press the **0** and **6** buttons in this order in the initial stage of the maintenance mode.
The scanner unit moves to the designated position for transportation located at the left end. The “MAINTENANCE 06” is displayed until the scanner unit is placed in position. When the scanner unit is placed in the position, the “SCAN LOCK” appears on the LCD.
- (2) Press the **Stop/Exit** button. The machine beeps for one second and returns to the initial stage of the maintenance mode.

Note:

- If it is impossible to move the scanner unit in position for transportation, or if this function is performed while a scanning error is occurring, the “SCAN LOCK ERROR” appears on the LCD.
- You can not perform the scanning operation such as copying after moving the scanner unit into the position for transportation.

1.4.4 ADF Performance Test (Function code 08)

<Function>

The machine counts the documents fed by the automatic document feeder (ADF) and displays the count on the LCD for checking of the ADF performance.

<Operating Procedure>

- (1) Set documents. (Allowable up to the ADF capacity.)
The “DOC. READY” will appear on the LCD.
- (2) Press the **0** and **8** buttons in this order.
While counting the documents, the machine feeds them in and out, displaying the current count on the LCD as shown below.

ADF CHECK P.01



Current count (1st page in this example)

- (3) Press the **Stop/Exit** button so that the machine beeps for one second and returns to the initial stage of the maintenance mode.

1.4.5 Test Pattern (Function code 09)

<Function>

This function prints out a test pattern (Print Quality Check sheet) to allow the service personnel to check the print quality.

<Operating Procedure>

- (1) Press the **0** and **9** buttons in this order in the initial stage of the maintenance mode.
- (2) The machine starts printing a test pattern. Upon completion of printing, the machine beeps for one second and returns to the initial stage of the maintenance mode.

The figure below shows a test pattern that is printed.

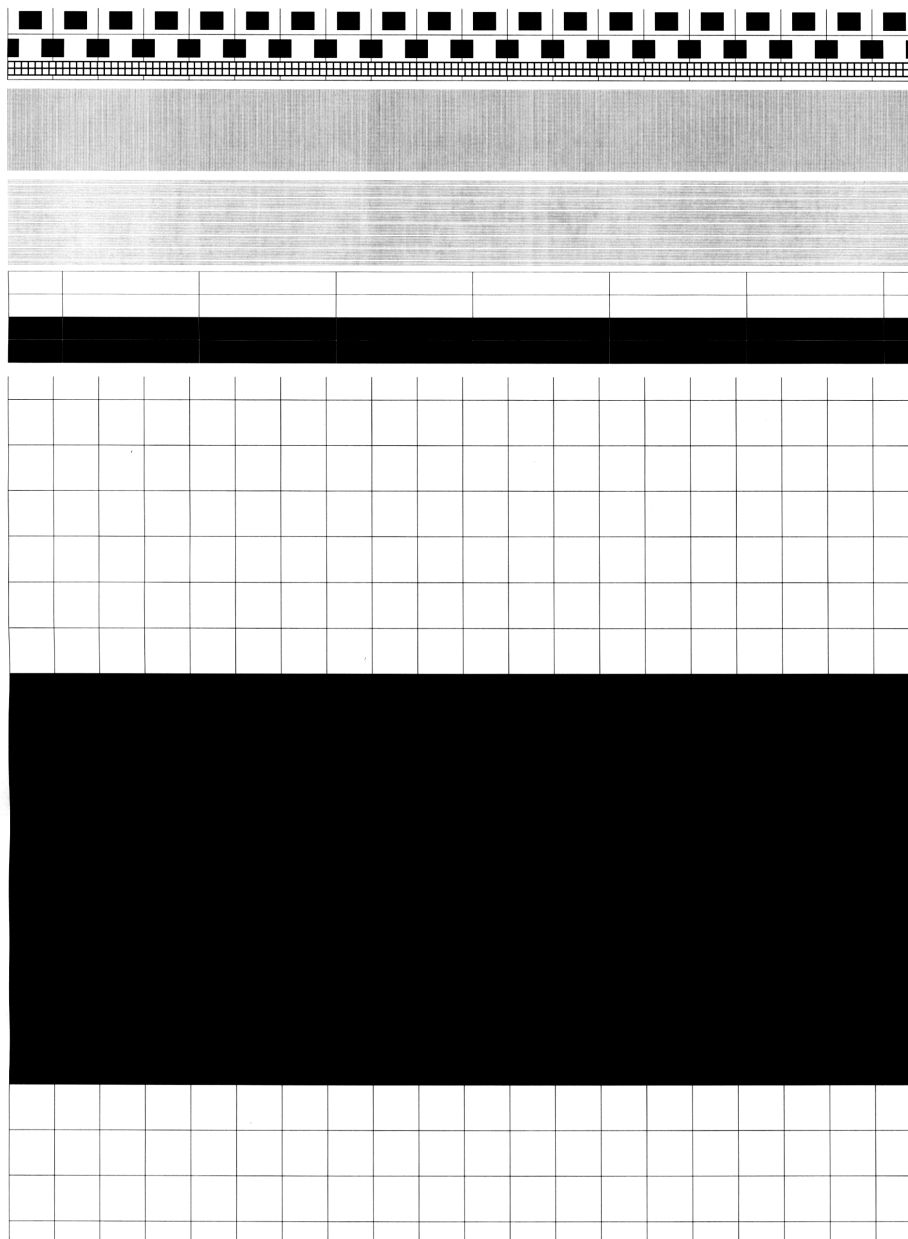

Fig. 5-3

1.4.6 Worker Switch (WSW) Setting and Printout

[1] Worker Switch Setting (Function code 10)

<Function>

The machine incorporates the following worker switch functions which may be activated with the procedures using the control panel buttons. The worker switches have been set at the factory in conformity to the communications standards and codes of each country. Do not disturb them unless necessary. Some worker switches may not be applicable in some versions. The worker switch data list indicates "Not used." for those inapplicable switches.

■ Worker Switches

WSW No.	Function	Refer to:
WSW01	Dial pulse setting	App. 1-3
WSW02	Tone signal setting	App. 1-5
WSW03	PABX mode setting	App. 1-6
WSW04	TRANSFER facility setting	App. 1-8
WSW05	1st dial tone and busy tone detection	App. 1-9
WSW06	Redial/Pause button setting and 2nd dial tone detection	App. 1-10
WSW07	Dial tone setting 1	App. 1-12
WSW08	Dial tone setting 2	App. 1-13
WSW09	Protocol definition 1	App. 1-14
WSW10	Protocol definition 2	App. 1-15
WSW11	Busy tone setting	App. 1-16
WSW12	Signal detection condition setting	App. 1-17
WSW13	Modem setting	App. 1-18
WSW14	AUTO ANS facility setting	App. 1-19
WSW15	REDIAL facility setting	App. 1-20
WSW16	Function setting 1	App. 1-21
WSW17	Function setting 2	App. 1-22
WSW18	Function setting 3	App. 1-23
WSW19	Transmission speed setting	App. 1-24
WSW20	Overseas communications mode setting	App. 1-25
WSW21	TAD setting 1	App. 1-26
WSW22	ECM and call waiting caller ID	App. 1-27
WSW23	Communications setting	App. 1-28
WSW24	TAD setting 2	App. 1-29
WSW25	TAD setting 3	App. 1-30
WSW26	Function setting 4	App. 1-31
WSW27	Function setting 5	App. 1-32
WSW28	Function setting 6	App. 1-33
WSW29	Function setting 7	App. 1-34
WSW30	Function setting 8	App. 1-35
WSW31	Function setting 9	App. 1-36
WSW32	Function setting 10	App. 1-37
WSW33	Function setting 11	App. 1-38
WSW34	Function setting 12	App. 1-39
WSW35	Function setting 13	App. 1-40
WSW36	Function setting 14	App. 1-40

WSW No.	Function	Refer to:
WSW37	Function setting 15	App. 1-42
WSW38	V.34 transmission settings	App. 1-43
WSW39	V.34 transmission speed	App. 1-44
WSW40	V.34 modem settings	App. 1-45
WSW41	ON-duration of the scanning light source	App. 1-47
WSW42	Internet mail settings	App. 1-48
WSW43	Function setting 21	App. 1-48
WSW44	Speeding up scanning-1	App. 1-49
WSW45	Speeding up scanning-2	App. 1-50
WSW46	Monitor of power ON/OFF state and parallel port kept at high	App. 1-51
WSW47	Switching between high- and full-speed USB	App. 1-52
WSW48	USB setup latency	App. 1-53
WSW49	End-of-copying beep and print in black	App. 1-54
WSW50	SDAA settings	App. 1-55
WSW51	Function setting 16	App. 1-56
WSW52	Function setting 17	App. 1-57
WSW53	Function setting 18	App. 1-58
WSW54	Function setting 19	App. 1-59
WSW55	Function setting 20	App. 1-60
WSW56	Function setting 21	App. 1-60
WSW57	Function setting 22	App. 1-61
WSW58	Function setting 23	App. 1-62
WSW59	Function setting 24	App. 1-62
WSW60	Not used.	App. 1-63
WSW61	Judgment of scanning light intensity stability 1	App. 1-63
WSW62	Judgment of scanning light intensity stability 2	App. 1-64

* Details of Worker switches

The details of the worker switches are described in [Appendix 1](#) in which the user-accessible selectors of the worker switches are shaded.

<Operating Procedure>

- (1) Press the **1** and **0** buttons in this order in the initial stage of the maintenance mode.
The machine displays the "WSW00" on the LCD and becomes ready to accept a worker switch number.
- (2) Enter the desired number from the worker switch numbers (01 through 59).
The following appears on the LCD:

Selector 1 Selector 8
 ↓ ↓
 WSWXX = 0 0 0 0 0 0 0 0

- (3) To Enter a value to be set (0 or 1) use the ◀ and ▶ buttons to move the cursor to the desired position and enter the **0** or **1** button to change.
- (4) Press the **OK** button. This operation saves the newly entered selector values onto the EEPROM and readies the machine for accepting a worker switch number.
- (5) Repeat steps (2) through (4) until the modification for the desired worker switches is completed.
- (6) Press the **Stop/Exit** button so that the machine beeps for one second and returns to the initial stage of the maintenance mode.

Note:

- To cancel this operation and return the machine to the initial stage of the maintenance mode during the above procedure, press the **Stop/Exit** button.
- If there is a pause of more than one minute after a single-digit number is entered for double-digit worker switch numbers, the machine will automatically return to the initial stage of the maintenance mode.

[2] Printout of Worker Switch Data (Function code 11)

<Function>

The machine prints out the setting items and contents specified by the worker switches.

<Operating Procedure>

- (1) Press the **1** button twice in the initial stage of the maintenance mode. The "PRINTING" will appear on the LCD.
- (2) The machine prints out the configuration list as shown in the figure below.
- (3) Upon completion of printing, the machine beeps for one second and returns to the initial stage of the maintenance mode.

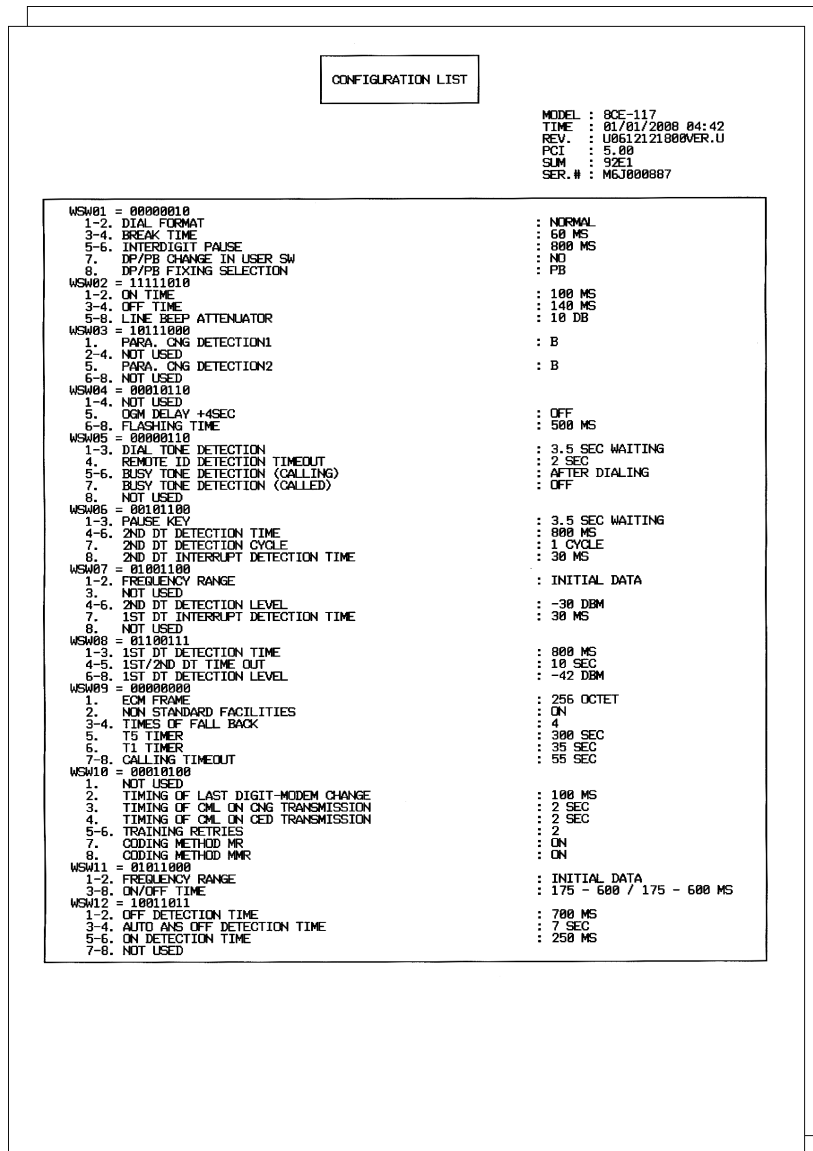

Fig. 5-4

1.4.7 Operational Check of LCD (Function code 12)

<Function>

This function allows you to check whether the LCD on the control panel works normally.

<Operating Procedure>

- (1) Press the **1** and **2** buttons in this order in the initial stage of the maintenance mode. The LCD shows.
- (2) Press the **Black Start** button. Each time you press the **Black Start** button, the LCD cycles through the displays shown below.
- (3) Press the **Stop/Exit** button in any process of the above display cycle. The machine beeps for one second and returns to the initial stage of the maintenance mode.

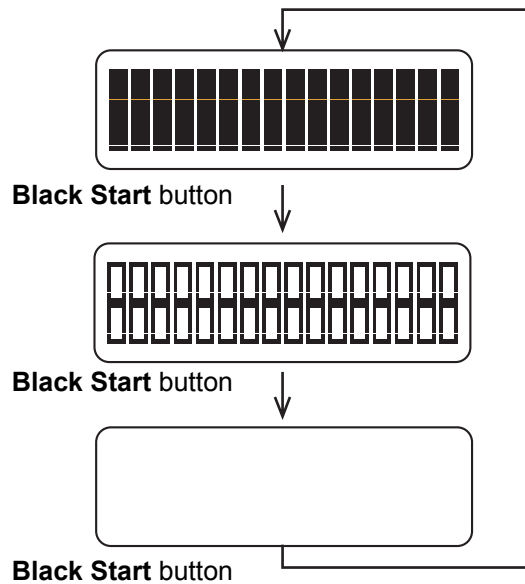

Fig. 5-5

1.4.8 Operational Check of Control Panel Button (Function code 13)

<Function>

This function allows you to check the control panel button for normal operation.

<Operating Procedure>

- (1) Press the **1** and **3** buttons in this order in the initial stage of the maintenance mode.
The machine displays "00" on the LCD.
- (2) Press the buttons in the order designated in the illustration shown below.
The LCD shows the corresponding number in decimal notation each time a button is pressed. Check that the displayed number is correct by referring to the illustration below.
If a button is pressed out of order, the machine displays the "INVALID OPERATE" on the LCD. To return to the status ready to accept button entry for operational check, press the **Stop/Exit** button.
- (3) After the last number button is pressed, the machine beeps for one second and returns to the initial stage of the maintenance mode.
To terminate this operation, press the **Stop/Exit** button. The machine beeps for one second and returns to the initial stage of the maintenance mode.

■ MFC-9440CN/ 9450CDN



Fig. 5-6

■ DCP-9040CN/ 9042CDN

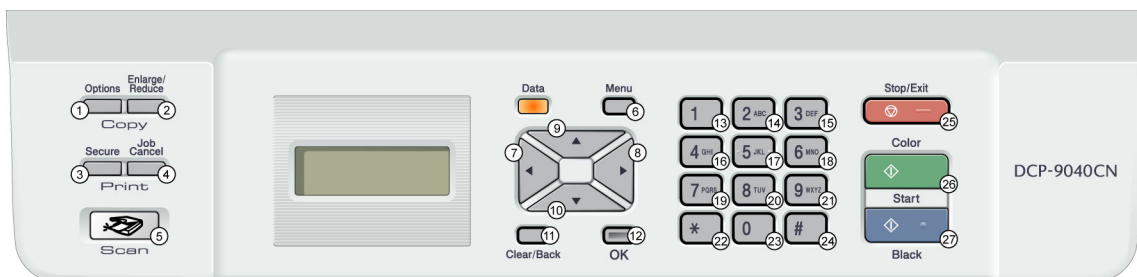

Fig. 5-7

1.4.9 ROM Version Check (Function code 25)

<Function>

This function allows you to check the management information of the software programs such as version information, check sum.

<Operating Procedure>

- (1) Press the **2** and **5** buttons in this order in the initial stage of the maintenance mode. The machine displays each of terms described below on the LCD.
- (2) Press the **▲** or **▼** button to check the next term.

LCD	Description
TOTAL: Ver A	Main firmware version information (Revision information)
PCL : Ver1.00*	Sub firmware (PCL/PS) version information (ROM size)
ENG : Ver1.01	Engine firmware version information
NET : Ver1.00	Network version information
PICT: Ver1.00	PictBridge version information
B0608071049:5708*	Boot program creation date & check sum information
U0612271600:7B0A*	Main firmware creation date & check sum information
P0612271602:BD40*	Sub firmware (PCL/PS) creation date & check sum information

- How to display the check sum information

Terms displayed with "*" have the check sum information as well. Press the **OK** button when its version information is displayed on the LCD. Press the **OK** button again to go back to the version information display. Press the **▲** or **▼** buttons to check the next term.

Note:

If you press the **OK** button when each version information of Engine, Network and PictBridge is displayed on the LCD, you cannot check the check sum information.

- (3) To terminate this operation, press the **Stop/Exit** button. The machine beeps for one second and returns to the initial stage of the maintenance mode.

1.4.10 Drum Unit Cleaning (Function code 31)

< Function >

This function allows you to remove the dust attached on the surface of the exposure drum by using the drum cleaning sheet.

< Operating Procedure >

- (1) Press the **3** and **1** buttons in this order in the initial stage of the maintenance mode. The "DRUM CLEANING" will appear on the LCD.
- (2) Load the drum cleaning sheet into the MP tray.
- (3) Press the **Black Start** button.
- (4) When the machine ejects the drum cleaning sheet and finishes cleaning the drum unit, "DRUM CLEANING / COMPLETED" appears on the LCD.
- (5) Press the **Stop/Exit** button to terminate this operation. Then, the machine beeps for one second and returns to the initial stage of the maintenance mode.

1.4.11 Operational Check of Sensors (Function code 32)

<Function>

This function allows you to check each of the sensors.

<Operating Procedure>

- Press the **3** and **2** buttons in this order in the initial stage of the maintenance mode. The machine beeps 1100 Hz and 400 Hz tones cycling through the following volumes for testing the speaker. To stop beeping, press the **OK** button.

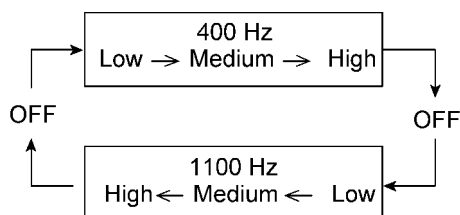

Fig. 5-8

If the sensing status are as listed below, the LCD will show “C1P1R1C2P2R2L2T2” when LT is installed. “C1P1R1*****” appears on the LCD when LT is not installed. The LCD indication moves to the next term by pressing the **Black Start** button.

Given below is the relationship between the LCD indication, sensor name and sensor status.

LCD	Sensors	Sensing status (ON/OFF)
C1	T1 sensor	Paper tray installed / not installed
P1	T1 PE sensor	Paper detected / not detected
R1	T1 edge sensor	Paper not detected / detected
C2	LT sensor	Paper tray installed / not installed
P2	LT PE sensor	Paper detected / not detected
R2	LT edge sensor	Paper not detected / detected
L2	LT plate-up detection sensor	Plate-up detected / not detected
T2	LT connector	LT connected / not connected
MR	MP registration front sensor	Paper detected / not detected
MP	MP PE sensor	Paper detected / not detected
CV	Front cover	Front cover closed / open
RC	Back cover	Back cover closed / open
RM	T1 registration front sensor	Paper not detected / detected
RA	Registration rear sensor	Paper not detected / detected
PO	Paper eject sensor	Paper not detected / detected
NK	Toner sensor K (NEW)	Toner cartridge (K) used / new
NY	Toner sensor Y (NEW)	Toner cartridge (Y) used / new
NM	Toner sensor M (NEW)	Toner cartridge (M) used / new
NC	Toner sensor C (NEW)	Toner cartridge (C) used / new
KC	Toner sensor K (TE)	Toner (K) detected / not detected
YC	Toner sensor Y (TE)	Toner (Y) detected / not detected
MC	Toner sensor M (TE)	Toner (M) detected / not detected
CC	Toner sensor C (TE)	Toner (C) detected / not detected

Note:

The machine makes a sound when operating the toner sensor K (NEW) and toner sensor Y (NEW) while the cover is opened.

LCD	Sensors	Sensing status (ON/OFF)
DV	Develop release sensor	Release / Welding
BC	Belt cleaner release sensor	Release / Contact
NW	Waste toner sensor 1	Toner not detected / nearly full
FW	Waste toner sensor 2	Toner not detected / full

LCD	Temperature and humidity sensors	Sensing status (OK / NG)
TMP	THM sensor	XX°C / NG
HUM	HUM sensor	XX% / NG
MAC	Internal temperature sensor	XX°C / NG
BT	Belt unit temperature sensor	XX°C / NG

Note:

If the sensor detects the abnormal value, the machine displays “NG” on the LCD.

LCD	Sensors	Sensing status (ON/OFF)
DF	Document front sensor	No document detected / detected.
DR	Document rear sensor	No document detected / detected.
DL*	ADF document separation sensor / Size sensor	Document detected / not detected
DS*	ADF document SB sensor	No document detected / detected.
FC*	FB cover sensor	Document cover closed / opened.
FH*	FB unit home position sensor	CCD unit home position detected / not detected

The LCD indication with * is not displayed for the CIS mode.

Note:

- The “--” appears on the LCD if the sensor is OFF.
- The “**” appears on the LCD if the parts are not installed or there is no term.

- (2) Change the detecting conditions to check that the indication on the LCD changes according to the sensor states. For instance, insert paper through the document front (or rear) sensor or the registration sensor (s), open the front cover or the document cover, remove the toner cartridge, jam paper at the paper outlet, insert paper from the manual feeder, and load a recording paper tray, etc.
- (3) Press the **Stop/Exit** button. The machine beeps for one second and returns to the initial stage of the maintenance mode.

■ Location of sensors

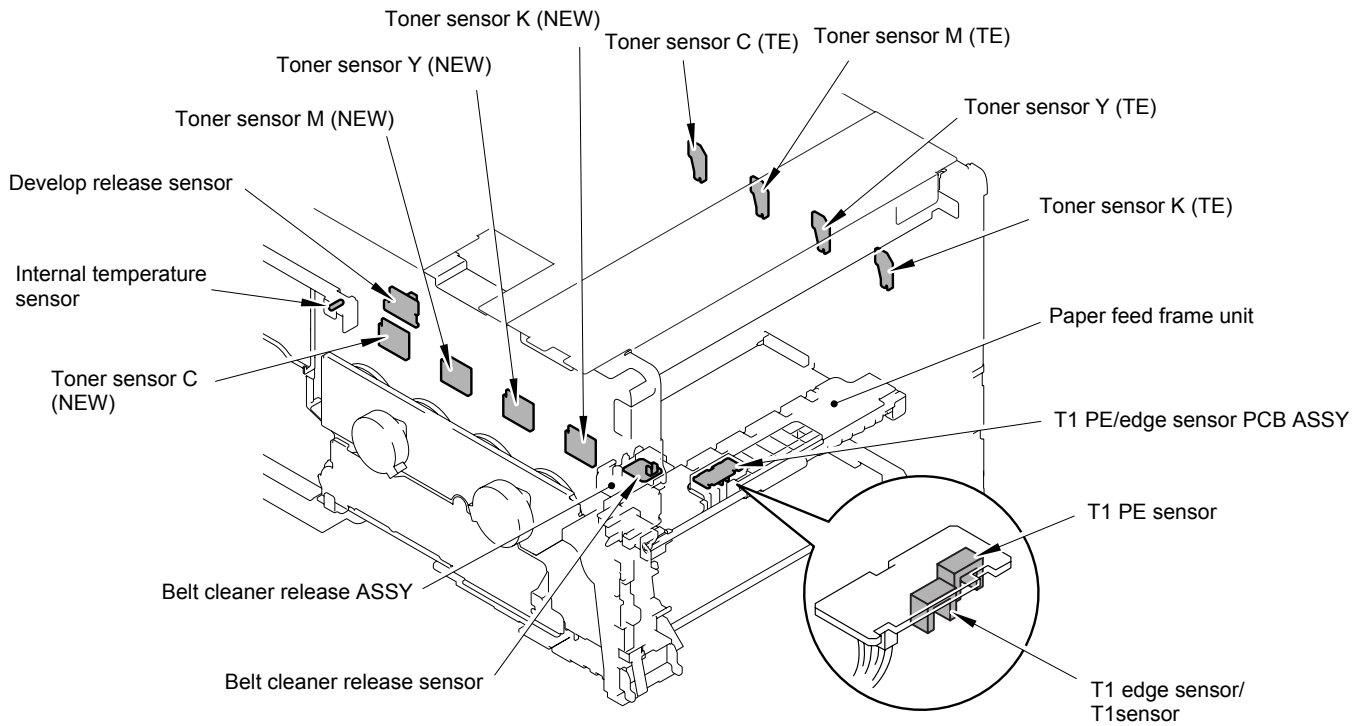

Fig. 5-9

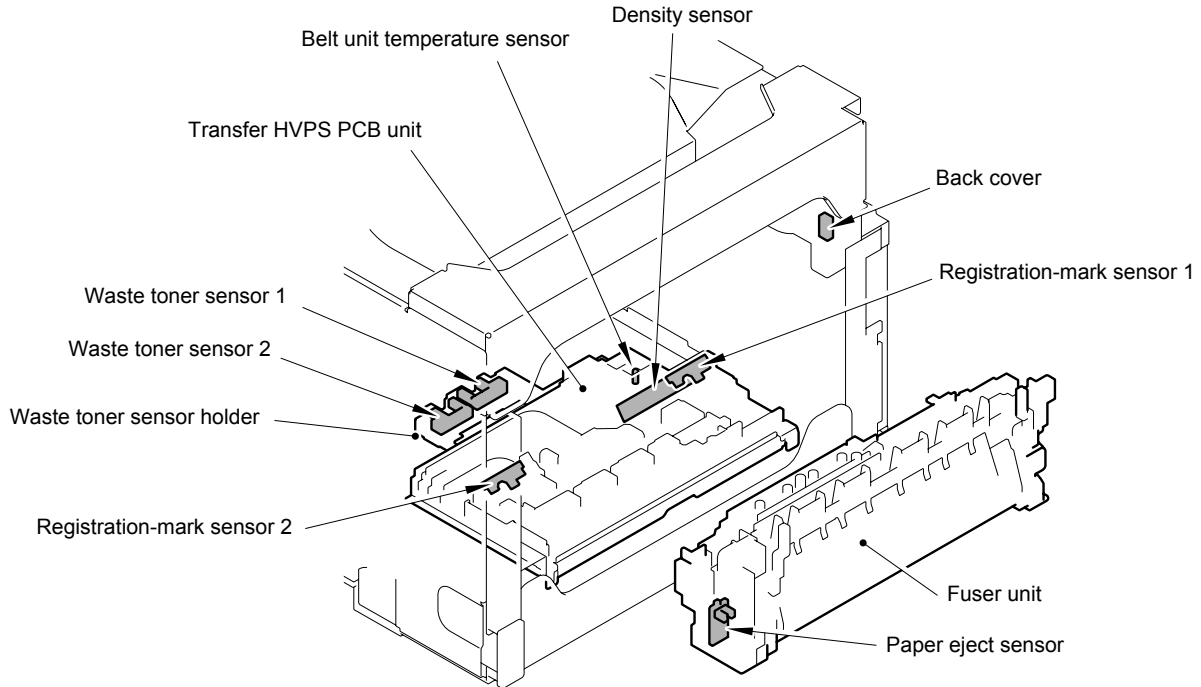

Fig. 5-10

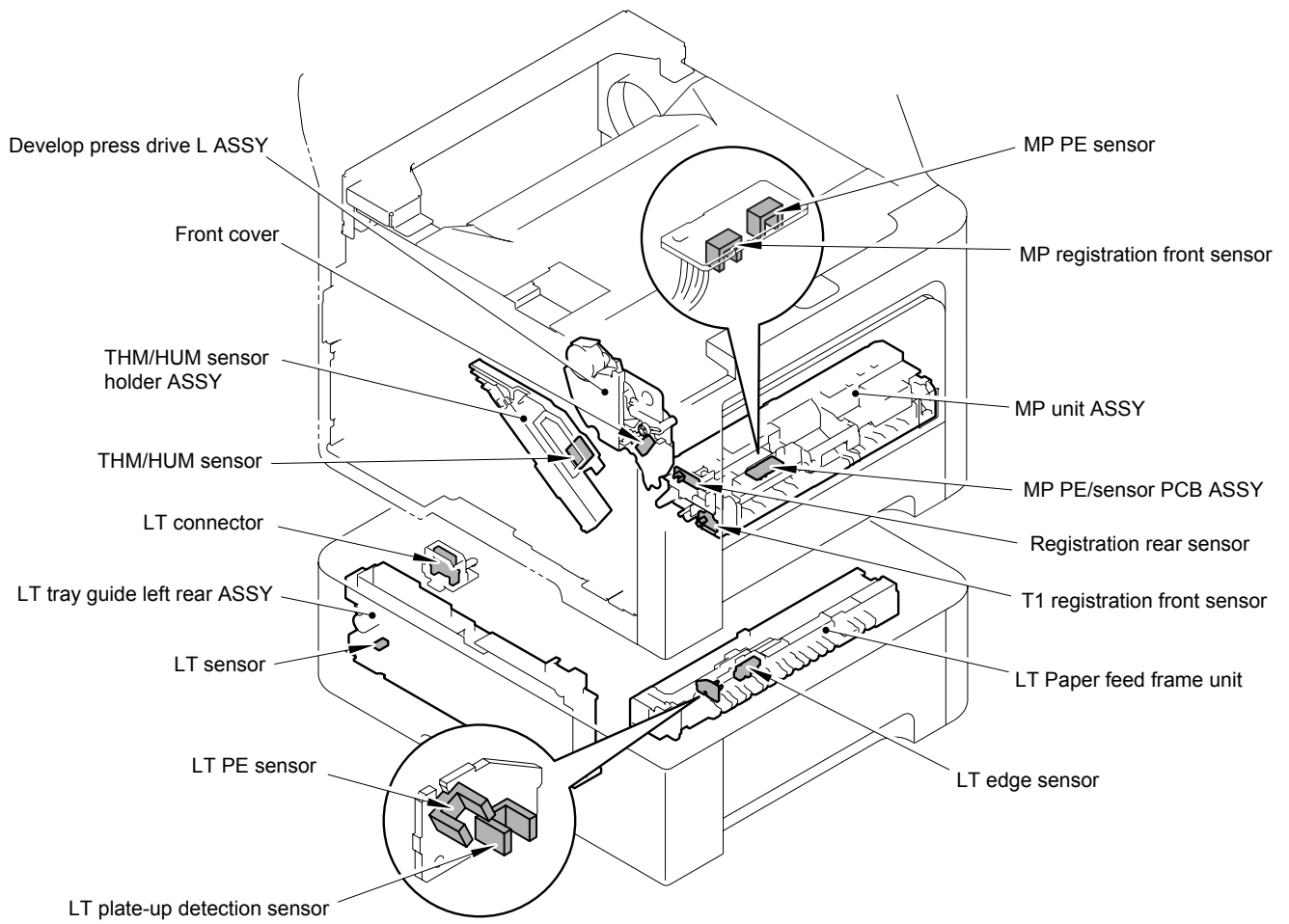

Fig. 5-11

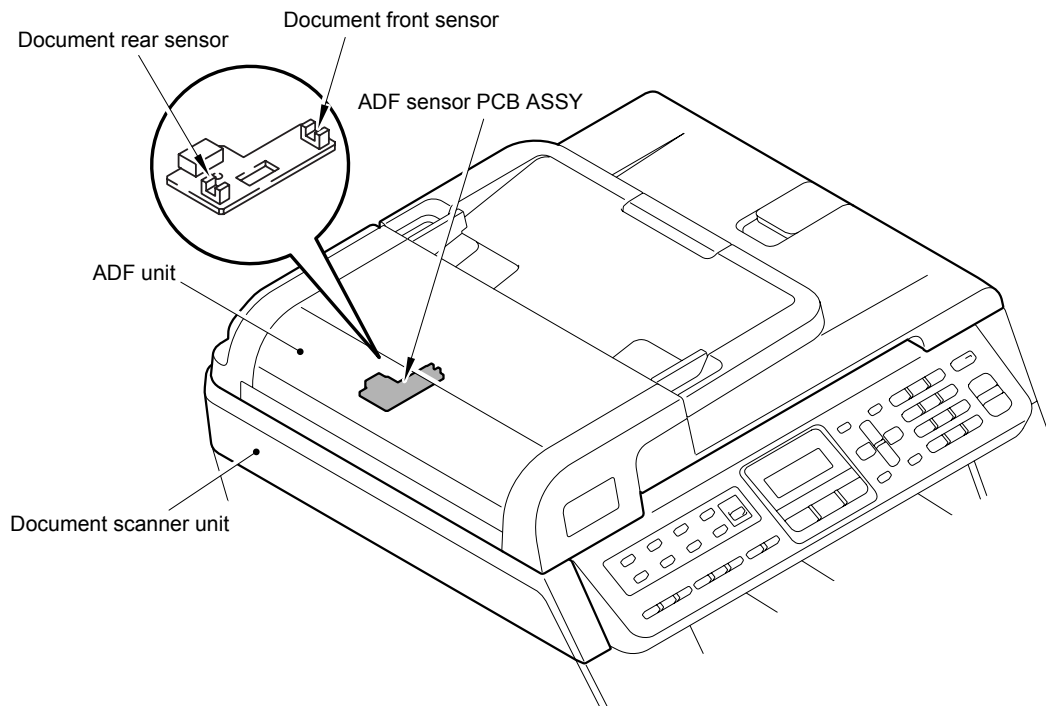

Fig. 5-12

1.4.12 Switching of the USB Transfer Speed in the PictBridge Mode (Function code 45)

<Function>

This function allows you to change the USB transfer speed in the PictBridge mode. If the digital camera which a user uses cannot be connected in the PictBridge mode, it may be possible by changing the speed setting.

- PB.Speed=AUTO: Sets the speed depending on the USB device performance. (Full Speed or High Speed)
- PB.Speed=FULL: Fixes the speed to Full Speed regardless of the USB device performance.

(An asterisk (*) appears beside the function to be currently set.)

<Operating Procedure>

- (1) Press the **4** and **5** buttons in this order in the initial stage of the maintenance mode. The "PB.USBspeed" will appear on the LCD.
- (2) Press the **OK** button. Press the **▲** or **▼** button to select the function you want to set and press the **OK** button. Then, the machine beeps for one second and returns to the initial stage of the maintenance mode.

Note:

The setting will be enabled after turning the power switch of the machine off and on.

1.4.13 EEPROM Customizing (User-accessible) (Function code 52)

<Function>

This function allows users to customize the EEPROM settings such as language, function settings or worker switch settings.

Note:

This function is applicable to “France and surrounding countries”, “Pan-Nordic”, “East Europe”, “Oceania” and “Iberia” areas only.

<Operating Procedure>

- (1) Press the **Menu**, **Black Start** and **Menu** buttons in this order in the ready state.
The “0” will appear on the LCD.
- (2) Press the **5** and **2** buttons in this order.
The “Set Country / Press OK” will appear on the LCD.
- (3) Press the **OK** button.
The country name will appear on the LCD.

Note:

The country name indicated on the LCD varies depending on the area (code input in [Function code 74](#)) as shown in the table below.

France and surrounding countries	Oceania	Pan-Nordic	Iberia	East Europe
France	Australia	Norge	España	österreich
België / Belgique	New Zealand	Suerige	Portugal	Ceska republika
Nederland		Suomi		Magyarország
		Danmark		Polska
		Others		България
				România
				Slovensko
				Others

- (4) Press the ▲ or ▼ button to display the country name where the machine is used. Press the **OK** button while the country name is being indicated.
The EEPROM is customized, and the machine returns to the ready state.

1.4.14 Received Data Transfer Function (Function code 53) (MFC-9440CN/ 9450CDN only)

<Function>

This function transfers received FAX data to another machine. It is useful when the machine cannot print received data due to the printing mechanism being defective. It also transfers the maintenance information of the machine via FAX.

Note:

The number of files that can be transferred at a time is 99. To transfer 100 files or more, carry out the following procedure more than one time.

TIP:

If there are both color and monochrome data in a file to be transferred, the monochrome data will be transferred first. If the receiver machine does not support the color function, the sender machine cannot transfer color data, resulting in an error.

<Operating Procedure>

- (1) Press the **5** and **3** buttons in this order in the initial stage of the maintenance mode.
The "FAX TRANSFER" appears on the LCD.
- (2) To check the number of received files, press the **1** button.
The "1.NO. OF JOBS" appears on the LCD.
Press the **OK** button, and the number of received files appears, just as "NO. OF. JOBS: 10."
- (3) To transfer the activity report only, press the **2** button.
The "2.ACTIVITY" appears.
To transfer received files (together with the activity report), press the **3** button.
The "3.DOCUMENTS" appears. Note that if there is no received file, the "NO DOCUMENTS" appears.
- (4) To transfer the communication list for the latest communication, press the **4** button.
The "4.COM.LIST (NEW)" appears.
To transfer the communication list for last three errors, press the **5** button.
The "5.COM.LIST (ERR3)" appears.
- (5) To transfer the maintenance information (the list in Function code 77), press the **6** button.
The "6.MNT77 LIST" appears on the LED.
- (6) With the "2.ACTIVITY," "3.DOCUMENTS," "4.COM.LIST (NEW)," "5.COM.LIST (ERR3)" or "6.MNT77 LIST" being displayed, press the **OK** button.
The "ENTER NO. & SET" appears.
- (7) Enter the telephone number of the receiver machine and press the **OK** button again.

Note:

Be sure to type the telephone number with the numerical buttons. No one-touch dialing is allowed in this procedure.

The machine displays the "ACCEPTED" for approx. two seconds and starts dialing to transfer data.

No station ID will be attached. A cover page and end page as shown on the next page will be automatically attached, instead.

■ Cover page sample

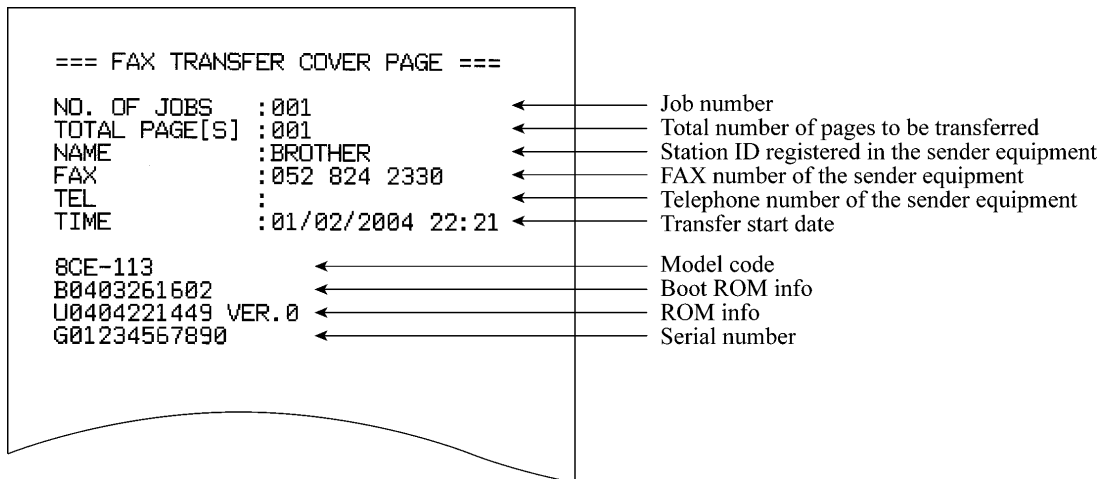

Fig. 5-13

■ End page sample

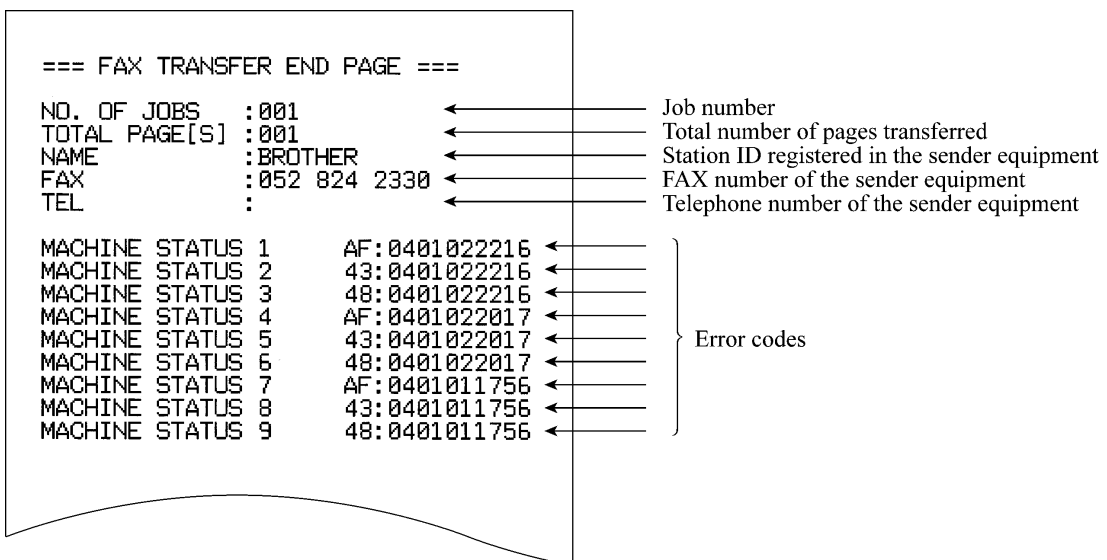

Fig. 5-14

1.4.15 Fine Adjustment of Scan Start/End Positions (Function code 54)

<Function>

This function allows you to adjust the scanning start and end positions with the ADF and FB unit.

<Operating Procedure>

- (1) Press the **5** and **4** buttons in this order in the initial stage of the maintenance mode. The "SCAN START ADJ." will appear on the LCD.
- (2) The "▲. ADF ▼. FB" will appear after two seconds. Select one of them that you want to adjust the start position. If you want to adjust the start position of the ADF, press ▲ button, and if you want to adjust that of the FB unit, press ▼ button.
- (3) Press the **1** or **2** button to display the present compensation level for the start position. Compensation levels can be adjusted in 11 steps from +5 to -5 (mm).
- (4) Press the ▲ button to increase compensation levels, and the ▼ button to lower them. Press the **Stop/Exit** button so that the machine beeps for one second and returns to the initial state of the maintenance mode without adjusting compensation levels.
- (5) Set the compensation level and press the **OK** button. The "ACCEPTED" will appear on the LCD. One second later, the machine "▲. ADF ▼. FB" will appear on the LCD.
- (6) Press the **Stop/Exit** button when finish the adjustment. The machine beeps for one second and returns to the initial state of the maintenance mode.

Note:

The correlation between the scan start/end positions and compensation levels is shown below.

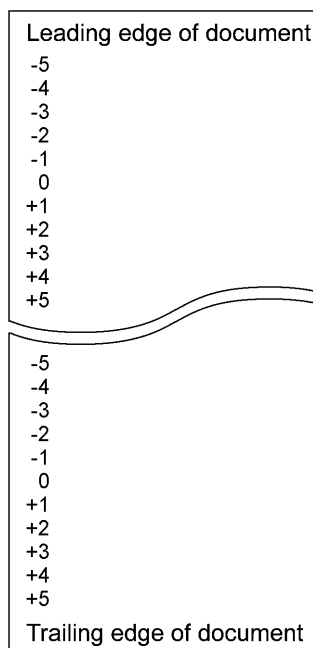

Fig. 5-15

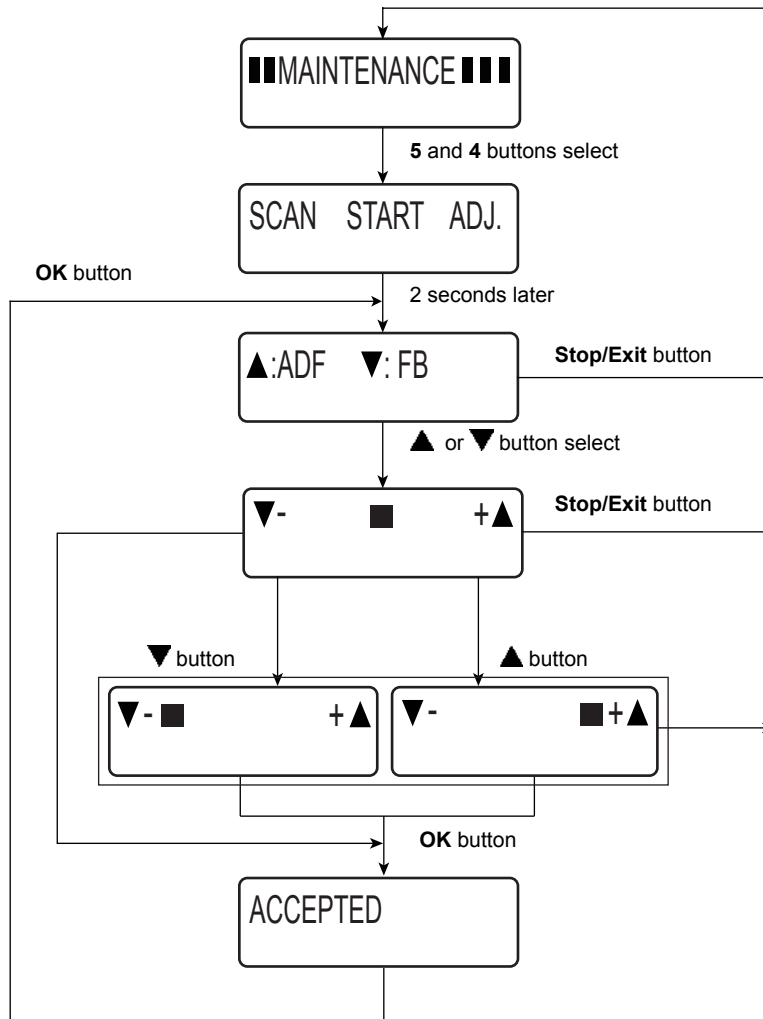

Fig. 5-16

1.4.16 Acquisition of White Level Data (Function code 55)

<Function>

This function allows the machine to obtain white level data for the scanner unit and save it into the EEPROM on the main PCB.

Note:

If you replace the scanner unit, be sure to carry out this procedure.

<Operating Procedure>

- (1) Press the **5** button twice in the initial stage of the maintenance mode.
The "SCANNER AREA SET" will appear on the LCD.
The machine saves the magnification compensation setting value into the EEPROM after a few seconds. Then, it beeps for one seconds and returns to the initial stage of the maintenance mode.

1.4.17 Adjustment of Color Registration (Function code 66)

<Function>

This function automatically adjusts color registration. If automatic adjustment of color registration fails, you can adjust color registration manually.

<Operating Procedure>

Automatic Adjustment of Color Registration

- (1) Press the **6** button twice in the initial stage of the maintenance mode.
"REGISTRATION" is displayed on the LCD.
- (2) Press the **OK** button.
"REGISTRATION/ PLEASE WAIT" is displayed on the LCD, and adjustment of color registration is automatically done.
- (3) When this operation is completed without an error, "REGISTRATION/ COMPLETED" is displayed on the LCD. When you press the **Stop/Exit** button, a buzzer sounds for approx. 1 sec, and the machine returns to the initial stage of the maintenance mode.

When an error message is displayed on the LCD, take the measures described in the table below.

Error message	Measure
REGISTRATION FAILED	Adjust color registration manually in accordance with the procedure for manual adjustment of color registration given below.
REGISTRATION TONER EMPTY <color>	Replace the empty toner cartridge, and then conduct the auto adjustment of color registration again.
NO PAPER LOAD <size> PAPER	Replenish paper of the size specified in the display on the tray, and then conduct the auto adjustment of color registration again.

* In the <color> field, the toner color of which cartridge becomes empty is displayed.

* In the <size> field, "LETTER" or "A4" is displayed. "LETTER" is displayed on the models of which default size is LETTER, and "A4" is displayed on the models of which default size is A4.

Manual Adjustment of Color Registration

- (1) Press the **6** button twice in the initial stage of the maintenance mode.
"REGISTRATION" is displayed on the LCD.
On the tray, load LETTER-size paper in the case of the models of which default size is LETTER, and A4-size paper in the case of the models of which default size is A4.
- (2) Press the **▲** or **▼** button to display "PRINT CHART" on the LCD, and then press the **OK** button.
- (3) Display "PRINT CHART/ PRINTING" on the LCD, and print the color registration adjustment chart ([next page](#)).
- (4) Press the **▲** or **▼** button to display "OFFSET ADJSUT" on the LCD, and then press the **OK** button. "1. M LEFT/ 0" is displayed on the LCD.
- (5) With the printed color registration adjustment chart, check the numeric value where the color is the darkest among the pattern 1 (Magenta Left). Press the **▲** or **▼** button to display that numeric value, and then press the **Black Start** button.

- (6) In the same way, enter the numeric value of the pattern 2, 3, 7, 8, and 9.
- (7) When you enter the numeric value of the pattern 9 (Yellow Right), "SET REGISTRATION/ COMPLETED" is displayed on the LCD. When you press the **Stop/Exit** button, a buzzer sounds for approx. 1 second and the machine returns to the initial stage of the maintenance mode.

■ Color registration adjustment chart

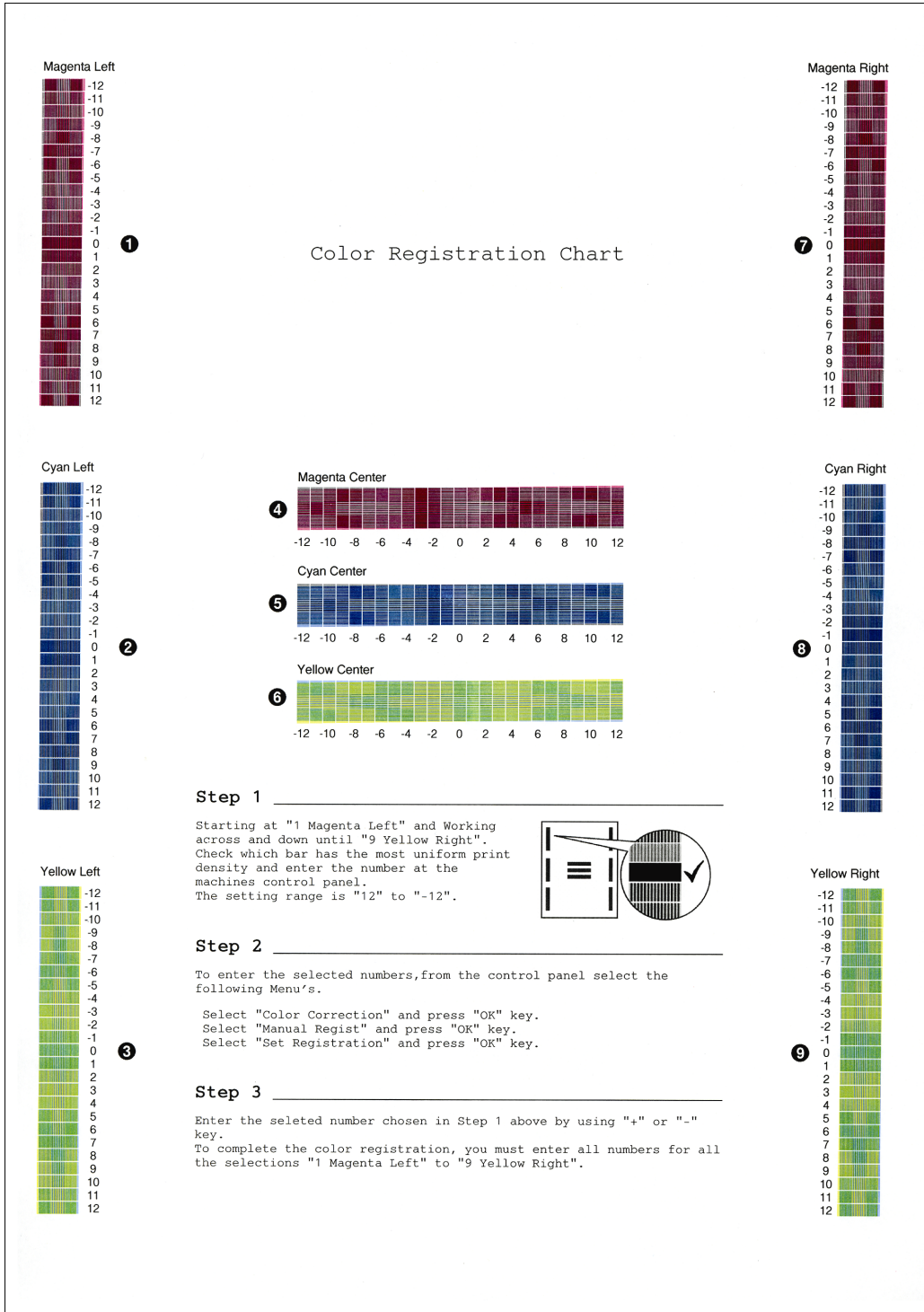

Fig. 5-17

1.4.18 Paper Feeding and Ejecting Test (Function code 67)

<Function>

This function allows you to check that a sheet of paper is fed and ejected correctly by printing the grid pattern on a page, whose interval is 1cm.

<Operating Procedure>

- (4) Press the **6** and **7** buttons in this order in the initial stage of the maintenance mode. The "SELECT: TRAY1" will appear on the LCD.
- (5) Press the ◀ or ▶ button to select the tray and mode to be performed a feeding test and press the **OK** button.

The testing terms are as follows;

LCD	Description
SELECT: TRAY1	Continuous one-side printing from Tray 1.
SELECT: TRAY2	Continuous one-side printing from Tray 2.
SELECT: MP	Continuous one-side printing from MP Tray.
SELECT: TRAY1 DX	Continuous two-sided printing from Tray 1.
SELECT: TRAY2 DX	Continuous two-sided printing from Tray 2.
SELECT: MP DX	Continuous two-sided printing from MP Tray.

- (6) The "PAPER FEED TEST" will appear on the LCD. The test printing is started, and the grid pattern is printed.
- (7) Press the **Stop/Exit** button so that machine stops printing. Then, it beeps for one second and returns to the initial stage of the maintenance mode.

Note:

In the case that the front cover is opened, or that there is no paper in the tray during test printing, the test printing is stopped.

1.4.19 Sensitivity Adjustment of Density Sensor (Function code 72) (Don't use)

<Function>

Although this function can be carried out, the machine does not adjust the sensitivity of the density sensor. Once the function is performed, the machine prints the patch data onto the belt unit. It may remain on the belt unit if the power switch is turned off before the performance is completed. Therefore, it is prohibited to use this function.

1.4.20 EEPROM Customizing (Function code 74)

<Function>

This function allows you to customize the EEPROM according to language, function settings, and worker switch settings.

Note:

If you replace the main PCB, be sure to carry out this procedure.

<Operating Procedure>

- (1) Press the **7** and **4** buttons in this order in the initial stage of the maintenance mode.
The current customizing code appears.
- (2) Enter the desired customizing code (e.g., 8101 in the case of MFC-9440CN U.S. model).
The newly entered code appears.
To enter letters "A" through "F", press the **1** through **6** buttons while holding down the **#** button respectively.

Note:

The machine does not work properly when an incorrect code is entered.

- (3) Press the **Black Start** button.
The machine saves the setting and displays the "PARAMETER INIT" on the LCD. The machine beeps for one second and returns to the initial stage of the maintenance mode.

If you press the **Stop/Exit** button or no buttons are pressed for one minute in the above procedure, the machine stops the procedure, beeps for one second and returns to the initial stage of the maintenance mode.
The modification of the setting data is not saved in this case.

<EEPROM customizing code list>

Destination	DCP-9040CN	DCP-9042CDN	MFC-9440CN	MFC-9450CDN
U.S.	0001	0201	8101	8301
Canada	0002	0202	0102	0302
Chile, Argentina	---	---	---	---
Brazil	---	---	0142	0342
Germany	1004	1204	0103	0303
UK	1004	1204	0104	0304
France	1005 (1055)	1205 (1255)	0105 (0155)	0305 (0355)
Norway	---	---	0107 (0157)	0307 (0357)
Belgium	1008 (1055)	1208 (1255)	0108 (0155)	0308 (0355)
Netherlands	1009 (1055)	1209 (1255)	0109 (0155)	0309 (0355)
Switzerland	1004	---	0110	0310
Finland	---	---	0112 (0157)	0312 (0357)
Denmark	---	---	0113 (0157)	0313 (0357)
Austria	---	---	0114 (0188)	0314 (0388)
Spain	1015 (1065)	1215 (1265)	0115 (0165)	0315 (0365)
Italy	1004	1204	0116	0316
Portugal	1018 (1065)	1218 (1265)	0118 (0165)	0318 (0365)
South Africa	---	---	0124	0324
Sweden	---	---	0126 (0157)	0326 (0357)
Slovakia	---	---	0130 (0188)	0330 (0388)
Bulgaria	---	---	0132 (0188)	0332 (0388)
Rumania	---	---	0133 (0188)	0333 (0388)
Czech	---	---	0137 (0188)	0337 (0388)
Hungary	---	---	0138 (0188)	0338 (0388)
Poland	---	---	0139 (0188)	0339 (0388)
Russia	1004	1204	0148	0348
Pan-Nor	1004	1204	---	---
General	(1004)	(1204)	0150 (0157)	0350 (0357)
EEU General	1004	(1204)	0150 (0188)	0350 (0388)
Singapore, Hong Kong, Gulf	0004	0204	0140	0340
Australia	---	---	0106 (0156)	0306 (0356)
New Zealand	---	---	0127 (0156)	0327 (0356)
China	0020	0220	0120	0320

* If you can determine the country where the customer uses the machine, enter the code outside the brackets. If not, enter the code inside.

1.4.21 Sensitivity Adjustment of Registration-mark Sensor (Function code 75)

<Function>

This function makes the registration-mark sensor to adjust its sensitivity compulsory. This function makes the machine to check the surface of the belt unit by using the registration-mark sensor as well.

	LCD	Description
1	REGI_SENS ADJUST BELT OFF	Adjust the sensitivity of the registration-mark sensor when the belt unit is not operated. This is to check whether the registration-mark sensor's operation is okay or not.
2	REGI_SENS ADJUST BELT ON	Adjust the sensitivity of the registration-mark sensor when the belt unit is operated. (This adjustment is the same as the operation before the color registration.)
3	REGI_SENS ADJUST BELT CHECK	Check whether there is no scratch on the surface of the belt unit within the detectable range of registration-mark sensor.

<Operating Procedure>

- (1) Press the **7** and **5** buttons in this order in the initial stage of the maintenance mode. "REGI SENS ADJUST" appears on the LCD.
- (2) Press the **▲** or **▼** button to select the appropriate term.
- (3) Press the **OK** button so that the selected operation is carried out.

Note:

- If you press the **OK** button during the sensitivity adjustment or after the error message appears on the LCD, the sensitivity adjustment is started again.
 - In the case that the error occurs, refer to the [next page](#) to check the error description and the way to solve it.
- (4) Upon completion of the above operation, the machine beeps for one second and returns to the initial stage of the maintenance mode.

< During the 1 or 3 adjustments >

Error Messages	Description	Solution
REGI_SENS ADJUST Write Err	Failure in writing the electron volume to NVRAM	Replace the engine PCB ASSY.
REGI_SENS ADJUST Belt Left Err	The measured data is abnormal when the sensitivity of the left registration-mark sensor is adjusted.	Replace the belt unit. If the belt unit is not replaced, set the auto color registration OFF and implement the manual color registration.
REGI_SENS ADJUST Belt Right Err	The measured data is abnormal when the sensitivity of the right registration-mark sensor is adjusted.	

< During the 2 adjustment >

LCD	Description	Solution
REGI_L_SENS: XXX REGI_R_SENS: OK	Check result of the surface of the belt unit within the detectable range of the left registration-mark sensor.	Replace the belt unit. If the belt unit is not replaced, set the auto color registration OFF and implement the manual color registration.
REGI_L_SENS: OK REGI_R_SENS: XXX	Check result of the surface of the belt unit within the detectable range of the right registration-mark sensor.	
REGI_L_SENS: XXX REGI_R_SENS: XXX	Check result of the surface of the belt unit within the detectable range of the left and right registration-mark sensors.	

* XXX describes the number of time (1~999) to detect the scratched on the surface of the belt unit. If the number of time is more, the condition of the belt unit is worse.

1.4.22 Printout of Maintenance Information (Function code 77)

<Function>

This function is to print out log information.

<Operating Procedure>

- (1) Press the **7** button twice in the initial state of the maintenance mode.
The "MAINTENANCE 77" will appear on the LCD.
- (2) The machine prints out a list of log information. Upon completion of printing, the machine returns to the initial state of the maintenance mode. The example of the log information is shown below.

■ Maintenance information

```

BCE-135                1004 BE
B0611021337           PCL:1.04  ENG:1.07
U0703141929 VER.W    1975      000C7005796
RTC                   OK        OK   01:56  23:33
WHQL                  01CB     A7J001729
55                    OK
  2018008000004000
  42B204000800080    00000F2
DRUM COUNT            00340928
AVG CDVERAGE C 0.04% M 0.86% Y 0.04% K 0.37%
TOTAL PRINTED TTL/CL/MN 0014305/0010328/0003977
COPY CNT TTL/CL/MN 0000236/0000093/0000143
PRINT CNT TTL/CL/MN 0014065/0010235/0003830
LIST/FAX CNT TTL/CL/MN 0000004/0000000/0000004
IMAGES C/M/Y/K 0009126/0009144/0009941/0013705
TOTAL PAGES PICKUP
T1/T2/MP/DX 0010050/0000000/0002541/0001714
A4+LTR/LGL+A4LONG 0011527/0000060
B5+EXE/ENVELOPE 0000010/0000009
A5/OTHER 0000909/0000076
TOTAL PAPER JAMS 0000037
T1/T2/MP 0000008/0000000/0000002
INSIDE/REAR/DX 0000018/0000006/0000003
DRUM CNG CNT/DATE 0000 00/00/00
DRUM PAGE COUNT 0014305
TONER      CYAN      MAGENTA  YELLOW  BLACK
CNG CNT  0003      0003      0002      0003
CNG DATE 08/01/01 08/01/04 08/01/02 08/01/01
PAGE CNT1 004838  000279  005235  001048
PAGE CNT2 000858  005029  003460  006433
DEVELOPING BIAS C/M/Y/K C321V M413V Y420V K450V
MAC ERROR 1/2      80:0801020050/61:0801040107
           3/4      61:0801040103/61:0801040059
           5/6      7D:0801030720/7D:0801030719
           7/8      57:0801030652/63:0801010732
           9/10     63:0801010730/88:0801010001
ADF JAM CNT SX/DX 0000007/0000005
ADFSX/ADFDX/FB PAGE CNT 0000401/0000807/0001856
COM ERROR 1      00000000:0401010000
           2      00000000:0401010000
           3      00000000:0401010000
KO:000000/000000 MN:000000/000000
RS:000000/000000 EJ:000000/000000

```

Fig. 5-18

1.4.23 Operational Check of Fans (Function code 78)

<Function>

This function is to check whether each of fans is operating correctly or not. The following fans are checked.

LCD	Parts Name	Description
FU	Fuser unit fan	Evacuate hot air of the fuser unit.
OPC	Drum unit fan	Evacuate hot air of the drum unit drive motor.
PS	LVPS fan	Evacuate hot air of the LVPS unit.
AIR	Air intake fan	Intake air to prevent a dirt on the corona wire.

<Operating Procedure>

- (1) Press the **7** and **8** buttons in this order in the initial stage of the maintenance mode. The indication will appear on the LCD as shown in the figure below.

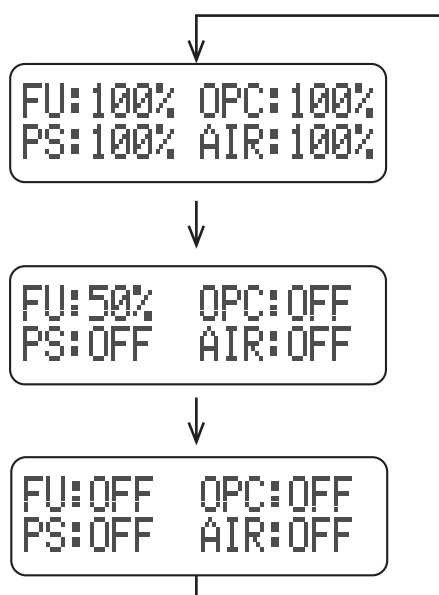

Fig. 5-19

- (2) Press the **Black Start** button so that the LCD indication is changed in the order shown in the figure above. The fan operation is also changed as indicated on the LCD.
- (3) Press the **Stop/Exit** button so that the machine stops checking the fans, beeps for one second and returns to the initial stage of the maintenance mode.

Note:

If the air intake fan (AIR) error occurs, the following error message appears on the LCD.

If you press the **Stop/Exit** button, the machine returns to the initial stage of the maintenance mode without recovering from this error. To recover from this error, turn the power switch of the machine off and then turn it on again.

Machine Error 2B

Fig. 5-20

■ Location of fans

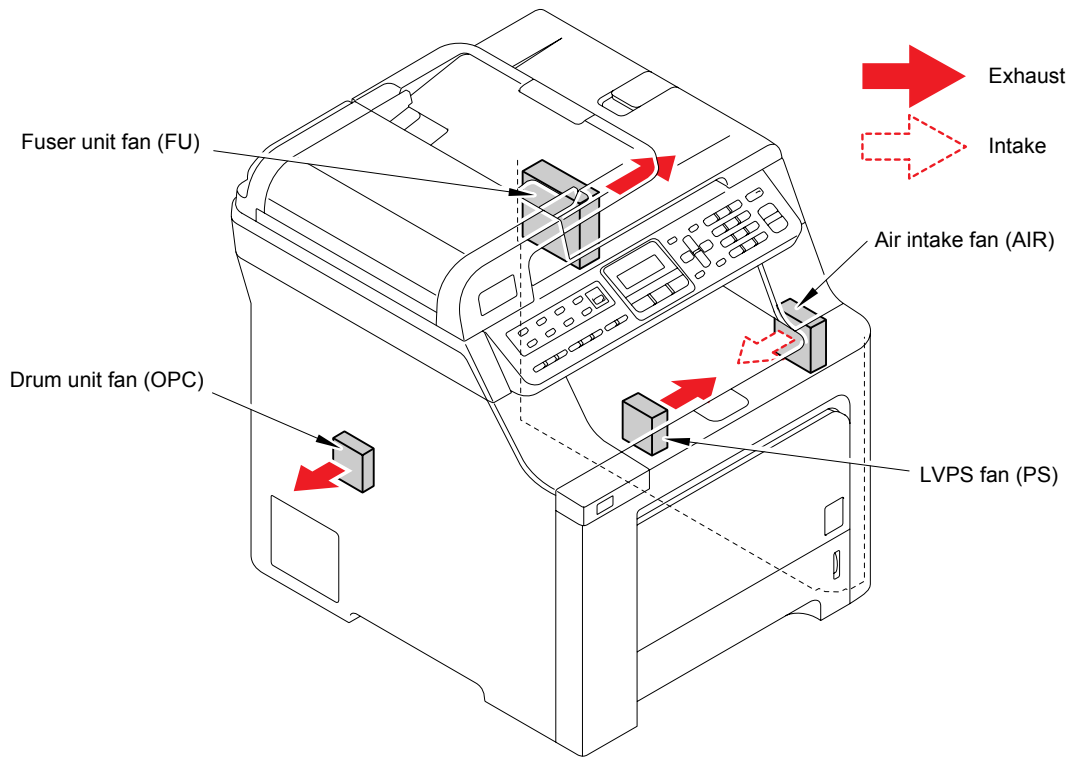

Fig. 5-21

1.4.24 Display of the Machine's Log Information (Function code 80)

<Function>

The machine may display its log information on the LCD.

<Operating Procedure>

- (1) Press the **8** and **0** buttons in this order in the initial stage of the maintenance mode. The USB serial number appears on the LCD.
- (2) Press the **Black Start** button. Each time the **Black Start** button is pressed, one of the following log information items appears on the LCD in the order. The representative items are given below.
- (3) Press the **Stop/Exit** button so that the machine stops this operation, beeps for one second and returns to the initial stage of the maintenance mode.

Note:

If the **OK** button is pressed when the "MACHINE ERR" or "COMEER1" appears on the LCD, the date and time when the error occurs are indicated on the LCD.

USB:	Serial number
DRUM:	Drum count
CCOVERAGE: *1	Average Cyan Coverage (%)
MCOVERAGE: *1	Average Magenta Coverage (%)
YCOVERAGE: *1	Average Yellow Coverage (%)
KCOVERAGE: *1	Average Black Coverage (%)
TTL_PG:	Total number of printed pages
TTL_CO:	Total number of color printed pages
TTL_MO:	Total number of monochrome printed pages
TTL_CI:	Cyan total number of printed pages
TTL_MI:	Magenta total number of printed pages
TTL_YI:	Yellow total number of printed pages
TTL_KI:	Black total number of printed pages
TTLCOPY	Number of copies made
CL_COPY	Number of color copies made
MN_COPY	Number of monochrome copies made
TTLPCPT	Number of PC prints made
CL_PCPT	Number of color PC prints made
MN_PCPT	Number of monochrome PC prints made
TTLLIST	Number of printed pages for the list or test pattern
CL_LIST	Number of color printed pages for the list or test pattern
MN_LIST	Number of monochrome printed pages for the list or test pattern
TTLFAX*2	Number of FAX outputs made
CL_FAX*2	Number of color FAX outputs made
MN_FAX*2	Number of monochrome FAX outputs made
TR1_PG	Number of pages picked up from the T1.
TR2_PG	Number of pages picked up from the LT.
MP_PG	Number of pages picked up from the MP.
A4+LTR	Number of A4/Letter size sheets picked up.
LG+A4L	Number of LEGAL/A4 LONG size sheets picked up.
B5+EXE	Number of B5/Executive size sheets picked up.
ENVLOP	Number of envelopes picked up.
A5	Number of A5 size sheets picked up.
OTHER	Number of other-size sheets picked up.

CTN_CH	Number of times the Cyan toner cartridge has been replaced.
CTN_PG1	Number of printed pages with the Cyan toner cartridge.
CTN_PG2	Number of times the Cyan toner cartridge has been replaced.
MTN_CH	Number of times the Magenta toner cartridge has been replaced.
MTN_PG1	Number of printed pages with the Magenta toner cartridge.
MTN_PG2	Number of times the Magenta toner cartridge has been replaced.
YTN_CH	Number of times the Yellow toner cartridge has been replaced.
YTN_PG1	Number of printed pages with the Yellow toner cartridge.
YTN_PG2	Number of times the Yellow toner cartridge has been replaced.
KTN_CH	Number of times the Black toner cartridge has been replaced.
KTN_PG1	Number of printed pages with the Black toner cartridge.
KTN_PG2	Previous number of printed pages with the Black toner cartridge.
WTNR_CH	Number of times the waste toner box has been replaced.
WTNR_PG ^{*3}	Number of printed pages with the waste toner box.
DRUM_CH	Number of times the drum unit has been replaced.
DRUM_PG ^{*3}	Number of printed pages with the drum unit.
BELT_CH	Number of times the belt unit has been replaced.
BELT_PG ^{*3}	Number of printed pages with the belt unit.
PFMP_CH	Number of times the MP paper feeding kit has been replaced.
PFMP_PG ^{*3}	Number of times the MP paper feeding kit has been replaced.
PFK1_CH	Number of times the T1 paper feeding kit has been replaced.
PFK1_PG ^{*3}	Number of times the T1 paper feeding kit has been replaced.
PFK2_CH	Number of times the LT paper feeding kit has been replaced.
PFK2_PG ^{*3}	Number of printed pages with the LT paper feeding kit.
FUSR_CH	Number of times the fuser unit has been replaced.
FUSR_PG ^{*3}	Number of printed pages with the fuser unit.
LASR_CH	Number of times the laser unit has been replaced.
LASR_PG ^{*3}	Number of printed pages with the laser unit.
ADSX_PG	Number of pages scanned with the ADF. (Simplex scanning)
FB_PG	Number of pages scanned with the FB unit.
CDEV_BIAS ^{*3}	Cyan developing bias voltage
MDEV_BIAS ^{*3}	Magenta developing bias voltage
YDEV_BIAS ^{*3}	Yellow developing bias voltage
KDEV_BIAS ^{*3}	Black developing bias voltage
TTL_JAM	Total number of jams
TR1_JAM	Number of jams that occurred at the T1.
TR2_JAM	Number of jams that occurred at the LT.
MP_JAM	Number of jams that occurred at the MP.
DX_JAM ^{*4}	Number of jams that occurred at the DX.
IN_JAM	Number of jams that occurred inside the machine.
RE_JAM	Number of jams that occurred at the ejecting.
ADSX_J	Number of jams occurred in simplex scanning with the ADF.
MACHINE_ERR_01 to 10	Last machine error code 01 to 10
COMERR1 to 3	Last communication error code 1 to 3

*1: Some margin of error must be taken into consideration because coverage for the printable area of A4-size paper is calculated using video signals.

*2: Not indicated for the DCP-9040CN/ 9042CDN model.

*3: The log information can be reset when pressing the **2**, **7**, **8** and **3** buttons while the information is being indicated.

*4: Not indicated for the DCP-9040CN/ MFC-9440CN model.

1.4.25 Error Code Indication (Function code 82)

<Function>

This function displays an error code of the machine on the LCD.

<Operating Procedure>

- (1) Press the **8** and **2** buttons in this order in the initial stage of the maintenance mode. The machine displays "MACHINE ERROR X X" on the LCD. (Refer to "2. ERROR CODES" in Chapter 1.)
- (2) Press the **Stop/Exit** button. The machine beeps for one second and returns to the initial stage of the maintenance mode.

1.4.26 Developing Bias Voltage Correction (Function code 83)

<Function>

The developing bias voltage correction is performed.

<Operating Procedure>

- (1) Press the **8** and **3** buttons in this order in the initial stage of the maintenance mode. The machine displays "Calibrate / Please Wait" on the LCD and starts the developing bias voltage correction.
- (2) Upon completion of the developing bias voltage correction, the machine beeps for one second and returns to the initial stage of the maintenance mode.

Note:

- Ignore all of the panel operation during the developing bias voltage correction.
- If an error occurs during the developing bias voltage correction, the following error message appears. Press the **OK** button to clear the error, and then the machine returns to the initial stage of the maintenance mode.

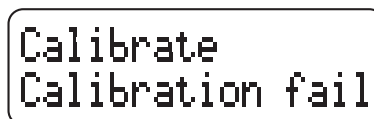

Fig. 5-22

- If an error - except for the developing bias voltage correction - such as "Cover is Open" occurs, follow the messages on the LCD to clear the error. If you clear the error, the machine returns to the initial stage of the maintenance mode. Again, start from the beginning to perform the developing bias voltage correction.

1.4.27 Output of Transmission Log to the Telephone Line (Function code 87)

<Function>

This function outputs the transmission log (that the machine has stored about the latest transmission) to the telephone line. It allows the service personnel to receive the transmission log of the user's machine at a remote location and use it for analyzing problems arising in the user's machine.

<Operating Procedure>

- (1) If the user's machine has a transmission-related problem, call the user's machine at a remote location from your machine.
- (2) If the line is connected, have the user perform the following:
 - 1) Hook up to the external phone.
 - 2) Press the **Menu**, **Black Start**, **Menu** buttons in this order.
 - 3) Press the **8** and **7** buttons.
The above operation makes the user's machine send CNG to your machine for sending the transmission log.
- (3) If you hear the CNG sent from the user's machine, press the **Black Start** button of your machine.
Your machine will start to receive the transmission log from the user's machine.

1.4.28 Exit from the Maintenance Mode (Function code 99)

<Function>

Exit from the Maintenance Mode.

<Operating Procedure>

- (1) Press the **9** button twice in the initial stage of the maintenance mode.
- (2) The machine exits from the maintenance mode and returns to the ready state.

2. OTHER SERVICE FUNCTIONS

2.1 Resetting the Periodical Replacement Parts Life

2.1.1 Resetting the Life Counter of the Belt Unit

<Function>

This function allows you to reset the page counter of the belt unit and increase the number of replacement times by one.

<Operating Procedure>

- (1) Press the **3** and **9** buttons at the same time in the ready state.
The "Reset Menu / Drum" will appear on the LCD.
- (2) Press the **▲** button a few times to select "Belt unit".
- (3) Press the **OK** button.
The "Belt unit / 1. Reset 2. Exit" will appear on the LCD.
- (4) Press the **1** button when resetting the page counter of the belt unit. Press the **2** button if not resetting.
- (5) The "Belt unit / Accepted" will appear on the LCD if pressing the **1** button. The page counter of the belt unit is reset, and the number of replacement times is increased by one. Then, the machine returns to the ready state.
If pressing the **2** button, the machine returns to the Belt unit and you need to press **Stop/Exit** button to go back to the ready state without performing any operation.

2.1.2 Resetting the Life Counter of the Fuser Unit

<Function>

This function allows you to reset the page counter of the fuser unit and increase the number of replacement times by one.

<Operating Procedure>

- (1) Press the **3** and **9** buttons at the same time in the ready state.
The "Reset Menu / Drum" will appear on the LCD.
- (2) Press the **▲** button a few times to select "Fuser".
- (3) Press the **OK** button.
The "Fuser / 1. Reset 2. Exit" will appear on the LCD.
- (4) Press the **1** button when resetting the page counter of the fuser unit. Press the **2** button if not resetting.
- (5) The "Fuser / Accepted" will appear on the LCD if pressing the **1** button. The page counter of the fuser unit is reset, and the number of replacement times is increased by one. Then, the machine returns to the ready state.
If pressing the **2** button, the machine returns to the Fuser and you need to press **Stop/Exit** button to go back to the ready state without performing any operation.

2.1.3 Resetting the Life Counter of the Drum Unit

<Function>

This function allows you to reset the page counter of the drum unit and increase the number of replacement times by one.

<Operating Procedure>

- (1) Press the **3** and **9** buttons at the same time in the ready state.
The "Reset Menu / Drum" will appear on the LCD.
- (2) Press the **OK** button.
The "Drum unit / 1. Reset 2. Exit" will appear on the LCD.
- (3) Press the **1** button when resetting the page counter of the drum unit. Press the **2** button if not resetting.
- (4) The "Drum unit / Accepted" will appear on the LCD if pressing the **1** button. The page counter of the drum unit is reset, and the number of replacement times is increased by one. Then, the machine returns to the ready state.
If pressing the **2** button, the machine returns to the Drum unit and you need to press **Stop/Exit** button to go back to the ready state without performing any operation.

2.1.4 Resetting the Life counter of the Paper Feeding Kit

<Function>

This function allows you to reset the page counter of the paper feeding kit and increase the number of replacement times by one.

<Operating Procedure>

- (1) Press the **3** and **9** buttons at the same time in the ready state.
The "Reset Menu / Drum" will appear on the LCD.
- (2) Press the **▲** button a few times to select "PF kit 1".
- (3) Press the **OK** button.
The "PF kit 1 / 1. Reset 2. Exit" will appear on the LCD.
- (4) Press the **1** button when resetting the page counter of the paper feeding kit. Press the **2** button if not resetting.
- (5) The "PF kit 1 / Accepted" will appear on the LCD if pressing the **1** button. The page counter of the paper feeding kit is reset, and the number of replacement times is increased by one. Then, the machine returns to the ready state.
If pressing the **2** button, the machine returns to the PF kit 1 and you need to press **Stop/Exit** button to go back to the ready state without performing any operation.

2.1.5 Resetting the Life Counter of the MP Paper Feeding Kit

<Function>

This function allows you to reset the page counter of the MP paper feeding kit and increase the number of replacement times by one.

<Operating Procedure>

- (1) Press the **3** and **9** buttons at the same time in the ready state.
The "Reset Menu / Drum" will appear on the LCD.
- (2) Press the **▲** button a few times to select "PF kit MP".
- (3) Press the **OK** button.
The "PF kit MP / 1. Reset 2. Exit" will appear on the LCD.
- (4) Press the **1** button when resetting the page counter of the MP paper feeding kit. Press the **2** button if not resetting.
- (5) The "PF kit MP / Accepted" will appear on the LCD if pressing the **1** button. The page counter of the MP paper feeding kit is reset, and the number of replacement times is increased by one. Then, the machine returns to the ready state.
If pressing the **2** button, the machine returns to the PF kit MP and you need to press **Stop/Exit** button to go back to the ready state without performing any operation.

2.1.6 Resetting the Life Counter of the Laser Unit

<Function>

This function allows you to reset the page counter of the laser unit and increase the number of replacement times by one.

<Operating Procedure>

- (1) Press the **3** and **9** buttons at the same time in the ready state.
The "Reset Menu / Drum" will appear on the LCD.
- (2) Press the **▲** button a few times to select "Laser".
- (3) Press the **OK** button.
The "Laser / 1. Reset 2. Exit" will appear on the LCD.
- (4) Press the **1** button when resetting the page counter of the laser unit. Press the **2** button if not resetting.
- (5) The "Laser / Accepted" will appear on the LCD if pressing the **1** button. The page counter of the laser unit is reset, and the number of replacement times is increased by one. Then, the machine returns to the ready state.
If pressing the **2** button, the machine returns to the Laser and you need to press **Stop/Exit** button to go back to the ready state without performing any operation.

2.2 Develop Roller/ Developing Bias Voltage Counter Reset Function

Since print density is likely to become darker as the toner gets older, the developing bias is lowered by degrees (bias voltage is reduced) according to the number of develop roller rotations so that an almost fixed density can be maintained from the beginning to the end. The developing bias voltage can be verified in the display of log information (Function code 80).

In the case that the toner cartridge is replaced with a new one, the develop roller counter and developing bias voltage are reset at the same time. This function allows you to reset these manually.

Panel Operation	Function
Pressing the Clear/Back button while the front cover is being opened.	Menus of the develop roller counter reset

<Operating Procedure>

Cover is Open
Close the Front



Reset Menu
B.TNR-S



B.TNR-S
1.Reset 2.Exit



B.TNR-S
Accepted



Cover is Open
Close the Front

- (1) Press the **Clear/Back** button while the front cover is being opened.
- (2) The "Reset Menu" appears on the LCD. Press the ▲ or ▼ buttons to select the appropriate toner cartridge, and then press the **OK** button.

LCD	Description
B.TNR-S	Reset the develop roller counter of standard black toner cartridge.
B.TNR-H	Reset the develop roller counter of high-capacity black toner cartridge.
C.TNR-S	Reset the develop roller counter of standard cyan toner cartridge.
C.TNR-H	Reset the develop roller counter of high-capacity cyan toner cartridge.
M.TNR-S	Reset the develop roller counter of standard magenta toner cartridge.
M.TNR-H	Reset the develop roller counter of high-capacity magenta toner cartridge.
Y.TNR-S	Reset the develop roller counter of standard yellow toner cartridge.
Y.TNR-H	Reset the develop roller counter of high-capacity yellow toner cartridge.

- (3) The "B.TNR-S / 1. Reset 2. Exit" will appear on the LCD. If resetting the counter, press the **1** button. If not, press the **2** button.
- (4) The counter is reset when pressing the **1** button.
- (5) The machine returns to the status that the front cover is opened.

Note:

If there is no operation for 60 seconds or more, the machine automatically returns to step (1).

2.3 Drum Unit Cleaning Mode

This mode is to remove the dust attached on the exposure drum. When white spots appear on the printout, perform this operation to remove the dust by using the drum cleaning sheet.

<Operating Procedure>

- (1) Load the drum cleaning sheet into the MP tray.
- (2) Check that the status LED lights in green and press the ◀ and **Clear/Back** buttons at the same time. "DRUM CLEANING" will appear on the LCD.
- (3) Press the **Black Start** button. The machine starts cleaning the drum unit. "DRUM CLEANING / PLEASE WAIT" appears on the LCD during cleaning.
- (4) When finishing cleaning normally, "DRUM CLEANING / COMPLETE" appears on the LCD.
- (5) Press the **Stop/Exit** button so that the machine returns to the ready state.

2.4 Fuser Motor Speed Adjustment Mode

<Function>

The problem such as dirt on the paper bottom or the unexpected print image due to a paper crease may be occurred when printing the thin paper. This mode allows you to change the speed of the fuser motor (Paper feed/belt cleaner motor ASSY) according to the respective problems.

<Operating Procedure>

- (1) Press the **2** and **8** buttons at the same time while the front cover is opened. "FU MOTOR SPEED / 0" will appear on the LCD.
- (2) Press the ▲ or ▼ button to choose the setting value and press the **OK** button. "FU MOTOR SPEED / Accepted" will appear on the LCD, and the setting value is saved.
 - Dirt on the paper bottom
Increase the fuser motor speed. (Setting value: 1, 2, 3)
 - Unexpected print image due to a paper crease
Reduce the fuser motor speed. (Setting value: -1, -2, -3)

Note:

Make sure to return the setting value to "0" after printing the thin paper. Failure to do so may cause color misregistration or dirt on the paper.

CHAPTER 6 CIRCUIT DIAGRAMS, WIRING DIAGRAM

Charge High-voltage Power Supply PCB Circuit Diagram (1/4)

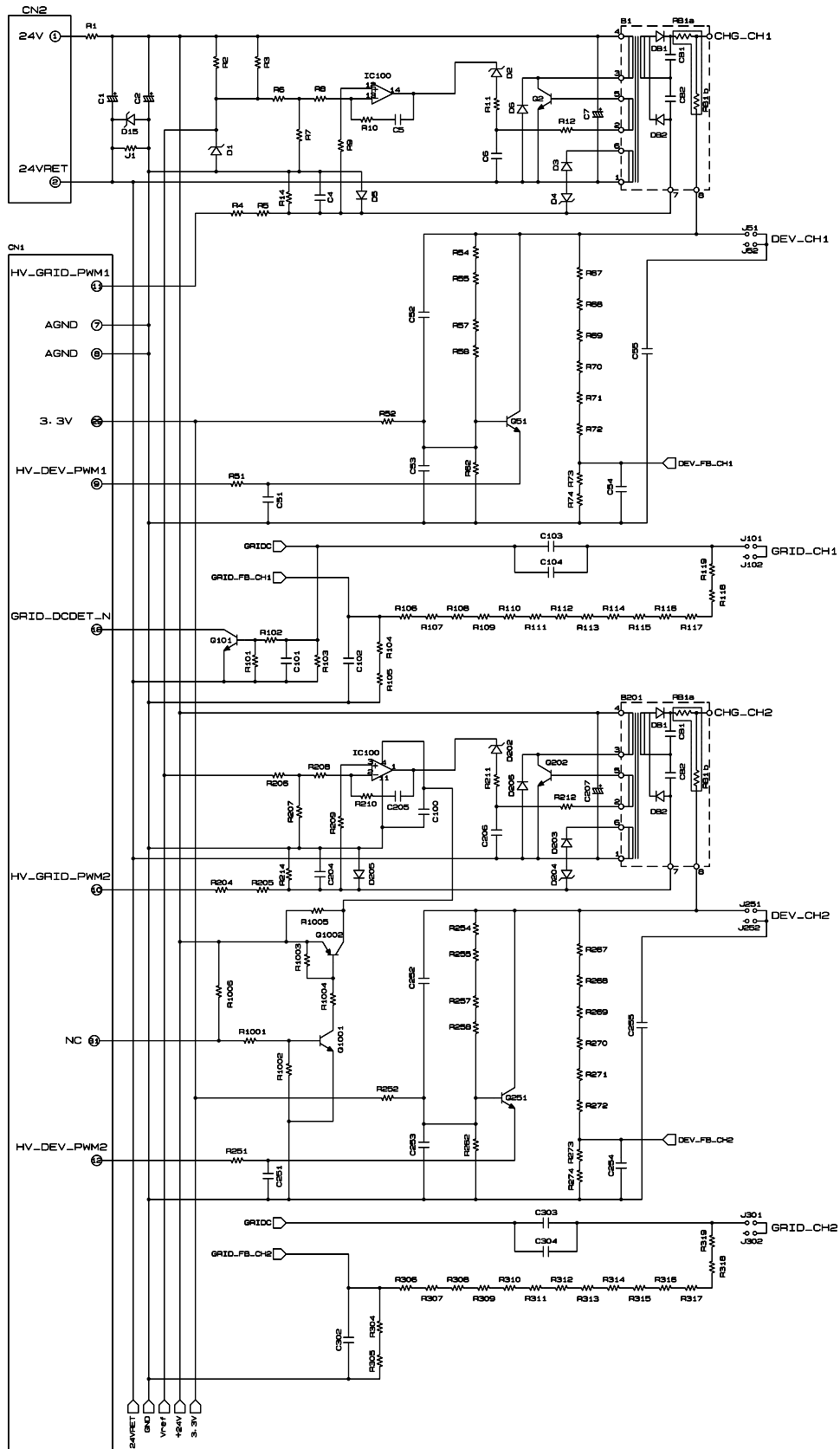

Charge High-voltage Power Supply PCB Circuit Diagram (2/4)

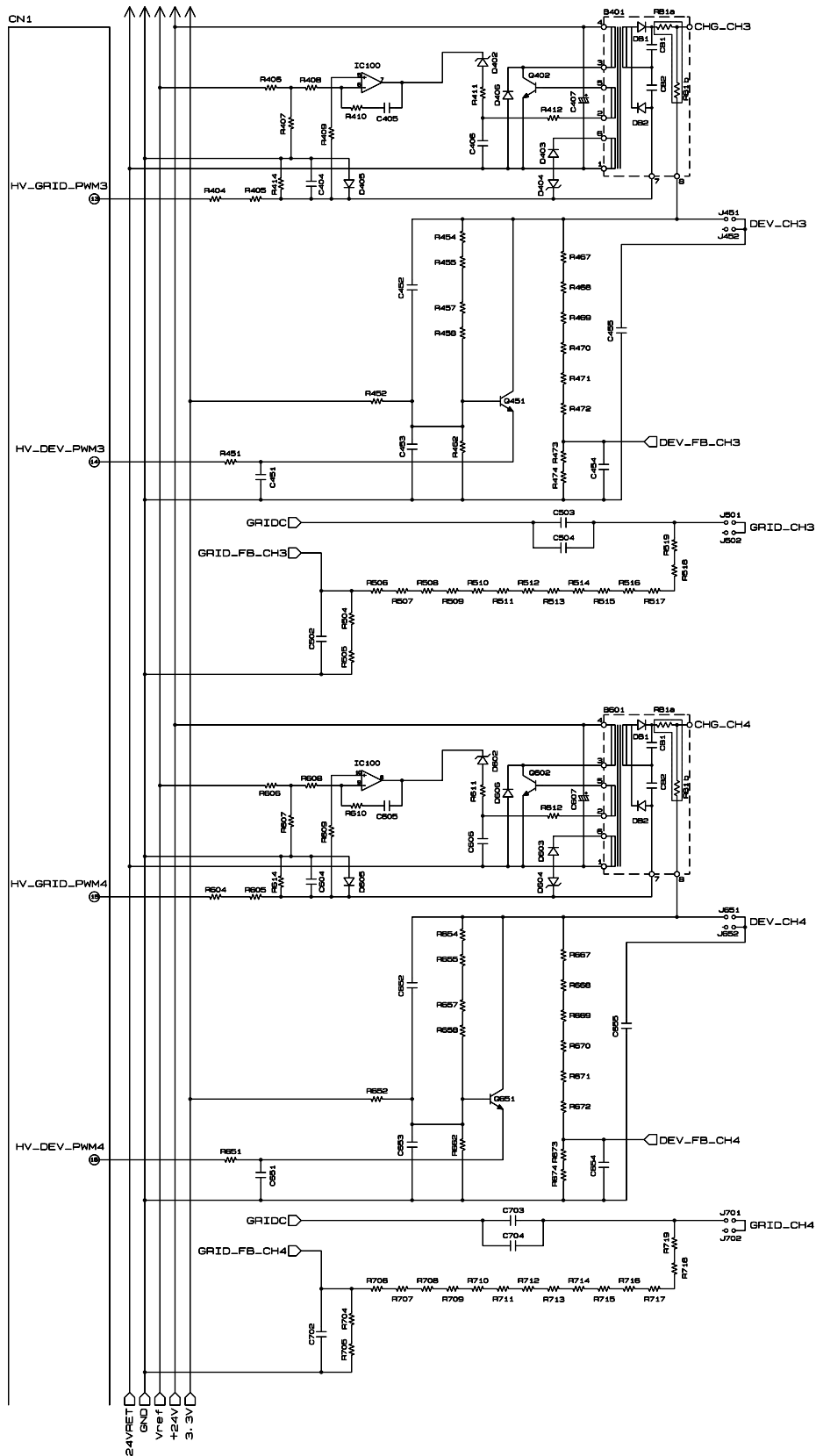

Charge High-voltage Power Supply PCB Circuit Diagram (3/4)

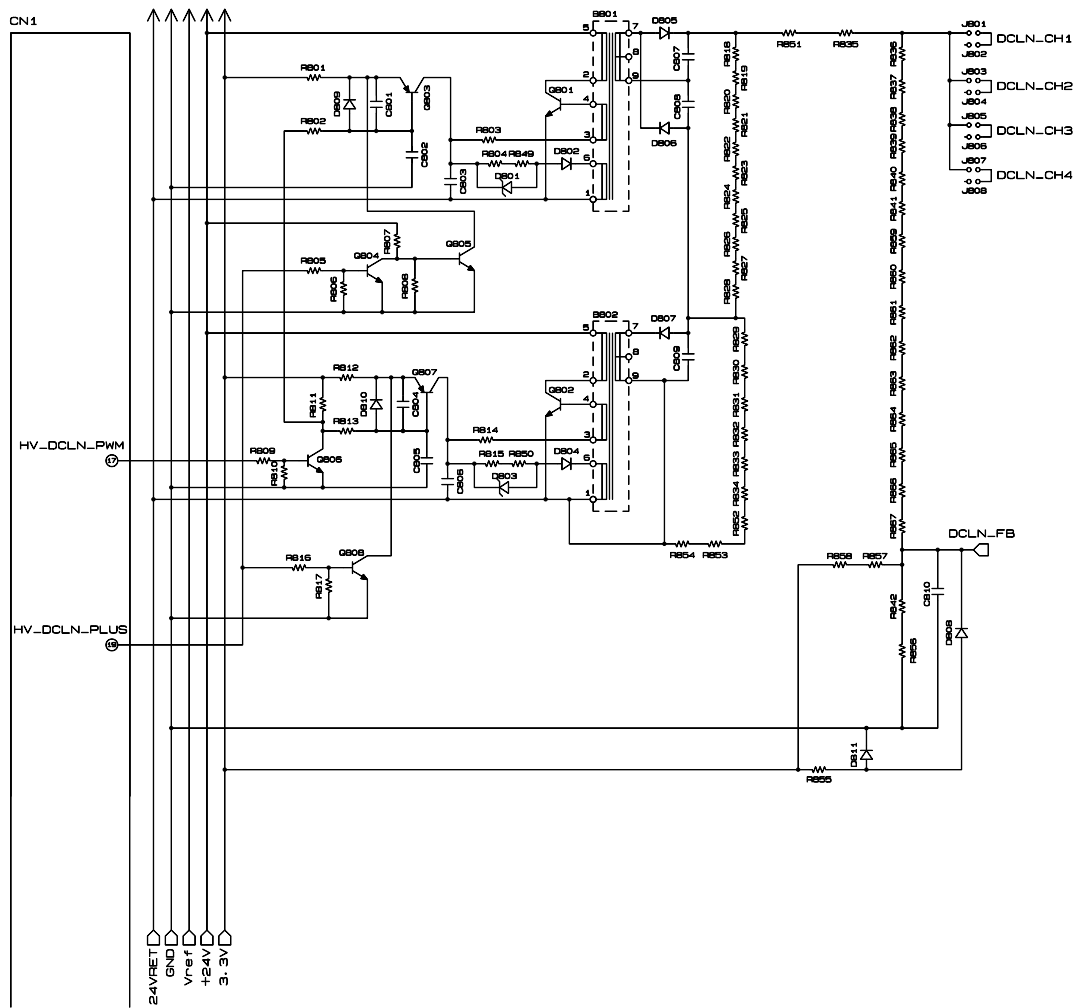

Charge High-voltage Power Supply PCB Circuit Diagram (4/4)

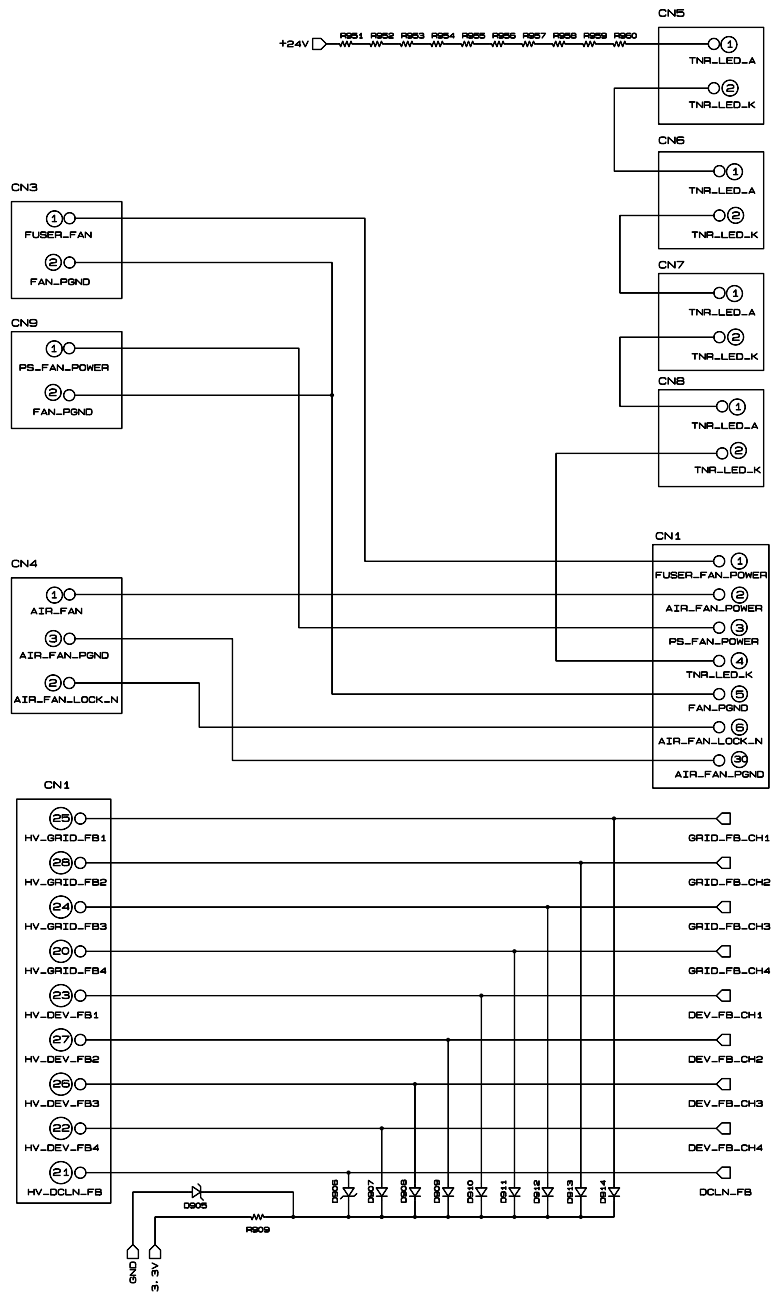

Transfer High-voltage Power Supply PCB Circuit Diagram (1/2)

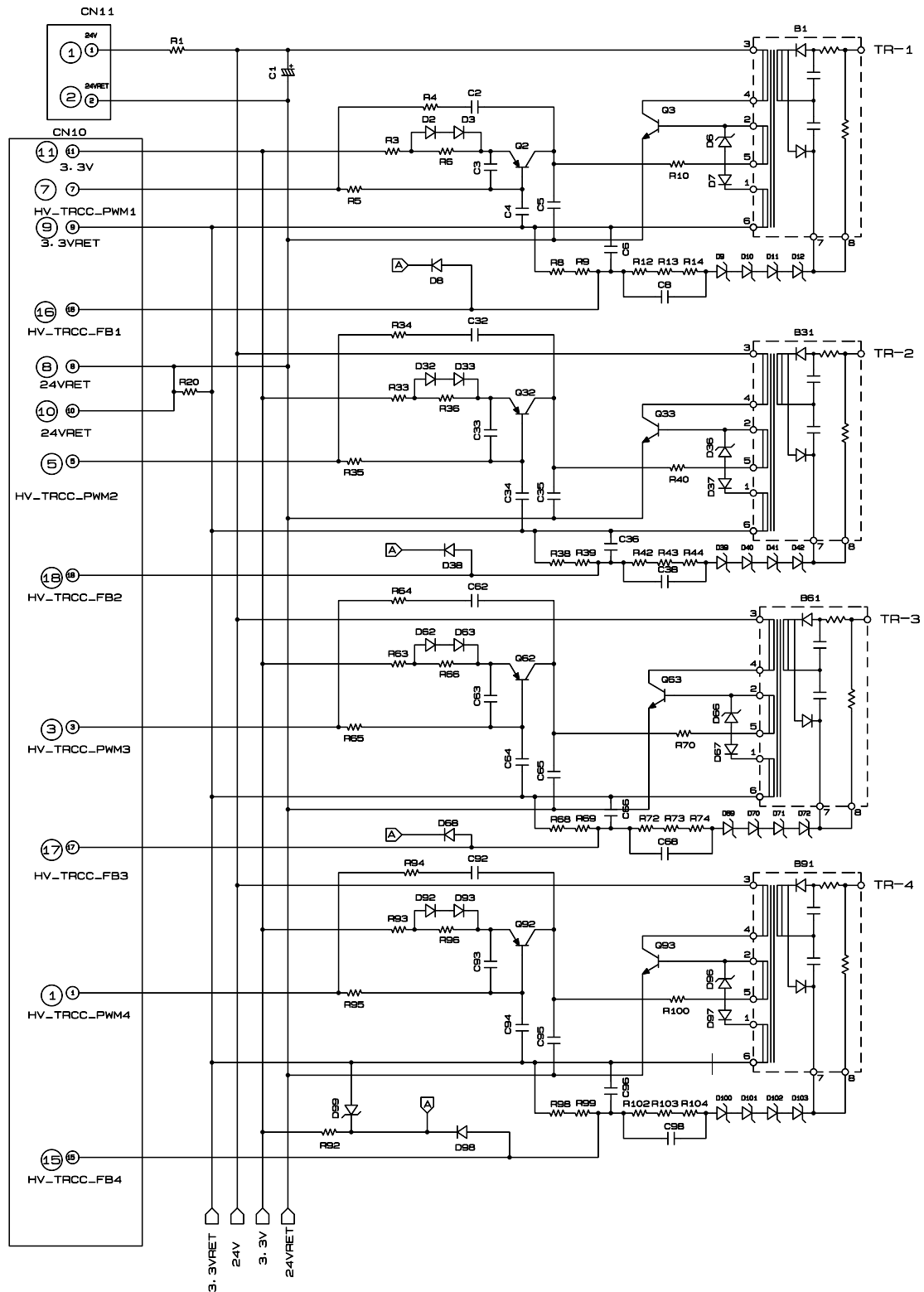

Transfer High-voltage Power Supply PCB Circuit Diagram (2/2)

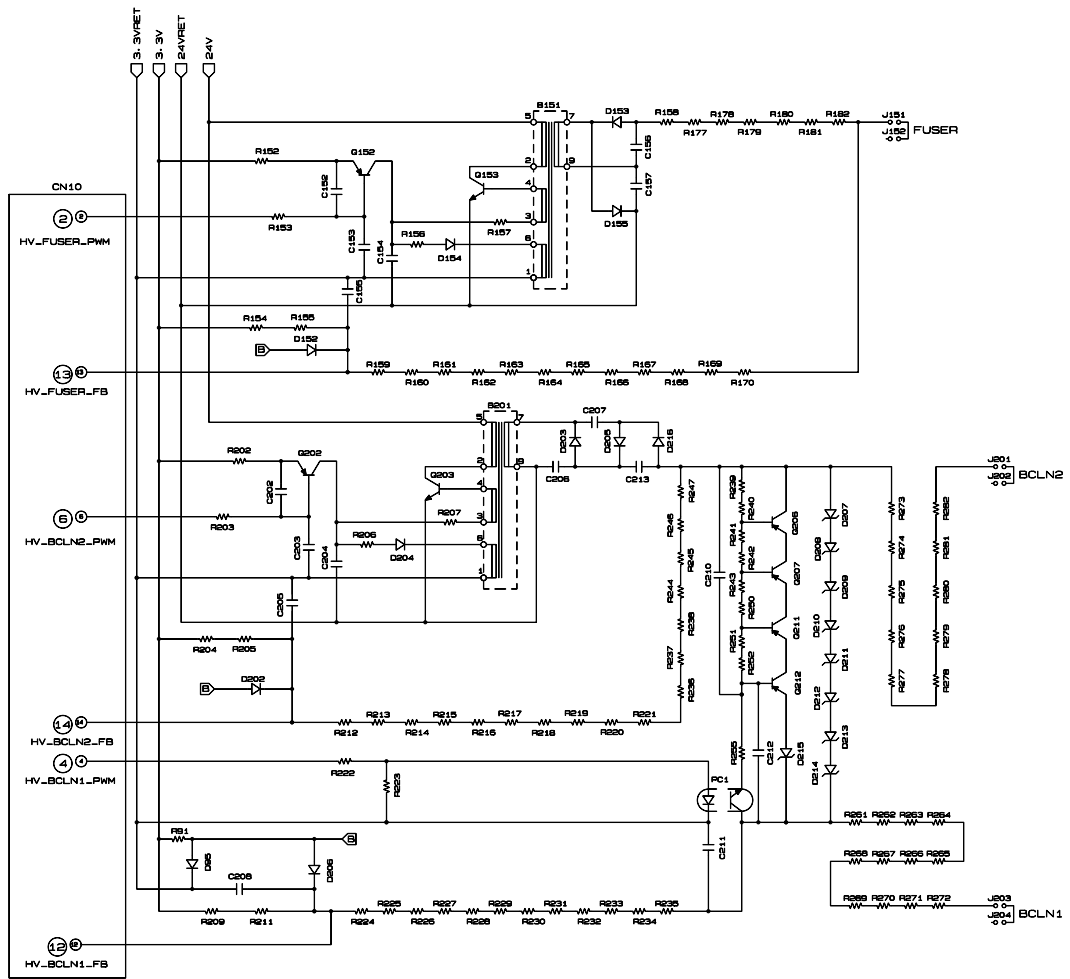

Low-voltage Power Supply PCB Circuit Diagram (100V)

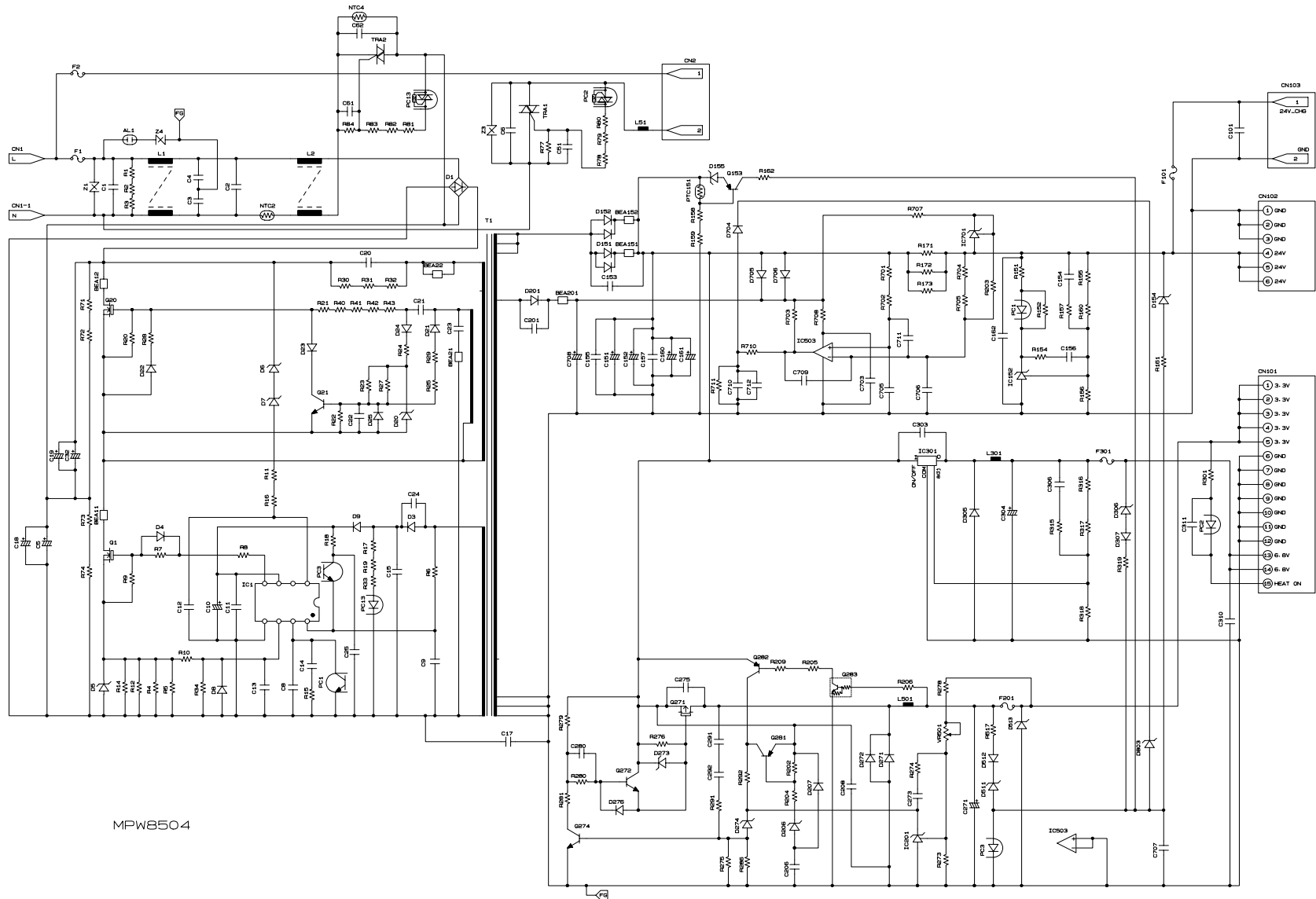

MPW8504

Low-voltage Power Supply PCB Circuit Diagram (200V)

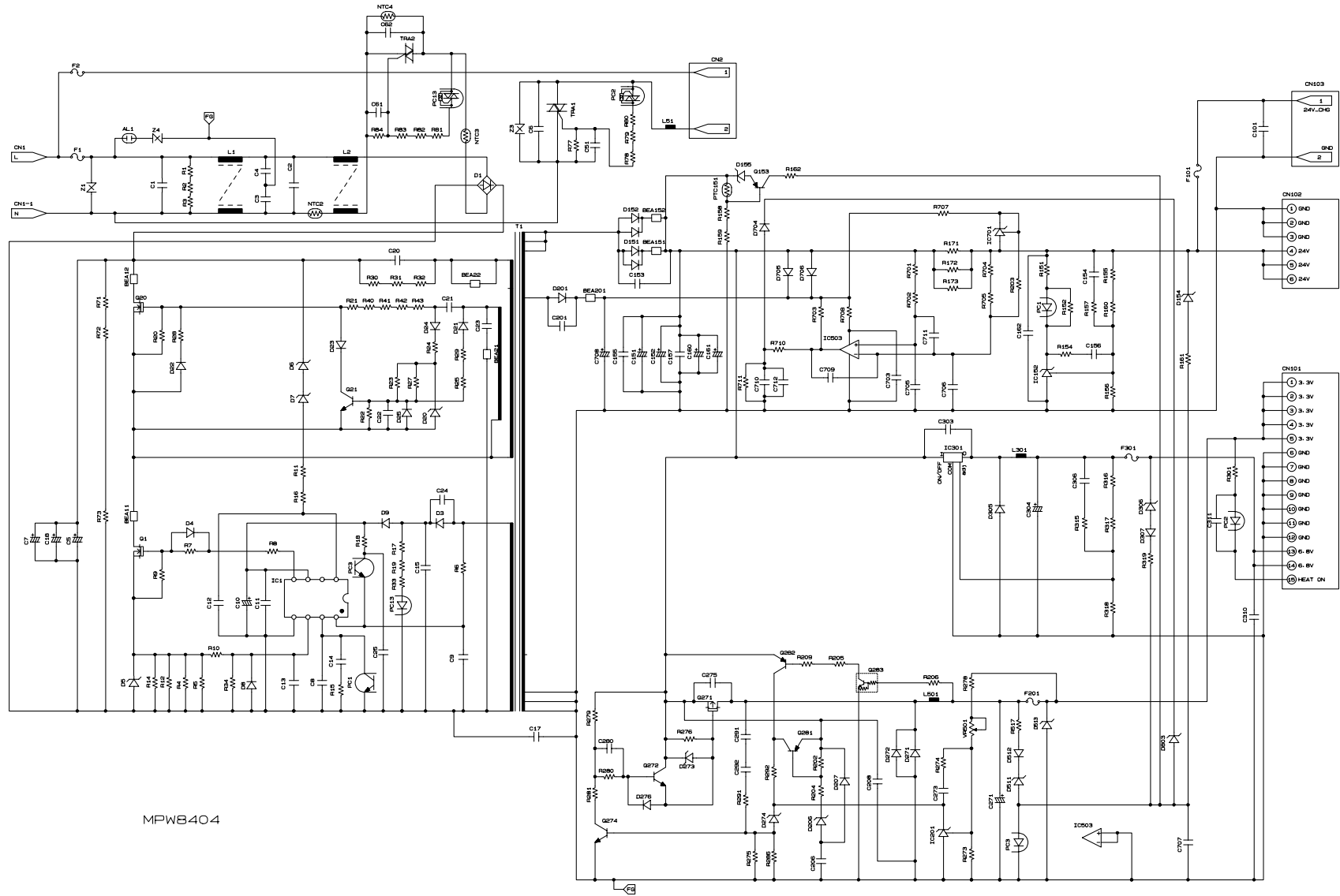

MPWB404

NCU PCB Circuit Diagram

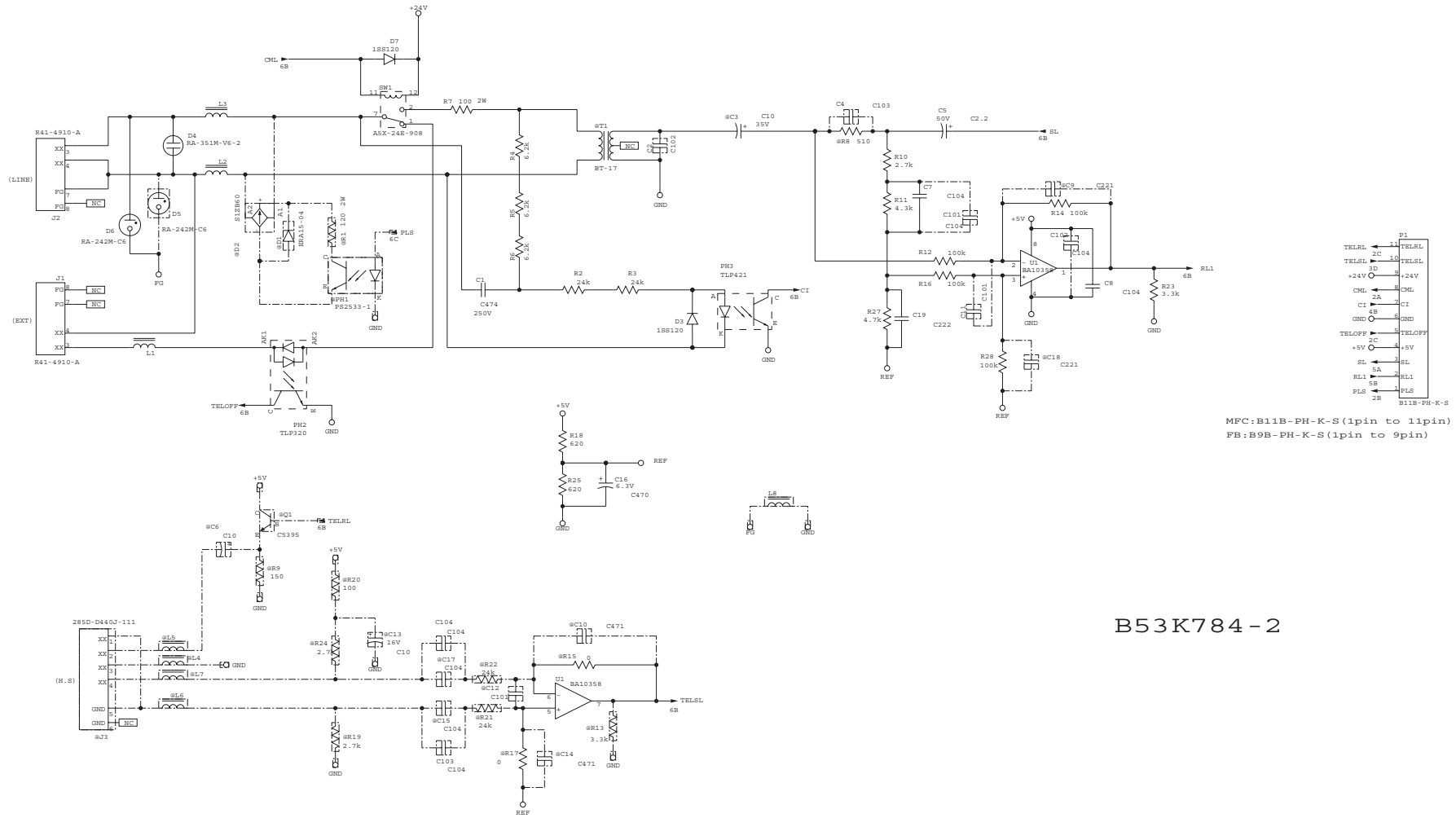

B53K784-2

■ **Filter PCB Circuit Diagram**

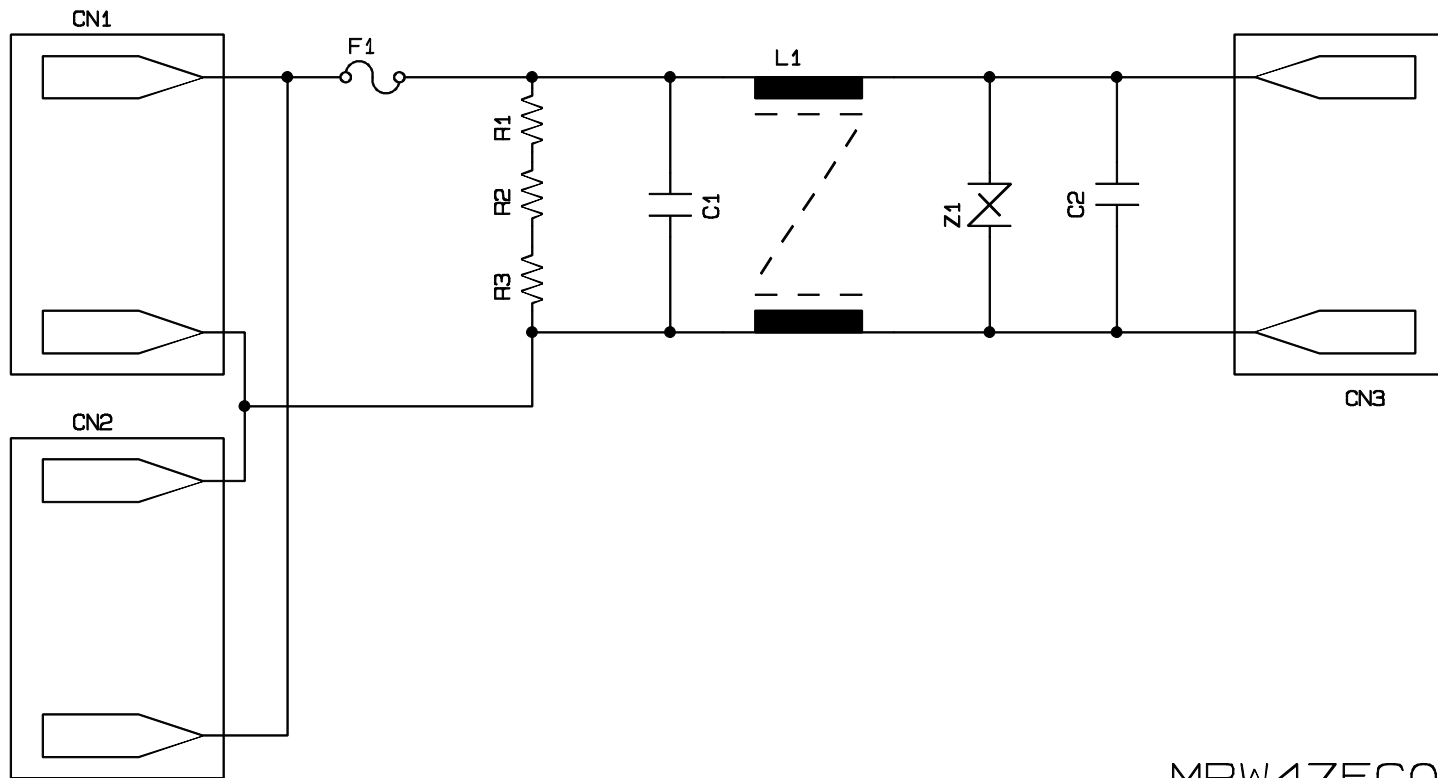

MPW47EC06

Wiring Diagram (1/2)

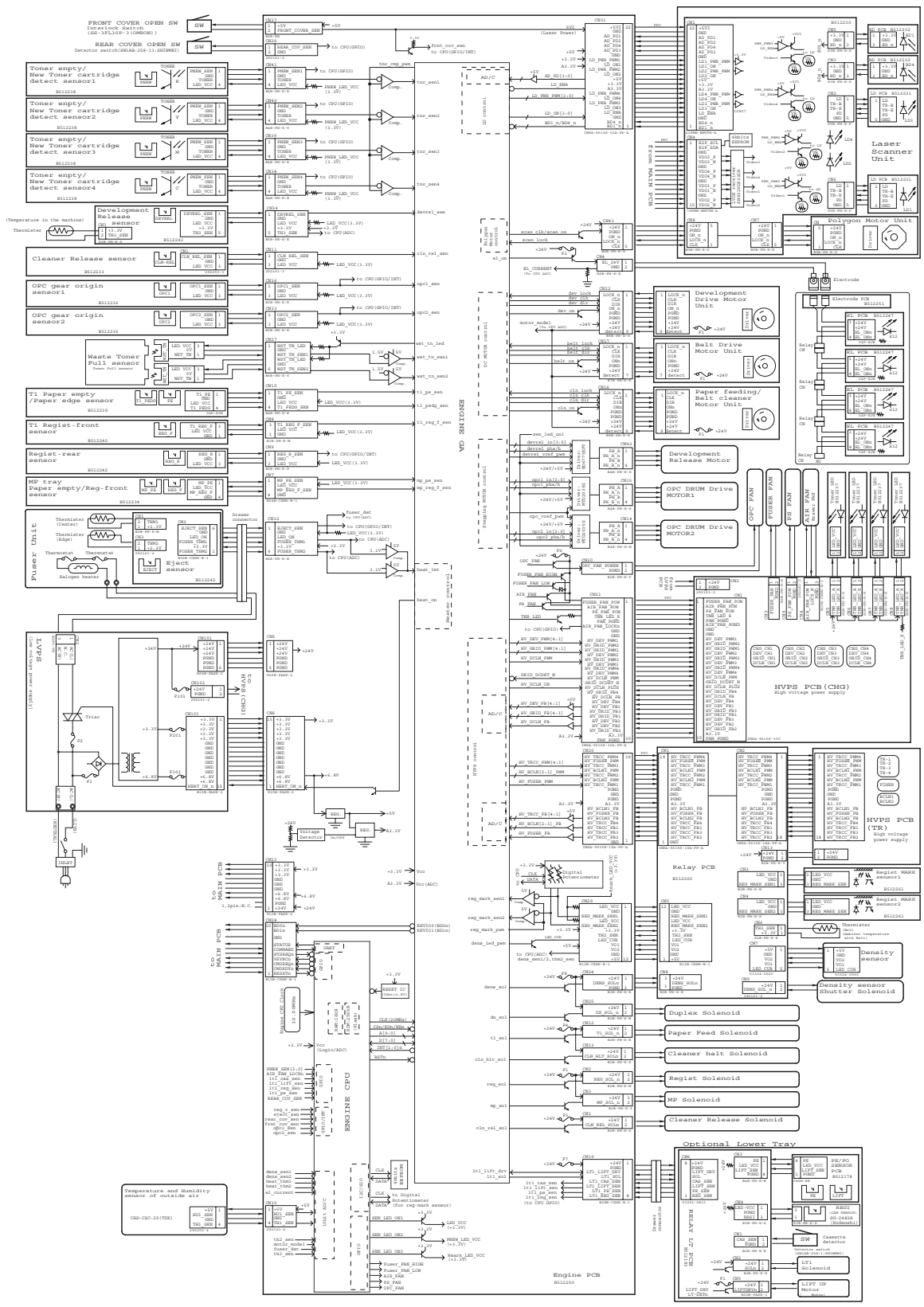

Wiring Diagram (2/2)

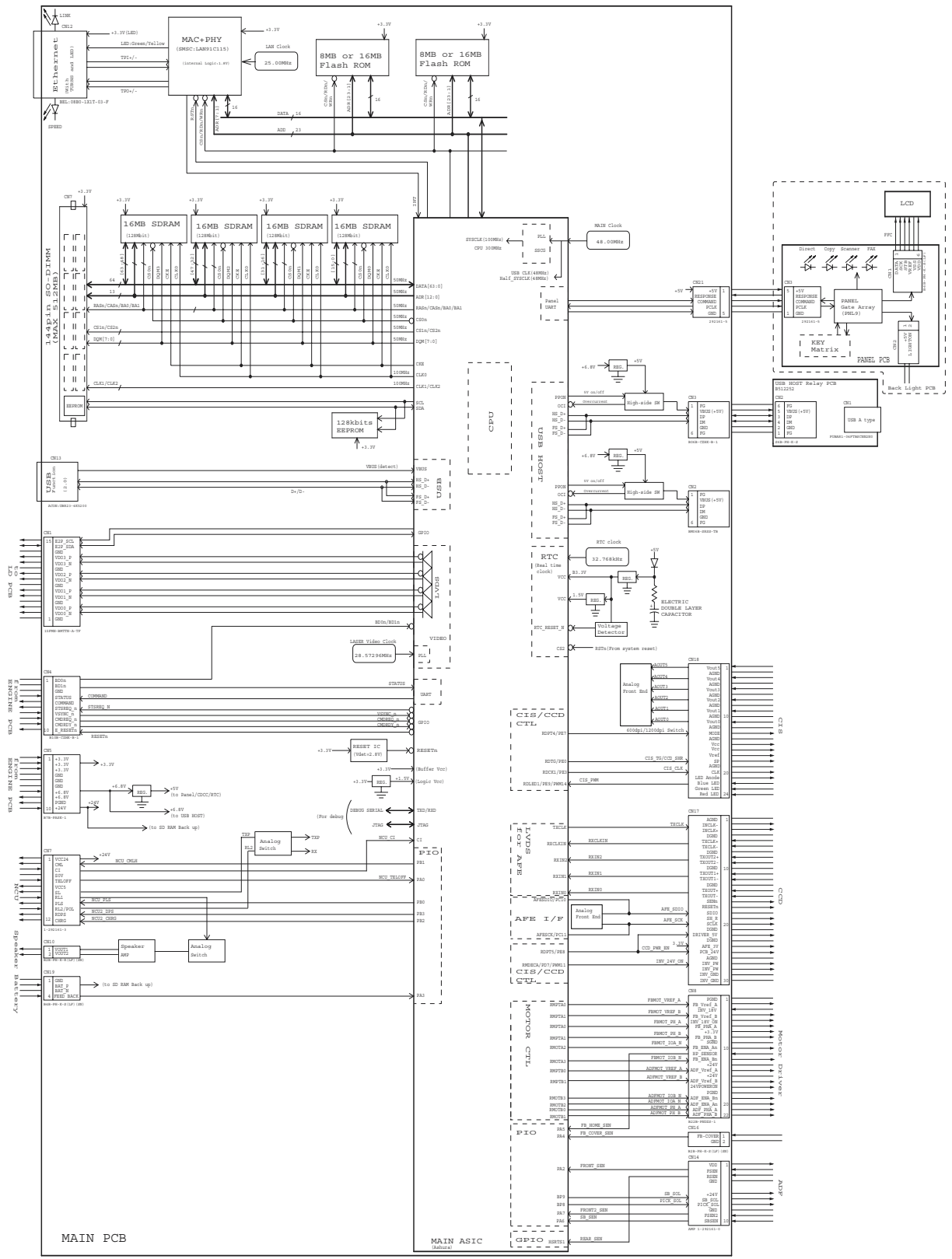

APPENDIX 1 WORKER SWITCH SETTINGS (WSW)

This appendix describes the functions of the Worker switches, which can be divided into two groups: one is for customizing preferences designed for the shipping destination (Refer to “1.4.20 EEPROM Customizing (Function Code 74)” in Chapter 5) and the other is for modifying preferences that match the machine to the environmental conditions. Use the latter group if the machine malfunctions due to mismatching.

Each switch has eight selectors. However, some of them cannot be set by an end user. Only selectors in the worker switch setting tables of this Appendix that are shaded can be set by an end user.

The worker switch setting procedure is described in Chapter 5, Section 1.4.6 [1] (Function Code 10).

■ Worker Switch

WSW No.	Function	Refer to:
WSW01	Dial pulse setting	App. 1-3
WSW02	Tone signal setting	App. 1-5
WSW03	PABX mode setting	App. 1-6
WSW04	Transfer facility setting	App. 1-8
WSW05	1st dial tone and busy tone detection	App. 1-9
WSW06	Redial/Pause button setting and 2nd dial tone detection	App. 1-10
WSW07	Dial tone setting 1	App. 1-12
WSW08	Dial tone setting 2	App. 1-13
WSW09	Protocol definition 1	App. 1-14
WSW10	Protocol definition 2	App. 1-15
WSW11	Busy tone setting	App. 1-16
WSW12	Signal detection condition setting	App. 1-17
WSW13	Modem setting	App. 1-18
WSW14	AUTO ANS facility setting	App. 1-19
WSW15	Redial facility setting	App. 1-20
WSW16	Function setting 1	App. 1-21
WSW17	Function setting 2	App. 1-22
WSW18	Function setting 3	App. 1-23
WSW19	Transmission speed setting	App. 1-24
WSW20	Overseas communications mode setting	App. 1-25
WSW21	TAD setting 1	App. 1-26
WSW22	ECM and call waiting caller ID	App. 1-27
WSW23	Communications setting	App. 1-28
WSW24	TAD setting 2	App. 1-29
WSW25	TAD setting 3	App. 1-30

WSW No.	Function	Refer to:
WSW26	Function setting 4	App. 1-31
WSW27	Function setting 5	App. 1-32
WSW28	Function setting 6	App. 1-33
WSW29	Function setting 7	App. 1-34
WSW30	Function setting 8	App. 1-35
WSW31	Function setting 9	App. 1-36
WSW32	Function setting 10	App. 1-37
WSW33	Function setting 11	App. 1-38
WSW34	Function setting 12	App. 1-39
WSW35	Function setting 13	App. 1-40
WSW36	Function setting 14	App. 1-40
WSW37	Function setting 15	App. 1-42
WSW38	V.34 transmission settings	App. 1-43
WSW39	V.34 transmission speed	App. 1-44
WSW40	V.34 modem settings	App. 1-45
WSW41	ON-duration of the scanning light source	App. 1-47
WSW42	Internet mail settings	App. 1-48
WSW43	Function setting 21	App. 1-48
WSW44	Speeding up scanning-1	App. 1-49
WSW45	Speeding up scanning-2	App. 1-50
WSW46	Monitor of power ON/OFF state and parallel port kept at high	App. 1-51
WSW47	Switching between high- and full-speed USB	App. 1-52
WSW48	USB setup latency	App. 1-53
WSW49	End-of-copying beep and print in black	App. 1-54
WSW50	SDAA settings	App. 1-55
WSW51	Function setting 16	App. 1-56
WSW52	Function setting 17	App. 1-57
WSW53	Function setting 18	App. 1-58
WSW54	Function setting 19	App. 1-59
WSW55	Function setting 20	App. 1-60
WSW56	Function setting 21	App. 1-60
WSW57	Function setting 22	App. 1-61
WSW58	Function setting 23	App. 1-62
WSW59	Function setting 24	App. 1-62
WSW60	Not used.	App. 1-63
WSW61	Judgment of scanning light intensity stability 1	App. 1-63
WSW62	Judgment of scanning light intensity stability 2	App. 1-64

The functions and settings for each worker switch (WSW) are described below;

< **WSW01** >

Selector No.	Function	Setting and Specifications
1 2	Dial pulse generation mode	No. 1 2 0 0 : N 0 1 : N+1 1 0 : 10-N 1 1 : N
3 4	Break time length in pulse dialing	No. 3 4 0 0 : 60 ms 0 1 : 67 ms 1 0 : 40 ms 1 1 : 64 ms (for 16 PPS)
5 6	Inter-digit pause	No. 5 6 0 0 : 800 ms 0 1 : 850 ms 1 0 : 950 ms (for 16 PPS) 1 1 : 600 ms (at 106-ms intervals)
7	Switching between pulse and tone dialing, by the function switch	0: Yes 1: No
8	Default dialing mode, pulse (DP) or tone (PB) dialing	0: PB 1: DP

- Selectors 1 and 2: Dial pulse generation mode

These selectors set the number of pulses to be generated in pulse dialing.

N: Dialing "N" generates "N" pulses. (Dialing "0" generates 10 pulses.)

N + 1: Dialing "N" generates "N + 1" pulses.

10 - N: Dialing "N" generates "10 - N" pulses.

- Selectors 3 and 4: Break time length in pulse dialing

These selectors set the break time length in pulse dialing.

(Example: If "1," "2," and "3" are dialed when N is set by selectors 1 and 2.)

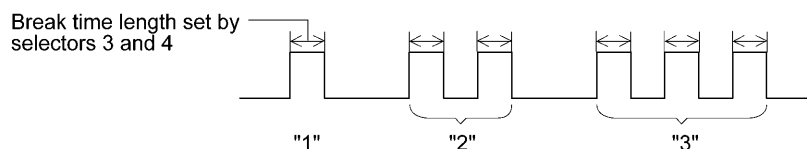

- Selectors 5 and 6: Inter-digit pause

These selectors set the inter-digit pause in pulse dialing.

(Example: If "1," "2," and "3" are dialed when N is set by selectors 1 and 2.)

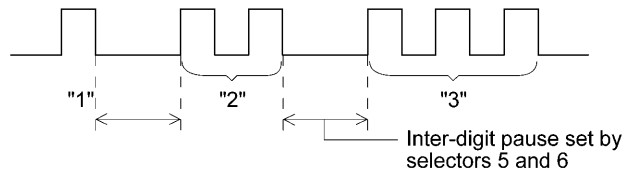

- Selector 7: Switching between pulse and tone dialing, by the function switch

This selector determines whether or not the dialing mode can be switched between the pulse (DP) and tone (PB) dialing by using the function switch.

- Selector 8: Default dialing mode, pulse (DP) or tone (PB) dialing

This selector sets the default dialing mode (pulse dialing or tone dialing) which can be changed by the function switch. If the user switches it with the function switch when selector 7 is set to "0," the setting specified by this selector will also be switched automatically.

< WSW02 >

Selector No.	Function	Setting and Specifications
1 2	Tone signal transmission time length	No. 1 2 0 0 : 70 ms 0 1 : 80 ms 1 0 : 90 ms 1 1 : 100 ms
3 4	Min. pause in tone dialing	No. 3 4 0 0 : 70 ms 0 1 : 80 ms 1 0 : 90 ms 1 1 : 140 ms
5 8	Attenuator for pseudo ring backtone to the line (selectable in the range of 0-15 dB, in 1 dB increments)	0: 0 dB 1: 8 dB 0: 0 dB 1: 4 dB 0: 0 dB 1: 2 dB 0: 0 dB 1: 1 dB

- Selectors 1 through 4: Tone signal transmission time length and Min. pause in tone dialing

These selectors set the tone signal transmission time length and minimum pause in tone dialing.

(Example: If "1," "2," "3," "4," and "5" are dialed.)

Tone signal transmission time length set by selectors 1 and 2

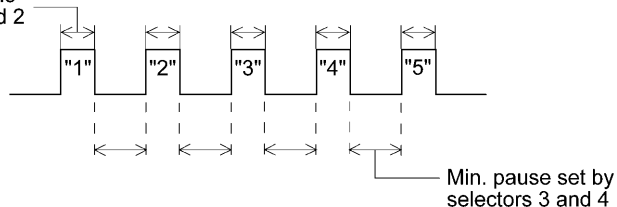

- Selectors 5 through 8: Attenuator for pseudo ring backtone to the line

These selectors are used to adjust the sound volume of a ring backtone in the F/T mode, an on-hold sound, or a beep generated as a signal during remote control operation or at the start of ICM recording.

The larger the value specified by these selectors, the greater the attenuation.

< WSW03 >

Selector No.	Function	Setting and Specifications
1	CNG detection when sharing a modular wall socket with a telephone	0: A 1: B
2 4	Detection time length of PABX* dial tone, required for starting dialing	No. 2 3 4 0 0 0: 50 ms 0 0 1: 210 ms 0 1 0: 500 ms 0 1 1: 800 ms 1 0 0: 900 ms 1 0 1: 1.5 sec. 1 1 0: 2.0 sec. 1 1 1: 2.5 sec.
5	CNG detection when sharing a modular wall socket with a telephone	0: A 1: B
6 7	Dial tone detection in PABX*	No. 6 7 0 0 : No detection (3.5 sec. wait) 0 1 : No detection (5 sec. wait) 1 0 : No detection (7 sec. wait) 1 1 : Detection (Frequency only)
8	Not used.	

* PABX: Private automatic branch exchange

Note:

Selectors 2 through 4, 6 and 7 are not applicable where no PABX is installed.

- Selectors 1 and 5: CNG detection when sharing a modular wall socket with a telephone

These selectors determine whether or not the machine detects a CNG signal when a line is connected to a telephone sharing a modular wall socket with the machine. Upon detection of CNG signals by the number of cycles specified by these selectors, the machine interprets CNG as an effective signal and then starts FAX reception.

Selector		Cycle
No. 1	No. 5	
0 (A)	0 (A)	0.5 cycle
0 (A)	1 (B)	1.0 cycle
1 (A)	0 (A)	1.5 cycle
1 (B)	1 (B)	2.0 cycle

- Selectors 2 through 4: Detection time length of PABX dial tone, required for starting dialing

Upon detection of the PABX dial tone for the time length set by these selectors, the machine starts dialing. These selectors are effective only when both selectors 6 and 7 are set to "1" (Detection).

- Selectors 6 and 7: Dial tone detection in PABX*

These selectors activate or deactivate the dial tone detection function which detects a dial tone when a line is connected to the PABX.

Setting both of these selectors to "1" activates the dial tone detection function so that the machine starts dialing upon detection of a dial tone when a line is connected.

Other setting combinations deactivate the dial tone detection function so that the machine starts dialing after the specified WAIT (3.5, 5.0, or 7.0 sec.) without detection of a dial tone when a line is connected.

< WSW04 >

Selector No.	Function	Setting and Specifications
1	Earth function in transfer facility (Not used.)	0: Provided 1: Not provided
2 3	Dual tone detection frequency in ICM recording	No. 2 3 0 0: 350 and 440 Hz (A) 0 1: 440 and 480 Hz (B) 1 0: 480 and 620 Hz (C) 1 1: 480 and 620 Hz (C)
4	Dual tone detection sensitivity in ICM recording	0: Normal 1: High
5	Length of time added to time designated by selectors 3 and 4 on the WSW 24 (time between CML ON and pseudo ring backtone return).	0: Not added 1: +4 seconds added
6 8	Break time length for flash function	No. 6 7 8 0 0 0: 80 ms 0 0 1: 100 ms 0 1 0: 110 ms 0 1 1: 120 ms 1 0 0: 200 ms 1 0 1: 250 ms 1 1 0: 500 ms 1 1 1: 700 ms

Note:

- Selectors 1 and 5 through 8 are not applicable in those countries where no transfer facility is supported.
- Selectors 2 through 4 are applicable to models equipped with built-in TADs.

- Selector 1: Earth function in transfer facility (Not used.)

This selector determines whether or not the earth function is added to the transfer setting menu to be accessed by the function switch.

- Selectors 2 and 3: Dual tone detection frequency in ICM recording

If the machine detects either of the frequencies set by these selectors in ICM recording, it disconnects the line. For example, if these selectors are set to "0, 0" the machine disconnects the line upon detection of 350 Hz or 440 Hz.

- Selector 4: Dual tone detection sensitivity in ICM recording

Setting this selector to "1" increases the tone detection sensitivity in ICM recording.

- Selectors 6 and 8: Break time length for flash function

These selectors set the break time length. This setting is effective only when the flash function is selected for the **Search/Speed Dial** button by using the function switch.

< WSW05 >

Selector No.	Function	Setting and Specifications
1 3	1st dial tone detection	No. 1 2 3 0 0 0: 3.5 sec. wait 0 0 1: 7.0 sec. wait 0 1 0: 10.5 sec. wait 0 1 1: 14.0 sec. wait 1 0 0: 17.5 sec. wait 1 0 1: 21.0 sec. wait 1 1 0: 25.0 sec. wait 1 1 1: Detection (Without wait)
4	Max. pause time allowable for remote ID code detection	0: 2 sec. 1: 1 sec.
5 6	Busy tone detection in auto-matic sending mode	No. 5 6 0 0: No detection 0 1: Detection only after dialing 1 0: No detection 1 1: Detection before and after dialing
7	Busy tone detection in auto-matic receiving mode	0: Yes 1: No
8	Not used.	

Note:

Selectors 5 through 7 are not applicable in those countries where no busy tone detection is supported.

- Selectors 1 through 3: 1st dial tone detection

These selectors activate or deactivate the 1st dial tone detection function which detects the 1st dial tone issued from the PSTN when a line is connected to the PSTN.

Setting all of these selectors to "1" activates the dial tone detection function so that the machine starts dialing upon detection of a dial tone when a line is connected. (However, in those countries which support no dial tone detection function, e.g., in the U.S.A., setting these selectors to "1" makes the machine start dialing after a WAIT of 3.5 seconds.) For the detecting conditions of the 1st dial tone, refer to WSW07 and WSW08.

Other setting combinations deactivate the dial tone detection function so that the machine starts dialing after the specified WAIT (3.5, 7.0, 10.5, 14.0, 17.5, 21.0, or 24.5 seconds) without detection of a dial tone when a line is connected to the PSTN.

- Selector 4: Max. pause time allowable for remote ID code detection

This selector sets the maximum pause time allowable for detecting the second digit of a remote ID code after detection of the first digit in remote reception.

If selector 4 is set to "0" (2 seconds), for instance, only a remote ID code whose second digit is detected within 2 seconds after detection of the first digit will become effective so as to activate the remote function.

- Selectors 5 and 6: Busy tone detection in automatic sending mode

These selectors determine whether or not the machine automatically disconnects a line upon detection of a busy tone in automatic sending mode.

Setting selector 6 to "0" ignores a busy tone so that the machine does not disconnect the line. Setting selectors 5 and 6 to "0" and "1," respectively, makes the machine detect a busy tone only after dialing and disconnect the line.

Setting both of selectors 5 and 6 to "1" makes the machine detect a busy tone before and after dialing and then disconnect the line.

- Selector 7: Busy tone detection in automatic receiving mode

This selector determines whether or not the machine automatically disconnects the line upon detection of a busy tone in automatic receiving mode.

< WSW06 >

Selector No.	Function	Setting and Specifications
1 3	Redial/Pause button setting and 2nd dial tone detection	No. 1 2 3 0 0 0: No pause 0 0 1: 3.5 sec. wait 0 1 0: 7 sec. wait 0 1 1: 10.5 sec. wait 1 0 0: 2.8 sec. wait 1 0 1: 2nd dial tone detection both in DP and push-button (PB) dialing system 1 1 0: 2nd dial tone detection only in pulse dialing (DP) system 1 1 1: 2nd dial tone detection both in DP and push-button (PB) dialing system
4 6	Detection of international tone	No. 4 5 6 0 0 0: 50 ms 0 0 1: 250 ms 0 1 0: 500 ms 0 1 1: 620 ms 1 0 0: 800 ms 1 0 1: 1.5 sec. 1 1 0: 2.0 sec. 1 1 1: 2.5 sec.
7	No. of 2nd dial tone detection cycles	0: 1 cycle 1: 2 cycles
8	Allowable instantaneous interrupt during reception of 2nd dial tone	0: 30 ms 1: 50 ms

Note:

Selectors 4 through 8 are not applicable in those countries where no dial tone detection is supported, e.g., U.S.A.

- Selectors 1 through 3: Redial/Pause button setting and 2nd dial tone detection

Selectors			
1	2	3	
0	0	0	No wait is inserted even if the Redial/Pause button is pressed.
0	0	1	If you press the Redial/Pause button during dialing, the machine will insert wait as defined in the above table.
0	1	0	
0	1	1	If the Redial/Pause button is pressed repeatedly, the machine inserts the specified wait multiplied by the number of depressions. It applies also in hook-up dialing.
1	0	0	
1	0	1	When these selectors are set to "1, 0, 1":
1	1	0	Each time you press the Redial/Pause button in dialing, the machine will wait for the 2nd dial tone to be sent via the communications line regardless of pulse dialing or tone dialing.
1	1	1	
			When these selectors are set to "1, 1, 0":
			If you press the Redial/Pause button in pulse dialing, the machine will first wait for the 2nd dial tone to be sent via the communications line. After that, pressing the Redial/Pause button will cause the machine to insert a WAIT of 3.5 seconds. In tone dialing, the machine will insert a WAIT of 3.5 seconds.
			When these selectors are set to "1, 1, 1":
			If you press the Redial/Pause button, the machine will first wait for the 2nd dial tone to be sent via the communications line regardless of pulse dialing or tone dialing. After that, pressing the Redial/Pause button will cause the machine to insert a wait of 3.5 seconds.
			((In those countries where no dial tone detection function is supported, setting these selectors to "1, 0, 1," "1, 1, 0," or "1, 1, 1" inserts a wait of 3.5 seconds.)

- Selectors 4 through 6: Detection of international tone

Upon detection of the 2nd dial tone for the time length specified by these selectors, the machine starts dialing.

This setting is effective only when the 2nd dial tone detection function is activated by selectors 1 through 3 (Setting 101, 110, or 111).

This function does not apply in those countries where no dial tone detection function is supported.

- Selector 7: No. of 2nd dial tone detection cycles

This selector sets the number of dial tone detection cycles required for starting dialing.

- Selector 8: Allowable instantaneous interrupt during reception of 2nd dial tone

This selector sets the allowable instantaneous interrupt period that should be ignored during reception of the 2nd dial tone.

< WSW07 >

Selector No.	Function	Setting and Specifications
1 2	Dial tone frequency band control	No. 1 2 0 0: Narrows by 10 Hz 0 1: Initial value 1 0: Widens by 10 Hz 1 1: Widens by 10 Hz
3	Line current detection (Not used.)	0: No 1: Yes
4 6	2nd dial tone detection level (Z = 600 Ω)	No. 4 5 6 0 0 0: -21 dBm 0 0 1: -24 dBm 0 1 0: -27 dBm 0 1 1: -30 dBm 1 0 0: -33 dBm 1 0 1: -36 dBm 1 1 0: -39 dBm 1 1 1: -42 dBm
7	Allowable instantaneous interrupt during reception of 1st dial tone	0: 30 ms 1: 50 ms
8	Not used.	

Note:

- Selectors 1, 2, 4 through 7 are not applicable in those countries where no dial tone or line current detection is supported, e.g., U.S.A.
- Selector 3 is not applicable to those models having no loop current detection function.

- Selectors 1 and 2: Dial tone frequency band control

These selectors set the frequency band for the 1st dial tone and busy tone (before dialing) to be detected. This setting is effective only when selectors 1 through 3 on WSW05 are set to "1,1,1."

- Selector 3: Line current detection (Not used.)

This selector determines whether or not to detect a line current before starting dialing.

- Selectors 4 through 6: 2nd dial tone detection level

These selectors set the detection level of the 2nd dial tone.

- Selector 7: Allowable instantaneous interrupt during reception of 1st dial tone

This selector sets the allowable instantaneous interrupt period that should be ignored during reception of the 1st dial tone.

< WSW08 >

Selector No.	Function	Setting and Specifications
1 3	1st dial tone detection time length	No. 1 2 3 0 0 0: 50 ms 0 0 1: 250 ms 0 1 0: 500 ms 0 1 1: 620 ms 1 0 0: 800 ms 1 0 1: 1.5 sec. 1 1 0: 2.0 sec. 1 1 1: 2.5 sec.
4 5	Time-out length for 1st and 2nd dial tone detection	No. 4 5 0 0: 10 sec. 0 1: 20 sec. 1 0: 15 sec. 1 1: 30 sec.
6 8	Detection level of 1st dial tone and busy tone before dialing	No. 6 7 8 0 0 0: -21 dBm 0 0 1: -24 dBm 0 1 0: -27 dBm 0 1 1: -30 dBm 1 0 0: -33 dBm 1 0 1: -36 dBm 1 1 0: -39 dBm 1 1 1: -42 dBm

Note:

The WSW08 is not applicable in those countries where no dial tone detection is supported, e.g., U.S.A.

- Selectors 1 through 3: 1st dial tone detection time length

Upon detection of the 1st dial tone for the time length set by these selectors, the machine starts dialing. This setting is effective only when selectors 1 through 3 on WSW05 are set to "1,1,1."

- Selectors 4 and 5: Time-out length for 1st and 2nd dial tone detection

These selectors set the time-out length for the 1st and 2nd dial tone detection so that the machine waits dial tone input for the specified time length and disconnects itself from the line when no dial tone is inputted.

< WSW09 >

Selector No.	Function	Setting and Specifications	
1	Frame length selection	0: 256 octets	1: 64 octets
2	Use of non-standard commands	0: Allowed	1: Prohibited
3 4	No. of retries	No. 3 4 0 0: 4 times 0 1: 3 times 1 0: 2 times 1 1: 1 times	
5	T5 timer	0: 300 sec.	1: 60 sec.
6	T1 timer	0: 35 sec.	1: 40 sec.
7 8	Timeout for response from the called station in automatic sending mode	No. 7 8 0 0: 55 sec. (in U.S.A. and Canadian models) 60 sec. (in other models) 0 1: 140 sec. 1 0: 90 sec. 1 1: 35 sec.	

Note:

Selectors 1 through 5 are not applicable in those models which do not support ECM.

- Selector 1: Frame length selection

Usually a single frame consists of 256 octets (1 octet = 8 bits). For communications lines with higher bit error rate, however, set selector 1 to "1" so that the machine can divide a message into 64-octet frames.

Remarks: The error correction mode (ECM) is a facsimile transmission manner in which the machine divides a message into frames for transmission so that if any data error occurs on the transmission line, the machine retransmits only those frames containing the error data.

- Selector 2: Use of non-standard commands

If this selector is set to "0," the machine can use non-standard commands (the machine's native-mode commands, e.g., NSF, NSC, and NSS) for communications. If it is set to "1," the machine will use standard commands only.

- Selectors 3 and 4: No. of retries

These selectors set the number of retries in each specified modem transmission speed.

- Selector 5: T5 timer

This selector sets the time length for the T5 timer.

- Selector 6: T1 timer

This selector sets the time length for the T1 timer.

- Selectors 7 and 8: Timeout for response from the called station in automatic sending mode

If the machine (calling station) receives no response (no G3 command) from the called terminal in automatic sending mode for the period specified by these selectors, it disconnects the line.

< WSW10 >

Selector No.	Function	Setting and Specifications
1	DPS switching interfacing with CML	0: No 1: Yes
2	Time length from transmission of the last dial digit to CML ON	0: 100 ms 1: 50 ms
3	Time length from CML ON to CNG transmission	0: 2 sec. 1: 4 sec.
4	Time length from CML ON to CED transmission (except for facsimile-to-telephone switching)	0: 0.5 sec. 1: 2 sec.
5 6	No. of training retries	No. 5 6 0 0: 1 time 0 1: 2 times 1 0: 3 times 1 1: 4 times
7	Encoding system (Compression)	MR 0: Allowed 1: Not allowed
8		MMR 0: Allowed 1: Not allowed

- Selector 2: Time length from transmission of the last dial digit to CML ON

This selector sets the time length from when the machine transmits the last dial digit until the CML relay comes on.

- Selector 3: Time length from CML ON to CNG transmission

This selector sets the time length until the machine transmits a CNG after it turns on the CML relay.

- Selector 4: Time length from CML ON to CED transmission

This selector sets the time length until the machine transmits a CED after it turns on the CML relay. This setting does not apply to switching between facsimile and telephone.

- Selectors 5 and 6: No. of training retries

These selectors set the number of training retries to be repeated before automatic fallback.

- Selectors 7 and 8: Encoding system (Compression)

This selector determines whether or not to allow the use of the MR/MMR coding system.

< WSW11 >

Selector No.	Function	Setting and Specifications
1 2	Busy tone frequency band control	No. 1 2 0 0: Narrows by 10 Hz 0 1: Initial value 1 0: Widens by 10 Hz 1 1: Widens by 10 Hz
3	ON/OFF time length ranges for busy tone (More than one setting allowed)	1: 250-750/250-750 ms
4		1: 400-600/400-600 ms
5		1: 175-440/175-440 ms
6		1: 100-1000/17-660 ms
7		1: 110-410/320-550 ms
8		1: 100-660/100-660 ms

Note:

- WSW11 is not applicable in those countries where no busy tone detection is supported.
- The setting of WSW11 is effective only when selectors 5 and 6 on WSW05 are set to "0, 1" or "1, 1" (Busy tone detection).

- Selectors 1 and 2: Busy tone frequency band control

These selectors set the frequency band for busy tone to be detected.

- Selectors 3 through 8: ON/OFF time length ranges for busy tone

These selectors set the ON and OFF time length ranges for busy tone to be detected. If more than one selector is set to "1," the ranges become wider. For example, if selectors 4 and 5 are set to "1," the ON and OFF time length ranges are from 175 to 600 ms.

< WSW12 >

Selector No.	Function	Setting and Specifications
1 2	Min. detection period required for interpreting incoming calling signal (CI) as OFF	No. 1 2 0 0: 1500 ms 0 1: 500 ms 1 0: 700 ms 1 1: 900 ms
3 4	Max. detection period for incoming calling signal (CI) being OFF	No. 3 4 0 0: 6 sec. 0 1: 7 sec. 1 0: 9 sec. 1 1: 11 sec.
5 6	Min. detection period required for acknowledging incoming calling signal (CI) as ON	No. 5 6 0 0: 800 ms (1000 ms*) 0 1: 200 ms 1 0: 250 ms 1 1: 150 ms
7	Line connection timing	0: Ringer-OFF period 1: Ringer-ON period
8	Not used.	

*1000 ms in Chinese models.

- Selectors 1 through 4: Min. detection period required for interpreting incoming calling signal (CI) as OFF

Max. detection period for incoming calling signal (CI) being OFF

If the machine detects the OFF state of a CI signal for the period greater than the value set by selectors 1 and 2 and less than the value set by selectors 3 and 4, it interprets the CI signal as OFF.

- Selectors 5 and 6: Min. detection period required for acknowledging incoming calling signal (CI) as ON

These selectors set the period required to make the machine acknowledge itself to be called. That is, if the machine continuously detects a CI signal with the frequency set by selectors 1 through 4 on WSW14 during the period set by these selectors 5 and 6, then it acknowledges the call.

- Selector 7: Line connection timing

If a line is connected in a ringer-ON period, FAX models equipped with SDAA circuits may malfunction due to the ringer voltage. To make the line connection stable, this selector should be set to "0" so that a line is connected in a ringer-OFF period.

< WSW13 >

Selector No.	Function	Setting and Specifications
1 2	Cable equalizer	No. 1 2 0 0: 0 km 0 1: 1.8 km 1 0: 3.6 km 1 1: 5.6 km
3 4	Reception level	No. 3 4 0 0: -43 dBm 0 1: -47 dBm 1 0: -49 dBm 1 1: -51 dBm
5 8	Modem attenuator	0: 0 dB 0: 8 dB 0: 0 dB 0: 4 dB 0: 0 dB 0: 2 dB 0: 0 dB 0: 1 dB

Note:

The modem should be adjusted according to the user's line conditions.

- Selectors 1 and 2: Cable equalizer

These selectors are used to improve the pass-band characteristics of analogue signals on a line. Attenuation in the high-band frequency is greater than in the low-band frequency.

Set these selectors according to the distance from the telephone switchboard to the machine.

- Selectors 3 and 4: Reception level

These selectors set the optimum receive signal level.

- Selectors 5 through 8: Modem attenuator

These selectors are used to adjust the transmitting level attenuation of the modem when the reception level at the remote station is improper due to line loss. This function applies for G3 protocol signals.

Setting two or more selectors to "1" produces addition of attenuation assigned to each selector.

If selector 8 on WSW23 is set to "0," this setting is so limited that 10 dB (1 dB in France) or higher setting only is effective.

Note that in Japan and China, 9 dB or higher and 2 dB or higher settings only are effective, respectively, regardless of whether selector 8 on WSW23 is set to "0."

< WSW14 >

Selector No.	Function	Setting and Specifications
1 2	Frequency band selection (lower limit) for incoming calling signal (CI)	No. 1 2 0 0: 13 Hz 0 1: 15 Hz 1 0: 23 Hz 1 1: 20 Hz
3 4	Frequency band selection (upper limit) for incoming calling signal (CI)	No. 3 4 0 0: 30 Hz 0 1: 55 Hz 1 0: 70 Hz 1 1: 200 Hz
5 8	No. of rings in AUTO ANS mode	No. 5 6 7 8 0 0 0 0: Fixed to once 0 0 0 1: 1 to 6 times 0 0 1 0: 1 to 8 times 0 0 1 1: 2 to 8 times 0 1 0 0: 1 to 2 times 0 1 0 1: 1 to 3 times 0 1 1 0: 1 to 4 times 0 1 1 1: 1 to 5 times 1 0 0 0: 2 to 3 times 1 0 0 1: 2 to 4 times 1 0 1 0: 2 to 5 times 1 0 1 1: 2 to 6 times 1 1 0 0: 1 to 10 times 1 1 0 1: 2 to 10 times 1 1 1 0: 3 to 5 times 1 1 1 1: 4 to 10 times

- Selectors 1 through 4: Frequency band selection for incoming calling signal (CI)

These selectors are used to select the frequency band of CI for activating the AUTO ANS facility.

In the French models, if the user sets the PBX to OFF from the control panel, the setting made by selectors 1 and 2 will take no effect and the frequency's lower limit will be fixed to 32 Hz. (Even if the setting made by these selectors does not apply, it will be printed on the configuration list.)

- Selectors 5 through 8: No. of rings in AUTO ANS mode

These selectors set the number of rings to initiate the AUTO ANS facility.

< WSW15 >

Selector No.	Function	Setting and Specifications
1 2	Redial interval	No. 1 2 0 0: 5 min. 0 1: 1 min. 1 0: 2 min. 1 1: 3 min.
3 6	No. of redialings	No. 3 4 5 6 0 0 0 0: 16 times 0 0 0 1: 1 times 0 0 1 0: 2 times 0 0 1 1: 3 times 1 1 1 1: 15 times
7	(Not used.)	
8	CRP option	0: Disable 1: Enable

- Selectors 1 through 6: Redial interval and No. of redialings

The machine redials by the number of times set by selectors 3 through 6 at intervals set by selectors 1 and 2.

- Selector 8: CRP option

If a command error occurs in the machine (calling station), the machine usually waits for three seconds and then makes a retry three times. This CRP option is a request command that can be sent from the called station for requesting the calling station to retry the failed command immediately.

< WSW16 >

Selector No.	Function	Setting and Specifications
1	Not used.	
2	ITU-T (CCITT) superfine recommendation	0: OFF 1: ON
3 6	Not used.	
7	Max. document length limitation	0: 400 cm 1: 90 cm
8	Stop/Exit button pressed during reception	0: Not functional 1: Functional

Note:

Selector 7 is applicable to models equipped with ADF units.

- Selector 2: ITU-T (CCITT) superfine recommendation

If this selector is set to "1," the machine communicates in ITU-T (CCITT) recommended superfine mode (15.4 lines/mm). If it is set to "0," it communicates in native superfine mode.

- Selector 7: Max. document length limitation

This selector is used to select the maximum length of a document to be sent.

- Selector 8: Stop/Exit button pressed during reception

If this selector is set to "1," pressing the **Stop/Exit** button can stop the current receiving operation. The received data will be lost.

< WSW17 >

Selector No.	Function	Setting and Specifications
1 2	Off-hook alarm	No. 1 2 0 0: No alarm 0 1: Always valid 1 0: Valid except when ' call reservation' is selected. 1 1: Valid except when ' call reservation' is selected.
3 4	Not used.	
5	Calendar clock type	0: U.S.A. type 1: European type
6	Not used.	
7	Non-ring reception	0: OFF 1: ON
8	Not used.	

- Selectors 1 and 2: Off-hook alarm

These selectors activate or deactivate the alarm function which sounds an alarm when the communication is completed with the handset being off the hook.

- Selector 5: Calendar clock type

If this selector is set to "0" (USA), the MM/DD/YY hh:mm format applies; if it is set to "1" (Europe), the DD/MM/YY hh:mm format applies: DD is the day, MM is the month, YY is the last two digits of the year, hh is the hour, and mm is the minute.

- Selector 7: Non-ring reception

Setting this selector to "1" makes the machine receive calls without ringer sound if the Ring Delay is set to 0.

< WSW18 >

Selector No.	Function	Setting and Specifications
1	Not used.	
2 3	Detection enabled time for CNG and no tone	No. 2 3 0 0: 40 sec. 0 1: 0 sec. (No detection) 1 0: 5 sec. 1 1: 80 sec.
4 5	Not used.	
6	Registration of station ID	0: Permitted 1: Prohibited
7 8	Tone sound monitoring	No. 7 8 0 0: No monitoring 0 1: No monitoring 1 0: Up to phase B at the calling station only 1 1: All transmission phases both at the calling and called stations

- Selectors 2 and 3: Detection enabled time for CNG and no tone

After the line is connected via the external telephone or by picking up the handset of the machine, the machine can detect a CNG signal or no tone for the time length specified by these selectors. The setting specified by these selectors becomes effective only when selector 8 on WSW20 is set to "1."

- Selector 6: Registration of station ID

Setting this selector to "0" permits the registration of station ID for Austrian and Czech models.

- Selectors 7 and 8: Tone sound monitoring

These selectors set monitoring specifications of the tone sound inputted from the line.

< WSW19 >

Selector No.	Function	Setting and Specifications
1 3	First transmission speed choice for fallback	No. 1 2 3 No. 4 5 6 0 0 0: 2,400 bps 0 0 1: 4,800 bps 0 1 0: 7,200 bps 0 1 1: 9,600 bps
4 6	Last transmission speed choice for fallback	1 0 0: 12,000 bps 1 0 1: 14,400 bps 1 1 0: 14,400 bps 1 1 1: 14,400 bps
7	V.34 mode (Not used.)	0: Permitted 1: Prohibited
8	V.17 mode	0: Permitted 1: Prohibited

Note:

Selector 7 takes effect only in models supporting V.34 mode.

- Selectors 1 through 6: First and last choices of transmission speed for fallback

These selectors are used to set the MODEM speed range. With the first transmission speed choice specified by selectors 1 through 3, the machine attempts to establish the transmission link via the MODEM. If the establishment fails, the machine automatically steps down to the next lowest speed and attempts to establish the transmission link again. The machine repeats this sequence while stepping down the transmission speed to the last choice specified by selectors 4 through 6.

If the MODEM always falls back to a low transmission speed (e.g., 4,800 bps), set the first transmission speed choice to the lower one (e.g., modify it from 12,000 bps to 7,200 bps) in order to deactivate the high-speed MODEM function and reduce the training time for shorter transmission time.

Generally, to save the transmission time, set the last transmission speed choice to a higher one.

- Selector 7: V.34 mode (Not used.)

If this selector is set to "0," selectors 5 through 8 on the WSW38 through WSW40 and on WSW41, will become effective.

< WSW20 >

Selector No.	Function	Setting and Specifications
1	EP* tone prefix	0: OFF 1: ON
2	Overseas communications mode (Reception)	0: 2100 Hz 1: 1100 Hz
3	Overseas communications mode (Transmission)	0: OFF 1: Ignores DIS once.
4 5	Min. time length from reception of CFR to start of transmission of video signals	No. 4 5 0 0: 100 ms 0 1: 200 ms 1 0: 300 ms 1 1: 400 ms
6 7	At CNG detection, elimination of chattering noise	No. 6 7 0 0: Yes, at both ON/OFF timings 0 1: Yes, at OFF timing 1 0: No 1 1: No
8	Limitation on CNG detection	0: OFF 1: ON

* EP: Echo protection

Note:

Selectors 6 and 7 are applicable to models equipped with SDAA circuits.

- Selector 1: EP tone prefix

Setting this selector to "1" makes the machine transmit a 1700 Hz echo protection (EP) tone immediately preceding training in V.29 modulation system to prevent omission of training signals.

Prefixing an EP tone is useful when the machine fails to transmit at the V.29 modem speed and always has to fall back to 4800 bps transmission.

The setting made by this selector takes effect only when the Overseas Mode is set to ON.

- Selectors 2 and 3: Overseas communications mode

These selectors should be used if the machine malfunctions in overseas communications. According to the communications error state, select the signal specifications.

Setting selector 2 to "1" allows the machine to use 1100 Hz CED signal instead of 2100 Hz in receiving operation. This prevents malfunctions resulting from echoes, since the 1100 Hz signal does not disable the echo suppressor (ES) while the 2100 Hz signal does.

Setting selector 3 to "1" allows the machine to ignore a DIS signal sent from the called station once in sending operation. This operation suppresses echoes since the first DIS signal immediately follows a 2100 Hz CED (which disables the ES) so that it is likely to be affected by echoes in the disabled ES state. However, such a disabled ES state will be removed soon so that the second and the following DIS signals are not susceptible to data distortion due to echoes. Note that some models when called may cause error by receiving a self-outputted DIS.

The setting made by selector 3 takes effect only when the Overseas Communications Mode is set to ON. (The setting made by selector 2 is always effective.)

- Selectors 8: Limitation on CNG detection

If this selector is set to “1,” the machine detects a CNG signal according to the condition preset by selectors 2 and 3 on WSW18 after a line is connected. If it is set to “0,” the machine detects a CNG signal as long as the line is connected.

< WSW21 >

Selector No.	Function	Setting and Specifications
1 5	Max. waiting time for voice signal	No. 1 2 3 4 5 0 0 0 0 0: No detection 0 0 0 0 1: 1 sec. 0 0 0 1 0: 2 sec. 0 0 0 1 1: 3 sec. 0 0 1 1 0: 6 sec. (Default) 1 1 1 1 1: 31 sec.
6 7	Taping the call	No. 6 7 0 0: Enable (signaling for (A) U.S.A.) (B) 0 1: Enable (signaling for (C) countries except U.S.A.) (D) 1 0: Enable (without signaling) 1 1: Disable
8	Erasure of message stored in the memory after the message transfer	0: Yes 1: No

Note:

- Selectors 1 through 5 are applicable to models equipped with ICM recorders.
- Selectors 6 through 8 are applicable to models equipped with TADs.

- Selectors 1 through 5: Max. waiting time for voice signal

In the TAD mode, the machine waits for voice signal for the time length specified by these selectors before it automatically shifts to the facsimile message receive mode or disconnects the line.

- Selectors 6 and 7: Taping the call

These selectors select whether or not to tape the call. Setting them to “1, 0” enables taping the call without signaling to the calling station that the call is being taped.

- Selector 8: Erasure of message stored in the memory after the message transfer

Setting this selector to “0” will erase the message recorded in the memory after the document retrieval feature transfers the message.

< WSW22 >

Selector No.	Function	Setting and Specifications	
1	ECM* in sending	0: Valid	1: Invalid
2	ECM* in receiving	0: Valid	1: Invalid
3	Call Waiting Caller ID	0: Displayed	1: Not displayed
4	Not used.		
5	Acceptable TCF bit error rate (%) (Only at 4800 bps) (Not used.)	0: 0 %	1: 8 %
6		0: 0 %	1: 4 %
7		0: 0 %	1: 2 %
8		0: 0 %	1: 1 %

* ECM: Error correction mode

Note:

- Selector 3 is applicable to the American models only.
- Selectors 5 through 8 are applicable to the Chinese, Taiwanese and Asian models only.

- Selector 3: Call Waiting Caller ID

Setting this selector to "0" allows the user to decide whether or not to interrupt the current call when a new call comes in. If Call Waiting Caller ID service is available in the area and the user subscribes to it, he/she can see information about his/her incoming call on the LCD.

- Selectors 5 through 8: Acceptable TCF bit error rate (%) (Not used.)

Setting two or more selectors to "1" produces addition of percent assigned to each selector. If you set selectors 7 and 8 to "1," the acceptable TCF bit error rate will be 3%.

< WSW23 >

Selector No.	Function	Setting and Specifications
1	Starting point of training check (TCF)	0: 0 From the head of a series of zeros 1: From any arbitrary point
2 3	Allowable training error rate	No. 2 3 0 0: 0 % 0 1: 0.5 % 1 0: 1 % 1 1: 2 %
4 5		No. 4 5 0 0: 16 % 0 1: 14% 1 0: 10 % 1 1: 8 %
6 7	Not used.	
8	Limitation of attenuation level	0: Yes 1: No

Note:

Selector 8 is not applicable to the French models.

- Selector 1: Starting point of training check (TCF)

At the training phase of receiving operation, the called station detects for 1.0 second a training check (TCF) command, a series of zeros which is sent from the calling station for 1.5 seconds to verify training and give the first indication of the acceptability of the line.

This selector sets the starting point from which the called station should start counting those zeros. If this selector is set to "0," the called station starts counting zeros 100 ms after the head of a series of zeros is detected.

If it is set to "1," the called station starts counting zeros upon detection of 10-ms successive zeros 50 ms after the head of a series of zeros is detected. In this case, if the detection of 10-ms successive zeros is too late, the data counting period will become less than 1.0 second, making the called station judge the line condition unacceptable.

- Selectors 2 and 3: Allowable training error rate

The called station checks a series of zeros gathered in training (as described in Selector 1) according to the allowable training error rate set by these selectors. If the called station judges the line condition to be accepted, it responds with CFR; if not, it responds with FTT.

- Selectors 4 and 5: Decoding error rate for transmission of RTN

The machine checks the actual decoding errors and then transmits an RTN according to the decoding error rate (Number of lines containing an error per page ÷ Total number of lines per page) set by these selectors.

- Selector 8: Limitation of attenuation level

Setting this selector to "0" limits the transmitting level of the modem to 4 dB. This setting has priority over the settings selected by WSW02 (selectors 5 through 8) and WSW13 (selectors 5 through 8).

< WSW24 >

Selector No.	Function	Setting and Specifications	
1 2	Maximum OGM recording time	No. 1 0 0 1 1	2 0: 15 sec. 1: 20 sec. 0: 30 sec. 1: 50 sec.
3 4	Time length from CML ON to start of pseudo ring backtone transmission	No. 3 0 0 1 1	4 0: 4 sec. 1: 3 sec. 0: 2 sec. 1: 1 sec.
5 8	Attenuator for playback of ICM/OGM to the line	0: 0 dB 0: 0 dB 0: 0 dB 0: 0 dB	1: 8 dB 1: 4 dB 1: 2 dB 1: 1 dB

- Selectors 1 and 2: Maximum OGM recording time

These selectors set the allowable maximum recording time for an OGM.

- Selectors 3 and 4: Time length from CML ON to start of pseudo ring backtone transmission

These selectors set the length of time from CML-ON up to the start of pseudo ring backtone transmission.

In models with OGM facilities, the settings made by these selectors also apply to the length of time from CML-ON up to the start of OGM transmission.

- Selectors 5 through 8: Attenuator for playback of ICM/OGM to the line

Setting two or more selectors to "1" produces addition of attenuation assigned to each selector.

This setting is not limited by selector 8 on WSW23.

< WSW25 >

Selector No.	Function	Setting and Specifications
1 2	External TAD no-tone detection start delay time	No. 1 2 0 0: 0 sec. 0 1: 8 sec. 1 0: 16 sec. 1 1: 24 sec.
3 4	External TAD no-tone detection level	No. 3 4 0 0: -43 dB (A) 0 1: -46 dB (B) 1 0: -49 dB (C) 1 1: -51 dB (D)
5 7	Pause between paging number and PIN	No. 5 6 7 0 0 0: 2 sec. 0 0 1: 4 sec. 0 1 0: 6 sec. 0 1 1: 8 sec. 1 0 0: 10 sec. 1 0 1: 12 sec. 1 1 0: 14 sec. 1 1 1: 16 sec.
8	Not used.	

Note:

- Selectors 1 through 4 are not applicable in cases of models designed for the US market, models not equipped with a function of detection for no tone with external TAD, nor for models equipped with the Rockwell modem V24.
- Selectors 5 through 7 are applicable to the U.S.A. models only.

- Selectors 1 and 2: External TAD no-tone detection start delay time

Valid only for the external TAD mode. This machine will delay the start of detection for no tone by the length of time set by selectors 1 and 2.
The sum of the detection delay time setting and the waiting time for no-tone detection setting by selectors 1 through 5 of WSW21 must be within 40 seconds or less.

- Selectors 3 and 4: External TAD no-tone detection level

These selectors set the no-tone detection level in the external TAD mode.

- Selectors 5 through 7: Pause between paging number and PIN

These selectors set the pause time between a telephone number being paged and PIN (personal identification number) for the paging feature.

< WSW26 >

Selector No.	Function	Setting and Specifications
1 2	Not used.	
3	Dialing during document reading into the temporary memory in in-memory message transmission	0: Disable 1: Enable
4 5	No. of CNG cycles to be detected (when the line is connected via the external telephone except in the external TAD mode or via the built-in telephone)	No. 4 5 0 0: 0.5 (A) 0 1: 1 (B) 1 0: 1.5 (C) 1 1: 2 (D)
6 7	No. of CNG cycles to be detected (when the line is connected via the external telephone in the external TAD mode, via the built-in telephone in the TAD mode, or via the machine in the automatic reception of the F/T mode)	No. 6 7 0 0: 0.5 (A) 0 1: 1 (B) 1 0: 1.5 (C) 1 1: 2 (D)
8	Not used.	

- Selector 3: Dialing during document reading into the temporary memory in in-memory message transmission

If this selector is set to "0," the machine waits for document reading into the memory to complete and then starts dialing. This enables the machine to list the total number of pages in the header of the facsimile message.

- Selectors 4 and 5: No. of CNG cycles to be detected (when the line is connected via the external telephone except in the external TAD mode or via the built-in telephone)

The machine interprets a CNG as an effective signal if it detects the CNG by the number of cycles specified by these selectors when the line is connected via the external telephone except in the external TAD mode or via the built-in telephone.

- Selectors 6 and 7: No. of CNG cycles to be detected (when the line is connected via the external telephone in the external TAD mode, via the built-in telephone in the TAD mode, or via the machine in the automatic reception of the F/T mode)

The machine interprets a CNG as an effective signal if it detects the CNG by the number of cycles specified by these selectors when the line is connected via the external telephone in the external TAD mode, via the built-in telephone in the TAD mode, or via the machine in the automatic reception of the F/T mode.

< WSW27 >

Selector No.	Function	Setting and Specifications	
1	Not used.		
2	Ringer OFF setting	0: Yes	1: No
3	Automatic playback of OGM when switched to the TAD mode	0: No	1: Yes
4	Detection of distinctive ringing pattern	0: Yes	1: No
5	Not used.		
6	Recording quality	0: Normal	1: High
7	Recording time for high recording quality	0: Short (9.6 kbps)	1: Long (8.8 kbps)
8	Not used.		

Note:

Selectors 4 and 5 are applicable to the U.S.A. models only.

- Selector 2: Ringer OFF setting

This selector determines whether or not the ringer can be set to OFF.

- Selector 3: Automatic playback of OGM when switched to the TAD mode

This selector determines whether or not to automatically play back an OGM the moment the machine switches to the TAD mode.

- Selectors 4: Detection of distinctive ringing pattern

If this selector is set to "1," the machine detects only the number of rings; if it is set to "0," the machine detects the number of rings and the ringing time length to compare the detected ringing pattern with the registered distinctive one.

- Selector 6: Recording quality

This selector determines the recording quality for the OGM and ICM. Selecting "1" (High) increases the quality, sacrificing the recording time.

- Selector 7: Recording time for high recording quality

This setting takes effect when selector 6 is set to "1" (High). Setting this selector to "0" (Short) further increases the recording quality, sacrificing the recording time. The recording quality and time to be applied when this selector is set to "1" (Long) are higher and shorter than the ones to be applied when selector 6 is set to "0" (Normal).

The recording quality and time determined by this selector being set to "1" (Long) are higher and shorter than the ones determined by selector 6 being set to "0" (Normal).

< WSW28 >

Selector No.	Function	Setting and Specifications
1 3	Transmission level of DTMF high-band frequency signal	No. 1 2 3 0 0 0: 0 dB 0 0 1: +1 dB 0 1 0: +2 dB 0 1 1: +3 dB 1 0 0: 0 dB 1 0 1: -1 dB 1 1 0: -2 dB 1 1 1: -3 dB
4 6	Transmission level of DTMF low-band frequency signal	No. 4 5 6 0 0 0: 0 dB 0 0 1: +1 dB 0 1 0: +2 dB 0 1 1: +3 dB 1 0 0: 0 dB 1 0 1: -1 dB 1 1 0: -2 dB 1 1 1: -3 dB
7 8	Not used.	

- Selectors 1 through 6: Transmission level of DTMF high-/low-band frequency signal

These selectors are intended for the manufacturer who tests the machine for the Standard. Never access them.

< WSW29 >

Selector No.	Function	Setting and Specifications
1 3	Compression threshold level for voice signals inputted via the telephone line in the built-in TAD operation	No. 1 2 3 0 0 0: -47.0 dBm (A) 0 0 1: -48.5 dBm (B) 0 1 0: -50.0 dBm (C) 0 1 1: -51.5 dBm (D) 1 0 0: -53.0 dBm (E) 1 0 1: -54.5 dBm (F) 1 1 0: -56.0 dBm (G) 1 1 1: OFF (H)
4 6	Compression threshold level for voice signals inputted via the handset in the built-in TAD operation	No. 4 5 6 0 0 0: -44.0 dBm (A) 0 0 1: -45.5 dBm (B) 0 1 0: -47.0 dBm (C) 0 1 1: -48.5 dBm (D) 1 0 0: -50.0 dBm (E) 1 0 1: -51.5 dBm (F) 1 1 0: -53.0 dBm (G) 1 1 1: OFF (H)
7	Impedance switching control in pulse dialing	0: OFF 1: ON
8	Prompt beep when the memory area for the activity report becomes full	0: No 1: Yes

Note:

- Selectors 1 through 6 are applicable to models equipped with built-in TADs.
- Selectors 7 and 8 are applicable only to the European versions.

- Selectors 1 through 6: Compression threshold level for voice signals inputted via the telephone line in the built-in TAD operation

If voice signals inputted via the telephone line are below the level specified by these selectors, the TAD interprets those received voice signals as no signal, compressing the recording time.

- Selector 8: Prompt beep for activity report

This selector determines whether or not to beep if the memory area for the activity report becomes full, for prompting you to print out the report. (Printing it out will clear the memory area.)

< WSW30 >

Selector No.	Function	Setting and Specifications																																													
1 3	Dial tone/busy tone detection level during recording of ICM (Not used.)	<table border="0"> <tr> <td>No.</td> <td>1</td> <td>2</td> <td>3</td> <td></td> </tr> <tr> <td></td> <td>0</td> <td>0</td> <td>0:</td> <td>-38.0 dBm (A)</td> </tr> <tr> <td></td> <td>0</td> <td>0</td> <td>1:</td> <td>-39.5 dBm (B)</td> </tr> <tr> <td></td> <td>0</td> <td>1</td> <td>0:</td> <td>-41.0 dBm (C)</td> </tr> <tr> <td></td> <td>0</td> <td>1</td> <td>1:</td> <td>-42.5 dBm (D)</td> </tr> <tr> <td></td> <td>1</td> <td>0</td> <td>0:</td> <td>-44.0 dBm (E)</td> </tr> <tr> <td></td> <td>1</td> <td>0</td> <td>1:</td> <td>-45.5 dBm (F)</td> </tr> <tr> <td></td> <td>1</td> <td>1</td> <td>0:</td> <td>-47.0 dBm (G)</td> </tr> <tr> <td></td> <td>1</td> <td>1</td> <td>1:</td> <td>-48.5 dBm (H)</td> </tr> </table>	No.	1	2	3			0	0	0:	-38.0 dBm (A)		0	0	1:	-39.5 dBm (B)		0	1	0:	-41.0 dBm (C)		0	1	1:	-42.5 dBm (D)		1	0	0:	-44.0 dBm (E)		1	0	1:	-45.5 dBm (F)		1	1	0:	-47.0 dBm (G)		1	1	1:	-48.5 dBm (H)
No.	1	2	3																																												
	0	0	0:	-38.0 dBm (A)																																											
	0	0	1:	-39.5 dBm (B)																																											
	0	1	0:	-41.0 dBm (C)																																											
	0	1	1:	-42.5 dBm (D)																																											
	1	0	0:	-44.0 dBm (E)																																											
	1	0	1:	-45.5 dBm (F)																																											
	1	1	0:	-47.0 dBm (G)																																											
	1	1	1:	-48.5 dBm (H)																																											
4 6	Not used.																																														
7	Scanning magnification adjusting function	0: Enable 1: Disable																																													
8	Not used.																																														

Note:

Selectors 1 through 3 are applicable to models equipped with internal TADs.

-Selectors 1 through 3: Dial tone/busy tone detection level during recording of ICM (Not used.)

If the machine (called station) detects dial tone (400 Hz continuously) or busy tone (400 Hz intermittently) exceeding the detection level specified by these selectors for the period specified by selectors 1 through 4 on WSW35, then it interprets the calling station as being disconnected. The machine stops TAD recording and disconnects the line.

< WSW31 >

Selector No.	Function	Setting and Specifications
1	Not used.	
2	Default reduction rate for failure of automatic reduction during recording	0: 100 % 1: 75 %
3	Not used.	
4	(Do not disturb this selector.)	
5	Minimum ON and OFF duration of ringer signals effective in distinctive ringing	0: 130 ms 1: 90 ms
6 7	Not used.	
8	Drum life indication	0: No 1: Yes

Note:

Selector 5 is applicable only to the U.S.A. models.

- Selector 2: Default reduction rate for failure of automatic reduction during recording

This selector sets the default reduction rate to be applied if the automatic reduction function fails to record one-page data sent from the calling station in a single page of the current recording paper.

If it is set to "0," the machine records one-page data at full size (100%) without reduction; if it is set to "1," the machine records it at 70% size.

- Selector 5: Minimum ON and OFF duration of ringer signals effective in distinctive ringing

The ringer pattern consists of short and long rings, e.g., short-short-long rings. This selector sets the minimum ON and OFF duration of ringer signals that are required for the machine to interpret ringer signals as being ON or OFF. This is to prevent components of a ringer pattern from being misinterpreted due to chattering in distinctive ringing.

The machine monitors ringer signals at 10-ms intervals. If the signal is ON, the machine counts +1; if it is OFF, it counts -1. If the counter increments up to +5 or +13 when this selector is set to "1" (90 ms) or "0" (130 ms), respectively, the machine interprets the current signal as being ON.

If the counter returns to zero, the machine interprets the signal as being OFF.

If the Distinctive Ring is set to OFF, this selector is not effective.

< WSW32 >

Selector No.	Function	Setting and Specifications
1 4	Not used.	
5 6	Default resolution	No. 5 6 0 0: Standard 0 1: Fine 1 0: Super fine 1 1: Photo
7 8	Default contrast	No. 7 8 0 0: Automatic 0 1: Automatic 1 0: Super light 1 1: Super dark

- Selectors 5 and 6: Default resolution

These selectors set the default resolution which applies when the machine is turned on or completes a transaction.

- Selectors 7 and 8: Default contrast

These selectors set the default contrast which applies when the machine is turned on or completes a transaction.

< WSW33 >

Selector No.	Function	Setting and Specifications
1 3	Detection threshold level of "no tone" during recording of ICM	No. 1 2 3 0 0 0: -48 dBm (A) 0 0 1: -50 dBm (B) 0 1 0: -52 dBm (C) 0 1 1: -54 dBm (D) 1 0 0: -56 dBm (E) 1 0 1: -58 dBm (F) 1 1 0: -60 dBm (G) (Default) 1 1 1: -62 dBm (H)
4 5	FAX receiving speed to be kept within the transmission speed limit to the PC (Not used.)	No. 4 5 0 0: 14,400 bps 0 1: 12,000 bps 1 0: 9,600 bps 1 1: 7,200 bps
6	Report output of polled transmission requests	0: Yes 1: No
7 8	Comfortable noise level (Not used.)	No. 7 8 0 0: OFF 0 1: Low (A) 1 0: Medium (B) 1 1: High (C)

Note:

Selectors 1 through 3 are applicable to models equipped with internal TADs.

- Selectors 1 through 3: Detection threshold level of "no tone" during recording of ICM

If the tone level during recording of ICM is less than the threshold setting made by these selectors, the tone is interpreted as "no tone". When the "no tone" state is kept for the period specified by selectors 1 through 5 on WSW21, the machine disconnects the line.

- Selectors 4 and 5: FAX receiving speed to be kept within the transmission speed limit to the PC (Not used.)

To transmit FAX data being received from other machine to the connected PC, you may need to keep the FAX receiving speed within the transmission speed limit specified for the PC. In an initial negotiation sequence for transmission, the machine responds to the calling station with the allowable FAX receiving speed specified by these selectors.

- Selectors 7 and 8: Comfortable noise level (Not used.)

These selectors set the level of noise to be added during playing-back of voice signals recorded with no-signal compression. If they are set to "0, 0," no noise will be added.

< WSW34 >

Selector No.	Function	Setting and Specifications
1 3	Erasing time length of ICM tone recorded preceding the tone detection starting point in the case of automatic line disconnection due to no voice signal received	No. 1 2 3 0 0 0: 0 sec. 0 0 1: 1 sec. 0 1 0: 2 sec. 0 1 1: 3 sec. 1 0 0: 4 sec. 1 0 1: 5 sec. 1 1 0: 6 sec. 1 1 1: 7 sec.
4 5	No. of CNG cycles to be detected (when the line is connected via the external telephone in the external TAD mode or via the machine in F/T mode)	No. 4 5 0 0: 0.5 (A) 0 1: 1 (B) 1 0: 1.5 (C) 1 1: 2 (D)
6 7	Number of DTMF tone signals for inhibiting the detection of CNG during external TAD operation	No. 6 7 0 0: 3 0 1: 2 1 0: 1 1 1: OFF
8	Not used.	

Note:

Selectors 1 through 5 are applicable to models equipped with built-in TADs.

- Selectors 1 through 3: Erasing time length of ICM tone recorded preceding the tone detection starting point in the case of automatic line disconnection due to no voice signal received

If the machine has disconnected the line after detection of disconnection tone in ICM recording, it erases tone recorded preceding the tone detection starting point for the time length set by these selectors.

- Selectors 4 and 5: No. of CNG cycles to be detected (when the line is connected via the external telephone in the external TAD mode or via the machine in F/T mode)

The machine interprets a CNG as an effective signal if it detects a CNG signal by the number of cycles specified by these selectors when the line is connected via the external telephone in the external TAD mode or via the machine in F/T mode.

- Selectors 6 and 7: Number of DTMF tone signals for inhibiting the detection of CNG during external TAD operation

If the machine receives this specified number of DTMF tone signals during external TAD operation, it will not detect CNG afterwards.

If these selectors are set to "1, 1," the CNG detection will not be inhibited.

< WSW35 >

Selector No.	Function	Setting and Specifications
1 4	Max. detection period of dial tone/busy tone during recording of ICM	No. 1 2 3 4 0 0 0 0: No detection 0 0 0 1: 1 sec. 0 0 1 0: 2 sec. 0 1 0 0: 4 sec. 1 1 1 1: 15 sec.
5 8	Not used.	

Note:

Selectors 1 through 4 are applicable to models equipped with internal TADs.

- Selectors 1 through 4: Max. detection period of dial tone/busy tone during recording of ICM

If the machine (called station) detects dial tone or busy tone exceeding the detection level specified by selectors 1 through 3 on WSW30 for the period specified by these selectors, then it disconnects the line.

< WSW36 >

Selector No.	Function	Setting and Specifications
1	ECP mode* (Not used.)	0: ON 1: OFF
2	Recovery from Inactive PC Interface (Not used.)	0: Disable 1: Enable
3	PC Power-off Recognition Time (Not used.)	0: Normal 1: Long
4	Not used.	
5	Escape from phase C	0: Yes 1: No
6 8	Extension of incoming calling signal (CI) frequency band specified by selectors 1 through 4 on WSW14	No. 6 7 8 0 0 0: 0 (Ignored) 0 0 1: 4 (448 Hz) 0 1 0: 8 (244 Hz) 0 1 1: 12 (162 Hz) 1 0 0: 16 (122 Hz) 1 0 1: 20 (97 Hz) 1 1 0: 24 (81 Hz) 1 1 1: 28 (69 Hz)

*ECP (Enhanced Capabilities Port)

Note:

Selectors 2 and 3 will become operative if selectors 1 and 2 of WSW46 are set to "monitor" the PC power ON/OFF state.

- Selector 1: ECP mode (Not used.)

The ECP mode enhances the normal bidirectional communications between the machine and the connected PC for higher transmission speed.

- Selector 2: Recovery from Inactive PC Interface (Not used.)

If the machine recognizes via the STB signal line that the connected PC is powered off, it will turn the PC interface outputs Low to protect the PC from hazards that could be caused by weak electric current accidentally flown from the machine.

This selector determines whether or not the machine should recover from the inactive PC interface to normal interfacing state upon receipt of data from the PC.

- Selector 3: PC Power-off Recognition Time (Not used.)

This selector sets the time length from when the machine detects the PC powered off until it recognizes the detected state as power-off.

If selector 2 is set to "0," it is recommended that selector 3 be set to "1"; otherwise, the machine may mistakenly detect PC powered off.

- Selector 5: Escape from phase C

This selector determines whether or not the machine will escape from phase C when it detects an RTC (Return to Control) in non-ECM mode or an RCP (Return to Control Partial page) in ECM mode.

- Selectors 6 through 8: Extension of incoming calling signal (CI) frequency band specified by selectors 1 through 4 on WSW14

At the start of reception, if the machine detects the frequency of a CI signal specified by selectors 1 through 4 on WSW14, it starts the ringer sounding. However, the machine may fail to detect the CI signal normally due to noise superimposed at the time of reception. To prevent it, use selectors 6 through 8 on WSW36.

If the machine detects higher frequencies than the setting made here, it regards them as noise and interprets the detecting state as being normal, allowing the ringer to keep sounding according to the preset number of ringers (until it starts automatic reception of FAX data in the FAX mode or enters the TAD mode in the TEL mode).

< WSW37 >

Selector No.	Function	Setting and Specifications
1	Printout of the stored image data of an unsent document onto an error report	0: No 1: Yes
2	Erasure of the stored image data of an unsent document at the time of the subsequent in-memory message transmission	0: No 1: Yes
3 8	Not used.	

- Selector 1: Printout of the stored image data of an unsent document onto an error report

This selector determines whether or not to print out the 1st-page image data of a document onto the error report if the document image data stored in the temporary memory cannot be transmitted normally.

- Selector 2: Erasure of the stored image data of an unsent document at the time of the subsequent in-memory message transmission

If in-memory message transmission fails repeatedly when selector 1 is set to "1," the temporary memory will be occupied with image data. Setting selector 2 to "1" will automatically erase the stored 1st-page image data of an unsent document at the time of the subsequent in-memory message transmission only when recording paper or toner runs out.

< WSW38 >

Selector No.	Function	Setting and Specifications
1 2	Setting of the equalizer	No. 1 2 0 0: Automatic 0 1: Automatic 1 0: Fixed to 4 points 1 1: Fixed to 16 points
3	Sending level of guard tone at phase 2	0: Normal - 7 db 1: Normal
4	Stepping down the transmission speed at fallback each	0: 2,400 bps 1: 4,800 bps
5 6	Automatic control of modem's EQM gain for proper transmission speed choice	No. 5 6 0 0: For higher transmission speed than the current setting 0 1: No change from the current setting 1 0: For lower transmission speed than the current setting 1 1: For further lower transmission than the setting made by 1, 0
7	Redialing when a communications error occurs	0: ON 1: OFF
8	Detection of CED for stopping CNG	0: ON 1: OFF

Note:

WSW38 takes effect only when the V.34 mode is permitted (WSW19, selector 7) in models supporting V.34 mode.

- Selectors 1 and 2: Setting of the equalizer

These selectors set the equalizer's training level to be applied if the machine fails to send training due to weak line connection. If these selectors are set to "0, X," the modem will automatically set the appropriate training level.

- Selector 3: Sending level of guard tone at phase 2

This selector sets the sending level of guard tone for 1800 Hz to be sent at Phase 2 in the V.34 mode.

- Selector 4: Stepping down the transmission speed at fallback each

This selector determines how much the modem steps down the transmission speed at fallback when called by the remote station. If this selector is set to "1," the modem may step down the transmission speed from 33600 bps to 28800 bps by one-time fallback.

- Selectors 5 and 6: Automatic control of modem's EQM gain for proper transmission speed choice

These selectors determine how the modem controls the EQM (Eye Quality Monitor) gain for proper choice of the transmission speed, which applies if the modem selects higher transmission speed than the possible speed so that it always repeats falling back.

- Selector 8: Detection of CED for stopping CNG

If this selector is set to "0," the detection time of CED specified by WSW43, selectors 4 and 5 will apply.

< WSW39 >

Selector No.	Function	Setting and Specifications
1 4	First transmission speed choice for fallback	No. 1 2 3 4 No. 5 6 7 8 0 0 0 0: 2,400 bps 0 0 0 1: 4,800 bps 0 0 1 0: 7,200 bps 0 0 1 1: 9,600 bps 0 1 0 0: 12,000 bps 0 1 0 1: 14,400 bps 0 1 1 0: 16,800 bps 0 1 1 1: 19,200 bps 1 0 0 0: 21,600 bps 1 0 0 1: 24,000 bps 1 0 1 0: 26,400 bps 1 0 1 1: 28,800 bps 1 1 0 0: 31,200 bps 1 1 0 1: 33,600 bps 1 1 1 0: 33,600 bps 1 1 1 1: 33,600 bps
5 8	Last transmission speed choice for fallback	

Note:

WSW39 takes effect only when the V.34 mode is permitted (WSW19, selector 7) in models supporting V.34 mode. For the transmission speed setting in other modes, refer to WSW19.

- Selectors 1 through 8: First and last choices of transmission speed for fallback

These selectors are used to set the modem speed range. With the first transmission speed choice specified by selectors 1 through 4, the machine attempts to establish the transmission link via the modem. If the establishment fails, the machine automatically steps down to the next highest speed and attempts to establish the transmission link again. The machine repeats this sequence while stepping down the transmission speed to the last choice specified by selectors 5 through 8.

If the modem always falls back to a low transmission speed (e.g., 24,000 bps), set the first transmission speed choice to the lower one (e.g., modify it from 31,200 bps to 26,400 bps) in order to deactivate the high-speed modem function and reduce the training time for shorter transmission time.

WSW39 will be limited by selectors 3 through 8 on WSW40.

< WSW40 >

Selector No.	Function	Setting and Specifications			
1 2	Not used.				
3 8	Masking of symbol rate(s)	Not masking	Masking		
		No. 3	0	1	3429 symbols/sec
		No. 4	0	1	3200 symbols/sec
		No. 5	0	1	3000 symbols/sec
		No. 6	0	1	2800 symbols/sec
		No. 7	-	-	Not used.
		No. 8	0	1	2400 symbols/sec

Note:

WSW40 takes effect only when the V.34 mode is permitted (WSW19, selector 7) in models supporting V.34 mode.

- Selectors 3 through 8: Masking of symbol rate(s)

These selectors allow you to limit the transmission speed range in V.34 mode by masking the desired symbol rate(s). Transmission speeds assigned to the symbol rates are listed on the next page. The setting made by these selectors will limit the setting made by selectors 1 through 4 on WSW39.

If selector 3 is set to "1" to mask the 3429 symbols/second when the first transmission speed choice is 33600 bps (specified by selectors 1 through 4 of WSW39), for example, then the allowable maximum transmission speed will be limited to 31200 bps. If selector 8 is set to "1" to mask the 2400 symbols/second when the first transmission speed choice is 33600 bps, then the allowable maximum transmission speed remains 33600 bps.

If selector 8 is set to "1" to mask the 2400 symbols/second when the first transmission speed choice is 21600 bps (specified by selectors 1 through 4 on WSW39), then the allowable maximum transmission speed remains 21600 bps but the minimum transmission speed will be limited to 4800 bps.

Symbol rate	Transmission speed (bps)	Symbol rate	Transmission speed (bps)	Symbol rate	Transmission speed (bps)
2400	2,400	3000	4,800	3429	4,800
	4,800		7,200		7,200
	7,200		9,600		9,600
	9,600		12,000		12,000
	12,000		14,400		14,400
	14,400		16,800		16,800
	16,800		19,200		19,200
	19,200		21,600		21,600
	21,600		24,000		24,000
	2800		4,800		3000
7,200		28,800	31,200		
9,600		3200	4,800	33,600	
12,000			7,200		
14,400			9,600		
16,800			12,000		
19,200			14,400		
21,600			16,800		
24,000			19,200		
24,600			21,600		
			24,000		
			26,400		
			28,800		
		31,200			

< WSW41 >

Selector No.	Function	Setting and Specifications
1 3	ON-duration of the scanning light source at room temperature (Not used.)	No. 1 2 3 0 0 0: 16 hours 0 0 1: 24 hours 0 1 0: 12 hours 0 1 1: 8 hours 1 0 0: 4 hours 1 0 1: 2 hours 1 1 0: 10 min. 1 1 1: 0 min.
4	I-FAX relay report	0: ON 1: OFF
5 8	Modem attenuator	No. 5 6 7 8 0 0 0 0: -10 dBm 0 0 0 1: -11 dBm 0 0 1 0: -12 dBm 0 0 1 1: -13 dBm 0 1 0 0: -14 dBm 1 1 1 1: -25 dBm

- Selectors 1 through 3: ON-duration of the scanning light source at room temperature (Not used.)

If the scanning operation is started when the scanning light source is off, then it will come on for scanning. These selectors determine how long the light source is ON after scanning.

If these selectors are set to "1, 1, 1," the light source goes off immediately after the scanning sequence.

- Selectors 5 through 8: Modem attenuator

These selectors are used to adjust the transmitting level of the modem when the reception level at the remote station is improper due to line loss. This function applies to super G3 protocol signals.

< WSW42 >

Selector No.	Function	Setting and Specifications
1	Access to the incoming mail (POP3) server (Periodical or on-demand) (Not used.)	0: OFF 1: ON
2	Access to the outgoing mail (SMTP) server	0: OFF 1: ON
3	I-FAX relay (Not used.)	0: OFF 1: ON
4	JBIG encoding system	0: Not allowed 1: Allowed
5	Discharge detection	0: ON 1: OFF
6 8	Not used.	

< WSW43 >

Selector No.	Function	Setting and Specifications
1	Not used.	
2 3	Wait time for PC-Fax reception (Class 2) and FPTS command transmission	No. 2 3 0 0: 50 ms 0 1: 100 ms 1 0: 150 ms 1 1: 0 ms
4 5	Detection time of 2100 Hz CED or ANSam	No. 4 5 0 0: 200 ms 0 1: 300 ms 1 0: 400 ms 1 1: 500 ms
6	Not used.	
7	Automatic start of remote maintenance (Not used.)	0: No 1: Yes
8	JPEG coding	0: Disable 1: Enable

- Selector 8: JPEG coding

Setting this selector to "0" disables the machine from sending/receiving JPEG color images and from receiving JPEG monochrome images.

< WSW44 >

Selector No.	Function	Setting and Specifications
1 5	Copying speed control	No. 1 2 3 4 5 0 0 0 0 0: Max. 0 0 0 0 1: 1cpm 1 1 1 1 1: 31cpm
6 8	Effective time length of the white level compensation data obtained beforehand	No. 6 7 8 0 0 0: Obtained compensation data ineffective 0 0 1: 1 min. 0 1 0: 3 min. 0 1 1: 5 min. 1 0 0: 10 min. 1 0 1: 15 min. 1 1 0: 20 min. 1 1 1: 30 min.

Note:

Selectors 6 through 8 are applicable to flat head-type models only.

- Selectors 6 through 8: Effective time length of the white level compensation data obtained beforehand

These selectors determine how long compensation data obtained beforehand will keep effective.

< WSW45 >

Selector No.	Function	Setting and Specifications
1 3	Delay time from when documents are set until the ADF starts drawing them in	No. 1 2 3 0 0 0: No automatic drawing-in 0 0 1: 1 sec. 0 1 0: 2 sec. 0 1 1: 3 sec. 1 0 0: 4 sec. 1 0 1: 5 sec. 1 1 0: 6 sec. 1 1 1: 7 sec.
4 6	Periodical correction intervals of the reference voltage to be applied to white level compensation for document scanning, during standby	No. 4 5 6 0 0 0: No correction of reference voltage during standby 0 0 1: 10 sec. 0 1 0: 30 sec. 0 1 1: 1 min. 1 0 0: 3 min. 1 0 1: 5 min. 1 1 0: 10 min. 1 1 1: 30 min.
7	Standby position of the CIS unit	0: CIS home position 1: Location of the white-level reference film
8	Line polarity reverse detection function	0: No 1: Yes

Note:

WSW45 is applicable only to flat head-type models.

- Selectors 1 through 3: Delay time from when documents are set until the ADF starts drawing them in

These selectors determine how long the ADF will delay automatic drawing-in of documents (to the scanning standby position) after you set them in the ADF, as well as determining whether or not the ADF automatically draws in documents.

- Selectors 4 through 6: Periodical correction intervals of the reference voltage applied to white level compensation for document scanning, during standby

These selectors set the correction intervals (in seconds) of the reference voltage to be applied to white level compensation for document scanning during standby, as well as determining whether or not the controller makes the reference voltage correction during standby. (Conventionally, the correction has been made immediately before the start of actual scanning)

This function takes effect in copying. Making the correction during standby may shorten the preparation time for copying.

Note:

Do not access these selectors.

- Selector 7: Standby position of the CIS unit

This selector determines whether the standby position of the CIS unit should be the home position or the location of the white-level reference film (attached to the inside of the scanner top cover). If the location of the reference film is selected, the CIS unit will not return to the home position so as to shorten the travel time, decreasing the preparation time for copying.

- Selector 8: Line polarity reverse detection function

Line polarity will be reversed if the phone is hung up at the other end of the line. If this selector is set to "1," the machine will detect the reverse polarity during an answering machine operation and thereby determine that the phone has been hung up.

< WSW46 >

Selector No.	Function	Setting and Specifications
1 2	Monitoring the PC ON/OFF state (Not used.)	No. 1 2 0 0: Disable 0 1: Monitor SELECT IN 1 0: Monitor STROBE 1 1: Monitor both SELECT IN and STROBE
3	Parallel port output pins kept at high level (Not used.)	0: Enable 1: Disable
4	Previous filtering parameters for white level compensation	0: Enable 1: Disable
5 8	Not used.	

Note:

Selector 4 is not applicable to models equipped with flat-bed scanners.

- Selectors 1 and 2: Monitoring the PC ON/OFF state (Not used.)

For the related functions, refer to WSW36, selectors 2 and 3.

- Selector 3: Previous filtering parameters for white level compensation (Not used.)

Setting this selector to "0" will keep all parallel output pins of the machine at high level. Use this setting if Resource Manager (bundled with MFC models) installed to WindowsNT running on the connected PC fails to monitor the power ON/OFF state of the machine.

- Selector 4: Previous filtering parameters for white level compensation

At the start of scanning operation, the machine usually initializes white and black level data stored in the EEPROM by scanning the white-level reference film attached to the inside of the scanner top cover. After long use of the machine, however, the film may be contaminated with dust or dirt.

Accordingly, incorrect white level data will be set up so that white vertical streaks will be brought on the scanning result.

Setting this selector to "0" (Enabled) will apply previously saved white level data instead of new incorrect compensation.

< WSW47 >

Selector No.	Function	Setting and Specifications
1	Handling paper at the occurrence of a paper feed timing error (Not used.)	0: Eject paper w/o print 1: Print on the current paper
2	Not used.	
3 4	Delay of FAX line disconnection when switching to the pseudo-ringing external telephone	No. 3 4 0 0: 200 ms 0 1: 400 ms 1 0: 700 ms 1 1: 1000 ms
5	Disable the ringer of external telephone at non-ring reception	0: No 1: Yes
6	Not used.	
7	Disable the ringer of external telephone with CAR signal when caller ID service is available	0: No 1: Yes
8	Switching between high-speed USB and full-speed USB	0: Auto switching between high-speed USB (ver. 2.0) and full-speed USB (ver. 1.1) 1: Fixed to full-speed USB (ver. 1.1)

Note:

- Selector 1 is applicable only to models equipped with flat-bed scanners.
- Selectors 3 and 4 are applicable only to models supporting pseudo-ringing of a connected external telephone.

- Selector 1: Handling paper at the occurrence of a paper feed timing error

When feeding paper to the print start position, the machine might cause a feed timing error so that the registration sensor goes ON signaling the presence of paper. This selector determines whether the machine prints on the current paper or ejects the current paper without printing and prints on the next paper.

- Selectors 3 and 4: Delay of FAX line disconnection when switching to the pseudo-ringing external telephone

When the machine receives a phone call, it can make the connected external telephone ring (so called pseudo-ringing). During pseudo-ringing, if you pick up the handset of the external telephone, the line might be disconnected due to cut-off of the line current. To hold the line, the machine may supply line current by making use of the pulse generator circuit that forms a parallel loop. This way the FAX line disconnection may be delayed. These selectors determine the delay period.

< WSW48 >

Selector No.	Function	Setting and Specifications
1 2	Not used.	
3 5	Number of network TWAIN PCs registered for each application	No. 3 4 5 0 0 0: 25 PCs 0 0 1: 50 PCs 0 1 0: 75 PCs 0 1 1: 100 PCs 1 0 0: 125 PCs 1 0 1: 150 PCs 1 1 0: 175 PCs 1 1 1: 200 PCs
6 8	USB setup latency (Not used.)	No. 6 7 8 0 0 0: Default period (default period without change) 0 0 1: Shorten 1 0 1 0: Lengthen 1 0 1 1: Lengthen 2 1 0 0: Lengthen 3 1 0 1: Lengthen 4 1 1 0: Shorten 2 1 1 1: Shorten 3

- Selectors 6 through 8: USB setup latency (Not used.)

These selectors should not be disturbed.

< WSW49 >

Selector No.	Function	Setting and Specifications
1 2	RAM disc size in PCL/ PS	No. 1 2 0 0: None 0 1: 1MB 1 0: 2MB 1 1: 4MB
3	End-of-copying beep	0: Yes 1: No
4 5	Command flag detection time	No. 4 5 0 0: 150 ms 0 1: 350 ms 1 0: 550 ms 1 1: 750 ms
6 7	CIS unit warm-up time adjustment (Not used.)	No. 6 7 0 0: Not adjusted 0 1: 80 % 1 0: 120 % 1 1: 150 %
8	Print in black (Not used.)	0: No (Default) 1: Yes

- Selectors 4 and 5: Command flag detection time

After receiving a command flag, the machine will wait for the command that should follow for the time length specified by these selectors.

- Selectors 8: Print in black (Not used.)

If any of the color inks have been deleted ("out of ink"), no printing can occur by default. If this selector is set to "1," in cases of "out of ink" data will be printed only in black ink. However, in such circumstances, no color data will be printed.

< WSW50 >

Selector No.	Function	Setting and Specifications
1 2	Percentage voltage for interpreting the external telephone as being hooked up (based on the network's standard voltage)	No. 1 2 0 0: 50 % 0 1: 80 % 1 0: 30 % 1 1: No detection
3	DC mask curve table to be applied when the line is connected	0: Apply the initial value specified by local regulations 1: Apply table DC5 prepared specially
4	AC impedance to be applied when the line is connected	0: 600Ω termination 1: ZR termination
5 6	Current control to be applied immediately after connection of the line	No. 5 6 0 0: Standard 0 1: Increase start-up current for termination 1 0: Fine current control for termination 1 1: Not used. (equal to "0, 0")
7 8	AC voltage threshold for detection of ring	No. 7 8 0 0: 19 V 0 1: 11 V 1 0: 25 V 1 1: 31 V

Note:

WSW50 is applicable to models equipped with SDAA circuits.

- Selectors 5 and 6: Current control to be applied immediately after connection of the line

FAX models equipped with an SDAA circuit (on which an NTU chip is mounted) might not be connected to a broad band line such as an ADSL (Asynchronous Digital Subscriber Line) in a stable condition. If those models fail to connect to such a line, try to change the current control to be applied immediately after connection of the line by using selectors 5 and 6.

If selectors 5 and 6 are set to "0" and "1," respectively, the SDAA draws more current, decreasing the period required to terminate the current control. If they are set to "1" and "0," the SDAA finely controls precision of the termination current against the voltage to approach nearer to the specified DC curve that specifies the current vs. voltage characteristics of the network termination. Selecting either control may solve an unstable connection problem.

< WSW51 >

Selector No.	Function	Setting and Specifications
1	Output of communications error report when transmission verification report is disabled	0: Enable 1: Disable
2	CR motor torque variation reduction control (Not used.)	0: Yes 1: No
3 4	Cordless handset microphone volume	No. 3 4 0 0: Middle (Default) 0 1: Low 1 0: High 1 1: Very high
5 7	Main unit microphone level and echo cancellation ON/OFF function (Not used.)	No. 5 6 7 0 0 0: Microphone level 0 with echo cancellation OFF 0 0 1: Microphone level 1 with echo cancellation ON 0 1 0: Microphone level 2 with echo cancellation ON 0 1 1: Microphone level 3 with echo cancellation ON
8	Support between nearly empty → empty when main unit cover opened after nearly empty detected (Not used.)	0: Empty state detected when main unit cover opened 1: Nearly empty state maintained when main unit cover opened

Note:

Selectors 3 and 4 are applicable only to models equipped with cordless handsets.

- Selector 2: CR motor torque variation reduction control (Not used.)

Printing quality may be lowered due to changes in the head/carriage travel speed resulting from variations in the torque of the CR motor during operation. If selector 2 is set to "0," the CR motor drive current will be controlled so as to inhibit variations in torque, resulting in a smooth CR motor rotation.

- Selectors 5 through 7: Microphone level and echo cancellation ON/OFF (Not used.)

Microphone level 0 is the highest microphone volume setting. The higher the microphone level, the lower the microphone volume setting. The microphone level can also be adjusted by means of a user function. In other words, the microphone level depends on the setting of the user function as well as on the setting by these selectors.

Using the echo cancellation function, it is possible to reduce echoes both during speaking and hearing.

- Selector 8: Support between nearly empty → empty with main unit cover open after nearly empty detection (Not used.)

If this selector is set to "0," the nearly empty ink state, if detected, will be replaced by the empty ink state when the main unit cover is opened, thus prompting the user to replace the ink cartridge immediately.

< WSW52 >

Selector No.	Function	Setting and Specifications
1 3	Cordless handset microphone level and echo cancellation ON/OFF	No. 1 2 3 0 0 0: Microphone level 0 with echo cancellation OFF 0 0 1: Microphone level 1 with echo cancellation ON 0 1 0: Microphone level 2 with echo cancellation ON 0 1 1: Microphone level 3 with echo cancellation ON
4 6	External telephone pseudo ringing signal frequency setting	No. 4 5 6 0 0 0: 16 Hz 0 0 1: 20 Hz 0 1 0: 24 Hz 0 1 1: 28 Hz 1 0 0: 32 Hz 1 0 1: 16 Hz 1 1 0: 16 Hz 1 1 1: 16 Hz
7	Caller ID (number display) display after the machine has returned to TEL mode from FAX mode (Not used.)	0: Yes 1: No
8	Dial display during transmission (Not used.)	0: Yes 1: No

- Selectors 4 through 6: External telephone pseudo ringing signal frequency setting

External telephone ringing sound can be changed.

- Selector 7: Caller ID (number display) display continued after the machine has returned to TEL mode from FAX mode (Not used.)

If this function is selected, the caller ID number (number display) will continue to be displayed even after the TEL → FAX → TEL mode changes.

- Selector 8: Dial display during transmission (Not used)

If this selector is set to "0," the dial number of the fax transmission destination will be displayed until such time as the fax transmission has been completed.

< WSW53 >

Selector No.	Function	Setting and Specifications
1 2	Not used.	
3 4	Caller ID (number display) FSK receiving timing delay setting	No. 3 4 0 0: 0 ms 0 1: 100 ms 1 0: 150 ms 1 1: 200 ms
5 6	Caller ID (number display) instantaneous interrupt detection time setting	No. 5 6 0 0: 20 ms 0 1: 10 ms 1 0: 30 ms 1 1: 0 ms
7	CNG detection retry after invalid CNG detected	0: Yes 1: No
8	Decompression of JPEG compressed file (Not used.)	0: ASIC (Default) 1: Software

Note:

Selector 8 is applicable only to models equipped with photo media capture.

- Selectors 3 through 6: Caller ID (number display) FSK receiving timing delay setting and instantaneous interrupt detection time setting

If a call error occurs during use of caller ID (number display), it may be possible for the error to be corrected by adjustment these selectors. If the error cannot be thus corrected, try adjusting selectors 5 and 6.

- Selector 8: Decompression of JPEG compressed file (Not used.)

Decompress JPEG compressed files stored on the inserted memory card. (ASIC: application specified integrated circuit)., JPEG compressed files can be decompressed with an ASIC. If an image fails to be replayed correctly due to a decompression error, set this selector to "1" and use other proven decompression software instead.

< WSW54 >

Selector No.	Function	Setting and Specifications
1 2	PictBridge command delay time	No. 1 2 0 0: 100 ms (default) 0 1: 0 ms 1 0: 50 ms 1 1: 200 ms
3	More CNG detection cycles in user-friendly reception	0: No 1: 2 more cycles
4	Cordless handset ID recovery future	0: Valid 1: Invalid
5 6	Caller ID tone alert detection time length (Not used.)	No. 5 6 0 0: 10 ms (default) 0 1: 20 ms 1 0: 30 ms 1 1: 40 ms
7	Caller ID mild pulse transmission (Not used.)	0: Yes 1: No (default)
8	Switching between DTMF and FSK for caller ID reception (Not used.)	0: DTMF 1: FSK (default)

Note:

- Selectors 1 and 2 are applicable only to models equipped with PictBridge.
 - Selector 4 is applicable only to models equipped with cordless handset(s).
 - Selectors 5 through 7 are applicable only to models designed for the UK market.
 - Selector 8 is applicable only to models designed for the Chinese market.
- Selector 1 and 2: PictBridge command delay time**
 These selectors specify the PictBridge command delay time that applies when the machine responds to the digital camera connected via PictBridge during negotiation. If the machine fails to receive data from the digital camera, change the delay time.
- Selector 3: More CNG detection cycles in user-friendly reception**
 If CNG detection fails even after adjustment of selectors 4 and 5 on WSW26, try adding 2 more cycles to the permitted number of CNG detection cycles.
- Selector 4: Cordless handset ID recovery**
 When this function becomes operative, if the cordless handset ID number registered on the main board does not match that registered on the cordless board, the cordless handset ID number registered on the main board will be automatically written onto the cordless board.
- Selectors 5 and 6: Caller ID tone alert detection time length (Not used)**
 In the event of a false detection of a caller ID tone alert, adjust the detection time length.
- Selector 7: Caller ID mild pulse transmission (Not used.)**
 If a caller ID (number display) cannot be displayed due to mild pulses transmitted after detection of tone alert, use this selector so as to make it impossible to transmit mild pulses.

- Selector 8: Switching between DTMF and FSK for caller ID reception (Not used)

If a caller ID (number display) cannot be received, switch from DTMF to FSK. This operation can also be performed by means of the menu, by switching between DTMF and FSK.

< WSW55 >

Selector No.	Function	Setting and Specifications
1 8	Interval of time required for the developing bias voltage correction (hour)	<p>0: The developing bias voltage correction is performed on each print job.</p> <p>1-72: The developing bias voltage correction is performed when a print job occurs at specified time or later.</p> <p>73-254: Not allowed to set.</p> <p>255 (0xFF): The developing bias voltage correction is not performed.</p>

The setting example of the selector number is as follows;

No.1 2 3 4 5 6 7 8

0 0 0 0 0 0 0 0 : The developing bias voltage correction is performed on each print job.

0 0 0 1 1 0 0 0 : The developing bias voltage correction is performed when a print job occurs after 24 hours (default value) or later.

0 0 0 1 0 0 1 0 : The developing bias voltage correction is performed when a print job occurs after 72 hours or later.

1 1 1 1 1 1 1 1 : The developing bias voltage correction is not performed.

- Selector 1 to 8: Interval of time required for the developing bias voltage correction

To keep the density of four colors evenly, the developing bias voltage correction is performed when a print job occurs at specified time or later.

< WSW56 >

Selector No.	Function	Setting and Specifications
1	PS emulation function setting (Not used.)	0: Invalid 1: Valid
2	Not used.	
3	“Last Job Reprint” function setting	0: Invalid 1: Valid
4 8	Not used.	

- Selector 3: “Last Job Reprint” function setting

Setting this selector to “0” makes the machine not to reprint the “Last Job Print” data such as confidential document in order to prevent the misuse.

< WSW57 >

Selector No.	Function	Setting and Specifications
1 3	Caller ID judgment voltage (to be distinguished from rings) (Not used.)	No. 1 2 3 0 0 0: 0 V 0 0 1: 5 V (Default) 0 1 0: 10 V 0 1 1: 15 V 1 0 0: 20 V 1 0 1: 25 V 1 1 0: 30 V 1 1 1: Max.
4 6	Caller ID judgment voltage (to be distinguished from reverse polarity voltages) (Not used.)	No. 4 5 6 0 0 0: 0 V 0 0 1: 5 V (Default) 0 1 0: 10 V 0 1 1: 15 V 1 0 0: 20 V 1 0 1: 25 V 1 1 0: 30 V 1 1 1: Max.
7	Not used.	
8	Base unit start button after cordless handset dialing	0: Invalid (Default) 1: Valid

Note:

Selectors 1 through 6 are applicable only to models designed for the European market.

- Selectors 1 through 3: Caller ID judgment voltage (to be distinguished from rings) (Not used.)

If caller IDs cannot be displayed because of confusion with rings due to variations in the voltage, increase the judgment voltage.

However, do make sure that the voltage value set by selectors 1 through 3 of this switch is equal to, or greater than, the value set by selectors 4 through 6 of the same switch.

- Selectors 4 through 6: Caller ID judgment voltage (to be distinguished from reverse polarity voltages) (Not used.)

If caller IDs cannot be displayed because reverse polarities cannot be detected due to a large difference between line voltages in a reverse polarity condition and in a steady condition, increase the judgment voltage.

However, do make sure that the voltage value set by selectors 1 through 3 of this switch is equal to, or greater than, the value set by selectors 4 through 6 of the same switch.

- Selector 8: Base unit start button after cordless handset dialing

Even if the base unit start button is pressed to start a FAX transmission during calling when this selector is in its default state, no FAX transmission will occur. By using this selector, it is possible to make the base unit start button operative after cordless handset dialing.

< WSW58 >

Selector No.	Function	Setting and Specifications
1 3	Prevention of line interrupt during ICM recording (ratio of guard tone response time to call end tone ON time) (Not used.)	No. 1 2 3 0 0 0: Invalid 0 0 1: 10 % 0 1 0: 20 % 0 1 1: 30 % (Default) 1 0 0: 40 % 1 0 1: 50 % 1 1 0: 60 % 1 1 1: 70 %
4 7	Not used.	
8	Improvement of DTMF detecting function	0: OFF 1: ON

Note:

Selectors 1 through 3 are applicable only to models equipped with built-in TADs.

- Selectors 1 through 3: Prevention of line interrupt during ICM recording (ratio of guard tone response time to call end tone ON time) (Not used.)

If an ICM tone is detected as a call end tone by error, this machine will release the line even during ICM recording. To avoid this problem, change the setting for the ratio of guard tone response time to the call end tone ON detection time.

If the actual percentage of guard tone response time is greater than the percentage set by selectors 1 through 3, this machine will judge that the call end tone has not yet been detected and will continue ICM recording.

< WSW59 >

Selector No.	Function	Setting and Specifications
1	USB serial number (SN) transmission enabled/disabled	0: USB serial number transmitted/ USB serial number not transmitted 1: Frame length selection
2 8	Not used.	

- Selector 1: Frame length selection

This is intended to prevent the problem of a continued increase in USB ports when serial numbers are transmitted from the MFC to a Windows Vista-based PC.

It is intended only to prevent a problem specific to Windows Vista; its default setting is "0: USB SN enabled."

< WSW60 >

Selector No.	Function	Setting and Specifications
1 8	Not used.	

< WSW61 >

Selector No.	Function	Setting and Specifications
1 4	Change rate of the CIS scanning light intensity to judge to be stable in the long time mode	No. 1 2 3 4 0 0 0 0: 1% (Default) 0 0 0 1: 0.5% 0 0 1 0: 3% 0 0 1 1: 5% 0 1 0 0: 10% 0 1 0 1: 15% 0 1 1 0: 20% 1 1 1 1: 100% * * (Scans immediately after the light source ON)
5 8	Change rate of the CIS scanning light intensity to judge to be stable in the short time mode	No. 5 6 7 8 0 0 0 0: 5% (Default) 0 0 0 1: 1% 0 0 1 0: 3% 0 0 1 1: 10% 0 1 0 0: 15% 0 1 0 1: 20% 0 1 1 0: 30% 1 1 1 1: 100% * * (Scans immediately after the light source ON)

- Selectors 1 through 8: Change rate of the CIS scanning light intensity to judge to be stable.

The light intensity of the CIS unit is changed widely immediately after the light source is on, that influences scanning density. Therefore, the first scanning after the light source is off and on is started after the change rate of the CIS light intensity is stabilized in the definite range. These selectors set the change rate to start the scanning operation above. If you want to start scanning immediately even if the image quality is not good, set the rate to high.

Long / short time mode:

The selectors are divided between the long and short time modes depending on the scanning resolution and black and white or color mode. The long time mode is selected in color scanning at 600dpi or more, or in black and white scanning at 1200dpi. The short time mode is selected in other scanning conditions than the above.

< WSW62 >

Selector No.	Function	Setting and Specifications					
1 4	Change rate of the CIS light intensity for scanning pages compensation	No. 1	2	3	4	Change rate for simple compensation	Change rate for regular compensation
		0	0	0	0	3%	10% *
		0	0	0	1	3%	7%
		0	0	1	0	3%	15%
		0	0	1	1	3%	20%
		0	1	0	0	3%	25%
		0	1	0	1	5%	10%
		0	1	1	0	5%	15%
		0	1	1	1	5%	20%
		1	0	0	0	5%	25%
		1	0	0	1	7%	15%
		1	0	1	0	7%	20%
		1	0	1	1	7%	25%
		1	1	0	0	10%	15%
1	1	0	1	10%	20%		
1	1	1	0	10%	25%		
1	1	1	1	15%	30%		
* Default							
5 6	Selection of judging function for simple scanning pages compensation	No. 5	6				
		0	0: Judges according to the change rate				
		0	1: Not judges				
		1	0: Judges every page				
7 8	Selection of judging function for regular scanning pages compensation	No. 7	8				
		0	0: Judges according to the change rate				
		0	1: Not judges				
		1	0: Judges every page				

- Selectors 1 through 4: Change rate of the CIS light intensity for scanning pages compensation

The light intensity of the CIS unit may be changed (decreased, especially), and difference of density may appear among the scanning pages if continuous copying or scanning is implemented from the ADF for a long time. To prevent the above, in simplex copying or scanning from the ADF, the machine checks the change rate of the light intensity in every page. Then, it takes the compensation data again if the rate is over the set value. These selectors set the change rate of the light intensity to control such operations.

Change rate for simple compensation:

Change rate when compensating the pages using the standard data in the machine memory without moving the CIS unit to the designated position for scanning of the compensation data.

Change rate for regular compensation:

Change rate when compensating the pages with moving the CIS unit to the designated position for scanning of the compensation data and obtaining the data actually.

For duplex scanning, this setting is not used since the machine takes the compensation data of every page again.

- Selectors 5 and 6 / 7 and 8: Selection of judging function for scanning pages compensation

These selectors set the condition to control scanning pages compensation. Some operation losses occur in the control of the compensation. If you want to start scanning immediately even if the image quality is not good, set to "01: Not discriminates". If you want to give priority to the image quality even though losses are increased, select one of others ("00: Discriminates depending on the rate of change" or "10: Discriminates every page").

APPENDIX 2 DELETION OF PERSONAL INFORMATION

The personal information in the machine is recorded in the EEPROM on the main PCB. It cannot be deleted all by a single operation. Use Function code 01 in the maintenance mode, unplug the AC cord from the electrical outlet, and disconnect the backup battery.

■ Operating Procedure

[1] Using Function code 01

Using Function code 01 (EEPROM Parameter Initialization) in the maintenance mode deletes the following data that have been recorded in the EEPROM on the main PCB:

- Activity report
- Station ID data
- Outside line number
- One-touch dialing
- Speed dialing
- Group dialing
- Call transfer data

<Operating Procedure>

- (1) Press the **Menu** and **Black Start** buttons in this order. Next press the **▲** button four times to make the machine enter the maintenance mode.

TIP:

FAX models equipped with a numerical keypad can enter the maintenance mode in the same way as conventional models; that is, by pressing the **Menu**, *****, **2**, **8**, **6** and **4** buttons in this order.

- (2) Press the **0** and **1** buttons in this order in the initial stage of the maintenance mode.
Parameter initialization starts and the "PARAMETER INIT" appears on the LCD.
- (3) Upon completion of parameter initialization, the machine beeps for one second and returns to the initial stage of the maintenance mode.

[2] Unplugging the AC cord from the electrical outlet and disconnecting the backup battery

Unplugging the AC cord from the electrical outlet and disconnecting the backup battery deletes the Caller ID list, fax data received into memory, transmission verification report (for image), broadcasting report and batch transmission data (in the memory).

<Operating Procedure>

- (1) Unplug the AC cord from the electrical outlet.
- (2) For models with backup battery, disconnect the backup battery harness from the main PCB.
- (3) Leave the machine for approx. 24 hours.

[3] Restoring the network settings

The procedure below allows you to return the LAN settings to the factory setting values.

<Operating Procedure>

- (1) Press the **Menu** button. Next press the ▲ or ▼ button to select "LAN". Press the **OK** button
- (2) Press the ▲ or ▼ button to select "Factory Reset". Press the **OK** button
- (3) Press the **1** button select "Reset".
- (4) Press the **1** button select "Yes".

APPENDIX 3 SERIAL NUMBERING SYSTEM

Each machine has a serial number label for the machine itself and property labels for some other parts. Refer to the information below for the meaning of the serial number and property codes and the location of each label.

Serial number labels for the machine itself

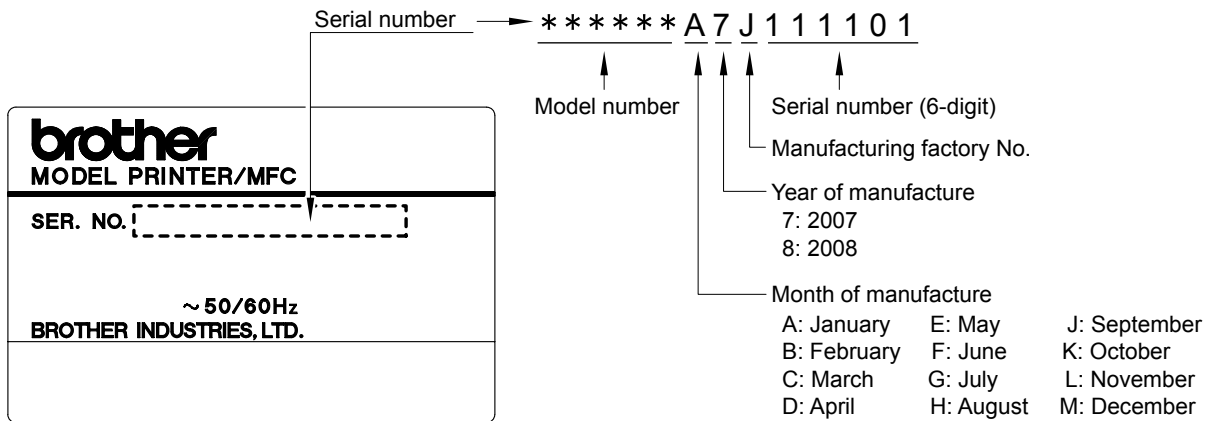

Fig. App3-1

<Location>

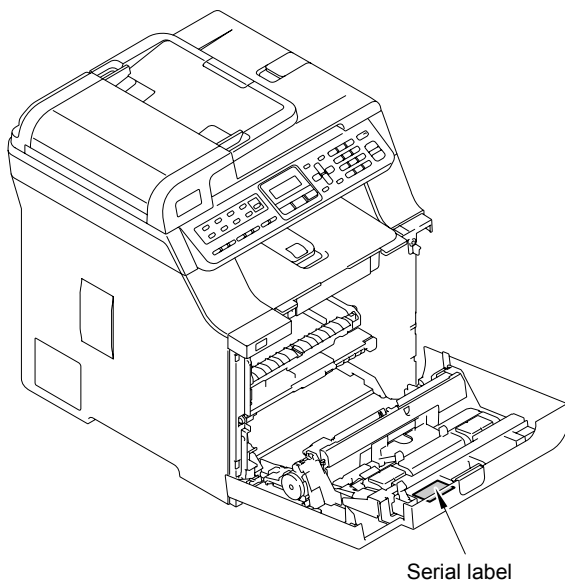

Fig. App3-2

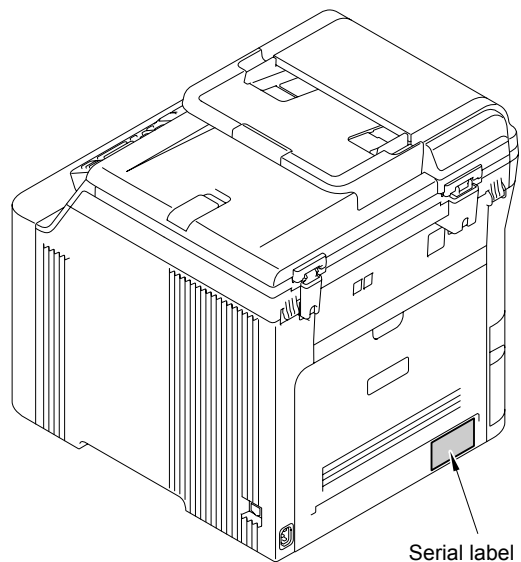

Fig. App3-3

■ Waste toner box serial label

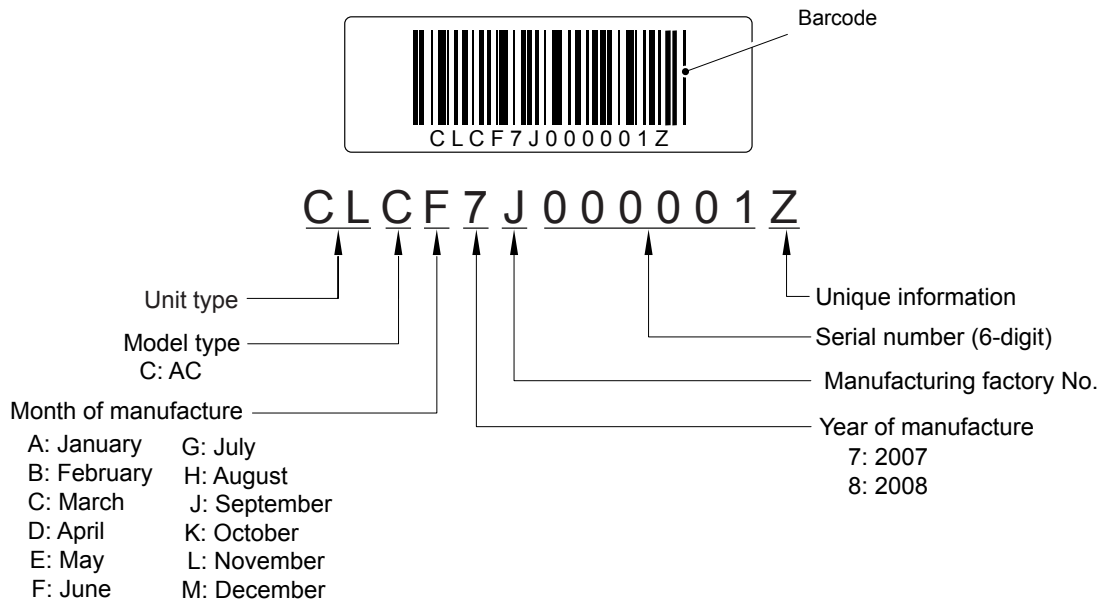

Fig. App3-4

<Location>

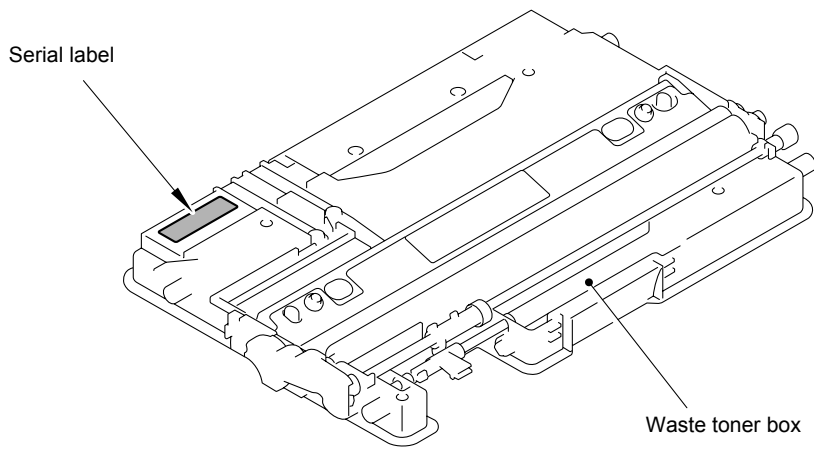

Fig. App3-5

■ Belt unit serial label

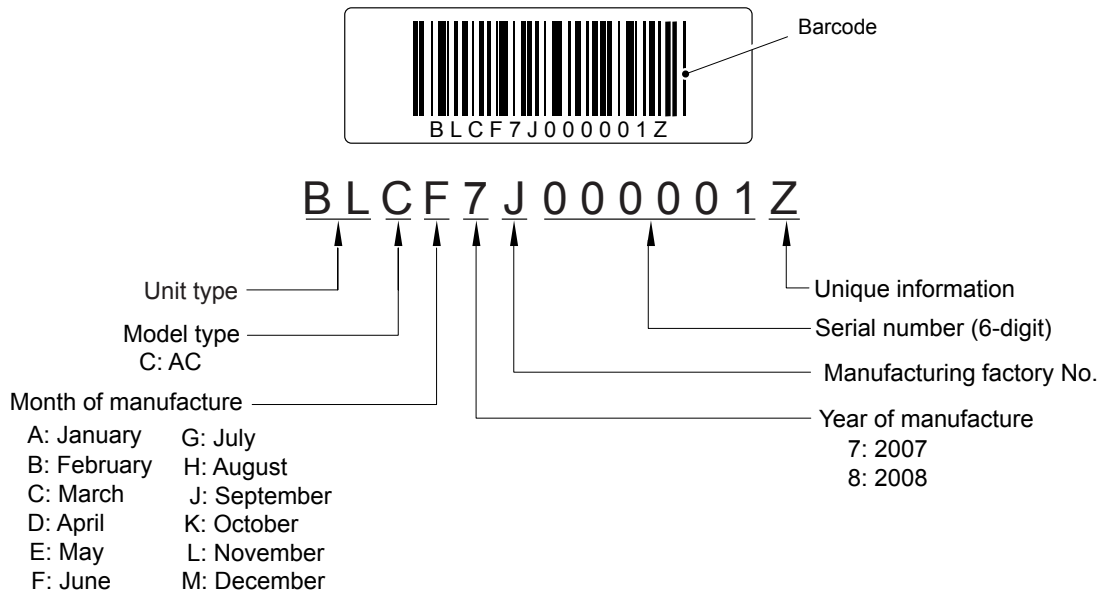

Fig. App3-6

<Location>

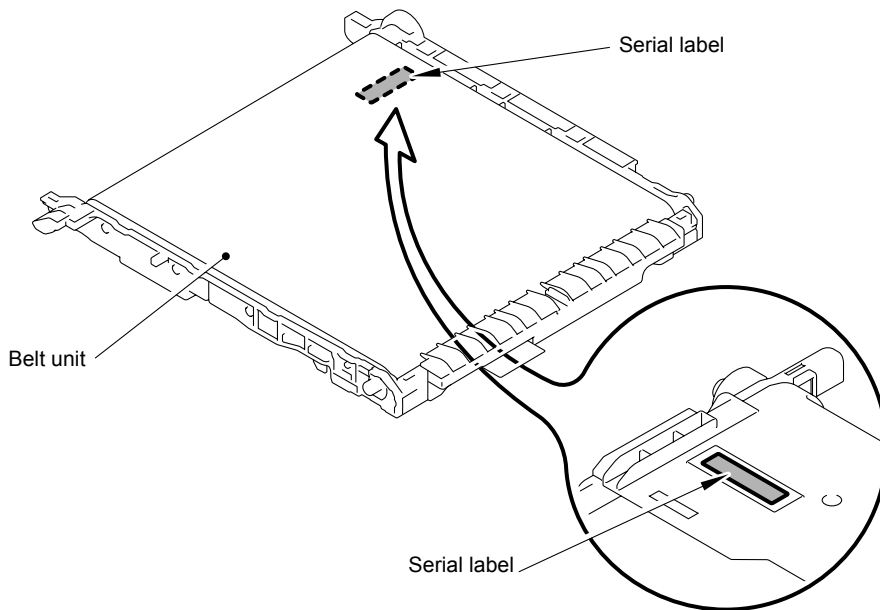

Fig. App3-7

■ Toner cartridge(K, Y, M, C) and Drum unit serial label

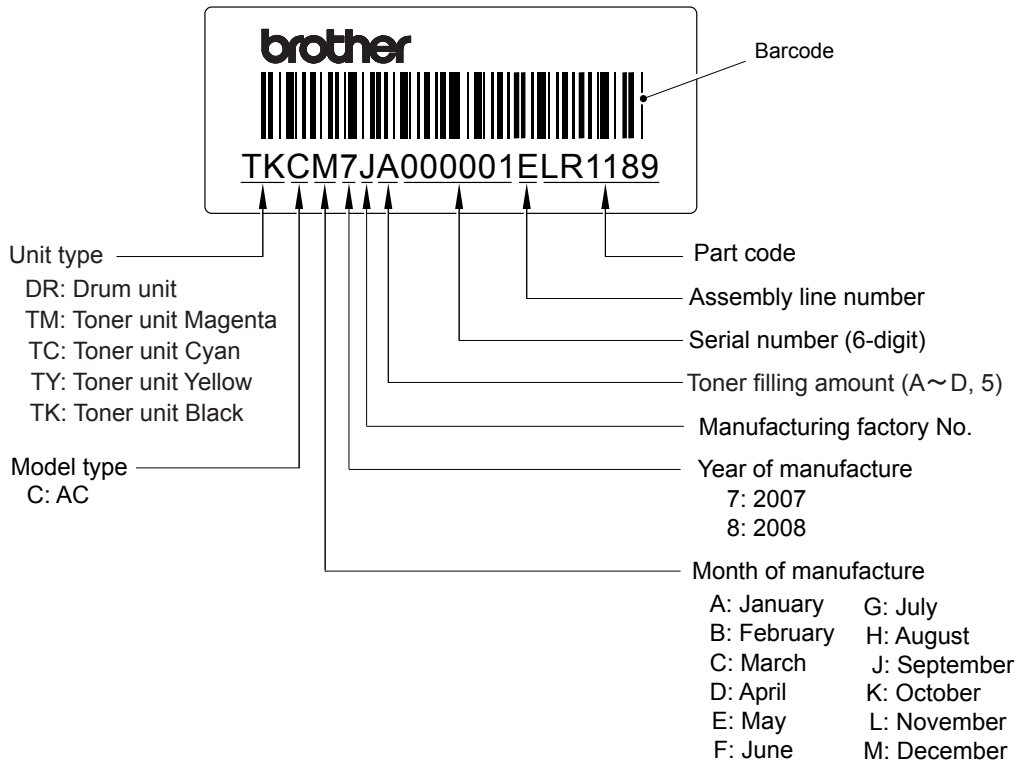

Fig. App3-8

<Location>

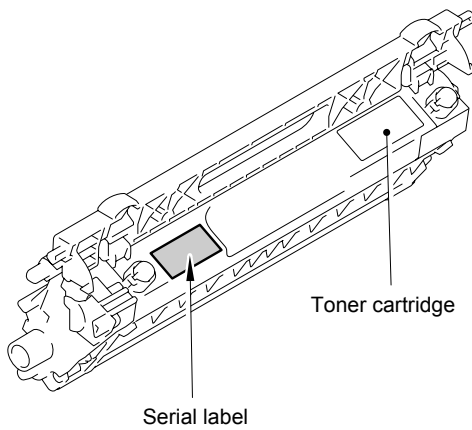

Fig. App3-9

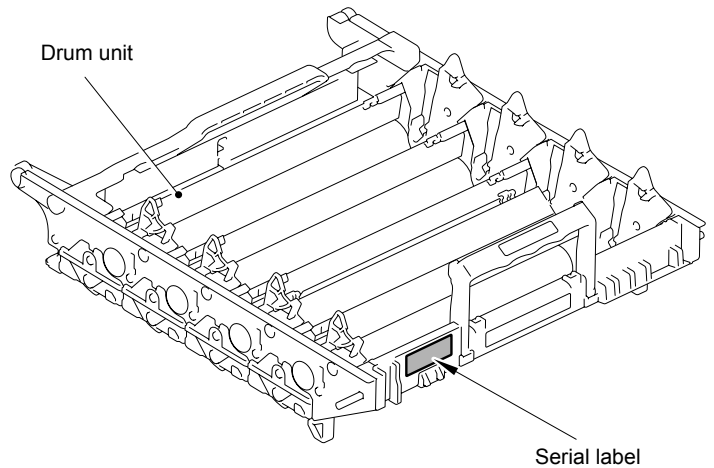

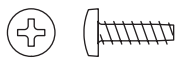
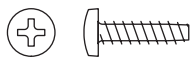





Fig. App3-10

APPENDIX 4 SCREW CATALOGUE





Taptime, bind B

Taptime, bind B M3x8	
Taptime, bind B M3x10	
Taptime, bind B M3x12	
Taptime, bind B M4x10	
Taptime, bind B M4x12	

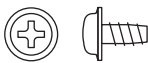

Taptime, bind S

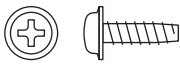
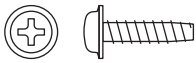
Taptime, bind S M3x6	
-------------------------	---

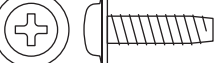

Taptime, cup B

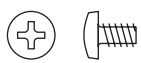
Taptime, cup B M3x6	
Taptime, cup B M3x8	
Taptime, cup B M3x10	
Taptime, cup B M3x12	
Taptime, cup B M4x10	
Taptime, cup B M4x12	
Taptime, cup B M4x14	

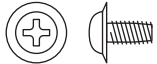

Screw, bind

Screw, bind M3x5	
Screw, bind M3x8	

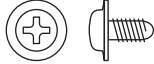
Taptime, cup S

Taptime, cup S M3x6	
Taptime, cup S M3x8	
Taptime, cup S M4x8	
Taptime, cup S M3x6 SR	

Shoulder screw

Shoulder screw	
Shoulder screw	

Screw, cup

Screw, cup M3x6	
--------------------	---

Taptime, pan

Taptime, pan B M4X14	
----------------------	---



Taptime, flat B

Taptime, flat B M3x10	
--------------------------	---

Screw flanged

Screw flanged M3x3.5	
-------------------------	---

Screw pan (S/P washer)

Screw pan (S/P washer) M3x6	
Screw pan (S/P washer) M3.5x6	
Screw pan (S/P washer) M4x8	

APPENDIX 5 HOW TO MAKE THE DRUM UNIT REMOVE SHEET

Make the drum unit remove sheet following the procedures below and use it when packing the drum unit.

< Requirements >

- A3 or ledger-size paper
- A4 or letter-size paper

< Procedures >

- (1) Cut the A3 or ledger-size paper and attach the double-faced adhesive tape referring to the figure below.

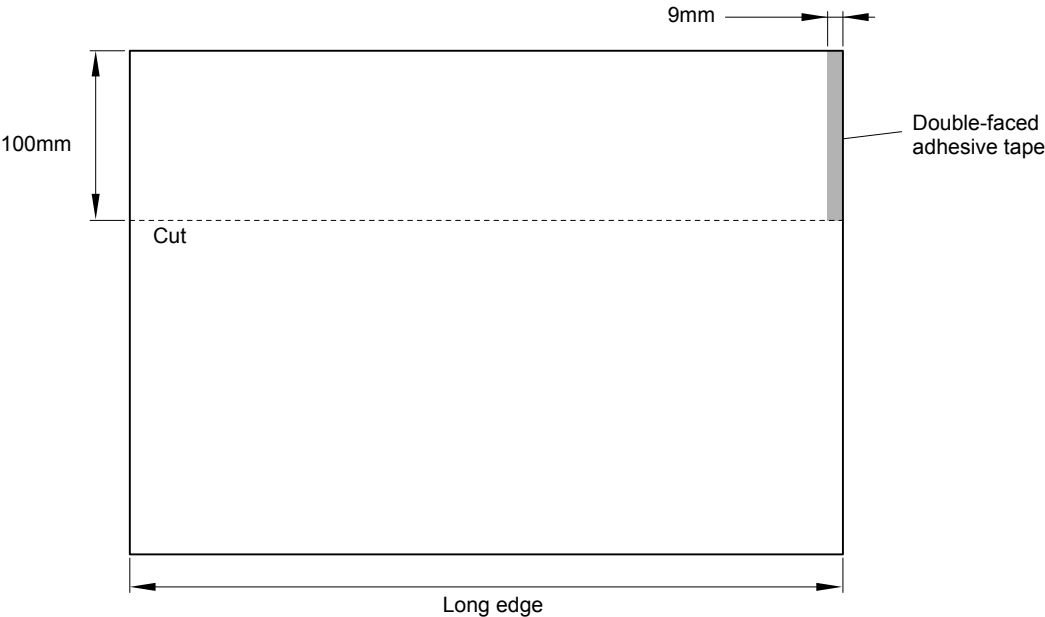

Fig. App5-1

- (2) Attach the double-faced adhesive tape onto the A4 or letter-size paper.

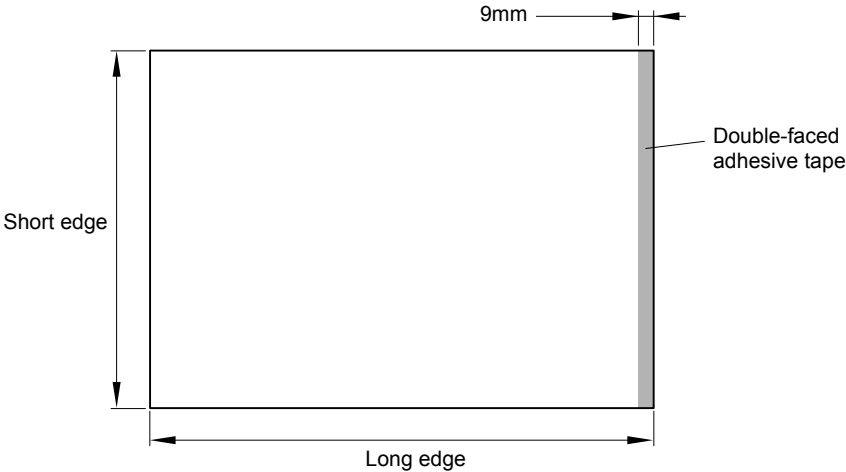

Fig. App5-2

- (3) Align those two sheets of paper with the marking lines on the drum unit remove sheet and attach them.

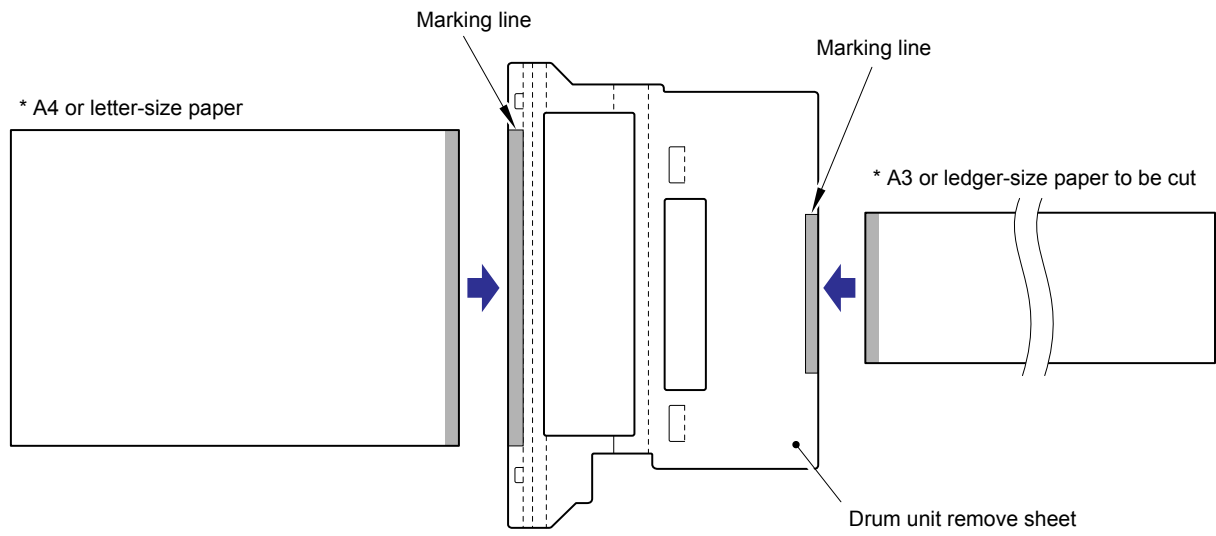

Fig. App5-3

APPENDIX 6 REFERENCES

This page provides reference information. It is possible to get the full instructions of the subjects listed by just clicking on the links below.

1. Error codes

(Refer to [“2.1 Error Indication”](#), Chapter 1 of the Service Manual.)

2. Error message

(Refer to [“2.2 Error Cause and Remedy”](#), Chapter 1 of the Service Manual.)

3. Diameter of rollers

(Refer to [“4.2 Diameter of Rollers”](#), Chapter 1 of the Service Manual.)

4. Periodical replacement parts

(Refer to [“2.1 Periodical Replacement Parts”](#), Chapter 2 of the Service Manual.)

5. Reset parts life

(Refer to [“2.3 Parts Life Reset Function”](#), Chapter 2 of the Service Manual.)

6. Machine specification

(Refer to [“2. SPECIFICATIONS LIST”](#), Reference 1 of the Service Reference Manual.)

7. Paper specification

(Refer to [“2.6 Paper”](#), Reference 1 of the Service Reference Manual.)

8. Toner cartridge weight information

(Refer to [“APPENDIX 1 TONER CARTRIDGE WEIGHT INFORMATION”](#), of the Service Reference Manual.)