

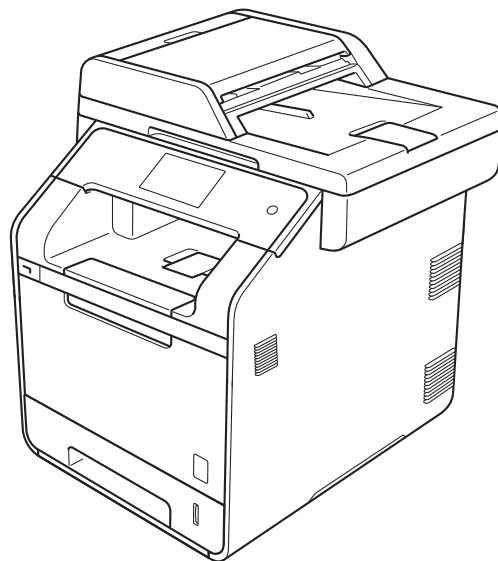

Brother Color Laser MFC SERVICE MANUAL

**MODEL: DCP-L8400CDN/L8450CDW
MFC-L8600CDW/L8650CDW
MFC-L8850CDW/L9550CDW**



Read this manual thoroughly before maintenance work.
Keep this manual in a convenient place for quick and easy reference at all times.

March 2014
SM-FAX157
8CE5*
(7)

TRADEMARKS

Brother is a trademark of Brother Industries, Ltd.

Microsoft, Windows, Windows NT, Windows Vista, Windows Server, Internet Explorer and Outlook are either registered trademarks or trademarks of Microsoft Corporation in the United States and/or other countries.

Apple, Macintosh, Mac OS, iPad, iPhone, iOS, iPod touch and OS X are trademarks of Apple Inc., registered in the United States and other countries.

Linux is the registered trademark of Linus Torvalds in the U.S. and other countries.

UNIX is a registered trademark of The Open Group in the United States and other countries.

Intel is trademark of Intel Corporation in the U.S. and/or other countries.

Adobe, Illustrator, PostScript, and PostScript 3 are either registered trademarks or trademarks of Adobe Systems Incorporated in the United States and/or other countries.

Wi-Fi, Wi-Fi Alliance and Wi-Fi Protected Access are registered trademarks of the Wi-Fi Alliance.

WPA, WPA2, Wi-Fi Protected Setup log and Wi-Fi Direct are trademarks of the Wi-Fi Alliance.

FLICKR is a registered trademark of Yahoo! Inc.

AOSS is a trademark of Buffalo Inc.

Android, Google Cloud Print, Google Drive, Google Play and Picasa Web Albums are trademarks of Google Inc. Use of this trademark is subject to Google Permissions.

Nuance, the Nuance logo, PaperPort and ScanSoft are trademarks or registered trademarks of Nuance Communications, Inc. or its affiliates in the United States and/or other countries.

Firefox is a registered trademark of the Mozilla Foundation.

EVERNOTE and the Evernote Elephant logo are trademarks of Evernote Corporation and used under a license.

Each company whose software title is mentioned in this manual has a Software License Agreement specific to its proprietary programs.

Any trade names and product names of companies appearing on Brother products, related documents and any other materials are all trademarks or registered trademarks of those respective companies.

OPEN SOURCE LICENSING REMARKS

This product includes open-source software.

Please visit the Brother Solutions Center at <http://solutions.brother.com/> to view the Open Source Licensing Remarks and Copyright information.

COPYRIGHT AND LICENSE

©2014 Brother Industries, Ltd. All rights reserved.

This product includes software developed by the following vendors:

©1983-1998 PACIFIC SOFTWARES, INC. ALL RIGHTS RESERVED.

©2008 Devicescape Software, Inc. All rights reserved.

This product includes the "KASAGO TCP/IP" software developed by ZUKEN ELMIC, Inc.

OTHER INFORMATION

FlashFX[®] is a registered trademark of Datalight, Inc.

FlashFX[®] Copyright 1998-2010 Datalight, Inc.

U.S. Patent Office 5,860,082/6,260,156

FlashFX[®] Pro[™] is a trademark of Datalight, Inc.

Reliance[™] is a trademark of Datalight, Inc.

Datalight[®] is a registered trademark of Datalight, Inc.

Copyright 1989-2010 Datalight, Inc., All Rights Reserved

CONTENTS

SAFETY INFORMATION I

CHAPTER 1 SUPPLEMENTAL SPECIFICATIONS

1.1 General.....	1-1
1.2 Network Connectivity.....	1-3
1.3 Service Information.....	1-4
1.4 Supplies.....	1-5
1.5 Paper.....	1-7
1.5.1 Media specifications for ADF.....	1-7
1.6 Telephone.....	1-7
1.7 FAX (Only for the models with FAX function).....	1-8
1.8 Copy.....	1-9
1.9 Scanner.....	1-10

CHAPTER 2 ERROR INDICATION AND TROUBLESHOOTING

1. INTRODUCTION2-1

1.1 Precautions.....	2-1
1.2 Checks before Commencing Troubleshooting.....	2-3

2. OVERVIEW.....2-5

2.1 Cross-section Drawing.....	2-5
2.1.1 Printer part.....	2-5
2.1.2 Scanning part.....	2-6
2.2 Paper Feeding.....	2-7
2.2.1 Printer part.....	2-7
2.2.2 Scanning part.....	2-8
2.3 Operation of Each Part.....	2-9
2.4 Block Diagram.....	2-11
2.5 Main Components.....	2-12

3. ERROR INDICATIONS.....2-13

3.1 Error Codes.....	2-13
3.2 Error Message.....	2-24

3.3 Communications Error Code	2-35
4. TROUBLESHOOTING	2-39
4.1 Error Cause and Remedy	2-39
4.2 Troubleshooting for Paper Feeding Problems	2-87
4.2.1 No paper feeding from paper tray 1	2-87
4.2.2 No paper feeding from T2 paper tray unit.....	2-88
4.2.3 No paper feeding from MP tray	2-89
4.2.4 Multiple sheets of paper are fed	2-90
4.2.5 Paper becomes wrinkled	2-90
4.2.6 Paper is fed at an angle.....	2-90
4.2.7 Paper curls	2-91
4.2.8 Unable to perform 2-sided printing	2-91
4.2.9 Paper jam	2-92
4.3 Troubleshooting for Image Defects.....	2-96
4.3.1 Image defect examples	2-96
4.3.2 Troubleshooting image defect	2-97
4.4 Troubleshooting for Software Problems	2-114
4.4.1 Unable to receive data.....	2-114
4.5 Troubleshooting for Network Problems	2-115
4.5.1 Cannot make a print through network connection	2-115
4.6 Troubleshooting for Control Panel Problems.....	2-116
4.6.1 Nothing is displayed on the LCD	2-116
4.6.2 Unable to perform panel operation	2-117
4.6.3 The machine does not enter the ready state when the power is turned ON..	2-118
4.7 Troubleshooting for Toner Cartridge and Drum Unit Problems.....	2-119
4.7.1 New toner not detected	2-119
4.7.2 Toner cartridge not detected.....	2-119
4.7.3 Toner replacement message displayed on LCD is not cleared	2-119
4.7.4 Drum error	2-120
4.7.5 Drum replacement message displayed on LCD is not cleared.....	2-120
4.8 Troubleshooting for Fuser Unit Problems	2-121
4.8.1 Fuser unit failure.....	2-121
4.9 Troubleshooting for Laser Unit Problems	2-121
4.9.1 Laser unit failure	2-121
4.10 Troubleshooting for PCB Problems	2-122
4.10.1 Main PCB failure.....	2-122
4.10.2 Full memory.....	2-122
4.10.3 Problem of print restriction/ID authentication.....	2-122
4.11 Document Feeding Problems	2-123

4.11.1 No feeding	2-123
4.11.2 Double feeding.....	2-123
4.11.3 Paper jam	2-124
4.11.4 Document becomes wrinkled.....	2-126
4.11.5 Document size cannot be correctly detected.....	2-126
4.12 Scanning Image Defect Troubleshooting.....	2-127
4.12.1 Image defect examples	2-127
4.12.2 Troubleshooting image defect	2-127
4.13 Troubleshooting of FAX Functions.....	2-131
4.13.1 FAX can't send it.....	2-131
4.13.2 FAX cannot be received	2-132
4.13.3 No bell ring	2-132
4.13.4 A communication error occurs.....	2-132
4.13.5 Receive buffer full during receiving into memory.....	2-133
4.14 Troubleshooting for Other Problems.....	2-133
4.14.1 Cannot make print	2-133
4.14.2 Problem of USB direct interface	2-133
4.14.3 Cannot update firmware	2-134
4.14.4 The machine is not turned ON.....	2-134

CHAPTER 3 DISASSEMBLY AND ASSEMBLY

1. SAFETY PRECAUTIONS	3-1
2. PACKING.....	3-2
3. SCREW CATALOGUE	3-3
4. SCREW TORQUE LIST	3-4
5. LUBRICATION	3-7
6. OVERVIEW OF GEARS.....	3-9
7. HARNESS ROUTING	3-10
8. DISASSEMBLY FLOW.....	3-26
9. DISASSEMBLY PROCEDURE	3-28
9.1 Lift Gear 46/Gear Z19M10.....	3-29
9.2 Back Cover/Back Cover Stopper Arm L/Back Cover Stopper Arm R	3-30
9.3 Fuser Cover ASSY	3-33
9.4 Cleaner Pinch Roller S ASSY.....	3-35
9.5 Fuser Unit.....	3-37

9.6 Cord Hook	3-40
9.7 Side Cover L.....	3-41
9.8 Side Cover R	3-45
9.9 Duplex Tray	3-49
9.10 MP Cover ASSY/MP Paper Guide ASSY	3-50
9.11 MP Link L/MP Link R	3-53
9.12 Front Cover.....	3-54
9.13 Front Cover Release Button/Front Cover Release Button Spring	3-56
9.14 Support Flap	3-58
9.15 Pull Arm L/Pull Arm R (A4 Model Only).....	3-59
9.16 Back Cover Upper (Legal Model Only).....	3-60
9.17 ADF Unit/Hinge ASSY L/Hinge R/Hinge R Support	3-61
9.18 ADF Document Output Support Flap.....	3-73
9.19 ADF Document Support	3-73
9.20 ADF Cover ASSY	3-74
9.21 Gear Cover	3-75
9.22 Separation Roller	3-77
9.23 ADF Separation Pad Holder (A4 Model Only)	3-79
9.24 ADF Separation Pad/Separation Support Film (Legal Model Only).....	3-81
9.25 ADF Separation Spring Holder (Legal Model Only)	3-84
9.26 CIS Spacer	3-86
9.27 Second Side CIS Flat Cable/Second Side CIS Unit	3-88
9.28 ADF Cover/Document Detection Sensor PCB ASSY/ First Side Document Scanning Position Sensor PCB ASSY/ Second Side Document Scanning Position Sensor PCB ASSY (Duplex Scanning Model Only)	3-95
9.29 Document Feed Roller ASSY 2	3-100
9.30 Eject Film	3-102
9.31 ADF Motor	3-104
9.32 Document Cover ASSY	3-107
9.33 Control Panel ASSY/Document Scanner Unit	3-108
9.34 Panel PCB Unit.....	3-110
9.35 LCD	3-113
9.36 Touch Panel ASSY	3-114
9.37 NFC PCB ASSY (Model with NFC only)/Panel Cover ASSY	3-115
9.38 First Side CIS Unit/First Side CIS Flat Cable	3-116
9.39 Joint Film (A4 Model Only)	3-121
9.40 Joint Film2 (Single-side Scanning Model Only).....	3-122
9.41 Joint Cover Top.....	3-123
9.42 Modem PCB ASSY/Modem Flat Cable	3-128

9.43 Back Cover Upper (A4 Model Only)	3-133
9.44 Joint Cover USB ASSY	3-134
9.45 Wireless LAN PCB	3-136
9.46 Main PCB ASSY	3-137
9.47 Laser Unit Flat Cable/Laser Unit	3-139
9.48 Front Cover Sensor	3-143
9.49 Process Drive Unit/Fuser Drive Gear Z25	3-144
9.50 Main Drive Unit	3-150
9.51 Develop Release Drive Unit	3-151
9.52 Develop Release Sensor PCB ASSY	3-152
9.53 Toner/New Sensor PCB ASSY	3-153
9.54 Fuser Fan	3-154
9.55 Paper Eject ASSY	3-155
9.56 Toner Filter ASSY	3-156
9.57 Paper Eject Origin Sensor	3-157
9.58 Back Cover Sensor ASSY	3-159
9.59 Eject Sensor PCB ASSY	3-160
9.60 Registration Mark Sensor Unit.....	3-161
9.61 Power Fan	3-162
9.62 Low-voltage Power Supply PCB Unit	3-163
9.63 MP Paper Empty Actuator A ASSY/MP Paper Empty Actuator B	3-166
9.64 MP Paper Empty/Registration Front Sensor PCB ASSY	3-172
9.65 Paper Feed Unit/Joint Pin.....	3-174
9.66 Registration Front/Rear Sensor PCB ASSY	3-178
9.67 T1 Paper Feed Sensor PCB ASSY	3-179
9.68 High-voltage Power Supply PCB ASSY	3-182
9.69 Air Duct Film	3-185
9.70 Blower.....	3-186
10. DISASSEMBLY PROCEDURE (LT-320CL/LT-325CL).....	3-187
10.1 T2 Paper Tray Unit	3-187
10.2 T2 Cover Rear	3-188
10.3 T2 Cover Left	3-189
10.4 T2 Cover Right	3-190
10.5 T2 Relay PCB ASSY	3-191
10.6 T2 Paper Feed Frame Unit/T2 Edge Actuator	3-192

CHAPTER 4 ADJUSTMENTS AND UPDATING OF SETTINGS, REQUIRED AFTER PARTS REPLACEMENT

- 1. IF YOU REPLACE THE MAIN PCB ASSY4-1**
 - 1.1 Installing the Firmware (Sub Firmware, Panel Firmware, Main Firmware, and High-voltage Firmware) 4-2
 - 1.1.1 Checking firmware version 4-2
 - 1.1.2 Installing the firmware..... 4-3
 - 1.2 Initializing the EEPROM of the Main PCB ASSY (Function code 01) 4-4
 - 1.3 Setting the Serial Number (Function code 80) 4-5
 - 1.4 Restore Machine Information (Function code 41) 4-5
 - 1.5 Setting by Country (Function code 74) 4-5
 - 1.6 Motor Reset (Function code 57) 4-5
 - 1.7 Continuous Adjustments of Density and Registration Sensor (Function code 73) 4-6
 - 1.8 Acquisition of White Level Data (Function code 55) 4-6
 - 1.9 Adjustment of Touch Panel (Function code 61) 4-6
 - 1.10 Restoration of States at Factory Shipment 4-6
- 2. IF YOU REPLACE THE REGISTRATION MARK SENSOR UNIT4-7**
 - 2.1 Continuous Adjustments of Density and Registration Sensor (Function code 73) 4-7
- 3. IF YOU REPLACE THE LOW-VOLTAGE POWER SUPPLY PCB UNIT ..4-8**
 - 3.1 Reset of Irregular Power Supply Detection Counter of Low-Voltage Power Supply PCB (Reset Counters for Parts (Function code 88)) 4-8
- 4. IF YOU REPLACE THE PROCESS DRIVE UNIT.....4-9**
 - 4.1 Motor Reset (Function code 57) 4-9
- 5. IF YOU REPLACE THE HIGH-VOLTAGE POWER SUPPLY PCB ASSY4-10**
 - 5.1 Installing the Firmware..... 4-10
 - 5.1.1 Checking firmware version 4-10
 - 5.1.2 Installing the firmware..... 4-10
 - 5.2 Continuous Adjustments of Density and Registration Sensor (Function code 73)..... 4-10
- 6. IF YOU REPLACE THE LCD PANEL ASSY OR PANEL CONTROL PCB ASSY4-11**
 - 6.1 Installing the Firmware..... 4-11
 - 6.1.1 Checking firmware version 4-11
 - 6.1.2 Installing the firmware..... 4-11
 - 6.2 Adjustment of Touch Panel (Function code 61) 4-11
 - 6.3 Operational Check of LCD (Function code 12)..... 4-11

7. IF YOU REPLACE THE LASER UNIT	4-12
7.1 Continuous Adjustments of Density and Registration Sensor (Function code 73).....	4-12
7.2 Counter Reset of Laser Unit (Reset Counters for Parts (Function code 88))	4-12
8. IF YOU REPLACE THE FIRST SIDE CIS UNIT, DOCUMENT SCANNER UNIT	4-13
8.1 Acquisition of White Level Data (Function code 55).....	4-13
8.2 Scanning and Printing Check	4-13
9. IF YOU REPLACE THE ADF UNIT, SECOND SIDE CIS UNIT.....	4-14
9.1 Acquisition of White Level Data (Function code 55) (Duplex Scanning Model Only).....	4-14
9.2 Scanning and Printing Check	4-14
10. IF YOU REPLACE THE FUSER UNIT/PF KIT 1, 2, AND MP	4-15
10.1 Counter Reset of Fuser Unit or PF Kit 1, 2, and MP (Reset Counters for Parts (Function code 88)).....	4-15

CHAPTER 5 SERVICE FUNCTIONS

1. MAINTENANCE MODE.....	5-1
1.1 How to Enter the Maintenance Mode	5-1
1.1.1 How to Enter the Maintenance Mode Exclusive to Service Personnel.....	5-1
1.1.2 How to Enter the End User-accessible Maintenance Mode	5-2
1.2 List of Maintenance-mode Functions.....	5-3
1.3 Detailed Description of Maintenance-mode Functions	5-5
1.3.1 EEPROM parameter initialization (Function code 01, 91)	5-5
1.3.2 Printout of scanning compensation data (Function code 05).....	5-6
1.3.3 ADF performance test (Function code 08)	5-8
1.3.4 Monochrome image quality test pattern (Function code 09).....	5-9
1.3.5 Worker switch (WSW) setting and printout (Function code 10, 11)	5-10
1.3.6 Operational check of LCD (Function code 12)	5-14
1.3.7 Operational check of control panel key (Function code 13).....	5-15
1.3.8 Software version check (Function code 25).....	5-16
1.3.9 “One Push Demo” setting (Function code 28).....	5-17
1.3.10 Operational check of sensors (Function code 32).....	5-18
1.3.11 LAN connection status display (Function code 33).....	5-22
1.3.12 EEPROM Dump Print (Function code 40).....	5-23
1.3.13 Backup of machine information (Function code 41)	5-24
1.3.14 PC print function setting (Function code 43)	5-26

1.3.15 Changing return value of USB No./Switching Dither Pattern/ Switching of ON/OFF of DirectPrint Color mode-Improve Gray Color/ Switching of timing to execute Auto Registration/ Adjusting left-end print start position on second side in duplex printing/ Change of the transfer current setting/Change of ghost reduction setting (Function code 45).....	5-29
1.3.16 Set country/language (Function code 52).....	5-33
1.3.17 Transfer of received fax data and log information (Function code 53)	5-34
1.3.18 Fine adjustment of scan positions (Function code 54)	5-36
1.3.19 Acquisition of white level data and setting of CIS scanning area (Function code 55).....	5-37
1.3.20 Motor reset (Function code 57)	5-38
1.3.21 Adjustment of touch panel (Function code 61)	5-39
1.3.22 Adjustment of color registration (Adjustment of inter-color position alignment) (Function code 66)	5-40
1.3.23 Continuous print test (Function code 67).....	5-44
1.3.24 Laser unit test pattern print (Function code 68).....	5-48
1.3.25 Frame pattern print (One-sided) (Function code 69)	5-49
1.3.26 Frame pattern print (Two-sided) (Function code 70)	5-50
1.3.27 Color test pattern (Function code 71)	5-51
1.3.28 Sensitivity adjustment of density sensor (Function code 72).....	5-54
1.3.29 Continuous adjustments of density and registration sensor (Function code 73).....	5-55
1.3.30 Setting by country (Function code 74).....	5-56
1.3.31 Printout of maintenance information (Function code 77).....	5-59
1.3.32 Operational check of fans (Function code 78).....	5-61
1.3.33 Display of device log information (Function code 80).....	5-62
1.3.34 Display of device error codes (Function code 82)	5-66
1.3.35 Developing bias voltage correction (Function code 83).....	5-67
1.3.36 Sending of communication log information to telephone line (Function code 87).....	5-68
1.3.37 Reset counters for parts (Function code 88)	5-69
1.3.38 Exit from the maintenance mode (Function code 99).....	5-69

2. OTHER SERVICE FUNCTIONS.....5-70

2.1 Printing of Communication List.....	5-70
2.2 Drum Cleaning.....	5-71
2.3 Counter Reset of Consumable Parts (Drum unit/Belt unit).....	5-72

CHAPTER 6 WIRING DIAGRAM

1. WIRING DIAGRAM6-1

CHAPTER 7 PERIODICAL MAINTENANCE

1. SAFETY PRECAUTIONS7-1

2. PERIODICAL REPLACEMENT PARTS7-2

- 2.1 Procedures to Replace Periodical Replacement Parts..... 7-2
 - 2.1.1 Fuser unit..... 7-3
 - 2.1.2 Laser unit..... 7-12
 - 2.1.3 PF kit 1 7-42
 - 2.1.4 PF kit 2 7-45
 - 2.1.5 PF kit MP 7-48

APPENDIX 1 SERIAL NUMBERING SYSTEM







APPENDIX 2 DELETION OF USER SETTING INFORMATION

APPENDIX 3 INSTALLING THE MAINTENANCE PRINTER DRIVER

SAFETY INFORMATION









■ Definitions of Warnings, Cautions, Notes and Memos

The following conventions are used in this manual:

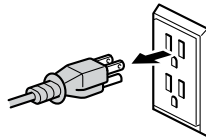
Mark	Contents
	WARNING indicates a potentially hazardous situation which, if not avoided, could result in death or serious injuries.
	CAUTION indicates a potentially hazardous situation which, if not avoided, may result in minor or moderate injuries.
	IMPORTANT indicates a potentially hazardous situation which, if not avoided, may result in damage to property or loss of product functionality.
	Prohibition icons indicate actions that must not be performed.
	Electrical Hazard icons alert you to possible electrical shock.
	Fire hazard icons alert you to the possibility of fire.
	Hot Surface icons warn you not to touch product parts that are hot.
Note	Notes tell you how you should respond to a situation that may arise or give tips about how the operation works with other features.
Memo	Memo tells you bits of knowledge to help understand the machine.

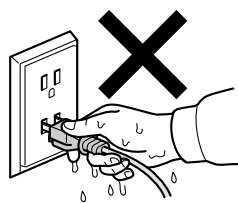
■ **To use the Machine Safely**

Please keep these instructions for later reference and read them before attempting any maintenance. If you do not follow these safety instructions, there is a possibility of a fire, electrical shock, burn or suffocation.

 WARNING
 ELECTRICAL HAZARDS <p>Failure to follow the warnings in this section may create the risk of an electrical shock. In addition, you could create an electrical short, which may create the risk of a fire.</p>
 <p>There are high voltage electrodes inside the product. Before you access the inside of the product, including for routine maintenance such as cleaning, make sure you have unplugged the telephone line cord first (MFC only) and then the power cord from the AC power outlet, as well as any telephone (RJ-11) (MFC only) or Ethernet (RJ-45) cables (Network models only) from the product. Never push objects of any kind into this product through cabinet slots, since they may touch dangerous voltage points or short out parts.</p> 
 <p>DO NOT handle the plug with wet hands.</p> 
 <p>DO NOT use this product during an electrical storm.</p>
 <p>Always make sure the plug is fully inserted. DO NOT use the product or handle the cord if the cord has become worn or frayed.</p>
  <p>DO NOT allow this product to come into contact with water. This product should not be used around standing water, including a bath tub, sink, or swimming pool; around appliances containing water, including a refrigerator; or in a wet basement.</p>



This product should be connected to an AC power source within the range indicated on the rating label. DO NOT connect it to a DC power source or inverter.



Power Cord Safety:

- This product is equipped with a 3-wire grounded plug. This plug will only fit into a grounded power outlet. This is a safety feature. If you are unable to insert the plug into the outlet, call your electrician to replace your obsolete outlet. DO NOT attempt to defeat the purpose of the grounded plug.
- Only use the power cord supplied with this product.
- This product should be positioned so that nothing pinches or constricts the power cord. DO NOT allow anything to rest on the power cord. DO NOT place this product where people may step on the cord. DO NOT place this product in a position where the cord is stretched or where strain is otherwise put on the cord. Doing so may cause the cord to become worn or frayed.
- Brother strongly recommends that you DO NOT use any type of extension cord.

(MFC only)

Use caution when installing or modifying telephone lines. Never touch telephone wires or terminals that are not insulated unless the telephone line has been unplugged from the wall jack.

Never install telephone wiring during a lightning storm. Never install a telephone wall jack in a location that is wet or may become wet, for example, near a refrigerator or other appliance that produces condensation.



- DO NOT put a toner cartridge, a toner cartridge and drum unit assembly, or a waste toner box into a fire. It could explode, resulting in injuries.
- DO NOT use flammable substances, any type of spray, or an organic solvent/liquid containing alcohol or ammonia to clean the inside or outside of the product. Doing so could cause a fire or electrical shock. Instead, use only a dry, lint-free cloth.





DO NOT attempt to operate this product when a paper jam or stray pieces of paper are inside the product. Prolonged contact of the paper with the fuser unit could cause a fire.



DO NOT use a vacuum cleaner to clean up scattered toner. Doing this might cause the toner dust to ignite inside the vacuum cleaner, potentially starting a fire. Please carefully clean the toner dust with a dry, lint-free soft cloth and dispose of it according to local regulations.



HOT SURFACE

After you have just used the product, some internal parts of the product will be extremely hot. Wait for the product to cool down before you touch the internal parts of the product.

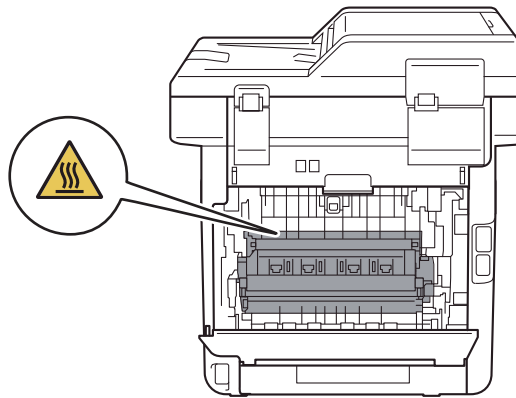

This product is heavy and weighs more than 20.0 kg. (44.1 lb). To prevent possible injuries, at least two people should lift the product. One person should hold the front of the product, and one person should hold the back, as shown in the illustration below. Be careful not to trap your fingers when you put the product down.

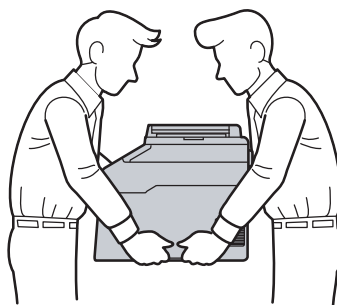

If you use a Lower Tray, DO NOT carry the product with the Lower Tray as you may be injured or cause damage to the product because it is not attached to the Lower Tray.



(DCP-L8400CDN/MFC-L8600CDW/MFC-L8650CDW ONLY)

Some areas of the product can cause injury if covers (shaded) are closed with force. Take care when placing your hand in the areas shown in the illustrations, and **DO NOT** close the covers with force.



(MFC and DCP only)

To prevent injuries, be careful not to put your fingers in the areas shown in the illustrations

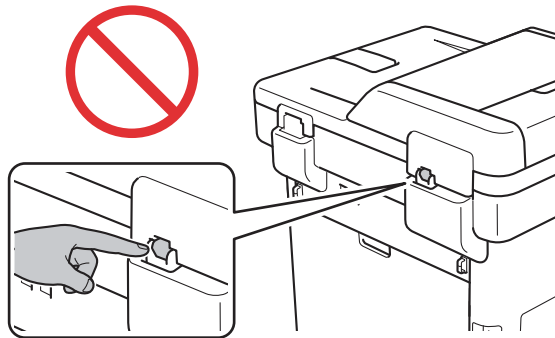

(MFC only)

When using your telephone equipment, basic safety precautions should always be followed to reduce the risk of fire, electrical shock and injury to people. These important safety precautions including the following:

- (1) **DO NOT** use this product near water or locations that may become wet, for example, near a bath tub, wash bowl, kitchen sink or washing machine, in a wet basement or near a swimming pool.
- (2) Avoid using this product during an electrical storm. There may be a remote risk of electric shock from lightning.
- (3) **DO NOT** use this product to report a gas leak in the vicinity of the leak.
- (4) Use only the power cord provided with the product.

Read all of the instructions. Save them for later reference.



(MFC only)

To reduce the risk of shock or fire, use only a No. 26 AWG or larger telecommunication line cord.

■ **Caution for Laser Product (WARNHINWEIS für Laserdrucker)**

CAUTION: In case of any trouble with the laser unit, replace the laser unit itself. To prevent direct exposure to the laser beam, do not try to open the enclosure of the laser unit.

ACHTUNG: Im Falle von Störungen der Lasereinheit muß diese ersetzt werden. Das Gehäuse der Lasereinheit darf nicht geöffnet werden, da sonst Laserstrahlen austreten können.

<Location of the scanner windows>

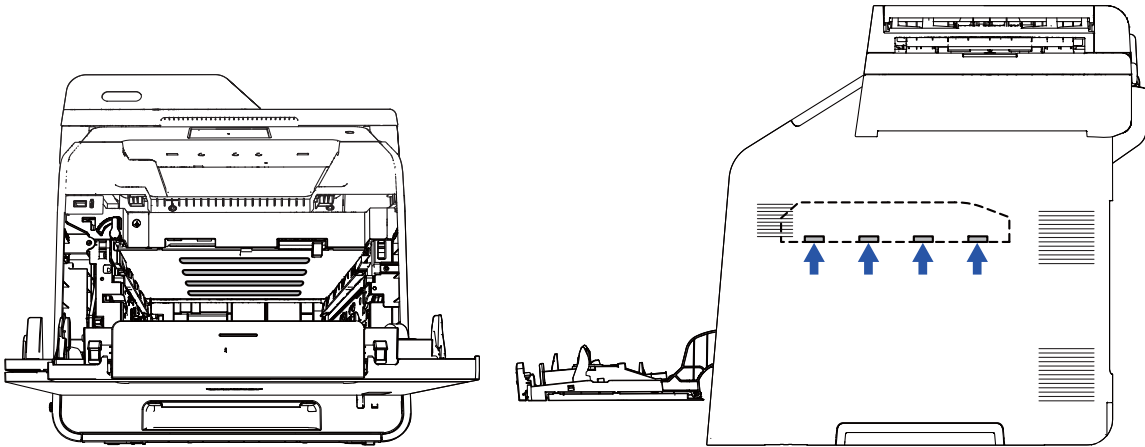

■ **Additional Information**

When servicing the optical system of the machine, be careful not to place a screwdriver or other reflective object in the path of the laser beam. Be sure to take off any personal accessories such as watches and rings before working on the machine. A reflected beam, though invisible, can permanently damage the eyes.

Since the beam is invisible, the following caution label is attached on the laser unit.



■ Standard telephone and FCC notices (MFC only)

These notices are in effect on models sold and used in the United States only.

When programming emergency numbers or making test calls to emergency numbers:

- Remain on the line and briefly explain to the dispatcher the reason for the call before hanging up.
- Perform these activities in the off-peak hours, such as early morning or late evening. This equipment complies with Part 68 of the FCC rules and the requirements adopted by the ACTA. On the backside of this equipment is a label that contains, among other information, a product identifier in the format US: AAAEQ##TXXXX. If requested, this number must be provided to the telephone company.

You may safely connect this equipment to the telephone line by means of a standard modular jack, USOC RJ11C.

A plug and jack used to connect this equipment to the premises wiring and telephone network must comply with the applicable FCC Part 68 rules and requirements adopted by the ACTA. A compliant telephone cord and modular plug is provided with this product. It is designed to be connected to a compatible modular jack that is also compliant. (See installation instructions for details.)

The REN is used to determine the number of devices that may be connected to a telephone line. Excessive RENs on a telephone line may result in the devices not ringing in response to an incoming call. In most but not all areas, the sum of RENs should not exceed five (5.0). To be certain of the number of devices that may be connected to a line, as determined by the total RENs, contact the local telephone company. For products approved after July 23, 2001, the REN for this product is part of the product identifier that has the format US:AAAEQ##TXXXX. The digits represented by ## are the REN without a decimal point (e.g., 06 is a REN of 0.6). For earlier products, the REN is separately shown on the label.

If this equipment causes harm to the telephone network, the telephone company will notify you in advance that temporary discontinuance of service may be required. But if advance notice is not practical, the telephone company will notify the customer as soon as possible. Also, you will be advised of your right to file a complaint with the FCC if you believe it is necessary.





The telephone company may make changes in its facilities, equipment, operations or procedures that could affect the operation of the equipment. If this happens the telephone company will provide advance notice in order for you to make necessary modifications to maintain uninterrupted service.

If trouble is experienced with this equipment, for repair or warranty information, please contact Brother Customer Service (see Basic User's Guide: *Brother numbers*). If the equipment is causing harm to the telephone network, the telephone company may request that you disconnect the equipment until the problem is resolved.

Connection to party line service is subject to state tariffs. Contact the state public utility commission, public service commission or corporation commission for information.

If your home has specially wired alarm equipment connected to the telephone line, ensure the installation of this equipment does not disable your alarm equipment. If you have questions about what will disable alarm equipment, call your telephone company or a qualified installer.

If you are not able to solve a problem with your product, contact Brother Customer Service (see Basic User's Guide: *Brother numbers*).

 WARNING
 <p>For protection against the risk of electrical shock, always disconnect all cables from the wall outlet before the equipment is installed, or modified.</p>
 <p>DO NOT attempt to service this product yourself. Refer all servicing to a Brother Authorized Service Center.</p>
 IMPORTANT
<ul style="list-style-type: none"> - This equipment may not be used on coin service lines provided by the telephone company or connected to party lines. - Brother cannot accept any financial or other responsibilities that may be the result of your use of this information, including direct, special or consequential damages. There are no warranties extended or granted by this document. - This product has been certified to comply with FCC standards, which are applied to the USA only. A grounded plug should be plugged into a grounded AC power outlet after checking the rating of the local power supply for the product to operate properly and safely.

■ **Legal limitations for copying (MFC and DCP only)**

Reproductions of certain documents are illegal and may result in either criminal or civil liability. The listing below is intended to be a guide rather than a complete listing of every possible prohibition. In case of doubt, we suggest that you consult with the appropriate authority or advisor with regard to the specific document.

The following documents issued by the United States/Canadian Government or any of its Agencies, States, Territories or Provinces may not be copied:

- ?Money
- Bonds or other certificates of indebtedness
- Certificates of Deposit
- Internal Revenue Stamps (canceled or uncanceled)
- Selective Service or draft papers
- Passports
- United States/Canadian Postage Stamps (canceled or uncanceled)
- Food Stamps
- Immigration Papers
- Checks or drafts drawn by Governmental agencies
- Identifying badges or insignias
- Licenses and Certificates of Title to motor vehicles, under certain State/Provincial law

Copying copyrighted works may be regulated by Federal, State or local laws. For more information, consult an appropriate authority or advisor.

CHAPTER 1 SUPPLEMENTAL SPECIFICATIONS

1.1 General

The table below shows the functional comparison between the models covered by this manual.

Model	DCP-L8400CDN	DCP-L8450CDW	MFC-L8600CDW	MFC-L8650CDW	MFC-L8850CDW	MFC-L9550CDW
LCD	81.65 mm x 45.36 mm (3.21 x 1.79 inch)	107.56 mm x 59.76 mm (4.23 x 2.35 inch)	81.65 mm x 45.36 mm (3.21 x 1.79 inch)	81.65 mm x 45.36 mm (3.21 x 1.79 inch)	107.56 mm x 59.76 mm (4.23 x 2.35 inch)	107.56 mm x 59.76 mm (4.23 x 2.35 inch)
Flatbed scanner size	A4	Legal	A4	A4	Legal	Legal
Wired/Wireless LAN	Wired	Wired/Wireless	Wired/Wireless	Wired/Wireless	Wired/Wireless	Wired/Wireless
Scanner	One-sided	Two-sided	One-sided	Two-sided	Two-sided	Two-sided
FAX	N/A	N/A	√	√	√	√

Model		DCP-L8400CDN	DCP-L8450CDW
Warm-up time	From Sleep mode	Less than 31 seconds at 73.4F (23 °C/50 %)	
	From Power OFF → ON	Less than 33 seconds at 73.4F (23 °C/50 %)	
First print time	From Ready mode	Monochrome/Full Color: Less than 15/15 seconds	
	From Sleep mode	Monochrome/Full Color: Less than 36/36 seconds	
CPU		StarSapphire 400 MHz	
Backup Clock		Up to 60 hours	
Dimensions (W x D x H)	Carton Size	637 x 545 x 649 mm (25.1 x 21.5 x 25.6 inch)	660 x 625 x 698 mm (26.0 x 24.6 x 27.5 inch)
	Machine Size	410 x 503 x 492 mm (16.1 x 19.8 x 19.4 inch)	490 x 526 x 530 mm (19.3 x 20.7 x 20.9 inch)
Weights	with carton	33.4 kg/73.6 lb (for Latin) 33.8 kg/74.5 lb (for Europe) 33.5 kg/73.9 lb (for China)	36.0 kg/79.5 lb
	without carton, with toner/drum	28.6 kg/63.0 lb (for Latin) 29.0 kg/63.9 lb (for Europe) 28.7 kg/63.0 lb (for China)	30.2 kg/66.6 lb
	without carton and toner/drum	22.9 kg/50.4 lb	24.1 kg/53.1 lb

Specifications are subject to change without prior notice.

Model		MFC-L8600CDW	MFC-L8650CDW	MFC-L8850CDW	MFC-L9550CDW
Warm-up time	From Sleep mode	Less than 31 seconds at 73.4F (23 °C/50 %)			
	From Power OFF → ON	Less than 33 seconds at 73.4F (23 °C/50 %)			
First print time	From Ready mode	Monochrome/Full Color: Less than 15/15 seconds		Monochrome/Full Color: Less than 15/15 seconds	Monochrome/Full Color: Less than 15/15 seconds
	From Sleep mode	Monochrome/Full Color: Less than 36/36 seconds		Monochrome/Full Color: Less than 36/36 seconds	Monochrome/Full Color: Less than 36/36 seconds
CPU		StarSapphire 400 MHz			
Backup Clock		Up to 60 hours			
Dimensions (W x D x H)	Carton Size	637 x 545 x 649 mm (25.1 x 21.5 x 25.6 inch)		660 x 625 x 698 mm (26.0 x 24.6 x 27.5 inch)	
	Machine Size	410 x 503 x 492 mm (16.1 x 19.8 x 19.4 inch)		490 x 526 x 530 mm (19.3 x 20.7 x 20.9 inch)	
Weights	with carton	33.6 kg/74.0 lb (for the U.S.A., Latin) 34.3 kg/75.6 lb (for Oceania, Asia)	35.2 kg/77.7 lb (for Europe) 34.9 kg/77.0 lb (for China)	36.4 kg/80.3 lb (for the U.S.A., Latin) 36.8 kg/81.2 lb (for Europe) 37.1 kg/81.9 lb (for Oceania, Asia)	36.4 kg/80.3 lb (for the U.S.A.) 37.2 kg/82.0 lb (for Europe) 37.1 kg/81.9 lb (for Oceania, Asia)
	without carton, with toner/drum	28.8 kg/63.5 lb (for the U.S.A., Latin) 29.5 kg/65.0 lb (for Oceania, Asia)	30.4 kg/67.0 lb (for Europe) 30.1 kg/66.4 lb (for China)	30.6 kg/67.4 lb (for the U.S.A., Latin) 31.0 kg/68.3 lb (for Europe) 31.3 kg/68.9 lb (for Oceania, Asia)	
	without carton and toner/drum	23.0 kg/50.8 lb	24.3 kg/53.5 lb	24.8 kg/54.7 lb	

Specifications are subject to change without prior notice.

1.2 Network Connectivity

Model		DCP-L8400CDN	DCP-L8450CDW
Wired network	Network node type	NC-8600h type2	
Wireless network	Network node type	N/A	NC-8200w type2

Specifications are subject to change without prior notice.

Model		MFC-L8600CDW	MFC-L8650CDW	MFC-L8850CDW	MFC-L9550CDW
Wired network	Network node type	NC-8600h type2			
Wireless network	Network node type	NC-8200w type2			

Specifications are subject to change without prior notice.

1.3 Service Information

Model		DCP-L8400CDN	DCP-L8450CDW
Machine life		200,000 pages (A4/Letter size) or 5 years	
Part life (ADF)		Up to 50,000 pages or 5 years	
Part life (Document Scanner Unit)		Up to 50,000 pages or 5 years	
MTBF		4,000 hours	
MTTR		0.5 hours	
Maximum monthly volume		Up to 40,000 pages	Up to 60,000 pages
Periodical maintenance parts	Fuser Unit	Up to 100,000 pages	
	Laser Unit	Up to 100,000 pages	
	PF kit 1	Up to 100,000 pages	
	PF kit 2	Up to 100,000 pages	
	PF kit MP	Up to 50,000 pages	

* As for replacement of the periodical maintenance parts, refer to **"PERIODICAL MAINTENANCE"** in Chapter 7.

Specifications are subject to change without prior notice.

Model		MFC-L8600CDW	MFC-L8650CDW	MFC-L8850CDW	MFC-L9550CDW
Machine life		200,000 pages (A4/Letter size) or 5 years			
Part life (ADF)		Up to 50,000 pages or 5 years			
Part life (Document Scanner Unit)		Up to 50,000 pages or 5 years			
MTBF		4,000 hours			
MTTR		0.5 hours			
Maximum monthly volume		Up to 40,000 pages	Up to 60,000 pages	Up to 75,000 pages	
Periodical maintenance parts	Fuser Unit	Up to 100,000 pages			
	Laser Unit	Up to 100,000 pages			
	PF kit 1	Up to 100,000 pages			
	PF kit 2	Up to 100,000 pages			
	PF kit MP	Up to 50,000 pages			

* As for replacement of the periodical maintenance parts, refer to **"PERIODICAL MAINTENANCE"** in Chapter 7.

Specifications are subject to change without prior notice.

1.4 Supplies

Model			DCP-L8400CDN	DCP-L8450CDW	
Toner cartridge	Starter Toner *1	Black	Approximately 2,500 pages (except for China) Approximately 4,000 pages (for China)		
		Cyan, Magenta, Yellow	Approximately 1,500 pages (except for China) Approximately 3,500 pages (for China)		
	Standard Toner	Black	Approximately 2,500 pages (except for China) N/A (for China)		
		Cyan, Magenta, Yellow	Approximately 1,500 pages (except for China) N/A (for China)		
	High Capacity Toner	Black	Approximately 4,000 pages		
		Cyan, Magenta, Yellow	Approximately 3,500 pages		
	Super High Capacity Toner	Black	Approximately 6,000 pages (except for Europe) N/A (for Europe)		
		Cyan, Magenta, Yellow	Approximately 6,000 pages (except for Europe) N/A (for Europe)		
	When printing A4/Letter size one sided pages in accordance with ISO/IEC 19798 Self life: 2 years without opening (6 months after opening)				

*1 Toner supplied with the machine.

Specifications are subject to change without prior notice.

Model			MFC- L8600CDW	MFC- L8650CDW	MFC- L8850CDW	MFC- L9550CDW	
Toner cartridge	Starter Toner ^{*1}	Black	Approximately 2,500 pages (except for China) Approximately 4,000 pages (for China)		Approximately 6,000 pages (except for Asia) Approximately 2,500 pages (for Asia)		
		Cyan, Magenta, Yellow	Approximately 1,500 pages (except for China) Approximately 3,500 pages (for China)		Approximately 6,000 pages (except for Asia) Approximately 1,500 pages (for Asia)		
	Standard Toner	Black	Approximately 2,500 pages (except for China) N/A (for China)		N/A (except for Asia) Approximately 2,500 pages (for Asia)		
		Cyan, Magenta, Yellow	Approximately 1,500 pages (except for China) N/A (for China)		N/A (except for Asia) Approximately 1,500 pages (for Asia)		
	High Capacity Toner	Black	Approximately 4,000 pages (except for Asia) N/A (for Asia)		N/A		
		Cyan, Magenta, Yellow	Approximately 3,500 pages (except for Asia) N/A (for Asia)		N/A		
	Super High Capacity Toner	Black	Approximately 6,000 pages (except for the U.S.A., Oceania, Europe) N/A (for the U.S.A., Oceania, Europe)	Approximately 6,000 pages (except for the U.S.A., Oceania) N/A (for the U.S.A., Oceania)		Approximately 6,000 pages (except for Asia) N/A (for Europe)	
		Cyan, Magenta, Yellow	Approximately 6,000 pages (except for the U.S.A., Oceania, Europe) N/A (for the U.S.A., Oceania, Europe)	Approximately 6,000 pages (except for the U.S.A., Oceania) N/A (for the U.S.A., Oceania)		Approximately 6,000 pages (except for Europe) N/A (for Europe)	
	When printing A4/Letter size one sided pages in accordance with ISO/IEC 19798 Self life: 2 years without opening (6 months after opening)						

*1 Toner supplied with the machine.

Specifications are subject to change without prior notice.

Model	All Models
Drum unit	Life expectancy: Approximately 25,000 pages (1 page/job) The life expectancy varies according to the use condition. Shelf life: 2 years
The shelf life of toner cartridge and drum unit is guaranteed under the normal condition as below; (Temperature) Normal condition: 0 to 40 °C * Storage condition at the temperature of 40 to 50 °C: Up to 5 days * Storage condition at the temperature of -20 to 0 °C: Up to 5 days (Humidity) Normal condition: 35 to 85 % (without condensation) * Storage condition at the humidity of 85 to 95 %: Up to 5 days (without condensation) * Storage condition at the humidity of 10 to 35 %: Up to 5 days (without condensation)	
Belt unit	Life expectancy: Approximately 50,000 pages (5 page/job) Life expectancy: Approximately 20,000 pages (1 page/job) The life expectancy varies according to the use condition.
Waste toner box	Life expectancy: Approximately 50,000 pages/waste toner box.

Specifications are subject to change without prior notice.

1.5 Paper

1.5.1 Media specifications for ADF

Model	All Models
Paper Input	ADF Plain Paper, Recycled Paper
Media weight	ADF 64 to 90 g/m ² (17 to 24 lb)
Media size	ADF Width 147.3 to 215.9 mm, Length 147.3 to 355.6 mm (Width 5.8" to 8.5", Length 5.8" to 14.0")

Specifications are subject to change without prior notice.

1.6 Telephone

Model	All Models
Handset	N/A

Specifications are subject to change without prior notice.

1.7 FAX (Only for the models with FAX function)

Model		DCP-L8400CDN	DCP-L8450CDW
Modem Speed		N/A	
Transmission speed		N/A	
ITU-T group		N/A	
Color FAX	Sending	N/A	
	Receiving	N/A	
Internet FAX (ITU T.37 simple mode)		N/A	

Specifications are subject to change without prior notice.

Model		MFC- L8600CDW	MFC- L8650CDW	MFC- L8850CDW	MFC- L9550CDW
Modem Speed		33,600 bps (Fax)			
Transmission speed		Approximately 2.5 seconds (ITU-T Test Chart, Std resolution, JBIG)			
ITU-T group		Super G3			
Color FAX	Sending	N/A			
	Receiving	N/A			
Internet FAX (ITU T.37 simple mode)		Yes (Download only)		Yes	

Specifications are subject to change without prior notice.

1.8 Copy

Model		DCP-L8400CDN	DCP-L8450CDW
Copy Speed (A4/Letter)		Monochrome/Full Color: Up to 28/30 ppm	Monochrome/Full Color: Up to 30/32 ppm
First copy out time	From Ready mode and Paper tray	Monochrome/Full Color: Less than 18/20 seconds	
	From Sleep mode and Paper tray	Monochrome/Full Color: Less than 39/41 seconds	
Resolution (dpi)		1,200 x 600 dpi	
Auto duplex scanning copy		N/A	Yes

Specifications are subject to change without prior notice.

Model		MFC-L8600CDW	MFC-L8650CDW	MFC-L8850CDW	MFC-L9550CDW
Copy Speed (A4/Letter)		Monochrome/Full Color: Up to 28/30 ppm		Monochrome/Full Color: Up to 30/32 ppm	
First copy out time	From Ready mode and Paper tray	Monochrome/Full Color: Less than 18/20 seconds			
	From Sleep mode and Paper tray	Monochrome/Full Color: Less than 39/41 seconds			
Resolution (dpi)		1,200 x 600 dpi			
Auto duplex scanning copy		N/A	Yes		

Specifications are subject to change without prior notice.

1.9 Scanner

Model		DCP-L8400CDN	DCP-L8450CDW
Resolution (Optical)	FB	Maximum scanning 1,200 (main scanning) x 2,400 dpi (sub scanning)	
	ADF	Maximum scanning 1,200 (main scanning) x 600 dpi (sub scanning)	
Resolution (Interpolated)		Maximum scanning 19,200 (main scanning) x 19,200 dpi (sub scanning)	
Scanning speed	Monochrome	1.99 seconds (Letter)/ 2.12 seconds (A4)	1.68 seconds (Letter)/ 1.79 seconds (A4)
	Color	1.99 seconds (Letter)/ 2.12 seconds (A4)	1.68 seconds (Letter)/ 1.79 seconds (A4)

Specifications are subject to change without prior notice.

Model		MFC-L8600CDW	MFC-L8650CDW	MFC-L8850CDW	MFC-L9550CDW
Resolution (Optical)	FB	Maximum scanning 1,200 (main scanning) x 2,400 dpi (sub scanning)			
	ADF	Maximum scanning 1,200 (main scanning) x 600 dpi (sub scanning)			
Resolution (Interpolated)		Maximum scanning 19,200 (main scanning) x 19,200 dpi (sub scanning)			
Scanning speed	Monochrome	1.99 seconds (Letter)/ 2.12 seconds (A4)		1.68 seconds (Letter)/ 1.79 seconds (A4)	
	Color	1.99 seconds (Letter)/ 2.12 seconds (A4)		1.68 seconds (Letter)/ 1.79 seconds (A4)	

Specifications are subject to change without prior notice.

CHAPTER 2 ERROR INDICATION AND TROUBLESHOOTING

1. INTRODUCTION

Troubleshooting is the countermeasure procedures that the service personnel should follow if an error or malfunction occurs with the machine. It is impossible to anticipate all of the possible troubles which may occur in future and determine the troubleshooting procedures, so this chapter covers some sample troubles. However, those samples will help the service personnel pinpoint and repair other defective elements.

1.1 Precautions

Be sure to observe and follow all the precautions to prevent any secondary problems from happening during troubleshooting.

- (1) Always turn off the power and unplug the power cable before removing any covers or PCBs, adjusting the machine and so on. If you need to take voltage measurements with the power switched on, take the greatest of care not to receive an electric shock.
- (2) When connecting or disconnecting cable connectors, make sure that you hold the connector body and not the cables.
- (3) Static electricity charged in your body may damage electronic parts. Before handling the PCBs, touch a metal portion of the machine to discharge static electricity charged in your body. When transporting PCBs, be sure to wrap them in conductive sheets. When replacing the PCBs, put on a grounding wrist band and perform the job on a antistatic mat. Also take care not to touch the conductor sections on the flat cables.
- (4) Follow the warning by all means.

WARNING

Hazard labels as shown below are attached to the machine. Fully understand the descriptions on the hazard labels and observe them during troubleshooting. Take extreme care not to remove or damage the hazard labels.

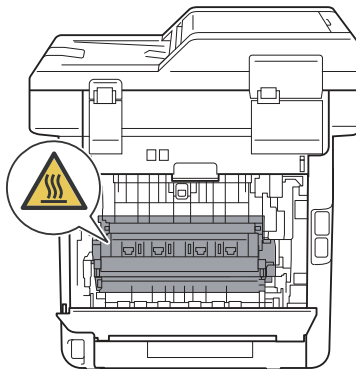

 **WARNING**

DO NOT use any flammable spray or flammable solvent such as alcohol, benzine, or thinner in or around the machine. Otherwise a fire or electric shock may result.



- (5) Check again that the portions and parts repaired or removed during the repair work function properly when the repair is completed.

1.2 Checks before Commencing Troubleshooting

Check the following items before attempting to repair the machine.

■ Operating environment

- (1) The machine is placed on a flat, stable surface.
- (2) The machine is used in a clean environment where the temperature is between 10 °C (50 °F) and 32.5 °C (90.5 °F) and the relative humidity is maintained between 20 % and 80 %.
- (3) Ensure the machine is not exposed to direct sunlight, excessive heat, moisture, or dust.
- (4) Keep the machine horizontal when you carry it. To prevent injuries when moving or lifting this machine, make sure to use at least two people.

■ Power supply

- (1) The AC input power supply described on the rating plate of the machine should be within ± 10 % of the rated voltage.
- (2) The AC input power supply is within the regulated value.
- (3) The cables and harnesses are connected correctly.
- (4) The fuses are not blown.

■ Paper

- (1) A recommended type of paper is being used.
- (2) The paper is not damp.
- (3) The paper is not short-grained paper or acid paper.

■ Consumable parts

- (1) The drum unit (including the toner cartridge) is installed correctly.
- (2) The belt unit and waste toner box are installed correctly.

■ Others

- (1) Condensation

When the machine is moved from a cold place into a warm room, condensation may occur inside the machine, causing various problems as listed below.

- Condensation on the surface of optical devices such as the scanner windows, lens, reflecting mirror, and protection glass, etc, may cause light print image.
- If the exposure drum is cold, the electrical resistance of the photosensitive layer is increased, making it impossible to obtain the correct contrast when printing.
- Condensation on the charge unit may cause corona charge leakage.
- Condensation on the plate and separation pad may cause paper feed problems.

If condensation has occurred, leave the machine for at least two hours to allow it to reach room temperature.

If the drum unit is unpacked soon after it is moved from a cold place to a warm room, condensation may occur inside the unit which may cause incorrect images. Instruct the user to allow the unit to come to room temperature before unpacking it. This will take one or two hours.

- (2) Low temperature

The motor may not drive normally under the low temperature environment. This is due to there being too much load to drive each unit. In this case, increase the room temperature.

■ Cleaning

Use a soft dry lint-free cloth.



WARNING

DO NOT use any flammable spray or flammable solvent such as alcohol, benzene, or thinner to clean the machine. **DO NOT** use these articles near the machine.



2. OVERVIEW

2.1 Cross-section Drawing

2.1.1 Printer part

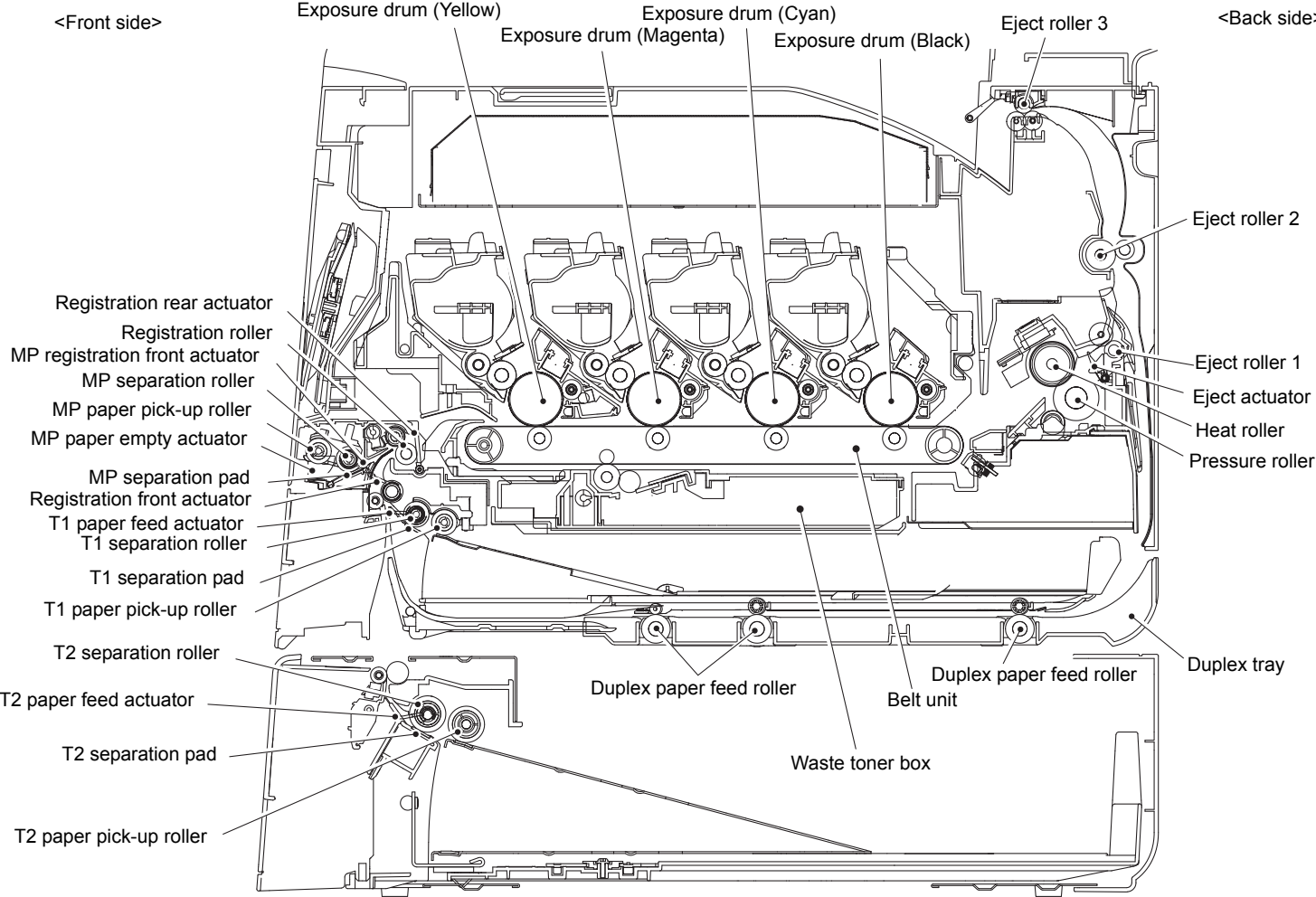

Fig. 2-1

2.1.2 Scanning part

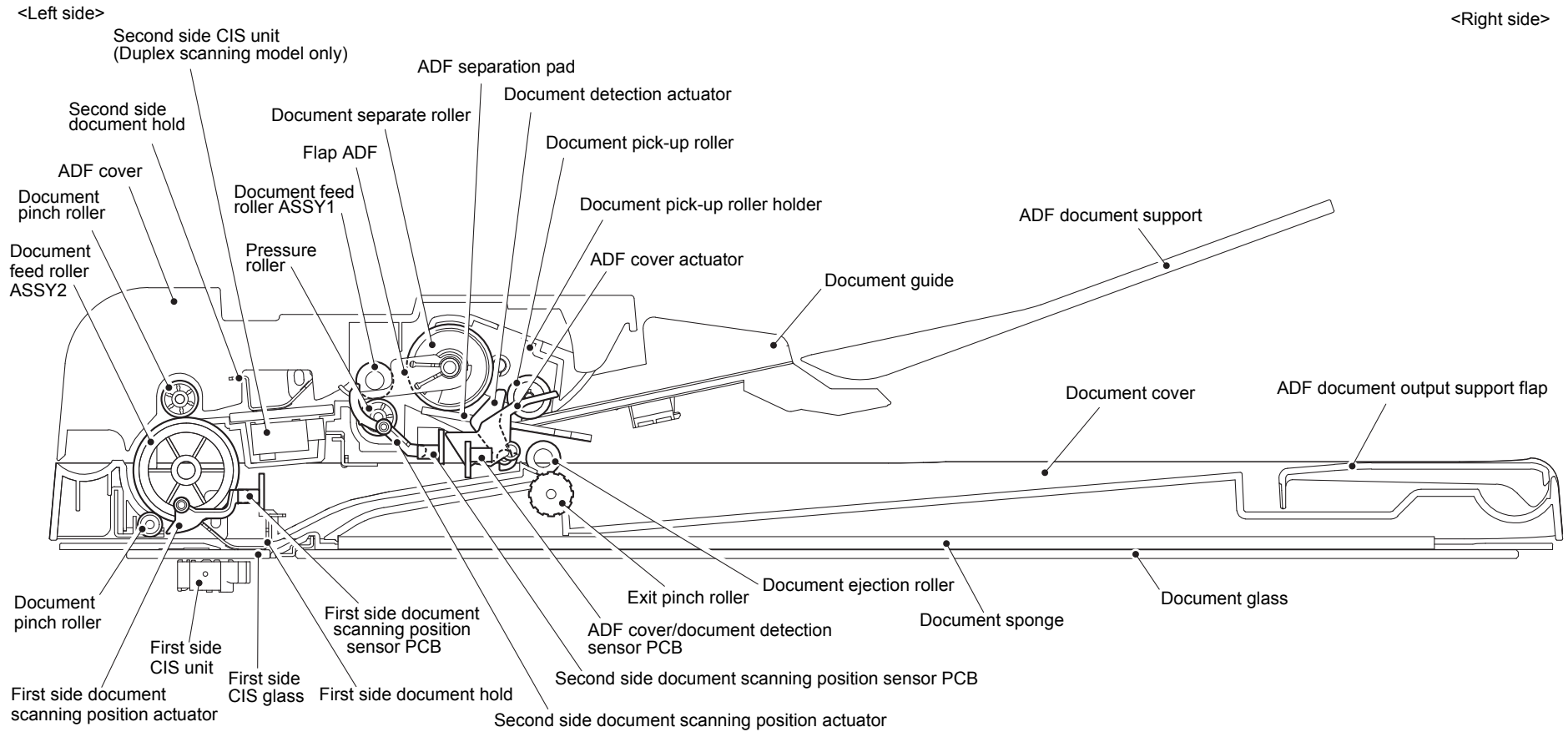

Fig. 2-2

2.2 Paper Feeding

2.2.1 Printer part

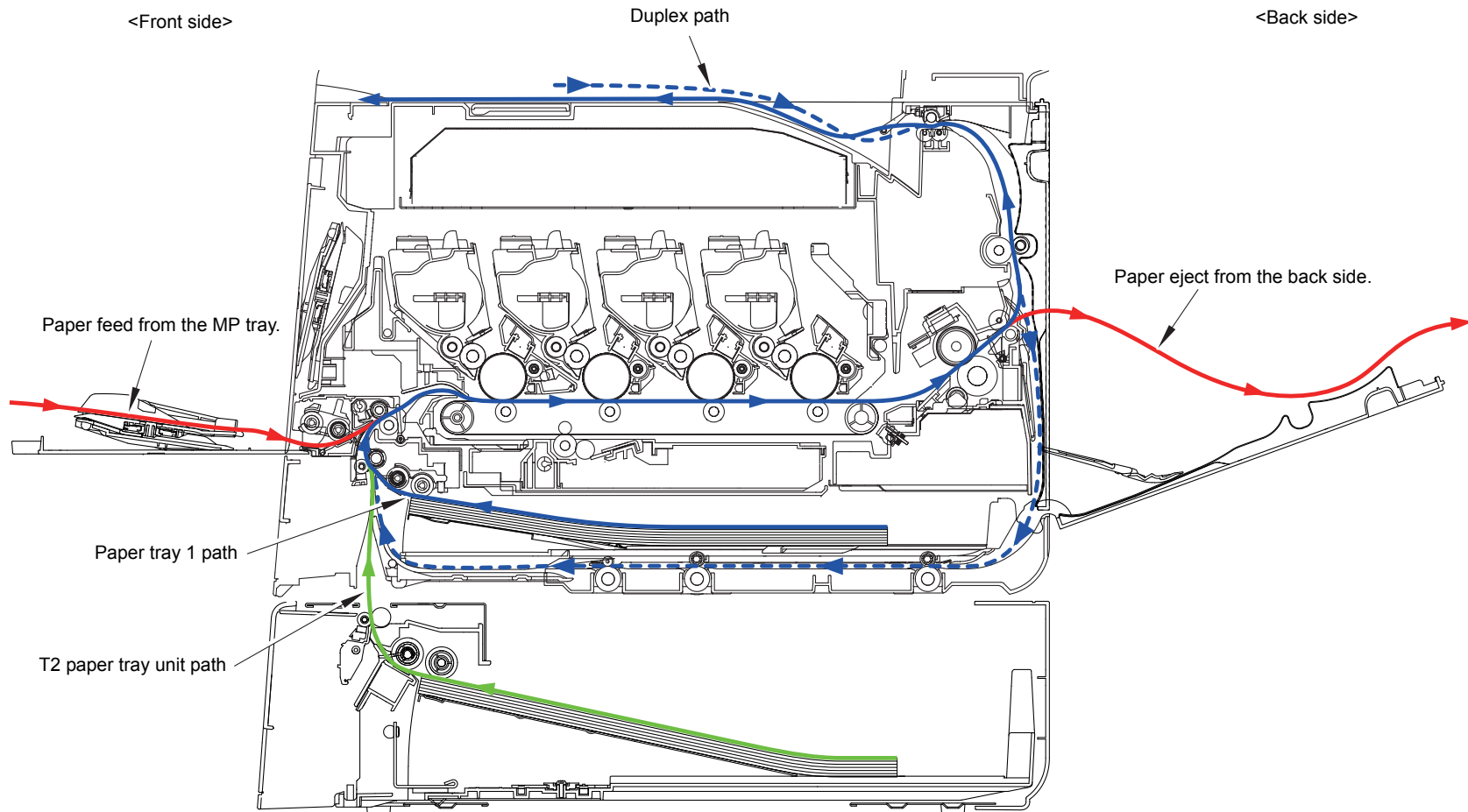

Fig. 2-3

2.2.2 Scanning part

<Left side>

<Right side>

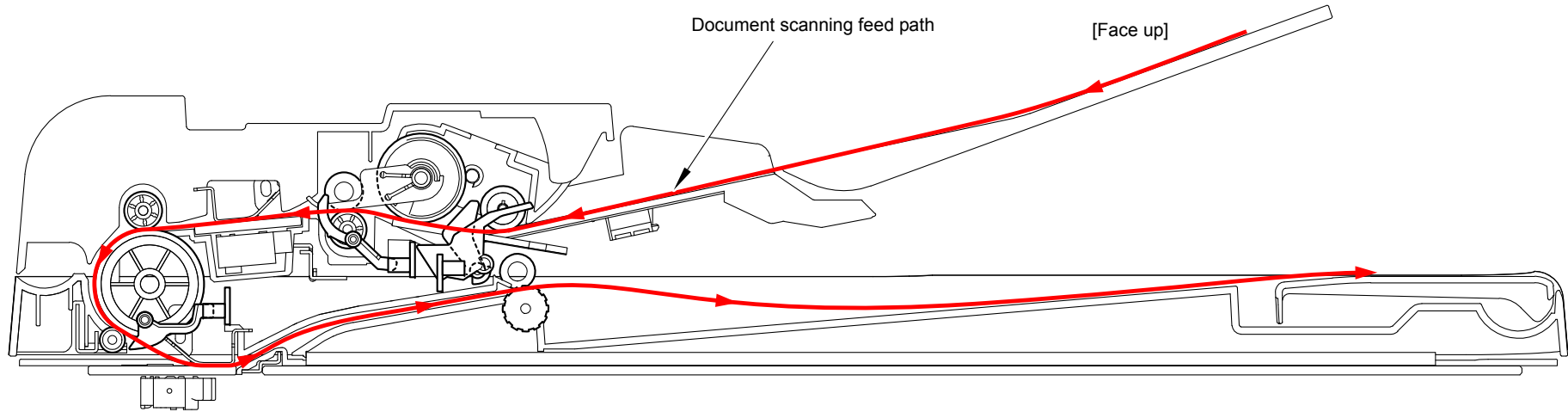

Fig. 2-4

2.3 Operation of Each Part

Part name	Operation
T1 paper pick-up roller	Feed the paper from the paper tray 1 to T1 separation roller.
T1 separation roller, T1 separation pad	Separates the paper fed from paper tray 1 into single sheets.
T1 paper feed actuator (T1 paper feed sensor)	Detect whether or not the paper tray 1 is installed (open or closed). Detect the paper jam of front part.
Registration front actuator (Registration front sensor)	Detect the front edge of paper and control the drive of the registration roller. Detect the paper jam of front part. Detect whether or not the paper is fed from the paper tray 1.
Registration roller	Hit the front edge of the paper to the stopped registration roller and the inclination of the paper is corrected. After correction is made, the registration roller rotates to feed the paper to the belt unit.
Registration rear actuator (Registration rear sensor)	Detect the passage of paper and adjust the starting position for writing on a sheet of paper. Detect the paper jam of the front part and center part. Detect the rear edge of paper and identify the paper size.
Belt unit	Feed the paper to the drum unit and transfer toner on the paper.
Heat roller, Pressure roller	Fuse and fix the toner transferred on paper by heat and pressure, and feed the paper to the eject roller 1.
Eject actuator (Eject sensor)	Detect whether or not paper is ejected from the fuser unit. In the case of the 2-sided printing, detect the rear edge of paper and adjust the timing of the eject roller 2 and 3 switching.
Eject roller 1	Feed the paper ejected from the fuser unit to the eject roller 2.
Eject roller 2	Feed the paper to the eject roller 3. In the case of the 2-sided printing, after the front of the sheet is printed and the paper is fed to the eject roller 3 up to a certain point, the eject roller 2 rotates conversely and feeds the paper fed from the eject roller 3 to the duplex tray.
Eject roller 3	Eject the paper to the face-down output tray. In the case of the 2-sided printing, after the front of the sheet is printed and the paper is fed up to a certain point, eject roller 3 rotates conversely, and the paper is fed to the eject roller 2.
Duplex paper feed roller	Feed the paper passed in the duplex tray to the registration roller.
MP paper pick-up roller	Feed the paper from the MP tray to MP separation roller.
MP separation roller, MP separation pad	Separates the paper fed from the MP tray into single sheets.
MP paper empty actuator (MP paper empty sensor)	Detect whether paper is loaded in the MP tray.
MP registration front actuator (MP registration front sensor)	Detect the front edge of paper from MP tray and control the drive of the registration roller. Detect the paper jam of MP part. Detect whether or not the paper is fed from the T2 paper tray unit.
T2 paper pick-up roller	Feed the paper from the T2 paper tray unit to T2 separation roller.

Part name	Operation
T2 separation roller, T2 separation pad	Separates the paper fed from T2 paper tray unit into single sheets.
T2 paper feed actuator (T2 paper feed sensor)	Detect whether or not the T2 paper tray unit is installed (open or closed). Detect the paper jam of front part.
Paper eject origin sensor	Detect the eject/reverse position state of the gear of the paper eject ASSY.
Document pick-up roller	Feed the documents from ADF document support to the scanning part.
Document separate roller, ADF separation pad	Separates the documents fed from ADF document support into single sheets.
Document detection actuator (Document detection sensor)	Detect whether documents are set in the ADF.
First side/Second side document scanning position actuator (Document scanning position sensor)	Detect the scanning start position of the first and second sides. Detect paper jam in the ADF.
Document ejection roller	Feed the documents to the document cover.
ADF cover sensor	Detect whether the ADF cover is opened or closed.

2.4 Block Diagram

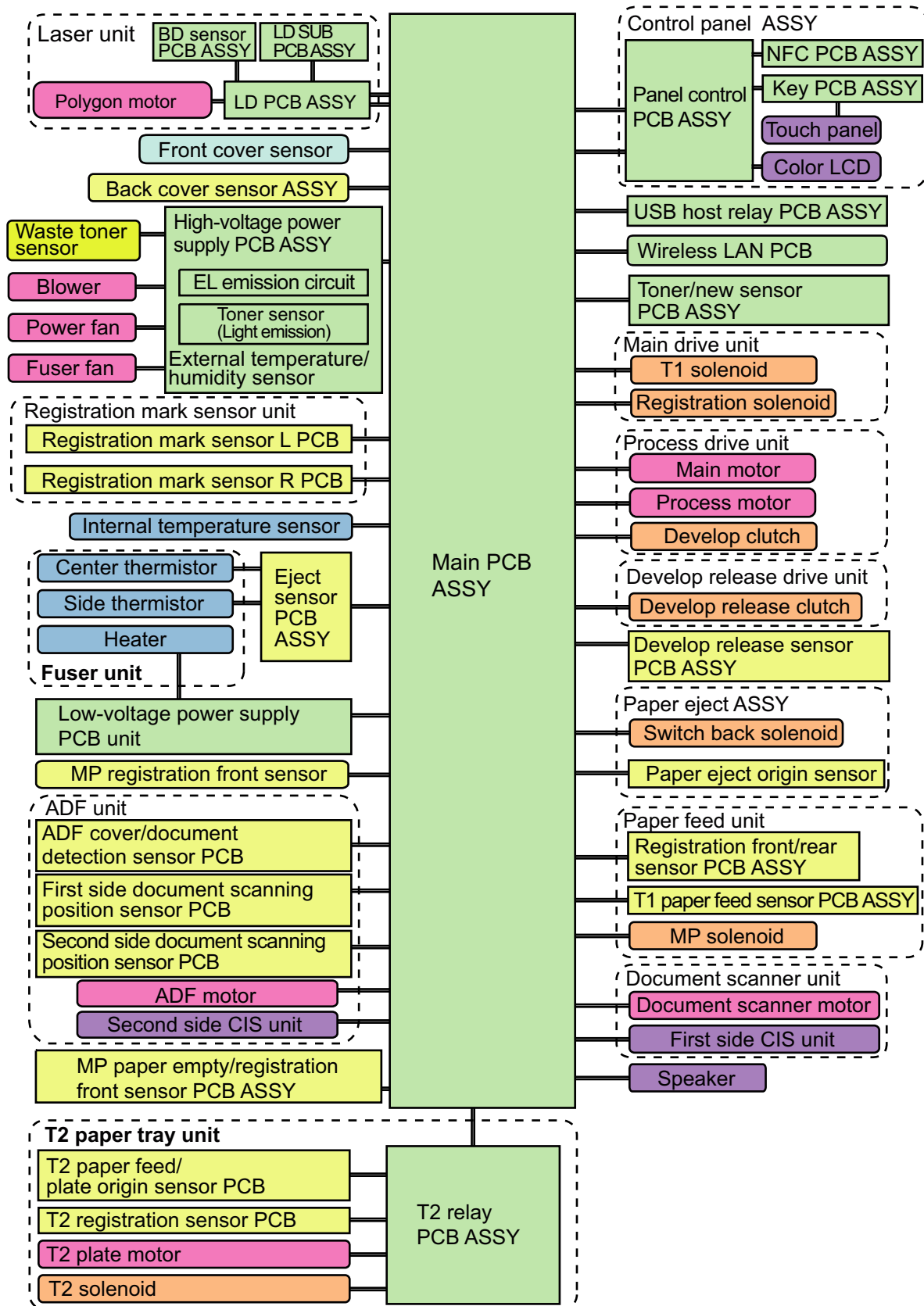

Fig. 2-5

2.5 Main Components

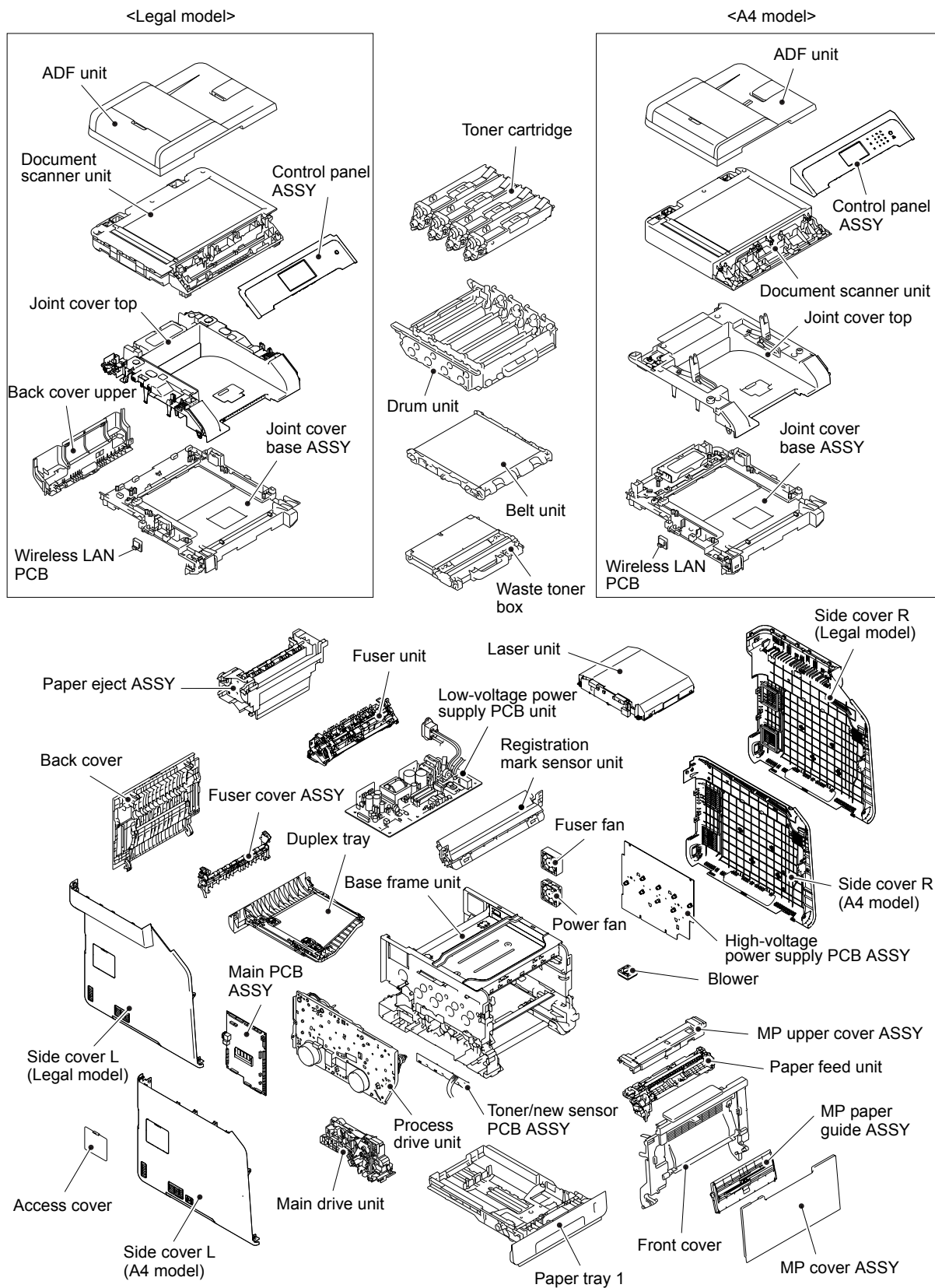

Fig. 2-6

3. ERROR INDICATIONS

This machine includes a self-diagnosis function. If the machine does not work normally it judges that an error has occurred, and indicates the corresponding error message on the LCD, which in turn helps the service personnel to quickly find out the problem.

3.1 Error Codes

The shaded errors hardly occur under normal use. They may be caused by noise around the installation site, variation in power supply voltage, or software failure.

Error Codes	Description	Refer to:	Error Codes	Description	Refer to:
0100	ASIC error or motor driver error occurred.	2-39	0502	After the temperature of the fuser unit rises to a certain level, the temperature of the center thermistor does not reach the specified temperature within the specified period of time in the next step.	2-41
0201	Synchronization signal from the main motor cannot be detected. Or the main motor speed is unstable after a set period of time.	2-39	0503	The center thermistor of the fuser unit detected a temperature higher than the specified value.	2-41
0202	Synchronization signal from the process motor cannot be detected. Or the process motor speed is unstable after a set period of time.	2-39	0504	After the center thermistor of the fuser unit was normally heated, it detected a temperature lower than the specified value.	2-41
0203	---		0505	The center thermistor of the fuser unit detected a temperature rise greater than the specified value within a set period of time.	2-41
0204	---		0506	The center thermistor of the fuser unit detected a temperature fall greater than the specified value within a set period of time.	2-41
0205	---		050A	The center thermistor or side thermistor of the fuser unit detected some temperature error in the hardware.	2-42
0206	---		050B	When the temperature of the center thermistor of the fuser unit is lower than the idle temperature, the side thermistor of the fuser unit detected a temperature higher than the specified value.	2-42
0207	---				
0208	---				
0209	---				
0300	The Lock signal of the polygon motor of the laser unit cannot be detected.	2-40			
0305	---				
0401	BD sensor 1 damaged.	2-40			
0402	BD sensor 4 damaged.	2-40			
0405	---				
0501	The center thermistor of the fuser unit does not reach the specified temperature within the specified time.	2-41			

Error Codes	Description	Refer to:	Error Codes	Description	Refer to:
050C	When the temperature of the center thermistor of the fuser unit is higher than the idle temperature, the side thermistor of the fuser unit detected a temperature lower than the specified value.	2-42	1004	The registration mark sensor L is dirty and cannot normally receive reflected light.	2-45
			1100	---	
			1200	---	
050D	---		1300	---	
050F	---		1400	Condensation occurred in the machine.	2-46
0600	---				
0700	---		1500	Error occurred in the paper eject origin sensor.	2-46
0800	Error occurred in the internal temperature sensor.	2-43	1C00	The reading signal of the EEPROM of the laser unit cannot be detected.	2-46
0900	Machine detected more than 100 times that supplied power was unstable.	2-43	1D01	---	
0A01	The blower failure was detected.	2-43	1D02	---	
0A02	The fuser fan failure was detected.	2-44	1D03	---	
			1D04	---	
0B01	Error occurred in the high-voltage power supply PCB ASSY while the machine is in operation.	2-44	1E01	---	
			1E02	---	
			2001	---	
0B02	Error occurred in the high-voltage power supply PCB ASSY in the ready state.	2-44	2002	---	
			2003	---	
			2004	---	
0C00	Error occurred in the density sensor.	2-44	2005	---	
			2006	---	
0D01	---		2101	---	
0D02	---		2102	---	
0D03	---		2103	---	
0D04	---		2104	---	
0E00	Communication error occurred in the high-voltage power supply PCB ASSY.	2-45	2105	---	
			2201	---	
			2202	---	
1003	The registration mark sensor R is dirty and cannot normally receive reflected light.	2-45	2203	---	
			2204	---	
			2205	---	
			2206	---	
			2207	---	

Error Codes	Description	Refer to:	Error Codes	Description	Refer to:
2301	---		2A03	---	
2302	---		2B01	---	
2401	---		2B02	---	
2402	---		2C01	---	
2403	---		2C02	---	
2404	---		2D01	---	
2405	---		2E01	---	
2408	---		2E02	---	
2409	---		2E03	---	
2501	---		2E04	---	
2502	---		2E05	---	
2503	---		2E06	---	
2504	---		2E07	---	
2601	---		2E08	---	
2602	---		2E0A	---	
2603	---		2F01	---	
2604	---		2F02	---	
2605	---		2F03	---	
2701	---		2F04	---	
2702	---		2F05	---	
2703	---		2F06	---	
2801	---		2F07	---	
2802	---		2F08	---	
2803	---		2F0A	---	
2804	---		3001	---	
2805	---		3002	---	
2806	---		3003	---	
2901	---		3102	---	
2902	---		3202	---	
2903	---		3301	---	
2904	---		3302	---	
2905	---		3401	---	
2906	---		3402	---	
2A01	---		3501	---	
2A02	---		3601	---	

Error Codes	Description	Refer to:	Error Codes	Description	Refer to:
3701	---		4600	Number of pages printed with the laser unit has reached the upper limit.	2-48
3702	---				
3703	---				
3801	Temperature error occurred in the external temperature/humidity sensor.	2-47	4700	The waste toner sensor detected that the waste toner box is almost full.	2-49
3802	Humidity error occurred in the external temperature/humidity sensor.	2-47	4800	After the waste toner sensor detected that the waste toner box was almost full, pages more than the specified number have been printed.	2-49
3900	---				
3A00	Error occurred in the communication between the controller in the main PCB and engine.	2-47	4900	---	
			4A00	---	
4000	Number of the drum unit rotations reaches the upper limit soon.	2-47	4B01	Dot counter of the toner cartridge (Black) or develop roller counter reaches the upper limit soon.	2-49
4001	---		4B02	Dot counter of the toner cartridge (Yellow) or develop roller counter reaches the upper limit soon.	2-49
4002	---				
4003	---		4B03	Dot counter of the toner cartridge (Magenta) or develop roller counter reaches the upper limit soon.	2-49
4004	---				
4200	Number of the drum unit rotations has reached the upper limit.	2-47	4B04	Dot counter of the toner cartridge (Cyan) or develop roller counter reaches the upper limit soon.	2-49
4201	---				
4202	---		4C01	Dot counter of the toner cartridge (Black) or develop roller counter has reached the upper limit was detected.	2-50
4203	---				
4204	---				
4208	---		4C02	Dot counter of the toner cartridge (Yellow) or develop roller counter has reached the upper limit was detected.	2-50
4300	Number of pages printed with the belt unit will reach the upper limit soon. (90%)	2-48	4C03	Dot counter of the toner cartridge (Magenta) or develop roller counter has reached the upper limit was detected.	2-50
4400	Number of pages printed with the belt unit has reached the upper limit.	2-48	4C04	Dot counter of the toner cartridge (Cyan) or develop roller counter has reached the upper limit was detected.	2-50
4408	---				
4500	Number of used pages for the fuser unit has reached the upper limit.	2-48			

Error Codes	Description	Refer to:	Error Codes	Description	Refer to:
4C05	During printing, dot counter of color toner cartridge or develop roller counter has reached the upper limit was detected.	2-50	5902	---	
			5A02	---	
			5B02	---	
4D01	---		5C02	---	
4E01	---		6001	The front cover sensor detected that the front cover was open.	2-53
4F01	The new toner sensor of the toner cartridge (Black) could not detect a new cartridge properly.	2-51	6002	---	
			6003	---	
4F02	The new toner sensor of the toner cartridge (Yellow) could not detect a new cartridge properly.	2-51	6004	The eject sensor detected that the fuser cover was open.	2-53
			6007	---	
4F03	The new toner sensor of the toner cartridge (Magenta) could not detect a new cartridge properly.	2-51	6101	The toner sensor detected that no toner cartridge (Black) was set.	2-54
4F04	The new toner sensor of the toner cartridge (Cyan) could not detect a new cartridge properly.	2-51	6102	The toner sensor detected that no toner cartridge (Yellow) was set.	2-54
5001	Number of used pages for the PF kit MP has reached the upper limit.	2-52	6103	The toner sensor detected that no toner cartridge (Magenta) was set.	2-54
5002	Number of used pages for the PF kit 1 has reached the upper limit.	2-52	6104	The toner sensor detected that no toner cartridge (Cyan) was set.	2-54
5003	Number of used pages for the PF kit 2 has reached the upper limit.	2-52	6200	The current value between the CHG and GRID terminals and the toner sensor detected that there were no toner cartridges of any colors and detected that the drum unit was not set.	2-54
5004	---				
5005	---				
5100	---				
5200	---				
5301	---		6201	---	
5302	---		6202	---	
5401	---		6203	---	
5402	---		6204	---	
5406	---		6208	---	
5502	---		6209	---	
5602	---		620A	---	
5702	---		6300	The waste toner sensor detected that no waste toner box was set.	2-56
5801	---				
5802	---				

Error Codes	Description	Refer to:	Error Codes	Description	Refer to:
6400	The registration mark sensor detected that no belt unit was set.	2-56	6E00	The develop release sensor detected the developer roller disengagement or engagement failure.	2-59
6602	---		6F00	Machine detected that supplied power was unstable. (Less than 100 times)	2-59
6701	---				
6801	The internal temperature sensor or side thermistor of the fuser unit detected a temperature higher than the specified value.	2-57	7000	After the registration rear sensor detects paper pass, the eject sensor does not detect paper pass.	2-59
6802	---				
6901	Some fuser unit errors occurred at power-ON or upon recovery from sleep mode.	2-57	7001	---	
			7002	---	
			7003	---	
6902	After the errors was detected at the fuser unit, power was turned ON again and the error is being checked. (If power is turned OFF and ON after error code 6901 occurred, this code is displayed for about 15 minutes.)	2-57	7004	---	
			7100	After the registration rear sensor detects the end of paper pass and the specified period of time has passed, the eject sensor continues to detect paper pass.	2-60
6A00	Electric discharge that may be caused by dirt on the corona wire of the drum unit was detected.	2-58	7101	---	
			7102	---	
			7103	---	
6B01	Electric discharge was detected when the number of the drum unit rotations had become more than twice of the upper limit.	2-58	7104	---	
			7105	---	
			7106	---	
6B02	---		7200	When the paper is fed from the MP tray, after the MP registration front sensor detects paper pass, the registration rear sensor does not detect paper pass after a set period of time.	2-61
6B03	---				
6B04	---				
6B0A	---				
6C01	---				
6C02	After the T2 paper tray unit is opened and closed or the power is turned ON, the T2 plate origin sensor detects that lift-up of the plate of the T2 paper tray unit is not completed within the specified period of time.	2-58	7300	In the case of printing by feeding paper from the paper tray 1, after the T1 paper feed sensor detects paper pass, the registration front sensor does not detect paper pass after a set period of time.	2-62
6C03	---		7301	---	
6C04	---				
6D00	---				

Error Codes	Description	Refer to:	Error Codes	Description	Refer to:
7400	In the case of printing by feeding paper from the T2 paper tray unit, after the T2 paper feed sensor detects paper pass, the registration front sensor does not detect paper pass after a set period of time.	2-62	8505	The T1 paper feed sensor detected that the paper tray 1 is open in 2-sided printing or printing by feeding paper from the T2 paper tray unit. (after the registration of printing in the engine)	2-64
7401	---		8506	---	
7501	---		8507	---	
7502	---		8508	---	
7601	---		8601	---	
7602	---		8602	---	
7700	After the first side is printed in 2-sided printing mode, the registration front sensor does not detect paper pass after a set period of time.	2-63	8603	---	
			8604	---	
			8701	---	
			8702	---	
7701	---		8703	---	
7702	---		8801	---	
7703	---		8802	---	
7704	---		8901	---	
7705	---		8902	---	
7801	---		8903	The back cover sensor detected the open state when 2-sided printing is started. (before the registration of printing in the engine)	2-64
7802	---				
7900	---				
7C00	---				
7D00	---		8904	The back cover sensor detected the open state during 2-sided printing. (after the registration of printing in the engine)	2-64
7E00	---				
8000	---				
8401	---		8A01	The registration rear sensor detected that the fed paper was larger or smaller than the specified size in 2-sided printing.	2-65
8402	While the T2 paper tray unit is open state, print or adjustment operation was attempted.	2-63	8A02	The registration rear sensor detected that the length of the paper is too long and it may hit within the machine in 2-sided printing.	2-65
8501	The T1 paper feed sensor detected that the paper tray 1 is open in 2-sided printing or printing by feeding paper from the T2 paper tray unit. (before the registration of printing in the engine)	2-64	8C00	---	
8502	---		8D01	The registration rear sensor detected that the paper loaded in the paper tray was smaller than the specified size.	2-65
8503	---				
8504	---				

Error Codes	Description	Refer to:	Error Codes	Description	Refer to:
8D02	The paper size which is not supported by the output tray is set for printing from the printer driver.	2-66	9303	When paper was fed from the T2 paper tray unit, the T2 paper feed sensor detected that no paper was in the T2 paper tray unit.	2-69
8E01	---				
8E02	Upon fax reception, the paper size setting is the one other than A4, Letter, Legal, and Folio.	2-66	9304	---	
			9305	---	
8E03	---		9306	For printing specifying Auto, it was detected that no paper was loaded in any of the paper trays.	2-69
8F01	---				
8F02	---		9307	Upon receiving a fax or printing a list or report, the machine detected that paper tray empty of paper.	2-70
8F03	---				
9001	The size of paper loaded in the MP tray and the one specified from the driver are not same when paper is fed from the MP tray.	2-67	9401	---	
			9402	---	
			9403	---	
9002	The size of paper loaded in the paper tray 1 and the one specified from the driver are not same when paper is fed from the paper tray 1.	2-67	9404	---	
			9501	---	
			9502	---	
			9503	---	
9003	The size of paper loaded in the T2 paper tray unit and the one specified from the driver are not same when paper is fed from the T2 paper tray unit.	2-67	9504	---	
			9505	---	
			9601	---	
			9608	---	
9004	---		9701	For 2-sided printing, the tray whose paper size was not supported by 2-sided printing was selected.	2-71
9005	---				
9102	---				
9103	---		9702	For printing by feeding paper from the paper tray 1, the size of paper specified from the driver set the size which was not supported by the paper tray 1.	2-71
9104	---				
9105	---				
9200	---				
9301	When paper was fed from the MP tray, the MP paper empty sensor detected that no paper was in the MP tray.	2-68	9703	For printing by feeding paper from the T2 paper tray unit, the size of paper specified from the driver set the size which was not supported by the T2 paper tray unit.	2-71
9302	When paper was fed from the paper tray 1, the T1 paper feed sensor detected that no paper was in the paper tray 1.	2-68			
			9704	---	
			9705	---	

Error Codes	Description	Refer to:	Error Codes	Description	Refer to:
9801	Error occurred with the value measured during color density adjustment performed from the control panel.	2-72	A200	During document scanning, the first side document scanning position sensor detected that the document length was 90 cm or more.	2-76
9802	Dot counter or develop roller counter of color toner has reached the upper limit during color density adjustment performed from the control panel.	2-72	A300	Though a document was fed and conveyed by the specified distance or longer, the first side document scanning position sensor did not detect the passing of the paper.	2-76
9803	Density patch measurement ended unsuccessfully during color density adjustment performed from the control panel.	2-73	A400	The ADF cover sensor detected that the ADF cover was opened.	2-77
9804	Error occurred with the value measured during density sensor sensitivity calibration.	2-73	A500	Upon scanning a fax, the first side CIS white or black calibration data was not within the normal range.	2-77
9901	---		A600	Though a fax was scanned again after A500 error, the first side CIS white or black calibration data was not within the normal range.	2-77
9902	---		A700	The ROM color parameter does not match the first side CIS or second side CIS.	2-78
9903	---		A800	---	
9A01	Error occurred with the value measured during auto color registration performed from the control panel.	2-74	A900	When an image was scanned and processed, a scanning error occurred.	2-78
9A02	Dot counter or develop roller counter of color toner has reached the upper limit during auto color registration performed from the control panel.	2-74	AA00	---	
9A03	Error occurred during patch data printing in auto color registration performed from the control panel.	2-75	AB00	---	
9C01	---		AC00	Upon scanning a fax, the second side white or black calibration data was not within the normal range.	2-78
9C02	---		AD00	First side scanned data cannot be output with the required number of pixels, and image processing cannot be completed successfully.	2-79
9C03	---		AF00	The first side CIS fails to move, remaining at the home position.	2-79
9C06	---				
9C07	---				
A000	Upon scanning the second side in duplex scanning, scanned data cannot be output with the required number of pixels and image processing is not completed successfully.	2-75			

Error Codes	Description	Refer to:	Error Codes	Description	Refer to:
B000	The first or second side CIS flat cable was detected to be not inserted correctly.	2-80	C004	The current time necessary for user authentication is unavailable due to time not being obtained.	2-82
B300	---		C700	The memory is insufficient to expand the data of PC-Print.	2-83
B400	---				
B700	---				
B800	---				
B900	---				
BA00	---				
BB00	The white level value obtained with function code 55 was outside the specified range.	2-80	C800	The memory used to store secure print data exceeded the memory size for secure print data.	2-83
BC00	Though a fax was scanned again after AC00 error, the second side white or black calibration data was not within the normal range.	2-81	CA00	---	
			D100	An error occurred during modem initialization.	2-83
			D200	The machine detected that the modem PCB was disconnected.	2-83
BD00	The black level value obtained with function code 55 was outside the specified range.	2-81	D800	Error occurred during touch panel initialization.	2-84
			D900	Communication between the panel PCB and main PCB is unavailable during touch panel initialization.	2-84
BE00	---		DA00	After the initialization of the panel PCB, no response was sent from the panel PCB for a period of time.	2-84
BF00	The first side document scanning position sensor detected that the document was 400 mm or more in length and could not be fed from the ADF in duplex feeding.	2-81	DB00	USB communication between the main PCB and panel PCB is unavailable.	2-84
C001	Timeout occurred with access request sent to server due to incorrect server address, network disconnection, or inactive server.	2-82	E000	Some ROM checksum error occurred.	2-85
			E100	Program error.	2-85
			E400	The failed DIMM is installed, or the DIMM is not installed correctly.	2-85
C002	User authentication is unavailable due to incorrect user name, incorrect password, or asynchronous date and time between the machine and server.	2-82	E500	Error occurred when DRAM on the main PCB ASSY was accessed.	2-85
C003	Access to a file is unavailable due to incorrect directory name, no write permission on directory, file write lock, or no write permission on file.	2-82	E600	Error occurred during writing to EEPROM on the main PCB ASSY.	2-85

Error Codes	Description	Refer to:
E701	Operation failure of the file system of the flash ROM on the main PCB.	2-85
E702	Error occurred during reading from the flash ROM on the main PCB.	2-85
E900	NFC PCB initialization failed.	2-86
EC00	Overcurrent was caused because a USB device that did not meet the specifications was inserted into the USB port.	2-86
F900	Setting by spec code is not entered.	2-86
FA01	---	
FA02	---	
FA03	---	
FB01	---	
FB02	---	
FB03	---	
FB04	---	
FB05	---	
FB06	---	
FB07	---	
FB08	---	
FB09	---	
FB0A	---	
FB0B	---	
FB0C	---	
FB0D	---	
FB0F	---	
FC01	---	
FC02	---	
FC03	---	
FC04	---	
FC05	---	

3.2 Error Message

The error messages displayed on the LCD of the machine and their description are shown in the table below.

Error Message		State	Error Codes	Refer to:
Upper line	Middle line			
Access Denied	Function Locked.	In the case of PC-print, authentication of print restricted ID failed.	---	4.14.1
	Function Locked. Job Deleted. Press Stop[X].		---	4.14.1
Access Error	Press Stop[X].Put the device back in and try again.	The device was removed during data was being processed.	---	4.14.2
Calibration	Calibration failed. Insufficient Toner for Calibration.	Dot counter or develop roller counter of color toner has reached the upper limit during color density adjustment performed from the control panel.	9802	2-72
	Calibration failed. Press [Retry], and try again.	Density patch measurement ended unsuccessfully during color density adjustment performed from the control panel.	9803	2-73
		Error occurred with the value measured during density sensor sensitivity calibration.	9804	2-73
	Calibration failed. Turn the power off and then back on again.	Error occurred with the value measured during color density adjustment performed from the control panel.	9801	2-72
Cartridge Error	Put the Toner Cartridge back in.	The new toner sensor of the toner cartridge (Black) could not detect a new cartridge properly.	4F01	2-51
	Put the Cyan #C Toner Cartridge back in.	The new toner sensor of the toner cartridge (Cyan) could not detect a new cartridge properly.	4F04	2-51
	Put the Magenta #C Toner Cartridge back in.	The new toner sensor of the toner cartridge (Magenta) could not detect a new cartridge properly.	4F03	2-51
	Put the Yellow #C Toner Cartridge back in.	The new toner sensor of the toner cartridge (Yellow) could not detect a new cartridge properly.	4F02	2-51
Condensation	Leave switched ON. Fully open the Front Cover. Wait 30 minutes, switch OFF and close cover, then switch ON.	Condensation occurred in the machine.	1400	2-46

Error Message		State	Error Codes	Refer to:
Upper line	Middle line			
Cooling Down	Wait for a while	The internal temperature sensor or side thermistor of the fuser unit detected a temperature higher than the specified value.	6801	2-57
Cover is Open	Close the ADF Cover.	The ADF cover sensor detected that the ADF cover is open in the ready state.	A400	2-77
	Close the ADF Cover, then press Stop[X].	The ADF cover sensor detected that the ADF cover is open during scanning.		
	Close the Back Cover of the machine.	The eject sensor detected that the fuser cover was open.	6004	2-53
	Close the Front Cover.	The front cover sensor detected that the front cover was open.	6001	2-53
Document Jam	Clear the scanner jam, then press the Stop Key.	During document scanning, the first side document scanning position sensor detected that the document length was 90 cm or more.	A200	2-76
		First side document scanning position sensor did not detect paper pass.	A300	2-76
Drum !	Slide the Blue tab on Drum Unit.	Electric discharge that may be caused by dirt on the corona wire of the drum unit was detected.	6A00	2-58
Drum Stop	Replace the Drum Unit.	Electric discharge was detected when the number of the drum unit rotations had become more than twice of the upper limit.	6B01	2-58
Ignore Data	-	Undecodable data is found during printing.	---	4.14.1
	Press Stop Key	Undecodable PS data is received.	---	4.14.1
Jam 2-sided	Pull the paper tray completely out of the machine. Check inside the machine towards the rear. Or open the Back Cover to remove the jammed paper.	After the first side is printed in 2-sided printing mode, the registration front sensor does not detect paper pass after a set period of time.	7700	2-63

Error Message		State	Error Codes	Refer to:
Upper line	Middle line			
Jam Inside	Open the Front Cover, pull out all four drum and toner cartridge assemblies and remove the jammed paper.	After the registration rear sensor detects paper pass, the eject sensor does not detect paper pass.	7000	2-59
Jam MP Tray	Remove the jammed paper from MP Tray and press [Retry].	When the paper is fed from the MP tray, after the MP registration front sensor detects paper pass, the registration rear sensor does not detect paper pass after a set period of time.	7200	2-61
Jam Rear	Open the Back Cover and remove the jammed paper, then press [Start].	After the registration rear sensor detects the end of paper pass and the specified period of time has passed, the eject sensor continues to detect paper pass.	7100	2-60
Jam Tray 1	Pull the paper tray1 completely out of the machine and remove the jammed paper.	In the case of printing by feeding paper from the paper tray 1, after the T1 paper feed sensor detects paper pass, the registration front sensor does not detect paper pass after a set period of time.	7300	2-62
Jam Tray 2	Pull the paper tray2 completely out of the machine and remove the jammed paper.	In the case of printing by feeding paper from the T2 paper tray unit, after the T2 paper feed sensor detects paper pass, the registration front sensor does not detect paper pass after a set period of time.	7400	2-62

Error Message		State	Error Codes	Refer to:
Upper line	Middle line			
Log Access Error	Authentication error, contact your administrator.	User authentication is unavailable due to incorrect user name, incorrect password, or asynchronous date and time between the machine and server.	C002	2-82
		Access to a file is unavailable due to incorrect directory name, no write permission on directory, file write lock, or no write permission on file.	C003	2-82
	Server timeout, contact your administrator.	Timeout occurred with access request sent to server due to incorrect server address, network disconnection, or inactive server.	C001	2-82
	Wrong Date & Time, contact your administrator.	The current time necessary for user authentication is unavailable due to time not being obtained.	C004	2-82
Machine Error **	---	Some kind of machine error occurred. Refer to the error code of "***".	**	
Maintenance	Replace Fuser	Number of used pages for the fuser unit has reached the upper limit.	4500	2-48
	Replace Laser	Number of pages printed with the laser unit has reached the upper limit.	4600	2-48
	Replace PF Kit 1	Number of used pages for the PF kit 1 has reached the upper limit.	5002	2-52
	Replace PF Kit 2	Number of used pages for the PF kit 2 has reached the upper limit.	5003	2-52
	Replace PF Kit MP	Number of used pages for the PF kit MP has reached the upper limit.	5001	2-52
No Belt Unit	Open the Front Cover, pull out all Drum Units completely and install the Belt Unit.	The registration mark sensor detected that no belt unit was set.	6400	2-56
No Drum Unit	Install the Drum Unit.	The current value between the CHG and GRID terminals and the toner sensor detected that there were no toner cartridges of any colors and detected that the drum unit was not set.	6200	2-54

Error Message		State	Error Codes	Refer to:
Upper line	Middle line			
No HUB Support	-	USB HOST HUB connection error	---	4.14.2
No Paper	Reload paper in MP Tray.	When paper was fed from the MP tray, the MP paper empty sensor detected that no paper was in the MP tray.	9301	2-68
	Reload paper in Tray.	For printing specifying Auto, it was detected that no paper was loaded in any of the paper trays.	9306 9307	2-69 2-70
	Reload paper in Tray1.	When paper was fed from the paper tray 1, the T1 paper feed sensor detected that no paper was in the paper tray 1.	9302	2-68
	Reload paper in Tray 2.	When paper was fed from the T2 paper tray unit, the T2 paper feed sensor detected that no paper was in the T2 paper tray unit.	9303	2-69
No Permission	Function Locked	In the case of PC-print, the ID which does not have permission to perform color printing was used.	---	4.10.3
	Function Locked. Job Deleted. Press Stop[X].	In the case of Secure print or USB Direct print, the ID which does not have permission to perform color printing was used.	---	4.10.3
No Toner	Open the Front Cover, then install Toner Cartridge. Black (BK).	The toner sensor detected that no toner cartridge (Black) was set.	6101	2-54
	Open the Front Cover, then install Toner Cartridge. Cyan (C).	The toner sensor detected that no toner cartridge (Cyan) was set.	6104	2-54
	Open the Front Cover, then install Toner Cartridge. Magenta (M).	The toner sensor detected that no toner cartridge (Magenta) was set.	6103	2-54
	Open the Front Cover, then install Toner Cartridge. Yellow (Y).	The toner sensor detected that no toner cartridge (Yellow) was set.	6102	2-54

Error Message		State	Error Codes	Refer to:
Upper line	Middle line			
No Tray	The paper tray cannot be detected, re-install Tray2.	While the T2 paper tray unit is open state, print or adjustment operation was attempted.	8402	2-63
	The paper tray cannot be detected, re-install Tray1.	The T1 paper feed sensor detected that the paper tray 1 is open in 2-sided printing or printing by feeding paper from the T2 paper tray unit. (after the registration of printing in the engine)	8505	2-64
		The T1 paper feed sensor detected that the paper tray 1 is open in 2-sided printing or printing by feeding paper from the T2 paper tray unit. (before the registration of printing in the engine)	8501	2-64
No Waste Toner	Install the Waste Toner Box.	The waste toner sensor detected that no waste toner box was set.	6300	2-56
Out of Memory	Press Stop Key	The memory is insufficient to expand the data of PC-Print.	C700	2-83
Out of Fax Memory	Delete unwanted fax data.	The memory becomes full when Fax preview is ON.	---	4.10.2
	Print fax data from All Settings>Fax >Print fax	The memory becomes full when Fax preview is OFF and memory reception is ON.	---	4.10.2
Print Data Full	Print Data is full. Press Stop[X] Key and delete the previously stored data.	The memory used to store secure print data exceeded the memory size for secure print data.	C800	2-83
Print Unable **	Turn the power off and then back on again.	Error related to print Refer to the error code of "***".	**	

Error Message		State	Error Codes	Refer to:
Upper line	Middle line			
Registration	Registration failed. Insufficient Toner for Registration.	Dot counter or develop roller counter of color toner has reached the upper limit during auto color registration performed from the control panel.	9A02	2-74
	Registration failed. Press [Retry], and try again.	Error occurred during patch data printing in auto color registration performed from the control panel.	9A03	2-75
	Registration failed. Turn the power off and then back on again.	Error occurred with the value measured during auto color registration performed from the control panel.	9A01	2-74
Replace Toner	Open the Top Cover, replace Toner Cartridge.	Dot counter of the toner cartridge (Black) or develop roller counter has reached the upper limit was detected.	4C01	2-50
		Dot counter of the toner cartridge (Cyan) or develop roller counter has reached the upper limit was detected.	4C04	2-50
		During printing, dot counter of color toner cartridge or develop roller counter has reached the upper limit was detected.	4C05	2-50
		Dot counter of the toner cartridge (Magenta) or develop roller counter has reached the upper limit was detected.	4C03	2-50
		Dot counter of the toner cartridge (Yellow) or develop roller counter has reached the upper limit was detected.	4C02	2-50
Replace WT Box	Replace the Waste Toner Box inside the machine.	After the waste toner sensor detected that the waste toner box was almost full, pages more than the specified number have been printed.	4800	2-49
Scan Unable **	-	Error related to scanning Refer to the error code of “**”.	**	

Error Message		State	Error Codes	Refer to:
Upper line	Middle line			
Scanner Error	-	The white level value obtained with function code 55 was outside the specified range.	BB00	2-80
	-	The black level value obtained with function code 55 was outside the specified range.	BD00	2-81
Self-Diagnostic	Turn the power off, then on again. Leave the machine for 15 min.	Some fuser unit errors occurred at power-ON or upon recovery from sleep mode.	6901	2-57
	Will Automatically Restart within 15 minutes.	After the errors was detected at the fuser unit, power was turned ON again and the error is being checked. (If power is turned OFF and ON after error code 6901 occurred, this code is displayed for about 15 minutes.)	6902	2-57
Short paper	Open the Back Cover and then press [Retry].	The registration rear sensor detected that the paper loaded in the paper tray was smaller than the specified size.	8D01	2-65
Size Error	Specify the correct paper size for Tray 1.	For printing by feeding paper from the paper tray 1, the size of paper specified from the driver set the size which was not supported by the paper tray 1.	9702	2-71
	Specify the correct paper size for Tray 2.	For printing by feeding paper from the T2 paper tray unit, the size of paper specified from the driver set the size which was not supported by the T2 paper tray unit.	9703	2-71
Size Error 2-sided	Press [OK]. Specify the correct paper and load the same size paper as the Printer driver setting.	For 2-sided printing, the tray whose paper size was not supported by 2-sided printing was selected.	9701	2-71
	Specify the correct paper.	The registration rear sensor detected that the fed paper was larger or smaller than the specified size in 2-sided printing.	8A01	2-65

Error Message		State	Error Codes	Refer to:
Upper line	Middle line			
Size mismatch	Reload correct paper in Tray1, then press [Retry].	The size of paper loaded in the paper tray 1 and the one specified from the driver are not same when paper is fed from the paper tray 1.	9002	2-67
	Reload correct paper in Tray2, then press [Retry].	The size of paper loaded in the T2 paper tray unit and the one specified from the driver are not same when paper is fed from the T2 paper tray unit.	9003	2-67
	Reload correct paper in MP Tray, then press [Retry].	The size of paper loaded in the MP tray and the one specified from the driver are not same when paper is fed from the MP tray.	9001	2-67
Size Mismatch	Reload correct paper.	Upon fax reception, the paper size setting is the one other than A4, Letter, Legal, and Folio.	8E02	2-66
Small paper	Open the Back Cover and then press [Retry].	The paper size which is not supported by the output tray is set for printing from the printer driver.	8D02	2-66

Error Message		State	Error Codes	Refer to:
Upper line	Middle line			
Supplies	Belt End Soon	Number of pages printed with the belt unit will reach the upper limit soon.	4300	2-48
	Drum End Soon.	Number of the drum unit rotations reaches the upper limit soon.	4000	2-47
	Replace Belt	Number of pages printed with the belt unit has reached the upper limit.	4400	2-48
	Replace Drum	Number of the drum unit rotations has reached the upper limit.	4200	2-47
	Toner Low	Dot counter of the toner cartridge (Black) or develop roller counter reaches the upper limit soon.	4B01	2-49
		Dot counter of the toner cartridge (Cyan) or develop roller counter reaches the upper limit soon.	4B04	2-49
		Dot counter of the toner cartridge (Magenta) or develop roller counter reaches the upper limit soon.	4B03	2-49
		Dot counter of the toner cartridge (Yellow) or develop roller counter reaches the upper limit soon.	4B02	2-49
WT Box End Soon	The waste toner sensor detected that the waste toner box is almost full.	4700	2-49	
Toner Error	One or more Toner Cartridges are not detected. Pull out and reinsert all 4 Toner Cartridges.	The develop release sensor detected the developer roller disengagement or engagement failure.	6E00	2-59
Touchscreen initialization failed	Remove any material which is on the touchscreen.	Error occurred during touch panel initialization.	D800	2-84
Tray 2 Error	Take out Tray 2 and push it back in firmly.	After the T2 paper tray unit is opened and closed or the power is turned ON, the T2 plate origin sensor detects that lift-up of the plate of the T2 paper tray unit is not completed within the specified period of time.	6C02	2-58
Unable to Update	Check the firmware update file and try again.	Execution of the program update cannot be started because other function is being executed.	---	4.14.3

Error Message		State	Error Codes	Refer to:
Upper line	Middle line			
Unusable Device	-	An USB device that did not meet the specifications was inserted into the USB port.	---	4.14.2
	Remove the Device. Turn the power off and back on again.	Overcurrent was caused because a USB device that did not meet the specifications was inserted into the USB port.	EC00	2-86
2-sided Disabled	Close the Back Cover of the Machine.	The back cover sensor detected the open state when 2-sided printing is started. (before the registration of printing in the engine)	8903	2-64
		The back cover sensor detected the open state during 2-sided printing. (after the registration of printing in the engine)	8904	2-64
	Reload paper, then press Start.	The registration rear sensor detected that the length of the paper is too long and it may hit within the machine in 2-sided printing.	8A02	2-65

3.3 Communications Error Code

Code 1	Code 2	Cause	Refer to:
10	07	No document loaded at the time of outgoing call for document transmission.	4.11.1
10	08	Wrong FAX number called.	4.13.1
11	01	No dial tone detected before start of dialing.	4.13.1
11	02	Busy tone detected before dialing.	4.13.1
11	03	2nd dial tone not detected.	4.13.1
11	05	No loop current detected.	4.13.1
11	06	Busy tone detected after dialing or called.	4.13.1
11	07	No response from the remote terminal in calling.	4.13.1
11	10	Tone not detected after dialing.	4.13.1
11	11	No response signal after transmission of Fax2 net command.	4.13.1
13	12	Error signal received after transmission of Fax2 net command.	4.13.1
16	09	No cipher registered.	4.13.1
17	01	Outgoing call with a number unable to be used in NGN line. (Equal to or more than 33 digits, or nonnumeric characters)	4.13.2
17	07	No response from the remote terminal in receiving.	4.13.2
1C	01	Lack of access right detected in NGN line. (T38: 403 Forbidden)	4.13.4
1C	02	File or folder (directory) not found in NGN line. (T38: 404 Not Found)	4.13.4
1C	03	Context-sensitive acceptance impossible in NGN line. (T38: 488 Not Acceptable Here)	4.13.4
1C	04	SIP (Session Initiation Protocol) connection not allowed. (T38) Outgoing call with OFF selected in USW NGN fax setting or before acquisition of SIP information.	4.13.4
1C	05	Net internal error detected. (T38)	4.13.4
1C	06	SIP server timeout. (T38)	4.13.4
1C	08	Error other than 1C01, 1C02, 1C03, 1C04, 1C06, 1D01, 1D02, and 1D04 detected.	4.13.4
1D	01	State of being busy detected in NGN line. (T38: 486 Busy)	4.13.4
1D	02	State of being temporarily unavailable detected in NGN line. (T38: 480 Temporarily Unavailable)	4.13.4
1D	04	Network cable not connected (upon detecting link down) or state of not being connected to the network. (T38)	4.13.4
20	01	Flag field not detected.	4.13.4

Code 1	Code 2	Cause	Refer to:
20	02	Carrier was OFF for 200 ms or longer.	4.13.4
20	03	Abort detected ("1" in succession for 7 bits or more).	4.13.4
20	04	Overrun detected.	4.13.4
20	05	A frame for 3 seconds or more received.	4.13.4
20	06	CRC error in answerback.	4.13.4
20	07	Echo command received.	4.13.4
20	08	Invalid command received.	4.13.4
20	09	Command ignored once for document setting or for dumping-out at turn-around transmission.	4.13.4
20	0A	T5 time-out error	4.13.4
20	0B	CRP received.	4.13.4
20	0C	EOR and NULL received.	4.13.4
20	0D	Though the FIF command transmission bit is ON, the corresponding command has not been received.	4.13.4
20	0E	EOR command received.	4.13.4
20	13	After the last page was received, connection was broken without receiving DCN. (After EOP reception and CFR transmission, BYE notification was received before DCN reception.) (T38)	4.13.4
32	01	Remote terminal only with V.29 capability in 2,400 or 4,800 bps transmission.	4.13.4
32	02	Remote terminal not ready for polling.	4.13.4
32	10	Remote terminal not equipped with password function or its password switch OFF.	4.13.4
32	11	Remote terminal not equipped with or not ready for confidential mailbox function.	4.13.4
32	12	Remote terminal not equipped with or not ready for relay broadcasting function.	4.13.4
32	13	No confidential mail in the remote terminal.	4.13.4
32	14	The available memory space of the remote terminal is less than that required for reception of the confidential mail or relay broad-casting instruction.	4.13.4
32	15	Machine at the other end does not have cipher receiving function.	4.13.4
32	16	Machine at the other end does not have SEP function.	4.13.4
32	17	Machine at the other end does not have SUB function.	4.13.4
32	18	Remote terminal not equipped with color function.	4.13.4
40	02	Illegal coding system requested.	4.13.4
40	03	Illegal paper width requested.	4.13.4
40	05	ECM requested although not allowed.	4.13.4

Code 1	Code 2	Cause	Refer to:
40	06	Polled while not ready.	4.13.4
40	07	No document to send when polled.	4.11.1
40	10	Nation code or manufacturer code not correct.	4.13.1
40	11	Group number not registered in relay broadcasting was selected or the total of broadcast destinations exceeded the allowed maximum destinations.	4.13.1
40	12	Retrieval was done though the machine had not been waiting for retrieval.	4.13.1
40	13	Polled by any other manufacturers' terminal while waiting for secure polling.	4.13.1
40	14	No common key is registered when a common key is used.	4.13.1
40	15	Instructions for red and black color reception while red and black reception disabled.	4.13.4
40	16	Instructions for cipher communications while cipher reception disabled.	4.13.4
40	17	Invalid resolution selected.	4.13.4
40	20	Invalid full color mode selected.	4.13.4
50	01	Vertical resolution capability changed after calibration of background color.	4.13.4
63	01	Password plus "lower 4 digits of telephone number" not coincident.	4.13.1
63	02	Password not correct.	4.13.1
63	03	Polling ID not correct.	4.13.1
63	04	Provided confidential ID and mailbox ID are different.	4.13.1
63	05	Relay broadcasting ID inconsistency	4.13.1
63	06	Provided retrieval ID and mailbox retrieval ID are different.	4.13.1
63	07	Select reception ID inconsistency	4.13.2
63	08	Cipher Key inconsistency	4.13.2
74	xx	DCN received.	4.13.4
80	01	Fallback impossible.	4.13.4
90	01	Unable to detect video signals or commands within 6 seconds after CFR is transmitted.	4.13.4
90	02	Received PPS containing invalid page count or block count.	4.13.4
A0	03	Error correction sequence not terminated even at the final transmission speed for fallback.	4.13.4
A0	11	Receive buffer empty. (5-second time-out)	4.13.2
A0	12	Receive buffer full during operation except receiving into memory.	4.13.5

Code 1	Code 2	Cause	Refer to:
A0	13	Decoding error continued on 500 lines or more.	4.13.4
A0	14	Decoding error continued for 15 seconds or more.	4.13.4
A0	15	Time-out: 13 seconds or more for one-line transmission.	4.13.4
A0	16	RTC not found or carrier OFF detected for 6 seconds.	4.13.4
A0	17	RTC found but no command detected for 60 seconds or more.	4.13.4
A0	19	No video data to be sent.	4.13.4
A0	20	Color fax continuous reception impossible (Low toner level)	4.13.4
A8	01	RTN, PIN, or ERR received (Sender)	4.13.4
A9	01	RTN, PIN, or ERR received (Recipient)	4.13.4
AA	18	Receive buffer full during receiving into memory.	4.13.5
B0	01	Polarity inversion detection	4.13.2
B0	02	Unable to receive the next-page data.	4.13.2
B0	03	Unable to receive polling even during turn-around transmission due to call reservation.	4.13.2
B0	04	PC interface error	4.13.2
C0	01	No common modulation mode or failed to poll.	4.13.4
C0	02	Unable to detect JM.	4.13.4
C0	03	Unable to detect CM.	4.13.4
C0	04	Unable to detect CJ.	4.13.4
C0	10	Cannot finish V. 34 negotiation or training.	4.13.4
C0	11	Modem error detected during V. 34 negotiation or training.	4.13.4
C0	20	Modem error detected during sending of commands.	4.13.4
C0	21	Modem error detected during receiving of commands.	4.13.4
C0	22	Control channel connection time-out.	4.13.4
C0	30	Modem error detected during sending of video signals.	4.13.4
C0	31	Modem error detected during receiving of video signals.	4.13.4
E0	01	1300 Hz signal detection failure during opposite communication inspection operation.	4.13.4
E0	02	PB signal detection failure during opposite communication inspection operation.	4.13.4
E0	03	Command not detected from RS232C in opposite communication.	4.13.4

4. TROUBLESHOOTING

4.1 Error Cause and Remedy

■ Error code 0100

Print Unable 01
Turn the power off and then back on again.

ASIC error or motor driver error occurred.

Step	Cause	Remedy
1	Main PCB failure	Replace the main PCB ASSY.

■ Error code 0201

Print Unable 02
Turn the power off and then back on again.

Synchronization signal from the main motor cannot be detected. Or the main motor speed is unstable after a set period of time.

Step	Cause	Remedy
1	Connection failure of the main motor harness	Reconnect the main motor harness.
2	Connection failure of the low-voltage power supply PCB harness	Reconnect the low-voltage power supply PCB harness.
3	Part in the process drive unit damaged	Replace the process drive unit.
4	Fuser unit damaged	Replace the fuser unit.
5	Low-voltage power supply PCB failure	Replace the low-voltage power supply PCB unit.
6	Main PCB failure	Replace the main PCB ASSY.

■ Error code 0202

Print Unable 02
Turn the power off and then back on again.

Synchronization signal from the process motor cannot be detected. Or the process motor speed is unstable after a set period of time.

Step	Cause	Remedy
1	Connection failure of the process motor harness	Reconnect the process motor harness.
2	Connection failure of the low-voltage power supply PCB harness	Reconnect the low-voltage power supply PCB harness.
3	Part in the process drive unit damaged	Replace the process drive unit.
4	Low-voltage power supply PCB failure	Replace the low-voltage power supply PCB unit.
5	Main PCB failure	Replace the main PCB ASSY.

■ **Error code 0300**

Print Unable 03
Turn the power off and then back on again.

The Lock signal of the polygon motor of the laser unit cannot be detected.

Error code 0401

Print Unable 04
Turn the power off and then back on again.

BD sensor 1 damaged.

Error code 0402

Print Unable 04
Turn the power off and then back on again.

BD sensor 4 damaged.

Step	Cause	Remedy
1	Connection failure of the polygon motor harness	Reconnect the polygon motor harness.
2	Laser unit failure	Replace the laser unit.
3	Main PCB failure	Replace the main PCB ASSY.

■ **Error code 0501**

Print Unable 05
Turn the power off and then back on again.

The center thermistor of the fuser unit does not reach the specified temperature within the specified time.

Error code 0502

Print Unable 05
Turn the power off and then back on again.

After the temperature of the fuser unit rises to a certain level, the temperature of the center thermistor does not reach the specified temperature within the specified period of time in the next step.

Error code 0503

Print Unable 05
Turn the power off and then back on again.

The center thermistor of the fuser unit detected a temperature higher than the specified value.

Error code 0504

Print Unable 05
Turn the power off and then back on again.

After the center thermistor of the fuser unit was normally heated, it detected a temperature lower than the specified value.

Error code 0505

Print Unable 05
Turn the power off and then back on again.

The center thermistor of the fuser unit detected a temperature rise greater than the specified value within a set period of time.

Error code 0506

Print Unable 05
Turn the power off and then back on again.

The center thermistor of the fuser unit detected a temperature fall greater than the specified value within a set period of time.

< User Check >

- Turn OFF the power switch. After several seconds, turn ON the power again and check that this error is reset.

Step	Cause	Remedy
1	Connection failure of the center or side thermistor harness of the fuser unit	Reconnect the harness of the center thermistor or side thermistor of the fuser unit.
2	Connection failure of the heater harness of the fuser unit	Reconnect the heater harness of the fuser unit.
3	Connection failure of the eject sensor PCB harness	Reconnect the eject sensor PCB harness.
4	Connection failure of the low-voltage power supply PCB harness	Reconnect the low-voltage power supply PCB harness.
5	Eject sensor PCB failure	Replace the eject sensor PCB ASSY.
6	Fuser unit failure	Replace the fuser unit.
7	Low-voltage power supply PCB failure	Replace the low-voltage power supply PCB unit.
8	Main PCB failure	Replace the main PCB ASSY.

■ **Error code 050A**

Print Unable 05
Turn the power off and then back on again.

The center thermistor or side thermistor of the fuser unit detected some temperature error in the hardware.

Error code 050B

Print Unable 05
Turn the power off and then back on again.

When the temperature of the center thermistor of the fuser unit is lower than the idle temperature, the side thermistor of the fuser unit detected a temperature higher than the specified value.

Error code 050C

Print Unable 05
Turn the power off and then back on again.

When the temperature of the center thermistor of the fuser unit is higher than the idle temperature, the side thermistor of the fuser unit detected a temperature lower than the specified value.

< User Check >

- Turn OFF the power switch. After several seconds, turn ON the power again and check that this error is reset.

Step	Cause	Remedy
1	Connection failure of the center or side thermistor harness of the fuser unit	Reconnect the harness of the center thermistor or side thermistor of the fuser unit.
2	Connection failure of the heater harness of the fuser unit	Reconnect the heater harness of the fuser unit.
3	Connection failure of the eject sensor PCB harness	Reconnect the eject sensor PCB harness.
4	Connection failure of the low-voltage power supply PCB harness	Reconnect the low-voltage power supply PCB harness.
5	Eject sensor PCB failure	Replace the eject sensor PCB ASSY.
6	Fuser unit failure	Replace the fuser unit.
7	Low-voltage power supply PCB failure	Replace the low-voltage power supply PCB unit.
8	Main PCB failure	Replace the main PCB ASSY.

■ **Error code 0800**

Print Unable 08
Turn the power off and then back on again.

Error occurred in the internal temperature sensor.

Step	Cause	Remedy
1	Connection failure of the internal temperature sensor harness	Reconnect the internal temperature sensor harness.
2	Main PCB failure	Replace the main PCB ASSY.

■ **Error code 0900**

Print Unable 09
Turn the power off and then back on again.

Machine detected more than 100 times that supplied power was unstable.

< **User Check** >

- Turn OFF the power switch. After several seconds, turn ON the power again and check that this error is reset.

Step	Cause	Remedy
1	Low-voltage power supply PCB failure	Replace the low-voltage power supply PCB unit. After replacing the low-voltage power supply PCB unit, refer to "1.3.37 Reset counters for parts (Function code 88)" in Chapter 5, and reset the irregular power supply detection counter of the low-voltage power supply PCB unit.
2	Main PCB failure	Replace the main PCB ASSY.

Note:

The irregular power supply detection error (Error code 0900) of the low-voltage power supply PCB unit occurs when there is a large distortion in the power supply voltage supplied to the machine. In this case, if the same power supply is used, the same error might occur again even if the low-voltage power supply PCB unit is replaced.
 For this reason, be sure to ask the user to rearrange the installation environment.

■ **Error code 0A01**

Print Unable 0A
Turn the power off and then back on again.

The blower failure was detected.

Step	Cause	Remedy
1	Connection failure of the blower harness	Reconnect the blower harness.
2	Connection failure of the high-voltage power supply PCB harness	Reconnect the high-voltage power supply PCB harness.
3	Blower failure	Replace the blower.
4	Low-voltage power supply PCB failure	Replace the low-voltage power supply PCB unit.
5	High-voltage power supply PCB failure	Replace the high-voltage power supply PCB ASSY.
6	Main PCB failure	Replace the main PCB ASSY.

■ **Error code 0A02**

Print Unable 0A
Turn the power off and then back on again.

The fuser fan failure was detected.

Step	Cause	Remedy
1	Connection failure of the fuser fan harness	Reconnect the fuser fan harness.
2	Connection failure of the high-voltage power supply PCB harness	Reconnect the high-voltage power supply PCB harness.
3	Fuser fan failure	Replace the fuser fan.
4	Low-voltage power supply PCB failure	Replace the low-voltage power supply PCB unit.
5	High-voltage power supply PCB failure	Replace the high-voltage power supply PCB ASSY.
6	Main PCB failure	Replace the main PCB ASSY.

■ **Error code 0B01**

Print Unable 0B
Turn the power off and then back on again.

Error occurred in the high-voltage power supply PCB ASSY while the machine is in operation.

Error code 0B02

Print Unable 0B
Turn the power off and then back on again.

Error occurred in the high-voltage power supply PCB ASSY in the ready state.

< User Check >

- Replace the drum unit.

Step	Cause	Remedy
1	Connection failure of the high-voltage power supply PCB harness	Reconnect the high-voltage power supply PCB harness.
2	High-voltage power supply PCB failure	Replace the high-voltage power supply PCB ASSY.
3	Main PCB failure	Replace the main PCB ASSY.

■ **Error code 0C00**

Print Unable 0C
Turn the power off and then back on again.

Error occurred in the density sensor.

Step	Cause	Remedy
1	Connection failure of the registration mark sensor L PCB harness	Reconnect the registration mark sensor L PCB harness.
2	Registration mark sensor L PCB failure	Replace the registration mark sensor unit.
3	Main PCB failure	Replace the main PCB ASSY.

■ **Error code 0E00**

Print Unable 0E
Turn the power off and then back on again.

Communication error occurred in the high-voltage power supply PCB ASSY.

Step	Cause	Remedy
1	Connection failure of the high-voltage power supply PCB harness	Reconnect the high-voltage power supply PCB harness.
2	High-voltage power supply PCB failure	Replace the high-voltage power supply PCB ASSY.
3	Main PCB failure	Replace the main PCB ASSY.

■ **Error code 1003**

Print Unable 10
Turn the power off and then back on again.

The registration mark sensor R is dirty and cannot normally receive reflected light.

< User Check >

- Clean the dirt on the belt unit or replace the belt unit.
- Replace the waste toner box.

Step	Cause	Remedy
1	Dirt on the registration mark sensor R	Clean the registration mark sensor R of the registration mark sensor R PCB.
2	Dirt by toner inside the machine	Clean inside of the machine.
3	Registration mark sensor R PCB failure	Replace the registration mark sensor unit.
4	Main PCB failure	Replace the main PCB ASSY.

■ **Error code 1004**

Print Unable 10
Turn the power off and then back on again.

The registration mark sensor L is dirty and cannot normally receive reflected light.

< User Check >

- Clean the dirt on the belt unit or replace the belt unit.
- Replace the waste toner box.

Step	Cause	Remedy
1	Dirt on the registration mark sensor L	Clean the registration mark sensor L of the registration mark sensor L PCB.
2	Dirt by toner inside the machine	Clean inside of the machine.
3	Registration mark sensor L PCB failure	Replace the registration mark sensor unit.
4	Main PCB failure	Replace the main PCB ASSY.

■ **Error code 1400**

Condensation

Leave switched ON. Fully open the Front Cover. Wait 30 minutes, switch OFF and close cover, then switch ON.

Condensation occurred in the machine.

< **User Check** >

- Open the front and back covers and leave them for 30 minutes or more with the power ON. After that, close the front and back covers and turn OFF and ON the power switch.

Step	Cause	Remedy
1	Main PCB failure	Replace the main PCB ASSY.
2	Laser unit failure	Replace the laser unit.

■ **Error code 1500**

Print Unable 15

Turn the power off and then back on again.

Error occurred in the paper eject origin sensor.

Step	Cause	Remedy
1	Connection failure of the paper eject origin sensor harness	Reconnect the paper eject origin sensor harness.
2	Paper eject origin sensor failure	Replace the paper eject origin sensor.
3	Paper eject ASSY failure	Replace the paper eject ASSY.

■ **Error code 1C00**

Print Unable EB

Turn the power off and then back on again.

The reading signal of the EEPROM of the laser unit cannot be detected.

Step	Cause	Remedy
1	Connection failure of the laser unit flat cable	Reconnect the laser unit flat cable.
2	Laser unit failure	Replace the laser unit.
3	Main PCB failure	Replace the main PCB ASSY.

■ **Error code 3801**

Print Unable 38
Turn the power off and then back on again.

Temperature error occurred in the external temperature/humidity sensor.

Error code 3802

Print Unable 38
Turn the power off and then back on again.

Humidity error occurred in the external temperature/humidity sensor.

Step	Cause	Remedy
1	Connection failure of the high-voltage power supply PCB harness	Reconnect the high-voltage power supply PCB harness.
2	External temperature/humidity sensor failure	Replace the high-voltage power supply PCB ASSY.
3	Main PCB failure	Replace the main PCB ASSY.

■ **Error code 3A00**

Print Unable 3A
Turn the power off and then back on again.

Error occurred in the communication between the controller in the main PCB and engine.

Step	Cause	Remedy
1	Main PCB failure	Replace the main PCB ASSY.

■ **Error code 4000**

Supplies
Drum End Soon.

Number of the drum unit rotations reaches the upper limit soon.

Error code 4200

Supplies
Replace Drum

Number of the drum unit rotations has reached the upper limit. (Printing is not stopped.)

< User Check >

- Prepare a new drum unit.

Step	Cause	Remedy
1	Main PCB failure if the error code remains after replacing with a new drum unit and resetting the drum counter	Replace the main PCB ASSY.

■ **Error code 4300**

Supplies
Belt End Soon

Number of pages printed with the belt unit will reach the upper limit soon. (90%)

Error code 4400

Supplies
Replace Belt

Number of pages printed with the belt unit has reached the upper limit. (Printing is not stopped.)

< **User Check** >

- Prepare a new belt unit.

Step	Cause	Remedy
1	Main PCB failure if the error code remains after replacing with a new belt unit and resetting the belt counter	Replace the main PCB ASSY.

■ **Error code 4500**

Maintenance
Replace Fuser

Number of used pages for the fuser unit has reached the upper limit. (Printing is not stopped.)

Step	Cause	Remedy
1	The fuser unit is at the end of life	Replace the fuser unit. After replacing the fuser unit, refer to "1.3.37 Reset counters for parts (Function code 88)" in Chapter 5, and reset the fuser unit counter.
2	Main PCB failure if the error code remains after replacing with a new fuser unit and resetting the fuser unit counter	Replace the main PCB ASSY.

■ **Error code 4600**

Maintenance
Replace Laser

Number of pages printed with the laser unit has reached the upper limit.

Step	Cause	Remedy
1	The laser unit is at the end of life	Replace the laser unit. After replacing the laser unit, refer to "1.3.37 Reset counters for parts (Function code 88)" in Chapter 5, and reset the laser unit counter.
2	Main PCB failure if the error code remains after replacing with a new laser unit and resetting the laser unit counter	Replace the main PCB ASSY.

■ **Error code 4700**

Supplies
WT Box End Soon

The waste toner sensor detected that the waste toner box is almost full.

Error code 4800

Replace WT Box
Replace the Waste Toner Box inside the machine.

After the waste toner sensor detected that the waste toner box was almost full, pages more than the specified number have been printed.

< User Check >

- Replace the waste toner box.

Step	Cause	Remedy
1	High-voltage power supply PCB failure	Replace the high-voltage power supply PCB ASSY.
2	Main PCB failure	Replace the main PCB ASSY.

■ **Error code 4B01**

Supplies
Toner Low:BK

Dot counter of the toner cartridge (Black) or develop roller counter reaches the upper limit soon.

Error code 4B02

Supplies
Toner Low:Y

Dot counter of the toner cartridge (Yellow) or develop roller counter reaches the upper limit soon.

Error code 4B03

Supplies
Toner Low:M

Dot counter of the toner cartridge (Magenta) or develop roller counter reaches the upper limit soon.

Error code 4B04

Supplies
Toner Low:C

Dot counter of the toner cartridge (Cyan) or develop roller counter reaches the upper limit soon.

< User Check >

- Prepare a new toner cartridge.

Step	Cause	Remedy
1	New toner actuator coming off	Re-assemble the new toner actuator.
2	Connection failure of the new toner sensor PCB harness	Reconnect the toner/new sensor PCB harness.
3	Main PCB failure	Replace the main PCB ASSY.

■ **Error code 4C01**

Replace Toner
Open the Top Cover, replace Toner Cartridge. Black (BK).

Dot counter of the toner cartridge (Black) or develop roller counter has reached the upper limit was detected.

Error code 4C02

Replace Toner
Open the Top Cover, replace Toner Cartridge. Yellow (Y).

Dot counter of the toner cartridge (Yellow) or develop roller counter has reached the upper limit was detected.

Error code 4C03

Replace Toner
Open the Top Cover, replace Toner Cartridge. Magenta (M).

Dot counter of the toner cartridge (Magenta) or develop roller counter has reached the upper limit was detected.

Error code 4C04

Replace Toner
Open the Top Cover, replace Toner Cartridge. Cyan (C).

Dot counter of the toner cartridge (Cyan) or develop roller counter has reached the upper limit was detected.

Error code 4C05

Replace Toner
Open the Top Cover, replace Toner Cartridge. Cyan (C)/ Magenta (M)/ Yellow (Y).

During printing, dot counter of color toner cartridge or develop roller counter has reached the upper limit was detected.

< User Check >

- Replace the toner cartridge whose counter reached the upper limit.

Step	Cause	Remedy
1	Main PCB failure if the error code remains after replacing with a new toner cartridge and resetting the toner counter	Replace the main PCB ASSY.

■ **Error code 4F01**

Cartridge Error
Put the Toner Cartridge back in.

The new toner sensor of the toner cartridge (Black) could not detect a new cartridge properly.

Error code 4F02

Cartridge Error
Put the Yellow #C Toner Cartridge back in.

The new toner sensor of the toner cartridge (Yellow) could not detect a new cartridge properly.

Error code 4F03

Cartridge Error
Put the Magenta #C Toner Cartridge back in.

The new toner sensor of the toner cartridge (Magenta) could not detect a new cartridge properly.

Error code 4F04

Cartridge Error
Put the Cyan #C Toner Cartridge back in.

The new toner sensor of the toner cartridge (Cyan) could not detect a new cartridge properly.

< User Check >

- Replace the toner cartridge with a new toner cartridge again.
- If the place where the machine is installed is not flat, relocate the machine to a flat place.

Step	Cause	Remedy
1	Connection failure of the new toner sensor PCB harness	Reconnect the toner/new sensor PCB harness.
2	New toner actuator that has come off or that has been caught	Re-assemble the new toner actuator.
3	New toner sensor failure	Replace the toner/new sensor PCB ASSY.
4	Main PCB failure	Replace the main PCB ASSY.

■ **Error code 5001**

Maintenance
Replace PF Kit MP

Number of used pages for the PF kit MP has reached the upper limit. (Printing is not stopped.)

Step	Cause	Remedy
1	The PF kit MP is at the end of life	Replace the PF kit MP. After replacing the PF kit MP, refer to "1.3.37 Reset counters for parts (Function code 88)" in Chapter 5, and reset the PF kit MP counter.
2	Main PCB failure if the error code remains after resetting the counter of the PF kit MP	Replace the main PCB ASSY.

■ **Error code 5002**

Maintenance
Replace PF Kit1

Number of used pages for the PF kit 1 has reached the upper limit. (Printing is not stopped.)

Step	Cause	Remedy
1	The PF kit 1 is at the end of life	Replace the PF kit 1. After replacing the PF kit 1, refer to "1.3.37 Reset counters for parts (Function code 88)" in Chapter 5, and reset the PF kit 1 counter.
2	Main PCB failure if the error code remains after resetting the counter of the PF kit 1	Replace the main PCB ASSY.

■ **Error code 5003**

Maintenance
Replace PF Kit2

Number of used pages for the PF kit 2 has reached the upper limit. (Printing is not stopped.)

Step	Cause	Remedy
1	The PF kit 2 is at the end of life	Replace the PF kit 2. After replacing the PF kit 2, refer to "1.3.37 Reset counters for parts (Function code 88)" in Chapter 5, and reset the PF kit 2 counter.
2	Main PCB failure if the error code remains after resetting the counter of the PF kit 2	Replace the main PCB ASSY.

■ **Error code 6001**

Cover is Open
Close the Front Cover.

The front cover sensor detected that the front cover was open.

< User Check >

- Close the front cover.

Step	Cause	Remedy
1	Connection failure of the front cover sensor harness	Reconnect the front cover sensor harness.
2	Front cover failure	Replace the front cover.
3	Front cover sensor failure	Replace the front cover sensor.
4	Main PCB failure	Replace the main PCB ASSY.

■ **Error code 6004**

Cover is Open
Close the Back Cover of the machine.

The eject sensor detected that the fuser cover was open.

< User Check >

- Close the fuser cover.

Step	Cause	Remedy
1	Eject actuator that has come off or that has been caught	Re-assemble the eject actuator.
2	Fuser cover installation failure	Re-assemble the fuser cover.
3	Connection failure of the eject sensor PCB harness	Reconnect the eject sensor PCB harness.
4	Eject sensor PCB failure	Replace the eject sensor PCB ASSY.
5	Main PCB failure	Replace the main PCB ASSY.

■ **Error code 6101**

No Toner
Open the Front Cover, then install Toner Cartridge. Black (BK).

The toner sensor detected that no toner cartridge (Black) was set.

Error code 6102

No Toner
Open the Front Cover, then install Toner Cartridge. Yellow (Y).

The toner sensor detected that no toner cartridge (Yellow) was set.

Error code 6103

No Toner
Open the Front Cover, then install Toner Cartridge. Magenta (M).

The toner sensor detected that no toner cartridge (Magenta) was set.

Error code 6104

No Toner
Open the Front Cover, then install Toner Cartridge. Cyan (C).

The toner sensor detected that no toner cartridge (Cyan) was set.

< User Check >

- Re-insert the toner cartridge.

Step	Cause	Remedy
1	Toner sensor failure	Replace the toner/new sensor PCB ASSY.
2	Main PCB failure	Replace the main PCB ASSY.

■ **Error code 6200**

No Drum Unit
Install the Drum Unit.

The current value between the CHG and GRID terminals and the toner sensor detected that there were no toner cartridges of any colors and detected that the drum unit was not set.

< User Check >

- Re-insert the drum unit.

Step	Cause	Remedy
1	Dirt on the GRID terminals of the main body and drum unit	Clean the GRID terminals of the main body and drum unit. (Refer to Fig. 2-7 (P2-55), Fig. 2-8 (P2-55).)
2	Dirt on the terminal of the high-voltage power supply PCB	Clean the terminal of the high-voltage power supply PCB.
3	High-voltage power supply PCB failure	Replace the high-voltage power supply PCB ASSY.
4	Toner sensor failure	Replace the toner/new sensor PCB ASSY.
5	Main PCB failure	Replace the main PCB ASSY.

■ **Electrodes location of main body**

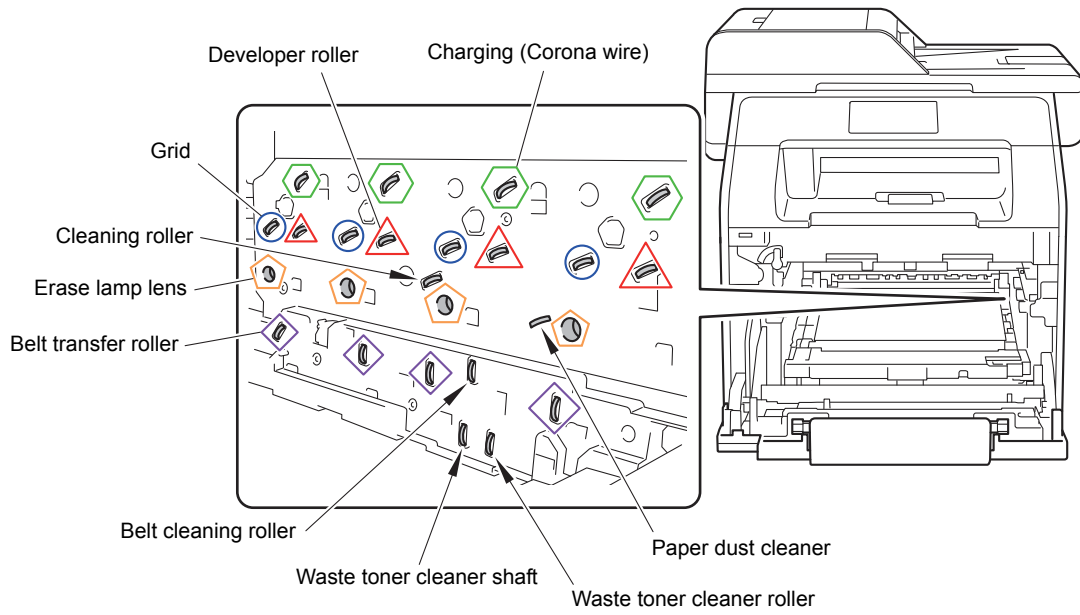

Fig. 2-7

■ **Electrodes location of the drum unit**

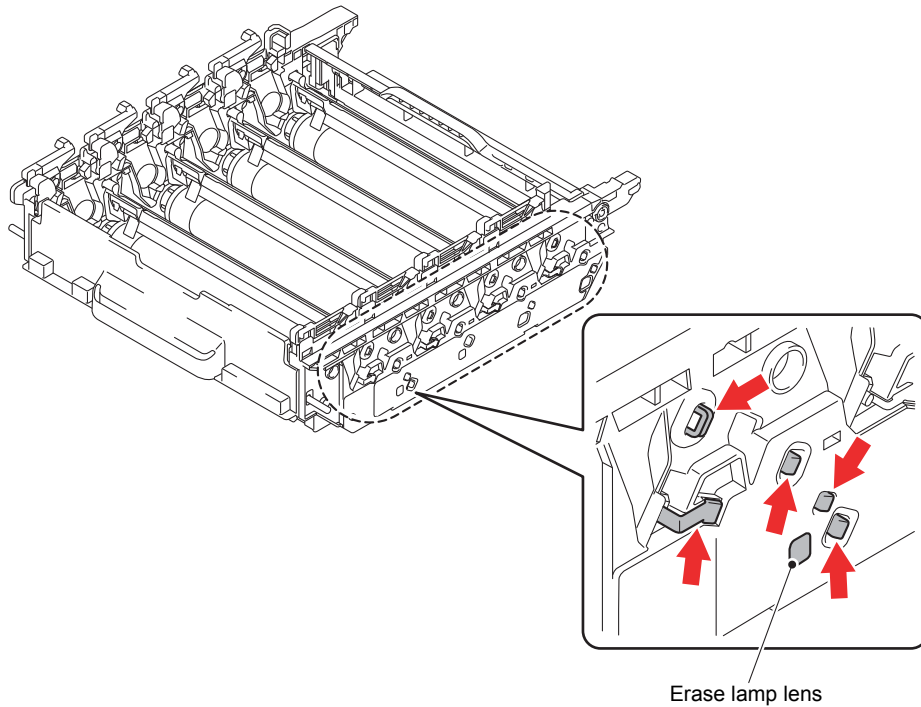

Fig. 2-8

■ **Error code 6300**

**No Waste Toner
Install the Waste Toner Box.**

The waste toner sensor detected that no waste toner box was set.

< User Check >

- Re-insert the waste toner box in the correct position.

Step	Cause	Remedy
1	High-voltage power supply PCB failure	Replace the high-voltage power supply PCB ASSY.
2	Main PCB failure	Replace the main PCB ASSY.

■ **Error code 6400**

**No Belt Unit
Open the Front Cover, pull out all Drum Units completely and install the Belt Unit.**

The registration mark sensor detected that no belt unit was set.

< User Check >

- Re-insert the belt unit.

Step	Cause	Remedy
1	Connection failure of the registration mark L PCB harness	Reconnect the registration mark sensor L PCB harness.
2	Registration mark L sensor failure	Replace the registration mark sensor unit.
3	Main PCB failure	Replace the main PCB ASSY.

■ **Error code 6801**

Cooling Down
Wait for a while

The internal temperature sensor or side thermistor of the fuser unit detected a temperature higher than the specified value.

< User Check >

- Decrease the room temperature.
- Place the machine away from a heater.

Step	Cause	Remedy
1	Connection failure of the internal temperature sensor harness	Reconnect the internal temperature sensor harness.
2	Side thermistor of the fuser unit failure	Replace the fuser unit.
3	Main PCB failure	Replace the main PCB ASSY.

■ **Error code 6901**

Self-Diagnostic
Turn the power off, then on again. Leave the machine for 15 min.

Some fuser unit errors occurred at power-ON or upon recovery from sleep mode.

Error code 6902

Self-Diagnostic
Will Automatically Restart within 15 minutes.

After the errors was detected at the fuser unit, power was turned ON again and the error is being checked. (If power is turned OFF and ON after error code 6901 occurred, this code is displayed for about 15 minutes.)

Step	Cause	Remedy
1	Connection failure of each harness of the fuser unit	Reconnect each harness of the fuser unit.
2	Connection failure of the eject sensor PCB harness	Reconnect the eject sensor PCB harness.
3	Fuser unit failure	Replace the fuser unit.
4	Eject sensor PCB failure	Replace the eject sensor PCB ASSY.
5	Low-voltage power supply PCB failure	Replace the low-voltage power supply PCB unit.
6	Main PCB failure	Replace the main PCB ASSY.

Note:

- Turn OFF the power switch. After checking that the fuser unit has cooled sufficiently, turn ON the power switch again and leave the machine for ten minutes. This problem may then be cleared.
- To clear the fuser unit error after the remedy of the error is taken, enter the maintenance mode and then exit from the maintenance mode using Function code 99.

■ **Error code 6A00**

Drum !
Slide the Blue tab on Drum Unit.

Electric discharge that may be caused by dirt on the corona wire of the drum unit was detected.

Error code 6B01

Drum Stop
Replace the Drum Unit.

Electric discharge was detected when the number of the drum unit rotations had become more than twice of the upper limit.

< User Check >

- Clean the corona wire by sliding the blue tab of the drum unit for all four colors several times.
- Clean the terminal of the drum unit. (Refer to [Fig. 2-8 \(P2-55\)](#).)
- Replace the drum unit.

Step	Cause	Remedy
1	Dirt on the GRID terminals of the main body	Clean the GRID terminals of the main body. (Refer to Fig. 2-7 (P2-55) .)
2	Dirt on the terminal of the high-voltage power supply PCB	Clean the terminal of the high-voltage power supply PCB.
3	High-voltage power supply PCB failure	Replace the high-voltage power supply PCB ASSY.
4	Main PCB failure	Replace the main PCB ASSY.

■ **Error code 6C02**

Tray 2 Error
Take out Tray 2 and push it back in firmly.

After the T2 paper tray unit is opened and closed or the power is turned ON, the T2 plate origin sensor detects that lift-up of the plate of the T2 paper tray unit is not completed within the specified period of time.

< User Check >

- Open the T2 paper tray unit and close the T2 paper tray unit correctly.

Step	Cause	Remedy
1	Connection failure of the T2 plate origin sensor harness	Reconnect the T2 plate origin sensor harness.
2	T2 relay PCB failure	Replace the T2 relay PCB ASSY.
3	T2 plate origin sensor failure	Replace the T2 paper tray unit.
4	Main PCB failure	Replace the main PCB ASSY.

■ **Error code 6E00**

Toner Error
One or more Toner Cartridges are not detected. Pull out and reinsert all 4 Toner Cartridges.

The develop release sensor detected the developer roller disengagement or engagement failure.

Step	Cause	Remedy
1	Connection failure of the develop release sensor harness	Reconnect the develop release sensor harness.
2	Develop release sensor failure	Replace the develop release sensor PCB ASSY.
3	Develop release clutch failure	Replace the develop release drive unit.
4	Main PCB failure	Replace the main PCB ASSY.

■ **Error code 6F00**

Print Unable ZC
Turn the power off and then back on again.

Machine detected that supplied power was unstable. (Less than 100 times)

< **User Check** >

- Turn the power switch OFF/ON.
- Insert the filter into the power supply.

Step	Cause	Remedy
1	The power supply waveform is incorrect	Install a voltage stabilizer in the power supply part.

■ **Error code 7000**

Jam Inside
Open the Front Cover, pull out all four drum and toner cartridge assemblies and remove the jammed paper.

After the registration rear sensor detects paper pass, the eject sensor does not detect paper pass.

< **User Check** >

- Remove the jammed paper.

Step	Cause	Remedy
1	Foreign object inside machine	Remove the foreign object.
2	Eject actuator that has come off or that has been caught	Re-assemble the eject actuator.
3	Fuser cover installation failure	Re-assemble the fuser cover.
4	Connection failure of the eject sensor PCB harness	Reconnect the eject sensor PCB harness.
5	Fuser drive gear Z25 damaged	Replace the fuser drive gear Z25.
6	Process related feed gear damaged	Replace the process drive unit.
7	Paper feed related gear damaged	Replace the main drive unit.
8	Eject sensor failure	Replace the eject sensor PCB ASSY.
9	Fuser unit failure	Replace the fuser unit.
10	Main PCB failure	Replace the main PCB ASSY.

■ Error code 7100

Jam Rear

Open the Back Cover and remove the jammed paper, then press [Start].

After the registration rear sensor detects the end of paper pass and the specified period of time has passed, the eject sensor continues to detect paper pass.

< User Check >

- Remove the jammed paper.
- Check if the back cover is not open during 2-sided printing.

Step	Cause	Remedy
1	Foreign object at the back of the machine	Remove the foreign object.
2	Eject actuator caught on some position	Re-assemble the eject actuator.
3	Fuser cover installation failure	Re-assemble the fuser cover.
4	Back cover installation failure	Re-assemble the back cover.
5	Eject sensor failure	Replace the eject sensor PCB ASSY.
6	Back cover failure	Replace the back cover.
7	Fuser drive gear Z25 damaged	Replace the fuser drive gear Z25.
8	Paper eject ASSY failure	Replace the paper eject ASSY.
9	Paper feed related gear damaged	Replace the main drive unit.
10	Fuser unit failure	Replace the fuser unit.
11	Main PCB failure	Replace the main PCB ASSY.

■ Error code 7200

Jam MP Tray

Remove the jammed paper from MP Tray and press [Retry].

When the paper is fed from the MP tray, after the MP registration front sensor detects paper pass, the registration rear sensor does not detect paper pass after a set period of time.

< User Check >

- Remove the jammed paper.
- Insert the papers straight using the paper guide of the MP tray.
- Check if the papers loaded in the MP tray is not held down with your hand.
- Check if the double feed occurs in the MP tray.
- Check if the front cover is closed correctly.
- Check if the machine is used with the MP tray support and MP flap are in closed state.

Step	Cause	Remedy
1	Foreign object at the back of the machine	Remove the foreign object.
2	Registration rear actuator that has come off or that has been caught	Re-assemble the registration rear actuator.
3	Connection failure of the registration front/rear sensor PCB harness	Reconnect the registration front/rear sensor PCB harness.
4	MP unit installation failure	Re-assemble the MP unit.
5	MP separation pad worn out	Replace the PF kit MP.
6	Registration rear sensor failure	Replace the registration front/rear sensor PCB.
7	Paper feed related gear damaged	Replace the main drive unit.
8	Main PCB failure	Replace the main PCB ASSY.

■ **Error code 7300**

Jam Tray 1
Pull the paper tray1 completely out of the machine and remove the jammed paper.

In the case of printing by feeding paper from the paper tray 1, after the T1 paper feed sensor detects paper pass, the registration front sensor does not detect paper pass after a set period of time.

< User Check >

- Remove the jammed paper.
- Check if the paper tray 1 is closed correctly.

Step	Cause	Remedy
1	Foreign object at the front of the paper tray 1	Remove the foreign object.
2	T1 paper dust cleaning roller installation failure	Re-assemble the T1 paper dust cleaning roller.
3	Registration front actuator that has come off or that has been caught	Re-assemble the registration front actuator.
4	Connection failure of the registration front/rear sensor PCB harness	Reconnect the registration front/rear sensor PCB harness.
5	Registration front sensor failure	Replace the registration front/rear sensor PCB ASSY.
6	Paper feed related gear damaged	Replace the main drive unit.
7	Main PCB failure	Replace the main PCB ASSY.

■ **Error code 7400**

Jam Tray 2
Pull the paper tray2 completely out of the machine and remove the jammed paper.

In the case of printing by feeding paper from the T2 paper tray unit, after the T2 paper feed sensor detects paper pass, the registration front sensor does not detect paper pass after a set period of time.

< User Check >

- Remove the jammed paper.
- Close the paper tray 1 and T2 paper tray unit correctly.

Step	Cause	Remedy
1	Foreign object at the front of the paper tray 1	Remove the foreign object.
2	Foreign object at the front of the T2 paper tray unit	Remove the foreign object.
3	T1/T2 paper dust cleaning roller installation failure	Re-assemble the T1/T2 paper dust cleaning roller.
4	Registration front actuator that has come off or that has been caught	Re-assemble the registration front actuator.
5	Connection failure of the registration front/rear sensor PCB harness	Reconnect the registration front/rear sensor PCB harness.
6	Registration front sensor failure	Replace the registration front/rear sensor PCB ASSY.
7	Paper feed related gear damaged	Replace the main drive unit.
8	Main PCB failure	Replace the main PCB ASSY.

■ **Error code 7700**

Jam 2-sided
Pull the paper tray completely out of the machine. Check inside the machine towards the rear. Or open the Back Cover to remove the jammed paper.

After the first side is printed in 2-sided printing mode, the registration front sensor does not detect paper pass after a set period of time.

< User Check >

- Remove the jammed paper.
- Check if the back cover is closed correctly.
- Check if the paper tray 1 is closed correctly.

Step	Cause	Remedy
1	Foreign object inside the duplex path	Remove the foreign object.
2	Foreign object inside the duplex path of the paper tray 1	Remove the foreign object.
3	Fuser cover installation failure	Re-assemble the fuser cover.
4	Back cover installation failure	Re-assemble the back cover.
5	Main PCB failure	Replace the main PCB ASSY.

■ **Error code 8402**

No Tray
The paper tray cannot be detected, re-install Tray2.

While the T2 paper tray unit is open state, print or adjustment operation was attempted.

< User Check >

- Check if the T2 paper tray unit is closed correctly.

Step	Cause	Remedy
1	T2 paper feed actuator that has come off or that has been caught	Re-assemble the T2 paper feed actuator.
2	Main PCB failure	Replace the main PCB ASSY.

■ **Error code 8501**

No Tray
The paper tray cannot be detected, re-install Tray1.

The T1 paper feed sensor detected that the paper tray 1 is open in 2-sided printing or printing by feeding paper from the T2 paper tray unit. (before the registration of printing in the engine)

Error code 8505

No Tray
The paper tray cannot be detected, re-install Tray1.

The T1 paper feed sensor detected that the paper tray 1 is open in 2-sided printing or printing by feeding paper from the T2 paper tray unit. (after the registration of printing in the engine)

< User Check >

- Check if the paper tray 1 is closed correctly.

Step	Cause	Remedy
1	T1 paper feed actuator that has come off or that has been caught	Re-assemble the T1 paper feed actuator.
2	Connection failure of the T1 paper feed sensor PCB harness	Reconnect the T1 paper feed sensor PCB harness.
3	T1 paper feed sensor failure	Replace the T1 paper feed sensor PCB ASSY.
4	Main PCB failure	Replace the main PCB ASSY.

■ **Error code 8903**

2-sided Disabled
Close the Back Cover of the Machine.

The back cover sensor detected the open state when 2-sided printing is started. (before the registration of printing in the engine)

Error code 8904

2-sided Disabled
Close the Back Cover of the Machine.

The back cover sensor detected the open state during 2-sided printing. (after the registration of printing in the engine)

< User Check >

- Close the back cover.

Step	Cause	Remedy
1	Connection failure of the back cover sensor harness	Reconnect the back cover sensor harness.
2	Back cover sensor installation failure	Re-assemble the back cover sensor.
3	Breakage of boss that presses the back cover sensor	Replace the back cover.
4	Back cover sensor failure	Replace the back cover sensor ASSY.
5	Main PCB failure	Replace the main PCB ASSY.

■ **Error code 8A01**

Size Error 2-sided
Specify the correct paper.

The registration rear sensor detected that the fed paper was larger or smaller than the specified size in 2-sided printing.

Error code 8A02

2-sided Disabled
Reload paper, then press Start.

The registration rear sensor detected that the length of the paper is too long and it may hit within the machine in 2-sided printing.

< User Check >

- Use the Letter to Legal size paper.

Step	Cause	Remedy
1	Registration rear actuator caught on some position	Re-assemble the registration rear actuator.
2	Registration rear sensor failure	Replace the registration front/rear sensor PCB ASSY.
3	Main PCB failure	Replace the main PCB ASSY.

■ **Error code 8D01**

Short paper
Open the Back Cover and then press [Retry].

The registration rear sensor detected that the paper loaded in the paper tray was smaller than the specified size.

< User Check >

- Open the back cover and print using the straight paper path.
- Length of the paper is 114 mm or more.

Step	Cause	Remedy
1	Registration rear actuator caught on some position	Re-assemble the registration rear actuator.
2	Registration rear sensor failure	Replace the registration front/rear sensor PCB ASSY.
3	Main PCB failure	Replace the main PCB ASSY.

■ **Error code 8D02**

Small paper
Open the Back Cover and then press [Retry].

The paper size which is not supported by the output tray is set for printing from the printer driver.

< User Check >

- The size of paper actually loaded and the one specified from the driver shall be the one within the specified range.
- Open the back cover and print using the straight paper path.

Step	Cause	Remedy
1	Main PCB failure	Replace the main PCB ASSY.

■ **Error code 8E02**

Size Mismatch
Reload correct paper.

Upon fax reception, the paper size setting is the one other than A4, Letter, Legal, and Folio.

< User Check >

- Set the paper size of the driver to A4, Letter, Legal, or Folio.

Step	Cause	Remedy
1	Main PCB failure	Replace the main PCB ASSY.

■ **Error code 9001**

Size mismatch
Reload correct paper in MP Tray, then press [Retry].

The size of paper loaded in the MP tray and the one specified from the driver are not same when paper is fed from the MP tray.

Error code 9002

Size mismatch
Reload correct paper in Tray1,then press [Retry].

The size of paper loaded in the paper tray 1 and the one specified from the driver are not same when paper is fed from the paper tray 1.

Error code 9003

Size mismatch
Reload correct paper in Tray2,then press [Retry].

The size of paper loaded in the T2 paper tray unit and the one specified from the driver are not same when paper is fed from the T2 paper tray unit.

< User Check >

- When specifying the paper in the driver, set the paper size of the paper that is actually set.

Step	Cause	Remedy
1	Registration rear actuator caught on some position	Re-assemble the registration rear actuator.
2	Registration rear sensor failure	Replace the registration front/rear sensor PCB ASSY.
3	Main PCB failure	Replace the main PCB ASSY.

■ **Error code 9301**

No Paper
Reload paper in MP Tray.

When paper was fed from the MP tray, the MP paper empty sensor detected that no paper was in the MP tray.

< User Check >

- Load paper to the MP tray.

Step	Cause	Remedy
1	MP paper empty actuator caught on some position	Re-assemble the MP paper empty actuator.
2	Connection failure of the MP paper empty/registration front sensor PCB harness	Reconnect the MP paper empty/registration front sensor PCB harness.
3	MP paper empty sensor failure	Replace the MP paper empty/registration front sensor PCB ASSY.
4	Main PCB failure	Replace the main PCB ASSY.

■ **Error code 9302**

No Paper
Reload paper in Tray 1.

When paper was fed from the paper tray 1, the T1 paper feed sensor detected that no paper was in the paper tray 1.

< User Check >

- Load paper to the paper tray.

Step	Cause	Remedy
1	T1 paper feed actuator caught on some position	Re-assemble the T1 paper feed actuator.
2	Connection failure of the T1 paper feed sensor PCB harness	Reconnect the T1 paper feed sensor PCB harness.
3	T1 paper feed sensor failure	Replace the T1 paper feed sensor PCB ASSY.
4	Main PCB failure	Replace the main PCB ASSY.

■ **Error code 9303**

No Paper
Reload paper in Tray 2.

When paper was fed from the T2 paper tray unit, the T2 paper feed sensor detected that no paper was in the T2 paper tray unit.

< User Check >

- Load paper to the paper tray.

Step	Cause	Remedy
1	T2 paper feed actuator caught on some position	Re-assemble the T2 paper feed actuator.
2	Connection failure of the T2 paper feed sensor PCB harness	Reconnect the T2 paper feed sensor PCB harness.
3	Connection failure of the T2 relay PCB harness	Reconnect the T2 relay PCB harness.
4	T2 relay PCB failure	Replace the T2 relay PCB ASSY.
5	T2 connector failure	Replace the T2 paper tray unit.
6	Main PCB failure	Replace the main PCB ASSY.

■ **Error code 9306**

No Paper
Reload paper in Tray.

For printing specifying Auto, it was detected that no paper was loaded in any of the paper trays.

< User Check >

- Load paper to any tray.

Step	Cause	Remedy
1	MP paper empty actuator caught on some position	Re-assemble the MP paper empty actuator.
2	T1 paper feed actuator caught on some position	Re-assemble the T1 paper feed actuator.
3	T2 paper feed actuator caught on some position	Re-assemble the T2 paper feed actuator.
4	Connection failure of the MP paper empty/registration front sensor PCB harness	Reconnect the MP paper empty/registration front sensor PCB harness.
5	Connection failure of the T1 paper feed sensor PCB harness	Reconnect the T1 paper feed sensor PCB harness.
6	Connection failure of the T2 paper feed sensor PCB harness	Reconnect the T2 paper feed sensor PCB harness.
7	MP paper empty sensor failure	Replace the MP paper empty/registration front sensor PCB ASSY.
8	T1 paper feed sensor failure	Replace the T1 paper feed sensor PCB ASSY.
9	T2 connector failure	Replace the T2 paper tray unit.
10	Main PCB failure	Replace the main PCB ASSY.

■ **Error code 9307**

**No Paper
Load paper in Tray.**

Upon receiving a fax or printing a list or report, the machine detected that paper tray empty of paper.

< User Check >

- Load paper to any tray.

Step	Cause	Remedy
1	MP paper empty actuator caught on some position	Re-assemble the MP paper empty actuator.
2	T1 paper feed actuator caught on some position	Re-assemble the T1 paper feed actuator.
3	T2 paper feed actuator caught on some position	Re-assemble the T2 paper feed actuator.
4	Connection failure of the MP paper empty/registration front sensor PCB harness	Reconnect the MP paper empty/registration front sensor PCB harness.
5	Connection failure of the T1 paper feed sensor PCB harness	Reconnect the T1 paper feed sensor PCB harness.
6	Connection failure of the T2 paper feed sensor PCB harness	Reconnect the T2 paper feed sensor PCB harness.
7	MP paper empty sensor failure	Replace the MP paper empty/registration front sensor PCB ASSY.
8	T1 paper feed sensor failure	Replace the T1 paper feed sensor PCB ASSY.
9	T2 connector failure	Replace the T2 paper tray unit.
10	Main PCB failure	Replace the main PCB ASSY.

■ **Error code 9701**

Size Error 2-sided
Press [OK]. Specify the correct paper and load the same size paper as the Printer driver setting.

For 2-sided printing, the tray whose paper size was not supported by 2-sided printing was selected.

Error code 9702

Size Error
Specify the correct paper size for Tray 1.

For printing by feeding paper from the paper tray 1, the size of paper specified from the driver set the size which was not supported by the paper tray 1.

Error code 9703

Size Error
Specify the correct paper size for Tray 2.

For printing by feeding paper from the T2 paper tray unit, the size of paper specified from the driver set the size which was not supported by the T2 paper tray unit.

< User Check >

- The size of the paper specified from the driver shall be A4 or Letter size and load the same size of paper to the specified paper tray.

Step	Cause	Remedy
1	Main PCB failure	Replace the main PCB ASSY.

■ **Error code 9801**

Calibration
Calibration failed. Turn the power off and then back on again.

Error occurred with the value measured during color density adjustment performed from the control panel.

< User Check >

- Check if the toner cartridges are set in the correct order of colors.
- Replace the toner cartridge.
- Replace the drum unit.
- If the belt unit has a scratch, replace it.
- If "WT Box End Soon" is displayed on the LCD and the belt unit has dirt, replace the waste toner box.

Step	Cause	Remedy
1	Dirt on the registration mark sensor L	Clean the registration mark sensor L.
2	Failure in printed measurement pattern image	If failure occurs when printing "2D3S YM CBW KW_A" in "Function code 71", refer to "4.3 Troubleshooting for Image Defects" in this chapter and take a measure.
3	Connection failure of the registration mark sensor L PCB harness	Reconnect the registration mark sensor L PCB harness.
4	Density sensor failure	Replace the registration mark sensor unit.
5	Main PCB failure	Replace the main PCB ASSY.

■ **Error code 9802**

Calibration
Calibration failed. Insufficient Toner for Calibration.

Dot counter or develop roller counter of color toner has reached the upper limit during color density adjustment performed from the control panel.

< User Check >

- Replace the corresponding toner cartridge.

Step	Cause	Remedy
1	Main PCB failure	Replace the main PCB ASSY.

■ **Error code 9803**

Calibration
Calibration failed. Press [Retry], and try again.

Density patch measurement ended unsuccessfully during color density adjustment performed from the control panel.

Error code 9804

Calibration
Calibration failed. Press [Retry], and try again.

Error occurred with the value measured during density sensor sensitivity calibration.

< User Check >

- Check if the toner cartridges are set in the correct order of colors.
- Replace the toner cartridge.
- Replace the drum unit.
- If the belt unit has a scratch, replace it.
- If “WT Box End Soon” is displayed on the LCD and the belt unit has dirt, replace the waste toner box.

Step	Cause	Remedy
1	Dirt on the registration mark sensor L	Clean the registration mark sensor L.
2	Failure in printed measurement pattern image	If failure occurs when printing “2D3S YMCBWKW_A” in “ Function code 71 ”, refer to “ 4.3 Troubleshooting for Image Defects ” in this chapter and take a measure.
3	Connection failure of the registration mark sensor L PCB harness	Reconnect the registration mark sensor L PCB harness.
4	Density sensor failure	Replace the registration mark sensor unit.
5	Main PCB failure	Replace the main PCB ASSY.

■ **Error code 9A01**

Registration
Registration failed. Turn the power off and then back on again.

Error occurred with the value measured during auto color registration performed from the control panel.

< User Check >

- Check if the toner cartridges are set in the correct order of colors.
- Replace the toner cartridge.
- Replace the drum unit.
- If the belt unit has a scratch, replace it.
- If “WT Box End Soon” is displayed on the LCD and the belt unit has dirt, replace the waste toner box.

Step	Cause	Remedy
1	Dirt on the registration mark sensor L/registration mark sensor R	Clean the registration mark sensor L/ registration mark sensor R.
2	Connection failure of the registration mark sensor L PCB/ registration mark sensor R PCB harness	Reconnect the registration mark sensor L PCB/registration mark sensor R PCB harness.
3	Failure in printed measurement pattern image	If failure occurs when printing “2D3S YMCBWKW_A” in “Function code 71”, refer to “4.3 Troubleshooting for Image Defects” in this chapter and take a measure.
4	Registration mark sensor L or registration mark sensor R failure	Replace the registration mark sensor unit.
5	Main PCB failure	Replace the main PCB ASSY.

■ **Error code 9A02**

Registration
Registration failed. Insufficient Toner for Registration.

Dot counter or develop roller counter of color toner has reached the upper limit during auto color registration performed from the control panel.

< User Check >

- Replace the corresponding toner cartridge.

Step	Cause	Remedy
1	Main PCB failure	Replace the main PCB ASSY.

■ **Error code 9A03**

Registration
Registration failed. Press [Retry], and try again.

Error occurred during patch data printing in auto color registration performed from the control panel.

< User Check >

- Check if the toner cartridges are set in the correct order of colors.
- Replace the toner cartridge.
- Replace the drum unit.
- If the belt unit has a scratch, replace it.
- If “WT Box End Soon” is displayed on the LCD and the belt unit has dirt, replace the waste toner box.

Step	Cause	Remedy
1	Dirt on the registration mark sensor L/registration mark sensor R	Clean the registration mark sensor L/ registration mark sensor R.
2	Connection failure of the registration mark sensor L PCB/ registration mark sensor R PCB harness	Reconnect the registration mark sensor L PCB/registration mark sensor R PCB harness.
3	Failure in printed measurement pattern image	If failure occurs when printing “2D3S YMCBWKW_A” in “Function code 71”, refer to “4.3 Troubleshooting for Image Defects” in this chapter and take a measure.
4	Registration mark sensor L or registration mark sensor R failure	Replace the registration mark sensor unit.
5	Main PCB failure	Replace the main PCB ASSY.

■ **Error code A000**

Scan Unable
Remove the original document. Turn the power off, then on again.

Upon scanning the second side in duplex scanning, scanned data cannot be output with the required number of pixels and image processing is not completed successfully.

Step	Cause	Remedy
1	Second side CIS unit calibration data error	Perform “Function code 55”. (Refer to “1.3.19 Acquisition of white level data and setting of CIS scanning area (Function code 55)” in this chapter.)
2	Second side CIS unit failure	Replace the second side CIS unit.
3	Main PCB failure	Replace the main PCB ASSY.

■ Error code A200

Document Jam
Clear the scanner jam, then press the Stop Key.

During document scanning, the first side document scanning position sensor detected that the document length was 90 cm or more.

< User Check >

- Use documents equal to or smaller than A4 size.
- Remove the jammed paper.

Step	Cause	Remedy
1	First side document scanning position actuator catching on some position	Re-assemble the first side document scanning position actuator.
2	First side document scanning position sensor failure	Replace the first side document scanning position sensor PCB.
3	Main PCB failure	Replace the main PCB ASSY.

■ Error code A300

Document Jam
Clear the scanner jam, then press the Stop Key.

Though a document was fed and conveyed by the specified distance or longer, the first side document scanning position sensor did not detect the passing of the paper.

< User Check >

- Match the document guide with the document size.
- Remove the jammed paper.

Step	Cause	Remedy
1	First side document scanning position actuator catching on some position	Re-assemble the first side document scanning position actuator.
2	Connection failure of the first side document scanning position sensor PCB harness	Reconnect the first side document scanning position sensor PCB harness.
3	First side document scanning position sensor failure	Replace the first side document scanning position sensor PCB.
4	Main PCB failure	Replace the main PCB ASSY.

■ **Error code A400**

Cover is Open
Close the ADF Cover. / Close the ADF Cover, then press Stop[X].

The ADF cover sensor detected that the ADF cover was opened.

< User Check >

- Firmly close the ADF cover.

Step	Cause	Remedy
1	ADF cover actuator caught on some position	Re-assemble the ADF cover actuator.
2	ADF cover/document detection sensor PCB installation failure	Re-assemble the ADF cover/document detection sensor PCB ASSY.
3	Connection failure of the ADF cover/document detection sensor PCB harness	Reconnect the ADF cover/document detection sensor PCB harness.
4	ADF cover damaged	Replace the ADF cover.
5	ADF cover sensor failure	Replace the ADF cover/document detection sensor PCB ASSY.
6	Main PCB failure	Replace the main PCB ASSY.

■ **Error code A500**

Scan Unable
Remove the original document. Turn the power off, then on again.

Upon scanning a fax, the first side CIS white or black calibration data was not within the normal range.

Error code A600

Scan Unable A6
Turn the power off and then back on again.

Though a fax was scanned again after A500 error, the first side CIS white or black calibration data was not within the normal range.

Step	Cause	Remedy
1	First side CIS unit calibration data error	Perform "Function code 55". (Refer to "1.3.19 Acquisition of white level data and setting of CIS scanning area (Function code 55)" in this chapter.)
2	First side CIS flat cable damaged	Replace the first side CIS flat cable.
3	First side CIS unit failure	Replace the first side CIS unit.
4	Main PCB failure	Replace the main PCB ASSY.

■ **Error code A700**

Print Unable A7
Turn the power off and then back on again.

The ROM color parameter does not match the first side CIS or second side CIS.

■ **Error code A900**

Scan Unable A9
 -

When an image was scanned and processed, a scanning error occurred.

Step	Cause	Remedy
1	First side or second side CIS unit calibration data error	Perform "Function code 55". (Refer to "1.3.19 Acquisition of white level data and setting of CIS scanning area (Function code 55)" in this chapter.)
2	First side CIS flat cable damaged	Replace the first side CIS flat cable.
3	Second side CIS flat cable damaged	Replace the second side CIS flat cable.
4	First side CIS unit failure	Replace the first side CIS unit.
5	Second side CIS unit failure	Replace the second side CIS unit.
6	Main PCB failure	Replace the main PCB ASSY.

■ **Error code AC00**

Scan Unable
Remove the original document. Turn the power off, then on again.

Upon scanning a fax, the second side white or black calibration data was not within the normal range.

Step	Cause	Remedy
1	Second side CIS unit calibration data error	Perform "Function code 55". (Refer to "1.3.19 Acquisition of white level data and setting of CIS scanning area (Function code 55)" in this chapter.)
2	Second side CIS flat cable damaged	Replace the second side CIS flat cable.
3	Second side CIS unit failure	Replace the second side CIS unit.
4	Main PCB failure	Replace the main PCB ASSY.

■ **Error code AD00**

Scan Unable
Remove the original document. Turn the power off, then on again.

First side scanned data cannot be output with the required number of pixels, and image processing cannot be completed successfully.

Step	Cause	Remedy
1	First side CIS unit calibration data error	Perform "Function code 55". (Refer to "1.3.19 Acquisition of white level data and setting of CIS scanning area (Function code 55)" in this chapter.)
2	First side CIS flat cable damaged	Replace the first side CIS flat cable.
3	First side CIS unit failure	Replace the first side CIS unit.
4	Main PCB failure	Replace the main PCB ASSY.

■ **Error code AF00**

Scan Unable AF
Turn the power off and then back on again.

The first side CIS fails to move, remaining at the home position.

Step	Cause	Remedy
1	Dust adhered to guide shaft	Remove the dust from the guide shaft.
2	Coming off of CIS drive belt	Re-assemble the CIS drive belt.
3	Wiring failure of first side CIS flat cable	Re-assemble the first side CIS flat cable.
4	Connection failure of the document scanner motor harness	Reconnect the document scanner motor harness.
5	First side CIS flat cable damaged	Replace the first side CIS flat cable.
6	First side CIS unit failure	Replace the first side CIS unit.
7	Document scanner motor failure	Replace the document scanner unit.
8	Main PCB failure	Replace the main PCB ASSY.

■ **Error code B000**

SCANNER ERROR FB / SCANNER ERROR ADF
-

The first or second side CIS flat cable was detected to be not inserted correctly.

Step	Cause	Remedy
1	Connection failure of the first side CIS flat cable	Reconnect the first side CIS flat cable.
2	Connection failure of the second side CIS flat cable	Reconnect the second side CIS flat cable.
3	First side CIS flat cable damaged	Replace the first side CIS flat cable.
4	Second side CIS flat cable damaged	Replace the second side CIS flat cable.
5	First side CIS unit failure	Replace the first side CIS unit.
6	Second side CIS unit failure	Replace the second side CIS unit.
7	Main PCB failure	Replace the main PCB ASSY.

■ **Error code BB00**

Scanner Error BB
-

The white level value obtained with function code 55 was outside the specified range.

Step	Cause	Remedy
1	First side or second side CIS unit calibration data error	Perform "Function code 55". (Refer to "1.3.19 Acquisition of white level data and setting of CIS scanning area (Function code 55)" in this chapter.)
2	First side CIS flat cable damaged	Replace the first side CIS flat cable.
3	Second side CIS flat cable damaged	Replace the second side CIS flat cable.
4	First side CIS unit failure	Replace the first side CIS unit.
5	Second side CIS unit failure	Replace the second side CIS unit.
6	Main PCB failure	Replace the main PCB ASSY.

■ **Error code BC00**

Scan Unable BC
Turn the power off and then back on again.

Though a fax was scanned again after AC00 error, the second side white or black calibration data was not within the normal range.

Step	Cause	Remedy
1	Second side CIS unit calibration data error	Perform "Function code 55". (Refer to "1.3.19 Acquisition of white level data and setting of CIS scanning area (Function code 55)" in this chapter.)
2	Second side CIS flat cable damaged	Replace the second side CIS flat cable.
3	Second side CIS unit failure	Replace the second side CIS unit.
4	Main PCB failure	Replace the main PCB ASSY.

■ **Error code BD00**

Scanner Error BD
 -

The black level value obtained with function code 55 was outside the specified range.

Step	Cause	Remedy
1	First side or second side CIS unit calibration data error	Perform "Function code 55". (Refer to "1.3.19 Acquisition of white level data and setting of CIS scanning area (Function code 55)" in this chapter.)
2	First side CIS flat cable damaged	Replace the first side CIS flat cable.
3	Second side CIS flat cable damaged	Replace the second side CIS flat cable.
4	First side CIS unit failure	Replace the first side CIS unit.
5	Second side CIS unit failure	Replace the second side CIS unit.
6	Main PCB failure	Replace the main PCB ASSY.

■ **Error code BF00**

Scan Unable
Document is too long for 2-sided scanning. Press Stop key.

The first side document scanning position sensor detected that the document was 400 mm or more in length and could not be fed from the ADF in duplex feeding.

< User Check >

- Use A4 or Letter size document.
- Remove the jammed paper.

Step	Cause	Remedy
1	First side document scanning position actuator catching on some position	Re-assemble the first side document scanning position actuator.
2	First side document scanning position sensor failure	Replace the first side document scanning position sensor PCB.
3	Main PCB failure	Replace the main PCB ASSY.

■ **Error code C001**

**Log Access Error.
Server Timeout, contact your administrator.**

Timeout occurred with access request sent to server due to incorrect server address, network disconnection, or inactive server.

Error code C002

**Log Access Error.
Authentication Error, contact your administrator.**

User authentication is unavailable due to incorrect user name, incorrect password, or asynchronous date and time between the machine and server.

Error code C003

**Log Access Error.
File Access Error, contact your administrator.**

Access to a file is unavailable due to incorrect directory name, no write permission on directory, file write lock, or no write permission on file.

Error code C004

**Log Access Error.
Wrong Date&Time, contact your administrator.**

The current time necessary for user authentication is unavailable due to time not being obtained.

< User Check >

- Refer to User's guide and reconfigure network settings.
- Check the wiring of the LAN cables.
- Check the wireless LAN settings.

Step	Cause	Remedy
1	Connection failure of the wireless LAN PCB connector	Reconnect the Wireless LAN PCB connector.
2	Wireless LAN PCB failure	Replace the wireless LAN PCB ASSY.
3	Main PCB failure	Replace the main PCB ASSY.

■ **Error code C700**

**Out of Memory
Press Stop Key**

The memory is insufficient to expand the data of PC-Print.

Error code C800

**Print Data Full
Print Data is full. Press Stop[X] Key and delete the previously stored data.**

The memory used to store secure print data exceeded the memory size for secure print data.

< User Check >

- Print the print data stored in the memory.
- Divide the print data and print it.

Step	Cause	Remedy
1	Main PCB failure	Replace the main PCB ASSY.

■ **Error code D100**

**Print Unable D1
Turn the power off and then back on again.**

An error occurred during modem initialization.

Error code D200

Machine Error

-

The machine detected that the modem PCB was disconnected.

Step	Cause	Remedy
1	Connection failure of the modem PCB flat cable	Reconnect the modem PCB flat cable.
2	Modem PCB failure	Replace the modem PCB ASSY.
3	Main PCB failure	Replace the main PCB ASSY.

■ **Error code D800**

Touchscreen initialization failed
Remove any material which is on the touchscreen.

Error occurred during touch panel initialization.

Error code D900

-
-

Communication between the panel PCB and main PCB is unavailable during touch panel initialization.

Error code DA00

-
-

After the initialization of the panel PCB, no response was sent from the panel PCB for a period of time.

Error code DB00

Print Unable DB
Turn the power off and then back on again.

USB communication between the main PCB and panel PCB is unavailable.

Step	Cause	Remedy
1	The version of the panel firmware and the main firmware do not match	Install the latest panel firmware and main firmware.
2	Connection failure of the panel PCB harness	Reconnect the panel PCB harness.
3	Connection failure of the touch panel flat cable	Reconnect the touch panel flat cable.
4	Connection failure of the Key PCB flat cable	Reconnect the key PCB flat cable.
5	Panel PCB failure	Replace the panel PCB unit.
6	Touch panel ASSY failure	Replace the touch panel ASSY.
7	Key PCB failure	Replace the panel cover ASSY.
8	Main PCB failure	Replace the main PCB ASSY.

■ **Error code E000**

Print Unable E0
Turn the power off and then back on again.

Some ROM checksum error occurred.

Error code E100

Print Unable E1
Turn the power off and then back on again.

Program error.

< User Check >

- Install the latest firmware.

Step	Cause	Remedy
1	Main PCB failure	Replace the main PCB ASSY.

■ **Error code E400**

Print Unable E4
Turn the power off and then back on again.

The failed DIMM is installed, or the DIMM is not installed correctly.

< User Check >

- Install the DIMM correctly.
- Install the latest firmware.

Step	Cause	Remedy
1	Main PCB failure	Replace the main PCB ASSY.

■ **Error code E500**

Print Unable E5
Turn the power off and then back on again.

Error occurred when DRAM on the main PCB ASSY was accessed.

Error code E600

Print Unable E6
Turn the power off and then back on again.

Error occurred during writing to EEPROM on the main PCB ASSY.

Error code E701

Print Unable E7
Turn the power off and then back on again.

Operation failure of the file system of the flash ROM on the main PCB.

Error code E702

Print Unable E7
Turn the power off and then back on again.

Error occurred during reading from the flash ROM on the main PCB.

Step	Cause	Remedy
1	Main PCB failure	Replace the main PCB ASSY.

■ **Error code E900**

Print Unable E9
Turn the power off and then back on again.

NFC PCB initialization failed.

Step	Cause	Remedy
1	Connection failure of the NFC PCB flat cable	Reconnect the NFC PCB flat cable.
2	Connection failure of the panel PCB harness	Reconnect the panel PCB harness.
3	Panel PCB failure	Replace the panel PCB unit.
4	NFC PCB failure	Replace the NFC PCB ASSY.
5	Main PCB failure	Replace the main PCB ASSY.

■ **Error code EC00**

Unusable Device
Remove the Device. Turn the power off and back on again.

Overcurrent was caused because a USB device that did not meet the specifications was inserted into the USB port.

< **User Check** >

- Remove the USB device from the USB port and turn the power OFF. Turn it ON again after a while.
- Replace the USB device with another one.

Step	Cause	Remedy
1	USB host relay PCB failure	Replace the joint cover USB ASSY.
2	Main PCB failure	Replace the main PCB ASSY.

■ **Error code F900**

-
-

Setting by spec code is not entered.

Step	Cause	Remedy
1	During function code 74, power is turned OFF.	Enter the Setting by spec code again. (Refer to "1.3.30 Setting by country (Function code 74)" in Chapter 5.)
2	Main PCB failure	Replace the main PCB ASSY.

4.2 Troubleshooting for Paper Feeding Problems

Problems related to paper feeding are end user recoverable if following the User Check items. If the same problem occurs again, follow each procedure in the order of the number described in the Step column in the tables below.

4.2.1 No paper feeding from paper tray 1

< User Check >

- Check if the paper is loaded into the paper tray correctly.
- Check that too much paper is not loaded in the paper tray.
- Turn back the paper loaded in the paper tray or change the orientation of the paper by 180°.
- Check if the thickness of the paper is 60 to 105 g/m².
- Check whether the MP tray or T2 paper tray unit is specified for the paper feeding tray.
- Fan the stack of paper well and reinsert the papers into the paper tray.
- When the T2 paper tray unit is available, check if the T2 paper tray unit is closed correctly.
- Clean the T1 paper pick-up roller.

Step	Cause	Remedy
1	T1 paper feed actuator coming off	Re-assemble the T1 paper feed actuator.
2	Connection failure of the main motor harness	Reconnect the main motor harness.
3	T1 roller holder ASSY installation failure	Install the T1 roller holder ASSY correctly.
4	Connection failure of the T1 paper feed sensor PCB harness	Reconnect the T1 paper feed sensor PCB harness.
5	T1 paper pick-up roller worn out	Replace the PF kit 1.
6	T1 paper feed sensor failure	Replace the T1 paper feed sensor PCB ASSY.
7	Lift gear 46 damaged	Replace the lift gear 46.
8	Paper feed related gear damaged	Replace the main drive unit.
9	Main motor failure	Replace the process drive unit.
10	Paper feed unit failure	Replace the paper feed unit.
11	Fuser unit damaged	Replace the fuser unit.
12	Main PCB failure	Replace the main PCB ASSY.

4.2.2 No paper feeding from T2 paper tray unit

< User Check >

- Check if the paper is loaded into the paper tray correctly.
- Check that too much paper is not loaded in the paper tray.
- Turn back the paper loaded in the paper tray or change the orientation of the paper by 180°.
- Check if the thickness of the paper is 60 to 105 g/m².
- Check whether the MP tray or paper tray 1 is specified for the paper feeding tray.
- Fan the stack of paper well and reinsert the papers into the paper tray.
- Clean the T2 paper pick-up roller.
- Check whether the paper tray 1 is closed correctly.

Step	Cause	Remedy
1	T2 paper feed actuator coming off	Re-assemble the T2 paper feed actuator.
2	Connection failure of the main motor harness	Reconnect the main motor harness.
3	T2 roller holder ASSY installation failure	Install the T2 roller holder ASSY correctly.
4	Connection failure of the T2 paper feed/plate origin sensor PCB harness	Reconnect the T2 paper feed/plate origin sensor PCB harness.
5	Connection failure of the T2 registration sensor PCB harness	Reconnect the T2 registration sensor PCB harness.
6	Connection failure of the T2 relay PCB harness	Reconnect the T2 relay PCB harness.
7	T2 paper pick-up roller worn out	Replace the PF kit 2.
8	T2 relay PCB failure	Replace the T2 relay PCB ASSY.
9	Main motor failure	Replace the process drive unit.
10	Paper feed related gear damaged	Replace the main drive unit.
11	Fuser unit damaged	Replace the fuser unit.
12	Main PCB failure	Replace the main PCB ASSY.
13	T2 connector or T2 plate motor failure	Replace the T2 paper tray unit.

4.2.3 No paper feeding from MP tray

< User Check >

- Check if the paper is loaded all the way into the MP tray.
- Check that too much paper is not loaded in the MP tray.
- Check if the machine is used with the MP tray support and MP flap are in closed state.
- Check if the thickness of the paper is 60 to 163 g/m².
- Check whether the paper tray 1 or T2 paper tray unit is specified for the paper feeding tray.
- Fan the stack of paper well and reinsert the papers into the MP tray.
- Clean the MP paper pick-up roller.
- Check whether the paper tray 1 is closed correctly.

Step	Cause	Remedy
1	MP paper empty acuator A ASSY/B coming off	Re-assemble the MP paper empty acuator A ASSY/B.
2	Connection failure of the main motor harness	Reconnect the main motor harness.
3	MP roller holder ASSY installation failure	Check the installation of the MP roller holder ASSY and install it correctly.
4	Connection failure of the MP paper empty/registration front sensor PCB harness	Reconnect the MP paper empty/registration front sensor PCB harness.
5	MP paper pick-up roller worn out	Replace the PF kit MP.
6	MP paper empty acuator A ASSY/B failure	Replace the MP paper empty acuator A ASSY/B.
7	MP paper empty/registration front sensor failure	Replace the MP paper empty/registration front sensor PCB ASSY.
8	Main motor failure	Replace the process drive unit.
9	Paper feed related gear damaged	Replace the main drive unit.
10	Fuser unit damaged	Replace the fuser unit.
11	Main PCB failure	Replace the main PCB ASSY.

4.2.4 Multiple sheets of paper are fed

< User Check >

- Check that too much paper is not loaded in any paper tray.
- Check if the paper is loaded into each paper tray correctly.
- Turn back the paper loaded in each paper tray or change the orientation of the paper by 180°.
- Check if the thickness of each paper is 60 to 105 g/m². (60 to 163 g/m² for MP tray.)
- Fan the stack of paper well and reinsert the papers into each paper tray.

Step	Cause	Remedy
1	Separation pad worn out	Replace the appropriate PF kit.

4.2.5 Paper becomes wrinkled

< User Check >

- Check if the paper is loaded into each paper tray correctly.
- Turn back the paper loaded in each paper tray or change the orientation of the paper by 180°.
- Adjust the paper guide corresponding to the paper size.
- Check if the thickness of the paper is 60 to 105 g/m². (60 to 163 g/m² for MP tray.)
- Check if paper is not damp.
- Check that no dust adheres to the fuser unit.
- Check whether the paper type is appropriate.

Step	Cause	Remedy
1	Paper eject ASSY failure	Replace the paper eject ASSY.
2	Fuser unit failure	Replace the fuser unit.

4.2.6 Paper is fed at an angle

< User Check >

- Check if the paper is loaded into each paper tray correctly.
- Turn back the paper loaded in each paper tray or change the orientation of the paper by 180°.
- Adjust the paper guide corresponding to the paper size.
- Check if the thickness of the paper is 60 to 105 g/m². (60 to 163 g/m² for MP tray.)
- Check that too much paper is not loaded in the paper tray.
- Check whether the paper type is appropriate.
- Clean each paper pick-up roller.
- Check if only the one side of the envelope lever is lowered.

Step	Cause	Remedy
1	Uneven worn-out of each paper pick-up roller	Replace the appropriate PF kit.
2	Paper feed unit failure	Replace the paper feed unit.
3	Main PCB failure	Replace the main PCB ASSY.

4.2.7 Paper curls

< User Check >

- Check if the size of paper specified from the driver is matched with the one actually loaded.
- Select "Reduce Paper Curl" in the driver.
- Check if the paper is loaded into each paper tray correctly.
- Print with the envelope lever is lowered.

Step	Cause	Remedy
1	Fuser unit failure	Replace the fuser unit.
2	Main PCB failure	Replace the main PCB ASSY.

4.2.8 Unable to perform 2-sided printing

< User Check >

- Firmly close the back cover.
- Firmly set the paper tray.
- Set the driver setting to 2-sided printing.
- Use the paper equal to or larger than Letter size or A4 size.
(Use paper specified in each country setting.)

Step	Cause	Remedy
1	Eject actuator coming off	Re-assemble the eject actuator.
2	Back cover failure	Replace the back cover.
3	Eject sensor failure	Replace the eject sensor PCB ASSY.
4	Paper eject origin sensor failure	Replace the paper eject origin sensor.
5	Paper eject ASSY failure	Replace the paper eject ASSY.
6	Main PCB failure	Replace the main PCB ASSY.

4.2.9 Paper jam

■ Paper jam at the paper tray 1

< User Check >

- Check if the paper is loaded into the paper tray 1 correctly.
- Turn back the paper loaded in the paper tray 1 or change the orientation of the paper by 180°.
- Adjust the paper guide corresponding to the paper size.
- Check if too much paper is loaded in the tray.
- Check if the thickness of the paper is 60 to 105 g/m².
- Fan the stack of paper well and reinsert the papers into the paper tray.
- Replace the toner cartridge with a new one.
- Replace the drum unit with a new one.

Step	Cause	Remedy
1	Foreign object around paper tray 1	Remove the foreign object.
2	T1 paper dust cleaning roller installation failure	Re-assemble the T1 paper dust cleaning roller.
3	Registration front actuator coming off	Re-assemble the registration front actuator.
4	Connection failure of the registration front/rear sensor PCB harness	Reconnect the registration front/rear sensor PCB harness.
5	Registration front sensor failure	Replace the registration front/rear sensor PCB ASSY.
6	Fuser drive gear Z25 damaged	Replace the fuser drive gear Z25.
7	Main motor failure	Replace the process drive unit.
8	Paper feed related gear damaged	Replace the main drive unit.
9	Paper feed unit failure	Replace the paper feed unit.
10	Fuser unit damaged	Replace the fuser unit.
11	Main PCB failure	Replace the main PCB ASSY.

■ Paper jam at the T2 paper tray unit

< User Check >

- Check if the paper is loaded into the T2 paper tray unit correctly.
- Turn back the paper loaded in the T2 paper tray unit or change the orientation of the paper by 180°.
- Adjust the paper guide corresponding to the paper size.
- Check if too much paper is loaded in the tray.
- Check if the thickness of the paper is 60 to 105 g/m².
- Fan the stack of paper well and reinsert the papers into the paper tray.
- Replace the toner cartridge with a new one.
- Replace the drum unit with a new one.

Step	Cause	Remedy
1	Foreign object around T2 paper tray unit	Remove the foreign object.
2	Foreign object around paper path of paper tray 1	Remove the foreign object.
3	T1/T2 paper dust cleaning roller installation failure	Re-assemble the T1/T2 paper dust cleaning roller.
4	Registration front actuator coming off	Re-assemble the registration front actuator.
5	Connection failure of the registration front/rear sensor PCB harness	Reconnect the registration front/rear sensor PCB harness.
6	Connection failure of the T2 registration sensor PCB harness	Reconnect the T2 registration sensor PCB harness.
7	Connection failure of the T2 relay PCB harness	Reconnect the T2 relay PCB harness.
8	T2 relay PCB failure	Replace the T2 relay PCB ASSY.
9	Fuser drive gear Z25 damaged	Replace the fuser drive gear Z25.
10	Main motor failure	Replace the process drive unit.
11	Paper feed unit failure	Replace the paper feed unit.
12	Fuser unit damaged	Replace the fuser unit.
13	Main PCB failure	Replace the main PCB ASSY.

■ Paper jam at the MP tray

< User Check >

- Check if the paper is loaded into the MP tray correctly.
- Turn back the paper loaded in the MP tray or change the orientation of the paper by 180°.
- Adjust the paper guide corresponding to the paper size.
- Check if too much paper is loaded in the tray.
- Check if the thickness of the paper is 60 to 163 g/m².
- Fan the stack of paper well and reinsert the papers into the paper tray.

Step	Cause	Remedy
1	Foreign object around MP tray	Remove the foreign object.
2	MP registration front actuator coming off	Re-assemble the MP registration front actuator.
3	Connection failure of the MP registration front sensor PCB harness	Reconnect the MP registration front sensor PCB harness.
4	MP paper empty/registration front sensor failure	Replace the MP paper empty/registration front sensor PCB ASSY.
5	Main motor failure	Replace the process drive unit.
6	Paper feed unit failure	Replace the paper feed unit.
7	Fuser unit damaged	Replace the fuser unit.
8	Main PCB failure	Replace the main PCB ASSY.

■ Paper jam at the paper feeding section at the center of the machine

< User Check >

- Check if the paper is loaded into each paper tray correctly.
- Turn back the paper loaded in each paper tray or change the orientation of the paper by 180°.
- Adjust each paper guide in accordance with the paper size.
- Check if too much paper is loaded in the tray.
- Check if the thickness of the paper is 60 to 105 g/m².
- Fan the stack of paper well and reinsert the papers into each paper tray.
- Check that the belt unit is properly set.
- Replace the drum unit.
- Replace the belt unit.

Step	Cause	Remedy
1	Foreign object inside machine	Remove the foreign object.
2	Eject actuator coming off	Re-assemble the eject actuator.
3	Fuser cover installation failure	Re-assemble the fuser cover.
4	Connection failure of the eject sensor PCB harness	Reconnect the eject sensor PCB harness.
5	Eject sensor failure	Replace the eject sensor PCB ASSY.
6	Fuser drive gear Z25 damaged	Replace the fuser drive gear Z25.
7	Main motor or process motor failure	Replace the process drive unit.
8	Fuser unit failure	Replace the fuser unit.
9	Main PCB failure	Replace the main PCB ASSY.

■ Paper jam at the eject section

< User Check >

- Check if the paper is loaded into each paper tray correctly.
- Turn back the paper loaded in each paper tray or change the orientation of the paper by 180°.
- Adjust each paper guide in accordance with the paper size.
- Check if too much paper is loaded in the tray.
- Check if the thickness of the paper is 60 to 105 g/m².
- Fan the stack of paper well and reinsert the papers into each paper tray.

Step	Cause	Remedy
1	Foreign object in back cover section	Remove the foreign object.
2	Eject actuator coming off	Re-assemble the eject actuator.
3	Fuser cover installation failure	Re-assemble the fuser cover.
4	Connection failure of the eject sensor PCB harness	Reconnect the eject sensor PCB harness.
5	Eject sensor failure	Replace the eject sensor PCB ASSY.
6	Paper eject origin sensor failure	Replace the paper eject origin sensor.
7	Main motor or process motor failure	Replace the process drive unit.
8	Paper eject ASSY failure	Replace the paper eject ASSY.
9	Fuser unit failure	Replace the fuser unit.
10	Main PCB failure	Replace the main PCB ASSY.

■ Paper jam at the duplex tray

< User Check >

- Turn back the paper loaded in each paper tray or change the orientation of the paper by 180°.
- Check if the thickness of the paper is 60 to 105 g/m².
- Fan the stack of paper well and reinsert the papers into each paper tray.

Step	Cause	Remedy
1	Foreign object in duplex path	Remove the foreign object.
2	Eject actuator coming off	Re-assemble the eject actuator.
3	Fuser cover installation failure	Re-assemble the fuser cover.
4	Back cover failure	Replace the back cover.
5	Duplex tray failure	Replace the duplex tray.
6	Failure of duplex path of paper tray 1	Replace the paper tray 1.
7	Main PCB failure	Replace the main PCB ASSY.

4.3 Troubleshooting for Image Defects

4.3.1 Image defect examples

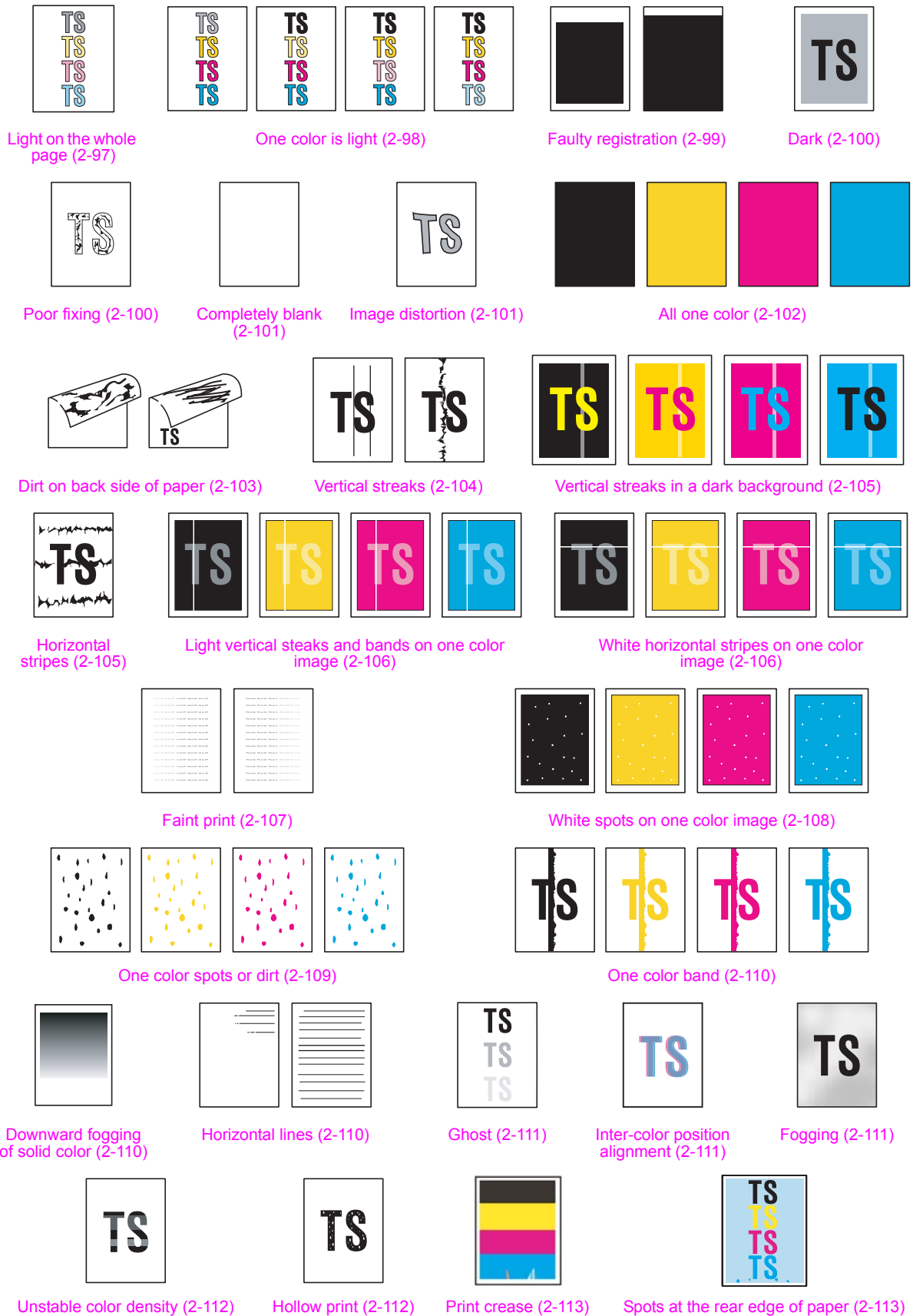

Fig. 2-9

4.3.2 Troubleshooting image defect

Image defect related problems are end user recoverable if following the User Check items. If the same problem occurs again, follow each procedure in the order of the number described in the Step column in the tables below.

■ Light on the whole page



< User Check >

- Check the machine's environment. High temperature and high humidity or low temperature and low humidity conditions can cause this problem.
- If the whole page is light, toner save mode may be ON. Turn OFF the toner save mode.
- Adjust the color calibration from the control panel.
- Replace the drum unit with a new one.
- Replace the toner cartridge with a new one.
- Replace the belt unit with a new one.
- Wipe the scanner windows of the laser unit with a soft, lint-free cloth.
- Leave the machine for a while as the power remains ON.
(Condensation)
- Check if paper is not damp.

Step	Cause	Remedy
1	Dirt on the electrodes of the main body and the drum unit	Clean the electrodes of the main body and the drum unit. (Refer to Fig. 2-7 (P2-55), Fig. 2-8 (P2-55).)
2	Dirt on the electrodes of the high-voltage power supply PCB	Clean the electrodes of the high-voltage power supply PCB.
3	Dirt on the density sensor	Clean the density sensor.
4	Density sensor failure	Replace the registration mark sensor unit.
5	Fuser unit failure	Replace the fuser unit.
6	High-voltage power supply PCB failure	Replace the high-voltage power supply PCB ASSY.
7	Main PCB failure	Replace the main PCB ASSY.

■ One color is light

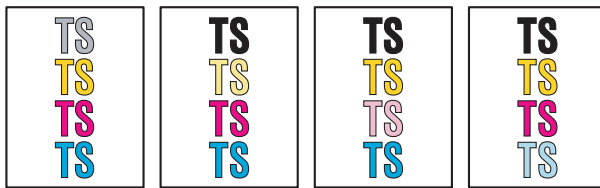

< User Check >

- Check the machine's environment. High temperature and high humidity or low temperature and low humidity conditions can cause this problem.
- Adjust the color calibration from the control panel.
- Replace the drum unit with a new one.
- Replace the toner cartridge with a new one.
- Wipe the scanner windows of the laser unit of the appropriate color with a soft, lint-free cloth.

Step	Cause	Remedy
1	Dirt on the electrodes of the main body and the drum unit	Clean the electrodes of the main body and the drum unit. (Refer to Fig. 2-7 (P2-55), Fig. 2-8 (P2-55).)
2	Dirt on the electrodes of the main body and the toner cartridge	Clean the electrodes of the main body and the toner cartridge. (Refer to Fig. 2-7 (P2-55), See the figure below.)
3	Dirt on the electrodes of the main body and the belt unit	Clean the electrodes of the main body and the belt unit. (Refer to Fig. 2-7 (P2-55), Fig. 2-11 (P2-99).)
4	Dirt on the electrodes of the high-voltage power supply PCB	Clean the electrodes of the high-voltage power supply PCB.
5	Density sensor failure	Replace the registration mark sensor unit.
6	Fuser unit failure	Replace the fuser unit.
7	High-voltage power supply PCB failure	Replace the high-voltage power supply PCB ASSY.
8	Main PCB failure	Replace the main PCB ASSY.

■ Electrodes location of the toner cartridge

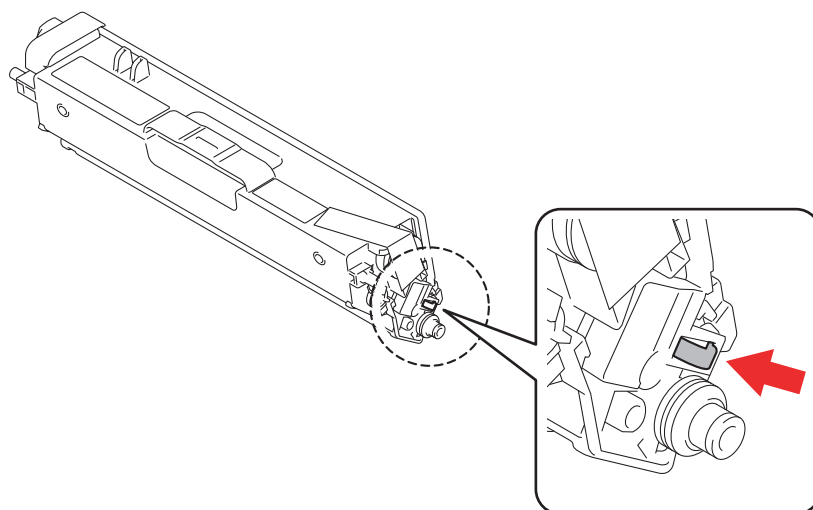

Fig. 2-10

■ Electrodes location of belt unit

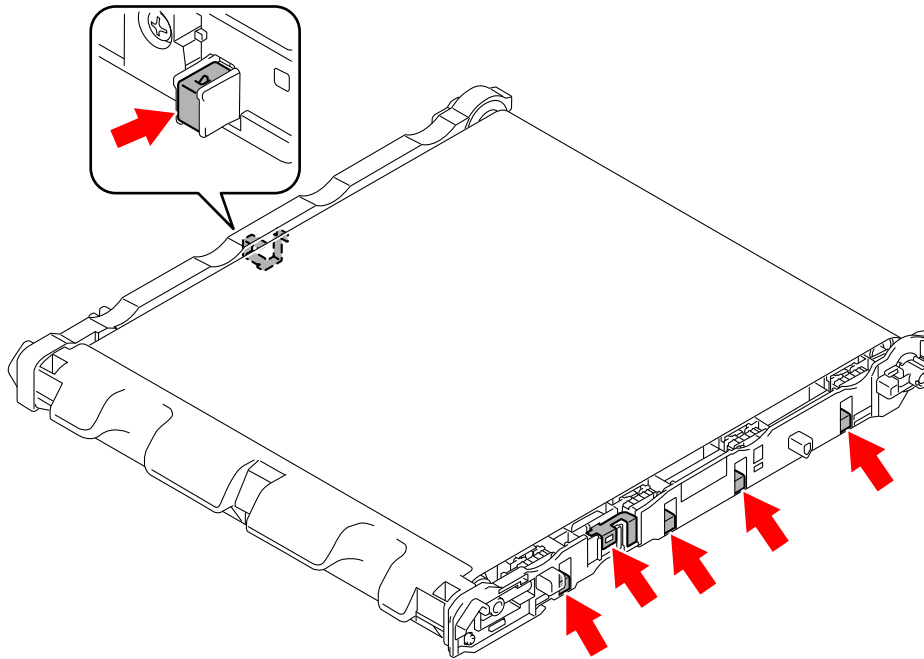
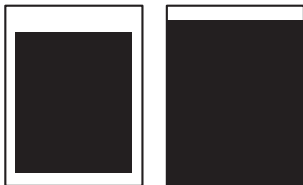

Fig. 2-11

■ Faulty registration



< User Check >

- Check whether appropriate paper type is selected on the driver.

Step	Cause	Remedy
1	Registration rear actuator coming off	Re-assemble the registration rear actuator.
2	Laser unit failure	Replace the laser unit.
3	Main PCB failure	Replace the main PCB ASSY.

■ Dark



< User Check >

- Check the machine's environment. High temperature and high humidity or low temperature and low humidity conditions can cause this problem.
- After a new toner cartridge is detected, check if other toner cartridge is not inserted.
- Execute density adjustment from the control panel.
- Clean the corona wire of all four colors on the drum unit.
- Replace the drum unit with a new one.
- Replace the toner cartridge with a new one.
- Replace the belt unit with a new one.

Step	Cause	Remedy
1	Dirt on the electrodes of the main body and the drum unit	Clean the electrodes of the main body and the drum unit. (Refer to Fig. 2-7 (P2-55), Fig. 2-8 (P2-55).)
2	Dirt on the electrodes of the main body and the toner cartridge	Clean the electrodes of the main body and the toner cartridge. (Refer to Fig. 2-7 (P2-55), Fig. 2-10 (P2-98).)
3	Dirt on the electrodes of the main body and the belt unit	Clean the electrodes of the main body and the belt unit. (Refer to Fig. 2-7 (P2-55), Fig. 2-11 (P2-99).)
4	Dirt on the electrodes of the high-voltage power supply PCB	Clean the electrodes of the high-voltage power supply PCB.
5	Density sensor failure	Replace the registration mark sensor unit.
6	Fuser unit failure	Replace the fuser unit.
7	High-voltage power supply PCB failure	Replace the high-voltage power supply PCB ASSY.
8	Main PCB failure	Replace the main PCB ASSY.
9	Laser unit failure	Replace the laser unit.

■ Poor fixing

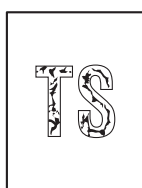

< User Check >

- Check the machine's environment. High temperature and high humidity or low temperature and low humidity conditions can cause this problem.
- Clean the corona wire of all four colors on the drum unit.
- Replace the drum unit with a new one.
- Replace the toner cartridge with a new one.
- Replace the belt unit with a new one.
- Wipe the scanner windows of the laser unit with a soft, lint-free cloth.

Step	Cause	Remedy
1	Dirt on the electrodes of the main body and the belt unit	Clean the electrodes of the main body and the belt unit. (Refer to Fig. 2-7 (P2-55), Fig. 2-11 (P2-99).)
2	Fuser unit failure	Replace the fuser unit.
3	High-voltage power supply PCB failure	Replace the high-voltage power supply PCB ASSY.
4	Low-voltage power supply PCB failure	Replace the low-voltage power supply PCB unit.
5	Laser unit failure	Replace the laser unit.
6	Main PCB failure	Replace the main PCB ASSY.

■ Completely blank

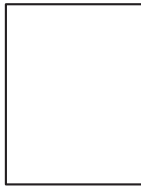

< User Check >

- Clean the corona wire of all four colors on the drum unit.
- Replace the drum unit with a new one.
- Replace the toner cartridge with a new one.
- Install the latest firmware.

Step	Cause	Remedy
1	Dirt on the electrodes of the main body and the drum unit	Clean the electrodes of the main body and the drum unit. (Refer to Fig. 2-7 (P2-55), Fig. 2-8 (P2-55).)
2	Dirt on the electrodes of the main body and the toner cartridge	Clean the electrodes of the main body and the toner cartridge. (Refer to Fig. 2-7 (P2-55), Fig. 2-10 (P2-98).)
3	Dirt on the electrodes of the main body and the belt unit	Clean the electrodes of the main body and the belt unit. (Refer to Fig. 2-7 (P2-55), Fig. 2-11 (P2-99).)
4	Connection failure of the laser unit flat cable	Reconnect the laser unit flat cable.
5	Laser unit flat cable failure	Replace the laser unit flat cable.
6	Dirt on the electrodes of the high-voltage power supply PCB	Clean the electrodes of the high-voltage power supply PCB.
7	Laser unit failure	Replace the laser unit.
8	Main PCB failure	Replace the main PCB ASSY.

■ Image distortion



< User Check >

- Replace the belt unit with a new one.

Step	Cause	Remedy
1	Laser unit installation failure	Re-assemble the laser unit.
2	Laser unit failure	Replace the laser unit.
3	Main PCB failure	Replace the main PCB ASSY.

■ All one color

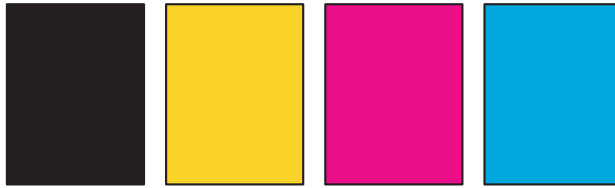

< User Check >

- Clean the corona wire of all four colors on the drum unit.
- Replace the drum unit with a new one.

Step	Cause	Remedy
1	Dirt on the electrodes of the main body and the drum unit	Clean the electrodes of the main body and the drum unit. (Refer to Fig. 2-7 (P2-55), Fig. 2-8 (P2-55).)
2	Dirt on the electrodes of the main body and the toner cartridge	Clean the electrodes of the main body and the toner cartridge. (Refer to Fig. 2-7 (P2-55), Fig. 2-10 (P2-98).)
3	Dirt on the electrodes of the main body and the belt unit	Clean the electrodes of the main body and the belt unit. (Refer to Fig. 2-7 (P2-55), Fig. 2-11 (P2-99).)
4	Laser unit flat cable failure	Replace the laser unit flat cable.
5	High-voltage power supply PCB failure	Replace the high-voltage power supply PCB ASSY.
6	Laser unit failure	Replace the laser unit.
7	Main PCB failure	Replace the main PCB ASSY.

■ **Dirt on back side of paper**

< **User Check** >

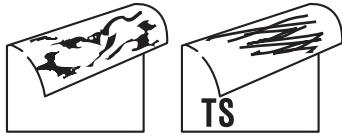

- This symptom might stop occurring after making several prints.
- Replace the toner cartridge with a new one.
- Replace the belt unit.
- Replace the waste toner box.

Step	Cause	Remedy
1	Dirt in the paper feed system	Wipe dirt off.
2	Dirt on the electrodes of the main body and the belt unit	Clean the electrodes of the main body and the belt unit. (Refer to Fig. 2-7 (P2-55), Fig. 2-11 (P2-99).)
3	Dirt on the electrodes of the main body and the waste toner box	Clean the electrodes of the main body and the waste toner box. (Refer to Fig. 2-7 (P2-55), See the figure below.)
4	Dirt on the cleaner pinch roller of the fuser cover	Replace the cleaner pinch roller S ASSY.
5	Dirt on the fuser unit	Replace the fuser unit.
6	High-voltage power supply PCB failure	Replace the high-voltage power supply PCB ASSY.

■ **Electrodes location of waste toner box**

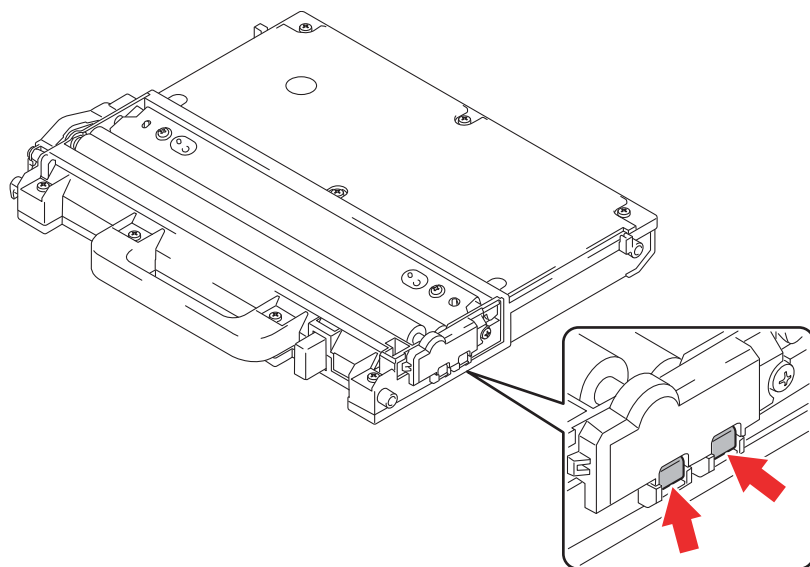
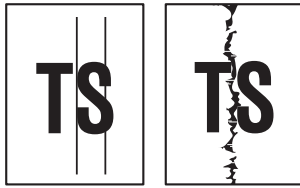

Fig. 2-12

■ Vertical streaks



< User Check >

- Clean the corona wire of all four colors on the drum unit.
- Return the cleaning tab of the corona wire to the ▲ position.
- This symptom might stop occurring after making several prints.
- Refer to the User's guide and remove the dirt on the exposure drum using a cotton swab.
- Replace the drum unit with a new one.
- Replace the toner cartridge with a new one.
- Wipe the scanner windows of the laser unit with a soft, lint-free cloth.

Step	Cause	Remedy
1	Dirt in the paper feed system	Wipe dirt off.
2	Installation failure of each FG wire and/or FG plate (Grounding is not performed correctly.)	Retighten the screws of each FG wire and/or FG plate. Repair the bend of the tray ground spring of the paper tray. (See the figure below.)
3	Dirt on the exposure drum	Perform drum cleaning. (Refer to "2.2 Drum Cleaning" in Chapter 5.)
4	Dirt on the cleaner pinch roller of the fuser cover	Replace the cleaner pinch roller S ASSY.
5	Dirt on the fuser unit	Replace the fuser unit.
6	Laser unit failure	Replace the laser unit.

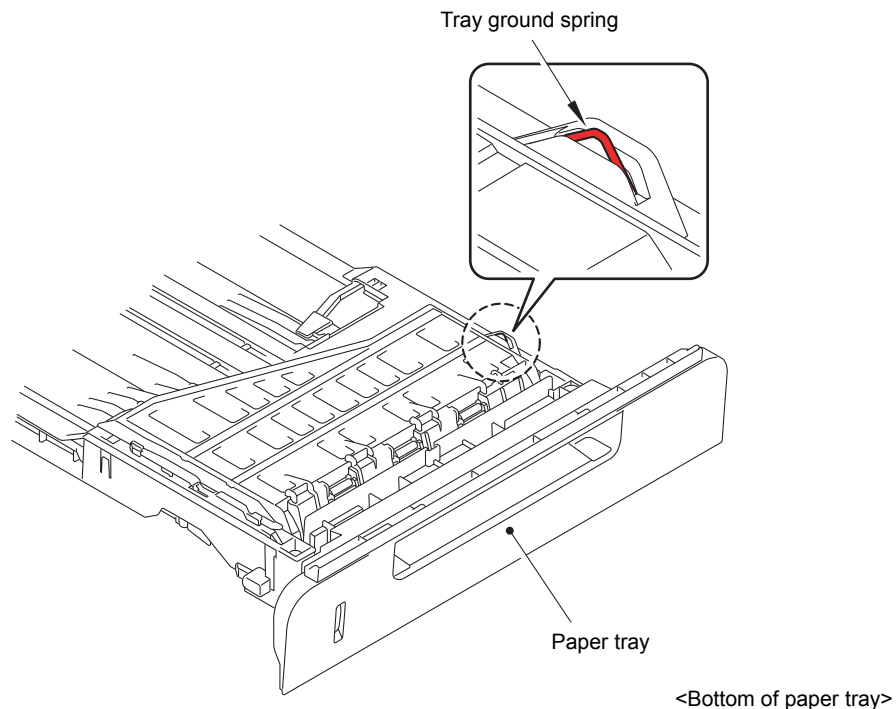
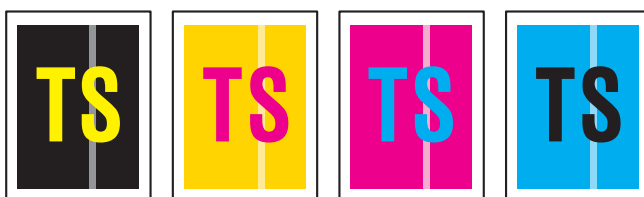

Fig. 2-13

■ **Vertical streaks in a dark background**



< **User Check** >

- Clean the corona wire of all four colors on the drum unit.
- This symptom might stop occurring after making several prints.
- Refer to the User's guide and remove the dirt on the exposure drum using a cotton swab.
- Leave the machine for a while as the power remains ON. (Condensation)
- Wipe the scanner windows of the laser unit with a soft, lint-free cloth.
- Replace the drum unit with a new one.
- Replace the toner cartridge with a new one.

Step	Cause	Remedy
1	Dirt on charged electrode	Clean the electrodes of the drum unit and the main body. (Refer to Fig. 2-8 (P2-55), Fig. 2-7 (P2-55).)
2	Dirt on the exposure drum	Perform drum cleaning. (Refer to "2.2 Drum Cleaning" in Chapter 5.)
3	Laser unit failure	Replace the laser unit.

■ **Horizontal stripes**



< **User Check** >

- Clean the corona wire of all four colors on the drum unit.
- This symptom might stop occurring after making several prints.
- Refer to the User's guide and remove the dirt on the exposure drum using a cotton swab.
- Replace the drum unit with a new one.
- Replace the toner cartridge with a new one.

Step	Cause	Remedy
1	Dirt on charged electrode	Clean the electrodes of the drum unit and the main body. (Refer to Fig. 2-8 (P2-55), Fig. 2-7 (P2-55).)
2	Dirt on the exposure drum	Perform drum cleaning. (Refer to "2.2 Drum Cleaning" in Chapter 5.)
3	Installation failure of each FG wire and/or FG plate (Grounding is not performed correctly.)	Retighten the screws of each FG wire and/or FG plate. Repair the bend of the tray ground spring of the paper tray. (Refer to Fig. 2-13 (P2-104).)
4	Scratch and dirt on fuser unit	Replace the fuser unit.
5	High-voltage power supply PCB failure	Replace the high-voltage power supply PCB ASSY.

■ **Light vertical streaks and bands on one color image**



< User Check >

- Clean the corona wire of all four colors on the drum unit.
- Check if dust adheres to the area of the toner cartridge corresponding to the location where the white vertical streak appears.
- Refer to the User's guide and remove the dirt on the exposure drum using a cotton swab.
- Wipe the scanner windows of the laser unit with a soft, lint-free cloth.
- Replace the drum unit with a new one.
- Replace the toner cartridge with a new one.

Step	Cause	Remedy
1	Dirt on charged electrode	Clean the electrodes of the drum unit and the main body. (Refer to Fig. 2-8 (P2-55), Fig. 2-7 (P2-55).)
2	Dirt on the exposure drum	Perform drum cleaning. (Refer to "2.2 Drum Cleaning" in Chapter 5.)
3	Laser unit failure	Replace the laser unit.

■ **White horizontal stripes on one color image**

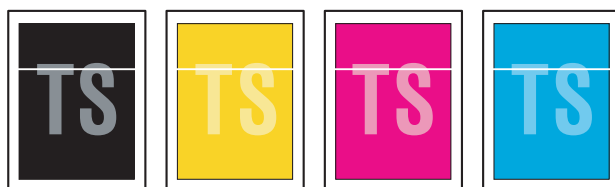

< User Check >

- This symptom might stop occurring after making several prints.
- Replace the drum unit with a new one.
- Replace the toner cartridge with a new one.

Step	Cause	Remedy
1	Dirt on charged electrode	Clean the electrodes of the drum unit and the main body. (Refer to Fig. 2-8 (P2-55), Fig. 2-7 (P2-55).)
2	Dirt on the exposure drum	Perform drum cleaning. (Refer to "2.2 Drum Cleaning" in Chapter 5.)
3	Scratch and dirt on fuser unit	Replace the fuser unit.
4	High-voltage power supply PCB failure	Replace the high-voltage power supply PCB ASSY.

■ Faint print

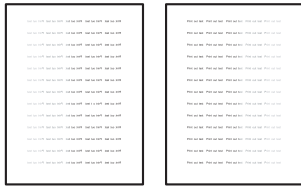

< User Check >

- Check that the machine is set on a level surface.
- Wipe the scanner windows of the laser unit with a soft, lint-free cloth.
- Replace the drum unit with a new one.
- Replace the toner cartridge with a new one.

Step	Cause	Remedy
1	Laser unit failure	Replace the laser unit.
2	Fuser unit failure	Replace the fuser unit.
3	Main PCB failure	Replace the main PCB ASSY.

■ White spots on one color image

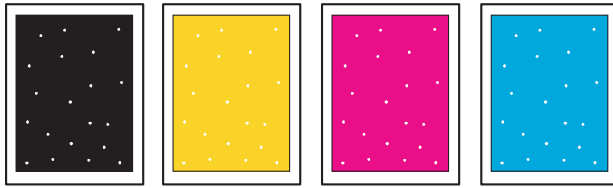

< User Check >

- Check if the fuser fan and/or blower are not blocked.
- Refer to the User's guide and remove the dirt on the exposure drum using a cotton swab.
- Replace the drum unit with a new one.
- Replace the toner cartridge with a new one.
- Replace the belt unit with a new one.

Step	Cause	Remedy
1	Paper dust is accumulated	Referring to the figure below, remove paper dust attached on the paper dust cleaning roller.
2	Dirt on the exposure drum	Perform drum cleaning. (Refer to "2.2 Drum Cleaning" in Chapter 5.)
3	Toner filter is clogged	Clean the toner filter.
4	Scratch and dirt on fuser unit	Replace the fuser unit.
5	High-voltage power supply PCB failure	Replace the high-voltage power supply PCB ASSY.

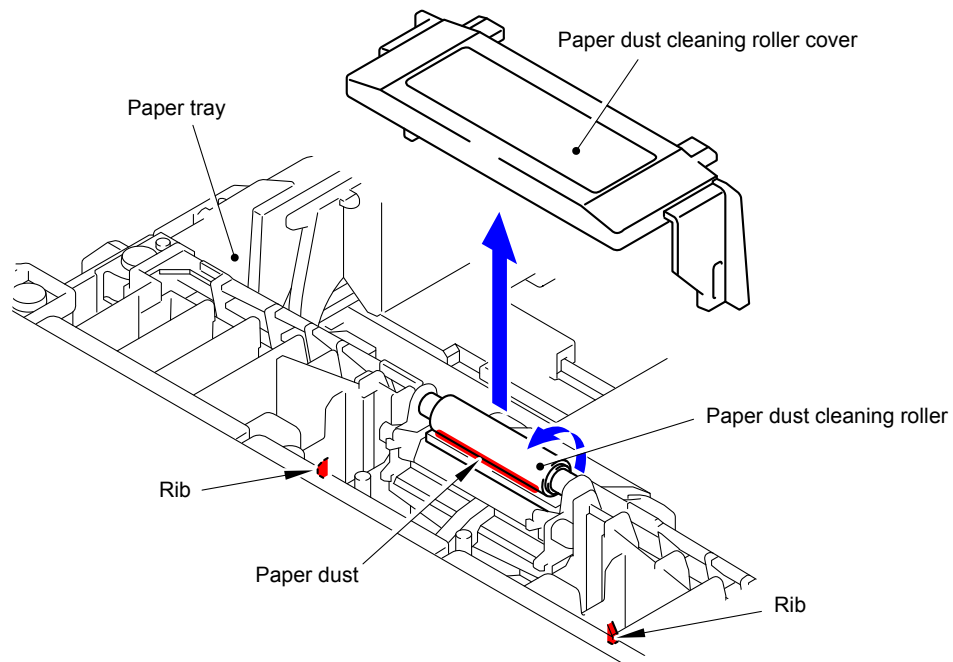
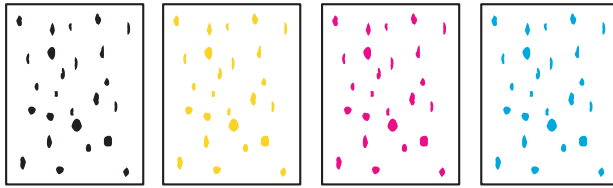

Fig. 2-14

■ **One color spots or dirt**



< **User Check** >

- Check if damp paper is used.
- Refer to the User's guide and remove the dirt on the exposure drum using a cotton swab.
- Replace the drum unit with a new one.
- Replace the toner cartridge with a new one.
- Replace the belt unit with a new one.

Step	Cause	Remedy
1	Paper dust is accumulated	Clean the paper dust cleaning roller. (Refer to Fig. 2-14 (P2-108).)
2	Dirt on the exposure drum	Perform drum cleaning. (Refer to "2.2 Drum Cleaning" in Chapter 5.)
3	Toner filter is clogged	Clean the toner filter.
4	Scratch and dirt on fuser unit	Replace the fuser unit.
5	High-voltage power supply PCB failure	Replace the high-voltage power supply PCB ASSY.

Note:

Image defects which occur periodically may be caused by a failure of the rollers. Use the diameters of the rollers or the pitches which appear in images shown in the table below to identify the cause of the problem.

<Pitches on images caused by rollers>

Part name	The pitch which appears in the image
Develop roller	30 mm
Exposure drum	94 mm
Heat roller of the fuser unit	78.5 mm
Pressure roller of the fuser unit	78.5 mm

■ **One color band**



< **User Check** >

- Clean the corona wire of all four colors on the drum unit.
- Return the cleaning tab of the corona wire to the ▲ position.
- This symptom might stop occurring after making several prints.
- Refer to the User's guide and remove the dirt on the exposure drum using a cotton swab.
- Replace the drum unit with a new one.
- Replace the toner cartridge with a new one.

Step	Cause	Remedy
1	Installation failure of each FG wire and/or FG plate (Grounding is not performed correctly.)	Retighten the screws of each FG wire and/or FG plate. Repair the bend of the tray ground spring of the paper tray. (Refer to Fig. 2-13 (P2-104).)
2	Dirt on the exposure drum	Perform drum cleaning. (Refer to "2.2 Drum Cleaning" in Chapter 5.)
3	Laser unit failure	Replace the laser unit.

■ **Downward fogging of solid color**



< **User Check** >

- Replace the toner cartridge with a new one.

Step	Cause	Remedy
1	High-voltage power supply PCB failure	Replace the high-voltage power supply PCB ASSY.
2	Main PCB failure	Replace the main PCB ASSY.

■ **Horizontal lines**

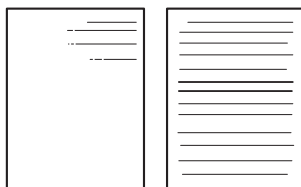

< **User Check** >

- This symptom might stop occurring after making several prints.
- Refer to the User's guide and remove the dirt on the exposure drum using a cotton swab.
- Replace the drum unit with a new one.
- Replace the toner cartridge with a new one.

Step	Cause	Remedy
1	Dirt on charged electrode	Clean the electrodes of the drum unit and main body. (Refer to Fig. 2-8 (P2-55), Fig. 2-7 (P2-55).)
2	Dirt on the exposure drum	Perform drum cleaning. (Refer to "2.2 Drum Cleaning" in Chapter 5.)
3	Scratch and dirt on fuser unit	Replace the fuser unit.
4	High-voltage power supply PCB failure	Replace the high-voltage power supply PCB ASSY.

■ Ghost



< User Check >

- Check the machine's environment. High temperature and high humidity or low temperature and low humidity conditions can cause this problem.
- Check whether appropriate paper type is selected on the driver.
- Select "Improve Toner Fixing Mode" in the driver.
- Make a print in the color mode.
- Replace the drum unit with a new one.

Step	Cause	Remedy
1	Scratch and dirt on fuser unit	Replace the fuser unit.
2	High-voltage power supply PCB failure	Replace the high-voltage power supply PCB ASSY.

■ Inter-color position alignment



< User Check >

- Implement the adjustment of color registration (adjustment of inter-color position alignment).
- Replace the belt unit with a new one.
- Replace the drum unit with a new one.
- Replace the waste toner box with a new one.

Step	Cause	Remedy
1	Registration mark sensor L or registration mark sensor R failure	Replace the registration mark sensor unit.
2	Main PCB failure	Replace the main PCB ASSY.

■ Fogging



< User Check >

- Check the machine's environment. High temperature and high humidity or low temperature and low humidity conditions can cause this problem.
- Check if the acid paper is not used.
- This symptom might stop occurring after making several prints.
- Replace the toner cartridge with a new one.
- Replace the drum unit with a new one.

Step	Cause	Remedy
1	Toner/new sensor PCB failure	Replace the toner/new sensor PCB ASSY.
2	High-voltage power supply PCB failure	Replace the high-voltage power supply PCB ASSY.
3	Main PCB failure	Replace the main PCB ASSY.

Note:

This problem often occurs when the drum unit or toner cartridge is nearly at the end of life.

■ Unstable color density



< User Check >

- Make a print on a different type of paper.
- Replace the belt unit with a new one.
- Replace the waste toner box with a new one.
- Replace the toner cartridge with a new one.
- Replace the drum unit with a new one.

Step	Cause	Remedy
1	Dirt on the electrodes of the main body and the drum unit	Clean the electrodes of the main body and the drum unit. (Refer to Fig. 2-7 (P2-55), Fig. 2-8 (P2-55).)
2	Dirt on the electrodes of the main body and the toner cartridge	Clean the electrodes of the main body and the toner cartridge. (Refer to Fig. 2-7 (P2-55), Fig. 2-10 (P2-98).)
3	Dirt on the electrodes of the main body and the belt unit	Clean the electrodes of the main body and the belt unit. (Refer to Fig. 2-7 (P2-55), Fig. 2-11 (P2-99).)
4	High-voltage power supply PCB failure	Replace the high-voltage power supply PCB ASSY.
5	Laser unit failure	Replace the laser unit.
6	Main PCB failure	Replace the main PCB ASSY.

■ Hollow print



< User Check >

- Check the machine's environment. High temperature and high humidity or low temperature and low humidity conditions can cause this problem.
- Refer to the User's guide and remove the dirt on the exposure drum using a cotton swab.
- Replace the toner cartridge with a new one.
- Replace the drum unit with a new one.

Step	Cause	Remedy
1	Dirt in the paper dust cleaning roller	Clean the paper dust cleaning roller. (Refer to Fig. 2-14 (P2-108).)
2	Dirt on the exposure drum	Perform drum cleaning. (Refer to "2.2 Drum Cleaning" in Chapter 5.)
3	Scratch and dirt on fuser unit	Replace the fuser unit.
4	High-voltage power supply PCB failure	Replace the high-voltage power supply PCB ASSY.

■ **Print crease**



< **User Check** >

- Check the machine's environment. High temperature and high humidity or low temperature and low humidity conditions can cause this problem.
- Change the paper to thick paper.
- Check if paper is not damp.
- Check if the thickness of the paper is properly set in the driver.
- Print with the envelope lever is lowered. (Refer to the figure below.)

Step	Cause	Remedy
1	Fuser unit failure	Replace the fuser unit.

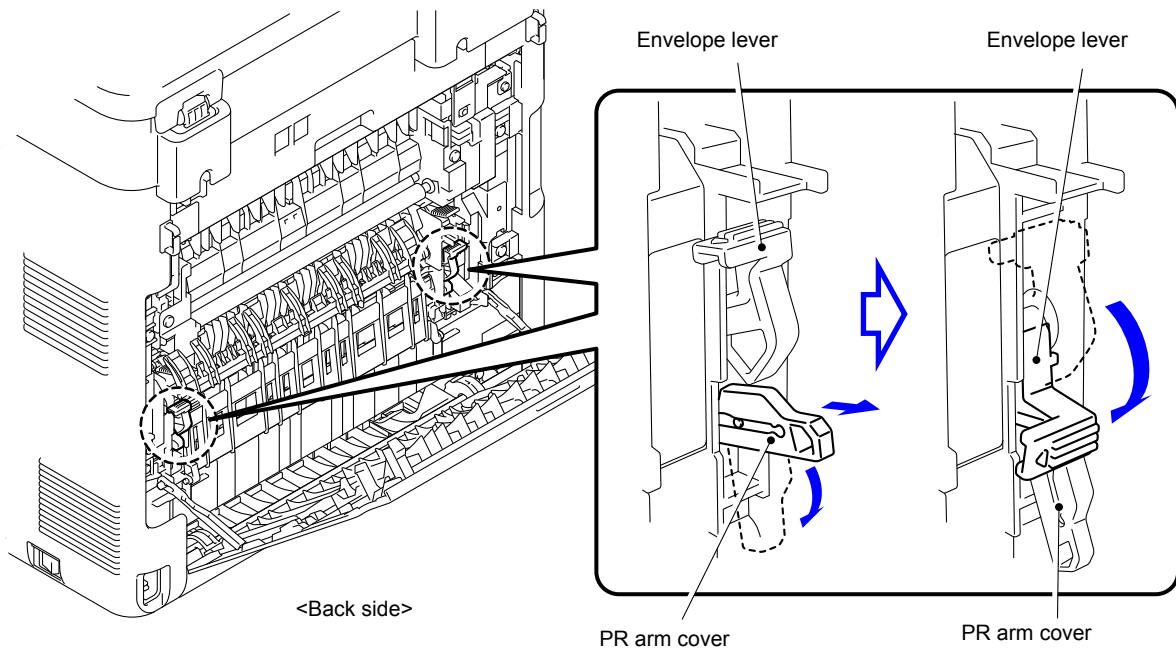

Fig. 2-15

■ **Spots at the rear edge of paper**



< **User Check** >

- Check the machine's environment. High temperature and high humidity or low temperature and low humidity conditions can cause this problem.
- Print with the envelope lever is lowered. (See the figure above.)

Step	Cause	Remedy
1	Fuser unit failure	Replace the fuser unit.

4.4 Troubleshooting for Software Problems

The end user can solve problems pertaining to software, for instance, print cannot be made from a computer although test print and printer setting print can be made from the machine, by following the User Check items. If the same problem occurs again, follow each procedure in the order of the number described in the Step column in the tables below.

4.4.1 Unable to receive data

< User Check >

- Check that the USB cable or LAN cable is not damaged.
- Check that the correct machine is selected if you have an interface switching device.
- Check the descriptions on the software setting in the User's guide.
- Check the driver setting.
- Restore the settings at factory shipment. (Refer to User's guide.)

Step	Cause	Remedy
1	Machine connection	When using Macintosh, check the product ID* in Macintosh and update the firmware if the product ID is not correct.
2	Main PCB failure	Replace the main PCB ASSY.

* Follow the procedures below to verify the product ID in Macintosh.

- (1) Select [About This Mac] from the [Apple] menu.
- (2) Click the [More Info...] button in the [About This Mac] dialog box.
- (3) Select [USB] under the [Hardware] in [Contents] on the left side.
- (4) Select the machine [DCP-XXXX or MFC-XXXX] from [USB Device Tree].
- (5) Check [Product ID] in [DCP-XXXX] or [MFC-XXXX].

■ Product ID (Hexadecimal)

DCP-L8400CDN: 030Fh

DCP-L8450CDW: 0310h

MFC-L8600CDW: 0311h

MFC-L8650CDW: 0312h

MFC-L8850CDW: 0313h

MFC-L9550CDW: 0314h

4.5 Troubleshooting for Network Problems

4.5.1 Cannot make a print through network connection

< User Check >

- Check the descriptions in the network User's guide.
- Check the network connection.
- Perform network reset. (Refer to User's guide.)
- Check the LAN cable.

Step	Cause	Remedy
1	Connection failure of the wireless LAN PCB harness	Reconnect the wireless LAN PCB harness.
2	Wireless LAN PCB failure	Replace the wireless LAN PCB ASSY.
3	LAN terminal pin deformation Main PCB failure	Replace the main PCB ASSY.

4.6 Troubleshooting for Control Panel Problems

4.6.1 Nothing is displayed on the LCD

< User Check >

- Turn the power OFF/ON.

Step	Cause	Remedy
1	The version of the panel firmware and the main firmware do not match.	Install the latest panel firmware and main firmware.
2	Connection failure of the key PCB flat cable	Reconnect the key PCB flat cable.
3	Connection failure of the panel PCB harness	Reconnect the panel PCB harness.
4	Connection failure of the LCD flat cable	Reconnect the LCD flat cable.
5	Connection failure of the low-voltage power supply PCB harness	Reconnect the low-voltage power supply PCB harness.
6	AC cord failure	Replace the AC cord.
7	Panel PCB failure	Replace the panel PCB unit.
8	LCD failure	Replace the LCD.
9	Key PCB failure	Replace the panel cover ASSY.
10	Low-voltage power supply PCB failure	Replace the low-voltage power supply PCB unit.
11	Main PCB failure	Replace the main PCB ASSY.

4.6.2 Unable to perform panel operation

< User Check >

- Turn the power OFF/ON.

Step	Cause	Remedy
1	The version of the panel firmware and the main firmware do not match.	Install the latest panel firmware and main firmware.
2	Deviated adjustment of touch panel	Refer to "1.3.21 Adjustment of touch panel (Function code 61)" in Chapter 5 and perform adjustments.
3	Connection failure of the key PCB flat cable	Reconnect the key PCB flat cable.
4	Connection failure of the panel PCB harness	Reconnect the panel PCB harness.
5	Connection failure of the touch panel flat cable	Reconnect the touch panel flat cable.
6	Connection failure of the low-voltage power supply PCB harness	Reconnect the low-voltage power supply PCB harness.
7	Panel PCB failure	Replace the panel PCB unit.
8	LCD failure	Replace the LCD.
9	Key PCB failure	Replace the panel cover ASSY.
10	Low-voltage power supply PCB failure	Replace the low-voltage power supply PCB unit.
11	Main PCB failure	Replace the main PCB ASSY.

4.6.3 The machine does not enter the ready state when the power is turned ON

DISABLE the function selection mode at startup by following the procedures below.

- (1) Pull out the power cord and insert it again.
- (2) Hold down the **Home** key for about 5 seconds while the machine is in the ready state. The screen shown below is displayed on the LCD.

Memo:

If you cannot find the **Home** key, press the **Toner** key, and the **Home** key lights up.

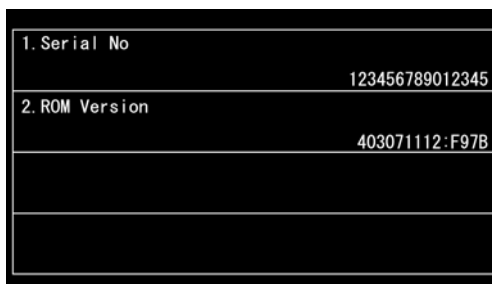

- (3) Hold down the blank space at the bottom of the LCD for about 2 seconds. The screen shown below is displayed on the LCD.



- (4) Press the *, 1, 9, 3, and 7 keys on the LCD in this order.
- (5) Press the 0, 0, 8, and 4 keys on the LCD in this order.
- (6) Press the ▲ or ▼ key to display "FUNC_DISABLE" on the LCD.
- (7) Press the **SET** key. The function selection at startup is disabled.
- (8) Press the **9** key twice to return the machine to the ready state.

4.7 Troubleshooting for Toner Cartridge and Drum Unit Problems

4.7.1 New toner not detected

< User Check >

- Check if the supplied toner cartridge is installed.
- Be sure to set a new toner cartridge.
- Install a genuine toner cartridge.

Step	Cause	Remedy
1	New toner actuator coming off	Re-assemble the new toner actuator.
2	Connection failure of the new toner sensor PCB harness	Reconnect the toner/new sensor PCB harness.
3	Main PCB failure	Replace the main PCB ASSY.

4.7.2 Toner cartridge not detected

< User Check >

- Re-assemble the toner cartridge.

Step	Cause	Remedy
1	High-voltage power supply PCB failure	Replace the high-voltage power supply PCB ASSY.
2	New toner sensor PCB failure	Replace the toner/new sensor PCB ASSY.
3	Main PCB failure	Replace the main PCB ASSY.

4.7.3 Toner replacement message displayed on LCD is not cleared

< User Check >

- Be sure to set a new toner cartridge.
- Install a genuine toner cartridge.

Step	Cause	Remedy
1	New toner actuator coming off	Re-assemble the new toner actuator.
2	Connection failure of the new toner sensor PCB harness	Reconnect the toner/new sensor PCB harness.
3	Main PCB failure	Replace the main PCB ASSY.

4.7.4 Drum error

< User Check >

- Clean the corona wire.
- Replace the drum unit with a new one.

Step	Cause	Remedy
1	Dirt on the GRID terminals or CHG terminals of the main body and the drum unit	Clean the GRID terminals and CHG terminals of the main body and the drum unit.
2	Dirt on the terminal of the high-voltage power supply PCB	Clean the terminal of the high-voltage power supply PCB.
3	High-voltage power supply PCB failure	Replace the high-voltage power supply PCB ASSY.
4	Toner sensor failure	Replace the toner/new sensor PCB ASSY.
5	Main PCB failure	Replace the main PCB ASSY.

4.7.5 Drum replacement message displayed on LCD is not cleared

< User Check >

- Refer to [“2.3 Counter Reset of Consumable Parts \(Drum unit/Belt unit\)”](#) in Chapter 5, and reset the drum counter.

Step	Cause	Remedy
1	Main PCB failure	Replace the main PCB ASSY.

4.8 Troubleshooting for Fuser Unit Problems

4.8.1 Fuser unit failure

Step	Cause	Remedy
1	Connection failure of the center thermistor harness	Reconnect the center thermistor harness.
2	Connection failure of the side thermistor harness	Reconnect the side thermistor harness.
3	Connection failure of the heater harness	Reconnect the heater harness.
4	Connection failure of the eject sensor PCB harness	Reconnect the eject sensor PCB harness.
5	Eject sensor PCB failure	Replace the eject sensor PCB ASSY.
6	Low-voltage power supply PCB failure	Replace the low-voltage power supply PCB unit.
7	Fuser unit failure	Replace the fuser unit.
8	Main PCB failure	Replace the main PCB ASSY.

Note:

- Turn the power OFF and then ON again. After the machine is left as it is for about 10 minutes, this problem may be resolved.
- If test print is performed in maintenance mode for service personnel, the machine may recover from the error. However, note that if this operation is performed while the heater has not cooled down, the fuser unit may melt.

4.9 Troubleshooting for Laser Unit Problems

4.9.1 Laser unit failure

Step	Cause	Remedy
1	Connection failure of the laser unit flat cable	Reconnect the laser unit flat cable.
2	Connection failure of the polygon motor harness	Reconnect the polygon motor harness.
3	Laser unit failure	Replace the laser unit.
4	Main PCB failure	Replace the main PCB ASSY.

4.10 Troubleshooting for PCB Problems

4.10.1 Main PCB failure

< User Check >

- Turn the power OFF/ON.
- Install the latest firmware.
- Check if PC-print is not prohibited.
- Check the print restricted ID.
- Replace the damaged DIMM.
- Check if print data is not damaged.

Step	Cause	Remedy
1	Main PCB failure	Replace the main PCB ASSY.

4.10.2 Full memory

< User Check >

- Print the stored data.
- Reduce the amount of data or lower the resolution.

Step	Cause	Remedy
1	Main PCB failure	Replace the main PCB ASSY.

4.10.3 Problem of print restriction/ID authentication

< User Check >

- Check if PC-print is not prohibited.
- Check the print restricted ID.

Step	Cause	Remedy
1	ID is forgotten	Execute Function code 01 to initialize the ID.
2	Main PCB failure	Replace the main PCB ASSY.

4.11 Document Feeding Problems

4.11.1 No feeding

< User Check >

- Load the document all the way, and check that the LCD display is changed.
- Check whether the number of loaded documents exceed the specified number.
- Check whether the ADF cover is properly closed.

Step	Cause	Remedy
1	Coming off of document detection actuator	Re-assemble the document detection actuator.
2	Coming off of ADF cover actuator	Re-assemble the ADF cover actuator.
3	Connection failure of the ADF motor harness	Reconnect the ADF motor harness.
4	Connection failure of the ADF cover/document detection sensor PCB harness	Reconnect the ADF cover/document detection sensor PCB harness.
5	Document separate roller failure	Replace the document separate roller ASSY.
6	ADF cover/document detection sensor failure	Replace the ADF cover/document detection sensor PCB ASSY.
7	ADF motor failure	Replace the ADF motor.
8	ADF drive gear damaged	Replace the ADF unit.
9	Main PCB failure	Replace the main PCB ASSY.

4.11.2 Double feeding

< User Check >

- Check whether the document is thicker than the specifications.
- Check whether the number of loaded documents exceed the specified number.

Step	Cause	Remedy
1	ADF separation pad worn out	Replace the ADF separation pad.

4.11.3 Paper jam

■ Paper jam in the ADF cover

< User Check >

- Check whether the document is thinner or thicker than the specifications.
- Check whether the document is smaller or larger than the specifications.
- Check whether the ADF cover is properly closed.
- Check whether the number of loaded documents exceed the specified number.

Step	Cause	Remedy
1	Foreign object inside the area around ADF cover	Remove the foreign object.
2	Coming off of second side document scanning position actuator	Re-assemble the second side document scanning position actuator.
3	Connection failure of the second side document scanning position sensor PCB harness	Reconnect the second side document scanning position sensor PCB harness.
4	Coming off of document pinch roller	Re-assemble the document pinch roller.
5	Second side CIS glass installation failure	Re-assemble the second side CIS glass.
6	Second side document hold installation failure	Re-assemble the second side document hold.
7	Document feed roller worn out	Replace the document feed roller ASSY2.
8	Second side document scanning position sensor failure	Replace the second side document scanning position sensor PCB ASSY.
9	ADF drive gear damaged	Replace the ADF unit.
10	Main PCB failure	Replace the main PCB ASSY.

■ Paper jam in the ADF

< User Check >

- Check whether the document is thinner or thicker than the specifications.
- Check whether the document is smaller or larger than the specifications.
- Check whether the document is wet or wrinkled.

Step	Cause	Remedy
1	Foreign object inside ADF	Remove the foreign object.
2	Coming off of First side document scanning position actuator	Re-assemble the first side document scanning position actuator.
3	Connection failure of the first side document scanning position sensor PCB harness	Reconnect the first side document scanning position sensor PCB harness.
4	Coming off of document pinch roller	Re-assemble the document pinch roller.
5	First side document hold installation failure	Re-assemble the first side document hold.
6	Scratch on ADF cover	Replace the ADF cover.
7	Document feed roller worn out	Replace the document feed roller ASSY2.
8	First side document scanning position sensor failure	Replace the first side document scanning position sensor PCB ASSY.
9	ADF drive gear damaged	Replace the ADF unit.
10	Scratch on document scanner unit	Replace the document scanner unit
11	Main PCB failure	Replace the main PCB ASSY.

■ Paper jam in the ADF eject section

< User Check >

- Check whether the document is thinner or thicker than the specifications.

Step	Cause	Remedy
1	Foreign object ADF eject section	Remove the foreign object.
2	First side document scanning position actuator caught on some position	Re-assemble the first side document scanning position actuator.
3	Coming off of exit pinch roller	Re-assemble the exit pinch roller.
4	First side document scanning position sensor failure	Replace the first side document scanning position sensor PCB ASSY.
5	ADF drive gear damaged	Replace the ADF unit.
6	Scratch on document scanner unit	Replace the document scanner unit.
7	Main PCB failure	Replace the main PCB ASSY.

4.11.4 Document becomes wrinkled

< User Check >

- Check whether the document is thinner or thicker than the specifications.
- Check whether the number of loaded documents exceed the specified number.
- Check whether the document does not curl.
- Check whether the document guide matches the document size.

Step	Cause	Remedy
1	Document separate roller worn out	Replace the document separate roller ASSY.
2	Document feed roller worn out	Replace the document feed roller ASSY2.
3	ADF drive gear damaged	Replace the ADF unit.

4.11.5 Document size cannot be correctly detected

< User Check >

- Check whether the document is thinner or thicker than the specifications.
- Check whether the number of loaded documents exceed the specified number.
- Check whether the document does not curl.

Step	Cause	Remedy
1	First side document scanning position actuator caught on some position	Re-assemble the first side document scanning position actuator.
2	ADF motor failure	Replace the ADF motor.
3	First side document scanning position sensor failure	Replace the first side document scanning position sensor PCB ASSY.
4	ADF drive gear damaged	Replace the ADF unit.
5	Main PCB failure	Replace the main PCB ASSY.

4.12 Scanning Image Defect Troubleshooting

4.12.1 Image defect examples

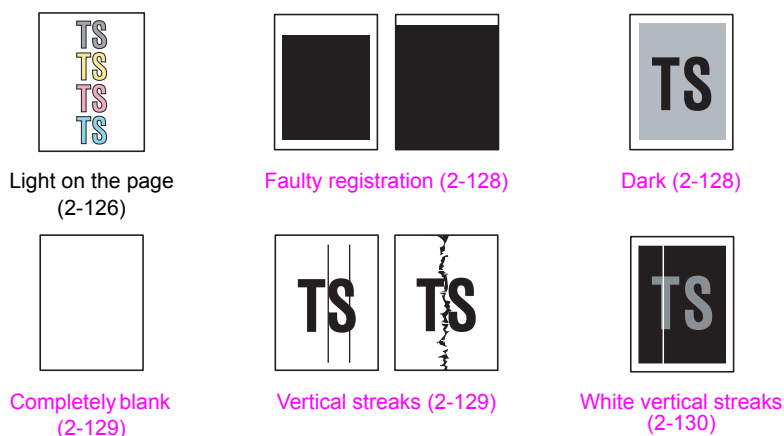

Fig. 2-16

4.12.2 Troubleshooting image defect

■ Light on the page



< User Check >

- Check whether the setting of the contrast does not become light.
- Clean the document glass or first side CIS glass.
- Clean the first side CIS glass of the ADF.

Step	Cause	Remedy
1	White level calibration data failure	Perform the acquisition of white level data. (Function code 55)
2	First side or second side CIS unit failure	Replace the first side or second side CIS unit.
3	Main PCB failure	Replace the main PCB ASSY.

■ Faulty registration



- First side (Document scanner unit)

Step	Cause	Remedy
1	Fine adjustment of scan start position misalignment	Perform the fine adjustment of scan start position. (Function code 54)
2	First side document scanning position actuator caught on some position	Re-assemble the first side document scanning position actuator.
3	First side CIS unit failure	Replace the first side CIS unit.
4	Main PCB failure	Replace the main PCB ASSY.

- Second side (ADF unit)

Step	Cause	Remedy
1	Fine adjustment of scan start position misalignment	Perform the fine adjustment of scan start position. (Function code 54)
2	Second side document scanning position actuator caught on some position	Re-assemble the second side document scanning position actuator.
3	Second side CIS unit failure	Replace the second side CIS unit.
4	Main PCB failure	Replace the main PCB ASSY.

■ Dark

< User Check >



- Check whether the setting of the contrast does not become dark.
- Clean the second side document hold.

Step	Cause	Remedy
1	White level calibration data failure	Perform the acquisition of white level data. (Function code 55)
2	Dirt on the second side document hold	Clean the second side document hold. Or replace the ADF unit.
3	Dirt on the black reference tape of the document scanner unit	Clean the glass of the black reference tape part. Or replace the document scanner unit.
4	First side or second side CIS unit failure	Replace the first side or second side CIS unit.
5	Main PCB failure	Replace the main PCB ASSY.

■ **Completely blank**

< User Check >



- Check if the first side and second side of the document are reversed.

Step	Cause	Remedy
1	White level calibration data failure	Perform the acquisition of white level data. (Function code 55)
2	Second side CIS flat cable damaged	Replace the second side CIS flat cable.
3	First side CIS flat cable damaged	Replace the first side CIS flat cable.
4	First side or second side CIS unit failure	Replace the first side or second side CIS unit.
5	Main PCB failure	Replace the main PCB ASSY.

■ **Vertical streaks**



< User Check >

- Clean the first side CIS glass or document glass.
- Clean the second side CIS glass.
- Clean the document hold.

Step	Cause	Remedy
1	Foreign object inside the document scanner unit	Remove the foreign object.
2	Foreign object inside the second side CIS glass	Remove the foreign object.
3	Dirt on each roller of the ADF	Clean each roller of the ADF.
4	Dirt on the ADF paper feed section	Clean the ADF paper feed section.
5	Dirt inside the second side CIS glass	Clean inside the second side CIS glass.
6	Dirt inside the document scanner unit	Clean inside the document scanner unit.
7	First side or second side CIS unit failure	Replace the first side or second side CIS unit.
8	Scratch on second side CIS glass	Replace the ADF unit.
9	Scratch on document glass or first side CIS glass	Replace the document scanner unit.

■ **White vertical streaks**

< User Check >



- Clean the first side CIS glass or document glass.
- Clean the second side CIS glass.

Step	Cause	Remedy
1	Foreign object inside the document scanner unit	Remove the foreign object.
2	Foreign object inside the second side CIS glass	Remove the foreign object.
3	Dirt on each roller of the ADF	Clean each roller of the ADF.
4	Dirt on the ADF paper feed section	Clean the ADF paper feed section.
5	Dirt inside the second side CIS glass	Clean inside the second side CIS glass.
6	Dirt inside the document scanner unit	Clean inside the document scanner unit.
7	First side or second side CIS unit failure	Replace the first side or second side CIS unit.
8	Scratch on second side CIS glass	Replace the ADF unit.
9	Scratch on document glass or first side CIS glass	Replace the document scanner unit.

4.13 Troubleshooting of FAX Functions

4.13.1 FAX can't send it

< User Check >

- Check whether the line cord is correctly inserted into the socket.
- Check whether the dialing function setting (tone/pulse) is correct.
- Check whether the FAX document is correctly loaded on the ADF.

Step	Cause	Remedy
1	Connection failure of the modem PCB flat cable	Reconnect the modem PCB flat cable.
2	Connection failure of the panel PCB harness	Reconnect the panel PCB harness.
3	Connection failure of the touch panel flat cable	Reconnect the touch panel flat cable.
4	Connection failure of the ADF cover/document detection sensor PCB harness	Reconnect the ADF cover/document detection sensor PCB harness.
5	Coming off of document detection actuator	Re-assemble the document detection actuator.
6	Coming off of ADF cover actuator	Re-assemble the ADF cover actuator.
7	Disconnection of line cord	Replace the line cord.
8	ADF cover/document detection sensor failure	Replace the ADF cover/document detection sensor PCB ASSY.
9	ADF motor failure	Replace the ADF motor.
10	First side or second side CIS unit failure	Replace the First side or second side CIS unit.
11	ADF drive gear damaged	Replace the ADF unit.
12	Failure of paper feed section of document scanner unit	Replace the document scanner unit.
13	Panel PCB failure	Replace the panel PCB unit.
14	Touch panel failure	Replace the touch panel ASSY.
15	Key PCB failure	Replace the panel cover ASSY.
16	Modem PCB failure	Replace the modem PCB ASSY.
17	Main PCB failure	Replace the main PCB ASSY.

4.13.2 FAX cannot be received

< User Check >

- Check whether the line cord is correctly inserted into the socket.
- Check the reception mode settings are correct.

Step	Cause	Remedy
1	Connection failure of the modem PCB flat cable	Reconnect the modem PCB flat cable.
2	Disconnection of line cord	Replace the line cord.
3	Modem PCB failure	Replace the modem PCB ASSY.
4	Main PCB failure	Replace the main PCB ASSY.

4.13.3 No bell ring

< User Check >

- Check whether the number of telephone rings is set to zero (0).
- Check whether the bell volume is set to zero (0).

Step	Cause	Remedy
1	Connection failure of the speaker harness	Reconnect the speaker harness.
2	Connection failure of the modem PCB flat cable	Reconnect the modem PCB flat cable.
3	Disconnection of line cord	Replace the line cord.
4	Modem PCB failure	Replace the modem PCB ASSY.
5	Main PCB failure	Replace the main PCB ASSY.

4.13.4 A communication error occurs

< User Check >

- Check whether the source of noise is around the machine.

Step	Cause	Remedy
1	Connection failure of the modem PCB flat cable	Reconnect the modem PCB flat cable.
2	Disconnection of line cord	Replace the line cord.
3	Modem PCB failure	Replace the modem PCB ASSY.
4	Main PCB failure	Replace the main PCB ASSY.

4.13.5 Receive buffer full during receiving into memory

< User Check >

- Print the print data stored in the memory.
- Divide the print data and print it.

Step	Cause	Remedy
1	Main PCB failure	Replace the main PCB ASSY.

4.14 Troubleshooting for Other Problems

4.14.1 Cannot make print

< User Check >

- Turn the power OFF/ON.
- Properly insert the USB cable.
- Properly insert the LAN cable.
- Check if the maximum number of pages that can be printed is exceeded.
- Check if PC-print is not prohibited.
- Check the print restricted ID.
- Check if print data is not damaged.

Step	Cause	Remedy
1	Forgot the print restricted ID	Clear the old ID and get a new ID by Function code 01.
2	Connection failure of the wireless LAN harness ASSY	Reconnect the wireless LAN harness ASSY.
3	Wireless LAN PCB failure	Replace the wireless LAN PCB ASSY.
4	Main PCB failure	Replace the main PCB ASSY.

4.14.2 Problem of USB direct interface

< User Check >

- Replace the USB flash memory.
- Check if the extension of the data in the USB flash memory is correct.

Step	Cause	Remedy
1	Connection failure of the USB host relay PCB harness	Reconnect the USB host relay PCB harness.
2	USB host PCB failure	Replace the USB host PCB ASSY.
3	Main PCB failure	Replace the main PCB ASSY.

4.14.3 Cannot update firmware

< User Check >

- Check if other function is being in process.
- Turn the power OFF/ON.

Step	Cause	Remedy
1	Firmware version does not match	Reinstall the latest versions of all the firmwares in the order of the sub firmware, panel firmware, main firmware, and high-voltage firmware. (The panel firmware is available only for the model with touch panel.)
2	Main PCB failure	Replace the main PCB ASSY.

4.14.4 The machine is not turned ON

< User Check >

- Turn the power OFF/ON.
- Properly insert the AC cord.

Step	Cause	Remedy
1	Connection failure of the panel PCB harness	Reconnect the panel PCB harness.
2	Connection failure of the LCD flat cable	Reconnect the LCD flat cable.
3	Connection failure of the low-voltage power supply PCB harness	Reconnect the low-voltage power supply PCB harness.
4	Disconnection of AC cord	Replace the AC cord.
5	Panel PCB failure	Replace the panel PCB unit.
6	LCD failure	Replace the LCD.
7	Low-voltage power supply PCB failure	Replace the low-voltage power supply PCB unit.
8	Main PCB failure	Replace the main PCB ASSY.

CHAPTER 3 DISASSEMBLY AND ASSEMBLY

1. SAFETY PRECAUTIONS

To avoid creating secondary problems by mishandling, follow the warnings and precautions below during maintenance work.

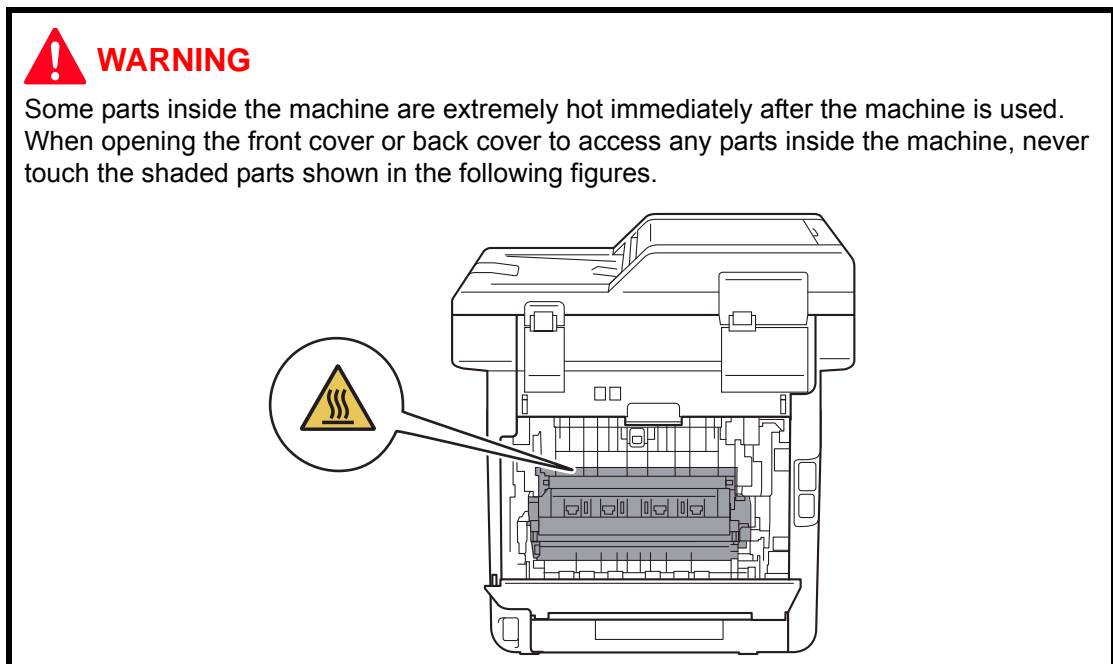

Note:

- Be careful not to lose screws, washers, or other parts removed.
- Be sure to apply grease to the gears and applicable positions specified in this chapter.
- When using soldering irons or other heat-generating tools, take care not to accidentally damage parts such as wires, PCBs and covers.
- Static electricity charged in your body may damage electronic parts. When transporting PCBs, be sure to wrap them in conductive sheets.
- When replacing the PCB and all the other related parts, put on a grounding wrist band and perform the job on a static mat. Also take care not to touch the conductor sections on the flat cables or on the wire harness.
- After disconnecting flat cables, check that each cable is not damaged at its end or short-circuited.
- When connecting flat cables, do not insert them at an angle. After insertion, check that the cables are not at an angle.
- When connecting or disconnecting harnesses, hold the connector body, not the cables. If the connector is locked, release it first.
- After a repair, check not only the repaired portion but also handling of harnesses. Also check that other related portions are functioning properly before operational checks.
- After an assembly, recommend the operation of “dielectric strength voltage check” and “continuity check”.
- There must be no damage in the insulation sheet.
- After a repair, update the firmware to the latest version.

2. PACKING

<A4 model>

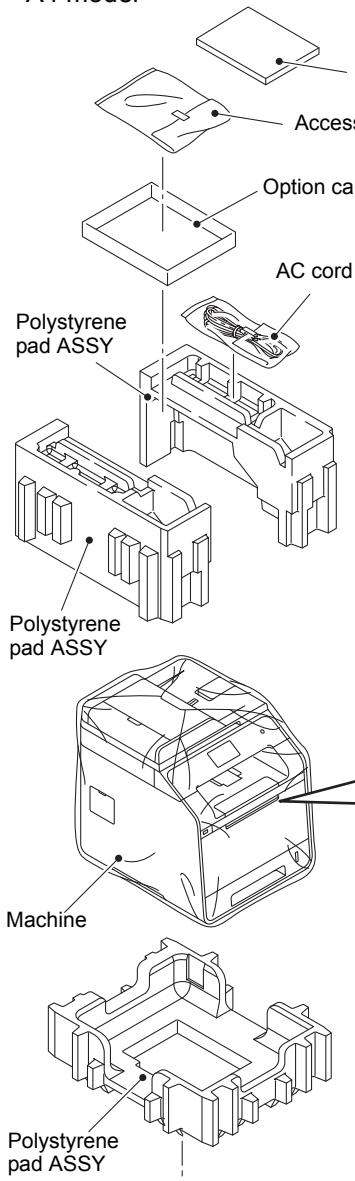

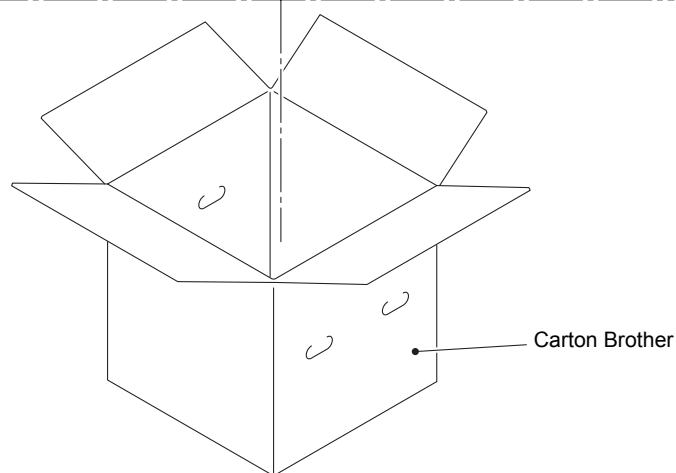
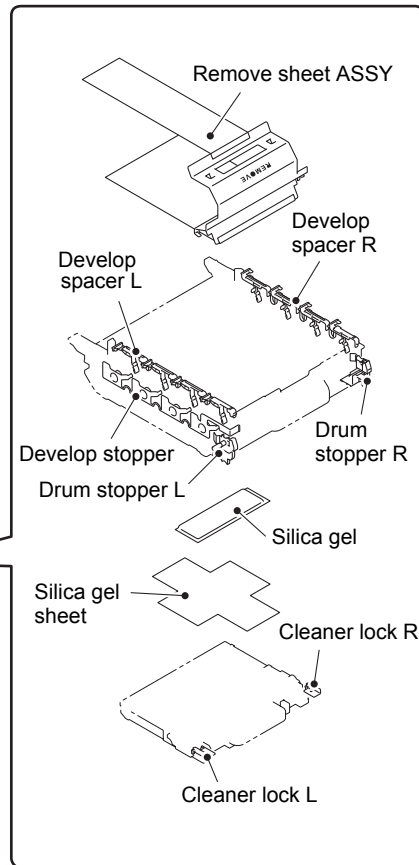
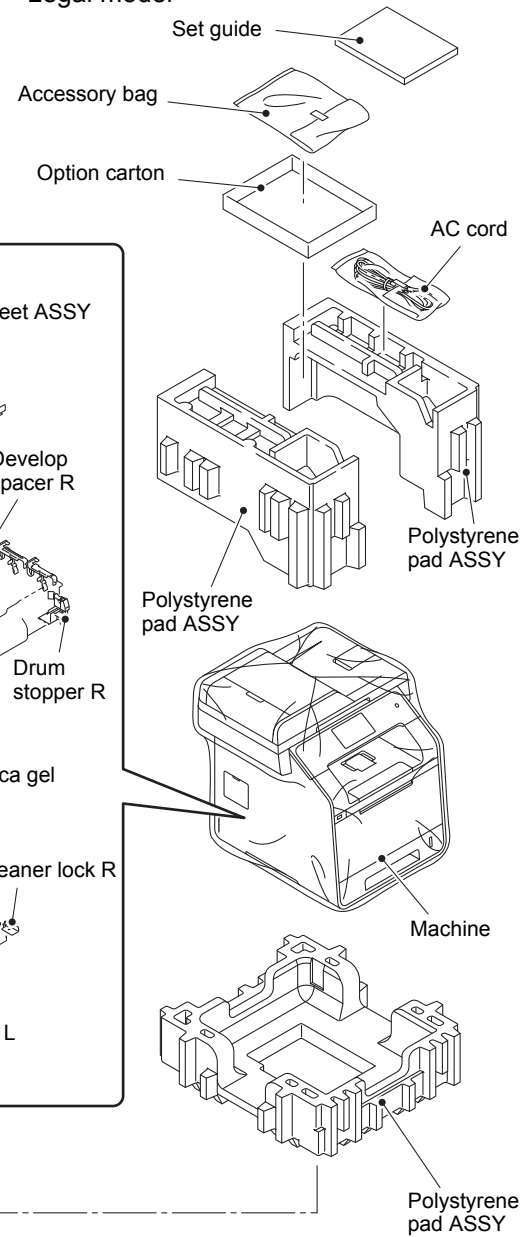

<Legal model>



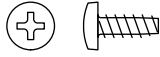
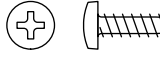

3. SCREW CATALOGUE



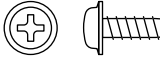

Taptite bind B

Taptite bind B M3x8	
Taptite bind B M3x10	
Taptite bind B M4x10	
Taptite bind B M4x12	

Taptite cup B

Taptite cup B M3x10	
Taptite cup B M3x12	
Taptite cup B M4x12	

Taptite cup S

Taptite cup S M3x6 SR	
Taptite cup S M3x8 SR	
Taptite cup S M3x10 SR	
Taptite cup S M3x12	

Taptite B

Taptite B M3x6	
-------------------	---



Taptite flat B

Taptite flat B M3x10	
-------------------------	---

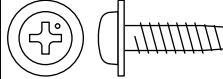

Taptite pan

Taptite pan B M4x14	
---------------------	---

Screw pan (S/P washer)

Screw pan (S/P washer) M3x6	
Screw pan (S/P washer) M3.5x6	

Taptite pan (washer)

Taptite pan (washer) B M4x12 DA	
Taptite pan B M3x10	

Screw bind

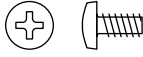
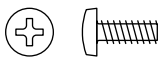
Screw bind M3x6	
Screw bind M3x8	

4. SCREW TORQUE LIST

Note:

For verifying the shape of each screw, refer to “3. SCREW CATALOGUE” in this chapter.

Location of screw	Screw type	Q' ty	Tightening torque N·m (kgf·cm)
Fuser cover L	Taptite bind B M4x12	2	0.8±0.1 (8±1)
Fuser cover R	Taptite bind B M4x12	2	0.8±0.1 (8±1)
Fuser unit	Taptite pan B M4x14	2	0.8±0.1 (8±1)
Side cover L	Taptite B 3x6	1	0.45±0.05 (4.5±0.5)
	Taptite bind B M4x12	4	0.8±0.1 (8±1)
Side cover R	Taptite B 3x6	1	0.45±0.05 (4.5±0.5)
	Taptite bind B M4x12	3	0.8±0.1 (8±1)
Duplex tray	Taptite cup B M3x12	2	0.5±0.1 (5±1)
Front cover damper spring	Taptite B 3x6	1	0.3±0.05 (3±0.5)
Back cover upper	Taptite bind B M4x12	2	0.8±0.1 (8±1)
Panel FG harness	Screw bind M3x8	1	0.5±0.05 (5±0.5)
Main shield cover plate ASSY	Screw bind M3x8 (Upper side)	1	0.5±0.05 (5±0.5)
	Screw bind M3x8 (Lower side)	2	0.8±0.1 (8±1)
ADF earth harness	Screw bind M3x8	1	0.5±0.05 (5±0.5)
Document scanner FG harness	Screw bind M3x8	1	0.5±0.05 (5±0.5)
ADF unit	Taptite bind B M4x12	2	0.8±0.1 (8±1)
Hinge ASSY L	Taptite cup S M3x12	3	0.8±0.1 (8±1)
Hinge R support	Taptite cup B M3x10	1	0.5±0.05 (5±0.5)
Document scanner unit	Taptite bind B M4x12	4	0.7±0.1 (7±1)
	Taptite cup B M4x12	2	0.7±0.1 (7±1)
Upper ADF chute	Taptite cup B M3x10	1	0.5±0.05 (5±0.5)
ADF unit	Taptite cup B M3x10	1	0.5±0.05 (5±0.5)
Upper ADF chute	Taptite cup B M3x10	5	0.5±0.05 (5±0.5)
Lower ADF chute	Taptite cup B M3x10	3	0.5±0.05 (5±0.5)
ADF FG harness	Taptite cup S M3x8 SR	1	0.7±0.1 (7±1)
Drive frame ASSY	Taptite cup B M3x10	3	0.5±0.05 (5±0.5)
ADF motor	Screw pan (S/P washer) M3x6	1	0.6±0.1 (6±1)
Control panel ASSY (A4 model)	Taptite cup B M3x10	4	0.5±0.1 (5±1)
Control panel ASSY (Legal model)	Taptite bind B M4x12	2	0.7±0.1 (7±1)
LCD hold plate	Taptite cup B M3x10	3	0.45±0.05 (4.5±0.5)
Panel control PCB shield plate cover	Taptite cup B M3x10	4	0.45±0.05 (4.5±0.5)
Document scanner top cover ASSY	Taptite bind B M4x12	6	0.7±0.1 (7±1)

Location of screw	Screw type	Q' ty	Tightening torque N·m (kgf·cm)
Joint cover top	Taptite bind B M4x12	8	0.8±0.1 (8±1)
Modem FG harness	Screw pan (S/P washer) M3.5x6	1	0.5±0.05 (5±0.5)
Modem ground harness	Screw pan (S/P washer) M3.5x6	1	0.5±0.05 (5±0.5)
Modem shield cover	Taptite bind B M4x12	2	0.7±0.1 (7±1)
	Screw pan (S/P washer) M3.5x6	1	0.5±0.05 (5±0.5)
Modem PCB ASSY	Taptite cup S M3x6 SR	2	0.5±0.05 (5±0.5)
Back cover upper	Taptite bind B M4x12	4	0.8±0.1 (8±1)
Joint cover USB ASSY	Taptite bind B M4x12	1	0.8±0.1 (8±1)
Main PCB ASSY	Screw bind M3x6 (Upper/Middle side)	2	0.5±0.05 (5±0.5)
	Screw bind M3x6 (Lower side)	1	0.8±0.1 (8±1)
Joint cover base ASSY	Taptite bind B M4x12	9	0.8±0.1 (8±1)
Scanner cover plate	Taptite bind B M4x12	6	0.8±0.1 (8±1)
	Taptite cup S M3x6 SR	4	0.8±0.1 (8±1)
Scanner holder	Taptite cup S M3x6 SR	5	0.8±0.1 (8±1)
Side ground plate L	Taptite cup S M3x8 SR	2	0.8±0.1 (8±1)
Main PCB plate	Screw bind M3x8	2	0.8±0.1 (8±1)
PF cable rack	Taptite cup S M3x8 SR	1	0.8±0.1 (8±1)
Under bar ground spring	Taptite cup S M3x8 SR	1	0.8±0.1 (8±1)
Process drive unit	Taptite bind B M4x12	5	0.8±0.1 (8±1)
	Taptite pan (washer) B M4x12 DA	1	0.8±0.1 (8±1)
	Screw pan (S/P washer) M3.5x6	1	0.5±0.05 (5±0.5)
Main drive unit	Taptite bind B M4x12	4	0.8±0.1 (8±1)
Develop release drive unit	Taptite bind B M4x12	3	0.8±0.1 (8±1)
Paper eject ASSY	Taptite bind B M4x12	4	0.8±0.1 (8±1)
Registration mark sensor unit	Taptite bind B M3x10	2	0.5±0.1 (5±1)
FG harness of the Inlet harness ASSY	Screw pan (S/P washer) M3.5x6	1	0.5±0.05 (5±0.5)
Inlet harness ASSY	Taptite flat B M3x10	1	0.5±0.05 (5±0.5)
Drive ground plate	Screw pan (S/P washer) M3.5x6	1	0.5±0.05 (5±0.5)
LVPS plate	Taptite cup S M3x8 SR	2	0.5±0.05 (5±0.5)
	Taptite bind B M4x12	2	0.8±0.1 (8±1)
Low-voltage power supply PCB unit	Taptite cup S M3x6 SR	5	0.5±0.05 (5±0.5)
MP upper cover ASSY	Taptite bind B M3x10	2	0.4±0.1 (4±1)
MP paper empty/ registration front sensor PCB ASSY	Taptite bind B M3x8	1	0.4±0.1 (4±1)
Paper feed unit	Taptite cup B M3x12	1	0.4±0.1 (4±1)
	Taptite bind B M4x12	2	0.8±0.1 (8±1)

Location of screw	Screw type	Q' ty	Tightening torque N·m (kgf·cm)
Registration front/ rear sensor PCB holder	Taptite bind B M3x10	1	0.5±0.1 (5±1)
MP drive frame	Taptite bind B M3x10	3	0.5±0.1 (5±1)
High-voltage power supply PCB ASSY	Taptite pan B M3x10	1	0.5±0.1 (5±1)
T2 cover rear	Taptite cup S M3x10 SR	2	0.8±0.1 (8±1)
T2 cover left	Taptite cup S M3x6 SR	2	0.8±0.1 (8±1)
T2 cover right	Taptite cup S M3x6 SR	2	0.8±0.1 (8±1)
T2 relay PCB ASSY	Taptite cup S M3x6 SR	1	0.8±0.1 (8±1)
T2 beam F ASSY	Taptite cup S M3x6 SR	5	0.8±0.1 (8±1)
T2 solenoid holder ASSY	Taptite cup S M3x6 SR	1	0.8±0.1 (8±1)
T2 beam front	Taptite cup S M3x6 SR	2	0.8±0.1 (8±1)
T2 beam rear	Taptite cup S M3x6 SR	4	0.8±0.1 (8±1)
T2 frame L unit	Taptite bind B M4x10	1	0.8±0.1 (8±1)

5. LUBRICATION

The kind of the lubricating oil (Maker name)	Lubrication point	Quantity of lubrication
PG661 (W) (TORAY)	Joint cover base ASSY	1.0 to 1.5 mm dia. ball PG1.0 to 1.5
BDX-313 (A) (Kanto Kasei)	Hinge ASSY L	2.0 mm dia. ball BDX2.0
	Hinge R (thin rib)	2.0 mm dia. ball BDX2.0
	Hinge R (thick rib)	3.0 mm dia. ball BDX3.0
	Back cover	2.0 mm dia. ball BDX2.0

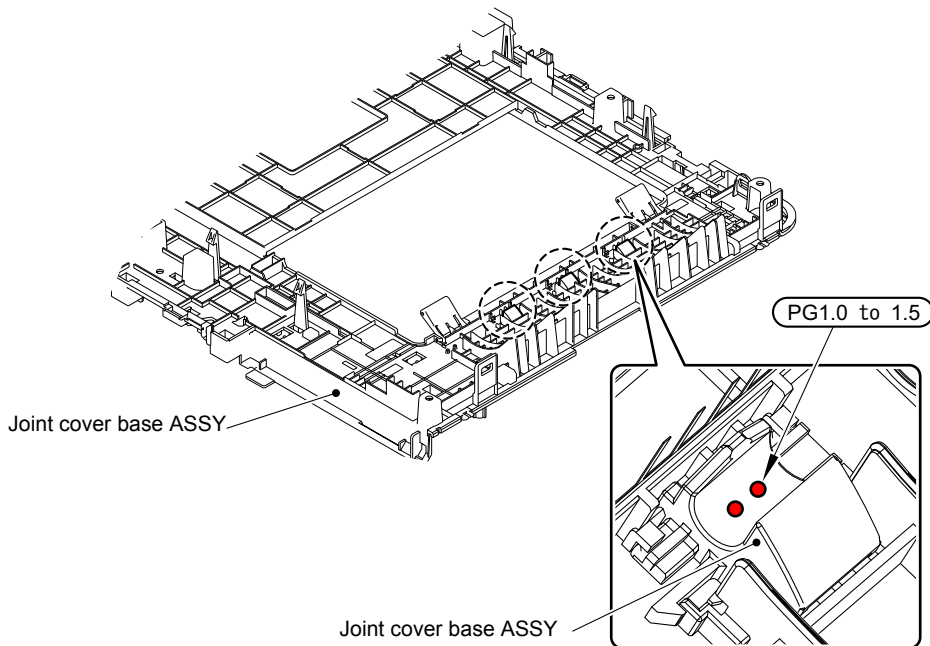

PG1.0 to 1.5: PG661 (W) (1.0 to 1.5 mm dia. ball)

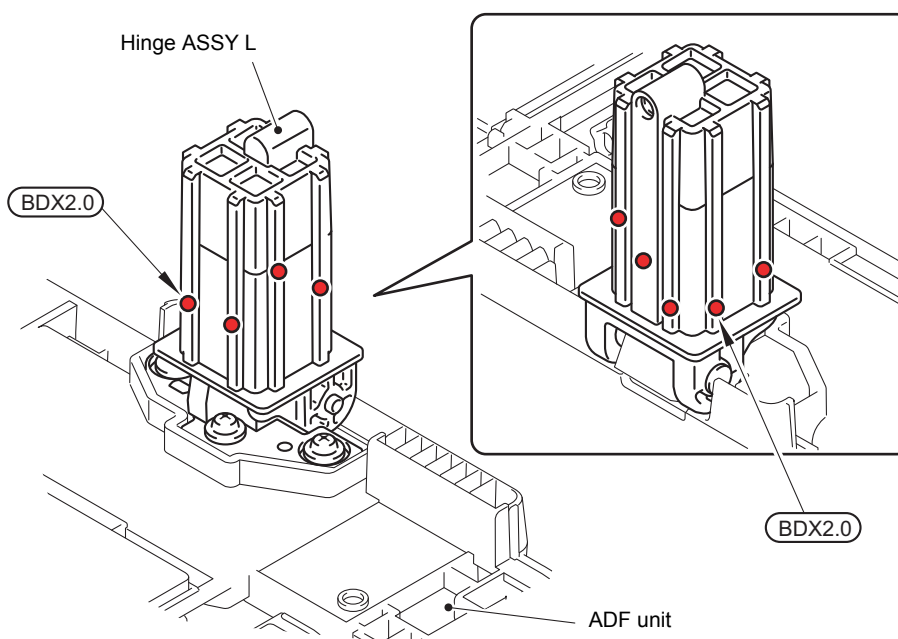

BDX2.0: BDX-313 (A) (2.0 mm dia. ball)

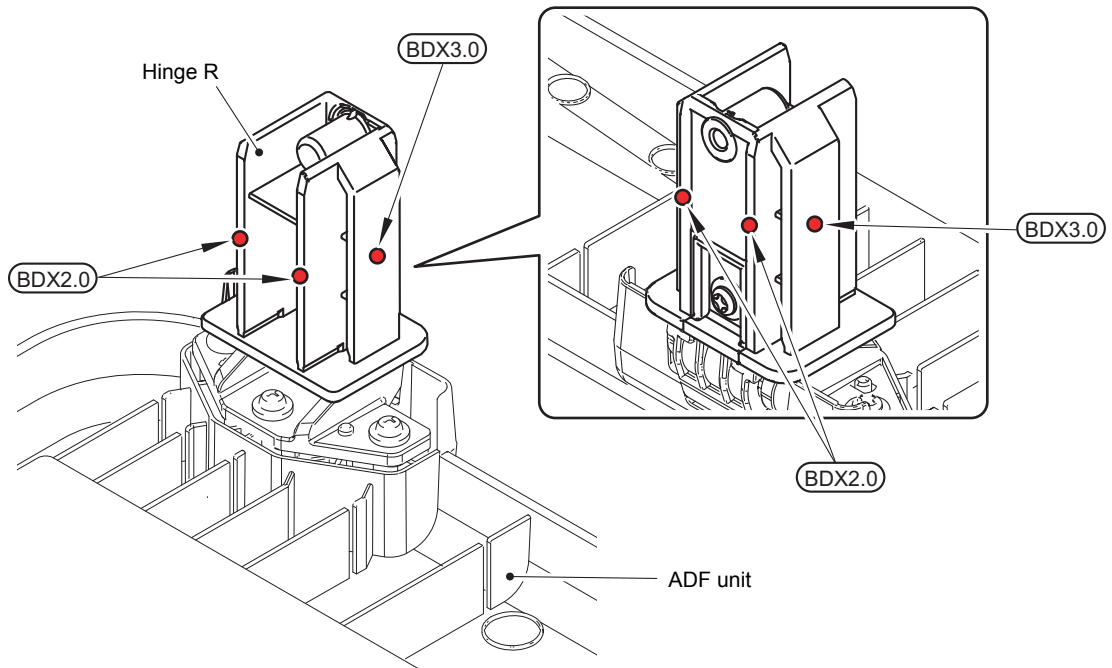

(thin rib) BDX2.0: BDX-313 (A) (2.0 mm dia. ball)

(thick rib) BDX3.0: BDX-313 (A) (3.0 mm dia. ball)

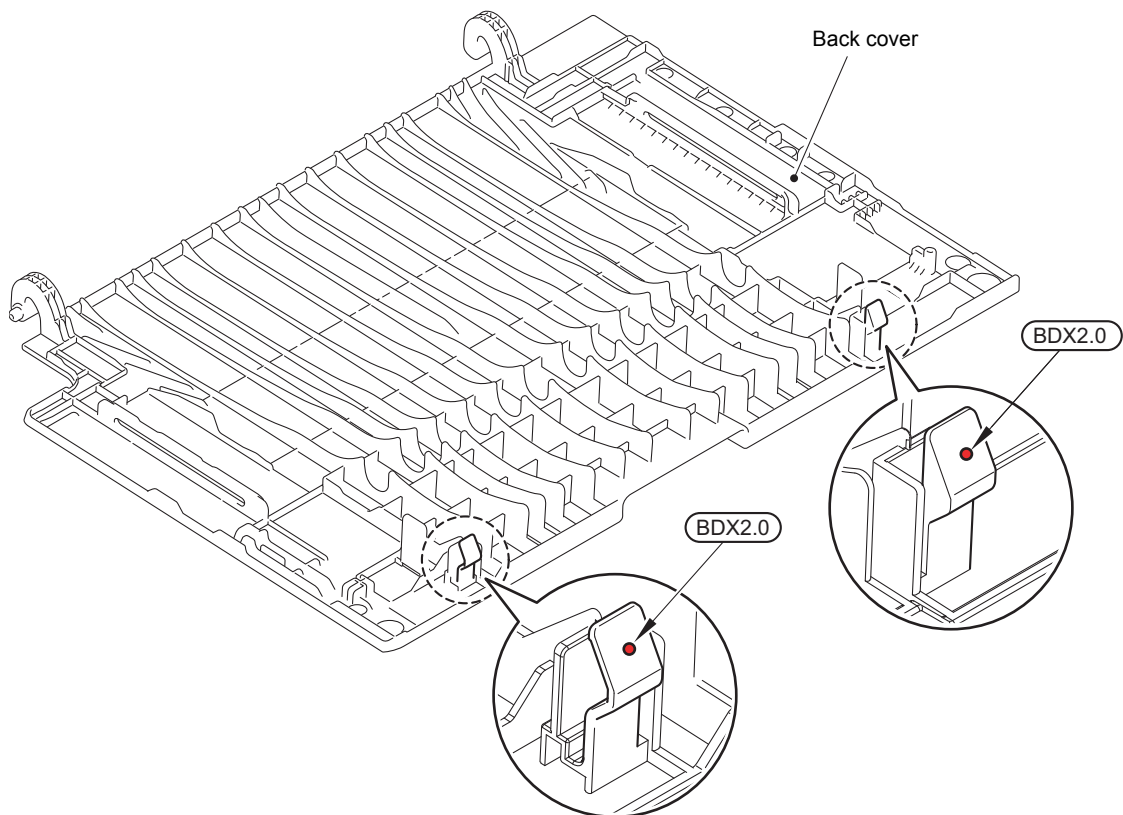

BDX2.0: BDX-313 (A) (2.0 mm dia. ball)

6. OVERVIEW OF GEARS

When ordering spare parts, please refer to Parts reference list.

■ Main frame L ASSY

<Layout view>

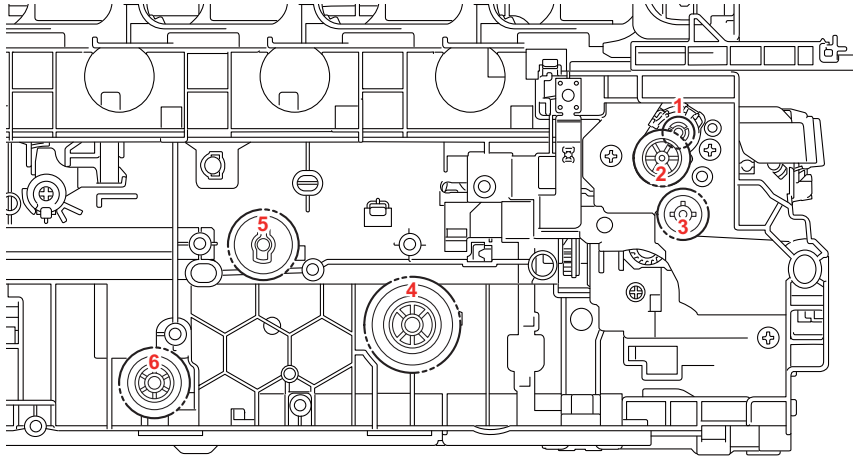

<Development view>

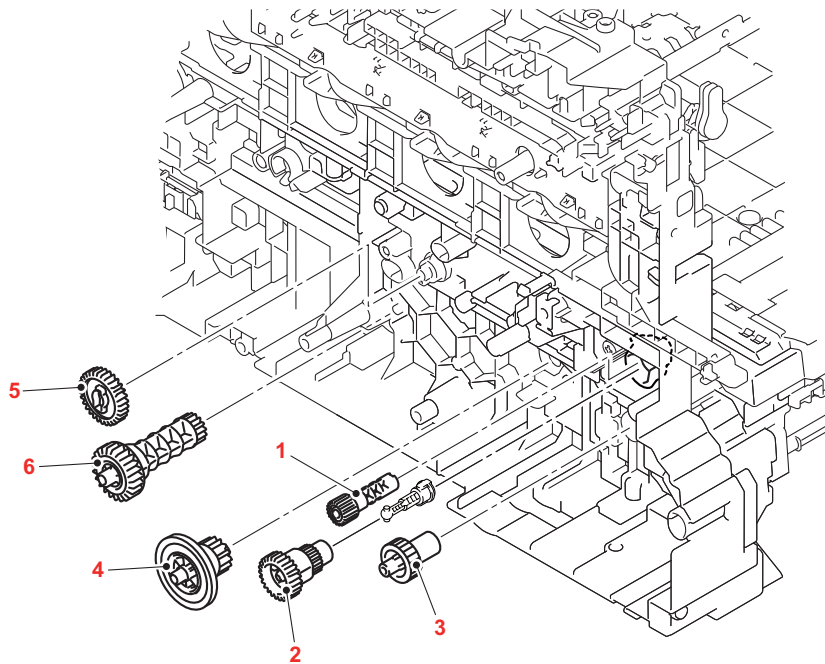

<Name of gears>

1	LY0299	Pinch roller drive gear Z21M05
2	LY1816	Registration gear Z26-23
3	LY0164	PF drive gear 21
4	LY0166	PP gear 14 55
5	LY6128	Cleaner drive gear Z30
6	LY1817	DX drive gear Z15-23

* These parts are subject to change without notice.

7. HARNESS ROUTING

1 Laser Unit

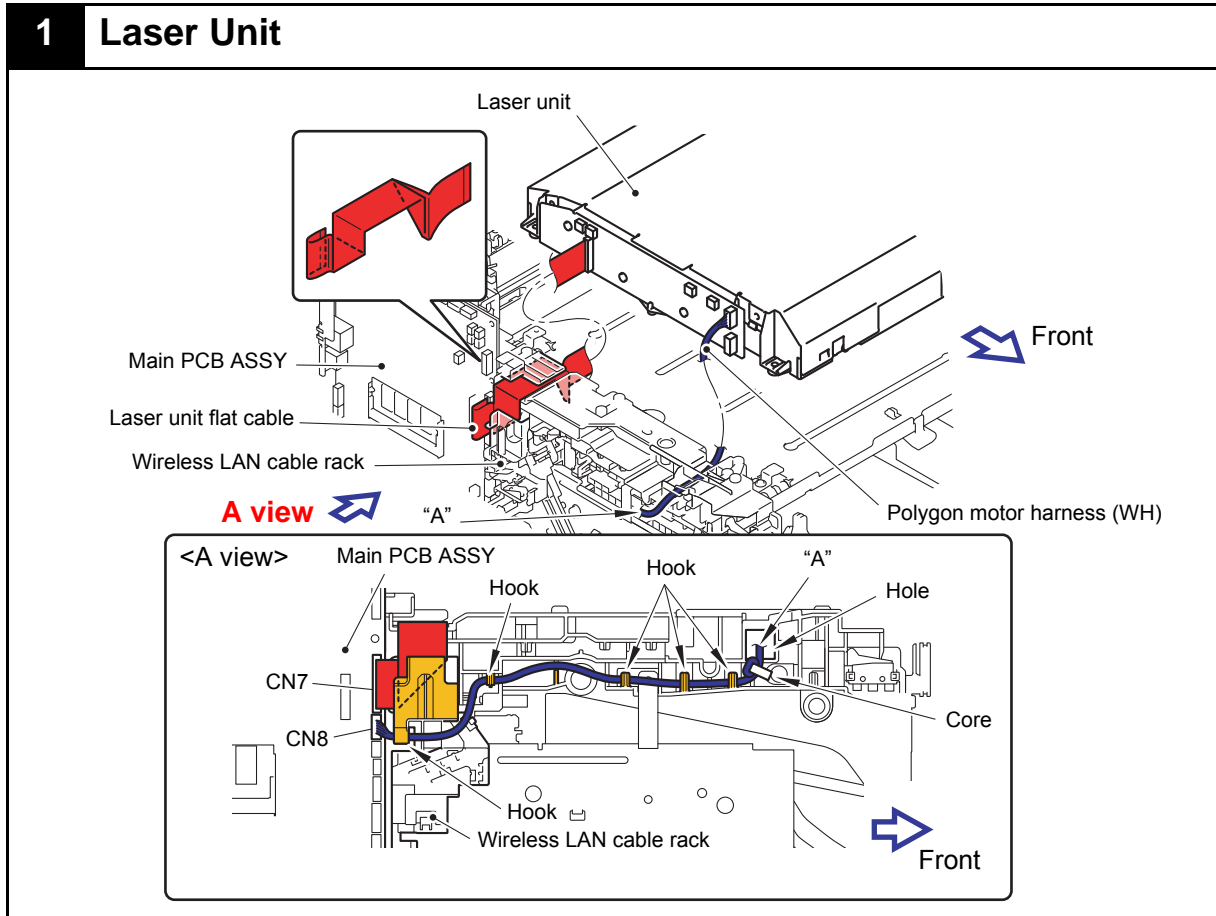

Harness colors may be changed for any reason.

2 Process Drive Unit, Front Cover Sensor, Main Drive Unit

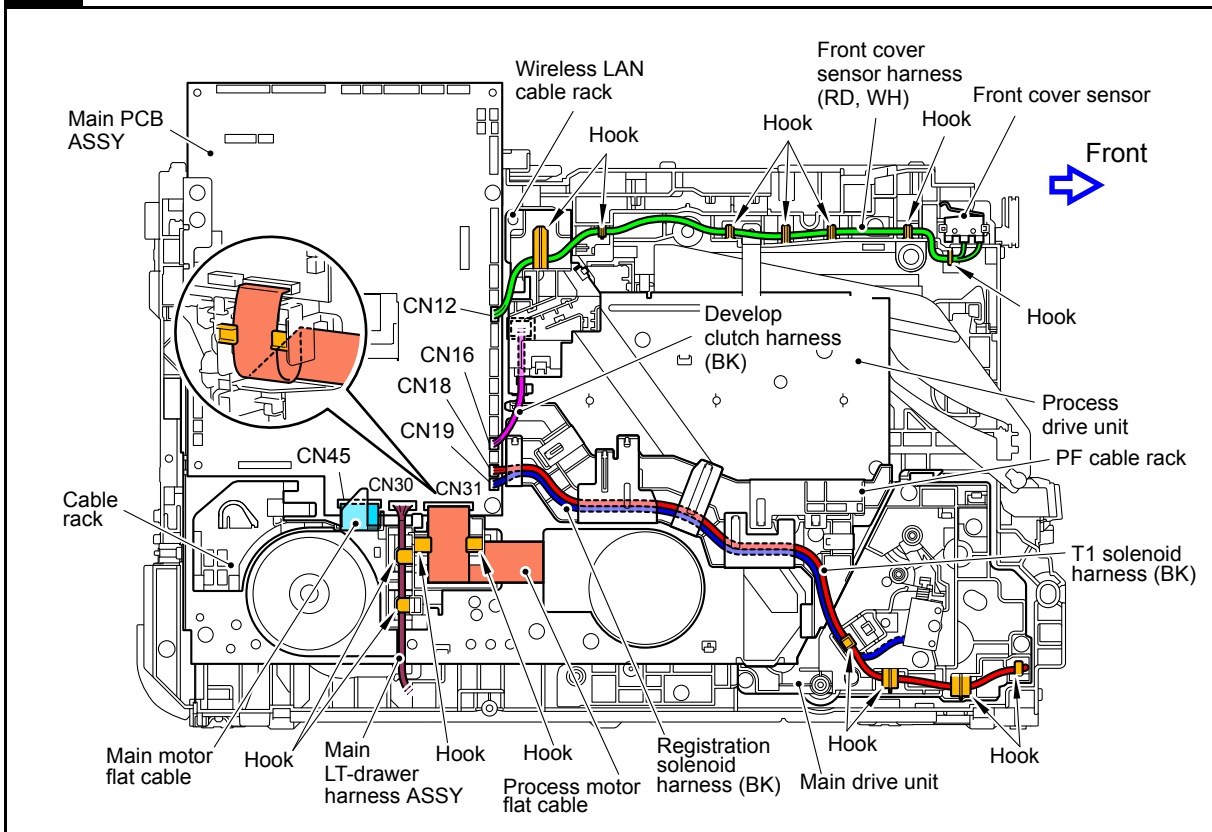

3 Develop Release Drive Unit, Develop Release Sensor PCB ASSY, Toner/New Sensor PCB ASSY

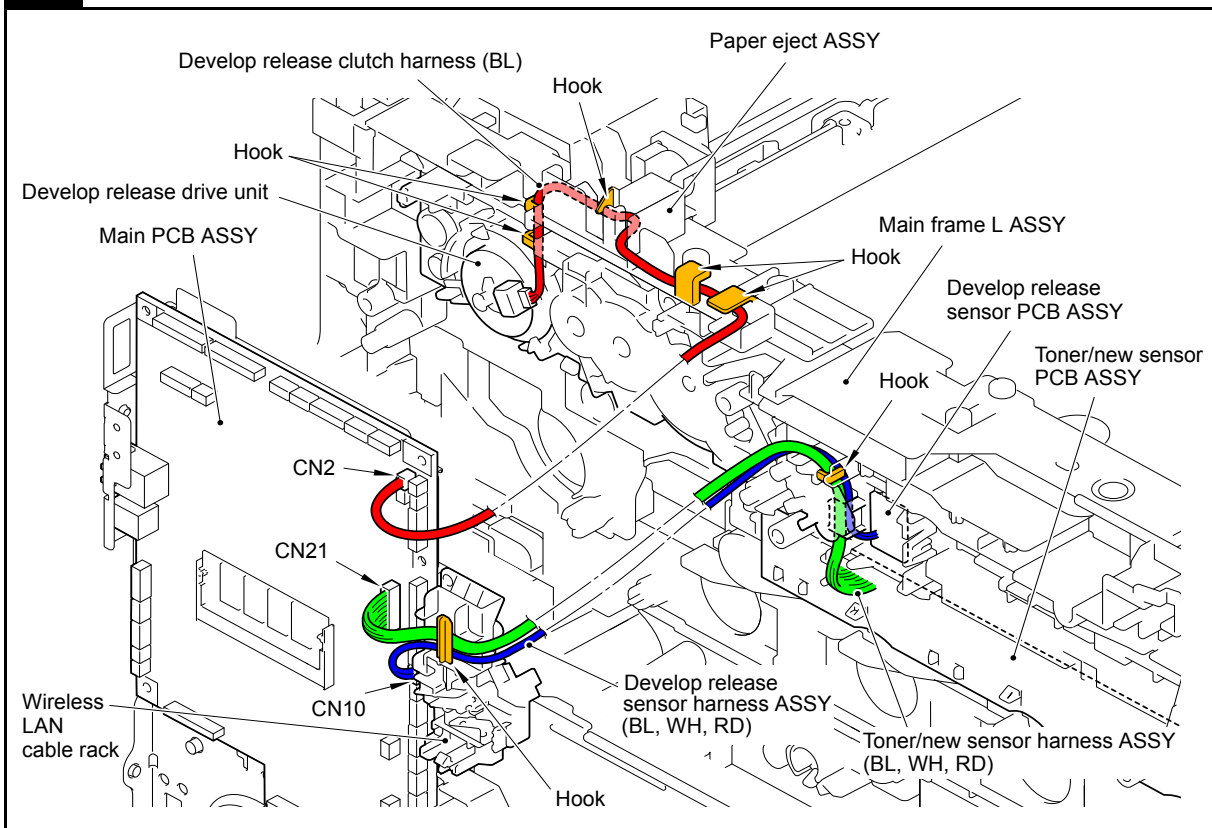

Harness colors may be changed for any reason.

4 Paper Eject ASSY

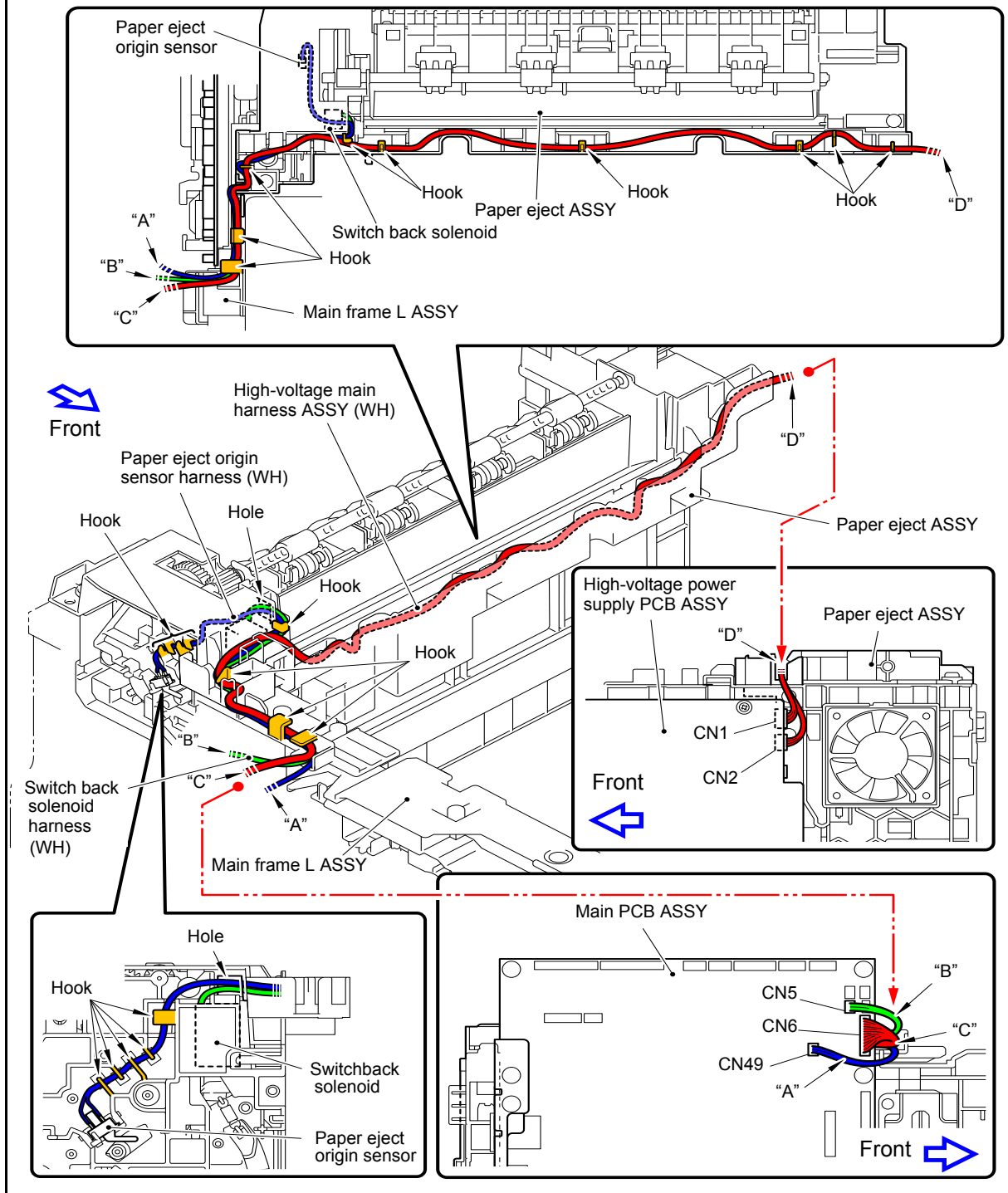

Harness colors may be changed for any reason.

5 Back Cover Sensor ASSY

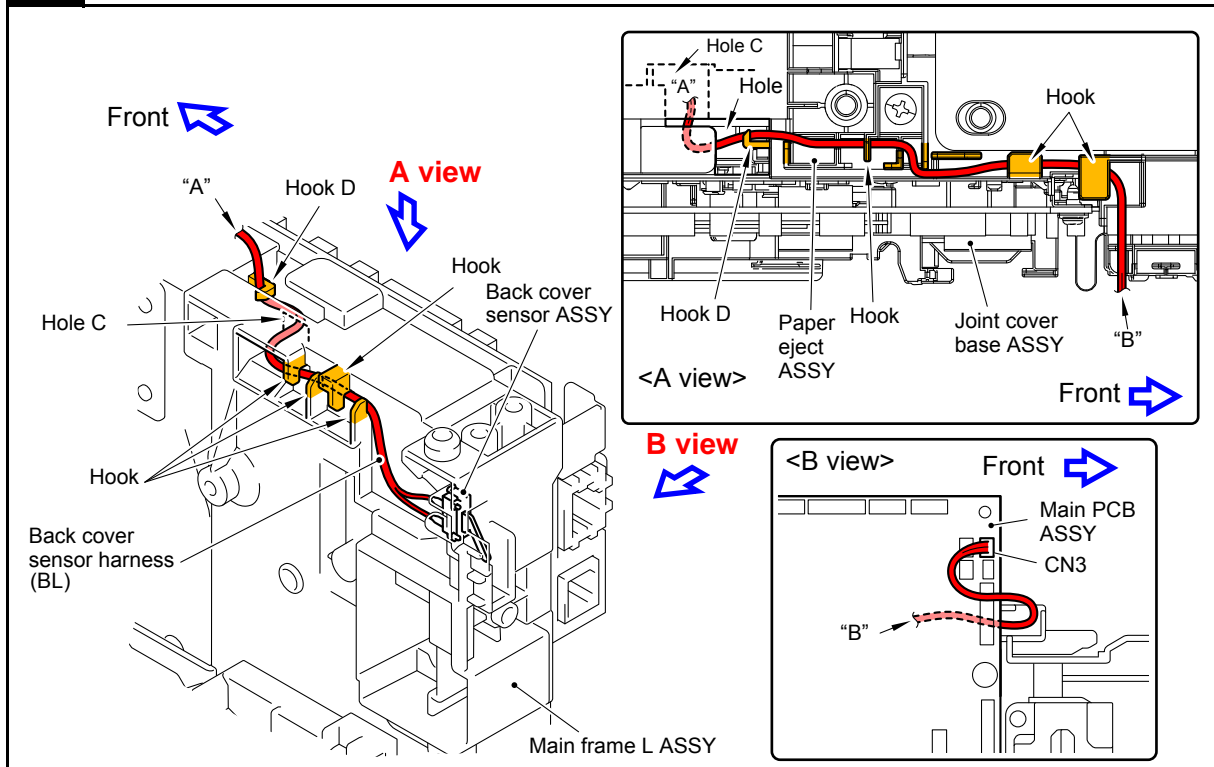

6 Eject Sensor PCB ASSY, Fuser Unit

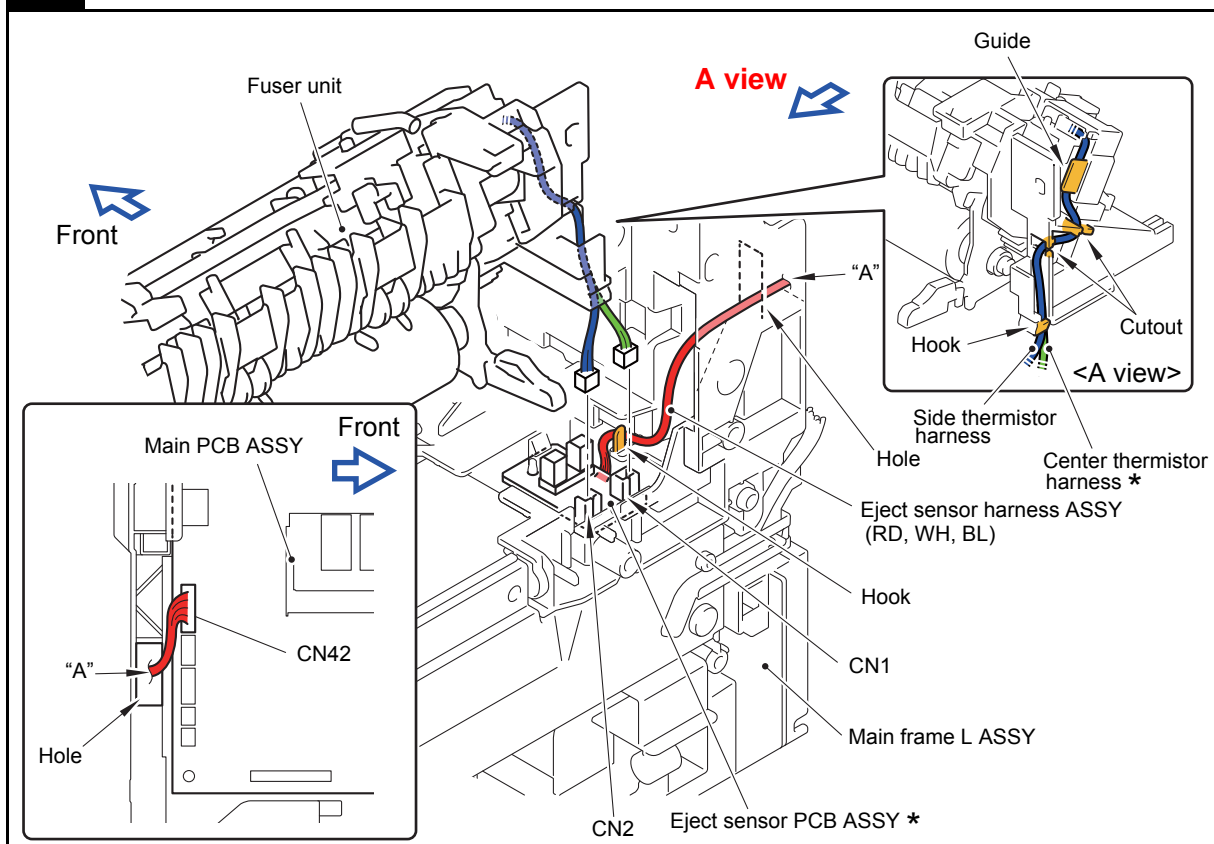

Harness colors may be changed for any reason.

* Center thermistor has a black and blue connectors (230V models only). The black connector may be connected to the blue insertion port and vice versa.

7 Registration Mark Sensor Unit

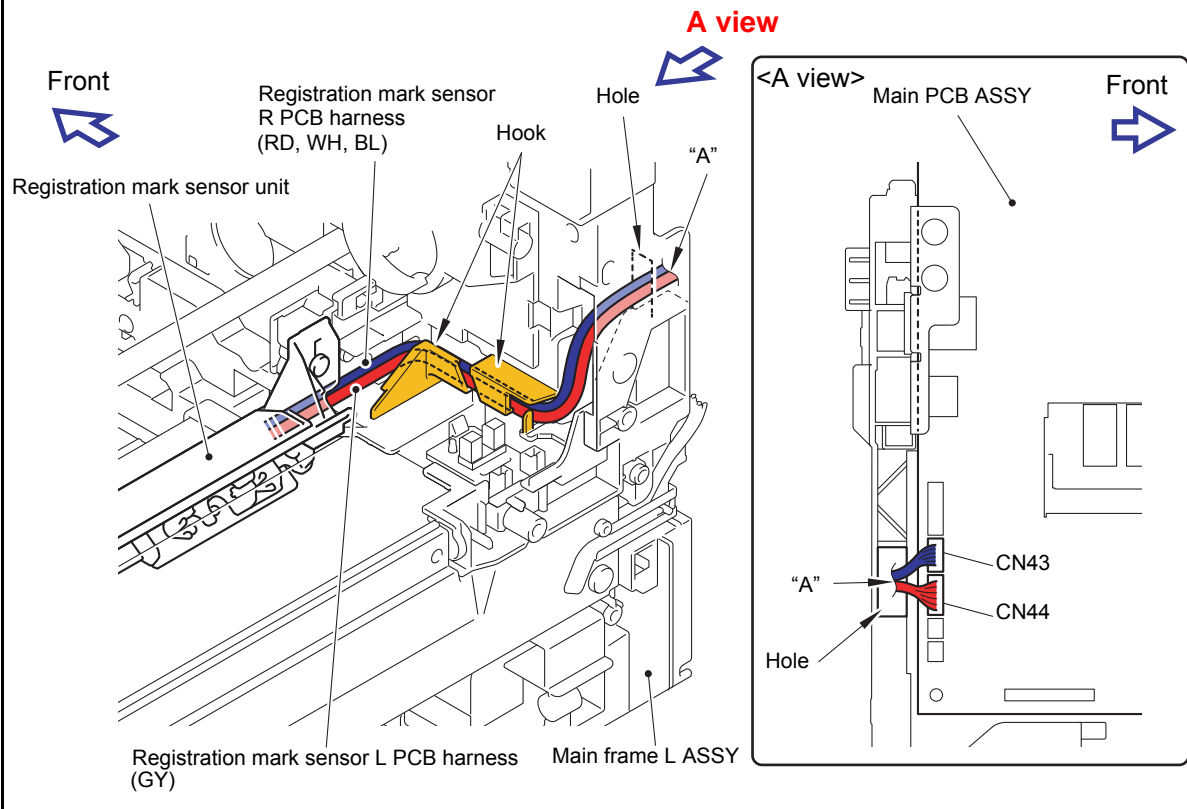

8 Fuser Fan, Power Fan

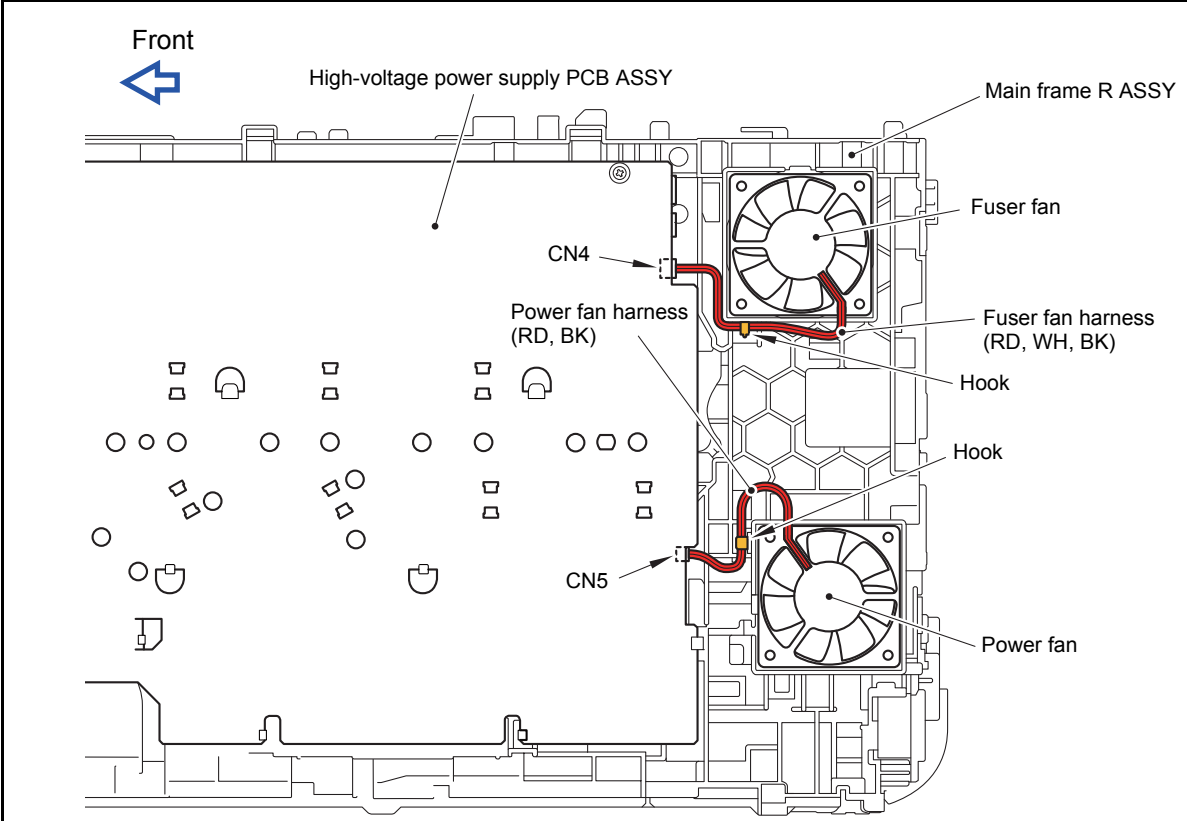

Harness colors may be changed for any reason.

9 Low-voltage Power Supply PCB Unit

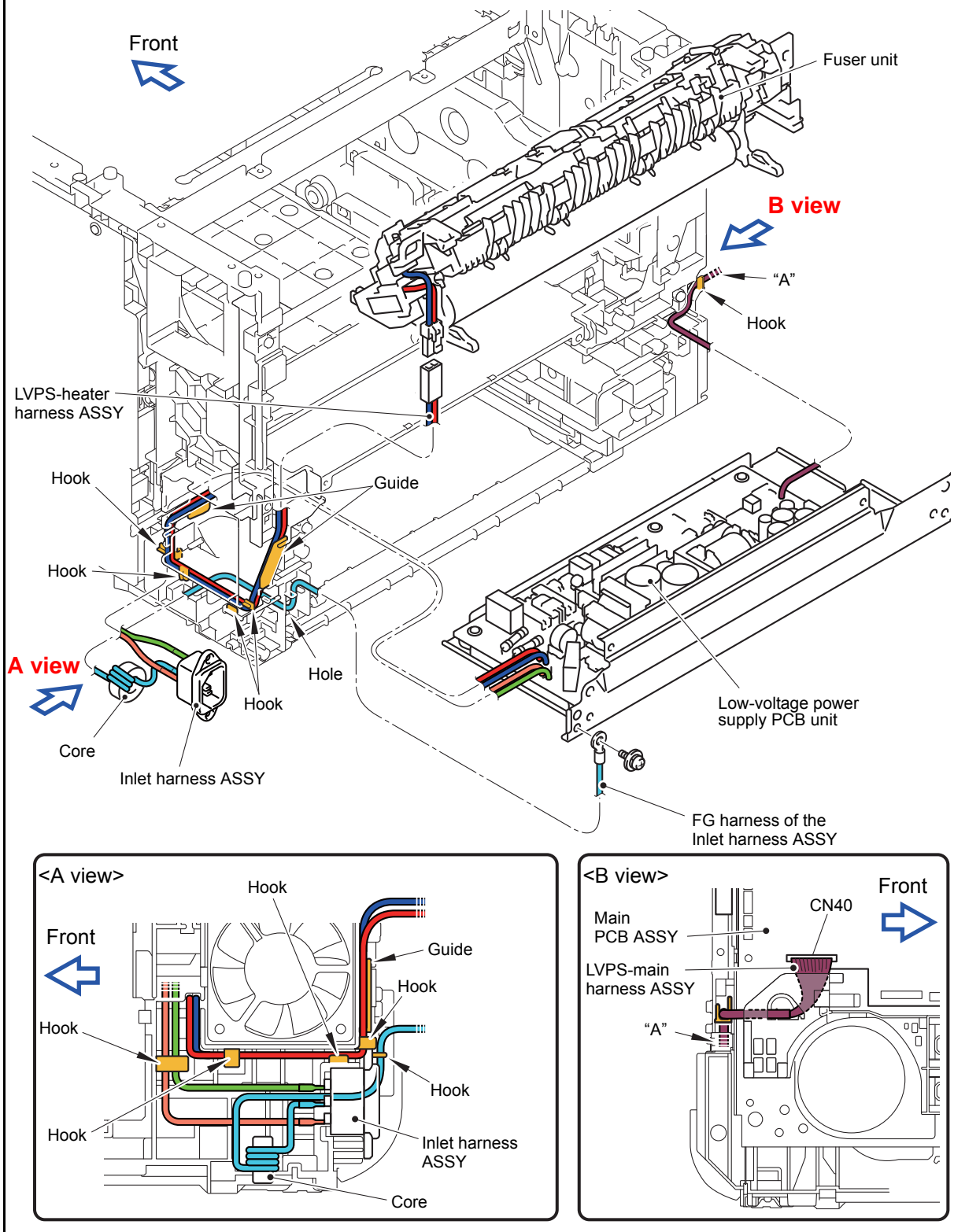

Harness colors may be changed for any reason.

10 MP Paper Empty/Registration Front Sensor PCB ASSY

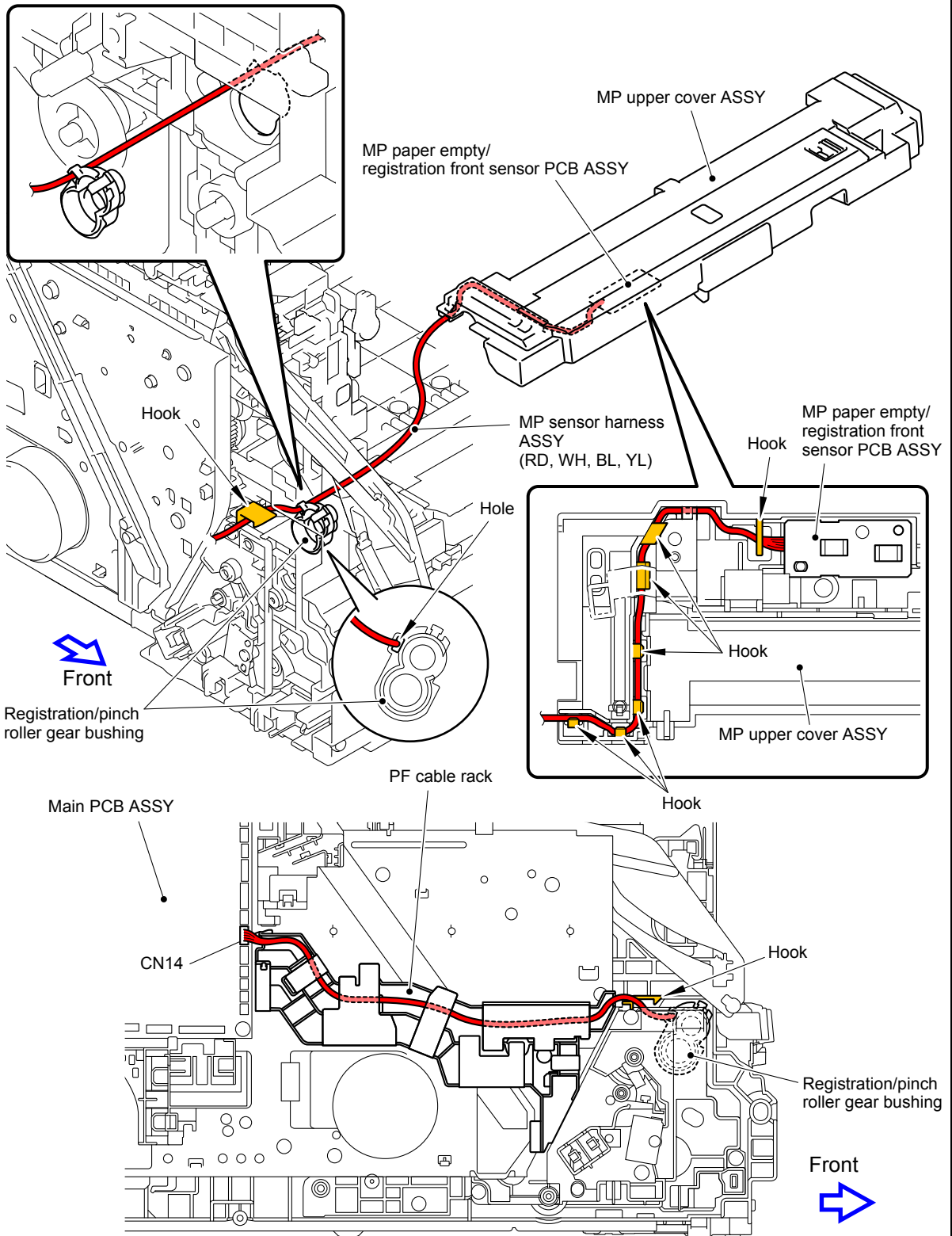

Harness colors may be changed for any reason.

11 Paper Feed Unit

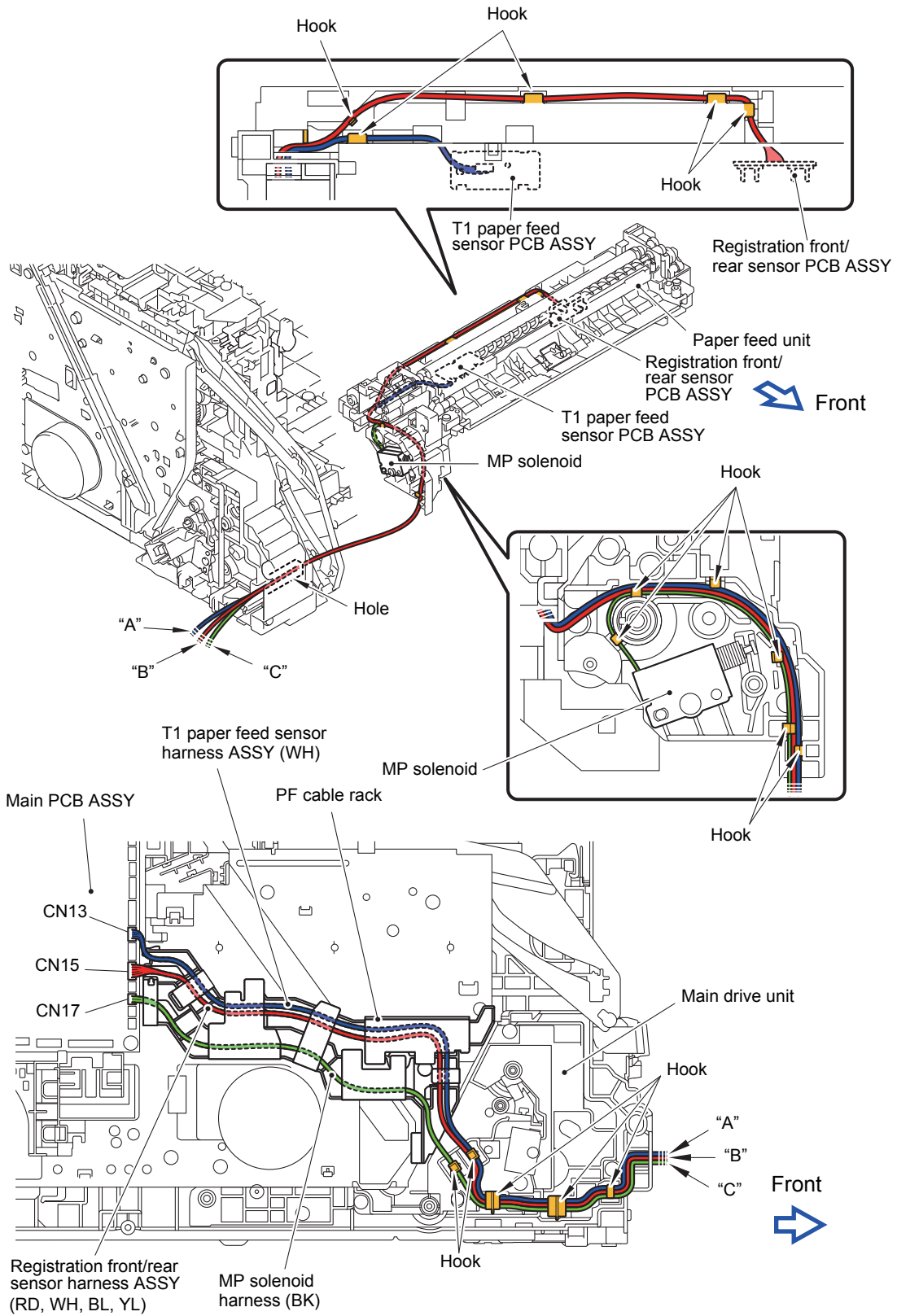

Harness colors may be changed for any reason.

12 Blower, Waste Toner Sensor

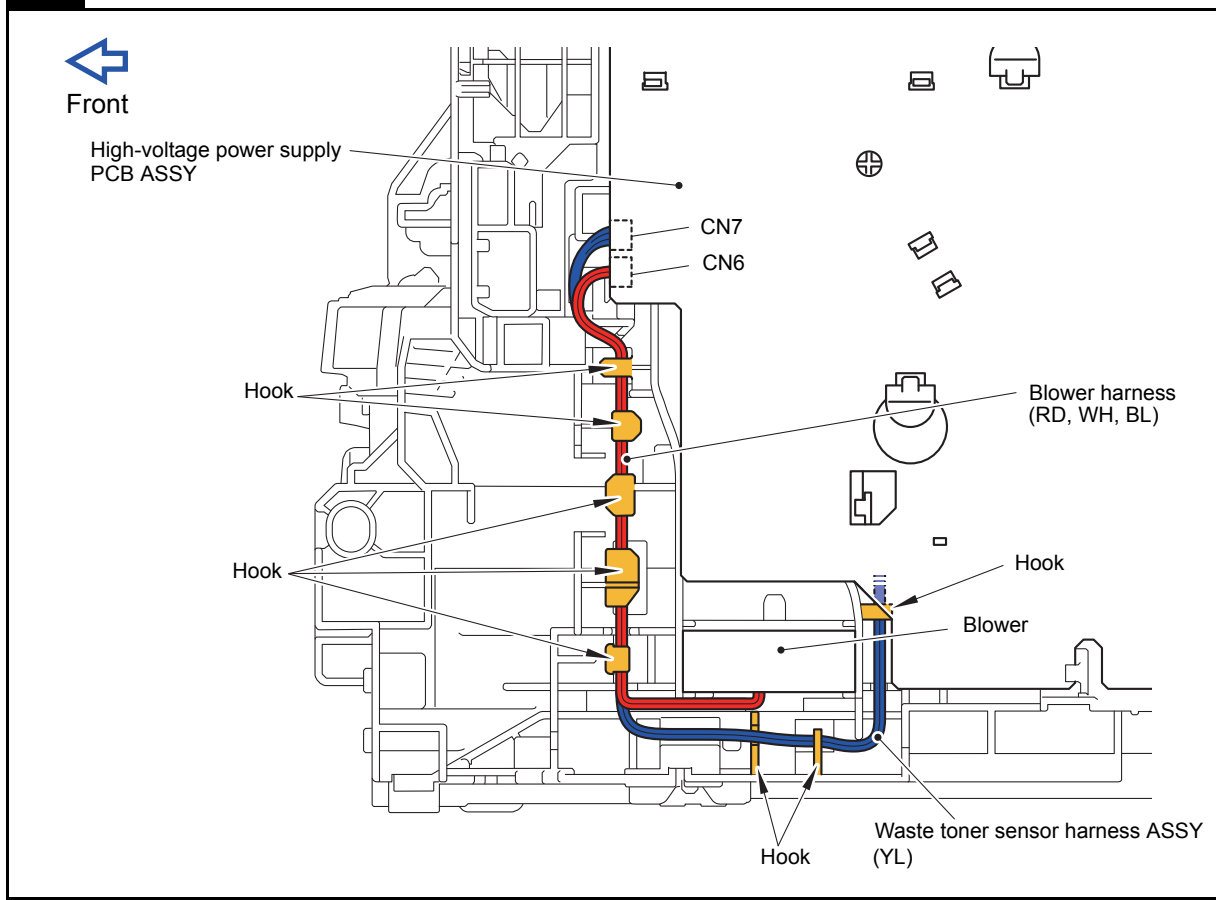

Harness colors may be changed for any reason.

13 ADF (A4 model)

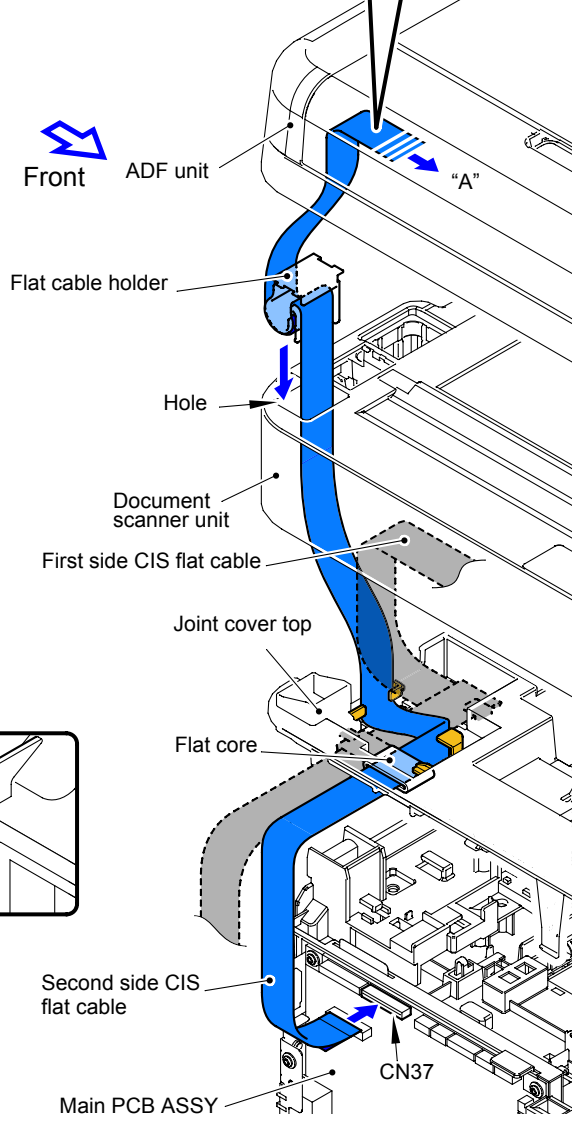
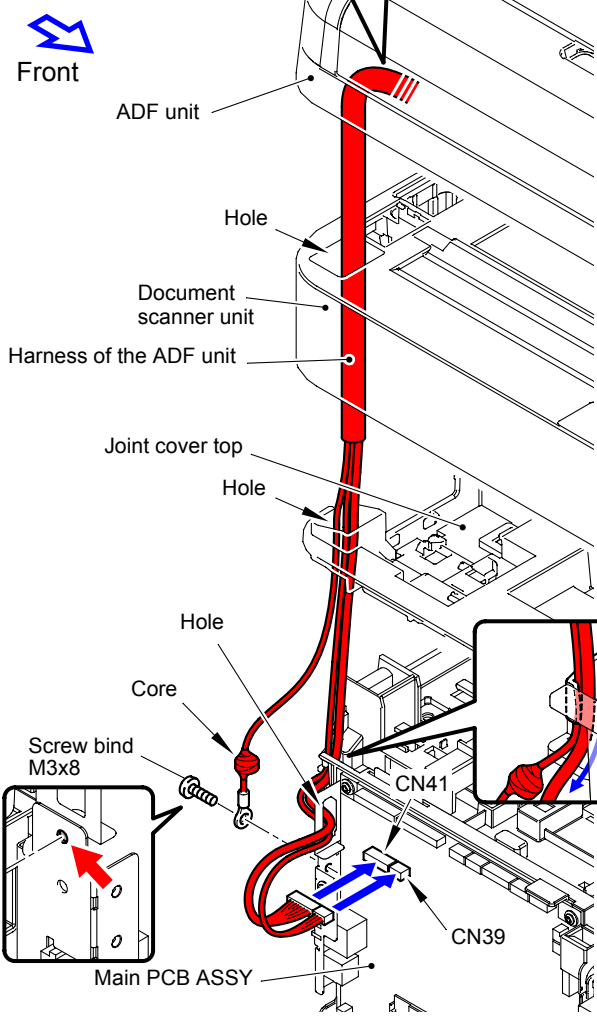
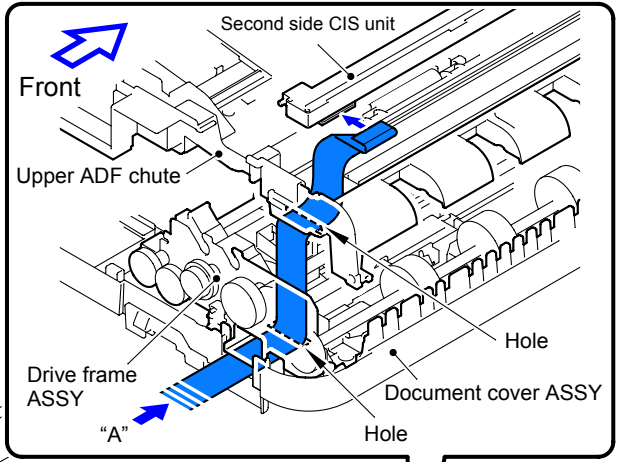
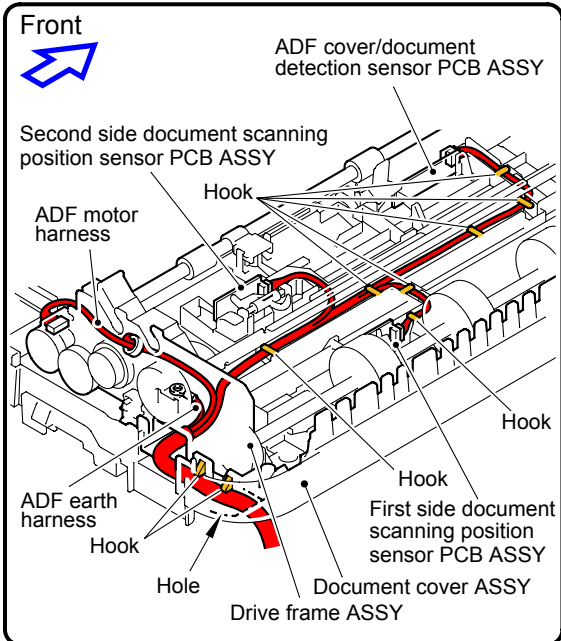

Harness colors may be changed for any reason.

14 ADF (Legal model)

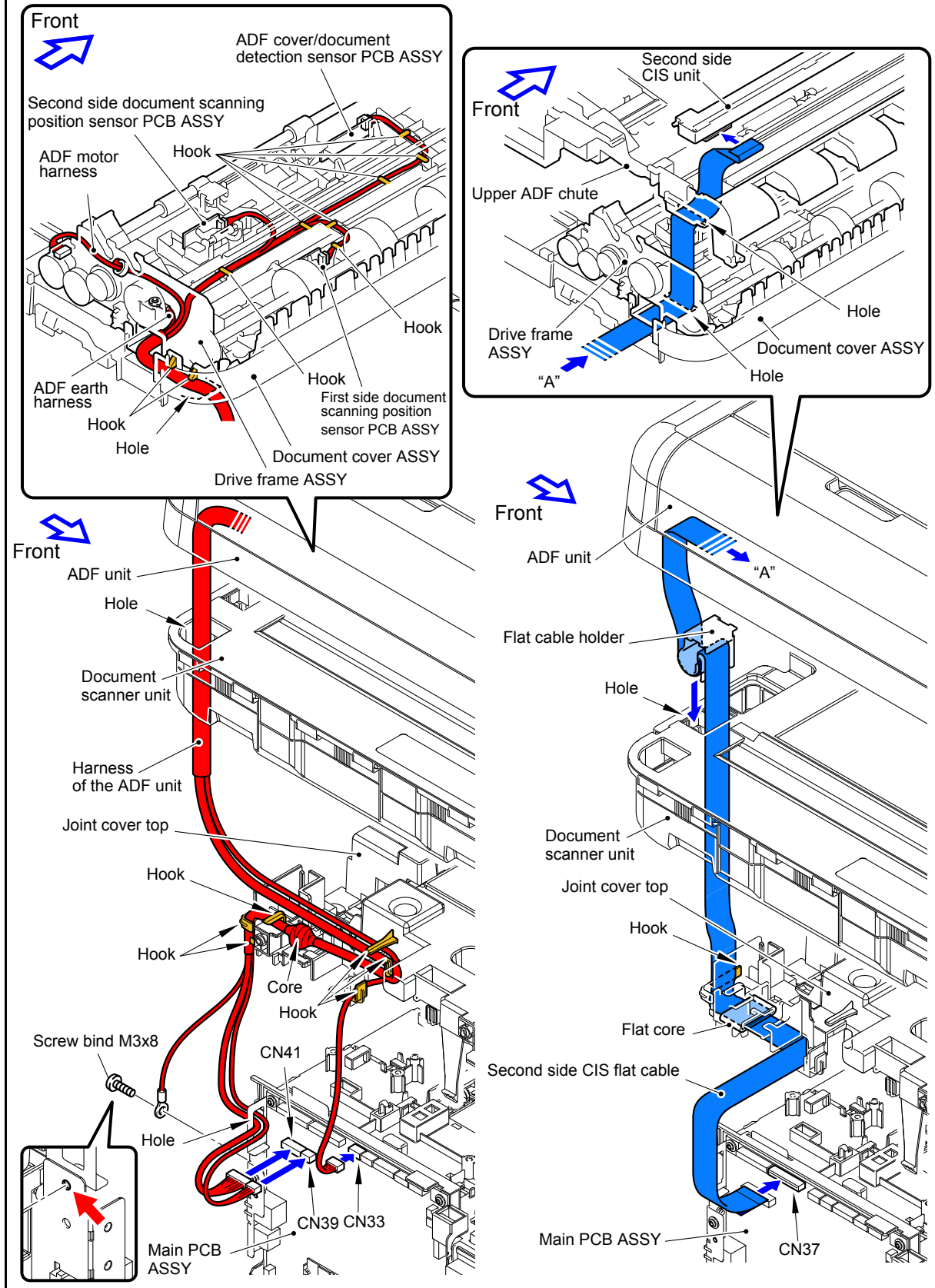

Harness colors may be changed for any reason.

15 Document Scanner Unit (A4 model)

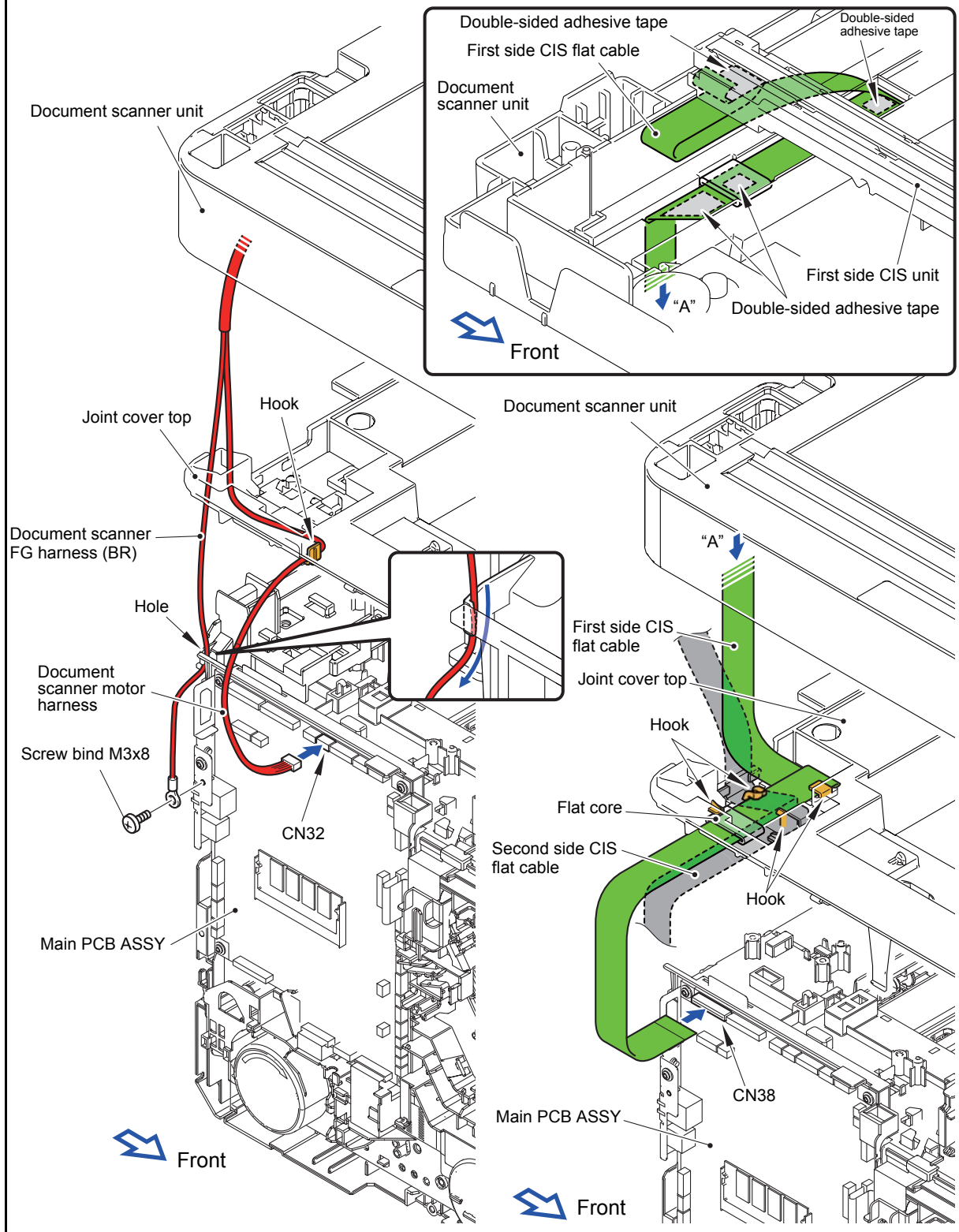

Harness colors may be changed for any reason.

16 Document Scanner Unit (Legal model)

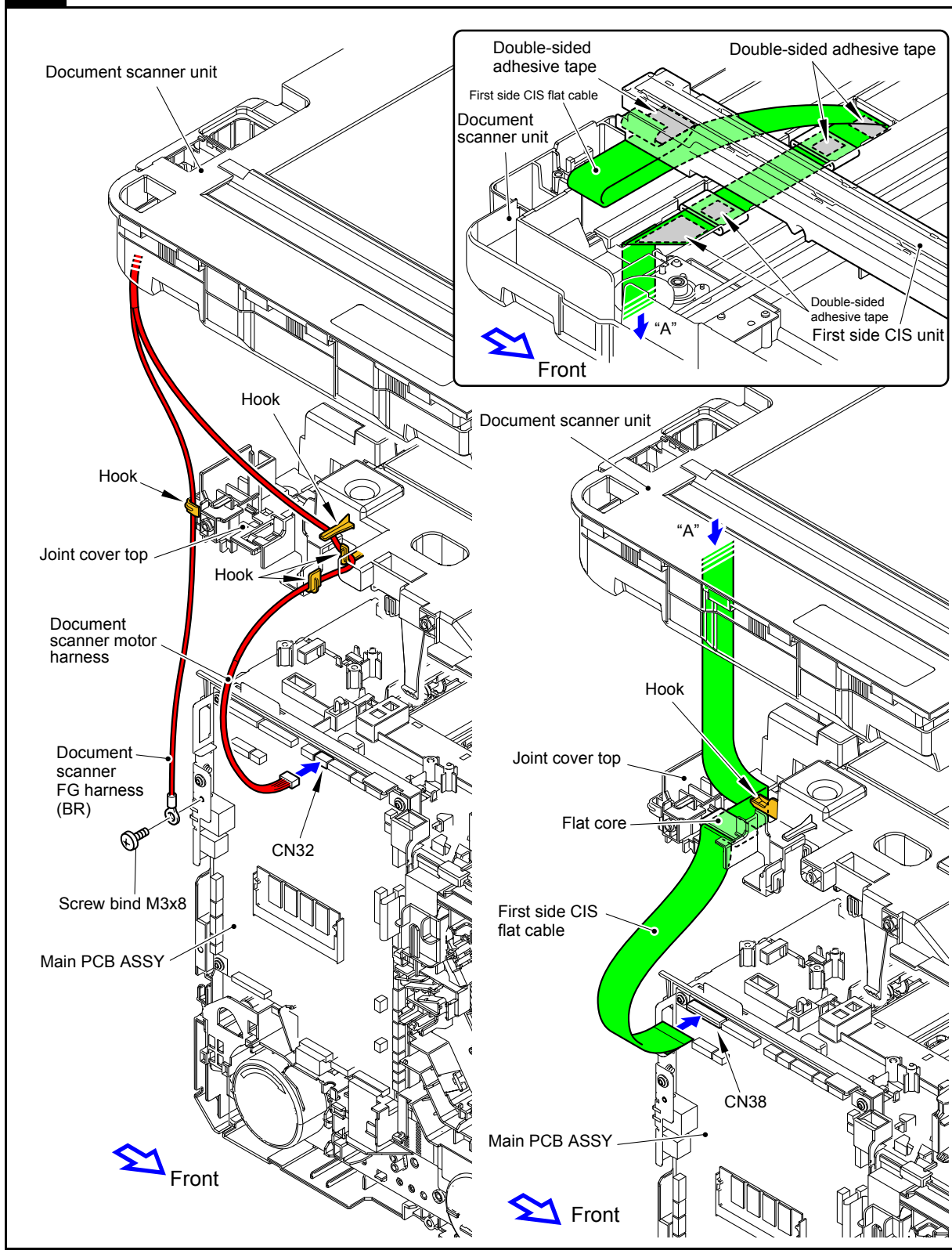

Harness colors may be changed for any reason.

17 Control Panel ASSY (A4 model)

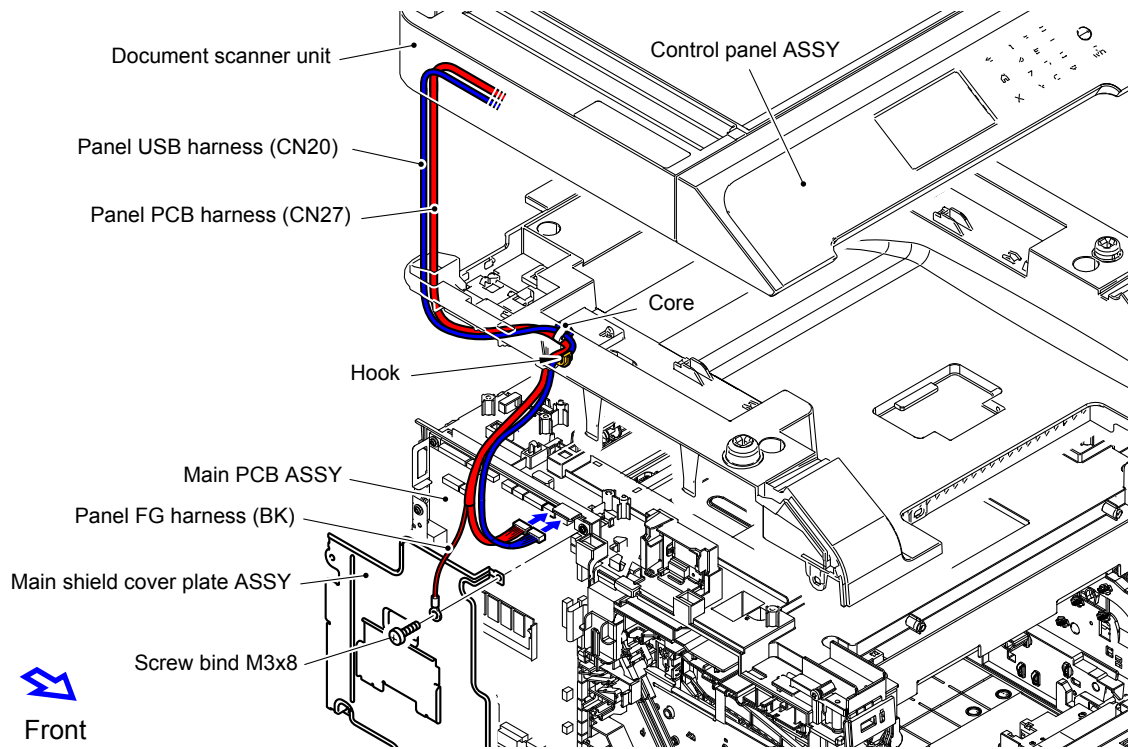

18 Control Panel ASSY (Legal model)

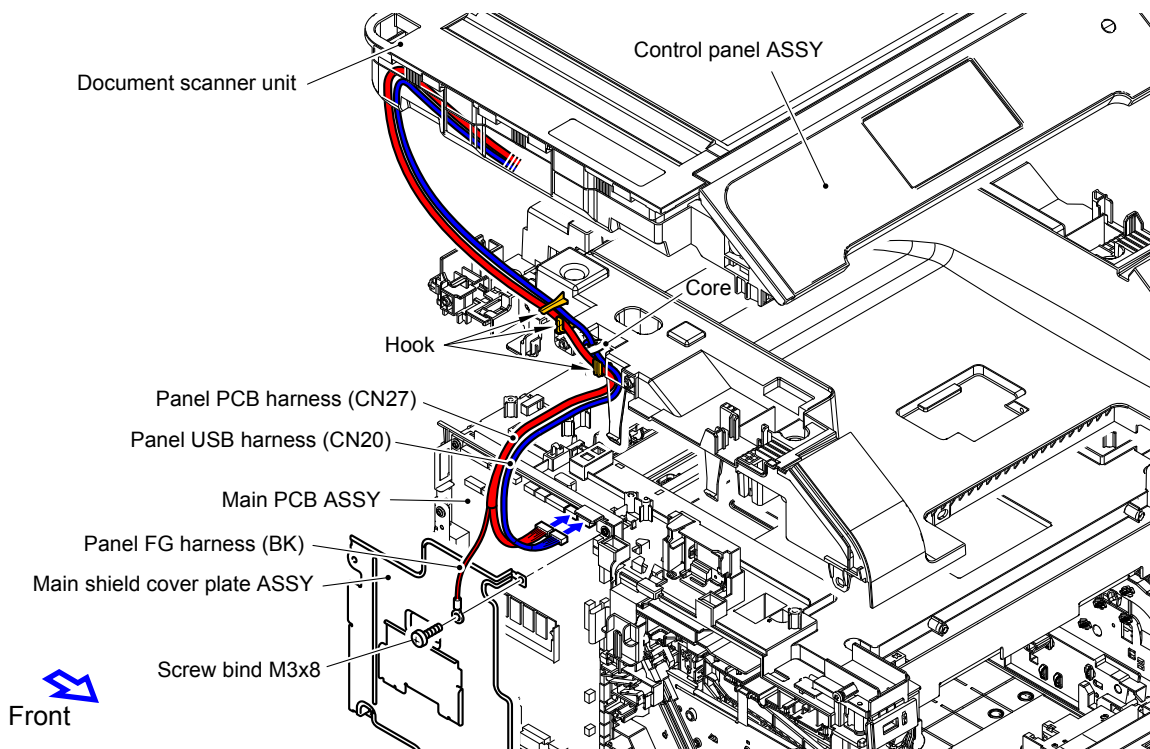

Harness colors may be changed for any reason.

19 Modem PCB ASSY (A4 model)

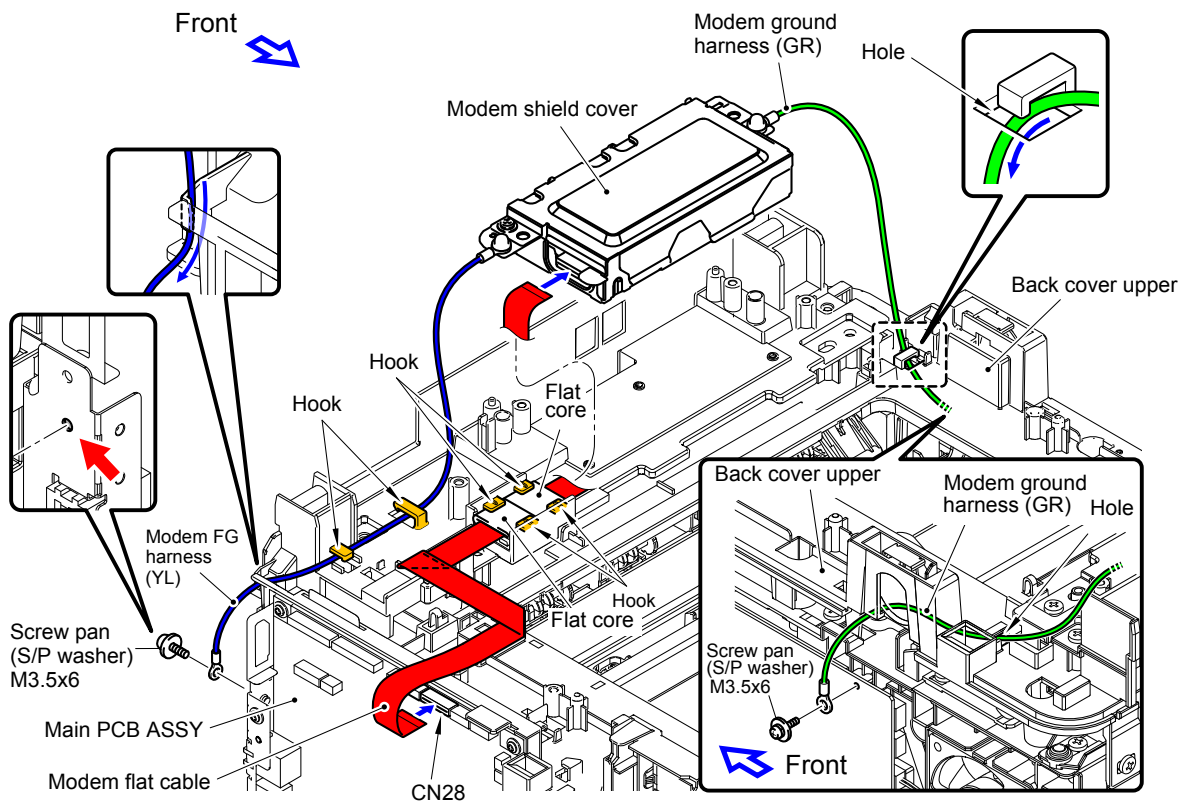

20 Modem PCB ASSY (Legal model)

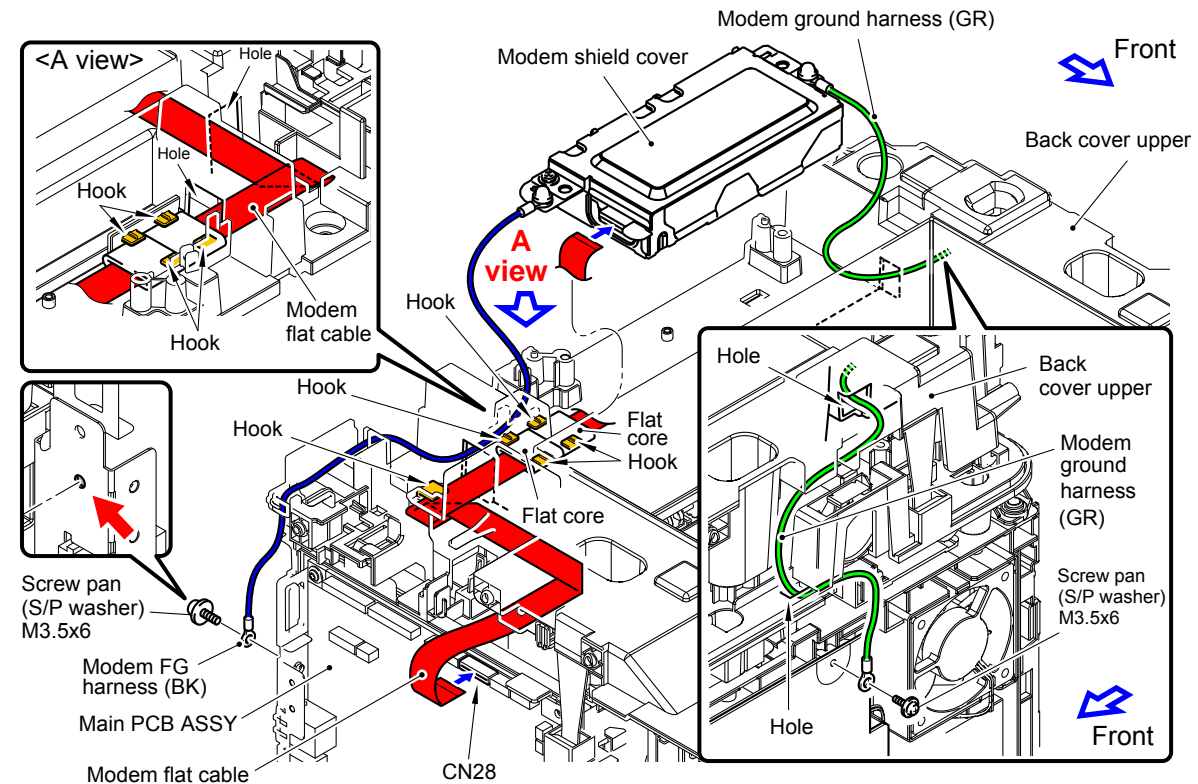

Harness colors may be changed for any reason.

21 USB-Host

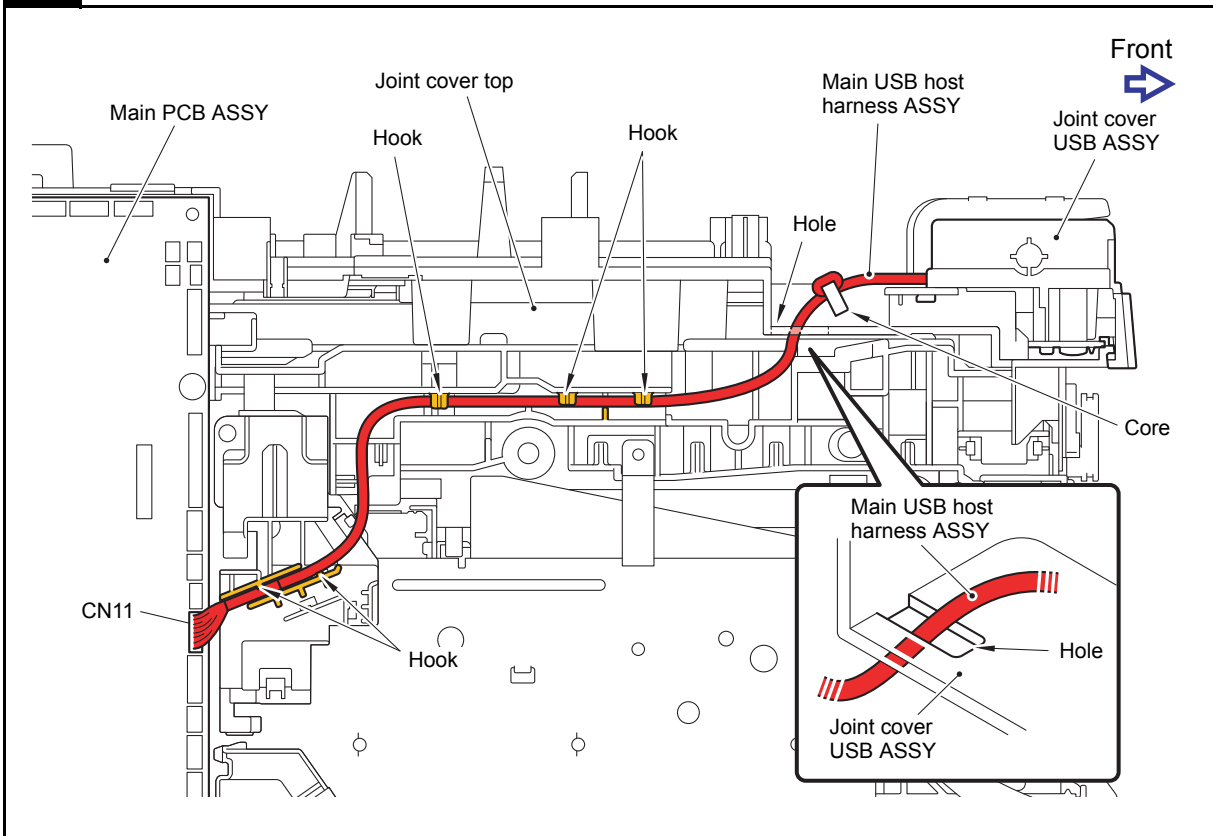

22 Wireless LAN PCB

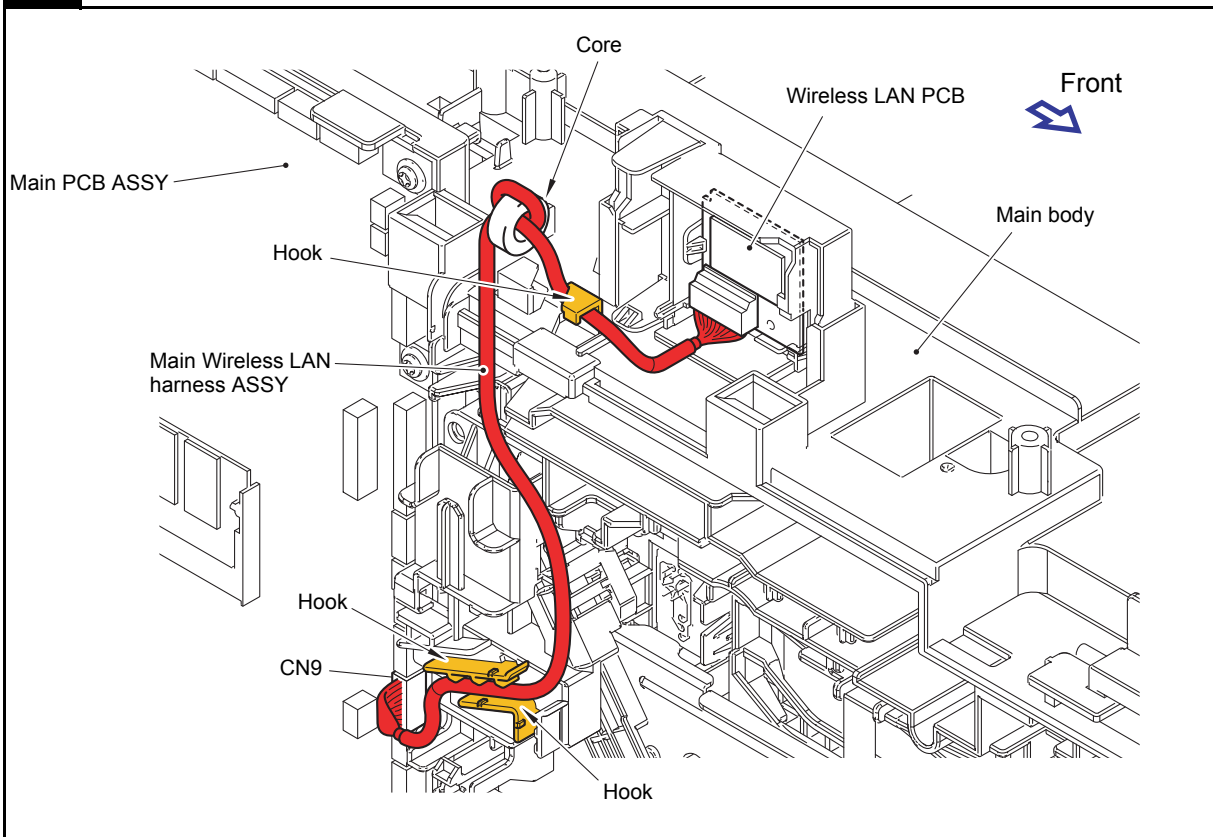

Harness colors may be changed for any reason.

8. DISASSEMBLY FLOW

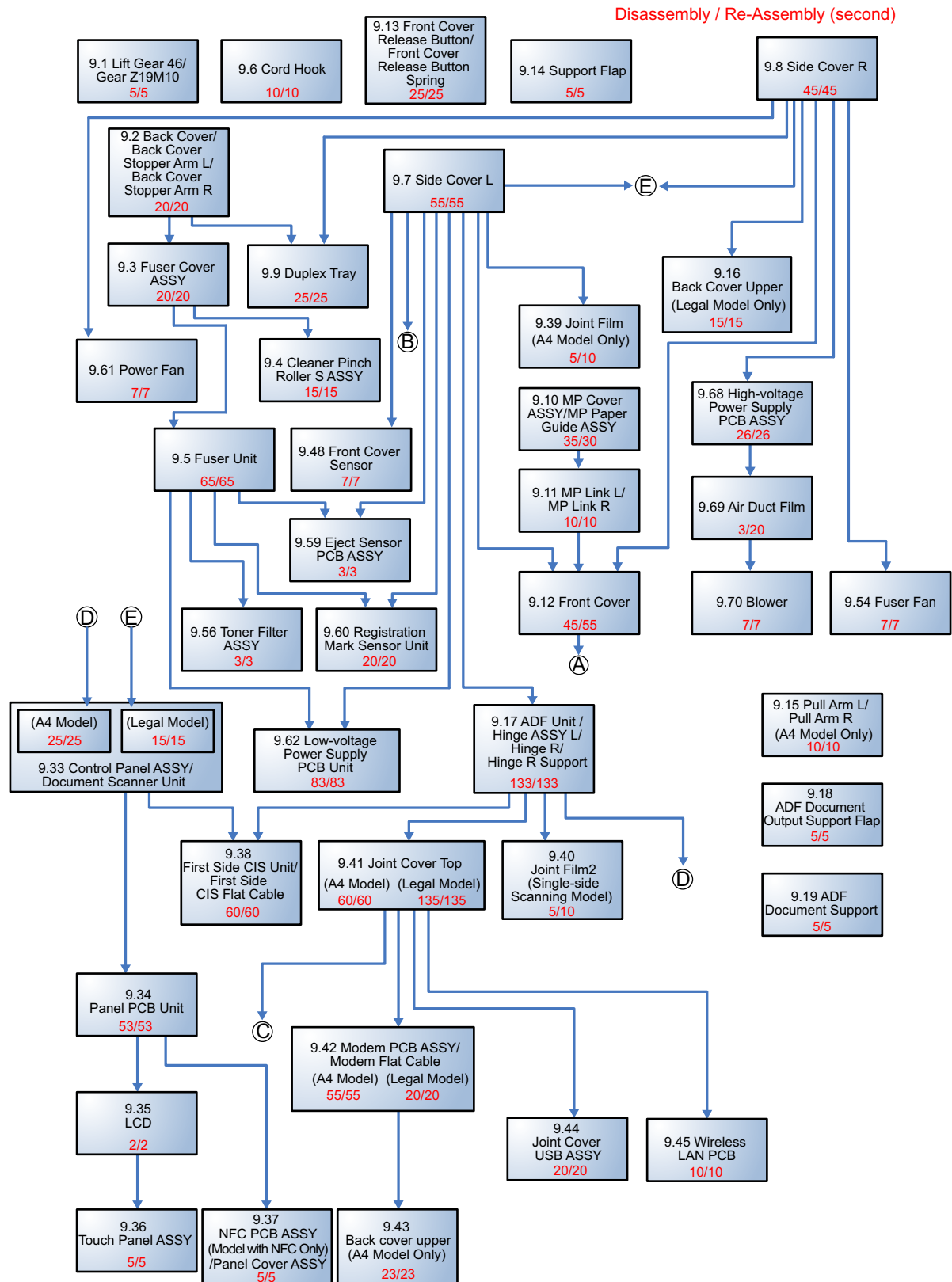

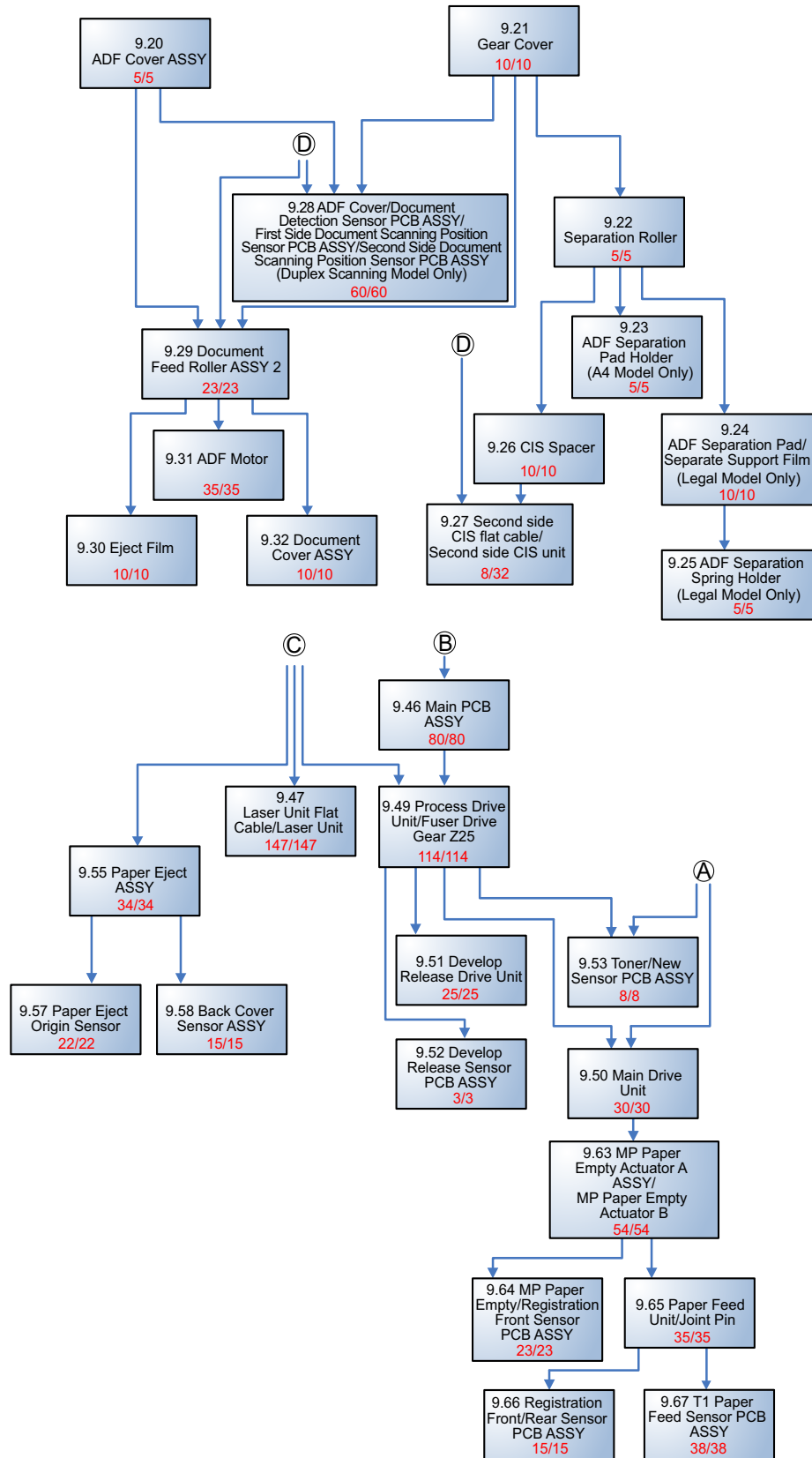

9. DISASSEMBLY PROCEDURE

■ Preparation

Prior to proceeding with the disassembly procedure,

- (1) Unplug
 - the AC cord,
 - the telephone line,
 - the USB cable, if connected,
 - the LAN cable, if connected, and
 - USB flash memory drive, if connected.
- (2) Remove
 - the Paper tray,
 - the Toner cartridge,
 - the Drum unit,
 - the Belt unit,
 - the Waste toner box,
 - EXT cap, and
 - LAN port cap.

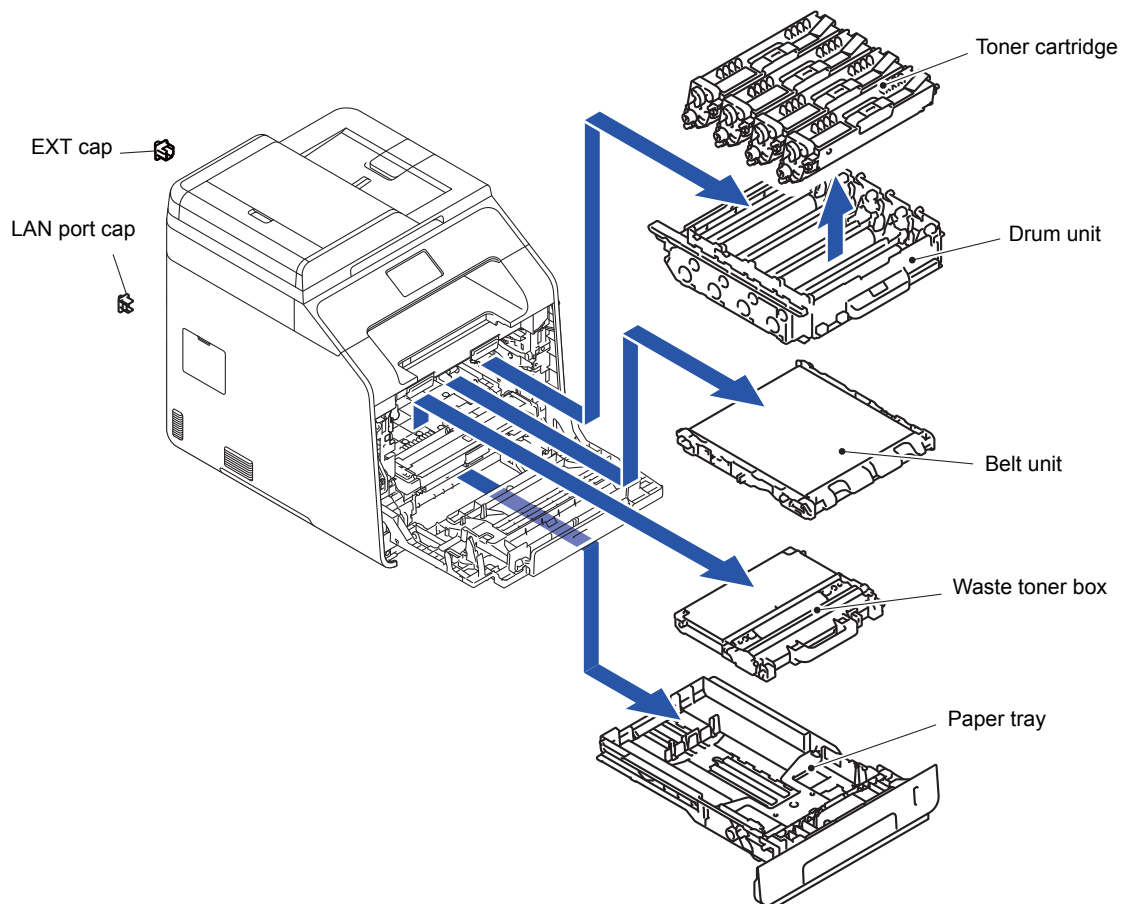

Note: Backup of machine information

Before starting disassembly work, back up the machine information and user setting information. (Refer to [“1.3.13 Backup of machine information \(Function code 41\)”](#) in [Chapter 5](#).) After replacing the PCB, restore the backup data to a new PCB.

9.1 Lift Gear 46/Gear Z19M10

(1) Lift up the Plate. Release the Hook and remove the Lift gear 46 from the Plate up plate.

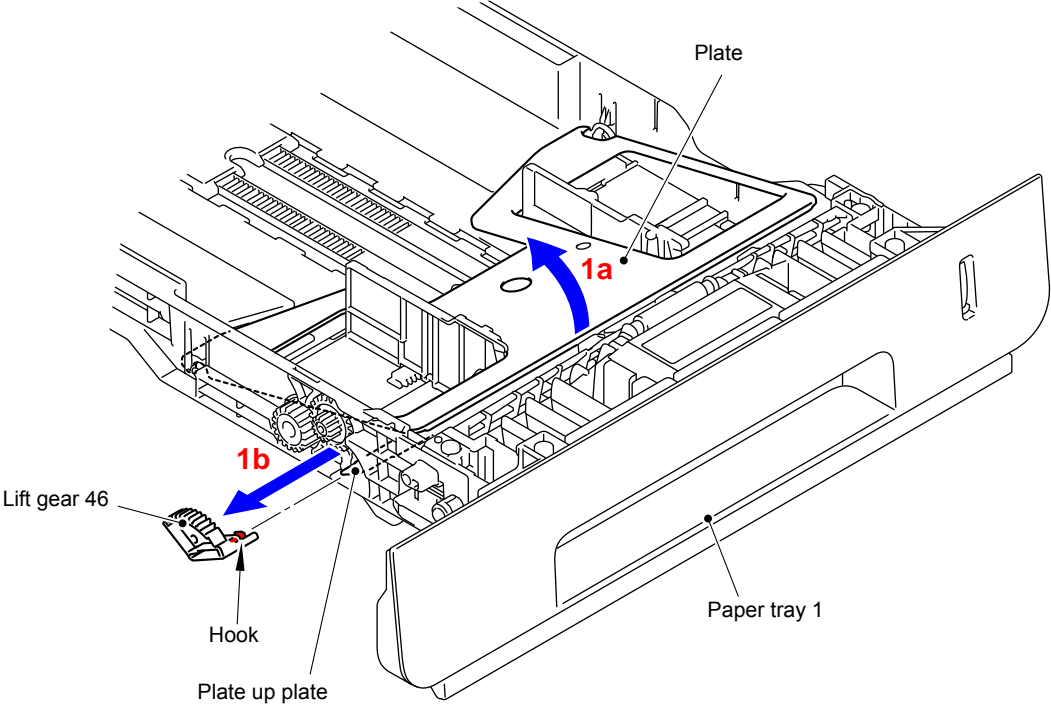

Fig. 3-1

(2) Remove the Gear Z24M10Z14M75 from the Paper tray 1.

(3) Remove the Gear Z19M10 from the Paper tray 1.

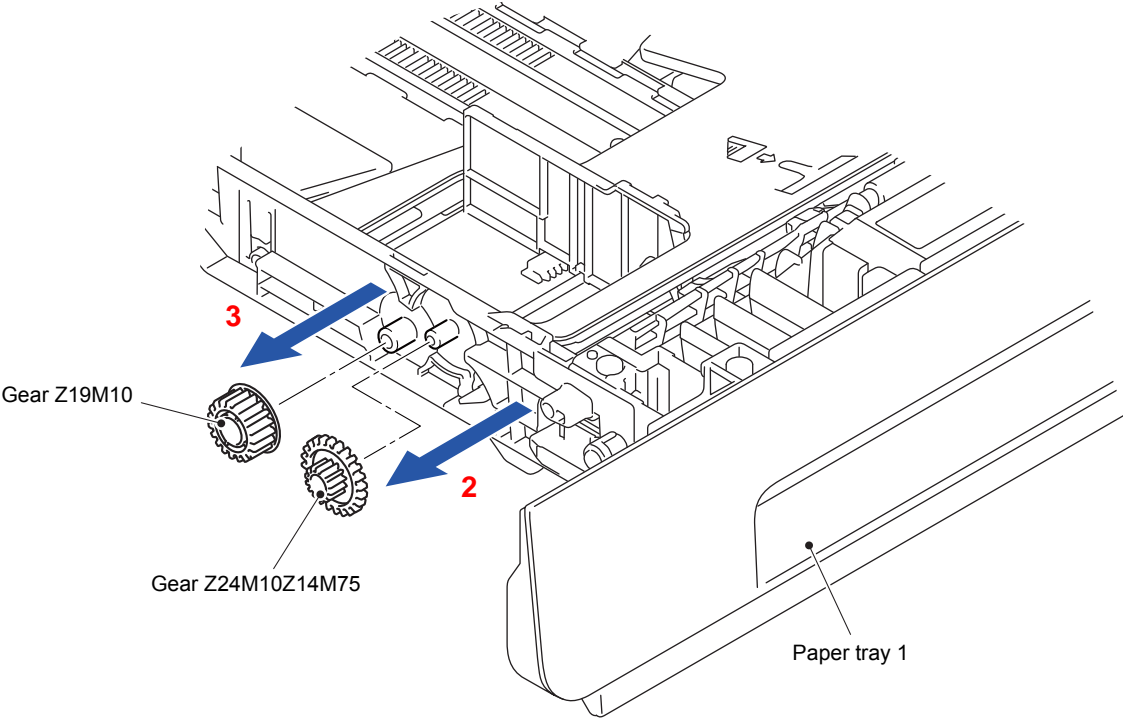

Fig. 3-2

9.2 Back Cover/Back Cover Stopper Arm L/ Back Cover Stopper Arm R

(1) Open the Back cover.

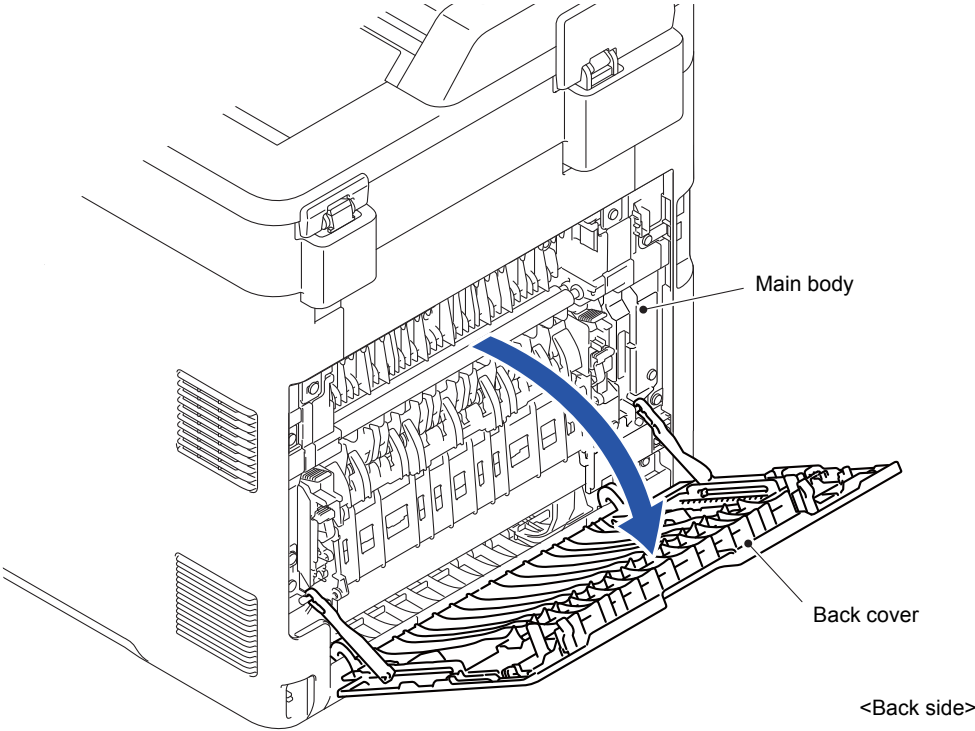

Fig. 3-3

(2) Remove the Back cover stopper arm L/R from the Main body.

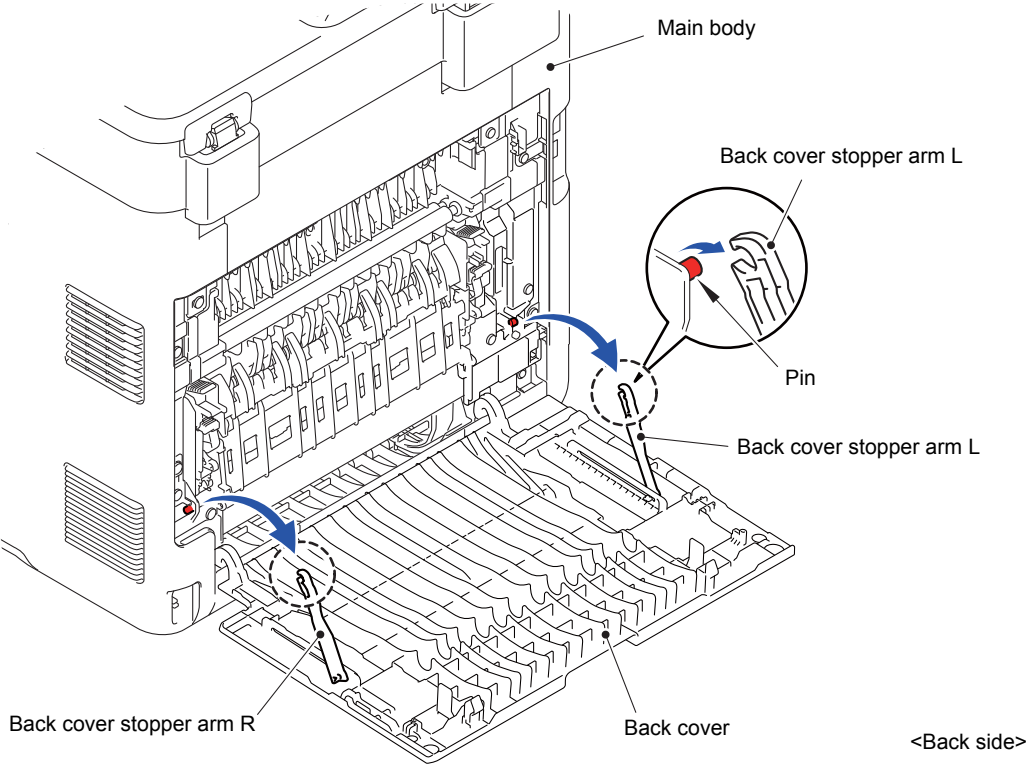

Fig. 3-4

(3) Remove the Shaft of the Back cover from the Bush on the right side of the Main body.

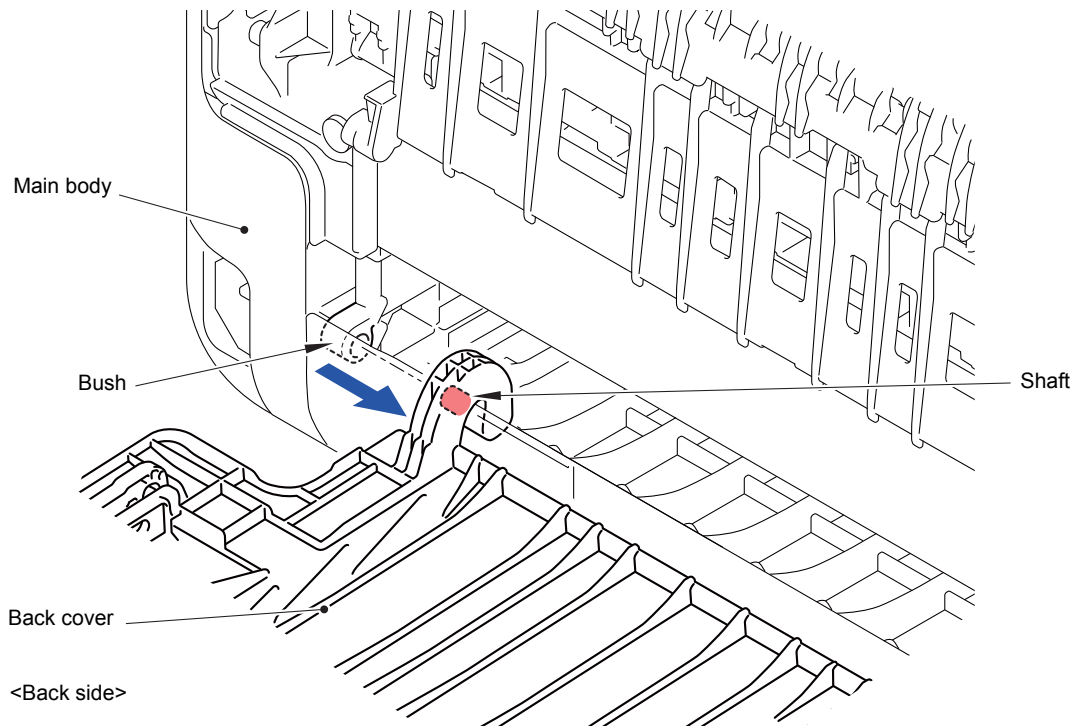

Fig. 3-5

(4) Remove the Back cover.

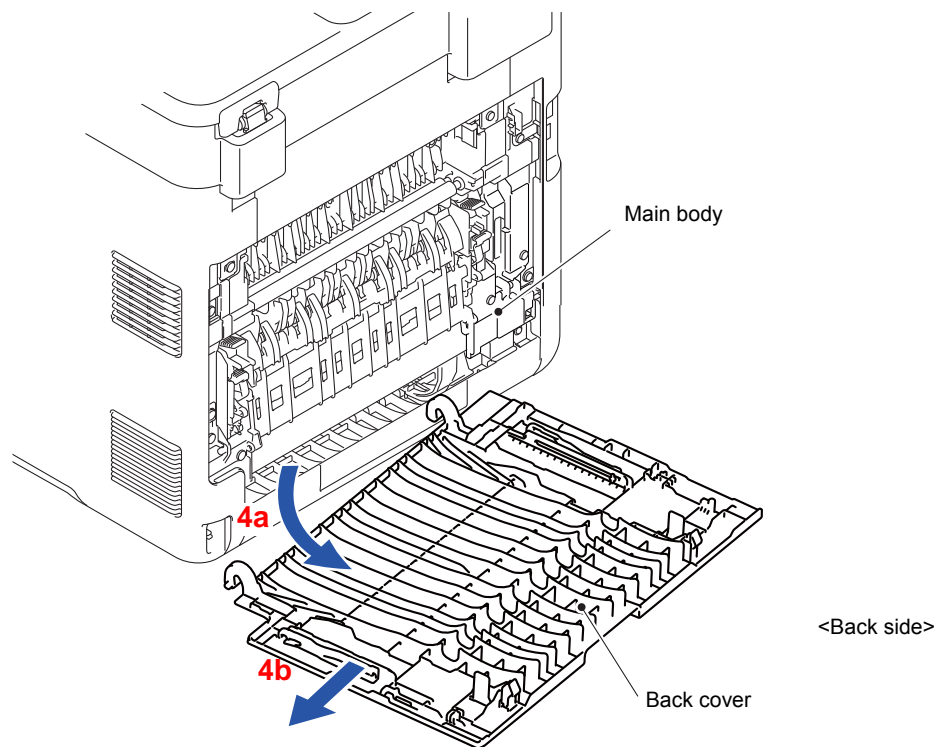

Fig. 3-6

- (5) Remove the Back cover stopper arm L from the Back cover.
- (6) Remove the Back cover stopper arm R from the Back cover.

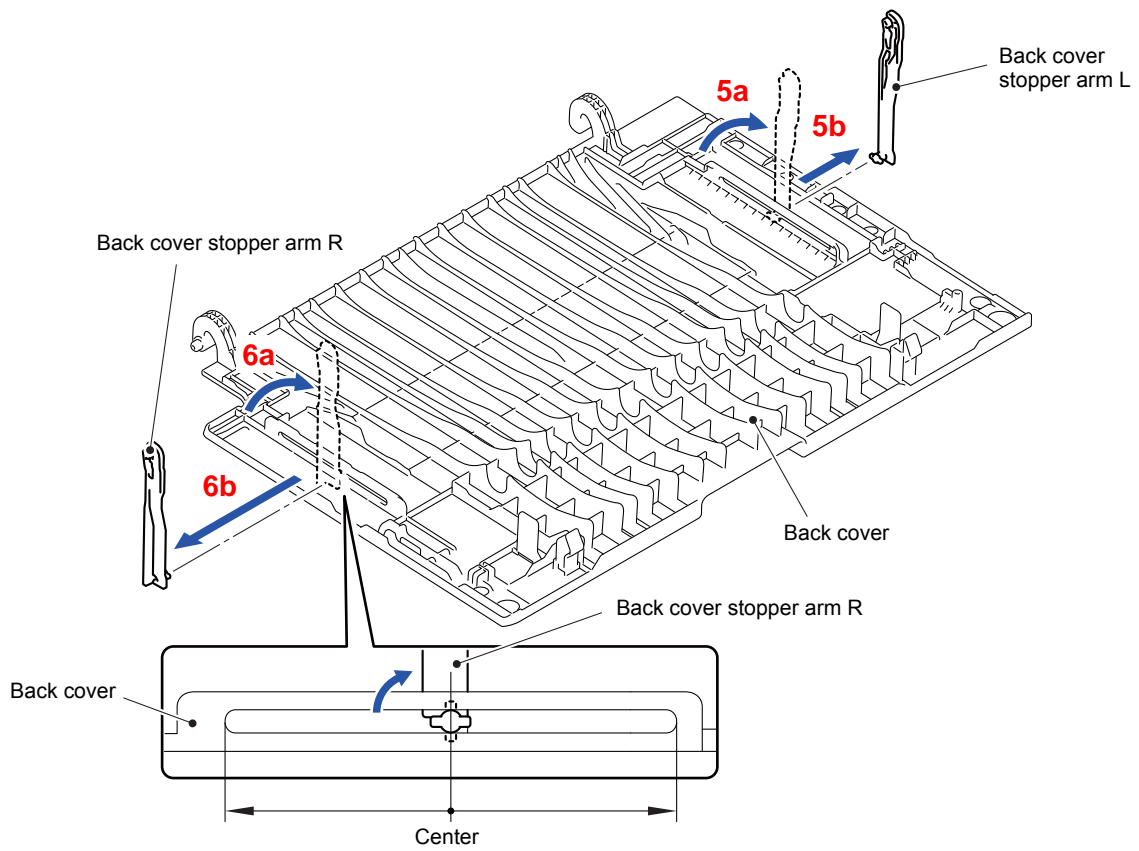

Fig. 3-7

9.3 Fuser Cover ASSY

- (1) Open the Back flapper holder.
Release the two Pins and remove the Back flapper holder from the Main body.

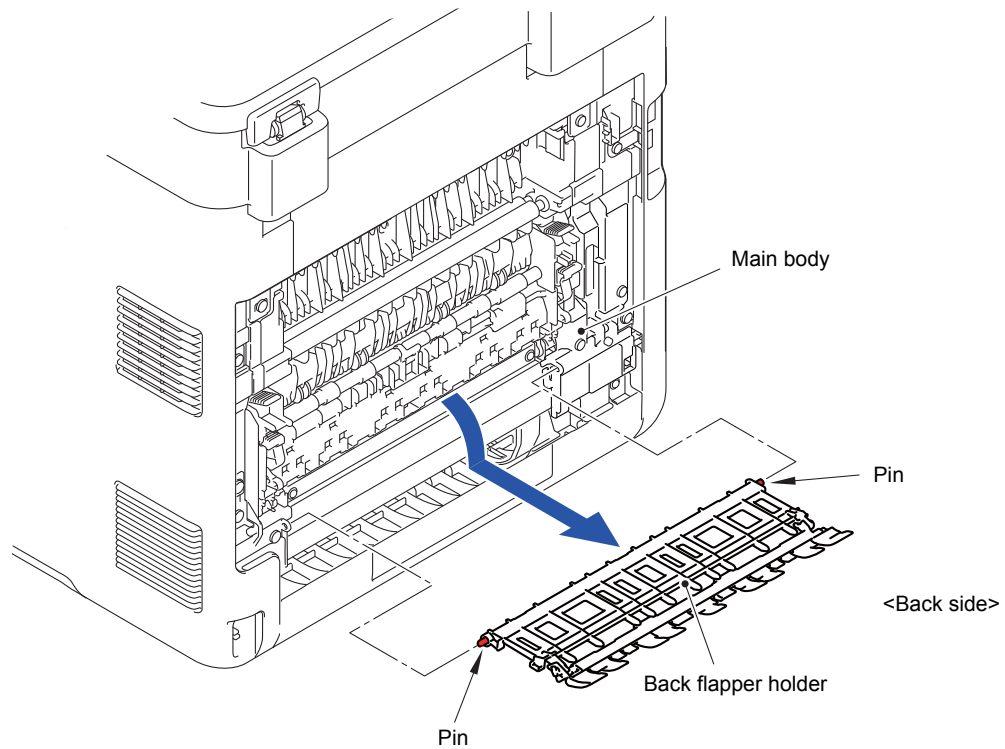

Fig. 3-8

- (2) Remove the two Taptite bind B M4x12 screws from the Fuser cover L.
- (3) Release the one Hook and one Pin and remove the Fuser cover L from the Main body.

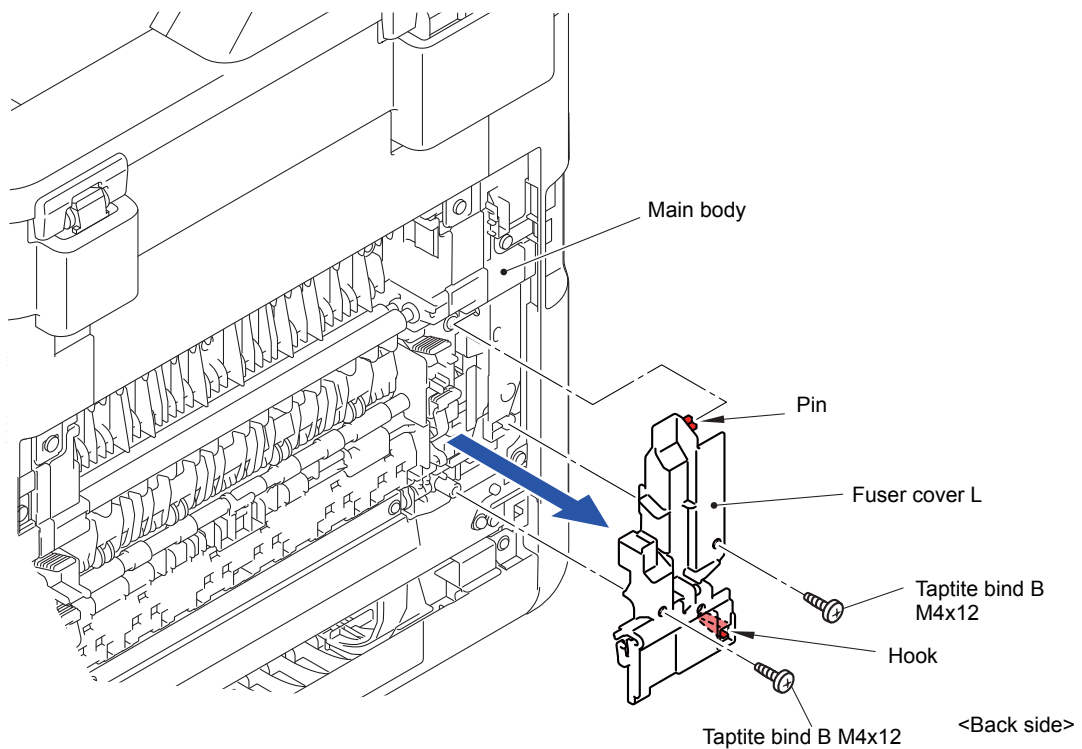

Fig. 3-9

(4) Release the lock of the Fuser cover lock lever L/R to open the Fuser cover ASSY.

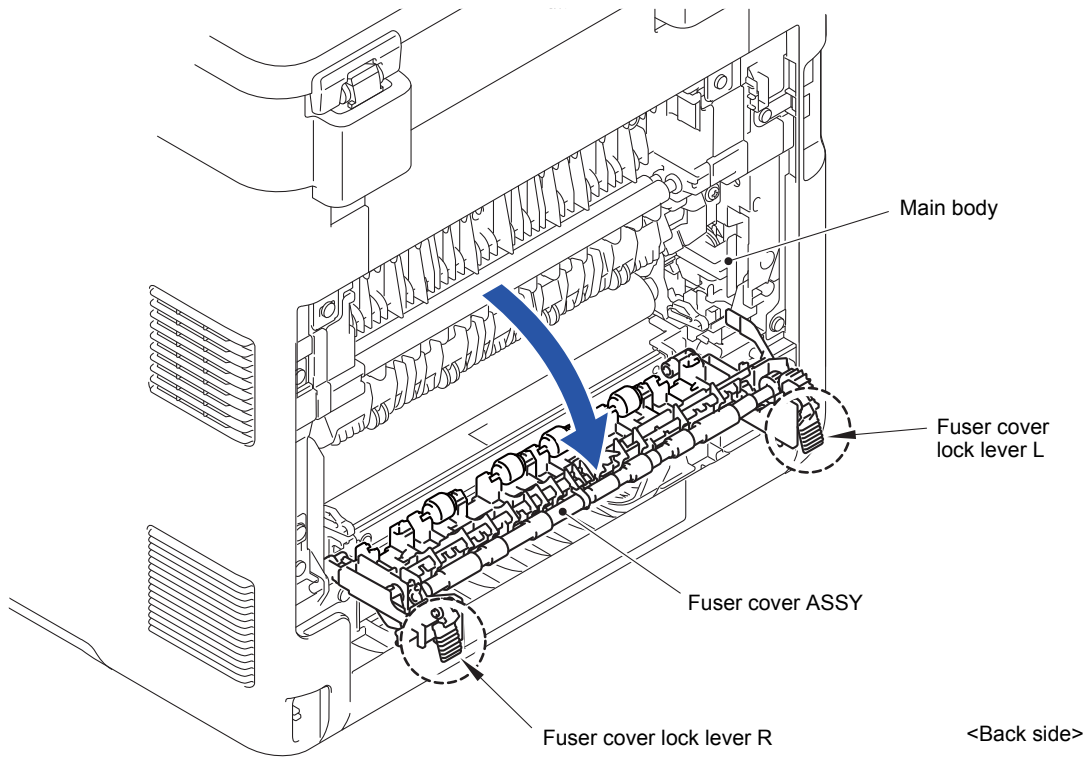

Fig. 3-10

(5) Slide the Fuser cover ASSY in the direction of the arrow 5a and remove it to the front.

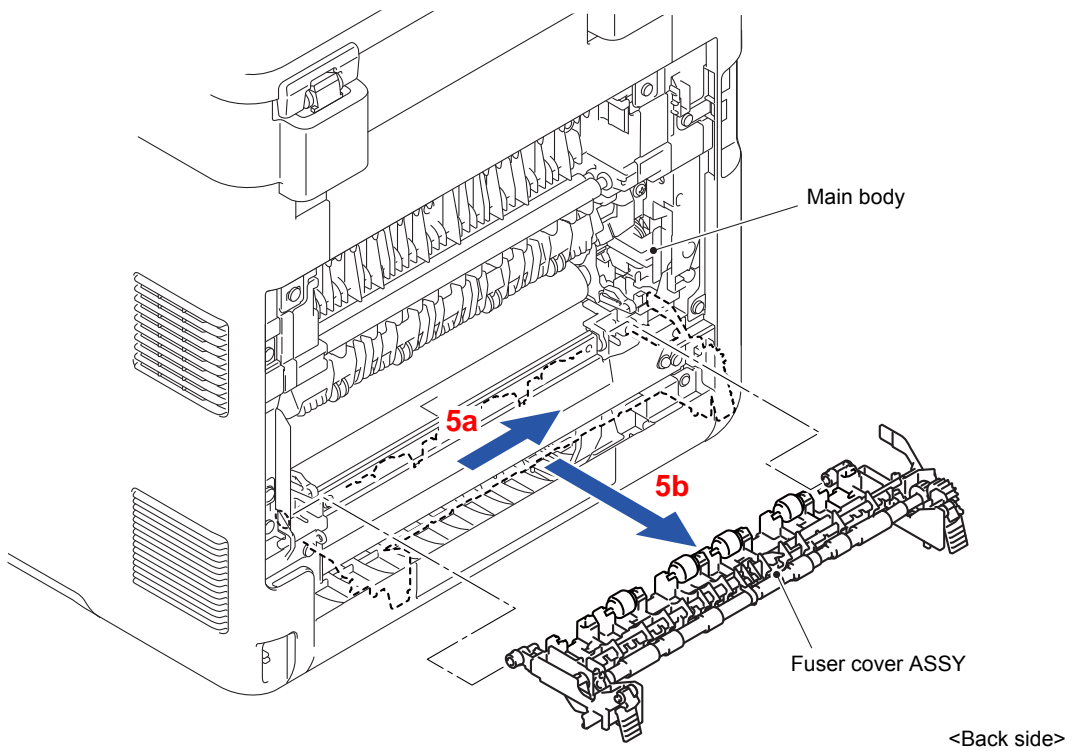

Fig. 3-11

9.4 Cleaner Pinch Roller S ASSY

(1) Remove the Cleaner roller spring from the Hook of the Fuser cover ASSY.

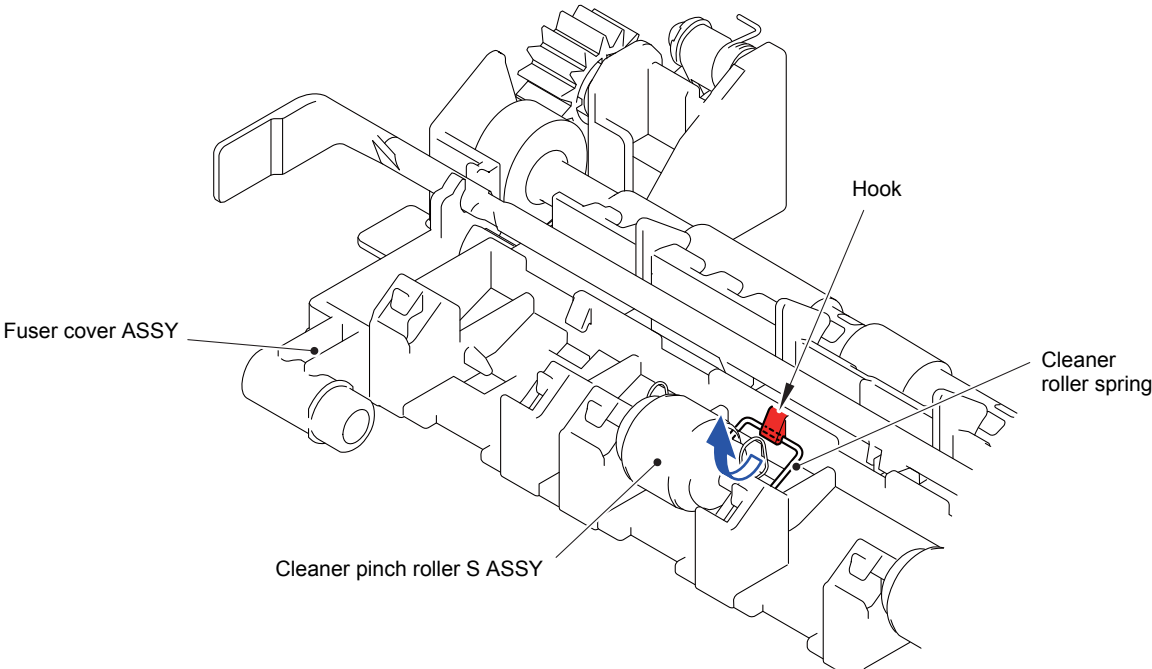

Fig. 3-12

(2) Remove the Cleaner roller spring from the two Pins of the Fuser cover ASSY. Remove the Cleaner pinch roller S ASSY and Cleaner roller spring from the Fuser cover ASSY.

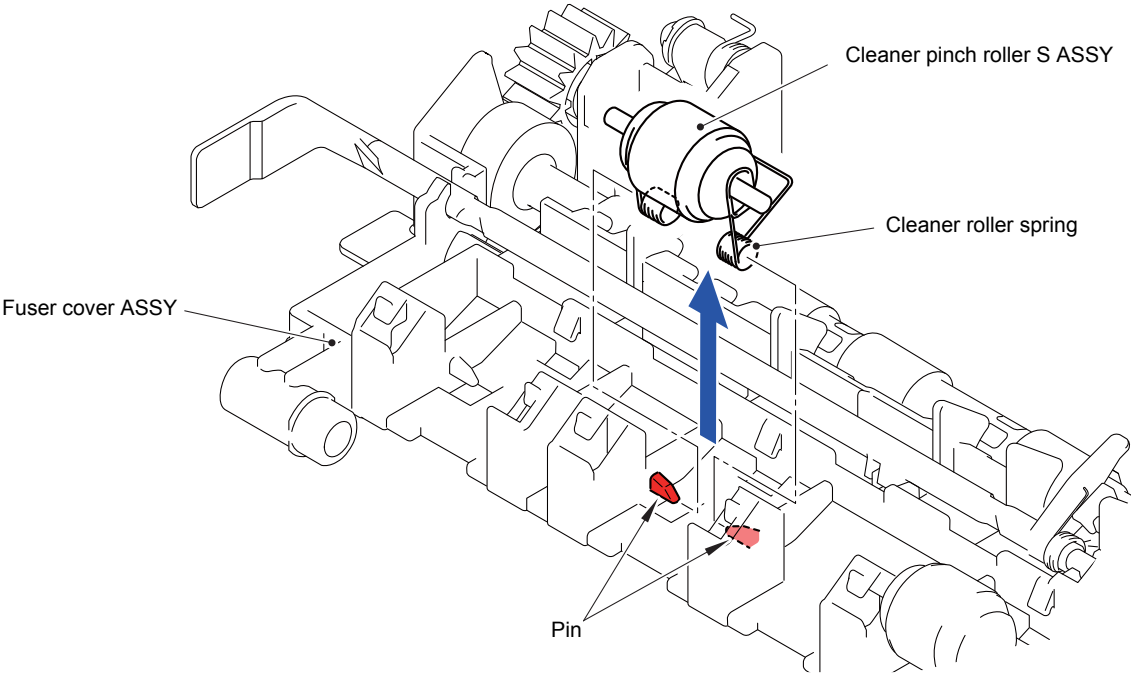

Fig. 3-13

(3) Remove the Cleaner pinch roller S ASSY from the Cleaner roller spring.

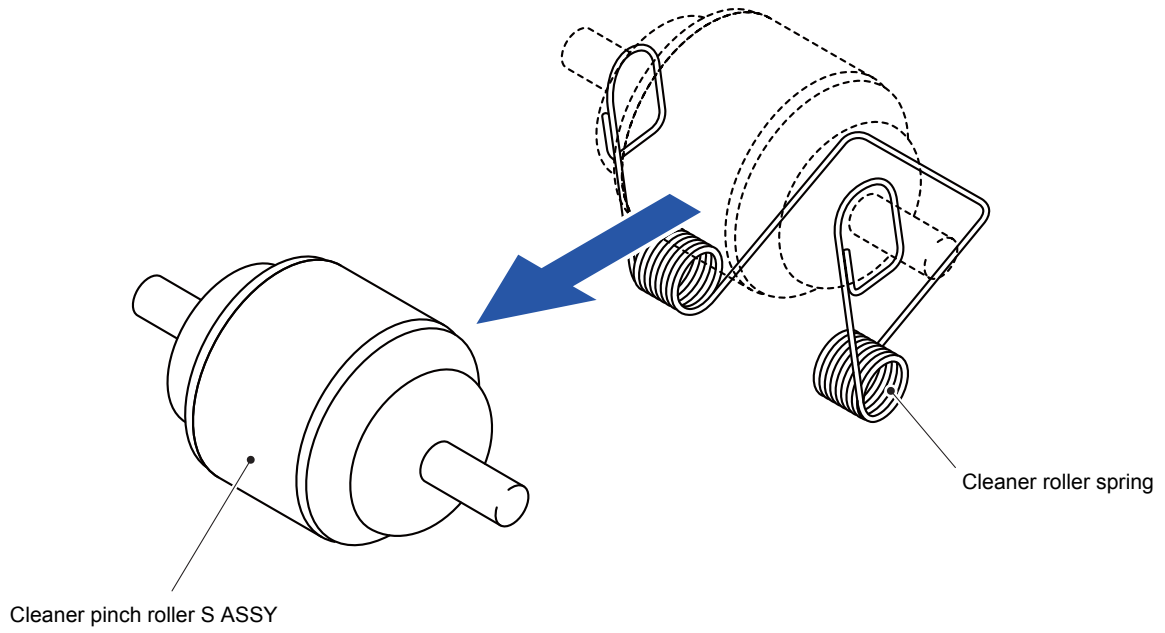

Fig. 3-14

(4) Remove the other three Cleaner pinch roller S ASSYs in the same way.

9.5 Fuser Unit

- (1) Remove the two Taptite bind B M4x12 screws from the Fuser cover R.
- (2) Release the two Hooks and remove the Fuser cover R from the Main body.

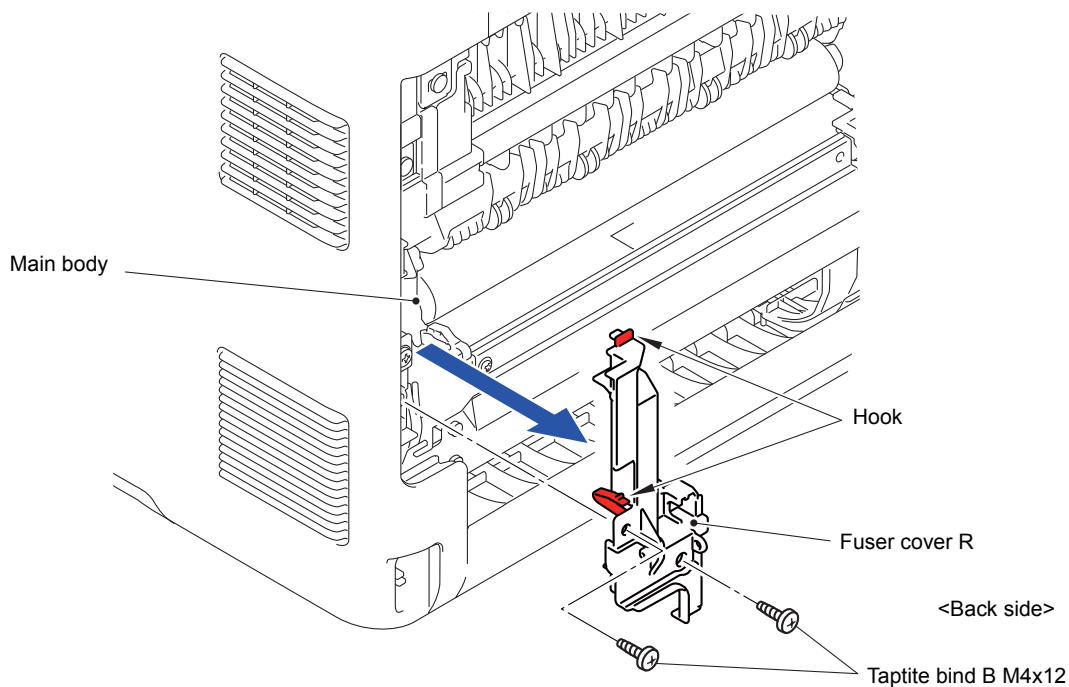

Fig. 3-15

- (3) Disconnect the two Connectors (CN1 and CN2) from the Eject sensor PCB ASSY.

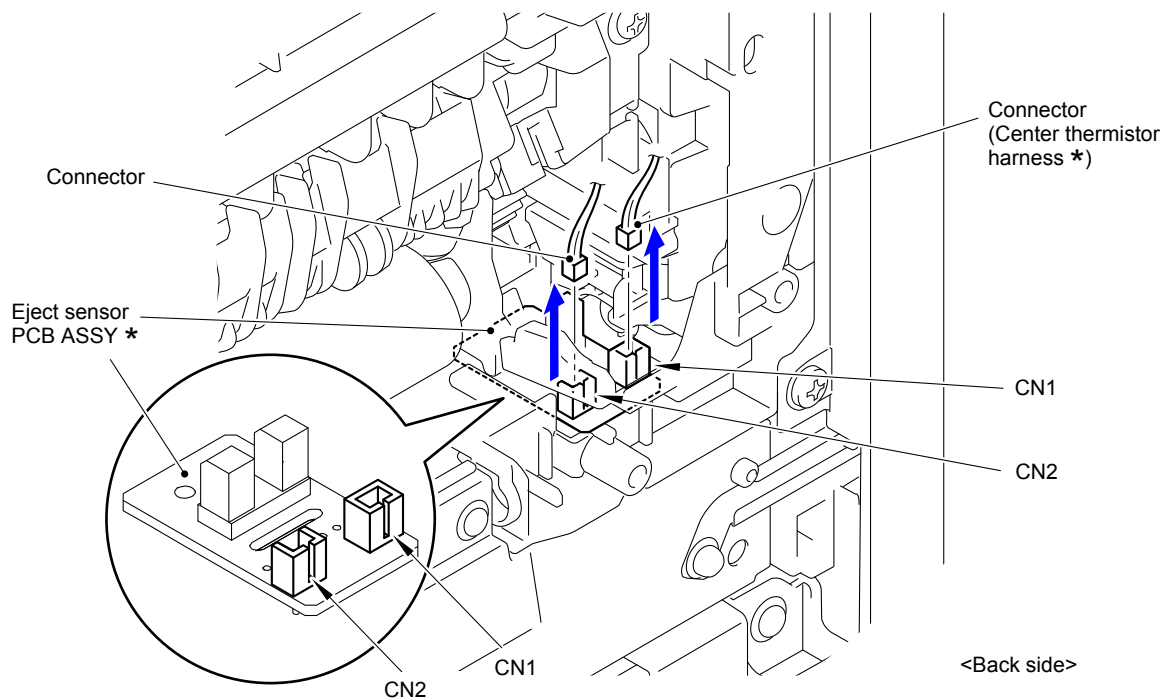

Fig. 3-16

Assembling Note:

- * Center thermistor has a black and blue connectors (230V models only). The black connector may be connected to the blue insertion port and vice versa.

- (4) Disconnect the Electrode terminal of the Main body from the Electrode terminal of the Fuser unit.

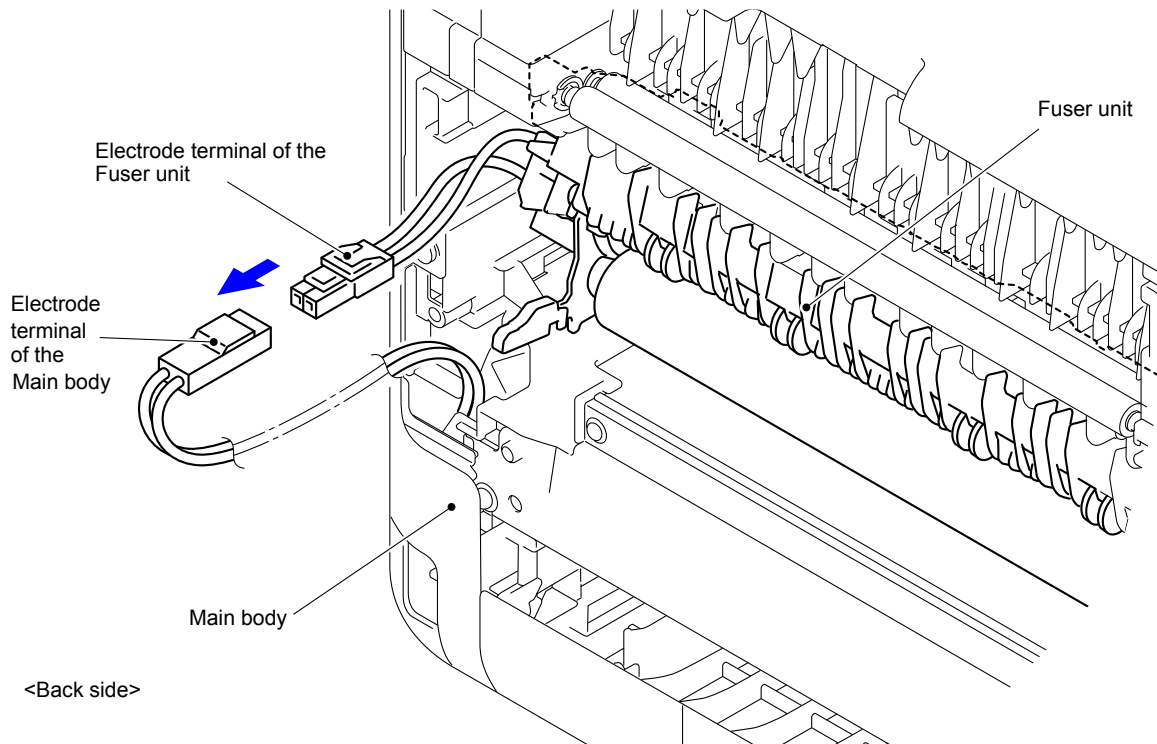

Fig. 3-17

- (5) Remove the two Taptite pan B M4x14 screws to remove the Fuser unit from the Main body.

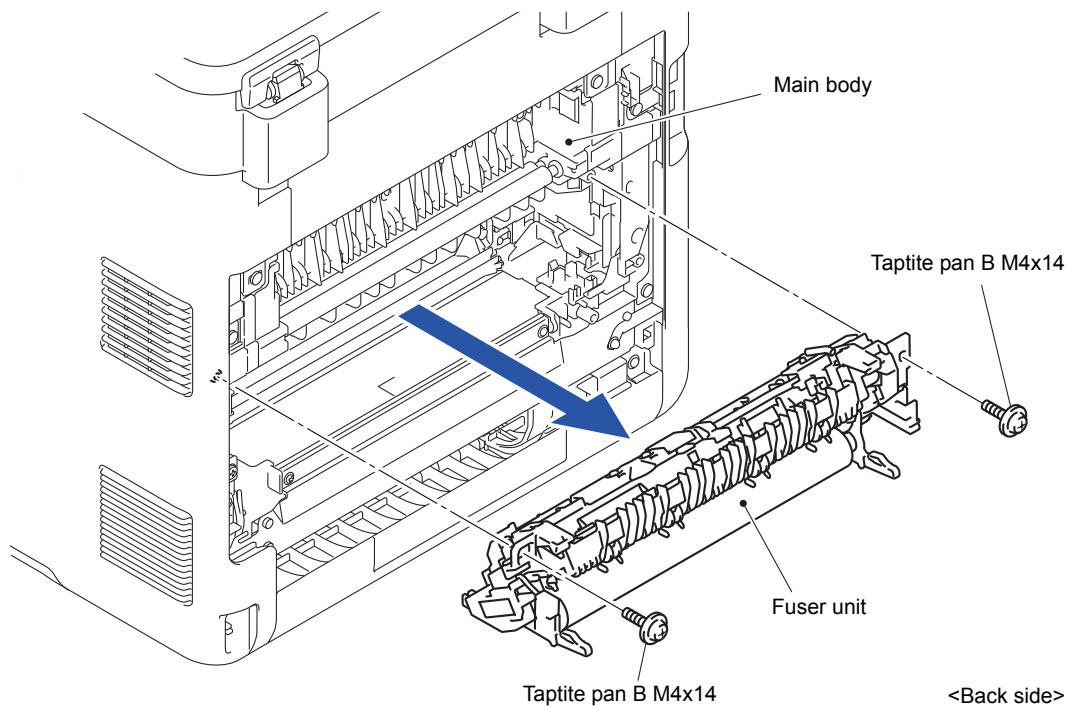

Fig. 3-18

Note:

- Do not apply a physical impact or vibration to the Fuser unit.
- Do not touch the roller and electrodes as shown in the figure below to prevent breakage of the Fuser unit.

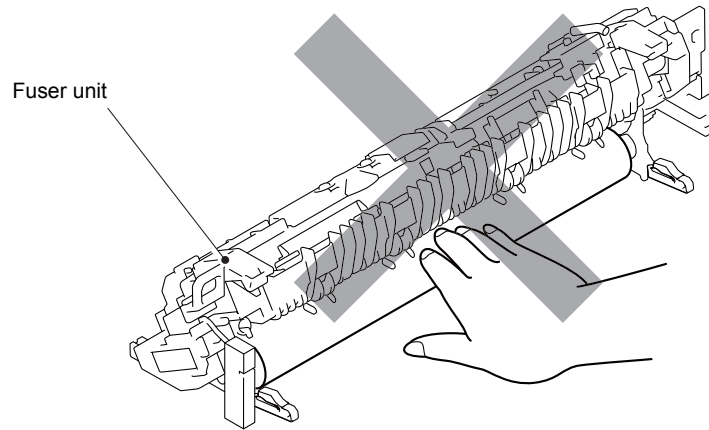

Fig. 3-19

Harness routing: Refer to “ [6 Eject Sensor PCB ASSY, Fuser Unit](#)”

9.6 Cord Hook

(1) Rotate the Cord hook in the direction of the arrow 1a and remove it from the Main body.

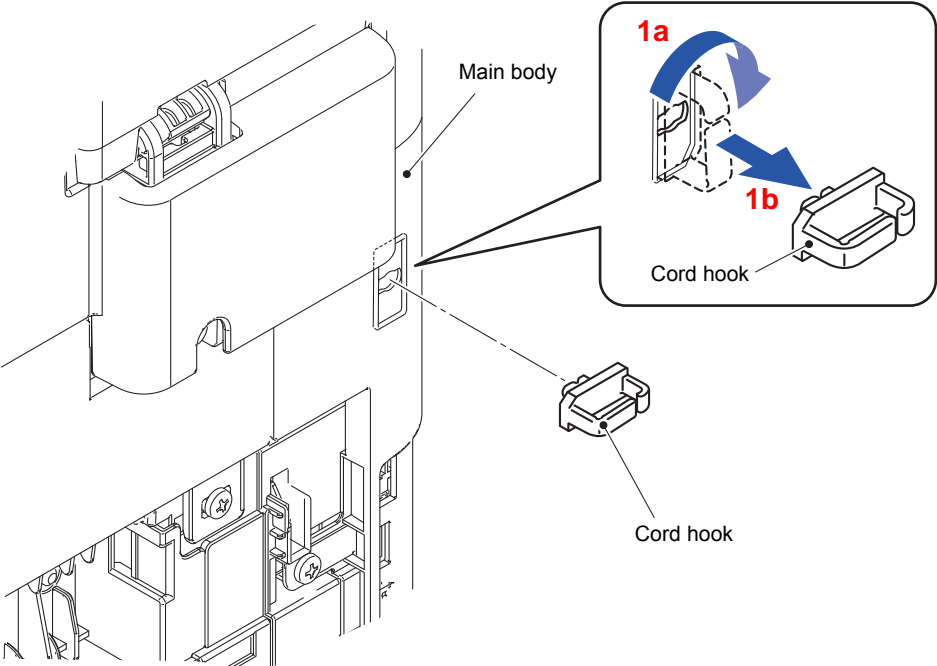

Fig. 3-20

(2) Remove the other Cord hook in the same way.

9.7 Side Cover L

(1) Open the Front cover.

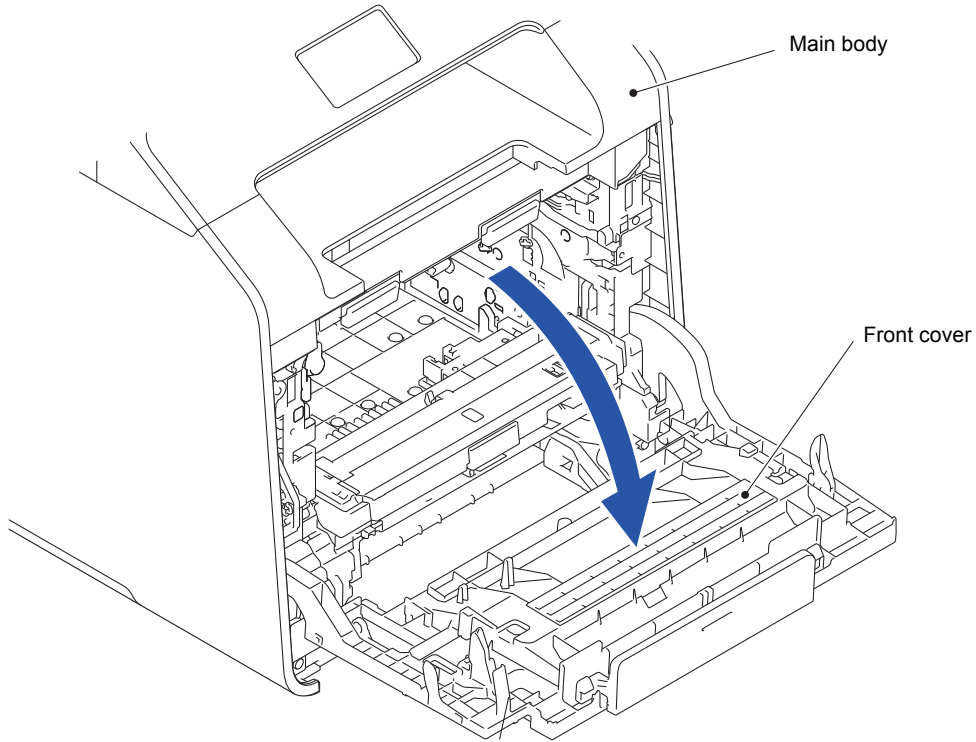

Fig. 3-21

- (2) Remove the one Taptite B 3x6 screw and the one Taptite bind B M4x12 screw from the front of the Side cover L.
- (3) Remove the Taptite bind B M4x12 screw from the side of the Side cover L.

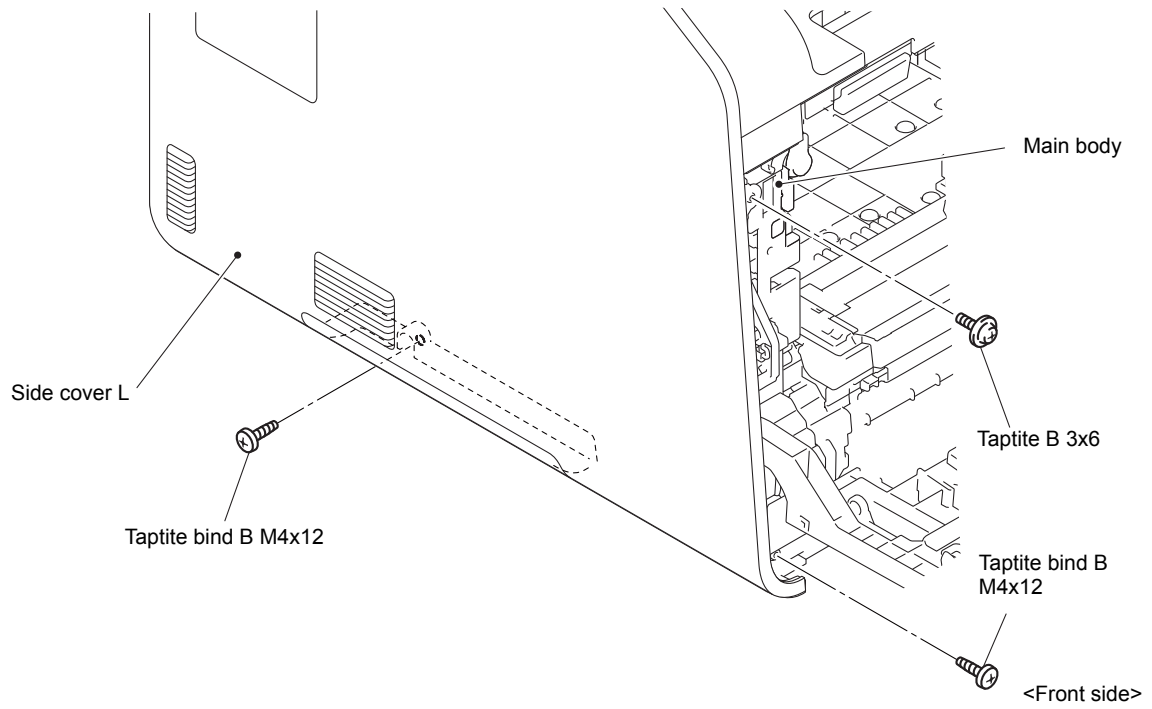

Fig. 3-22

(4) Remove the two Taptite bind B M4x12 screws from the back of the Side cover L.

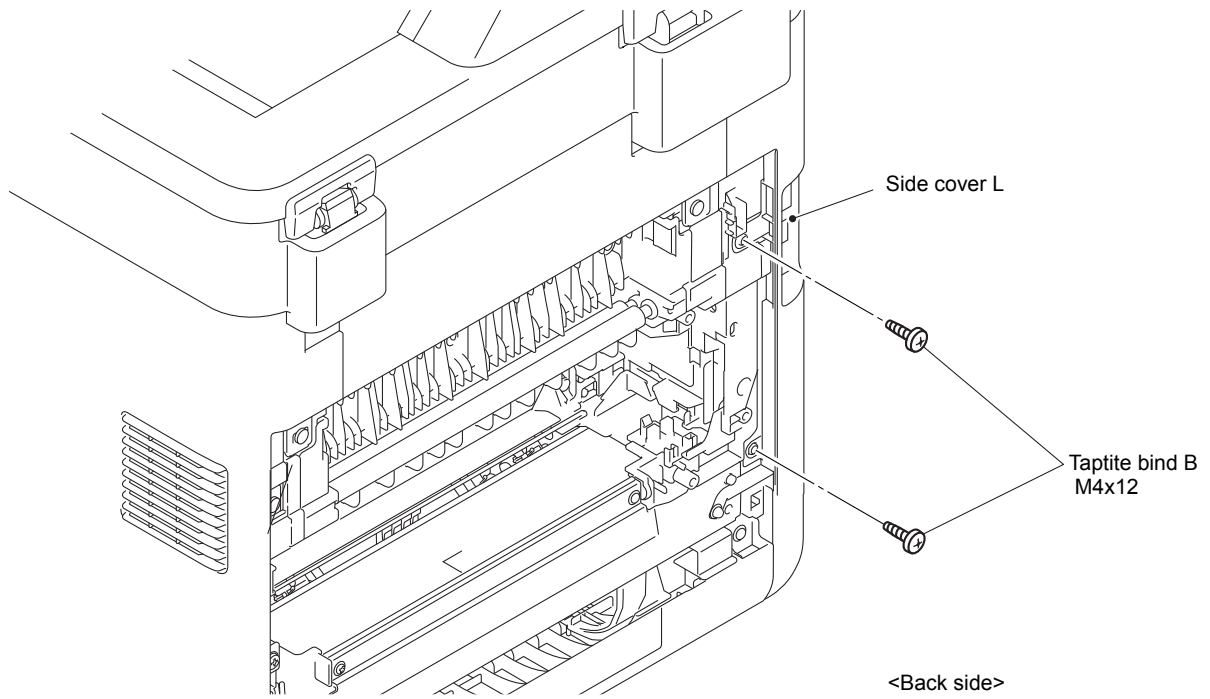

Fig. 3-23

■ **A4 model**

- (5) Release the Hooks 1 to 8 in numerical order. Move the Side cover L in the direction of the arrow 5a and release the other Hooks and remove Side cover L from the Main body.

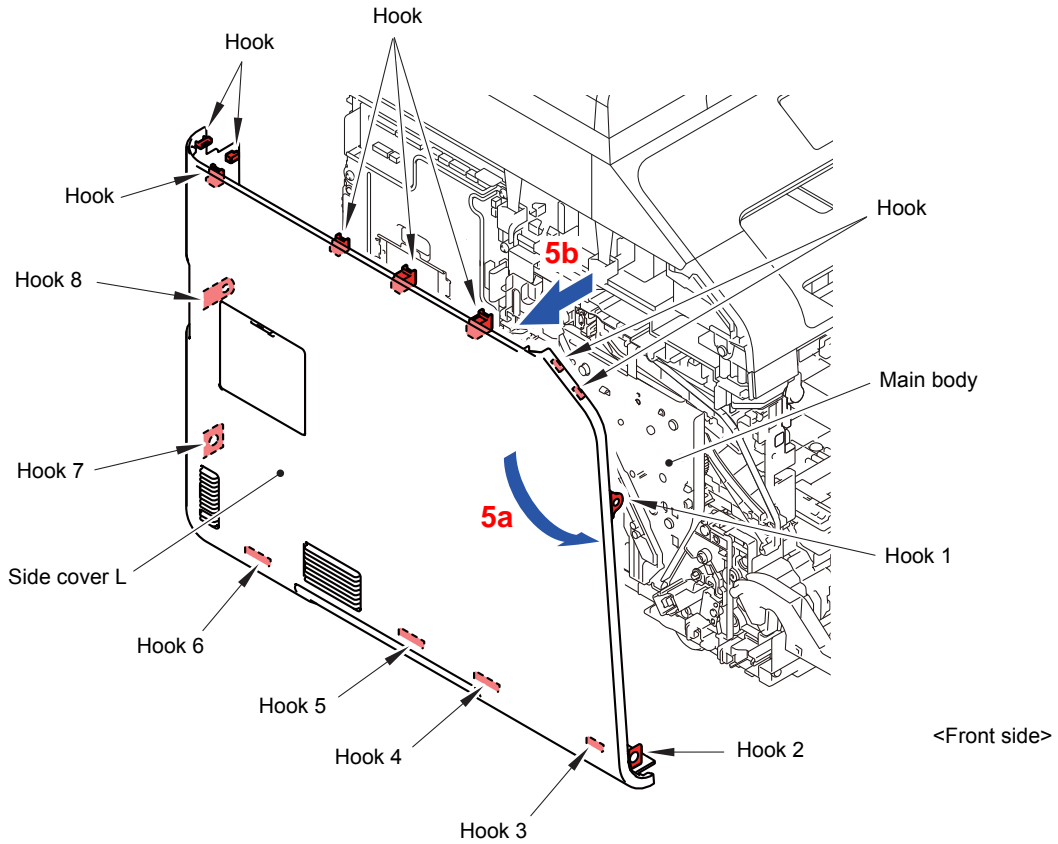

Fig. 3-24

* Inside of Side cover L

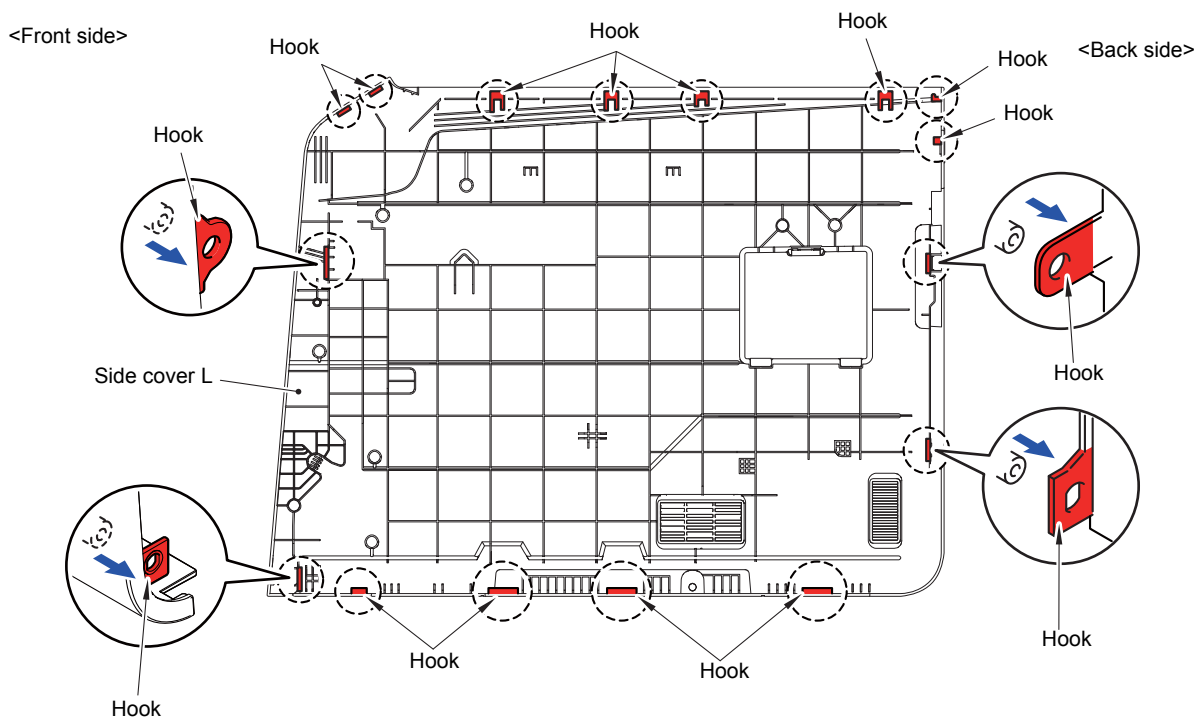

Fig. 3-25

■ Legal model

- (5) Release the Hooks 1 to 8 in numerical order. Move the Side cover L in the direction of the arrow 5a and release the other Hooks and remove Side cover L from the Main body.

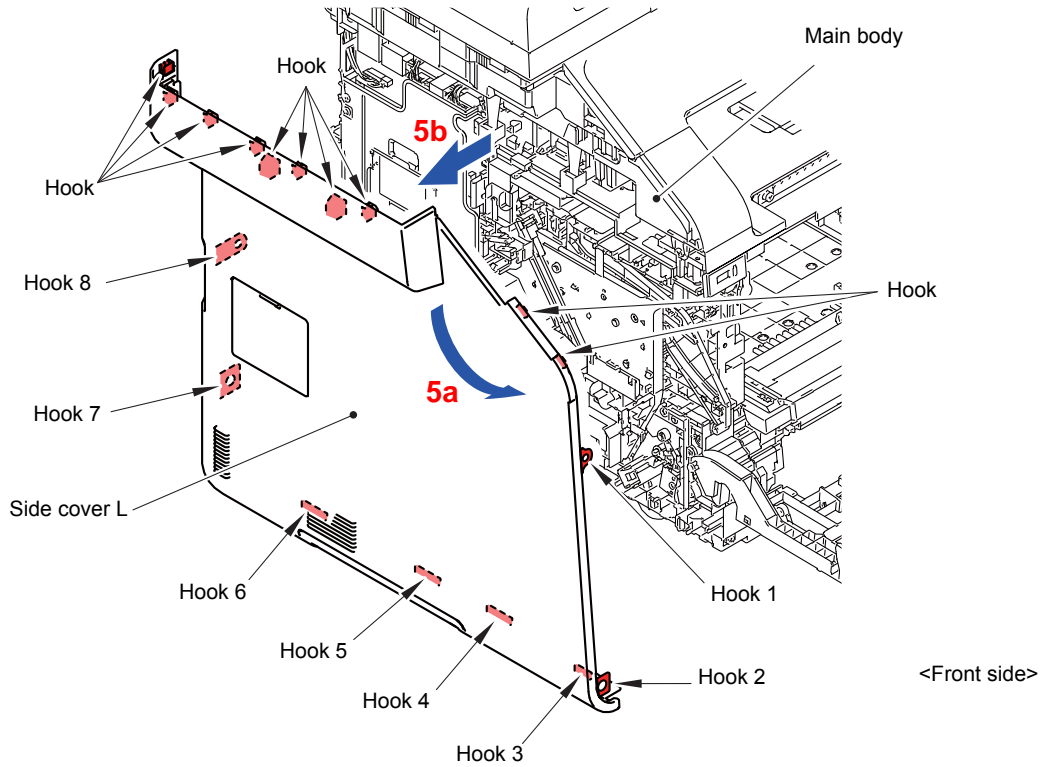

Fig. 3-26

* Inside of Side cover L

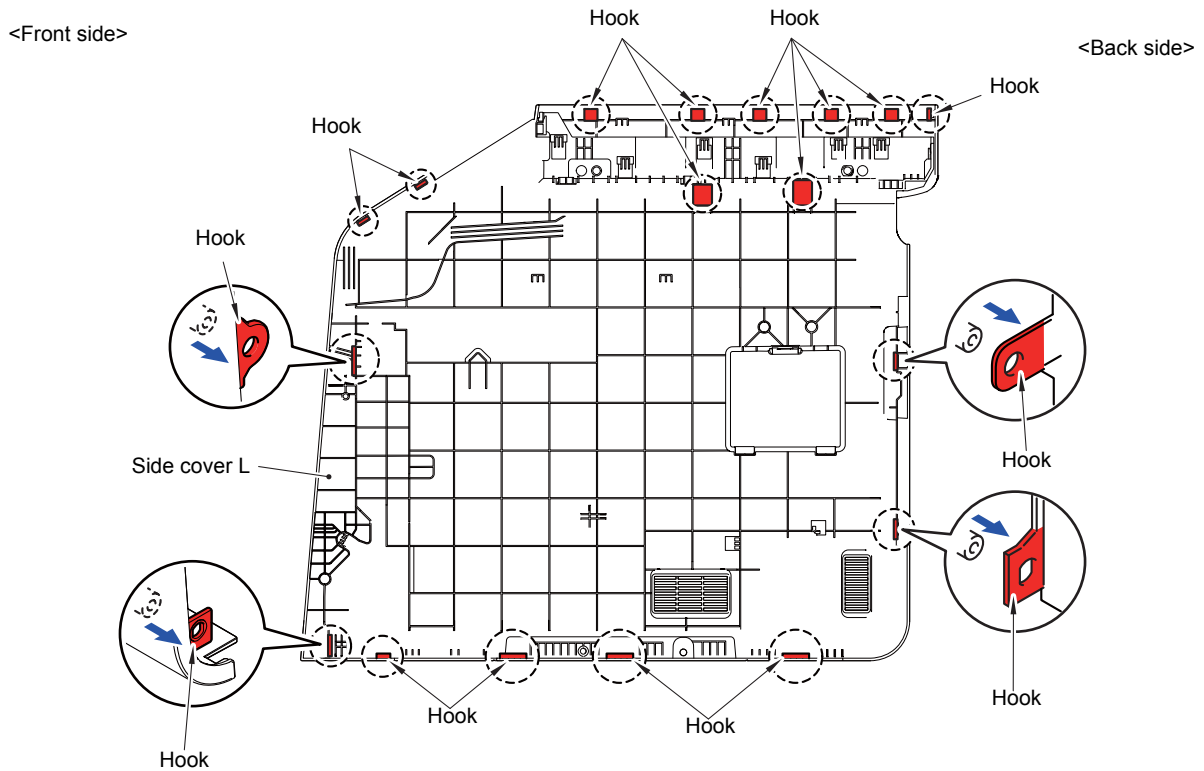

Fig. 3-27

9.8 Side Cover R

- (1) Remove the one Taptite B 3x6 screw and the one Taptite bind B M4x12 screw from the front of the Side cover R.

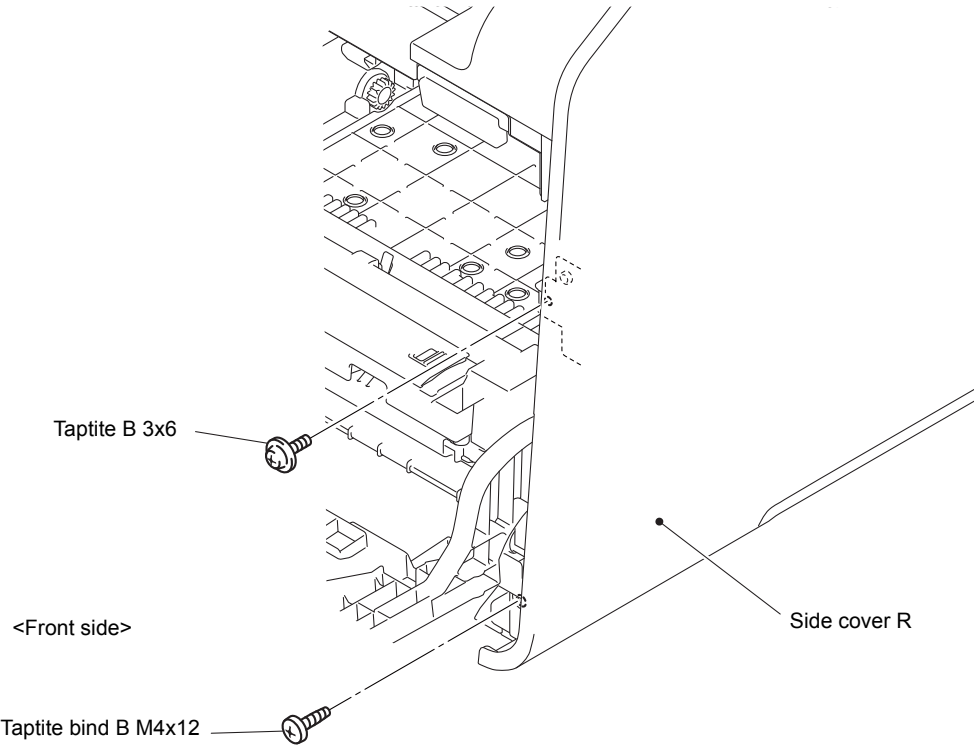

Fig. 3-28

- (2) Remove the two Taptite bind B M4x12 screws from the back of the Side cover R.

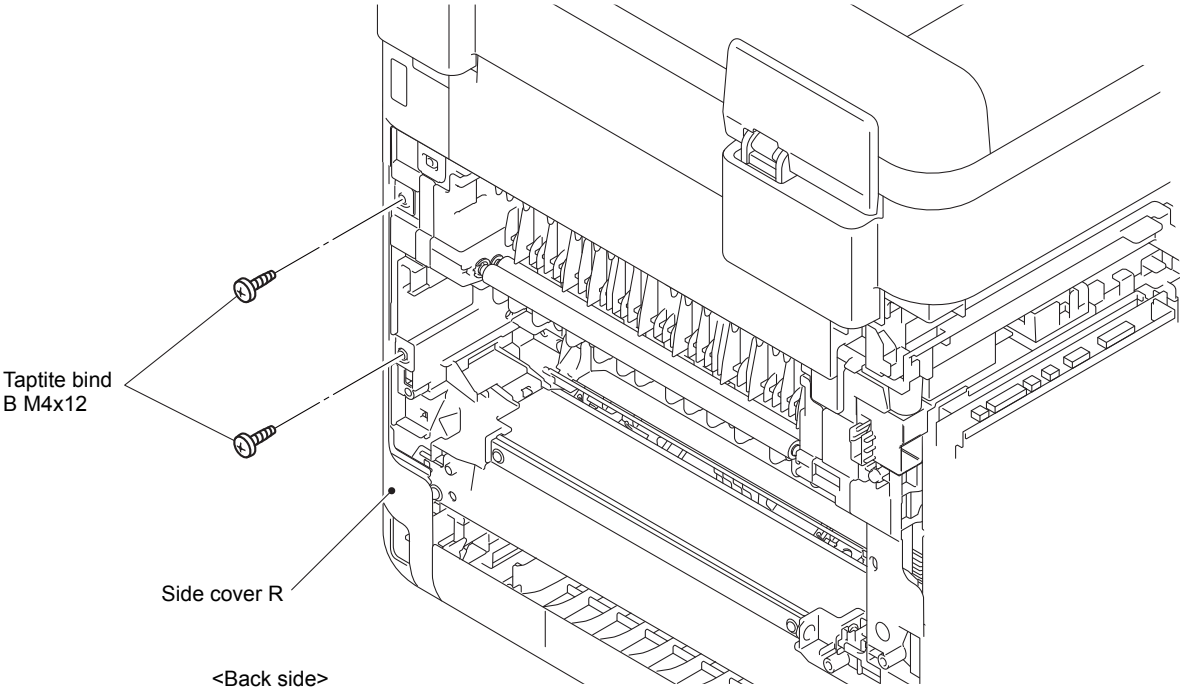

Fig. 3-29

■ A4 model

- (3) Release the Hooks 1 to 7 in numerical order. Move the Side cover R in the direction of the arrow 3a and release the other Hooks and remove Side cover R from the Main body.

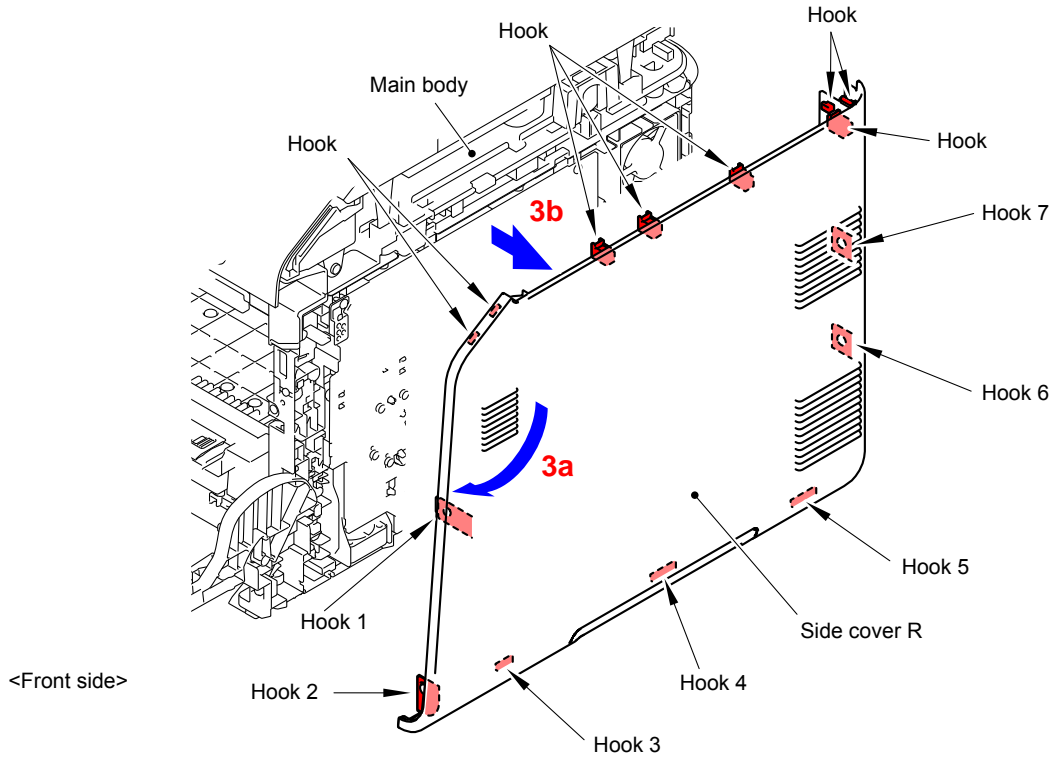

Fig. 3-30

* Inside of Side cover R

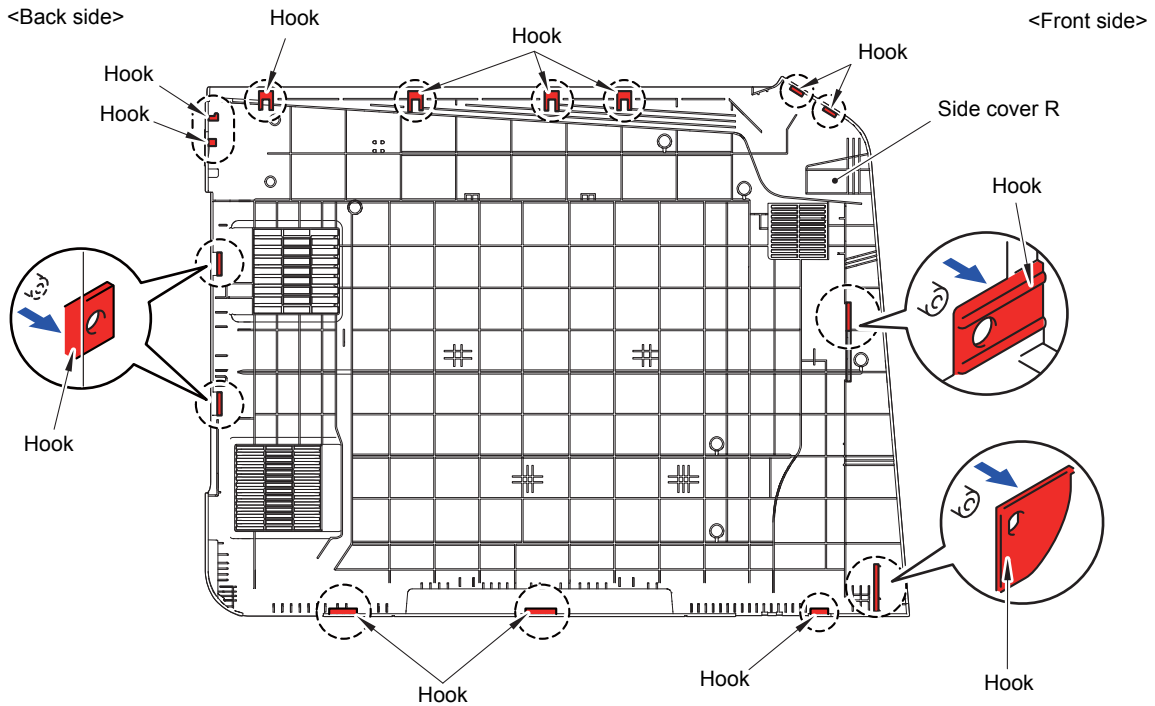

Fig. 3-31

■ Legal model

- (3) Release the Hooks 1 to 7 in numerical order. Move the Side cover R in the direction of the arrow 3a and release the other Hooks and remove Side cover R from the Main body.

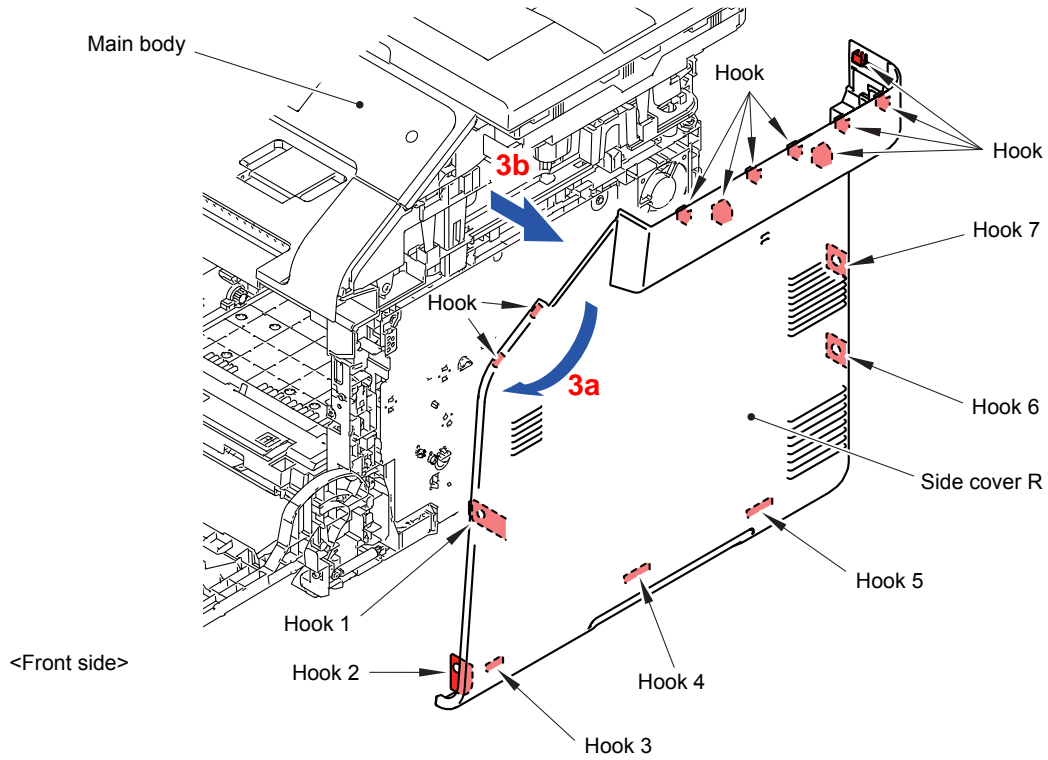

Fig. 3-32

* Inside of Side cover R

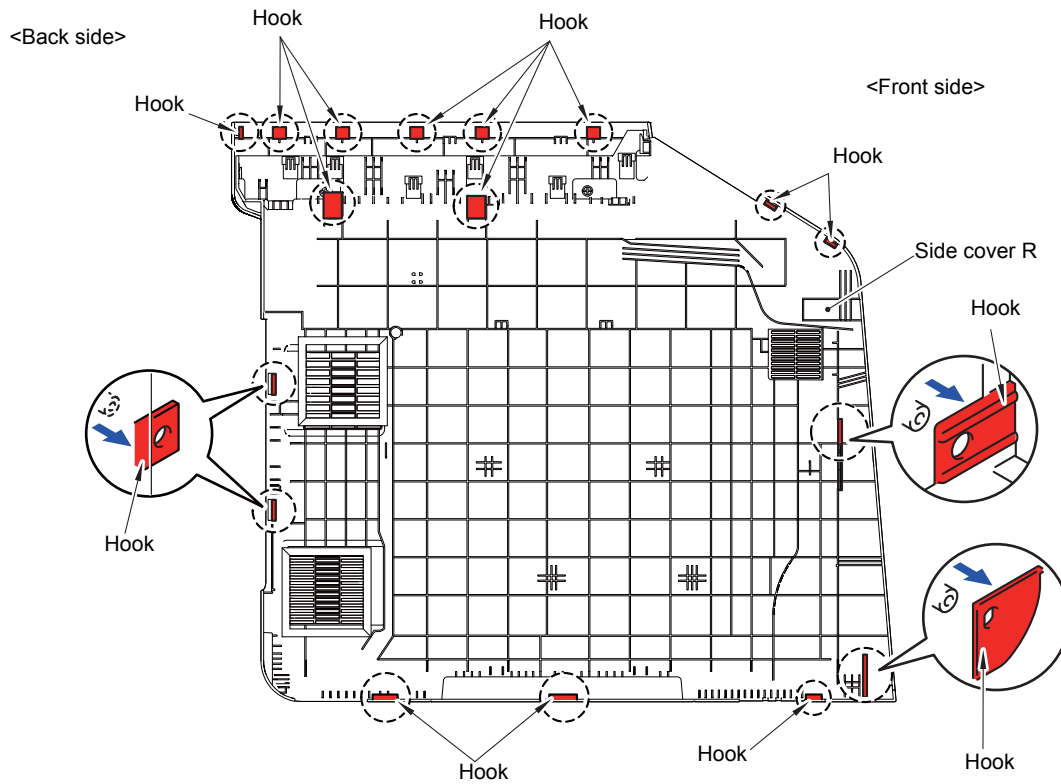

Fig. 3-33

Note:
As the Spacer tends to come off, be careful not to lose it.

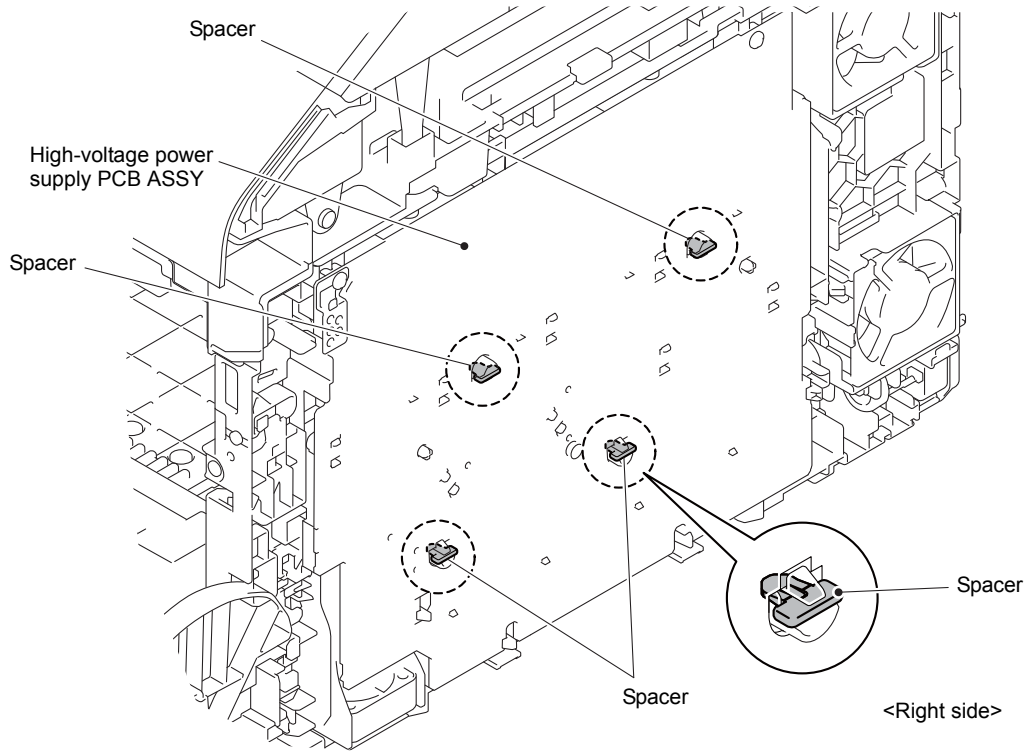

Fig. 3-34

9.9 Duplex Tray

- (1) Remove the two Taptite cup B M3x12 screws and remove the Duplex tray from the Main body.

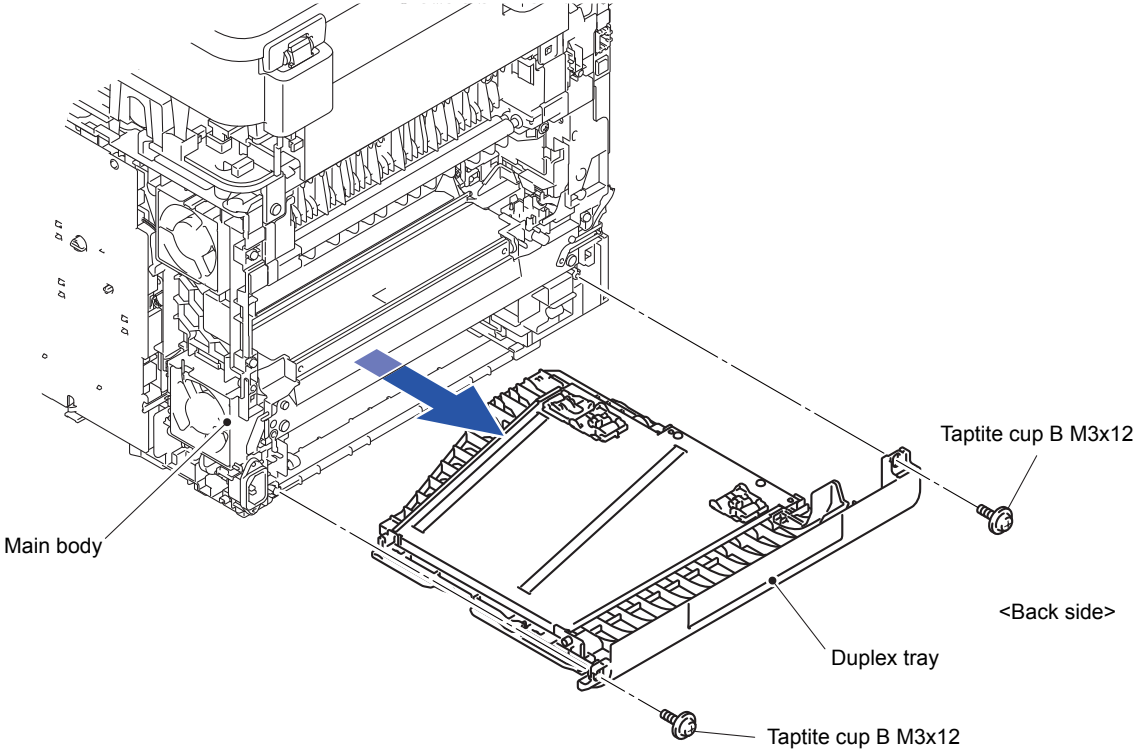

Fig. 3-35

9.10 MP Cover ASSY/MP Paper Guide ASSY

- (1) Close the Front cover.
- (2) Open the MP cover ASSY.

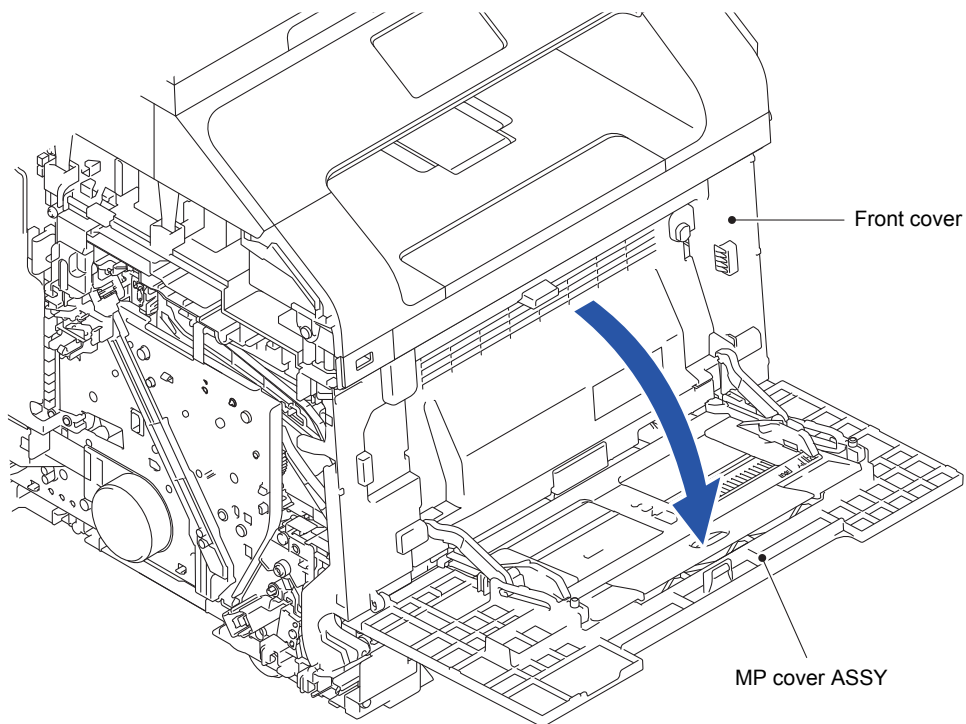

Fig. 3-36

- (3) Release the Pin of the MP link L from the MP cover ASSY.
- (4) Release the Pin of the MP link R from the MP cover ASSY.

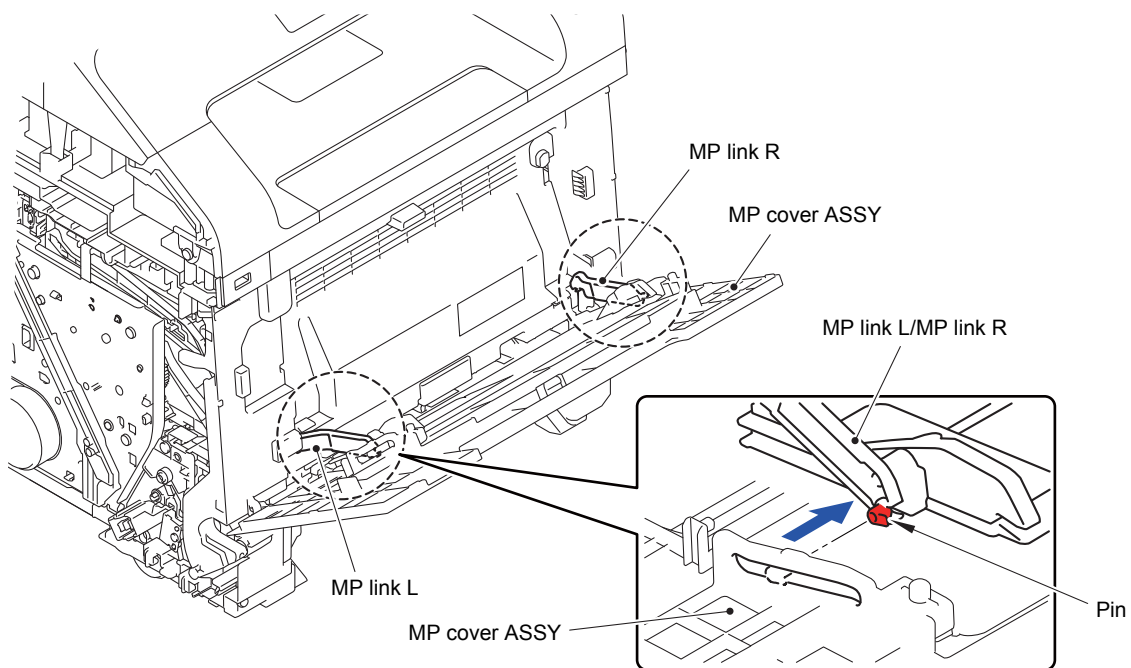

Fig. 3-37

- (5) Release the Pin of the MP link L from the MP paper guide ASSY.
- (6) Release the Pin of the MP link R from the MP paper guide ASSY.

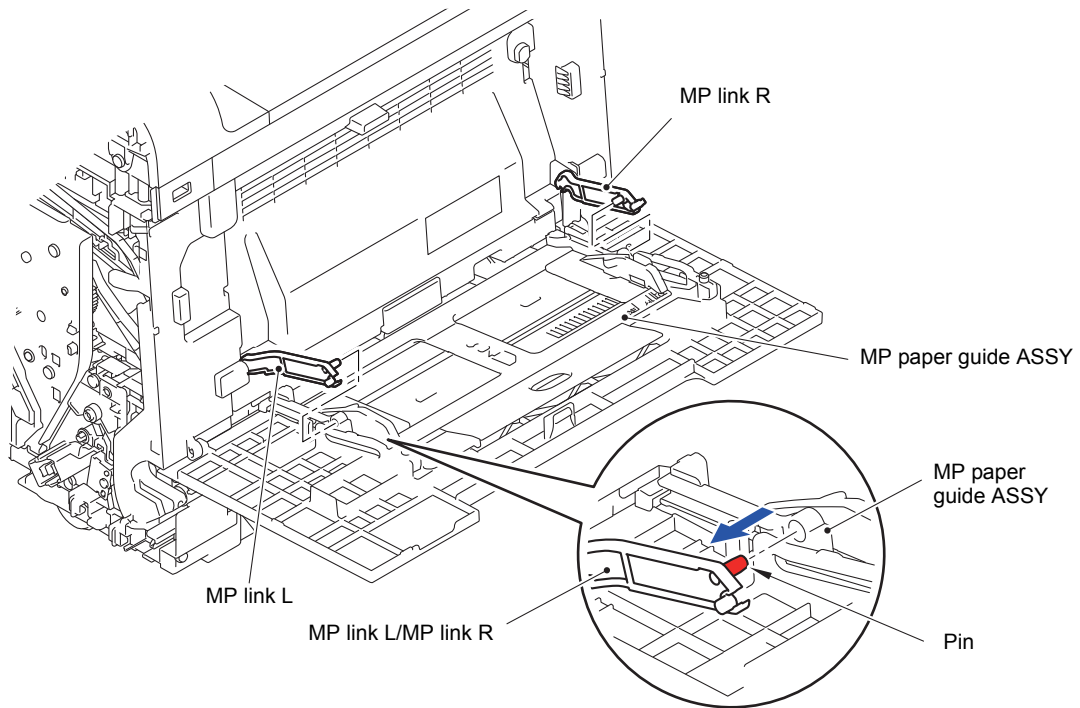

Fig. 3-38

- (7) Slide the MP paper guide ASSY in the direction of the arrow 7b and remove it from MP cover ASSY.

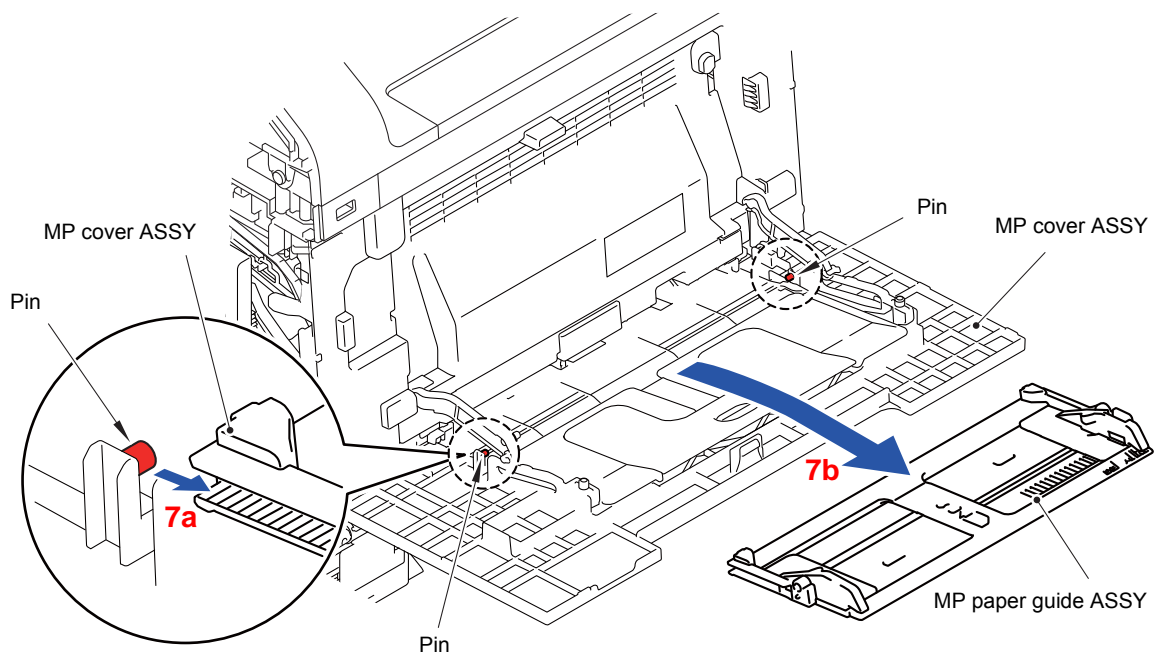

Fig. 3-39

(8) Release the two Pins and remove the MP cover ASSY from the Front cover.

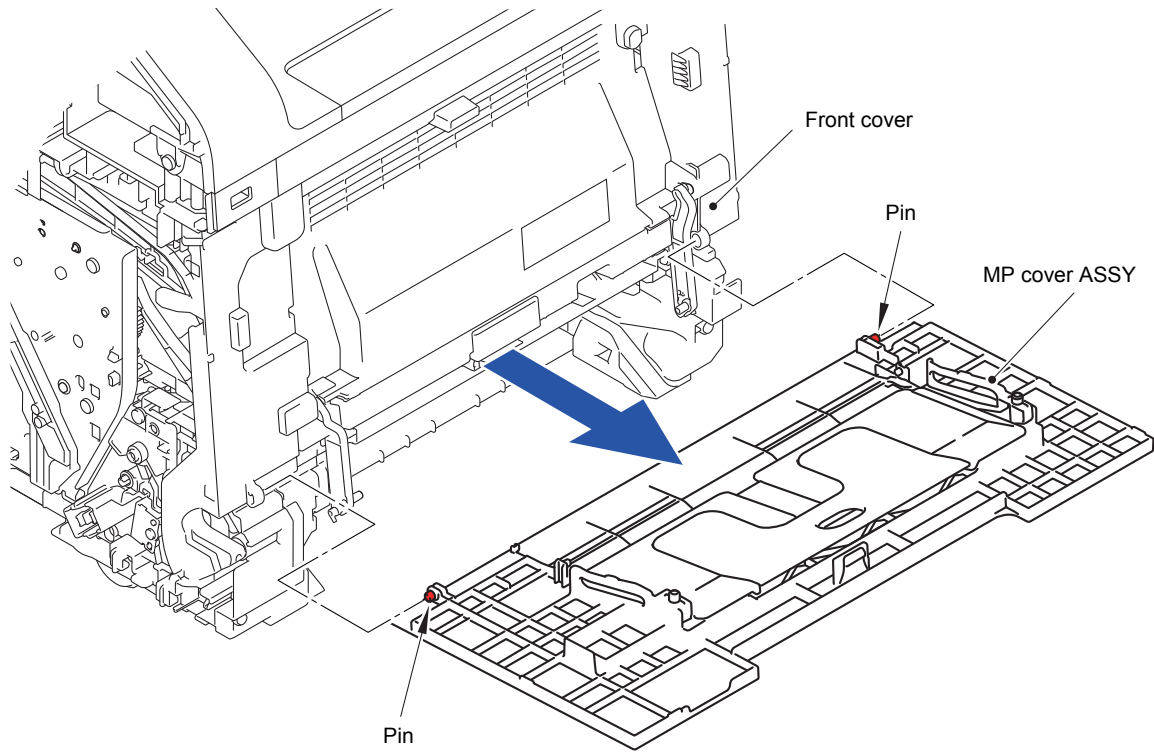

Fig. 3-40

9.11 MP Link L/MP Link R

- (1) Remove the MP link L from the Front cover.
- (2) Remove the MP link R from the Front cover.

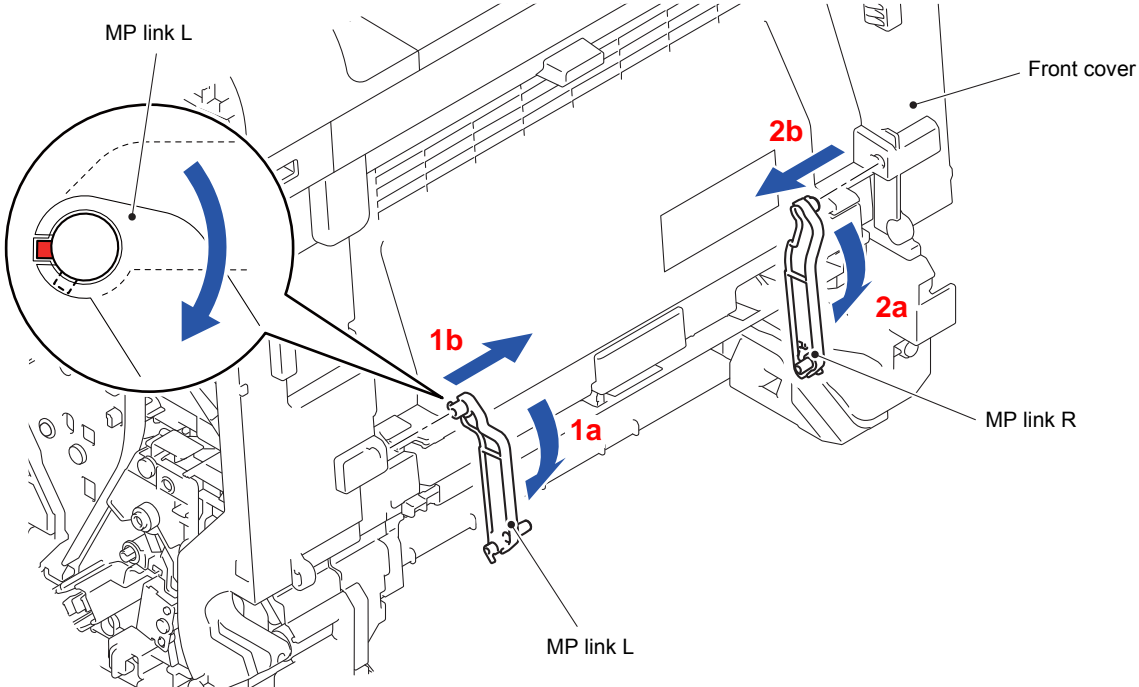

Fig. 3-41

9.12 Front Cover

- (1) Remove the Front cover damper spring from the Spring hook of the Main frame R ASSY.
- (2) Remove the Taptite B 3x6 screw and remove the Front cover damper spring from the Front cover.

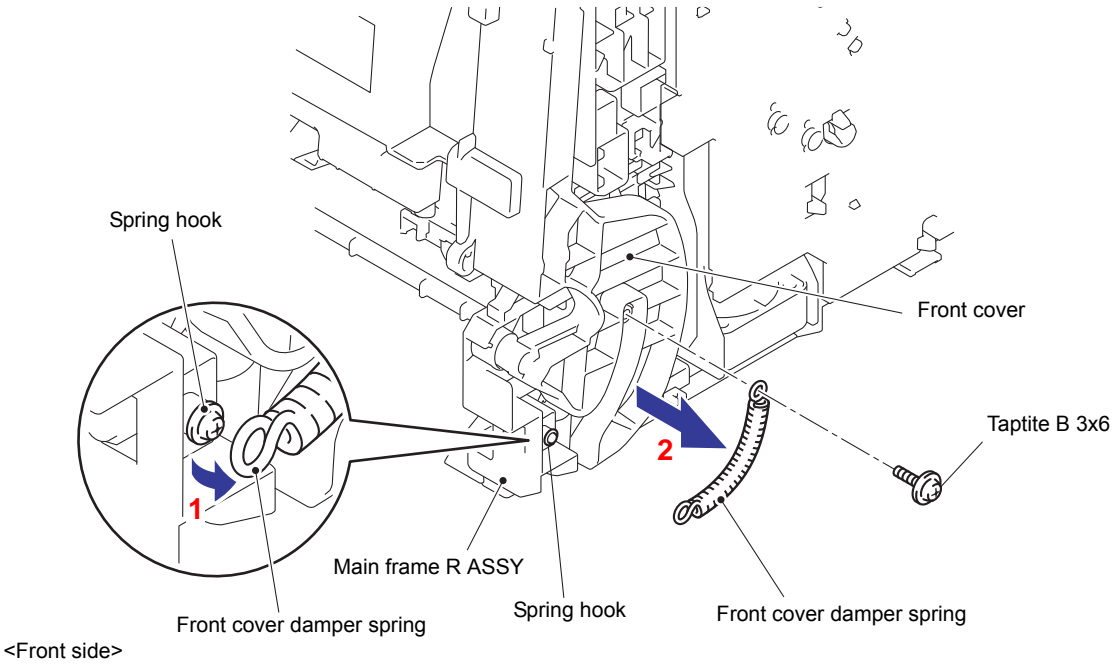

Fig. 3-42

- (3) Open the Front cover.
- (4) Release the Hook and remove the Forced develop release link from the Front cover.

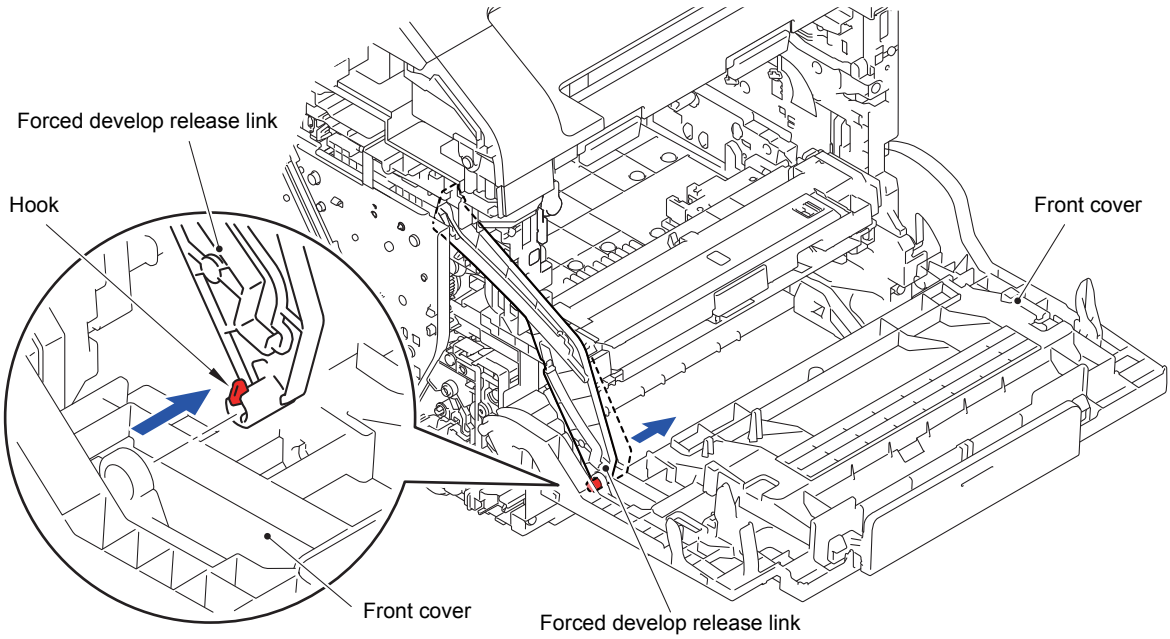

Fig. 3-43

(5) Release the three Bosses and remove the Front cover from the Main body.

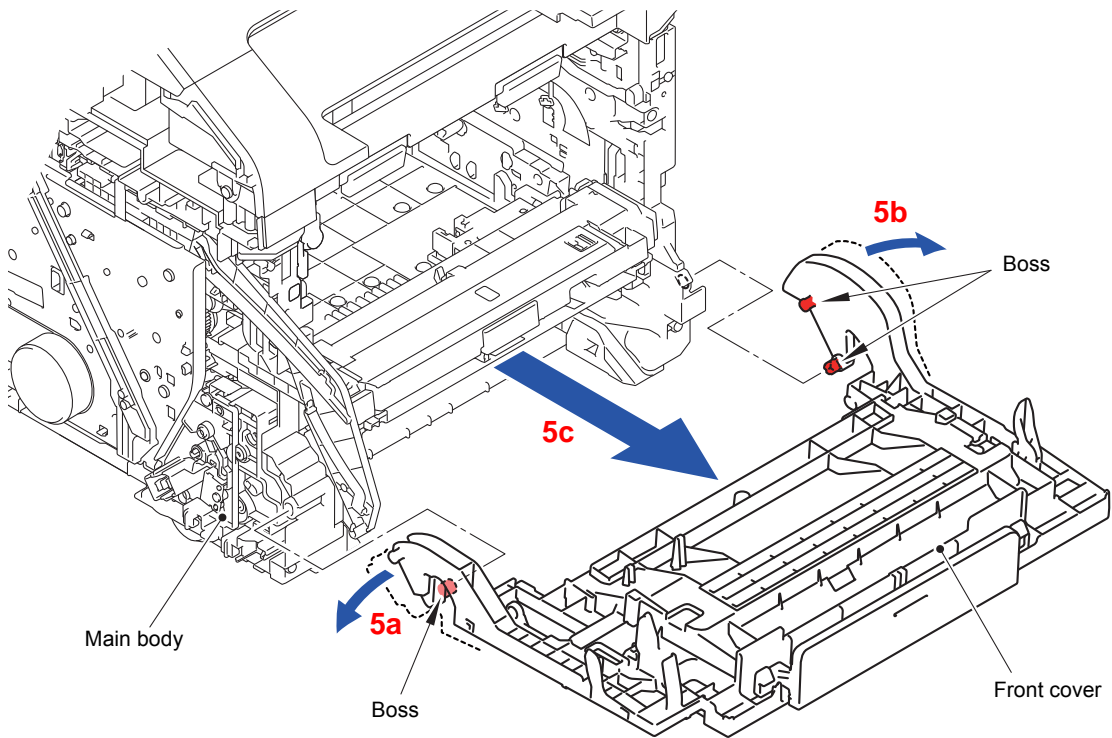

Fig. 3-44

9.13 Front Cover Release Button/ Front Cover Release Button Spring

- (1) Release the Hook, tilt the Front cover release button in the direction of the arrow 1b, and remove it from the Boss.

Assembling Note:

Align the Hole of the Front cover release button to the Boss of the Front cover and insert it into the Hole.

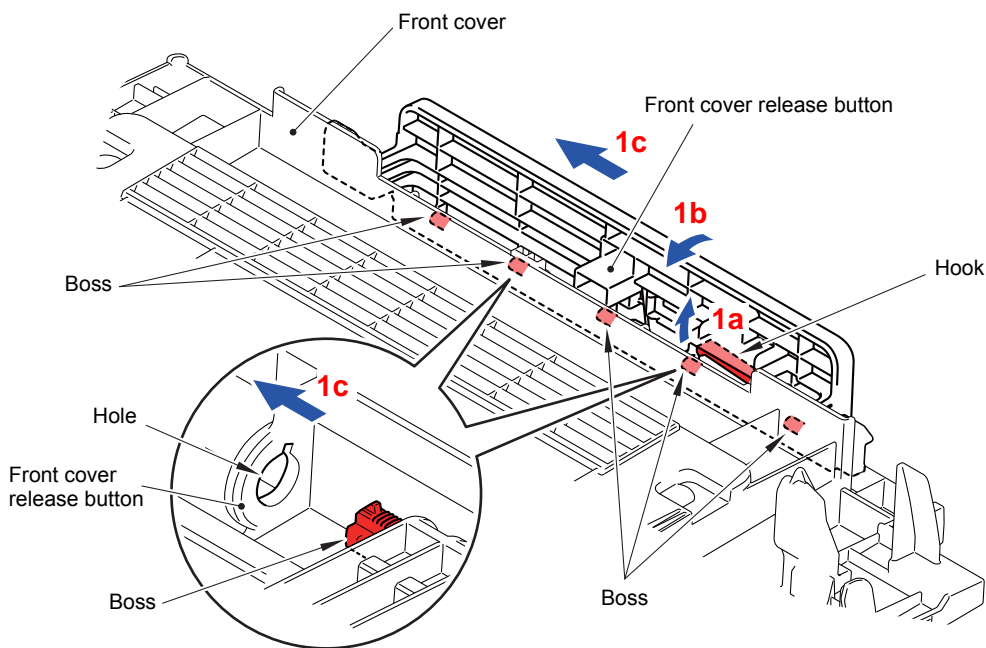

Fig. 3-45

- (2) Tilt the Front cover release button in the direction of the arrow 2a, and remove it from the Front cover.

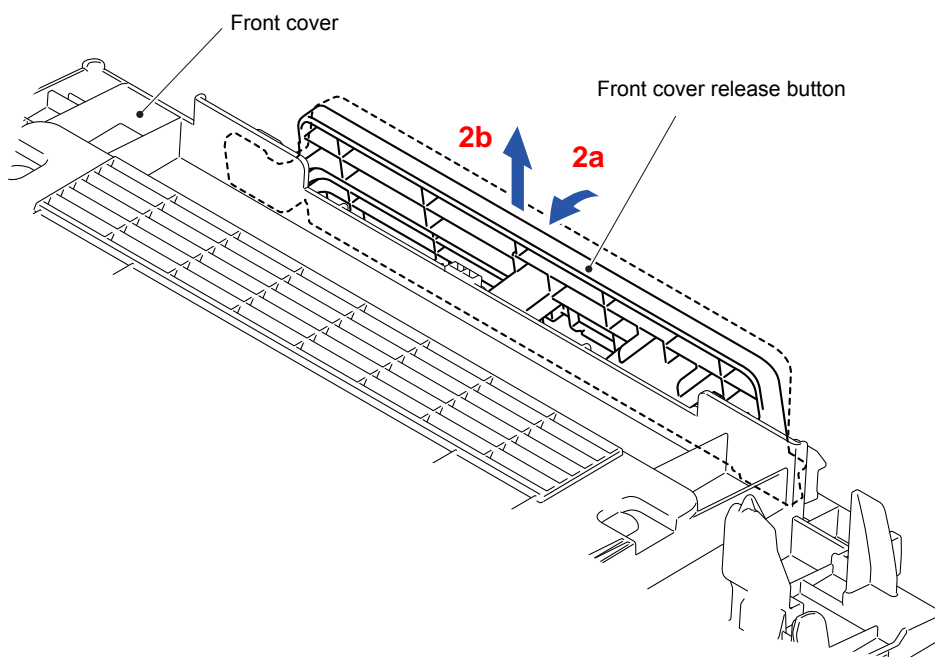

Fig. 3-46

(3) Remove the Front cover release button spring from the Front cover.

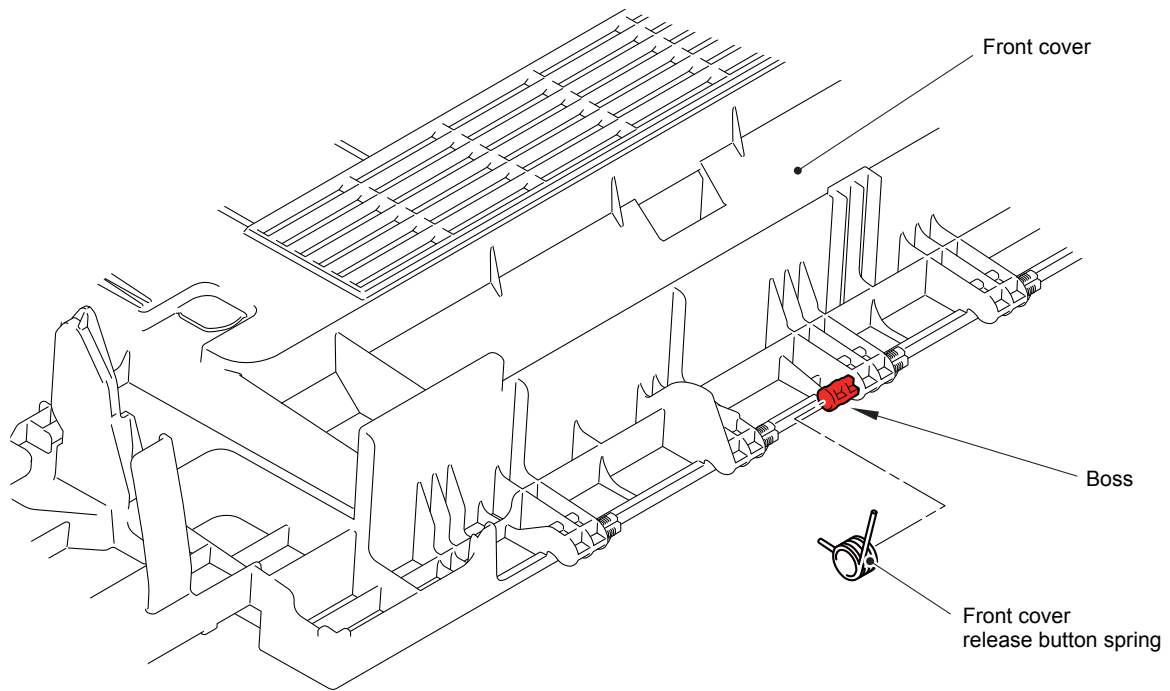

Fig. 3-47

Assembling Note:

When assembling the Front cover release button spring, attach "A" of the Front cover release button spring to the cutout of the Front cover release button.

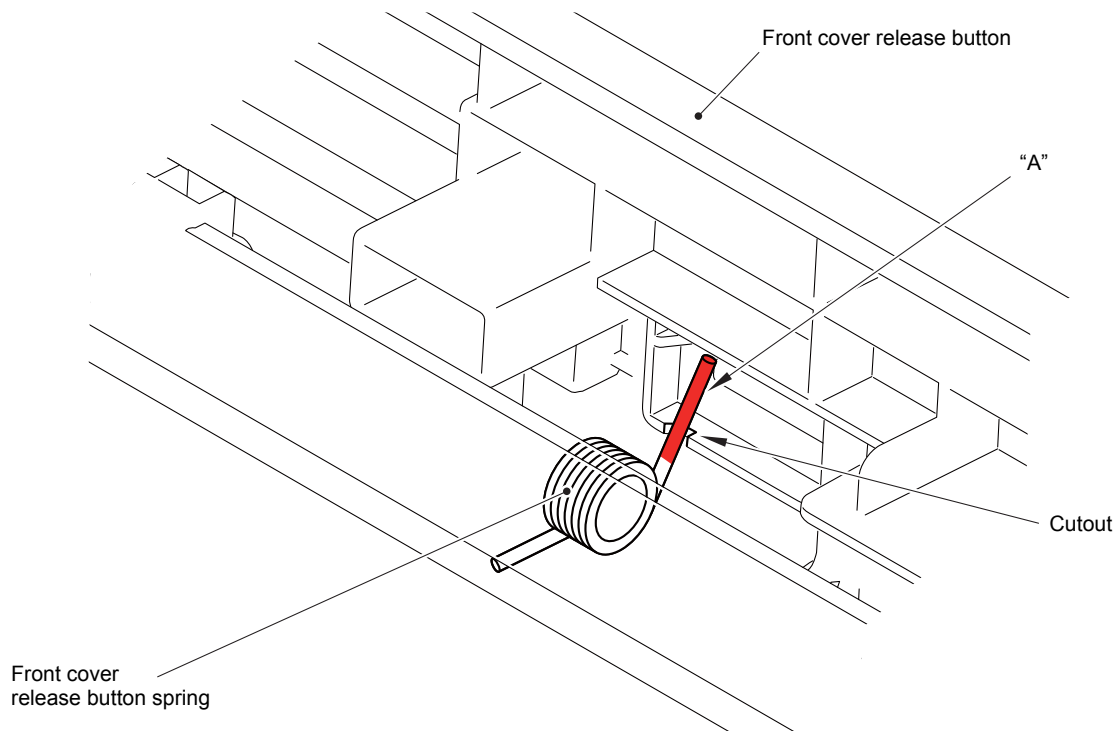

Fig. 3-48

9.14 Support Flap

Memo:

Follow the procedure (2) only in the case of the Legal model.

- (1) Open the Document scanner unit.

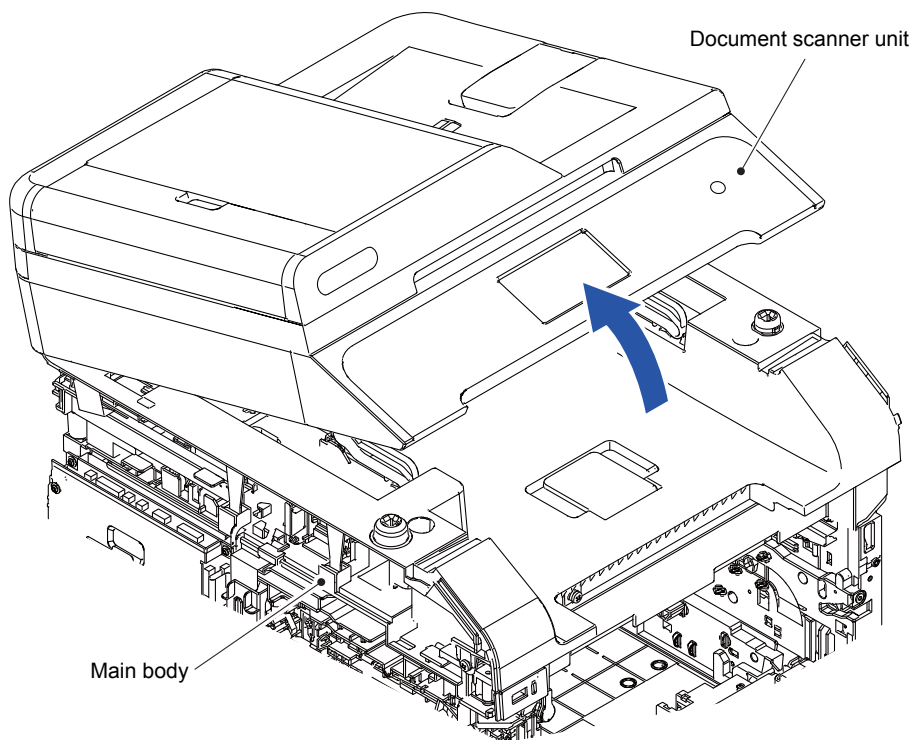

Fig. 3-49

- (2) Release the two Pins and remove the Support flap from the Main body.

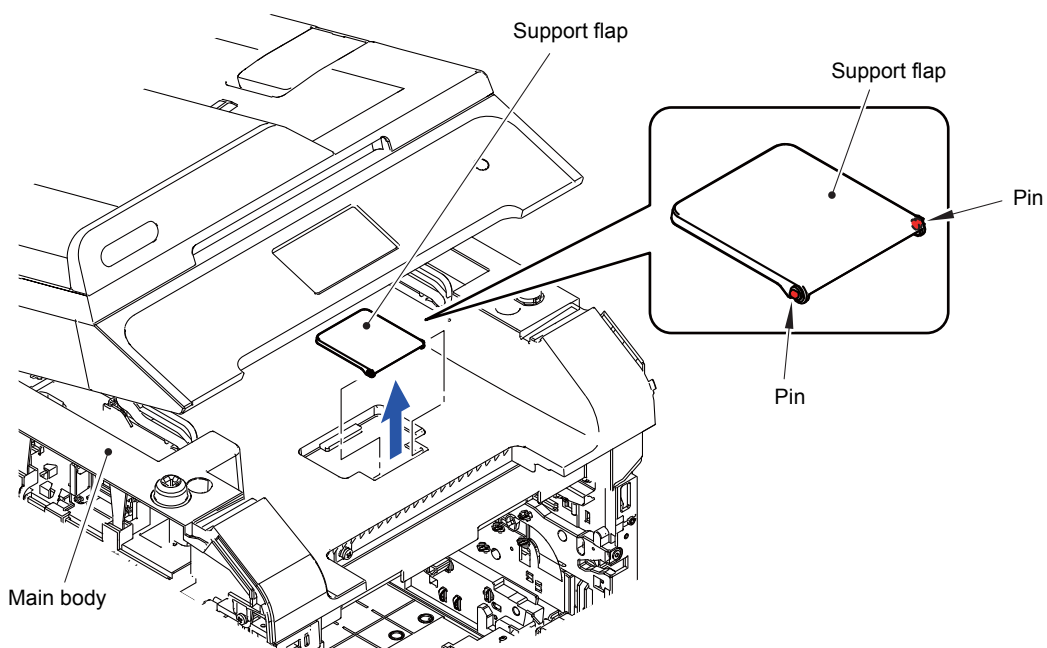

Fig. 3-50

9.15 Pull Arm L/Pull Arm R (A4 Model Only)

- (1) Open the Pull arm L and Pull arm R and release the Hooks from the joint of the Document scanner unit.

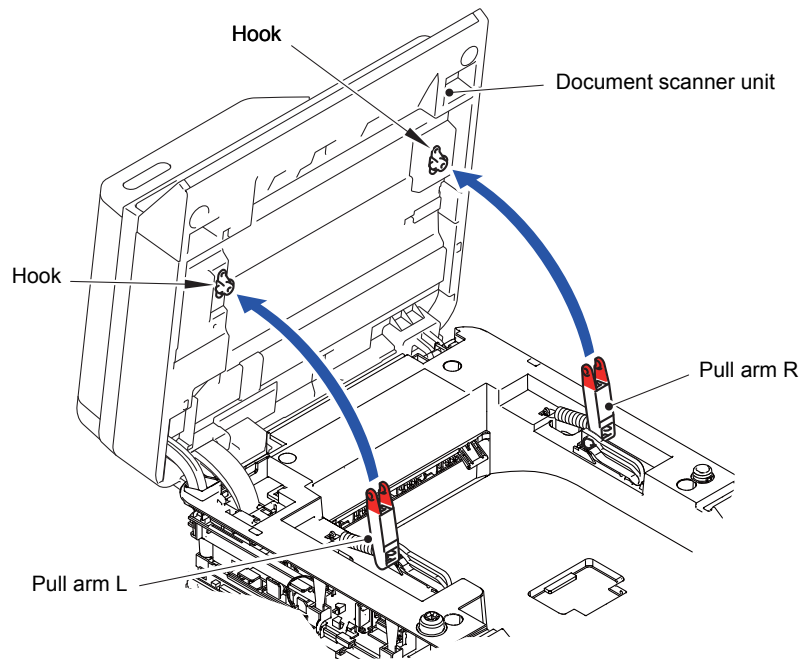

Fig. 3-51

- (2) Remove the Pull arm L and Pull arm spring from the Pull arm guide.
- (3) Remove the Pull arm R and Pull arm spring from the Pull arm guide.

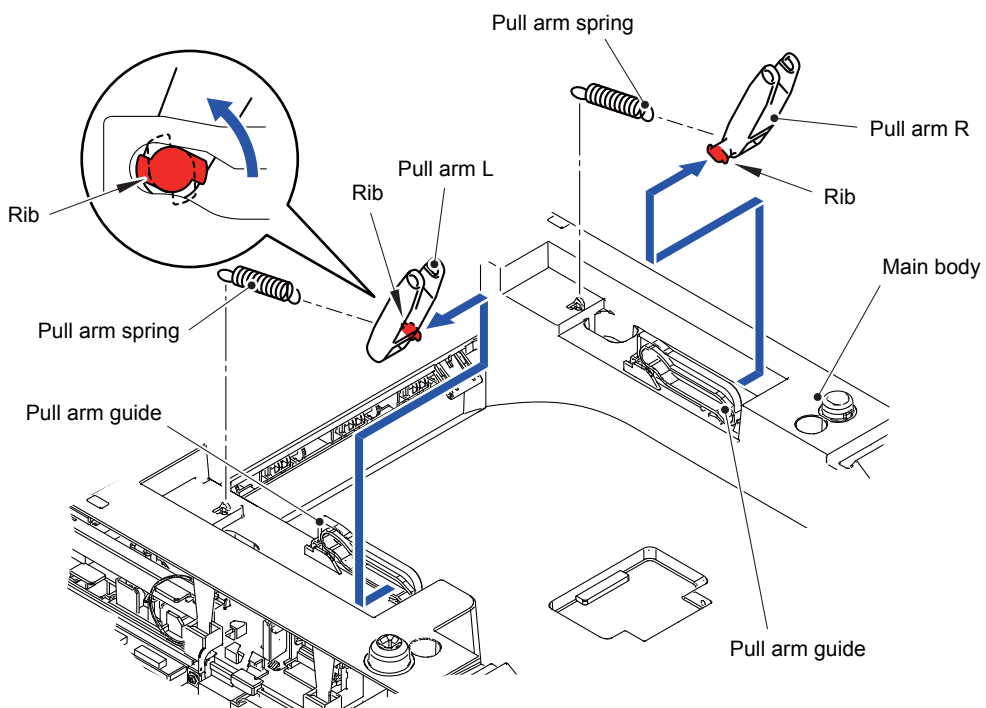

Fig. 3-52

9.16 Back Cover Upper (Legal Model Only)

- (1) Remove the two Taptite bind B M4x12 screws from the Back cover upper.
- (2) Release the four Hooks and remove the Back cover upper from the Main body.

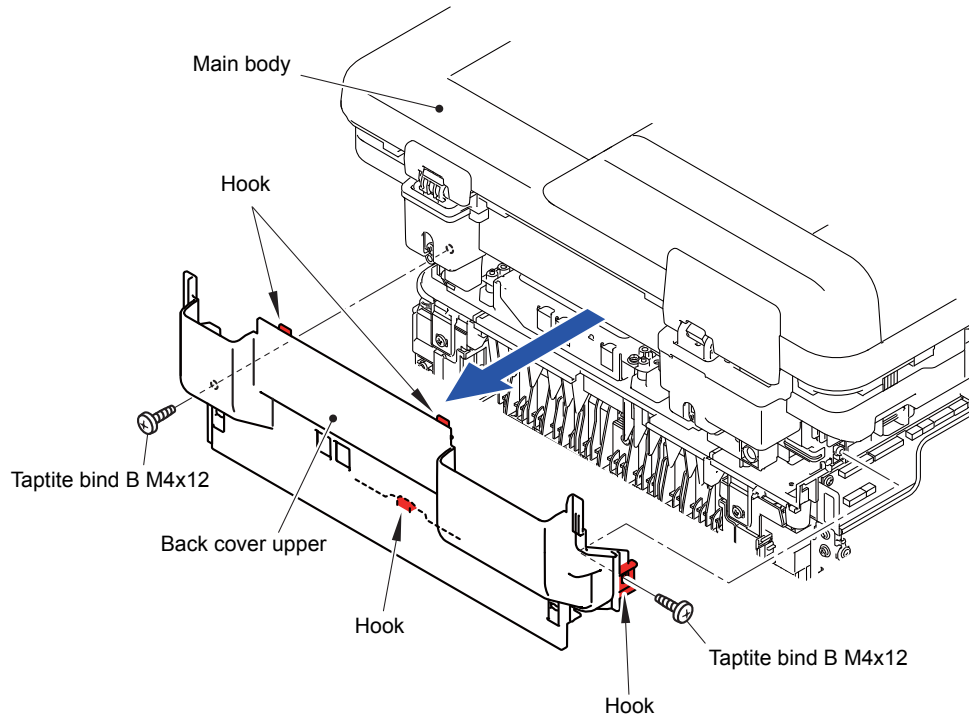

Fig. 3-53

9.17 ADF Unit/Hinge ASSY L/Hinge R/Hinge R Support

■ A4 model

- (1) Remove the Screw bind M3x8 screw and remove the Panel FG harness from the Main shield cover plate ASSY.
- (2) Remove the three Screw bind M3x8 screws and remove the Main shield cover plate ASSY from the Main body.

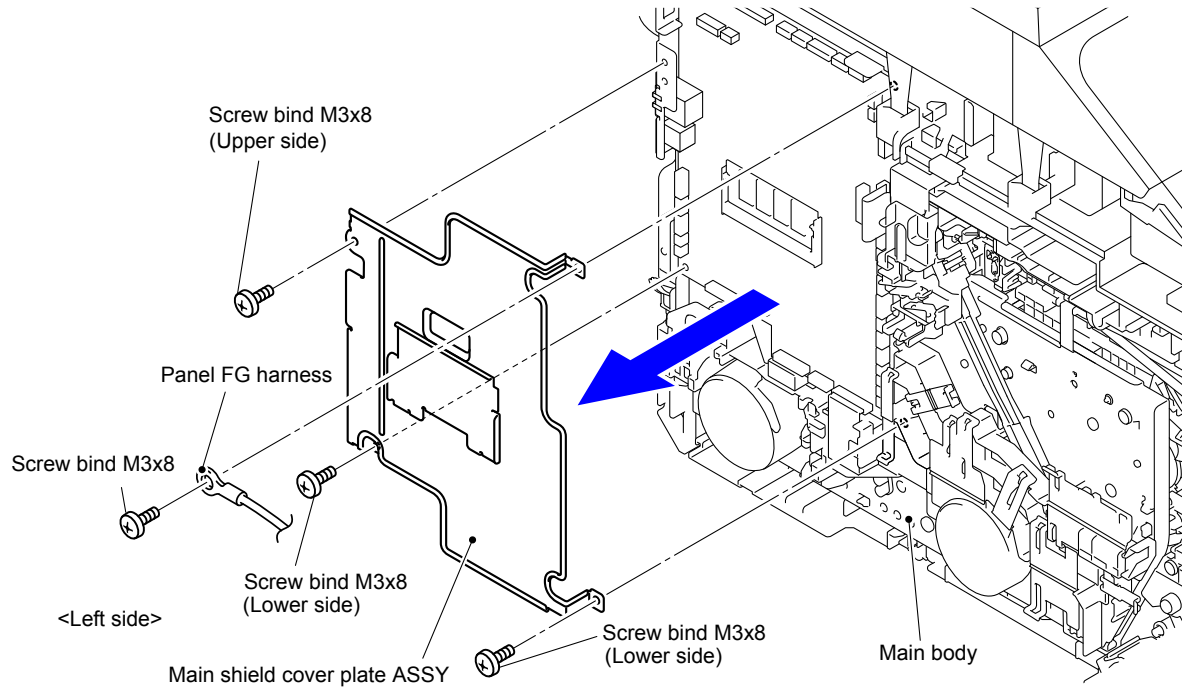

Fig. 3-54

Note:

Note that the tightening torque is different between the upper side and lower side of the Screw bind M3x8.

Upper side: 0.5 ± 0.05 N·m

Lower side: 0.8 ± 0.1 N·m

- (3) Remove the two Screw bind M3x8 screws and remove the ADF earth harness and Document scanner FG harness from the Main PCB plate.
- (4) Disconnect the two Connectors (CN39 and CN41) from the Main PCB ASSY and release the wiring of the Main PCB insulation sheet.

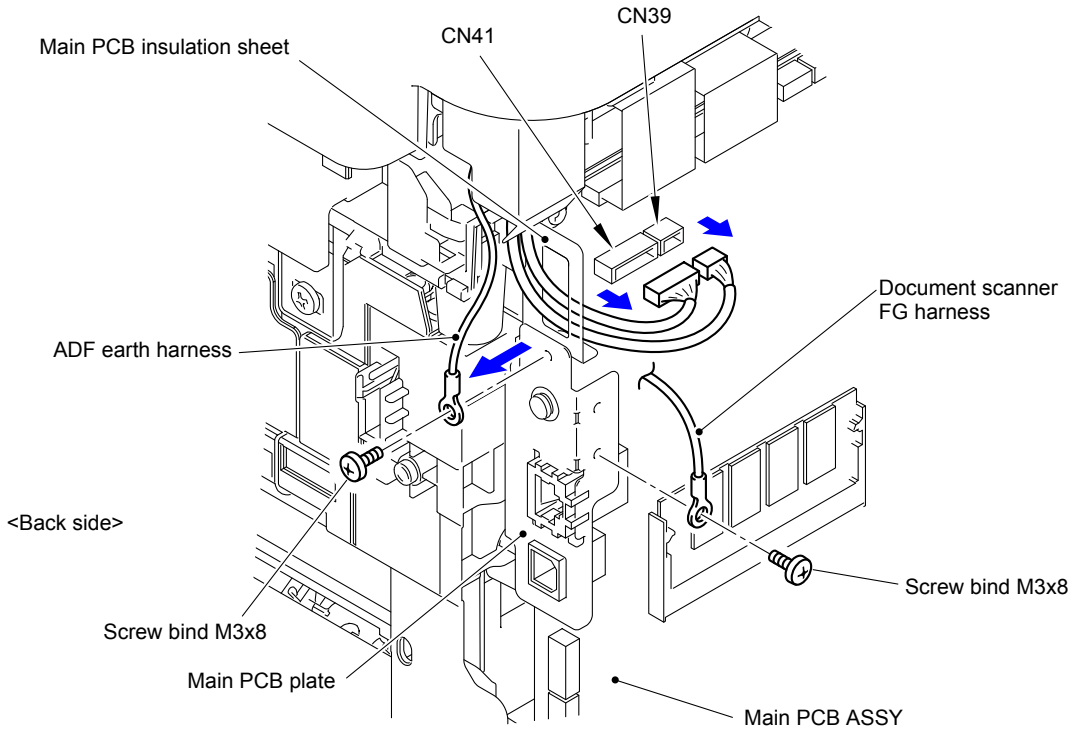

Fig. 3-55

- (5) Disconnect the four Connectors (CN20, CN27, CN32 and CN33) and two Flat cables (CN37 and CN38) from the Main PCB ASSY.

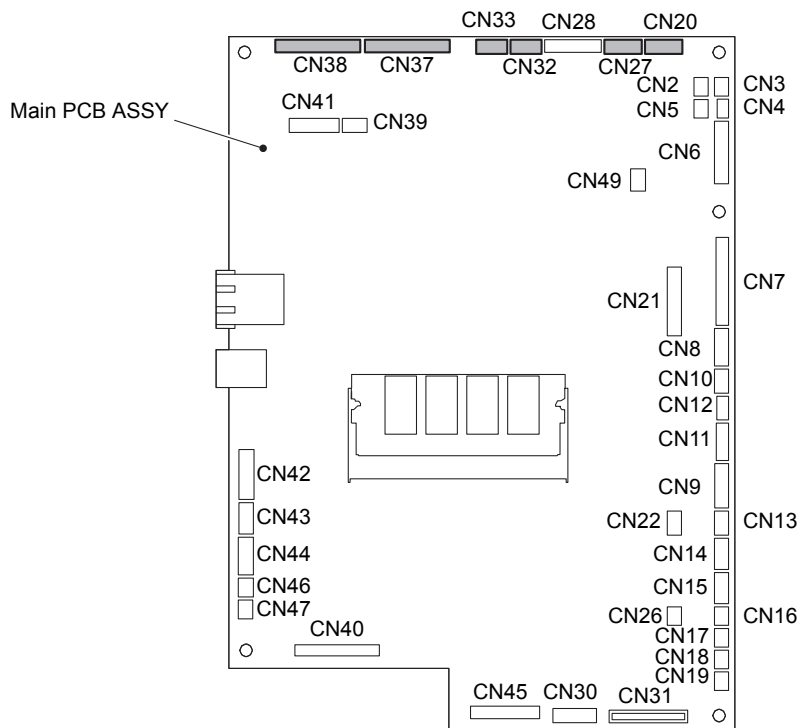

Fig. 3-56

- (6) Open the Document scanner unit and pull out the First side CIS flat cable and Second side CIS flat cable from the Flat core.

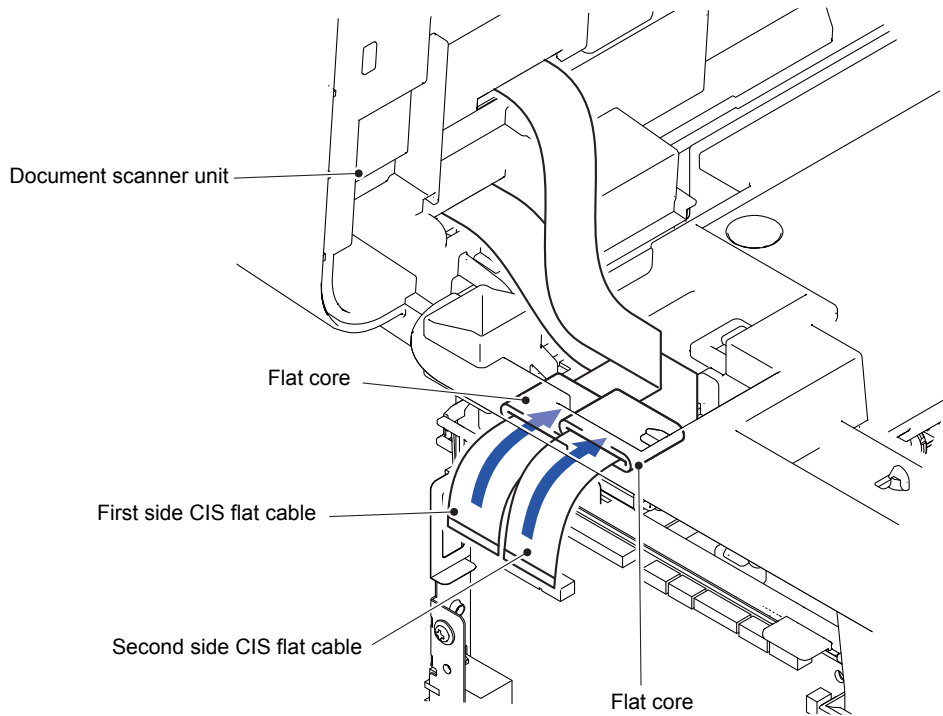

Fig. 3-57

- (7) Release all the wiring passes through the Hole of the Joint cover top.
(8) Change the angle of the Document scanner unit as shown in the figure to remove it from the Main body.

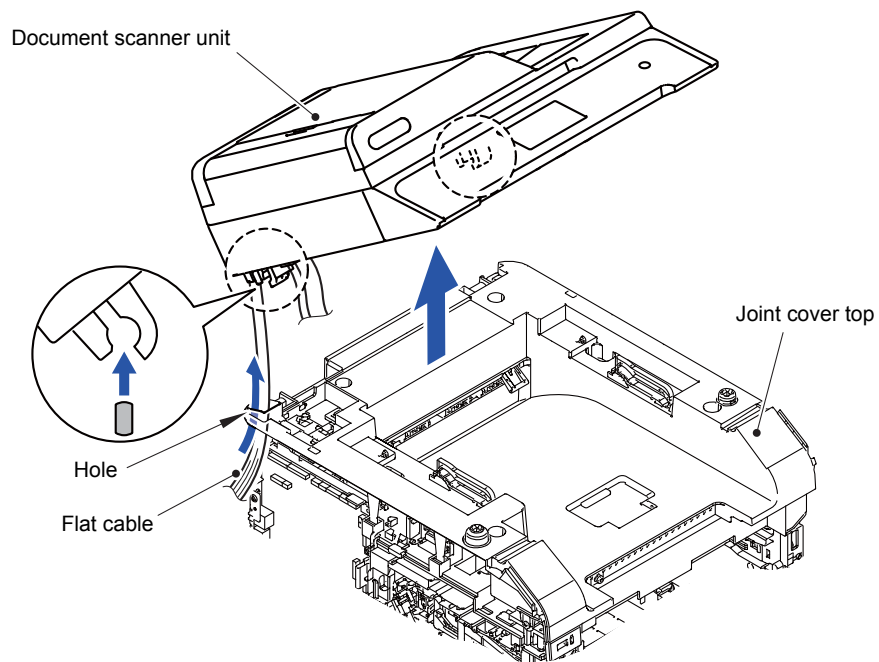

Fig. 3-58

(9) Remove the two Taptite bind B M4x12 screws from the ADF unit.

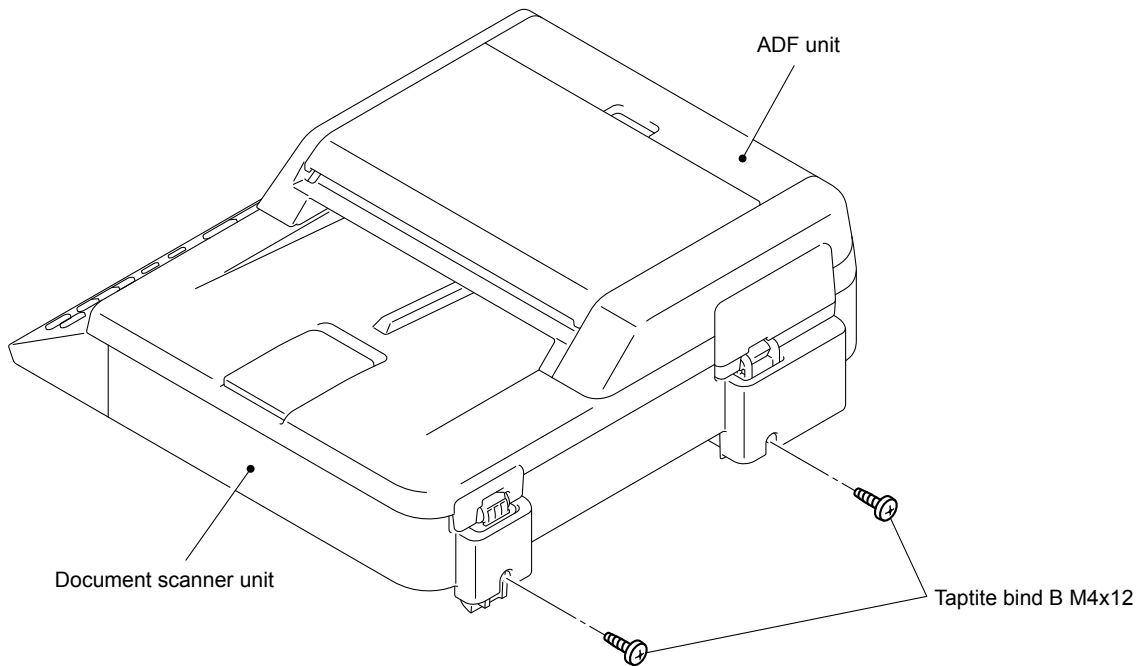

Fig. 3-59

(10) Open the ADF unit.

(11) Release the three Hooks and remove the Flat cable holder from the Document scanner unit.

(12) Pull out the Harness of the ADF unit from the Hole of the Document scanner unit.

(13) Remove the ADF unit from the Document scanner unit.

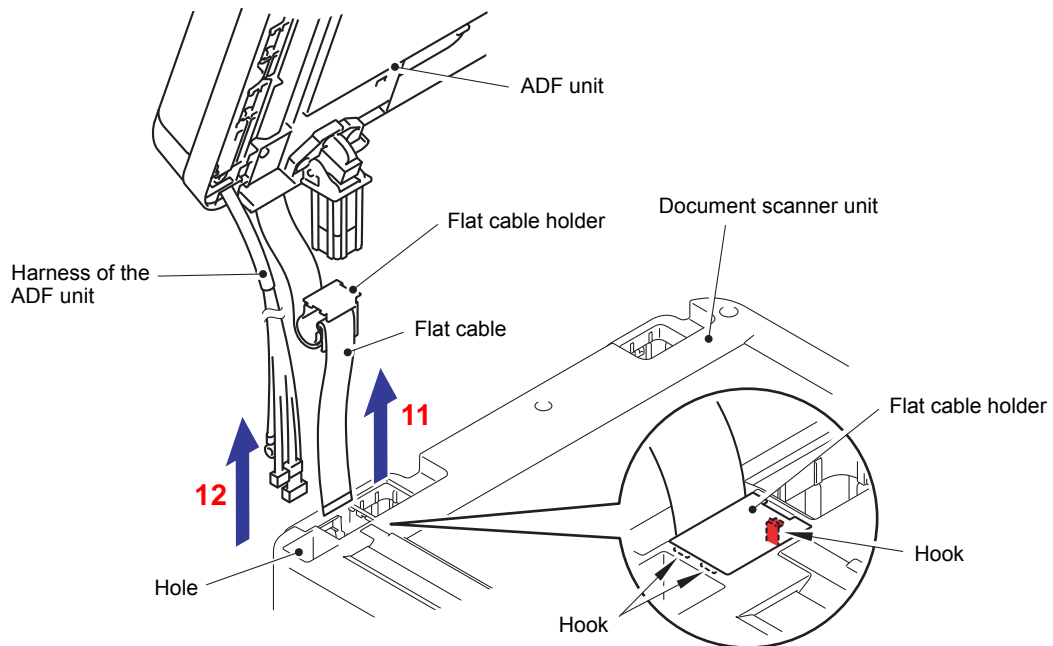

Fig. 3-60

Assembling Note:

- When assembling the Flat cable holder, take care not to accidentally damage the Hooks, which are easily get broken.
- When the ADF unit is replaced, be sure to fold and assemble the Second side CIS flat cable as shown in the figure.
- After disconnecting Flat cables, check that each cable is not damaged at its end or short-circuited.
- When connecting Flat cables, do not insert them at an angle. After insertion, check that the cables are not at an angle.

<How to fold the Second side CIS flat cable>

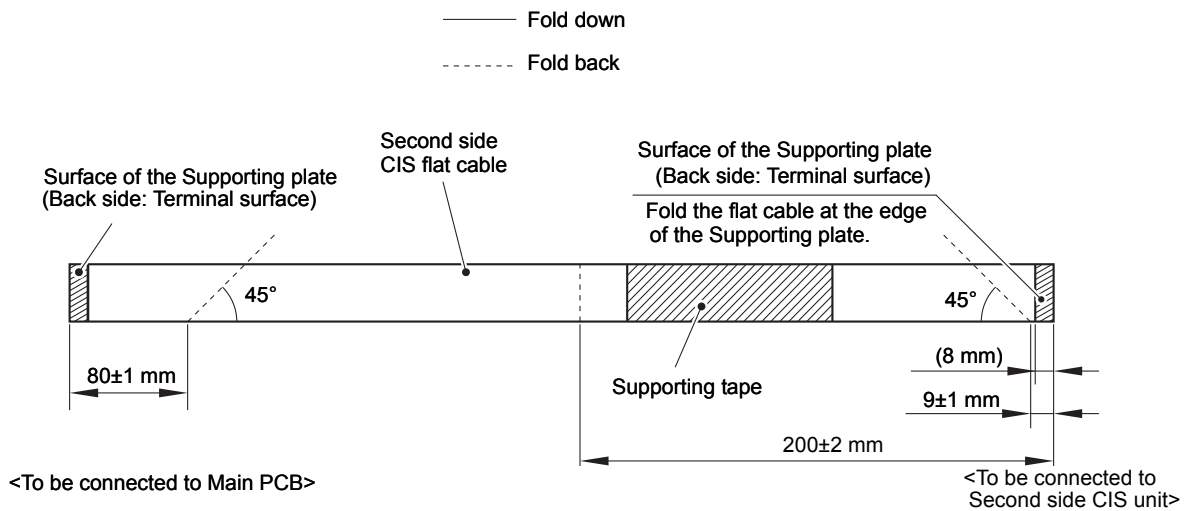

Fig. 3-61

- (14) Turn the ADF unit upside down.
- (15) Remove the three Taptite cup S M3x12 screws and remove the Hinge ASSY L from the ADF unit.

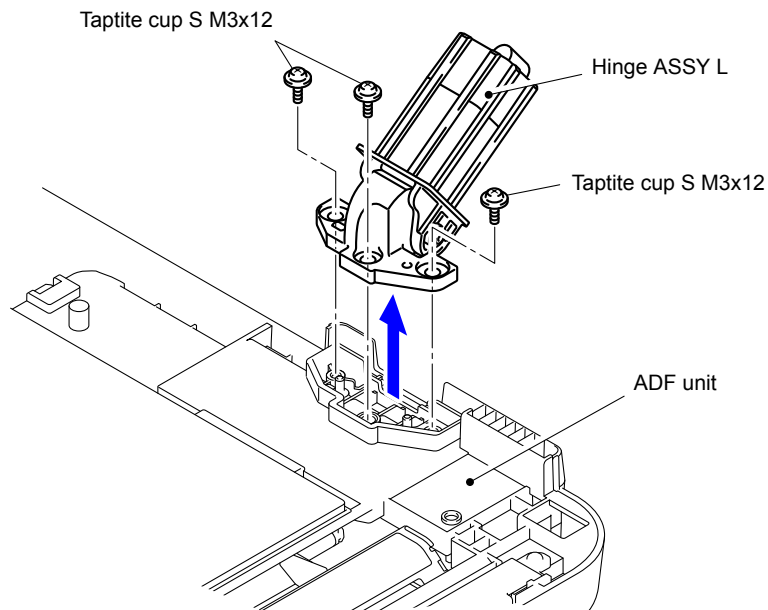

Fig. 3-62

(16) Remove the Taptite cup B M3x10 screw and remove the Hinge R and Hinge R support from the ADF unit.

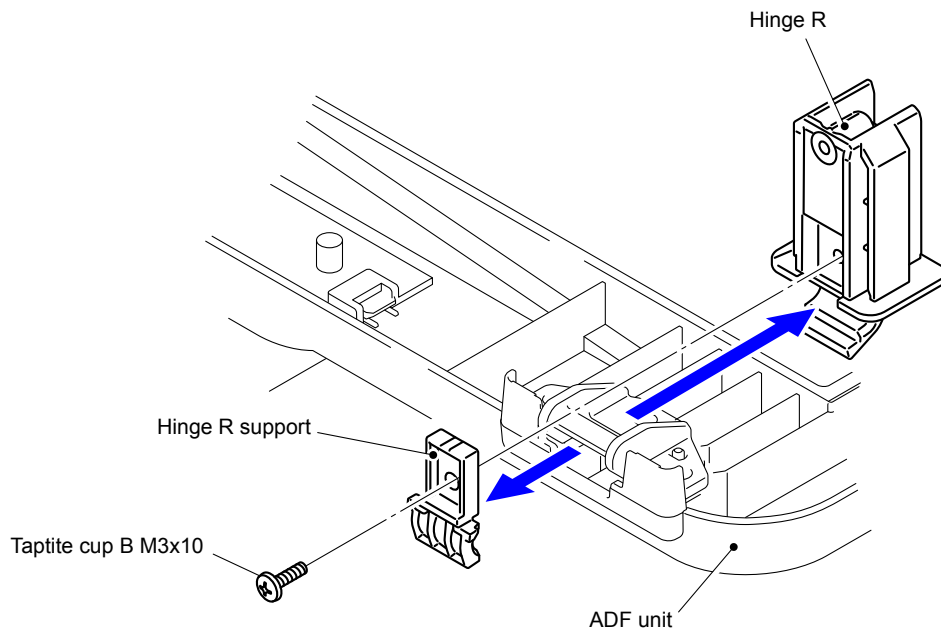

Fig. 3-63

Harness routing: Refer to “[13 ADF \(A4 model\)](#)”, “[15 Document Scanner Unit \(A4 model\)](#)”, “[17 Control Panel ASSY \(A4 model\)](#)”

■ Legal model

- (1) Remove the Screw bind M3x8 screw and remove the Panel FG harness from the Main shield cover plate ASSY.
- (2) Remove the three Screw bind M3x8 screws and remove the Main shield cover plate ASSY from the Main body.

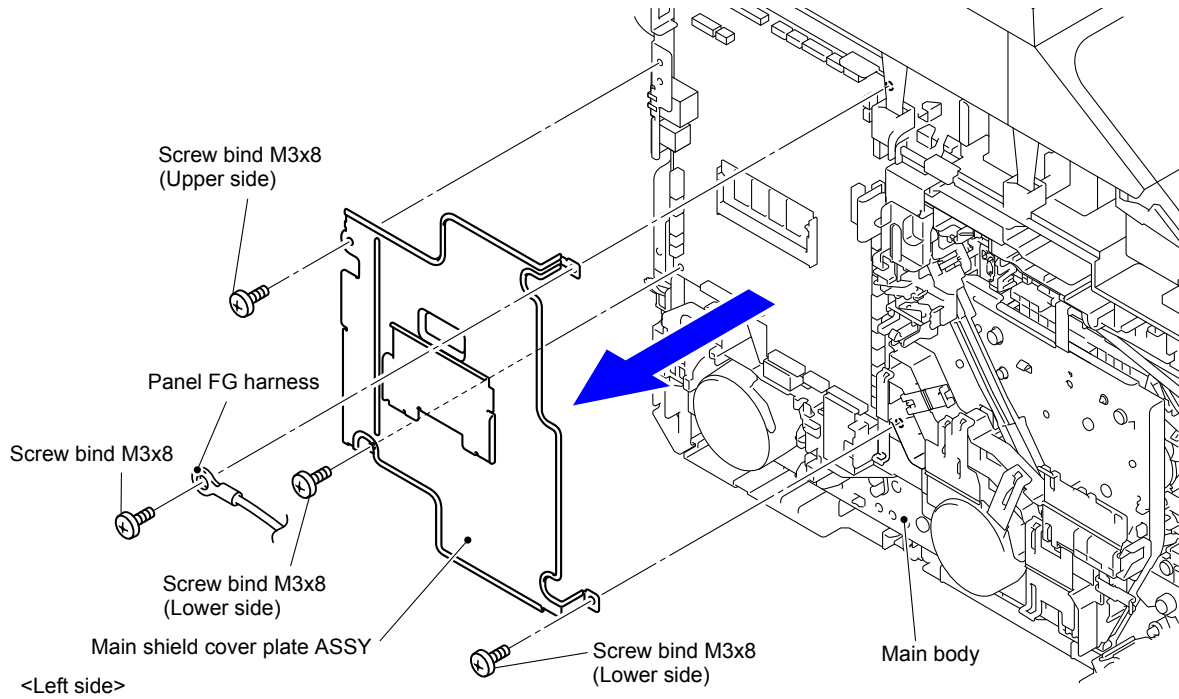

Fig. 3-64

Note:

Note that the tightening torque is different between the upper side and lower side of the Screw bind M3x8.

Upper side: 0.5 ± 0.05 N·m

Lower side: 0.8 ± 0.1 N·m

- (3) Remove the two Screw bind M3x8 screws and remove the ADF earth harness and Document scanner FG harness from the Main PCB plate.
- (4) Disconnect the two Connectors (CN39 and CN41) from the Main PCB ASSY and release the wiring of the Main PCB insulation sheet.

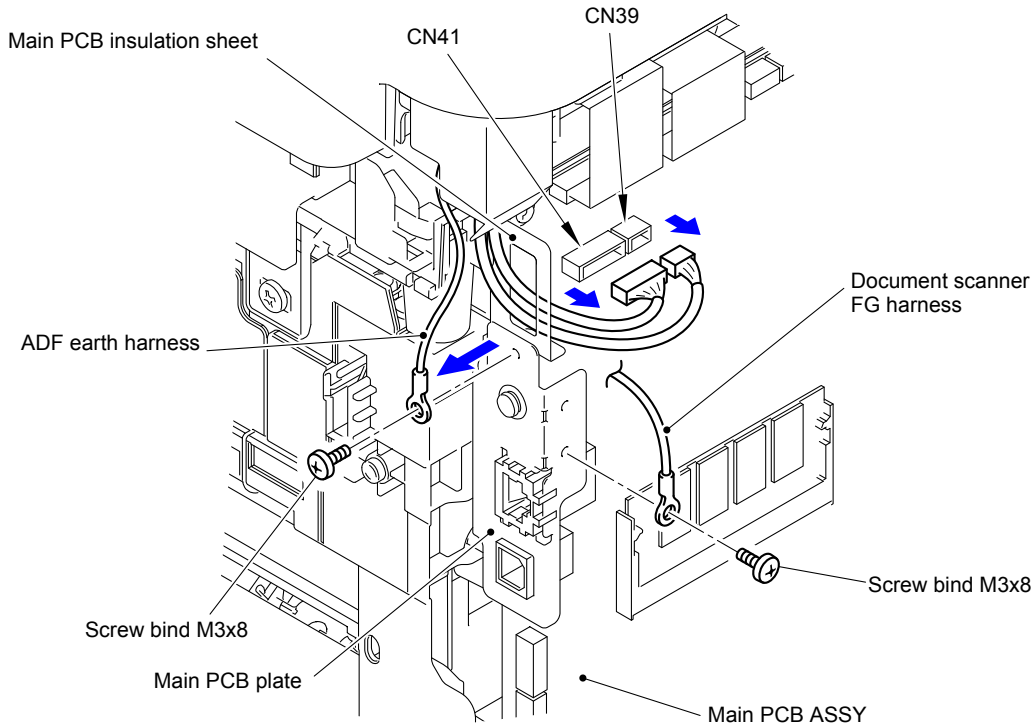

Fig. 3-65

- (5) Disconnect the four Connectors (CN20, CN27, CN32 and CN33) and two Flat cables (CN37 and CN38) from the Main PCB ASSY.

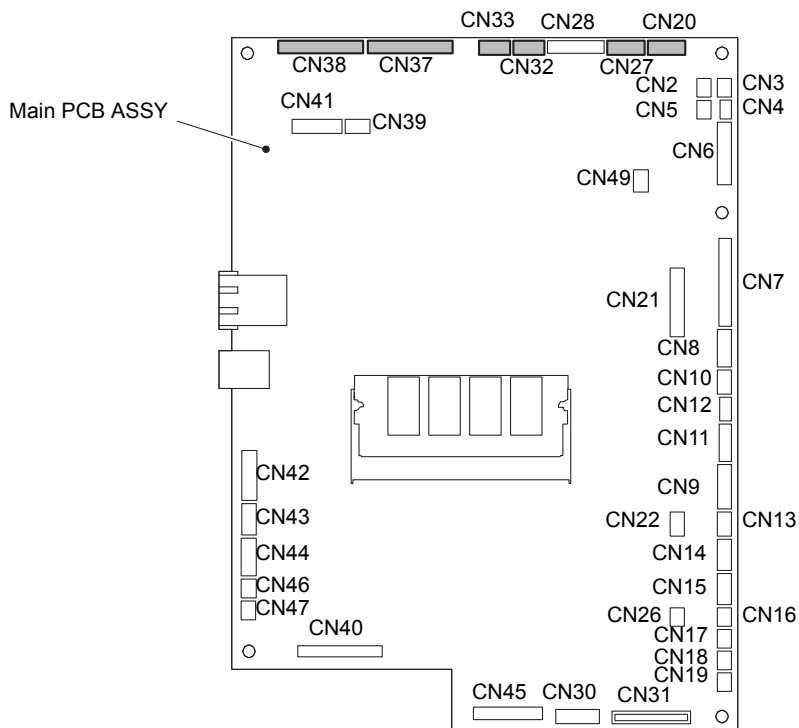

Fig. 3-66

- (6) Release all the wiring from the Document scanner unit.
- (7) Release the Hook and remove the Flat core from the Joint cover top.
- (8) Pull out the Second side CIS flat cable from the Flat core.

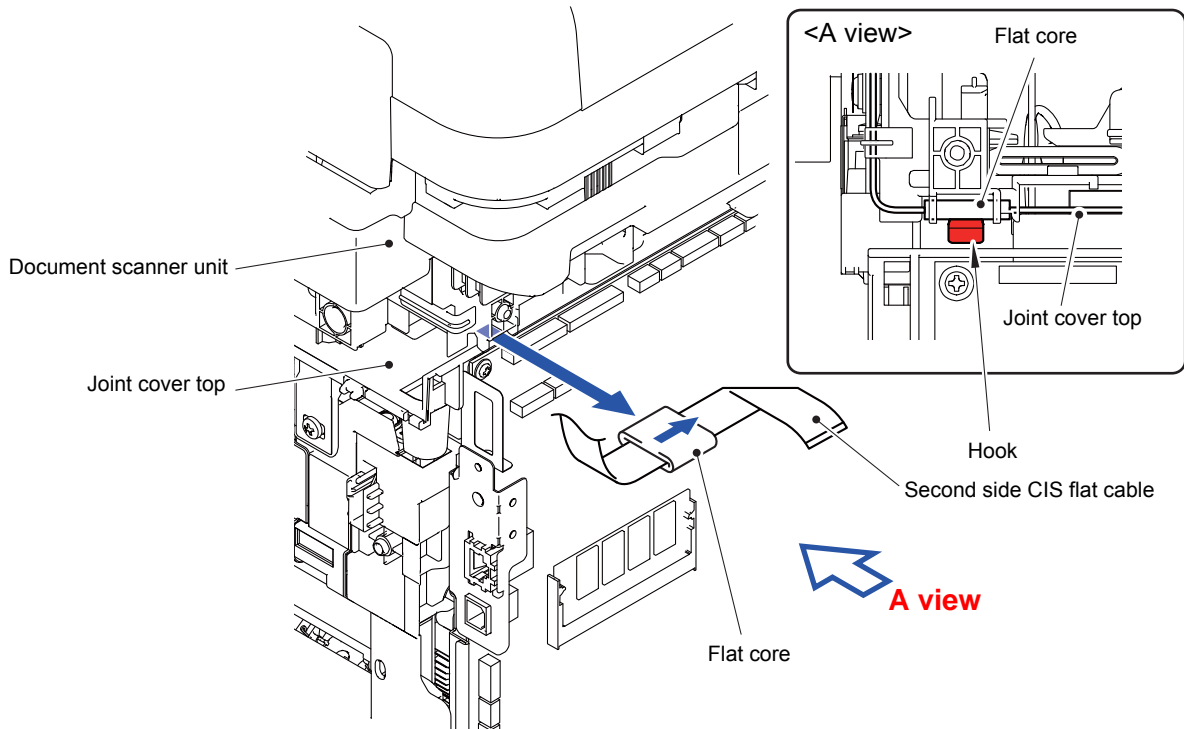

Fig. 3-67

- (9) Remove the two Taptite bind B M4x12 screws from the right side of the Main body.
- (10) Remove the two Taptite bind B M4x12 screws from the left side of the Main body.
- (11) Remove the two Taptite cup B M4x12 screws from the back side of the Main body.

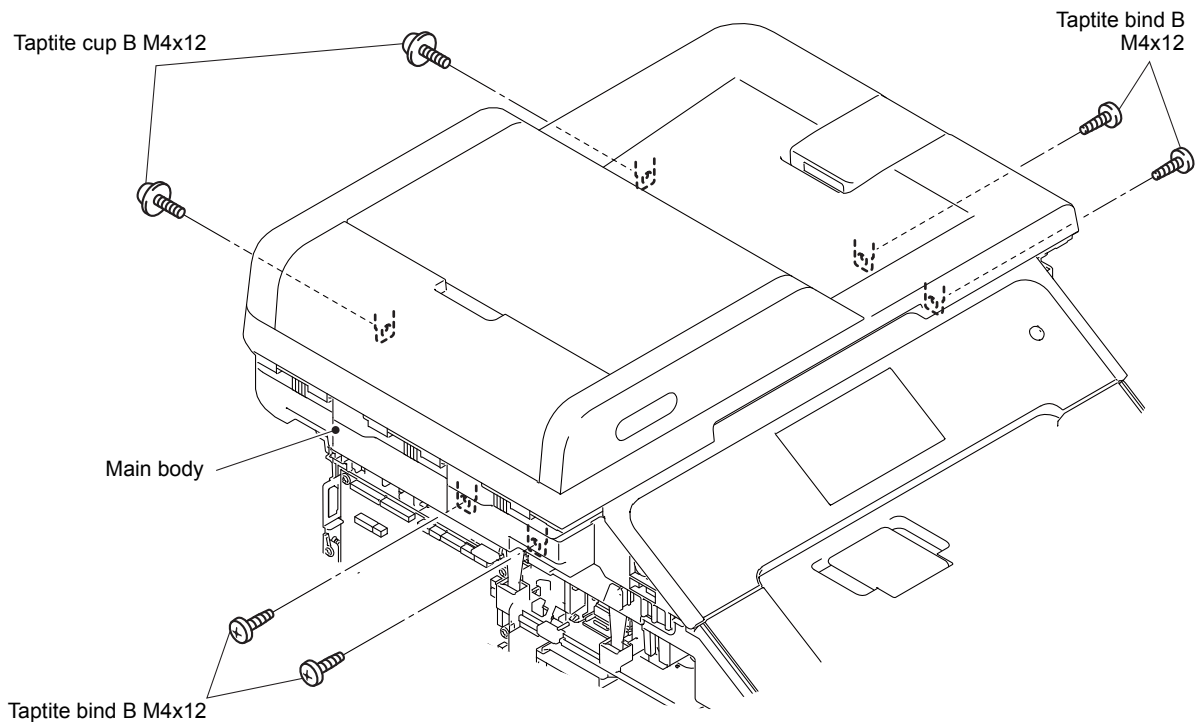

Fig. 3-68

- (12) Remove the eight Hooks and lift the Document scanner unit from the Main body.
- (13) Pull out the First side CIS flat cable from the Flat core of the Main body as lifting the Document scanner unit.

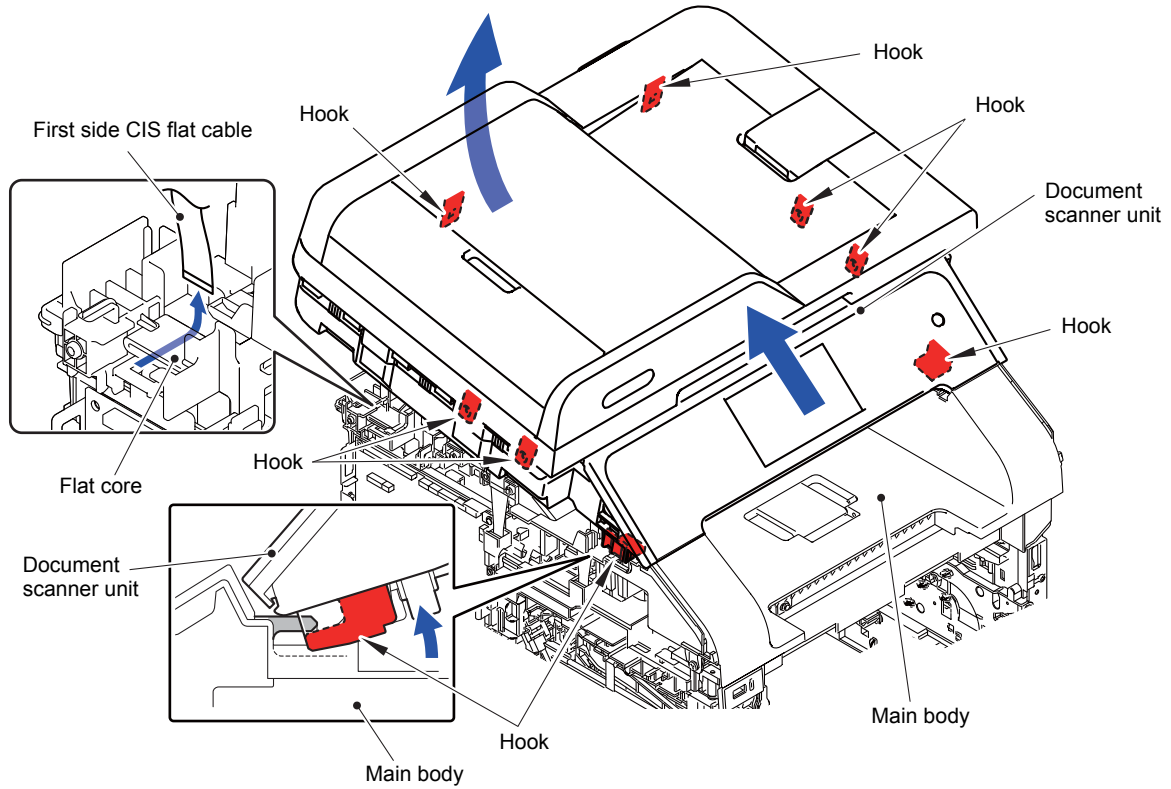

Fig. 3-69

- (14) Remove the two Taptite bind B M4x12 screws from the ADF unit.

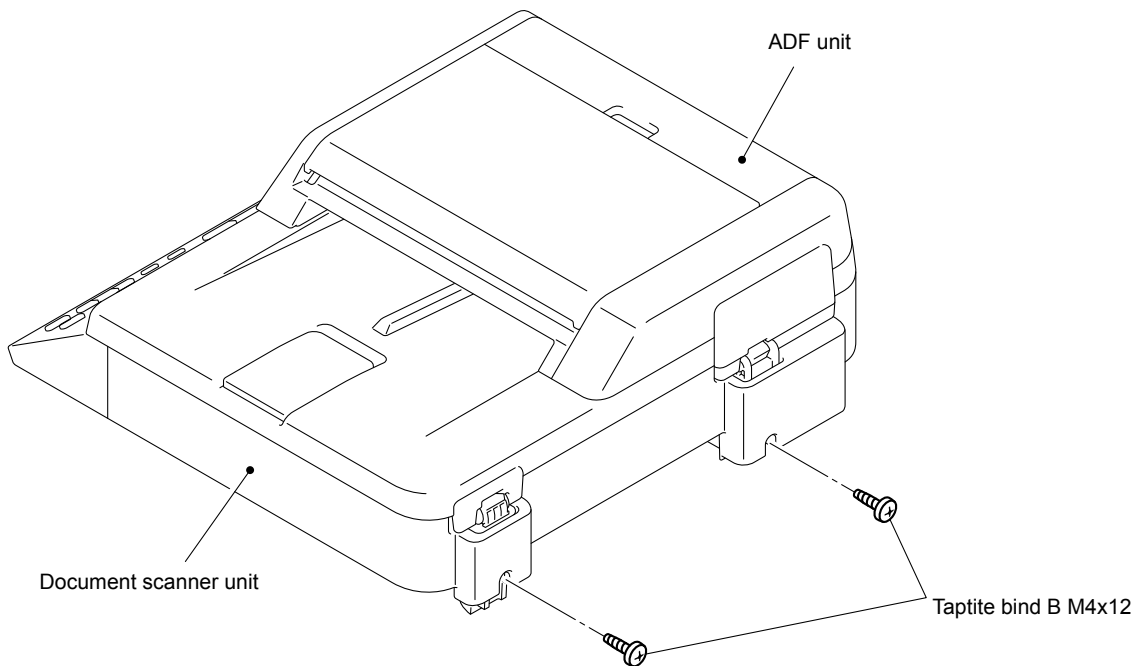

Fig. 3-70

- (15) Open the ADF unit.
- (16) Release the three Hooks and remove the Flat cable holder from the Document scanner unit.
- (17) Pull out the Harness of the ADF unit from the Hole of the Document scanner unit.
- (18) Remove the ADF unit from the Document scanner unit.

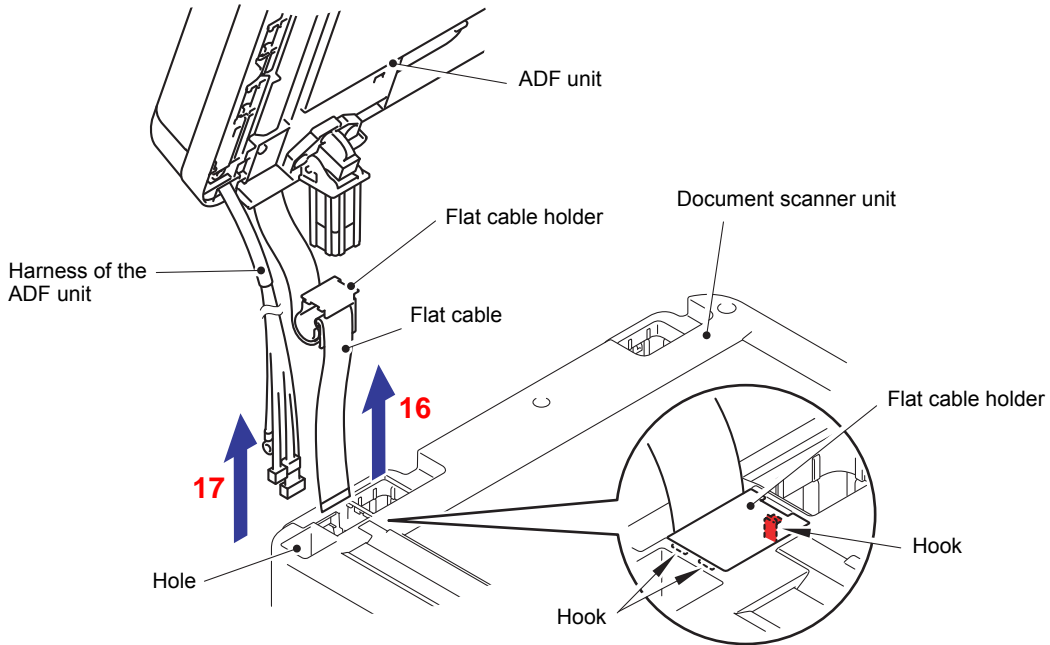

Fig. 3-71

Assembling Note:

- When assembling the Flat cable holder, take care not to accidentally damage the Hooks, which are easily get broken.
- When the ADF unit is replaced, be sure to fold and assemble the Second side CIS flat cable as shown in the figure.
- After disconnecting Flat cables, check that each cable is not damaged at its end or short-circuited.
- When connecting Flat cables, do not insert them at an angle. After insertion, check that the cables are not at an angle.

<How to fold the Second side CIS flat cable>

- Fold down
- Fold back

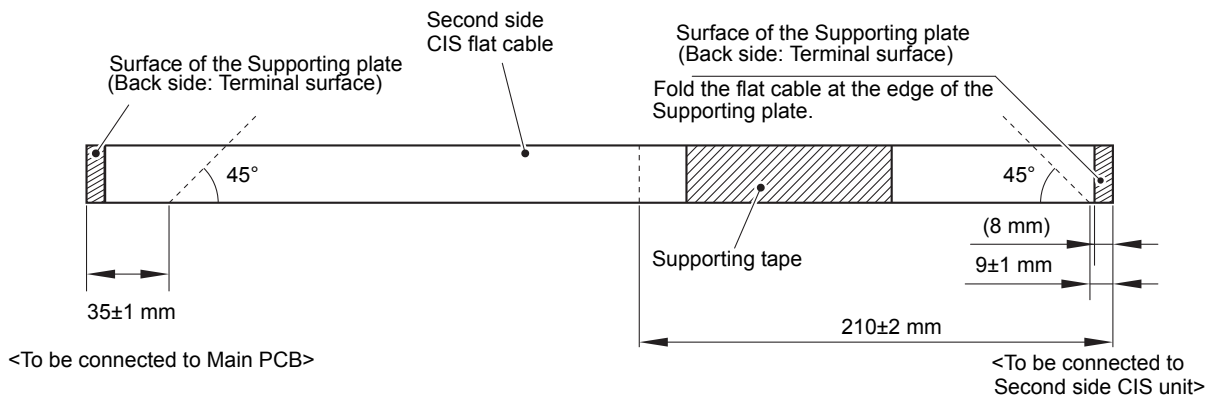

Fig. 3-72

(19) Turn the ADF unit upside down.

(20) Remove the three Taptite cup S M3x12 screws and remove the Hinge ASSY L from the ADF unit.

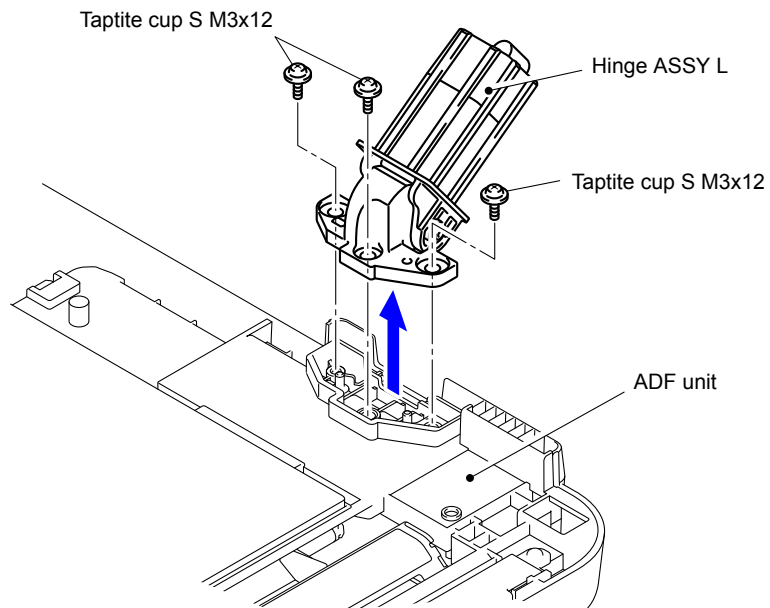

Fig. 3-73

(21) Remove the Taptite cup B M3x10 screw and remove the Hinge R and Hinge R support from the ADF unit.

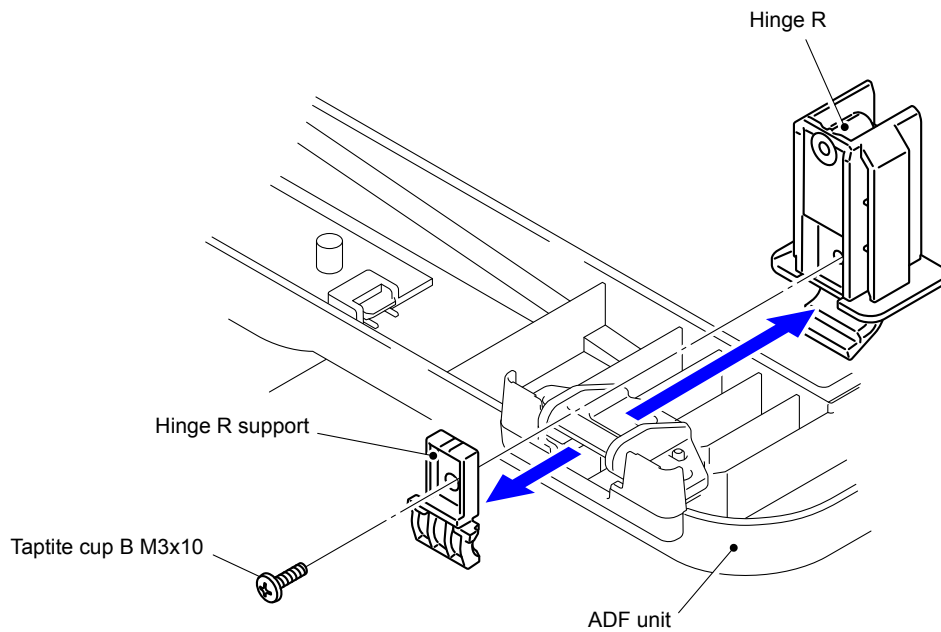

Fig. 3-74

Harness routing: Refer to “[14 ADF \(Legal model\)](#)”, “[16 Document Scanner Unit \(Legal model\)](#)”, “[18 Control Panel ASSY \(Legal model\)](#)”

9.18 ADF Document Output Support Flap

- (1) Turn the ADF unit right side up.
- (2) Release the two Pins and remove the ADF document output support flap from the ADF unit.

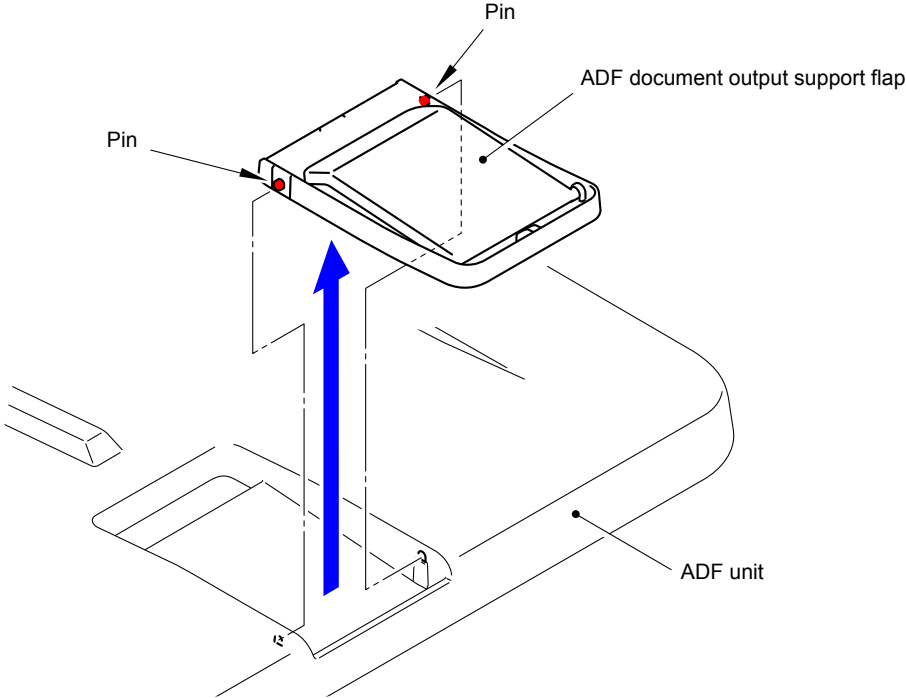

Fig. 3-75

9.19 ADF Document Support

- (1) Open the ADF document support.
- (2) Release the two Pins and remove the ADF document support from the ADF unit.

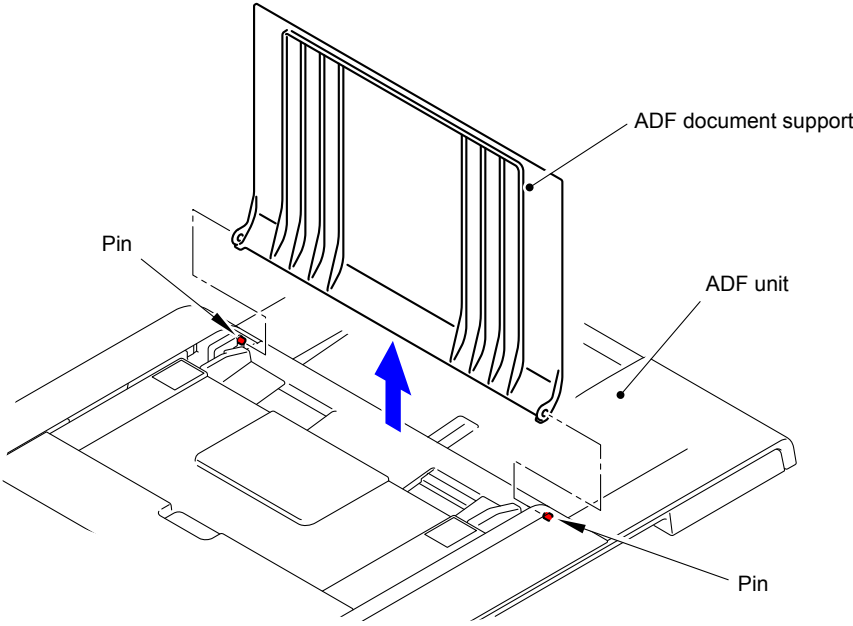

Fig. 3-76

9.20 ADF Cover ASSY

- (1) Open the ADF cover ASSY.
- (2) Release the two Pins and remove the ADF cover ASSY from the ADF unit.

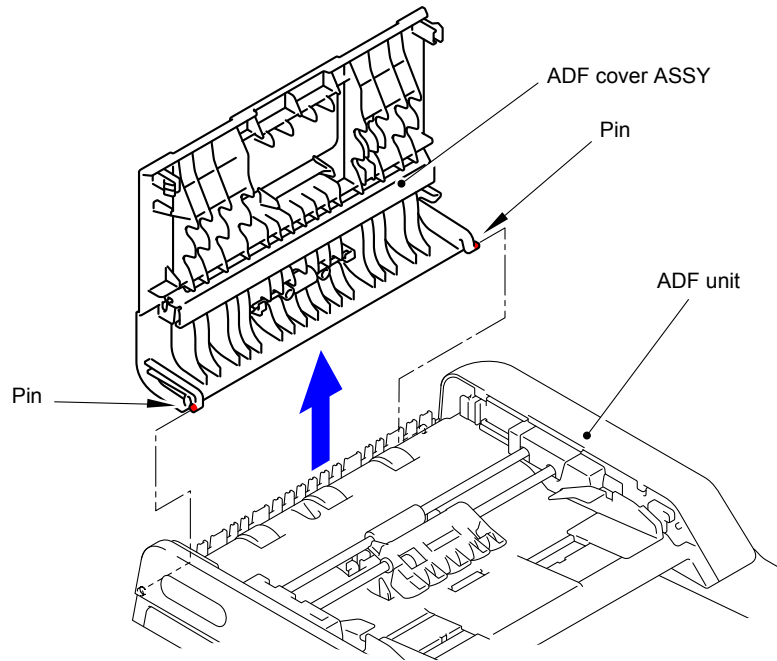

Fig. 3-77

9.21 Gear Cover

■ A4 model

(1) Release the two Hooks of the ADF unit.

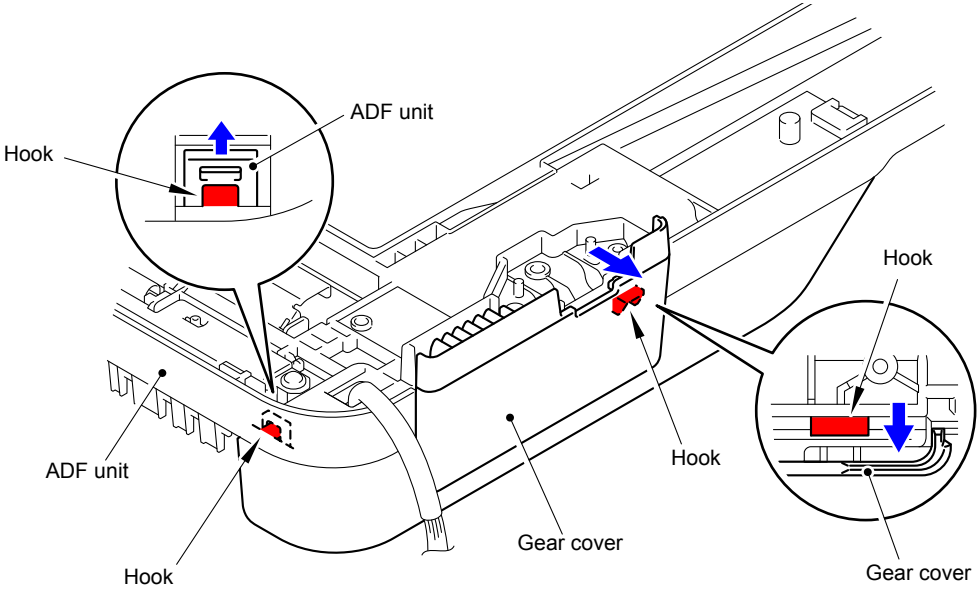

Fig. 3-78

■ Legal model

(1) Release the three Hooks of the ADF unit.

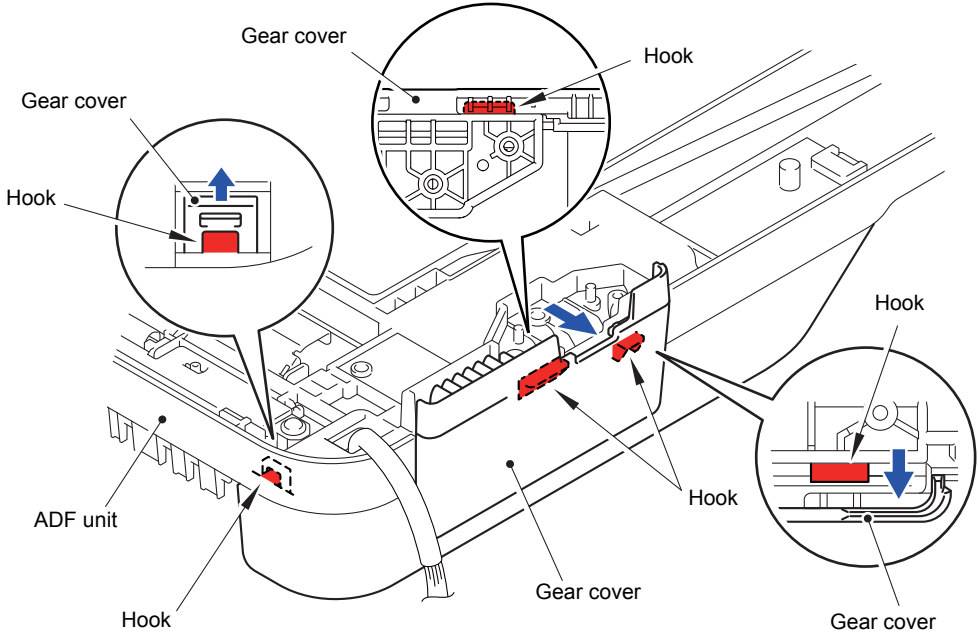

Fig. 3-79

Assembling Note:

When assembling the Gear cover, take care not to accidentally damage the Hooks shown in the figure.

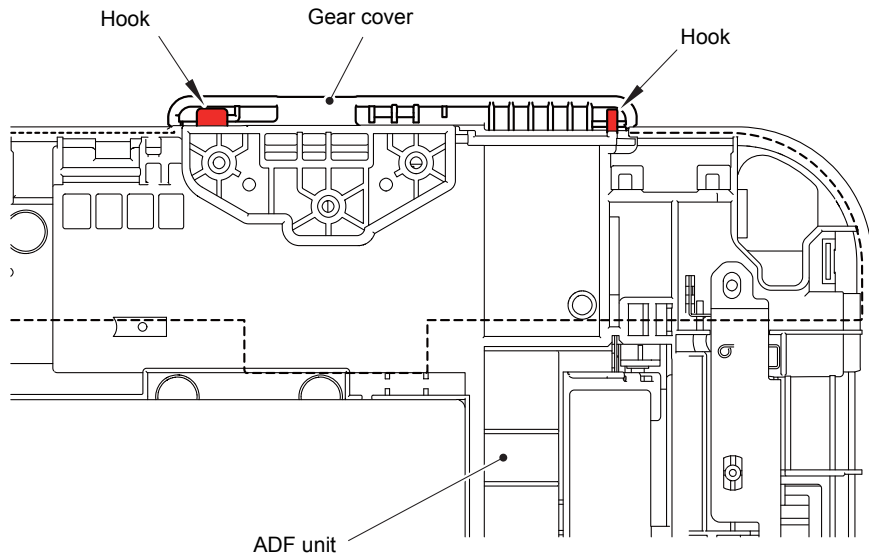

Fig. 3-80

■ **A4 model/Legal model**

- (2) Remove the Gear cover from the ADF unit.

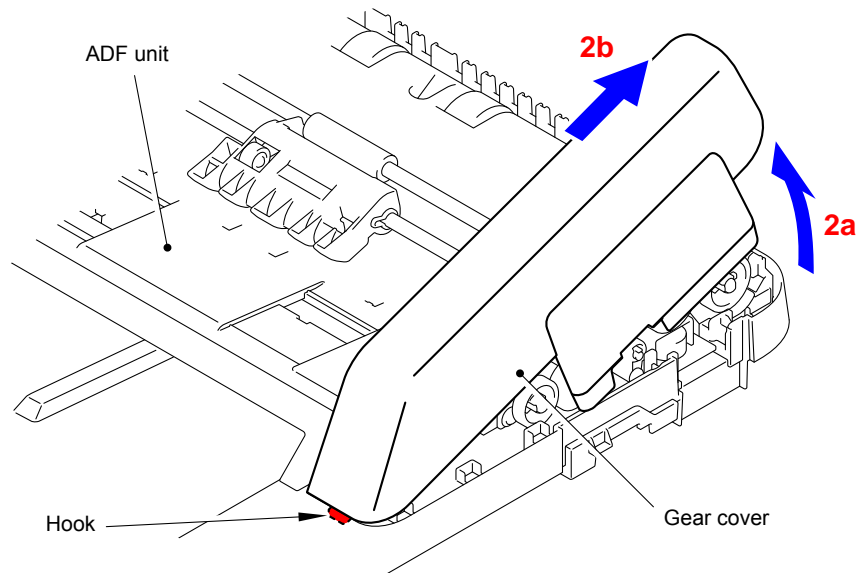

Fig. 3-81

9.22 Separation Roller

(1) Rotate the Conductive bushing to release the lock.

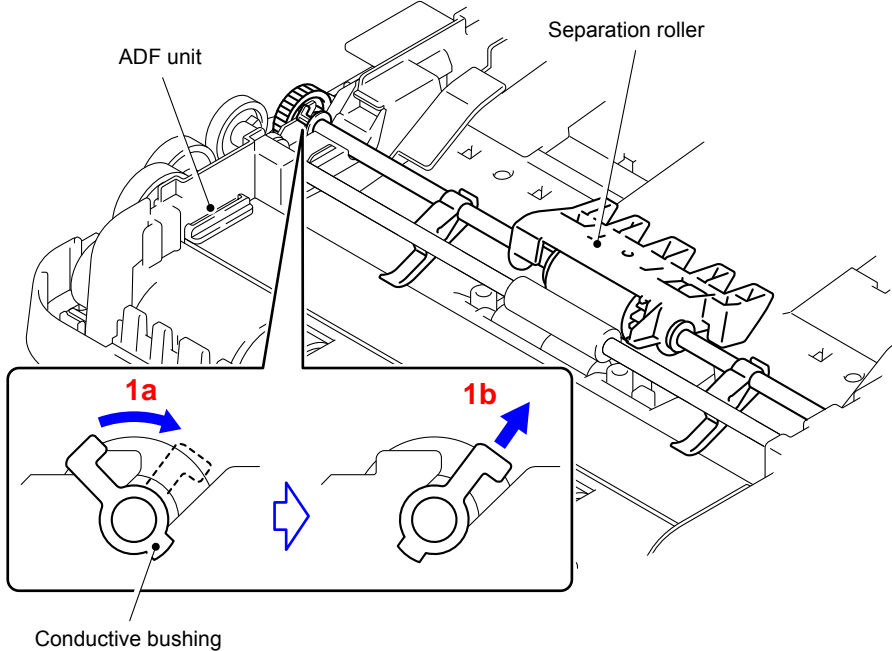

Fig. 3-82

(2) Remove the Separation roller from the ADF unit.

Note:
When removing the Separation roller, be careful not to damage the Flap ADF.

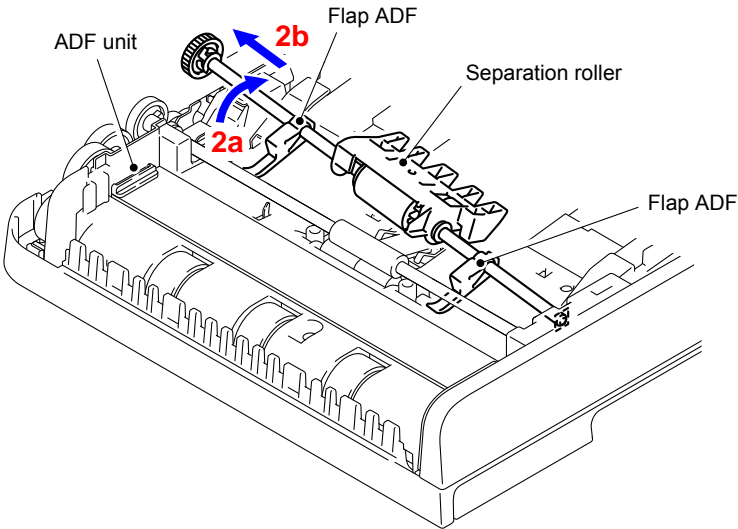

Fig. 3-83

Assembling Note:

When assembling the Separation roller, be sure to assemble it in a way that the Flap ADF comes under the Document feed roller ASSY 1.

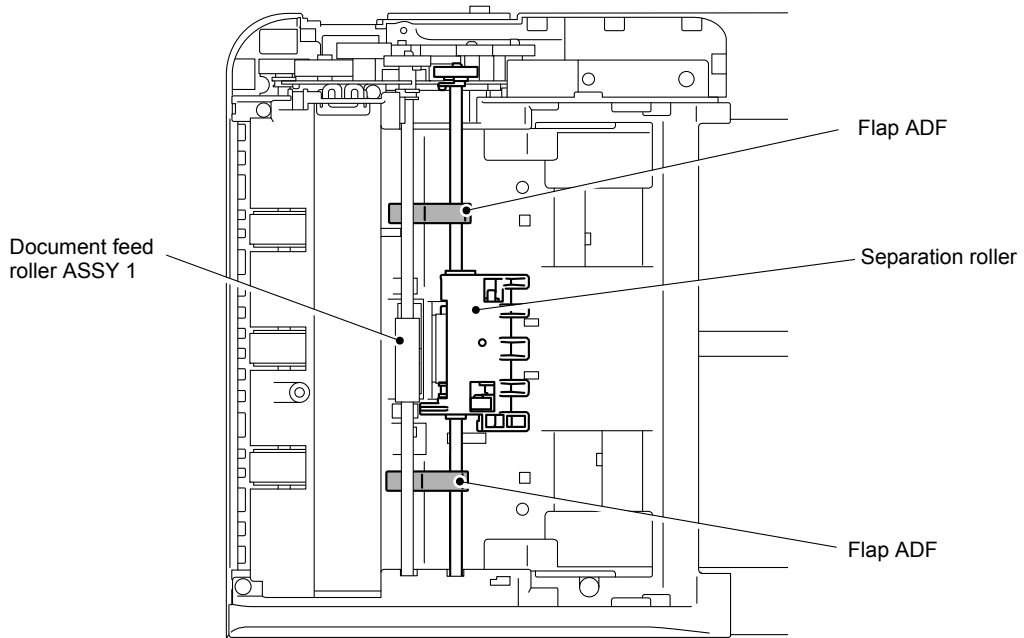

Fig. 3-84

9.23 ADF Separation Pad Holder (A4 Model Only)

(1) Remove the two Pins and remove the ADF separation pad holder from the Upper ADF chute.

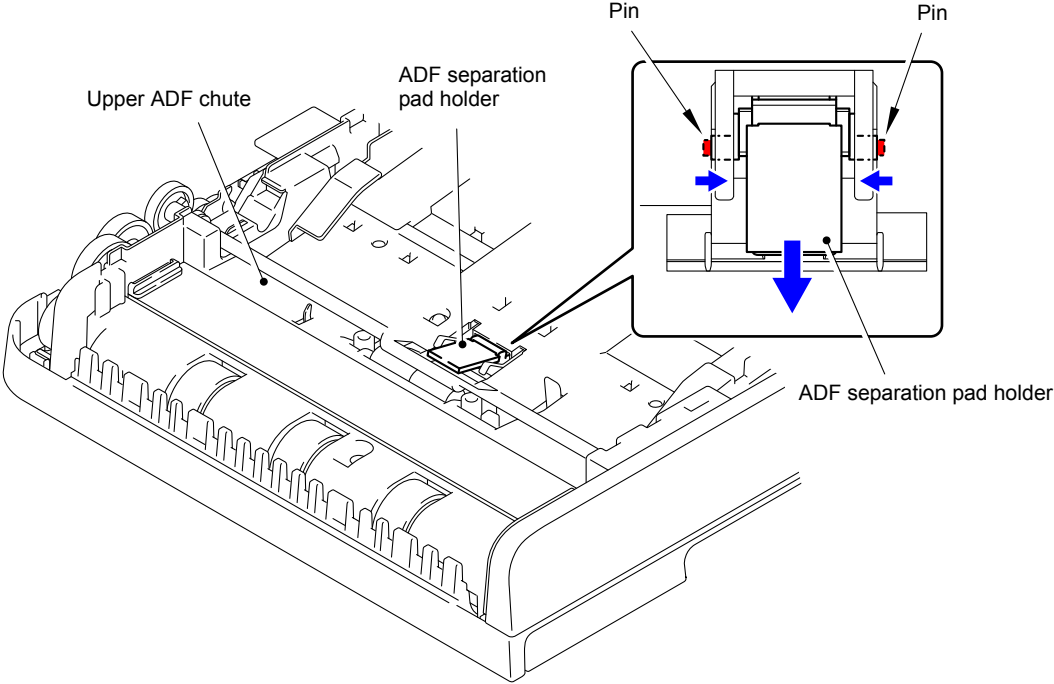

Fig. 3-85

Note:
Be careful not to lose the ADF spring.

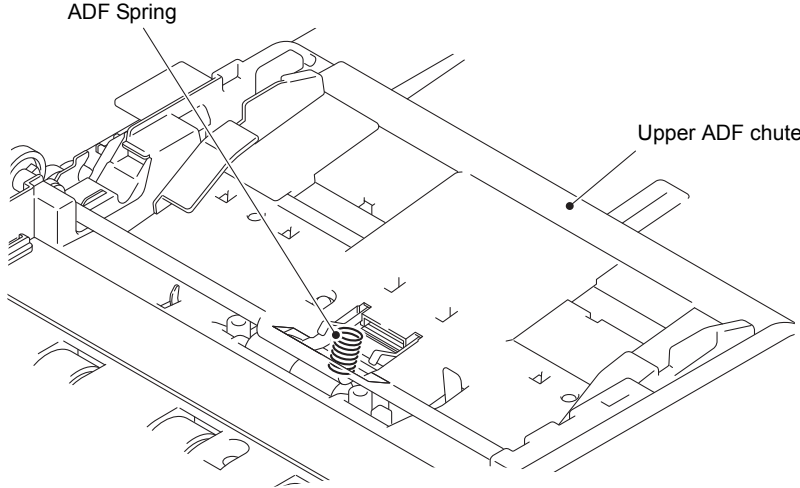

Fig. 3-86

Assembling Note:

There are cases where the ADF spring enters the Upper ADF chute from the mounting hole of the ADF separation pad holder. In this case, remove the Upper ADF chute from the ADF unit and take out the ADF spring. In the case that the Upper ADF chute has been removed, be sure to assemble the ADF spring and ADF separation pad holder, and then assemble the Upper ADF chute to the ADF unit.

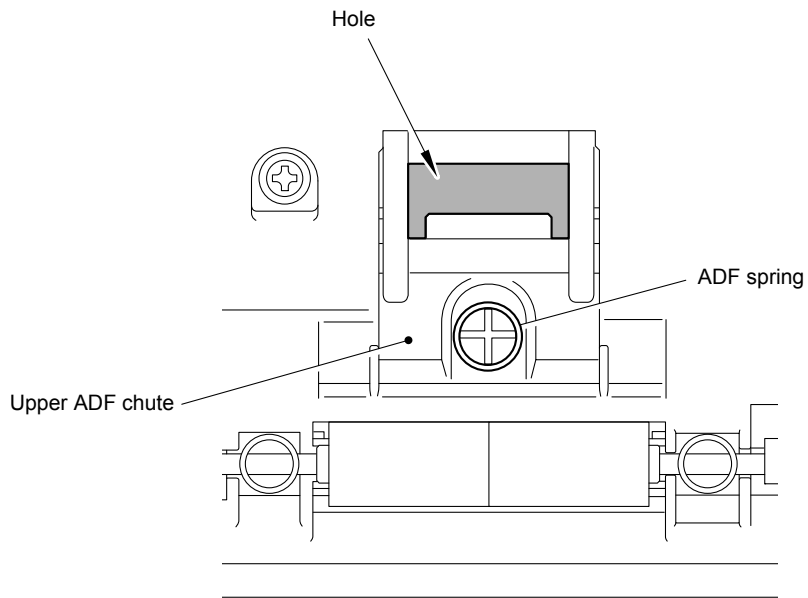

Fig. 3-87

9.24 ADF Separation Pad/ Separation Support Film (Legal Model Only)

(1) Remove the Taptite cup B M3x10 screw from the Upper ADF chute.

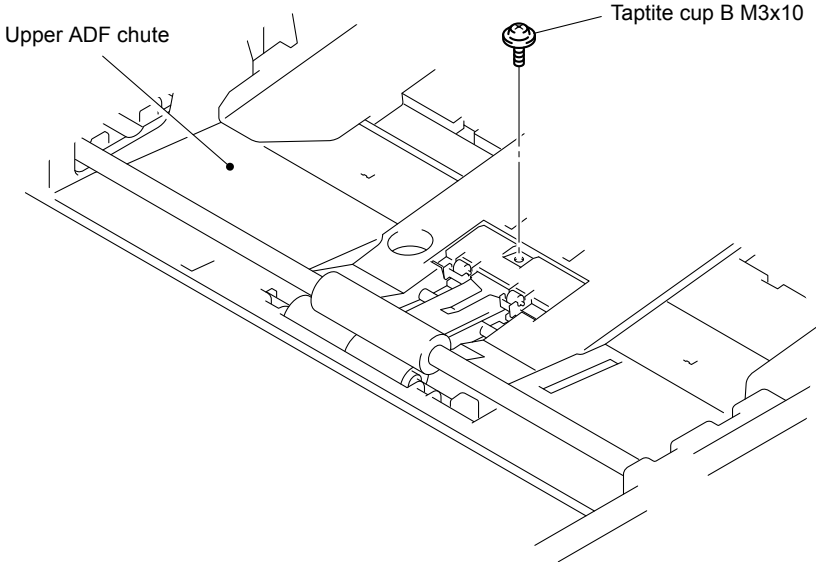

Fig. 3-88

(2) Release the two Hooks and remove the Separation rubber holder ASSY from the Upper ADF chute.

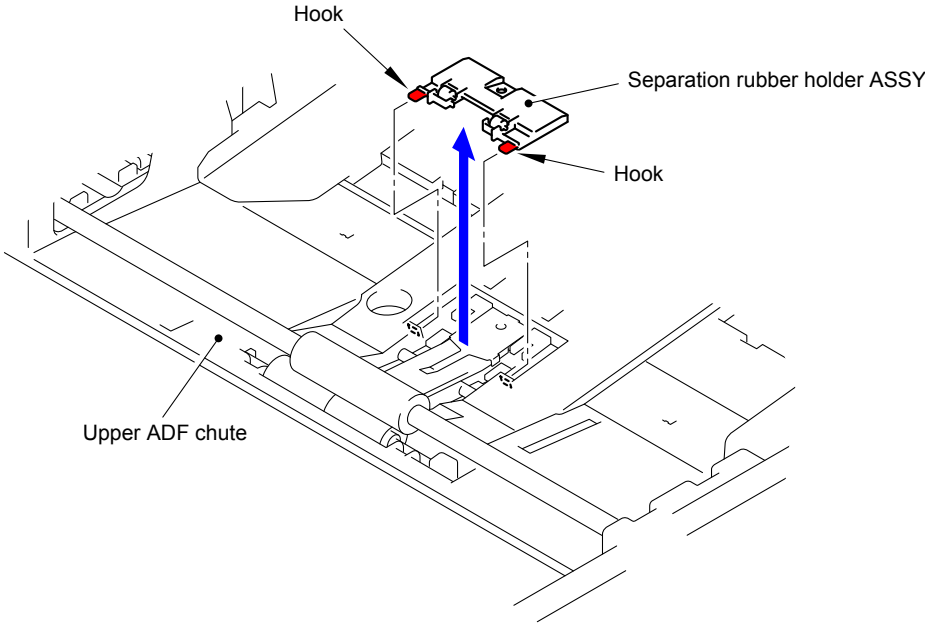

Fig. 3-89

(3) Remove the Separation support film and ADF separation pad from the Upper ADF chute.

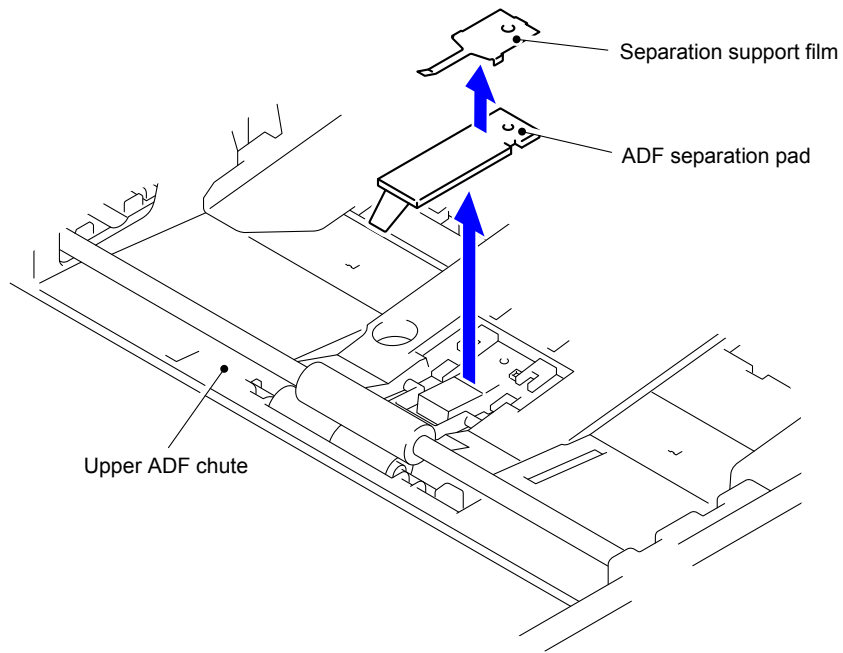

Fig. 3-90

Note:

If the edge of the Separate support film protrudes from the Upper ADF chute, it causes noise.

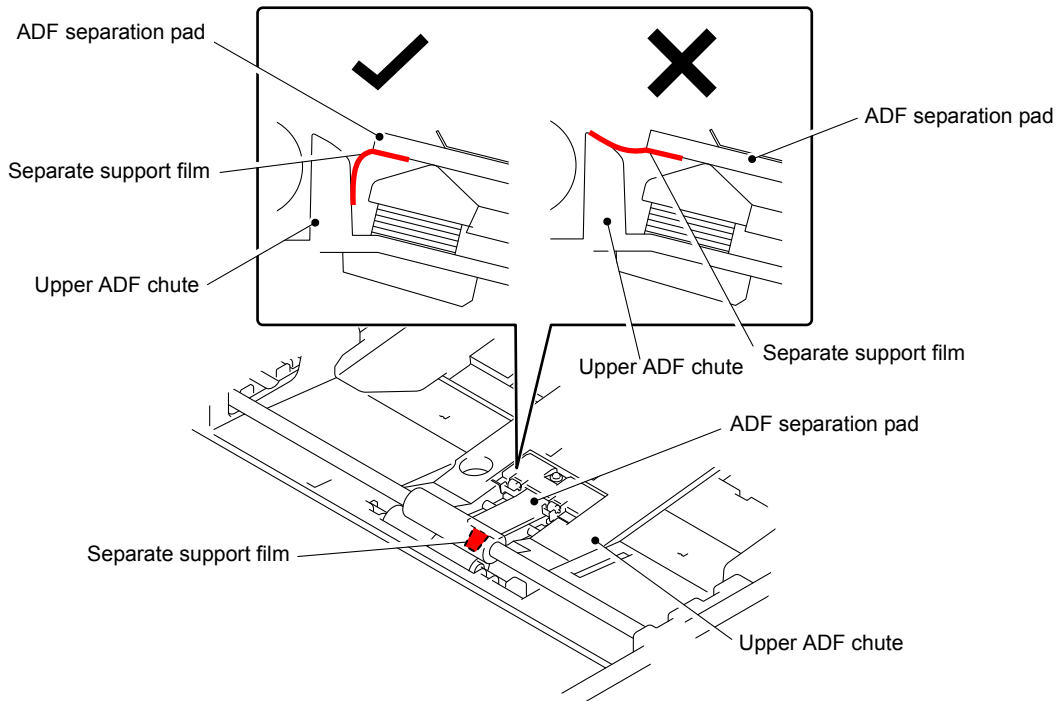

Fig. 3-91

(4) Remove the Separate support film from the ADF separation pad.

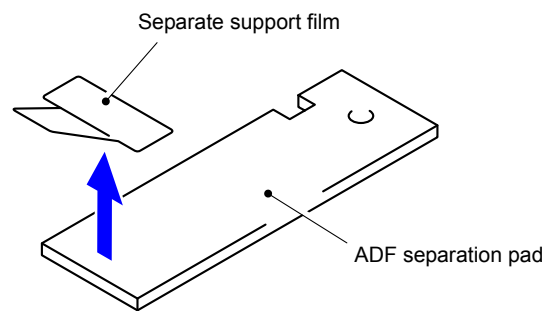

Fig. 3-92

Note:

When the ADF separation pad is replaced, the Separate support film need to be replaced.

9.25 ADF Separation Spring Holder (Legal Model Only)

(1) Release the Hook of the ADF separation spring holder.

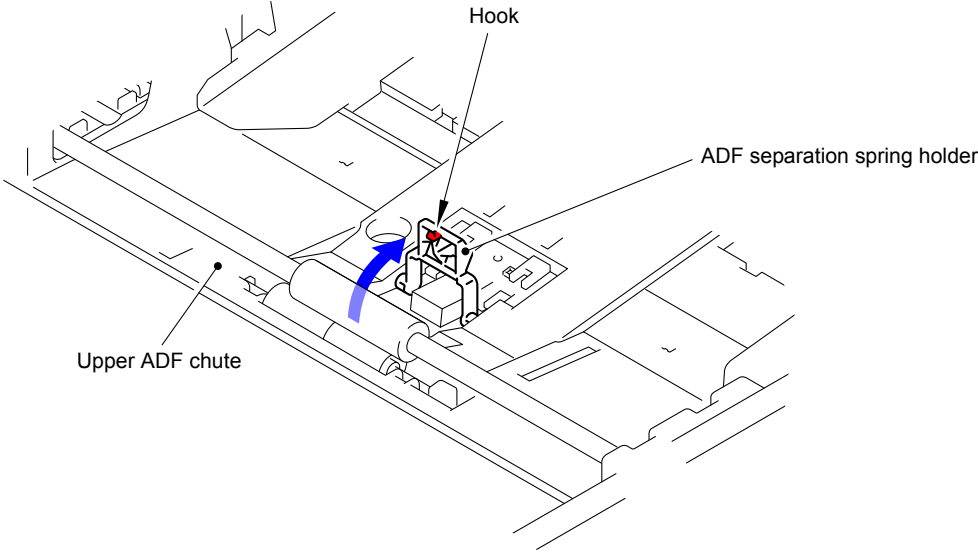

Fig. 3-93

(2) Remove the two Pins and remove the ADF separation spring holder from the Upper ADF chute.

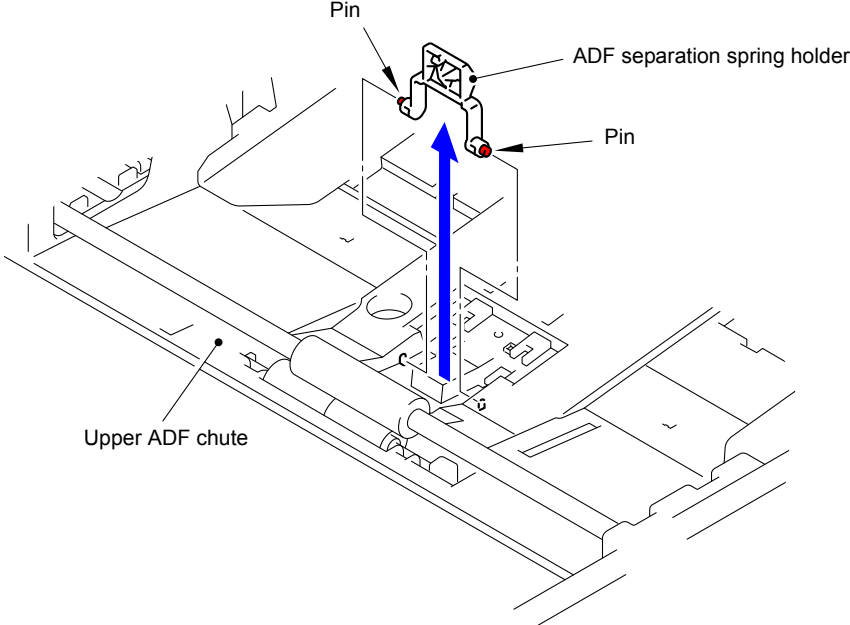

Fig. 3-94

(3) Remove the ADF spring from the Upper ADF chute.

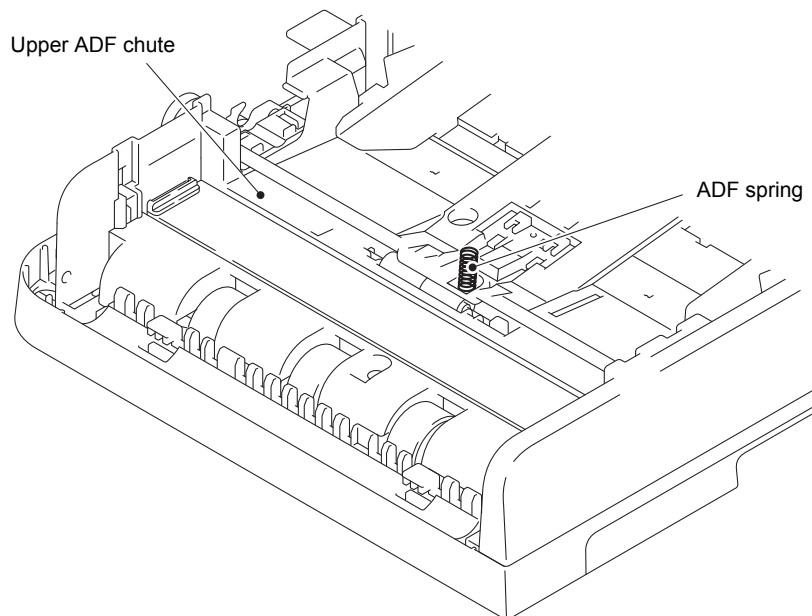

Fig. 3-95

9.26 CIS Spacer

Note:
Disassemble it in a place without dust.

- (1) Release the two Hooks and remove the CIS glass stopper from the ADF unit.

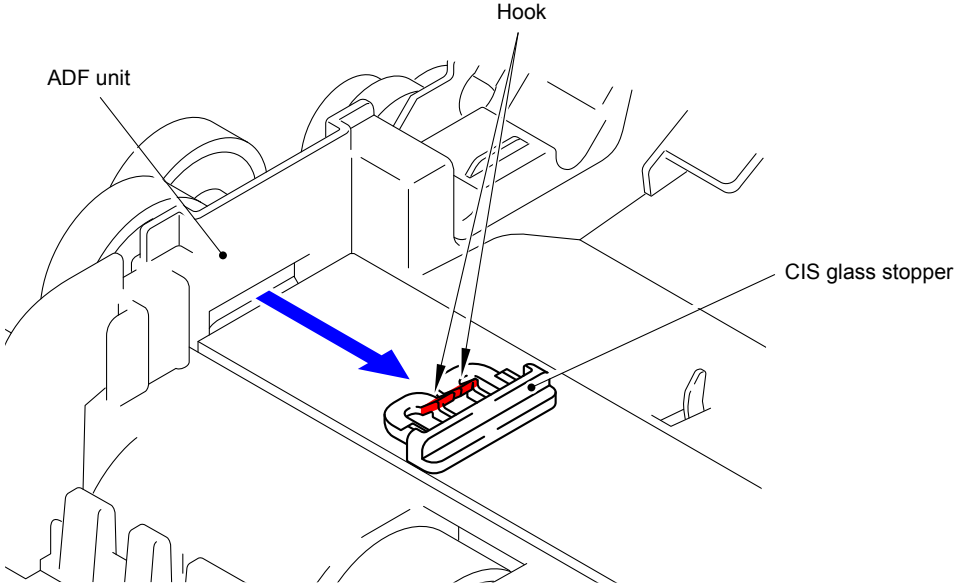

Fig. 3-96

- (2) Remove the CIS glass from the ADF unit.

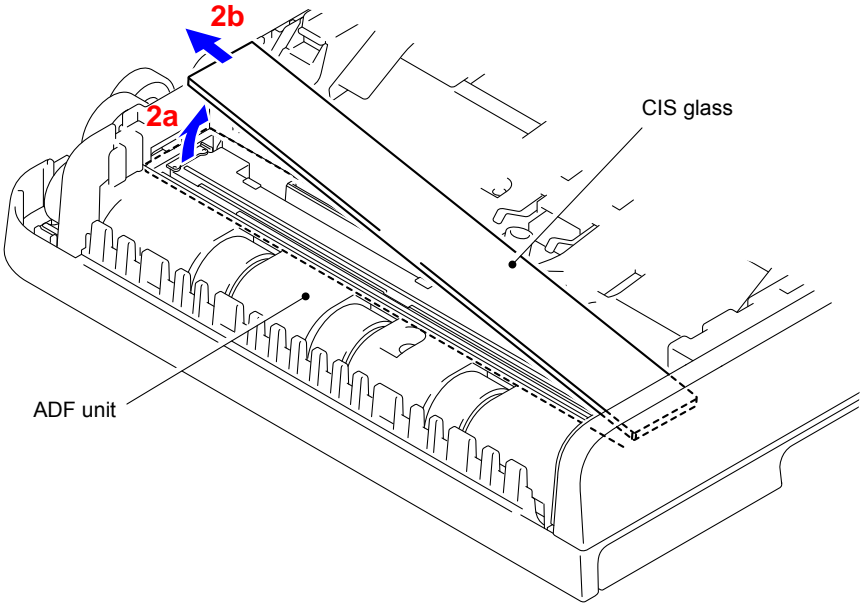

Fig. 3-97

(3) Remove the CIS spacer from the both ends of the Second side CIS unit.

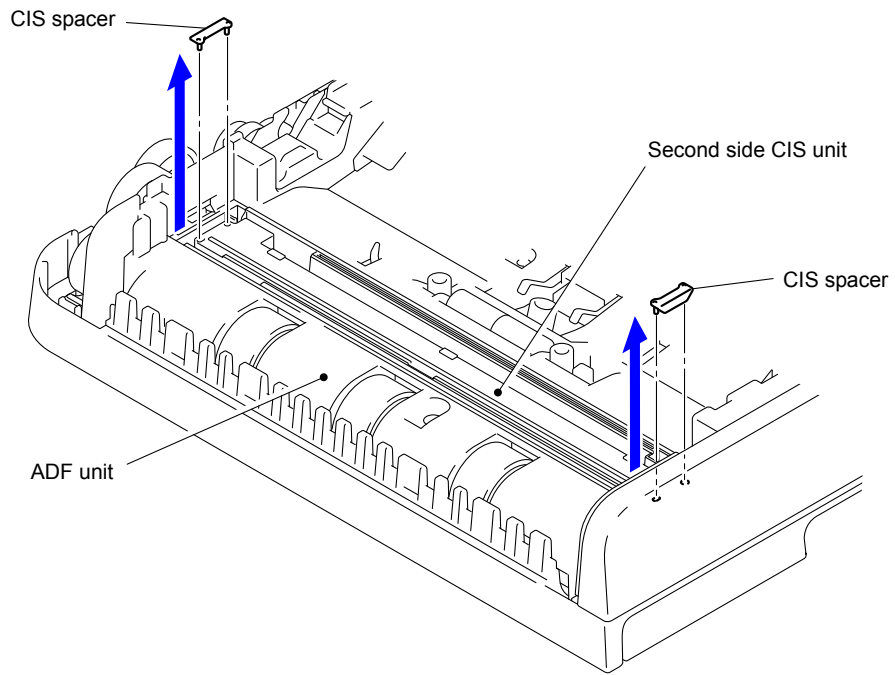

Fig. 3-98

9.27 Second Side CIS Flat Cable/Second Side CIS Unit

(1) Lift the Second side CIS unit and release the Second side CIS flat cable.

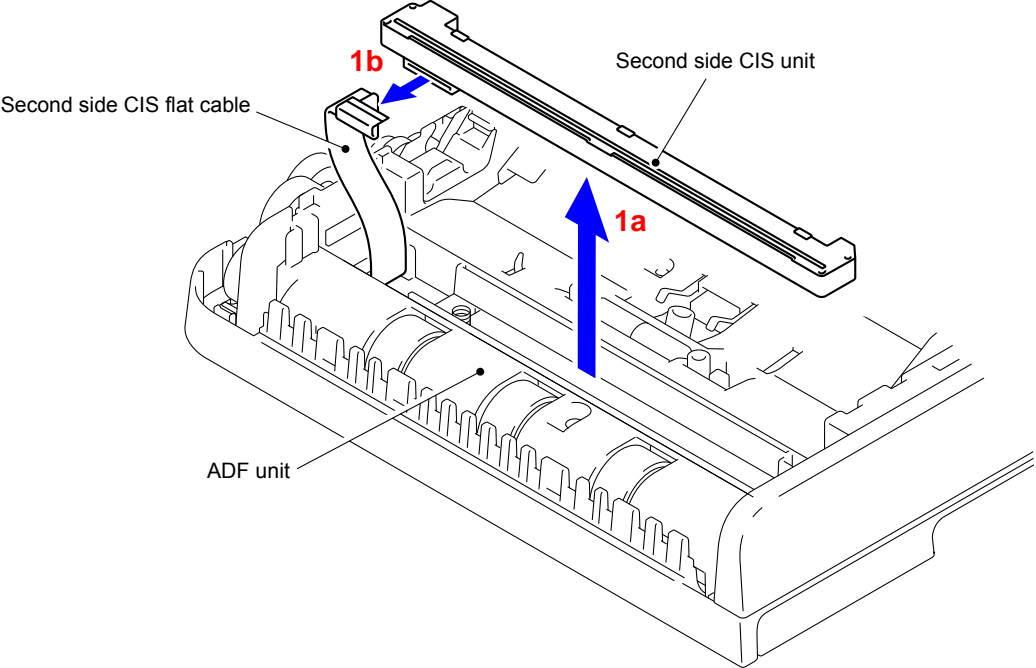

Fig. 3-99

(2) Remove the two CIS springs from the ADF unit.

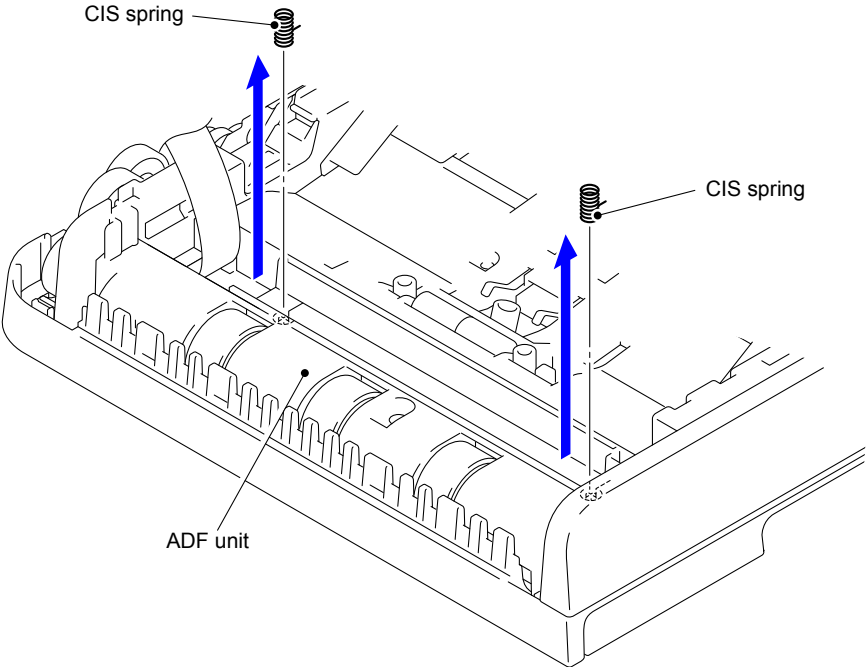

Fig. 3-100

(3) Remove the Second side CIS flat cable from the ADF unit.

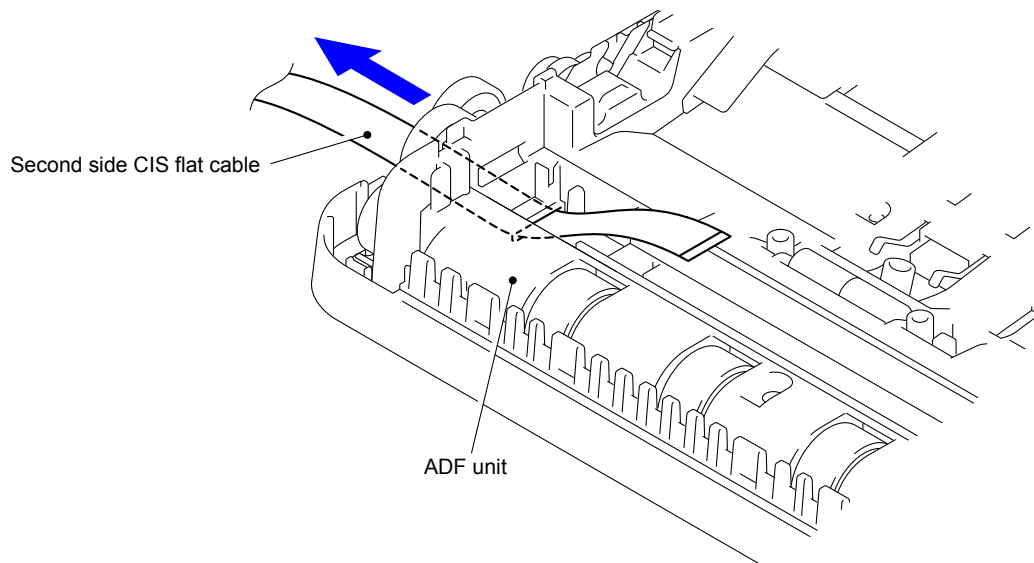

Fig. 3-101

Assembling Note:

Since the Second side CIS flat cable might be broken when you remove it from the Flat cable holder, be sure to replace it with a new Second side CIS flat cable. When assembling a new Second side CIS flat cable, be sure to assemble it in accordance with the following procedure.

<Assembling procedure>

- (1) Fold the Second side CIS flat cable at the Second side CIS unit side as shown in the how-to-fold figure below.

■ A4 model

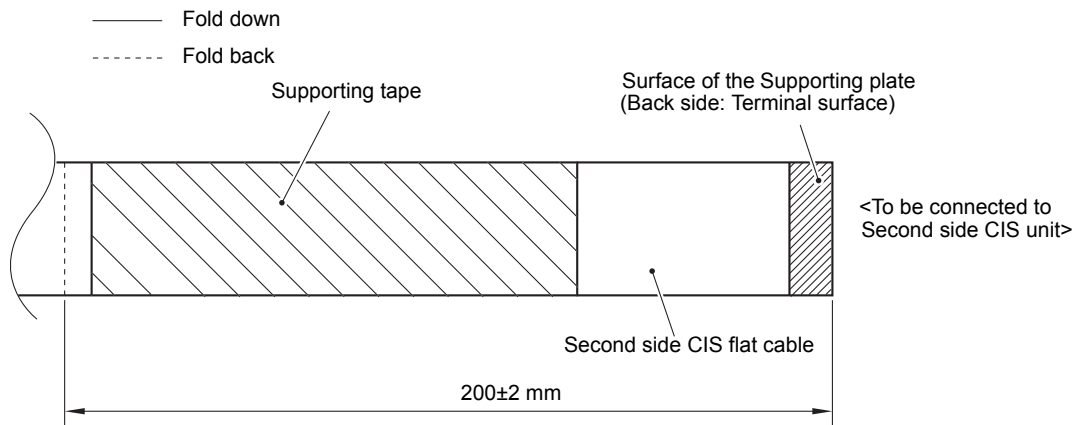

Fig. 3-102

■ Legal model

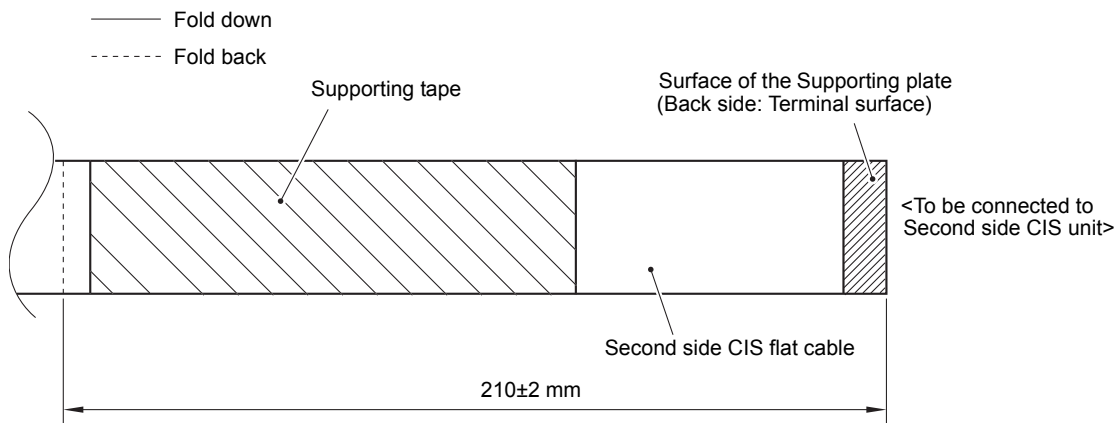

Fig. 3-103

- (2) Fold the Second side CIS flat cable at the Second side CIS unit side as shown in the how-to-fold figure below.

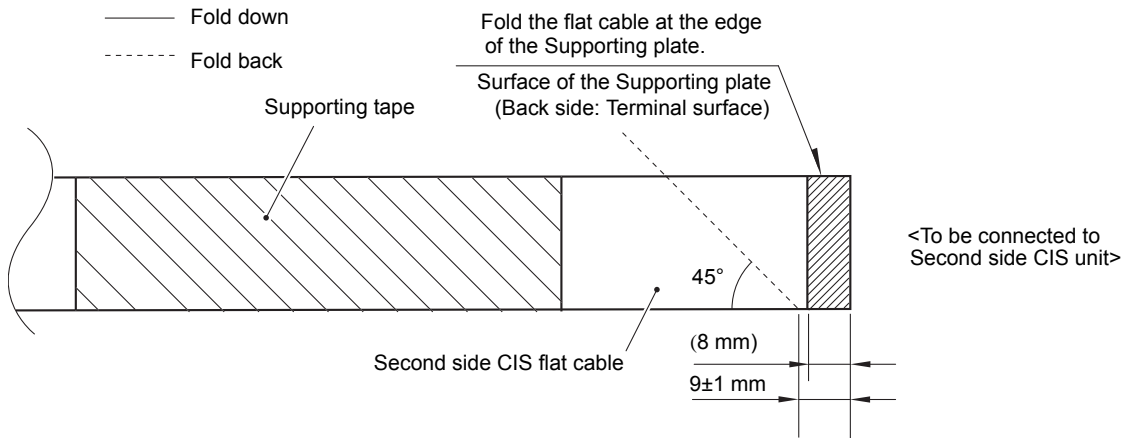

Fig. 3-104

- (3) Mount the Second side CIS flat cable at the Second side CIS unit side to the Second side CIS unit.

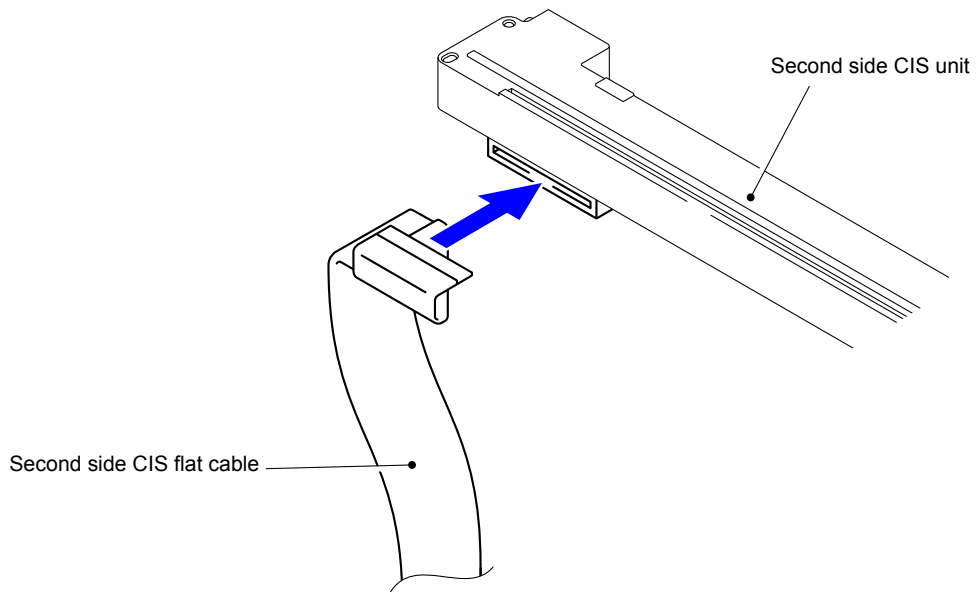

Fig. 3-105

- (4) Pass the Second side CIS flat cable through the ADF unit.

Note:

Remove the Upper ADF chute from the ADF unit in advance.
(Refer to “9.28 ADF Cover/Document Detection Sensor PCB ASSY/ First Side Document Scanning Position Sensor PCB ASSY/Second Side Document Scanning Position Sensor PCB ASSY (Duplex Scanning Model Only)” in this chapter.)

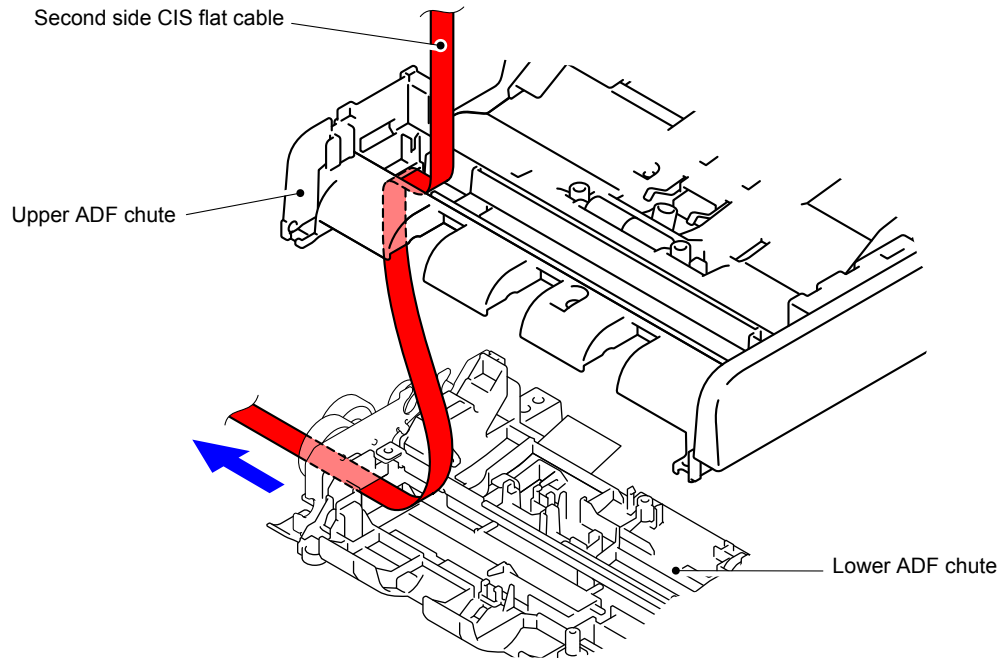

Fig. 3-106

- (5) Affix double-sided adhesive tape to the Flat cable holder as shown in the figure below.
(If the double-sided adhesive tape has already been affixed, be sure to remove it, and then affix new double-sided adhesive tape.)

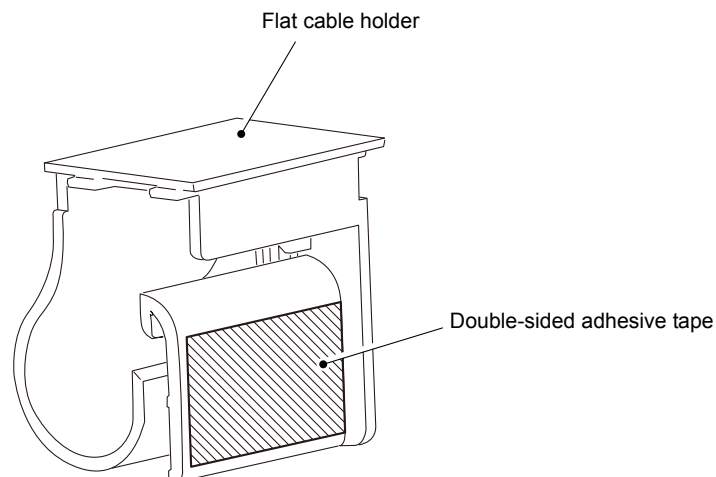

Fig. 3-107

- (6) Align the Second side CIS flat cable to the angle of the Rib of the Flat cable holder and pass it through the Flat cable holder as shown in the figure below, and then affix it to the double-sided adhesive tape affixed to the Flat cable holder.

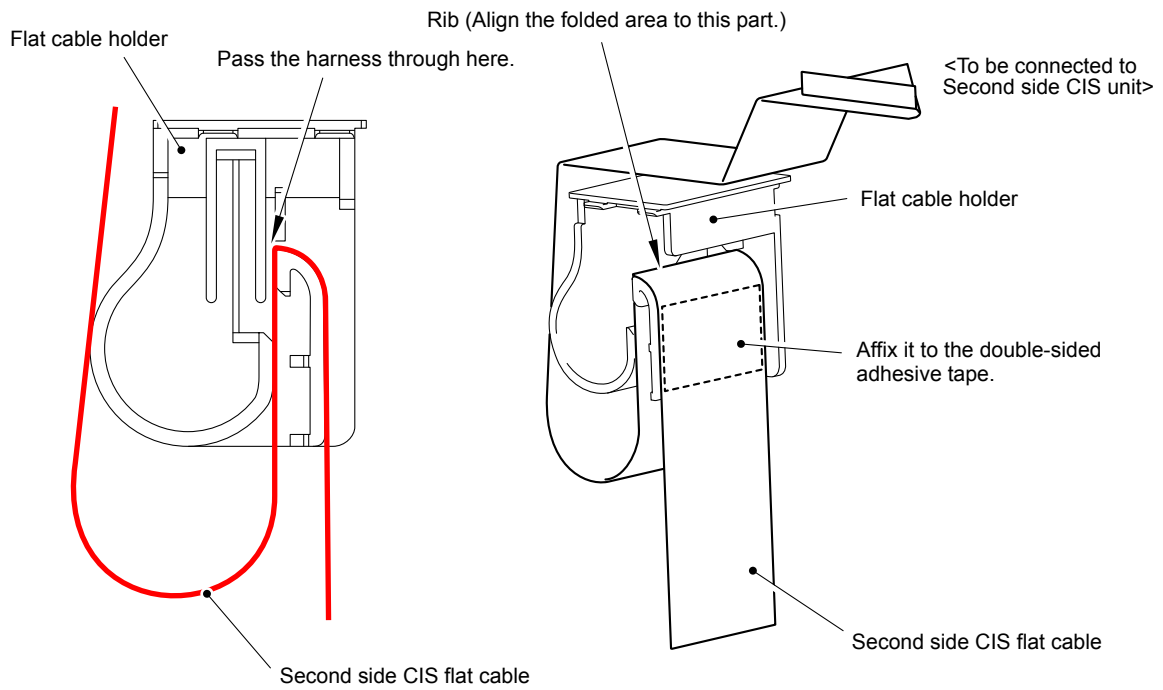

Fig. 3-108

(7) Fold the Second side CIS flat cable at the Main PCB ASSY side as shown in the how-to-fold figure below.

■ **A4 model**

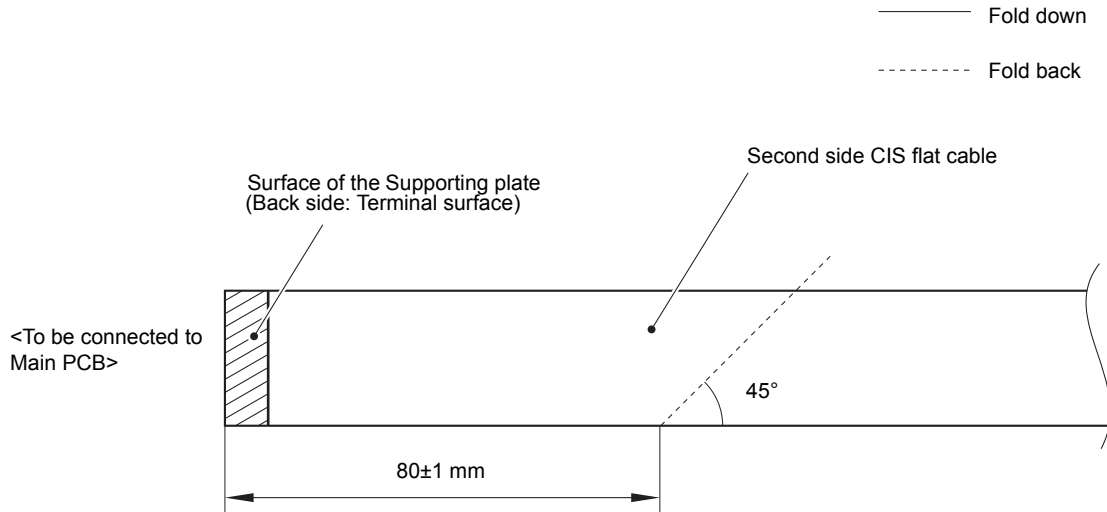

Fig. 3-109

■ **Legal model**

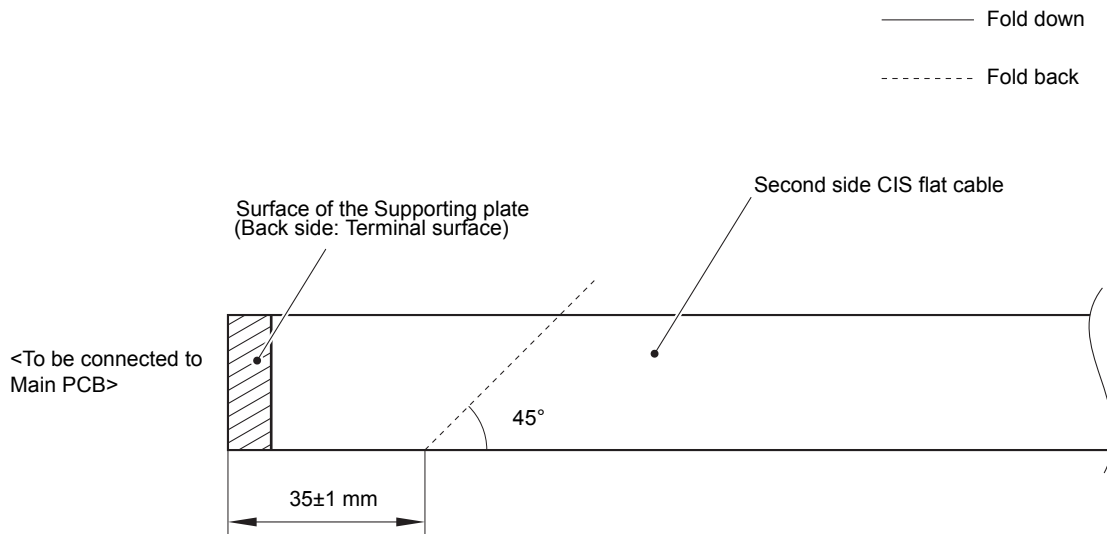

Fig. 3-110

Harness routing: Refer to “[13 ADF \(A4 model\)](#)”, “[14 ADF \(Legal model\)](#)”

9.28 ADF Cover/Document Detection Sensor PCB ASSY/ First Side Document Scanning Position Sensor PCB ASSY/ Second Side Document Scanning Position Sensor PCB ASSY (Duplex Scanning Model Only)

(1) Rotate the Conductive bushing to release the lock.

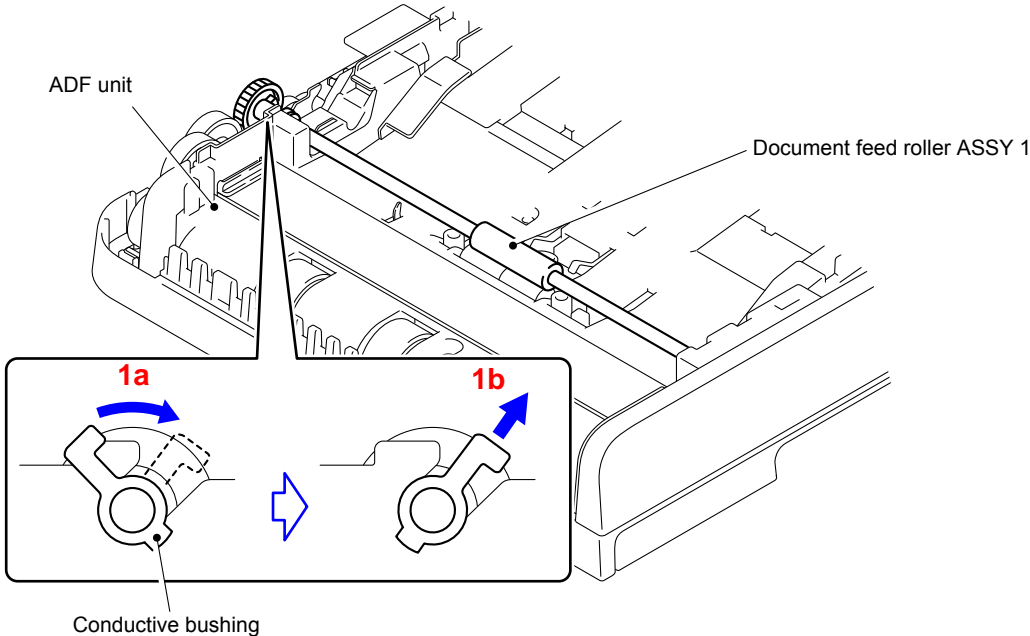

Fig. 3-111

(2) Remove the Document feed roller ASSY 1 from the ADF unit.

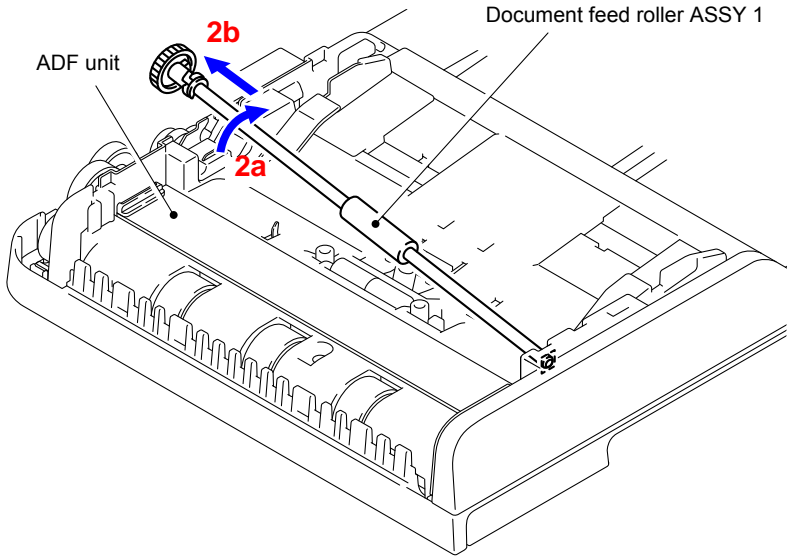

Fig. 3-112

- (3) Turn the ADF unit upside down.
- (4) Remove the Taptite cup B M3x10 screw from the ADF unit.

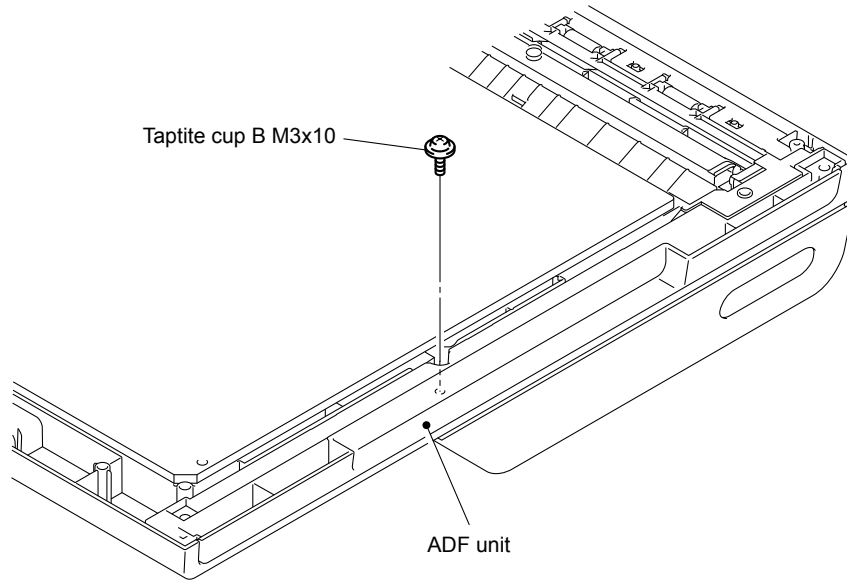

Fig. 3-113

- (5) Turn the ADF unit right side up.
- (6) Remove the five Taptite cup B M3x10 screws from the Upper ADF chute.
- (7) Remove the Upper ADF chute from the ADF unit.

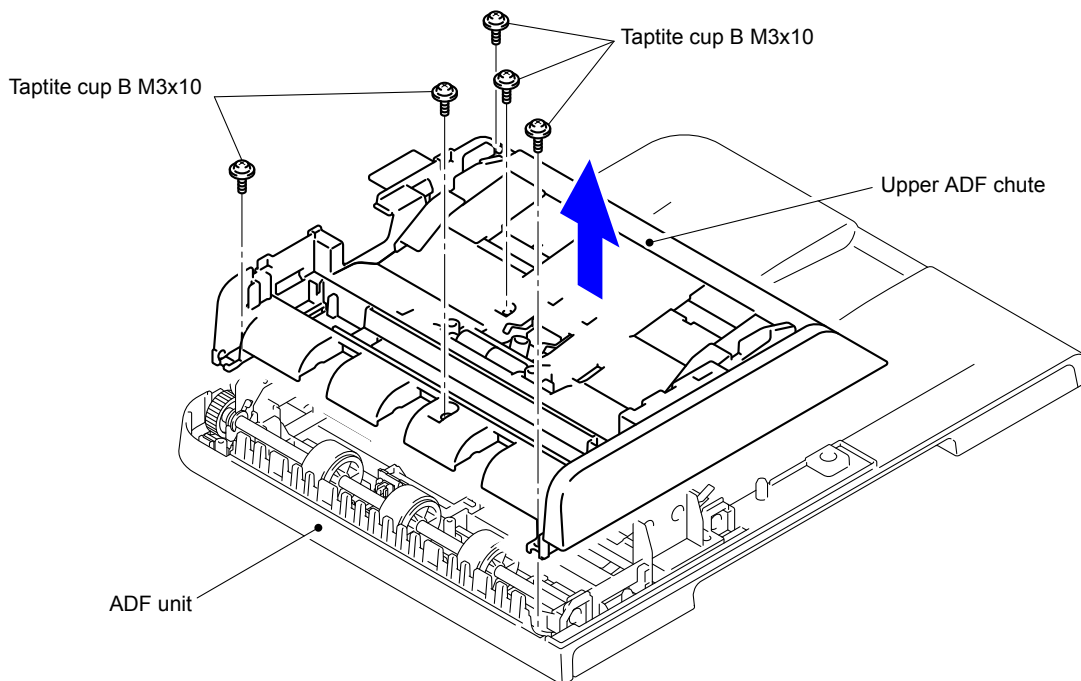

Fig. 3-114

Assembling Note:

When you replace this part without disassembling the Second side CIS unit, follow the instructions given below:

- Shift the Upper ADF chute to the position shown in the figure so that it will not interfere with the work.
- Be careful not to damage the Flat cable.

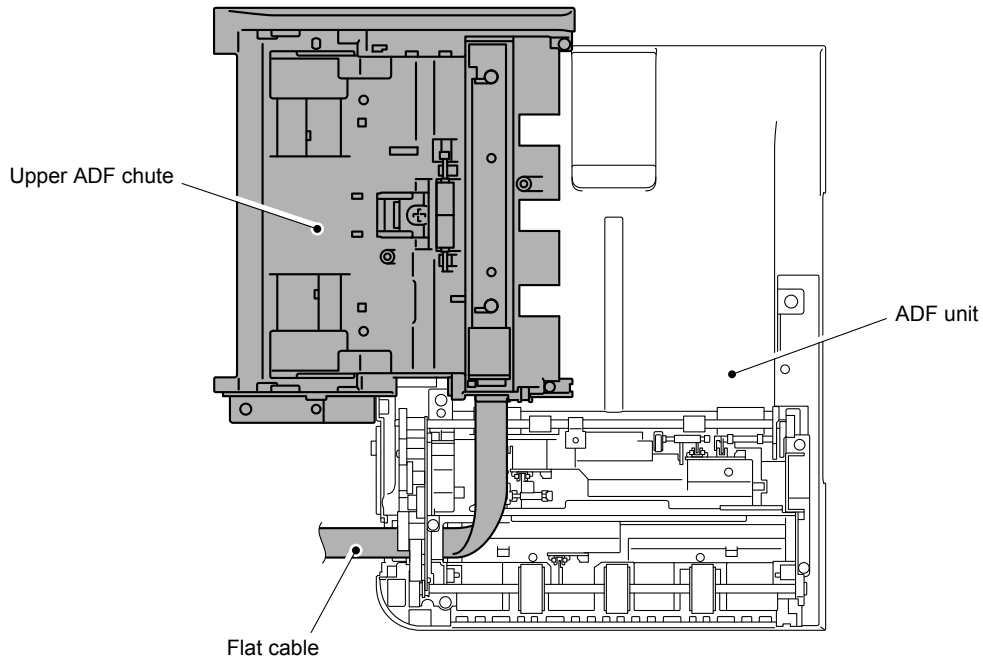

Fig. 3-115

- (8) Lift the film. (Only when the Film is inserted)
- (9) Push and open the Rib and remove the ADF cover/document detection sensor PCB ASSY from the Lower ADF chute.

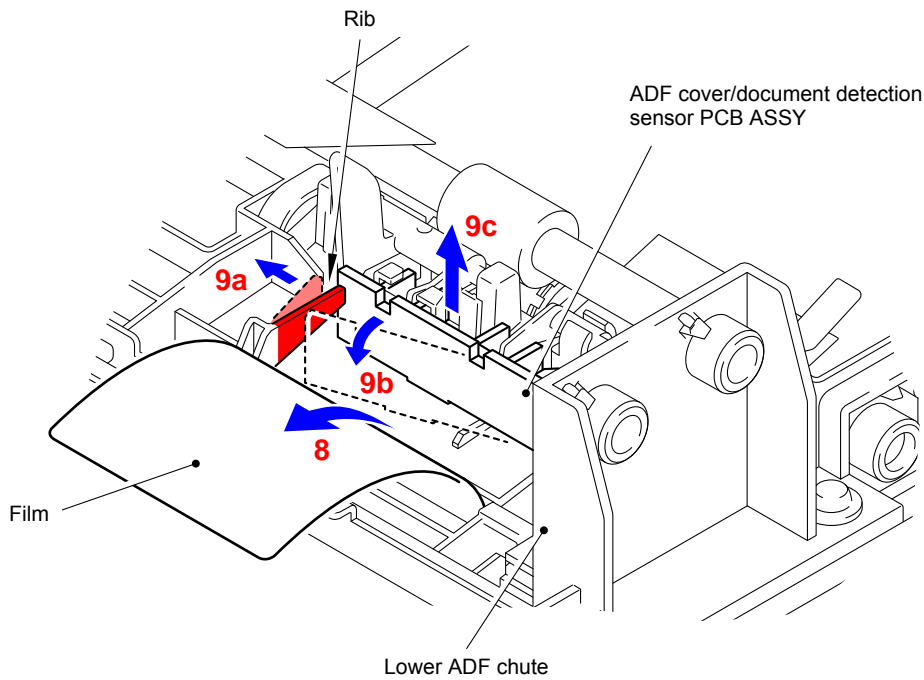

Fig. 3-116

(10) Disconnect the Connector from the ADF cover/document detection sensor PCB ASSY.

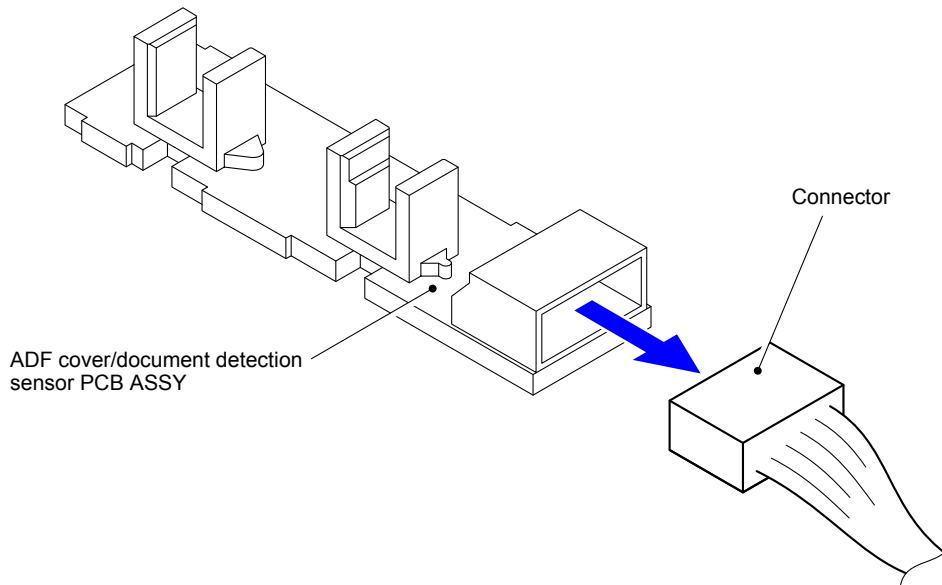

Fig. 3-117

(11) Lift the film. (Only when the Film is inserted)

(12) Push and open the Rib and remove the Second side document scanning position sensor PCB ASSY from the Lower ADF chute.

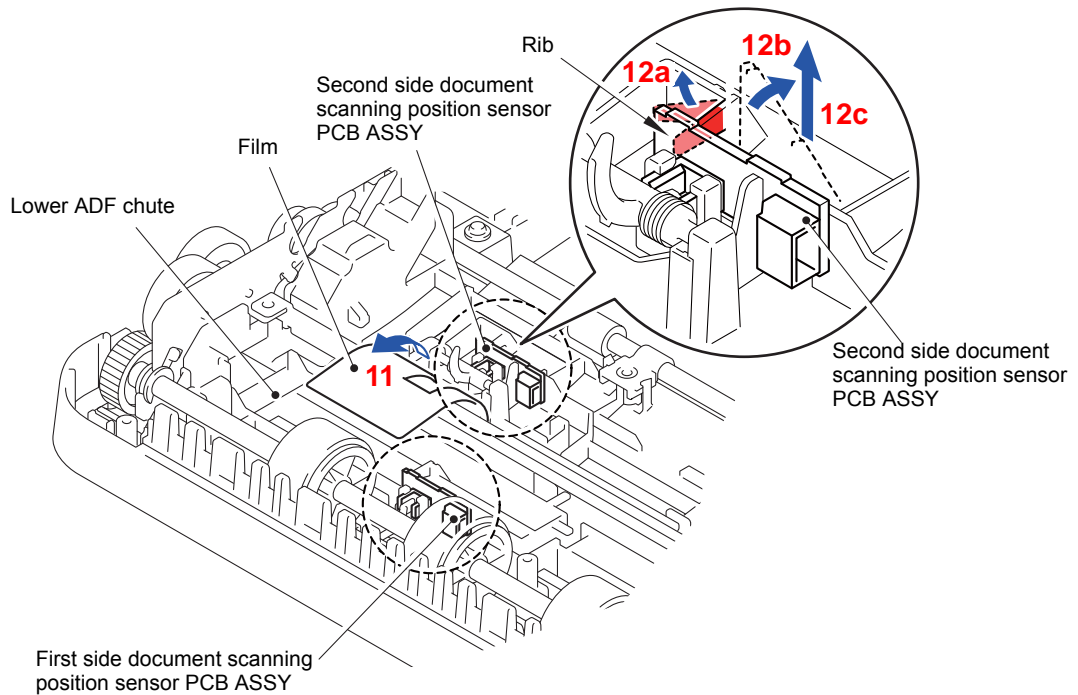

Fig. 3-118

(13) Disconnect the Connector from the Second side document scanning position sensor PCB ASSY.

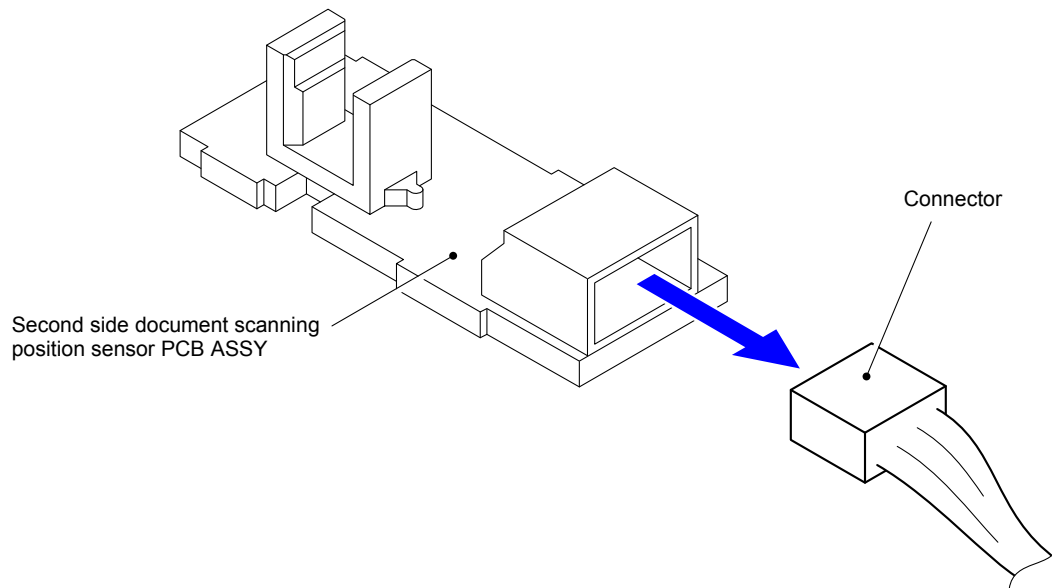

Fig. 3-119

(14) Remove the First side document scanning position sensor PCB ASSY in the same way.

9.29 Document Feed Roller ASSY 2

- (1) Remove the three Taptite cup B M3x10 screws from the Lower ADF chute.
- (2) Release all the wiring from the Document cover.
- (3) Release the Hook and remove the Lower ADF chute from the Document cover.

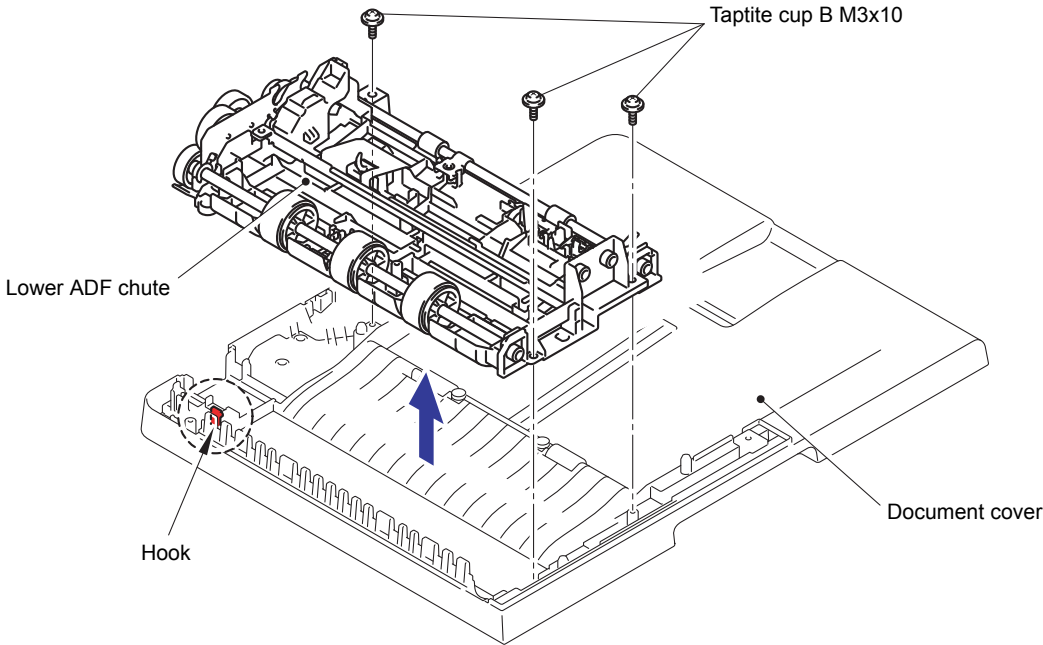

Fig. 3-120

- (4) Release the Pin of the Conductive bushing and rotate it to the position shown in the figure.

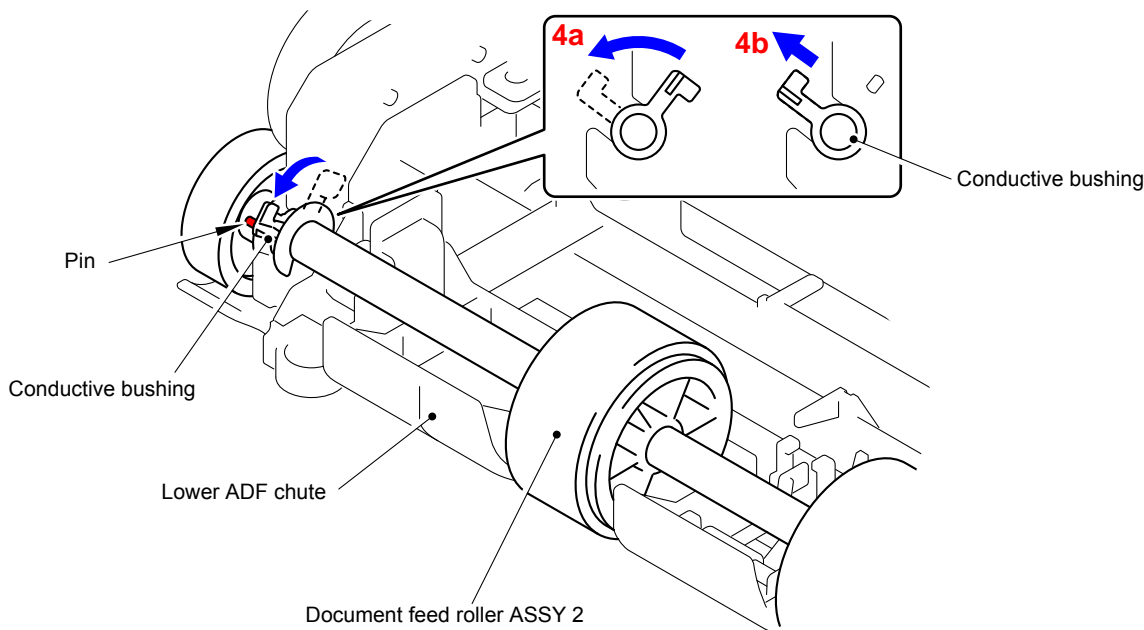

Fig. 3-121

(5) Remove the Document feed roller ASSY 2 from the Lower ADF chute.

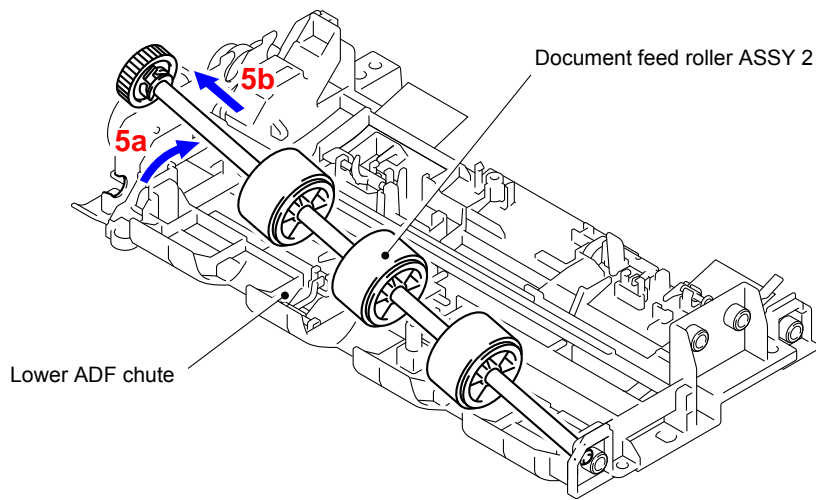

Fig. 3-122

9.30 Eject Film

- (1) Release the two Hooks and remove the Document ejection roller bushing from the Document ejection roller.

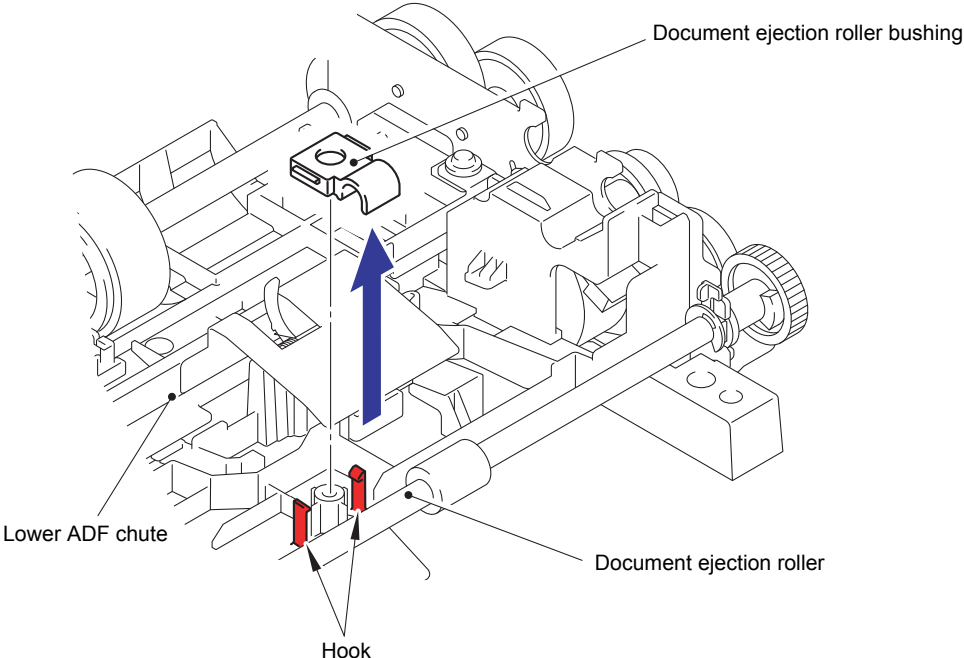

Fig. 3-123

- (2) Rotate the Conductive bushing to release the lock.

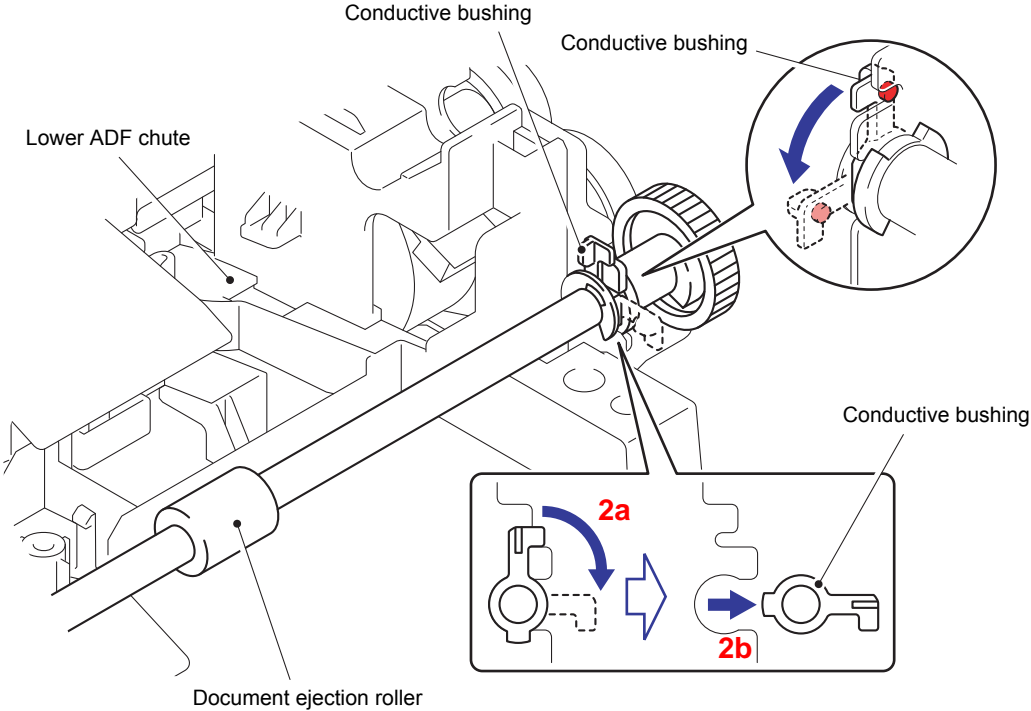

Fig. 3-124

(3) Remove the Document ejection roller from the Lower ADF chute.

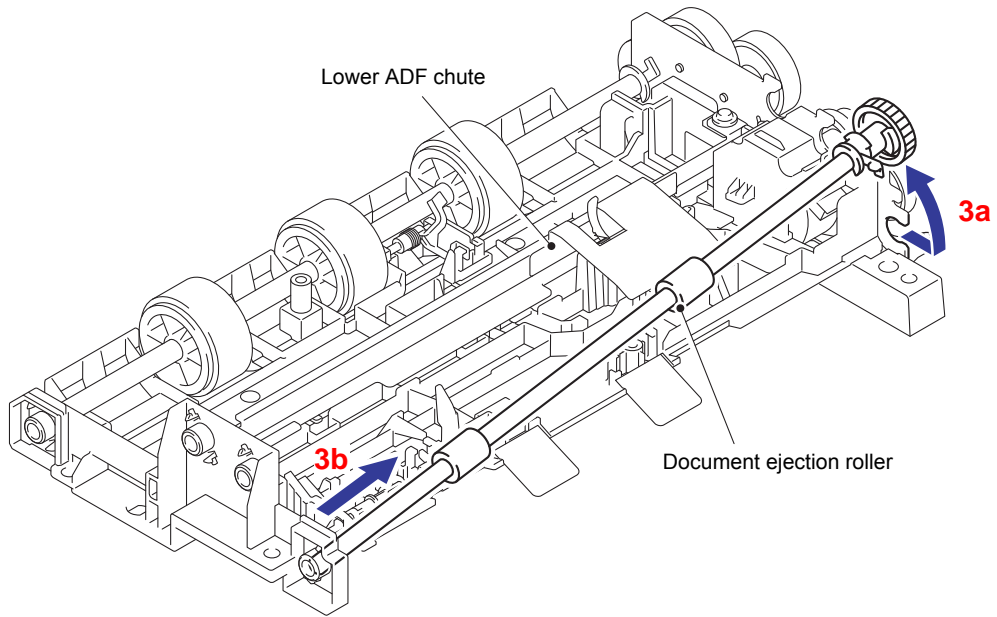

Fig. 3-125

(4) Peel off the double-sided adhesive tape and remove the Eject film from the Lower ADF chute.

■ A4 model

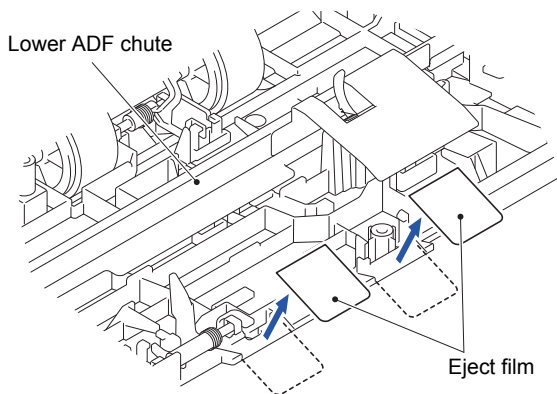

Fig. 3-126

■ Legal model

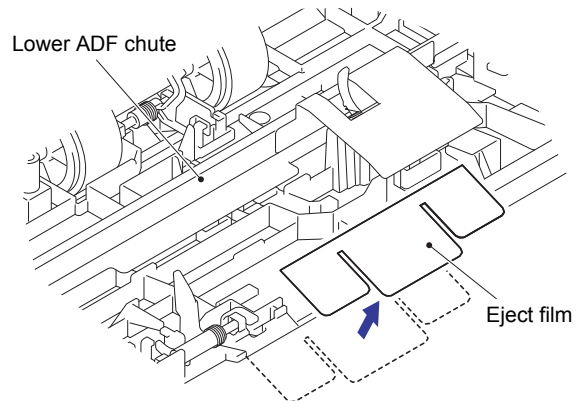

Fig. 3-127

9.31 ADF Motor

- (1) Remove the Taptite cup S M3x8 SR screw and remove the ADF FG harness.

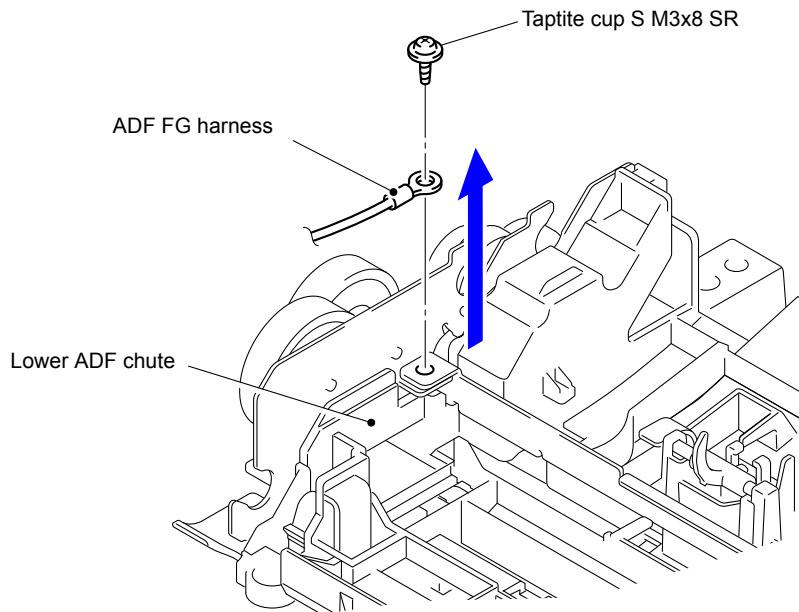

Fig. 3-128

- (2) Remove the three Taptite cup B M3x10 screws and remove the Drive frame ASSY from the Lower ADF chute.

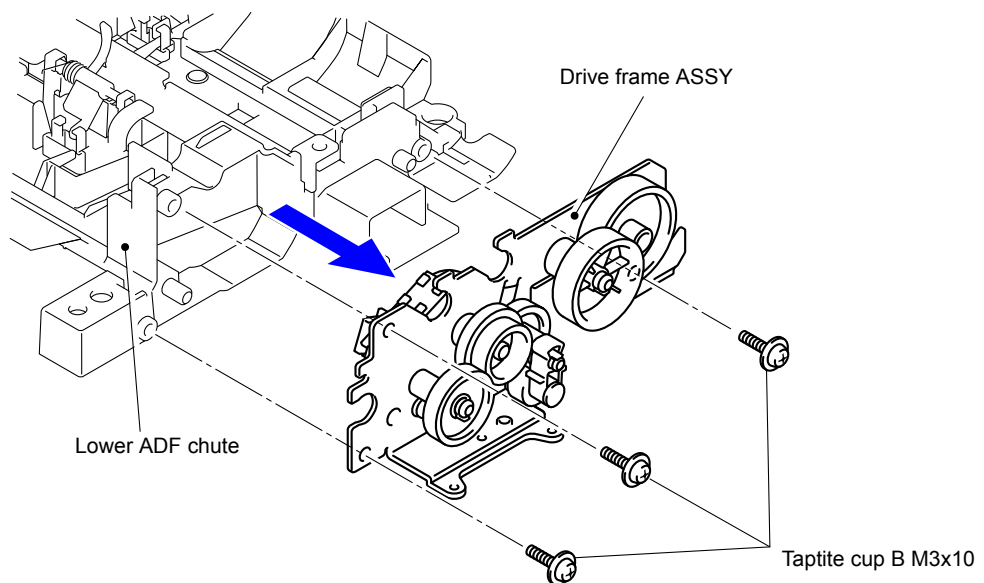

Fig. 3-129

Assembling Note:

When assembling the Drive frame ASSY, ensure that the Arm ASSY L2 are placed in the positions as shown in the figure below.

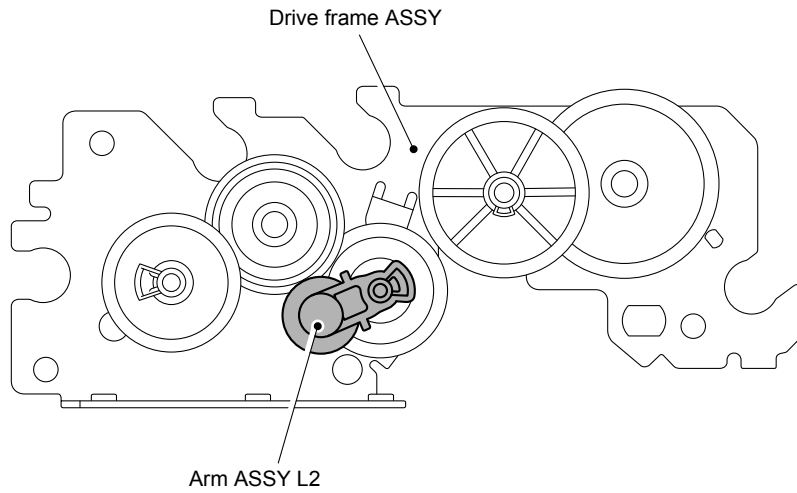

Fig. 3-130

(3) Disconnect the Connector from the ADF motor.

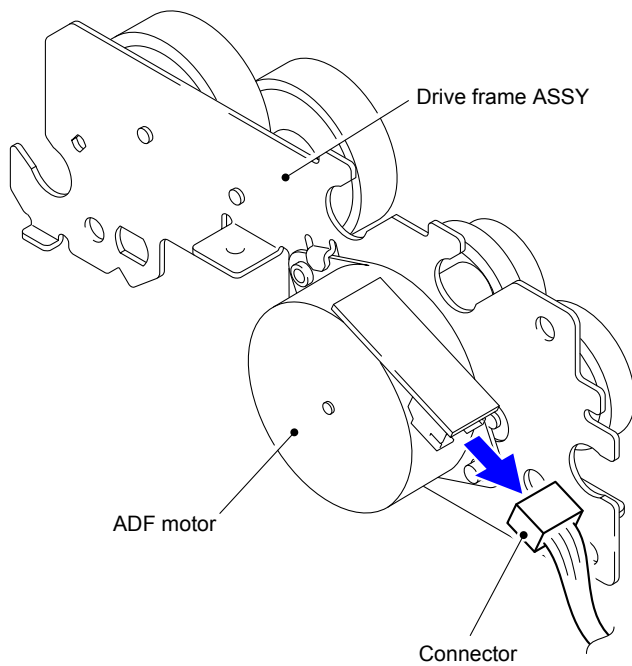

Fig. 3-131

- (4) Release the Hook and remove the Gear43 from the Drive frame ASSY.

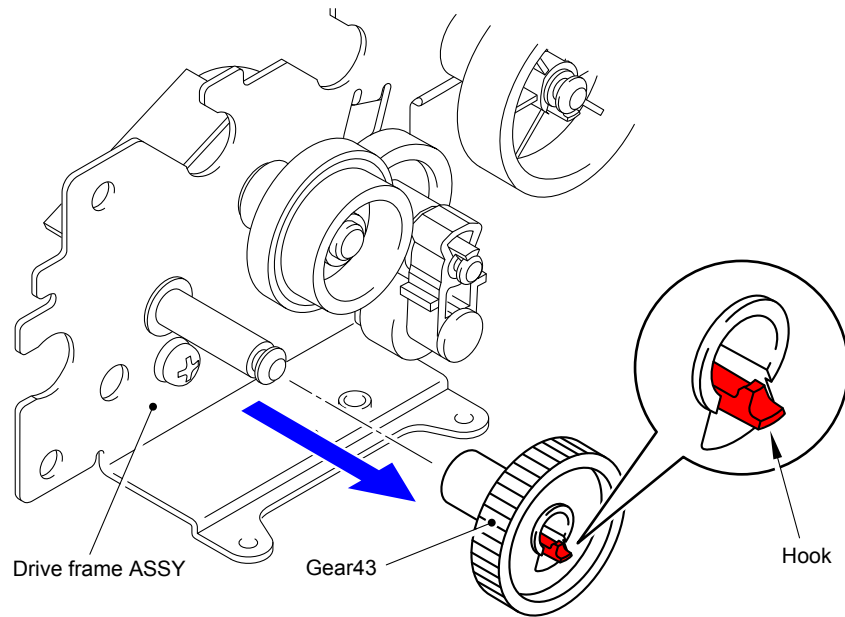

Fig. 3-132

- (5) Remove the Screw pan (S/P washer) M3x6 screw and remove the ADF motor from the Drive frame ASSY.

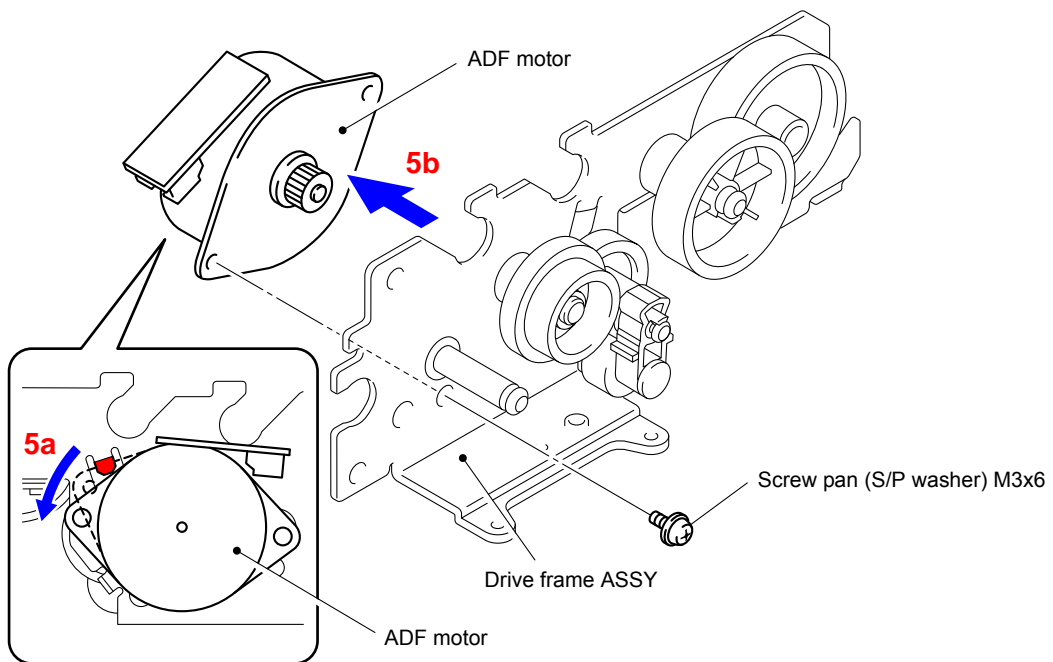

Fig. 3-133

9.32 Document Cover ASSY

- (1) Remove the three Document feed pinch roller spring shafts and three Document feed pinch rollers from the Document cover ASSY.

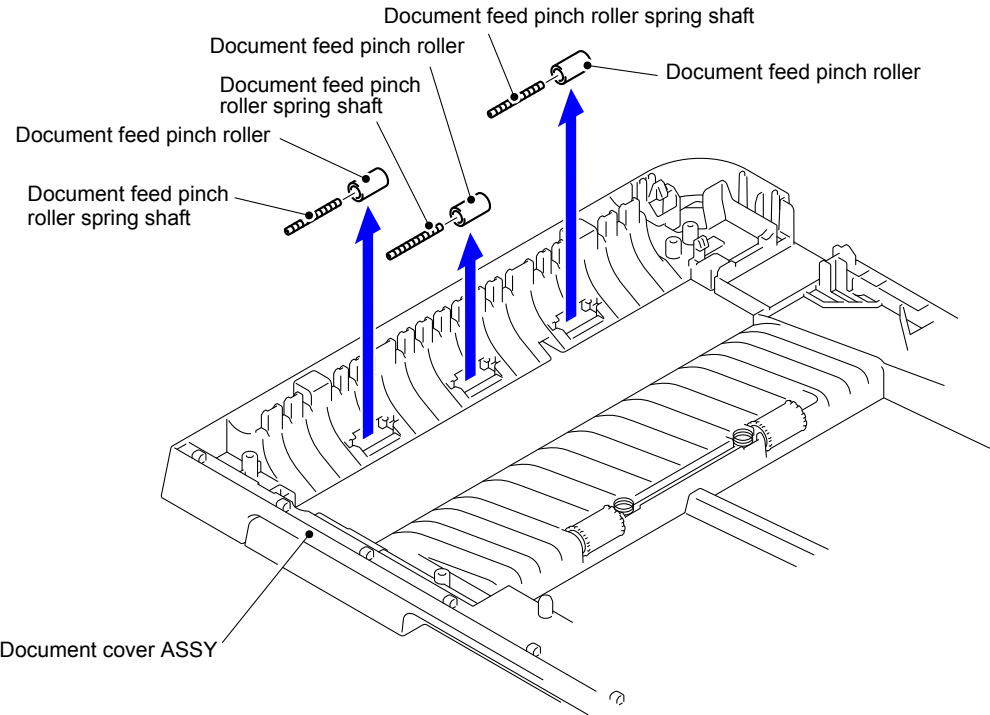

Fig. 3-134

9.33 Control Panel ASSY/Document Scanner Unit

■ A4 model

- (1) Remove the four Taptite cup B M3x10 screws from the Control panel ASSY.

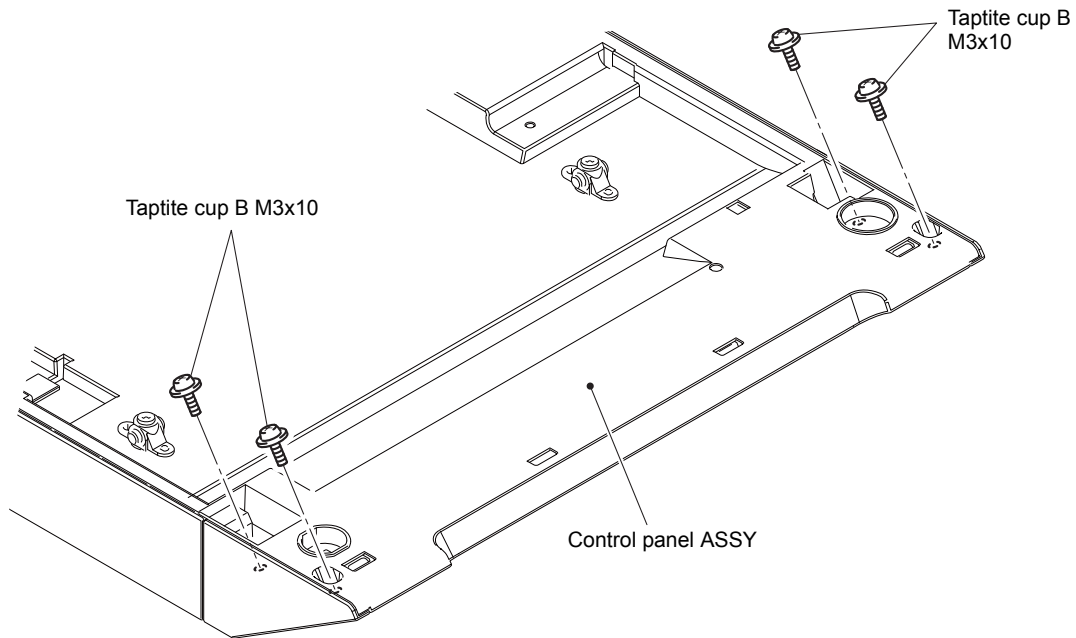

Fig. 3-135

- (2) Release the four Hooks 1. Move the Control panel ASSY in the direction of the arrow and release the other four Hooks.
- (3) Remove the Control panel ASSY from the Document scanner unit.
- (4) Disconnect the two Connectors (CN5 and CN7) from the Panel PCB unit.

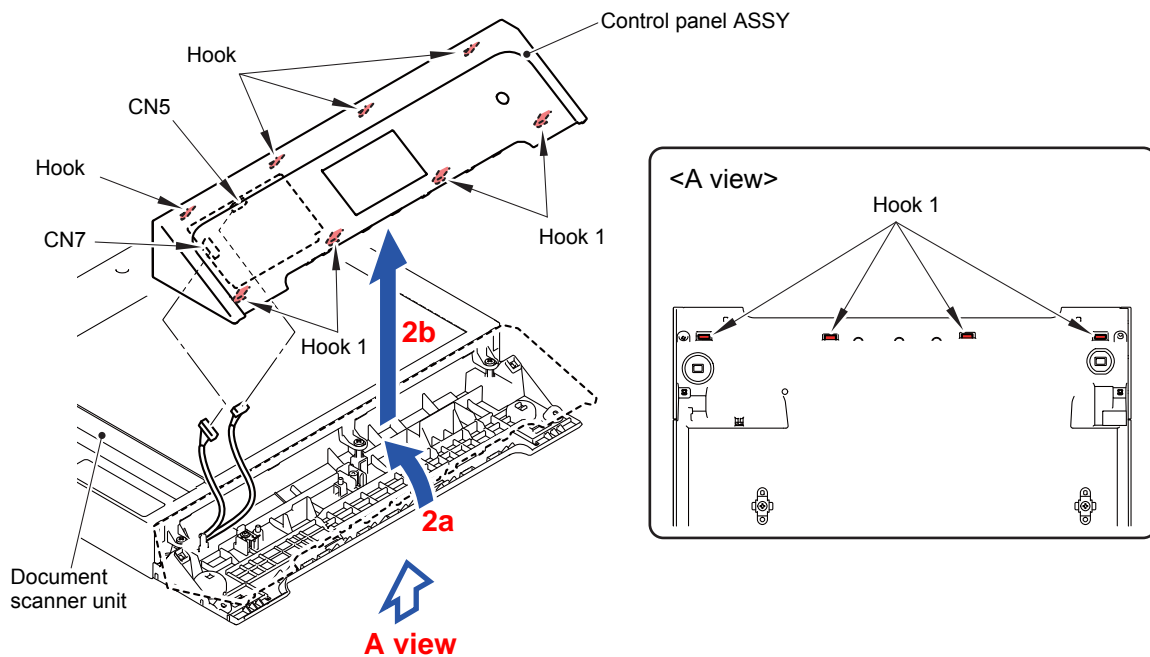

Fig. 3-136

■ **Legal model**

- (1) Remove the two Taptite bind B M4x12 screws from the Control panel ASSY.
- (2) Release the two Hooks at both sides of the Control panel ASSY.

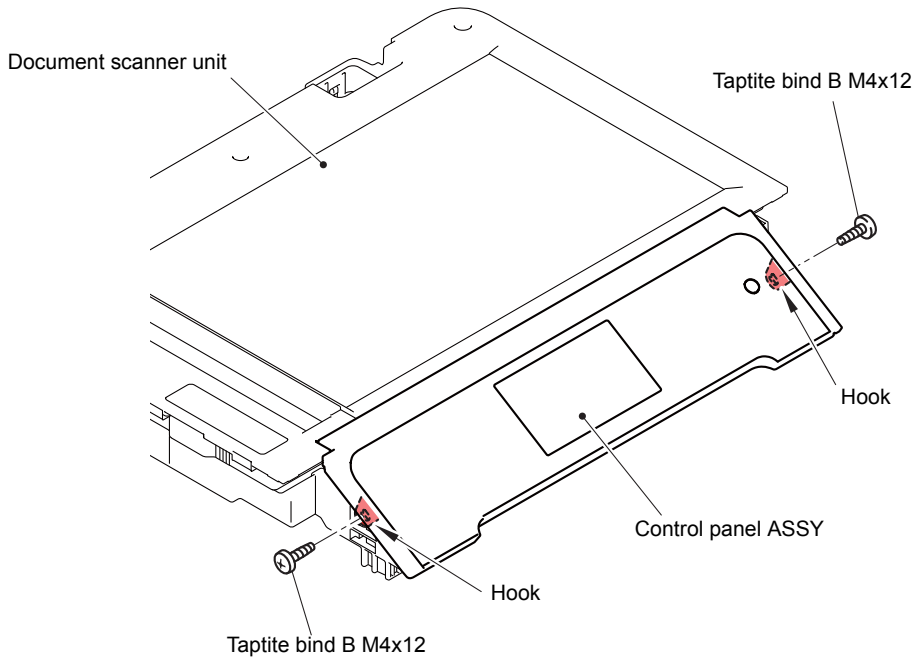

Fig. 3-137

- (3) Release the other eight Hooks and remove the Control panel ASSY from the Document scanner unit.
- (4) Disconnect the two Connectors (CN5 and CN7) from the Control panel ASSY.

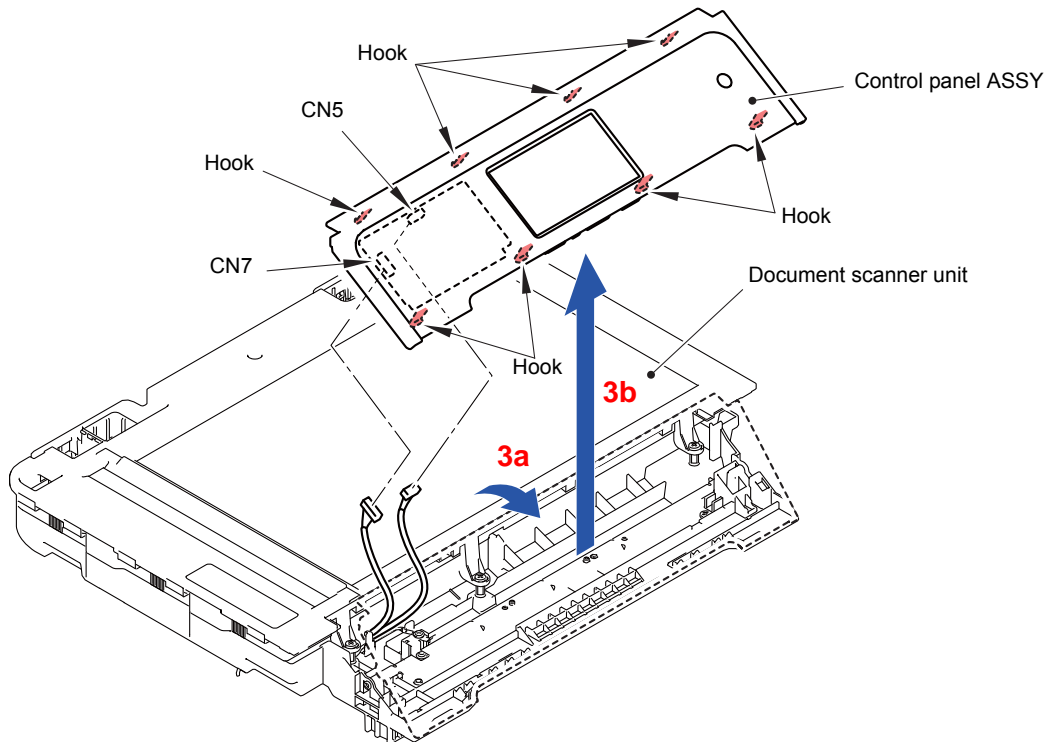

Fig. 3-138

9.34 Panel PCB Unit

- (1) Disconnect the Flat cable (CN4) of the Panel PCB unit and release the wiring.

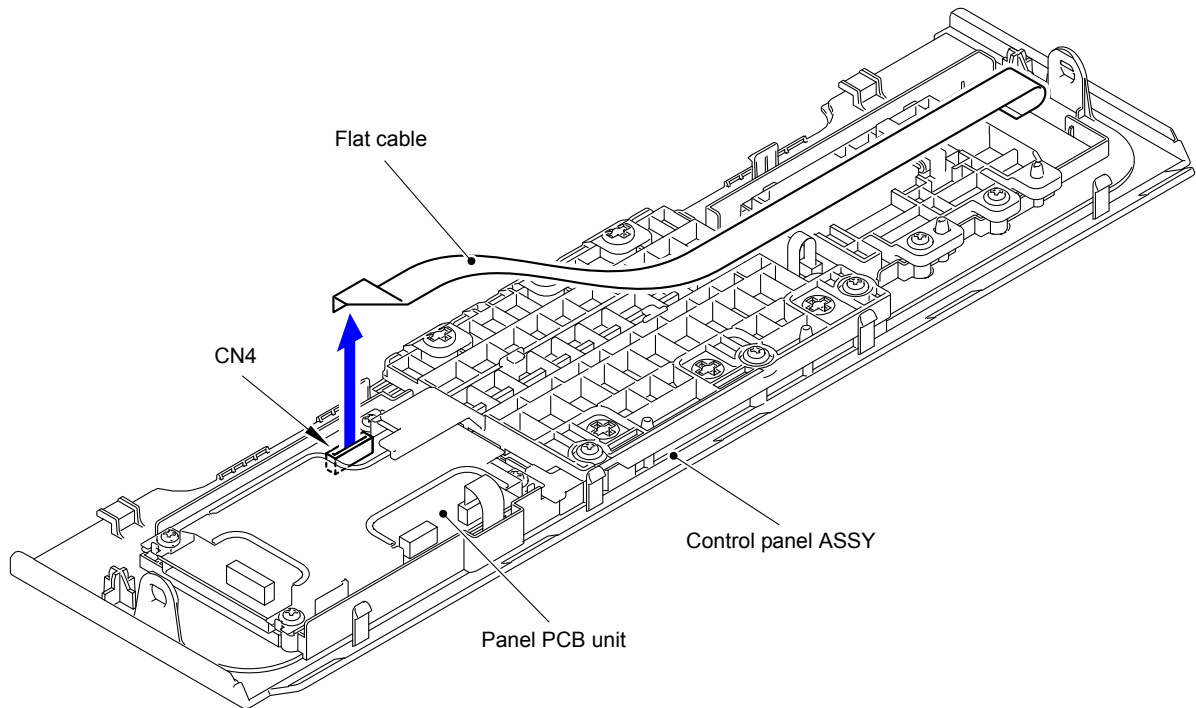

Fig. 3-139

■ A4 model

- (2) Remove the three Taptite cup B M3x10 screws from the LCD hold plate.
- (3) Release the four Hooks and remove the LCD hold plate from the Control panel ASSY.

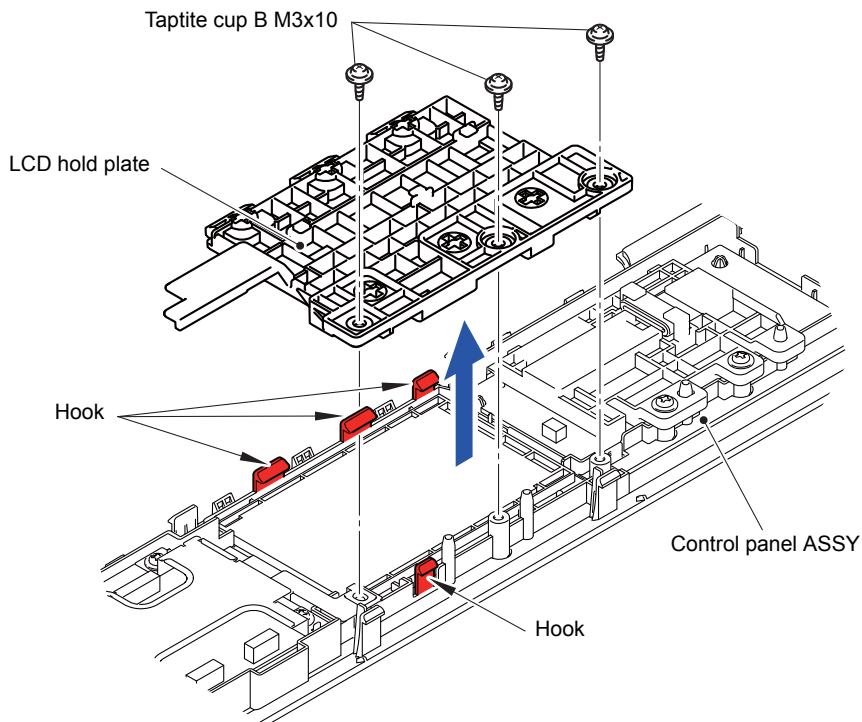

Fig. 3-140

■ **Legal model**

- (2) Remove the three Taptite cup B M3x10 screws from the LCD hold plate.
- (3) Release the six Hooks and remove the LCD hold plate from the Control panel ASSY.

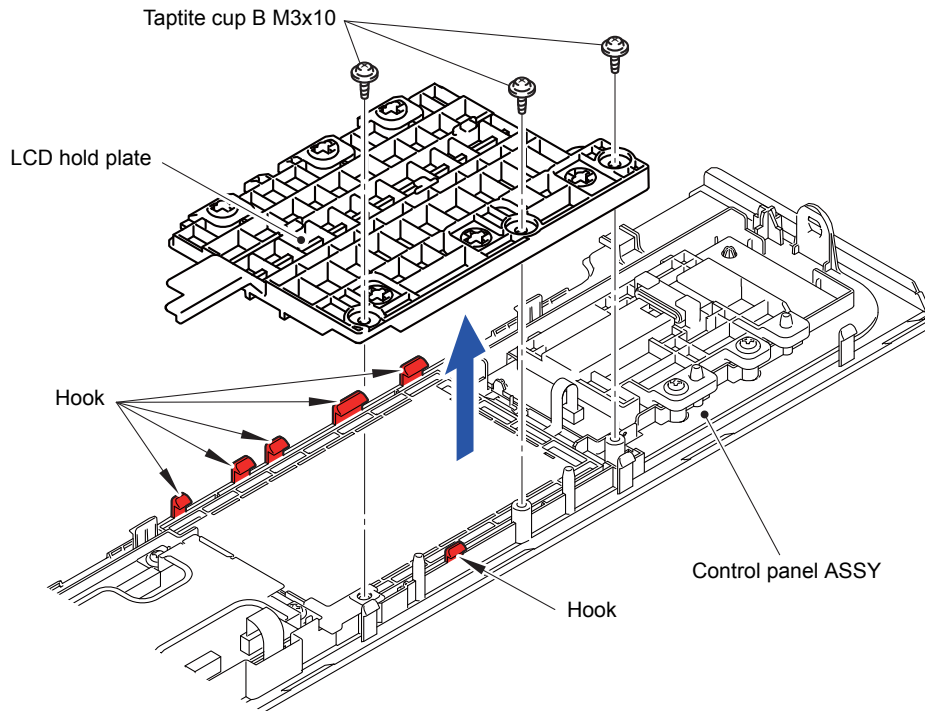

Fig. 3-141

■ **A4 model/Legal model**

Assembling Note:

When assembling the LCD hold plate to the Control panel ASSY, be sure to assemble it in a way that LCD hold tab fits in the groove of the LCD.

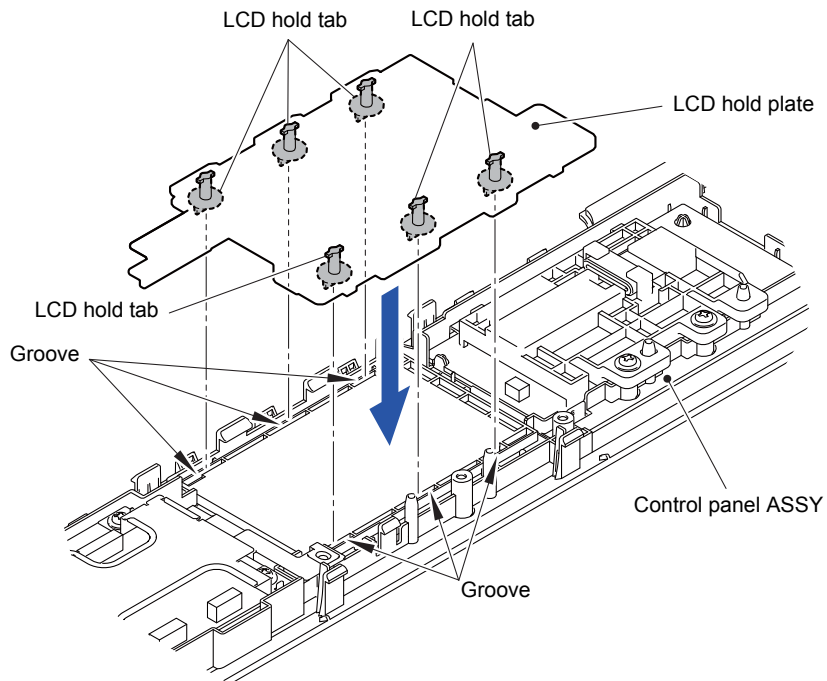

Fig. 3-142

- (4) Remove the four Taptite cup B M3x10 screws and remove the Panel control PCB shield plate cover from the Control panel ASSY.

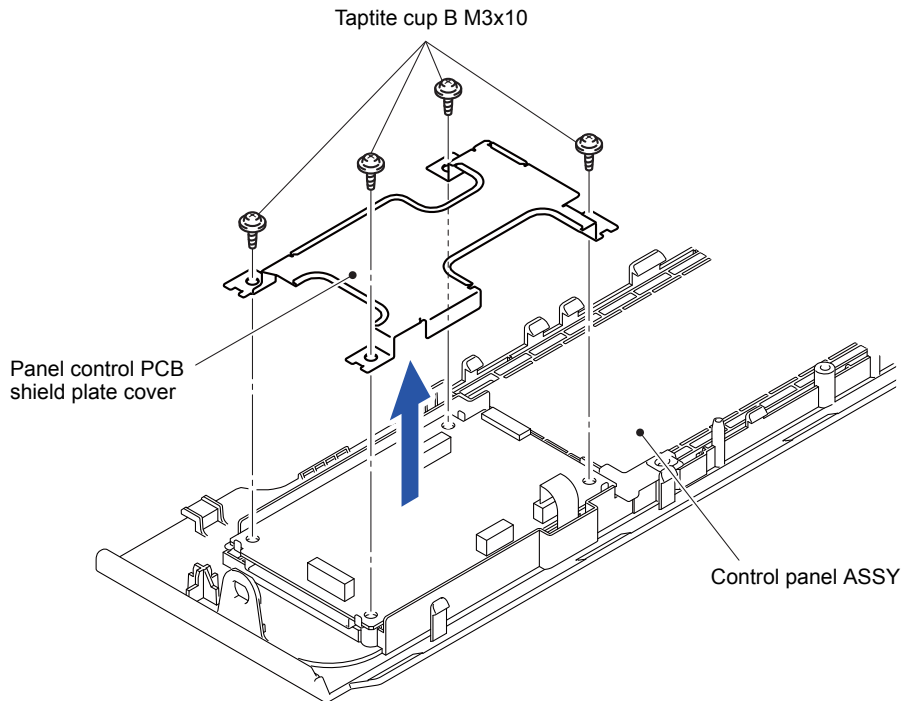

Fig. 3-143

- (5) Release the Lock and disconnect the Flat cable (CN1) of the Panel PCB unit.
- (6) Disconnect the Flat cable (CN2) from the Panel PCB unit. (Model with NFC only)
- (7) Remove the Panel PCB unit from the Control panel ASSY.

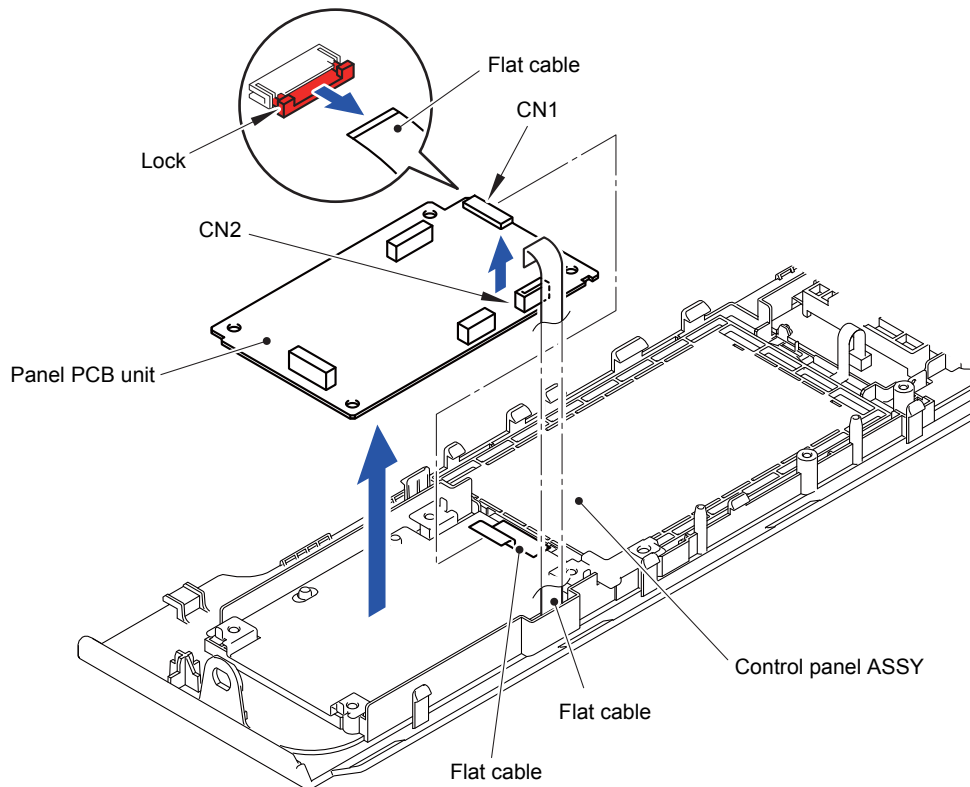

Fig. 3-144

9.35 LCD

(1) Remove the LCD from the Control panel ASSY.

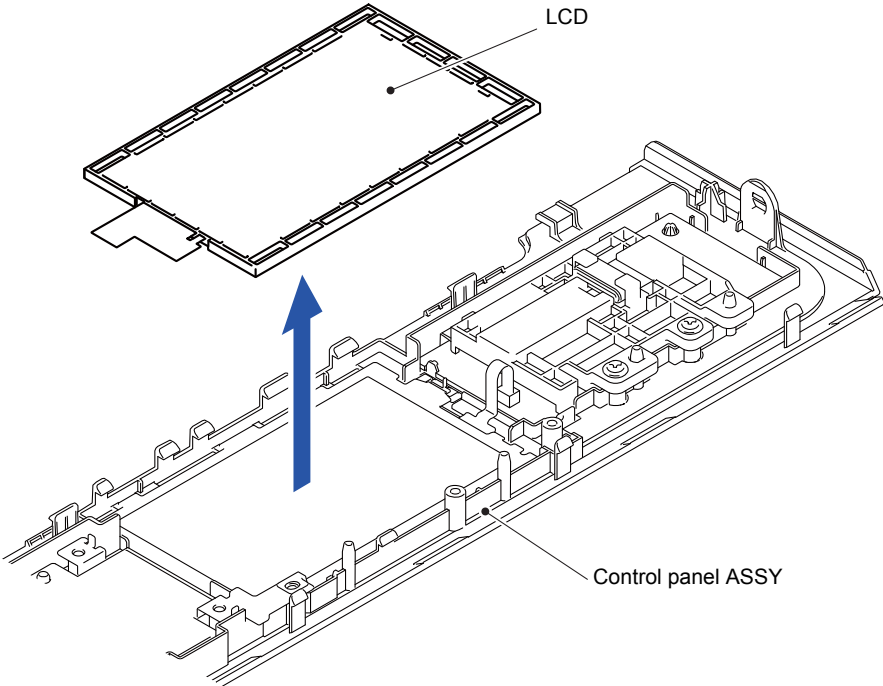

Fig. 3-145

9.36 Touch Panel ASSY

- (1) Disconnect the Flat cable (CN1) of the Touch panel ASSY.
- (2) Remove the Touch panel ASSY from the Key PCB ASSY.

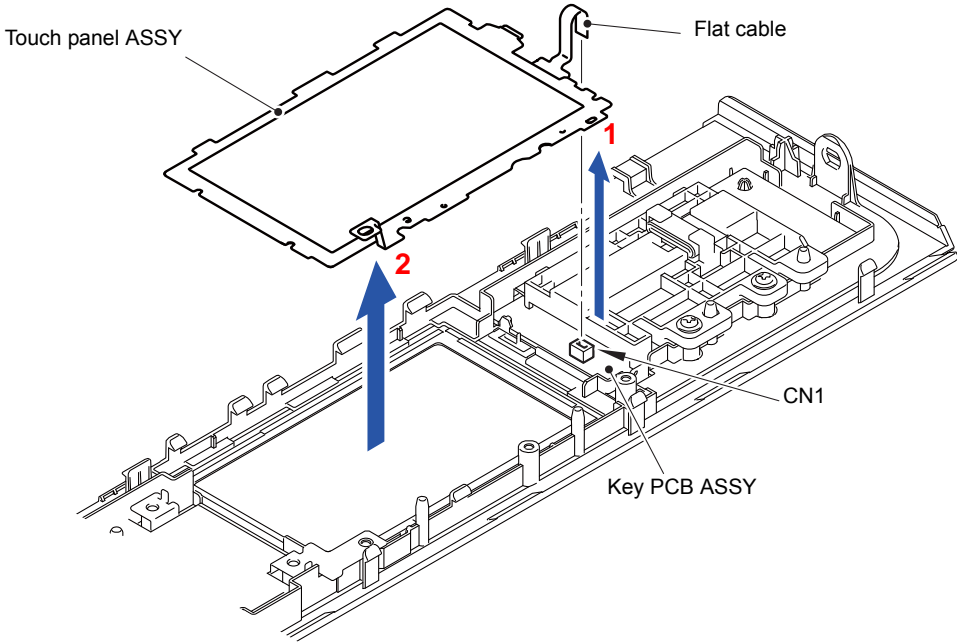

Fig. 3-146

Assembling Note:
When assembling the Touch panel ASSY, be sure to assemble “A” of the Touch panel ASSY as shown in the figure below.

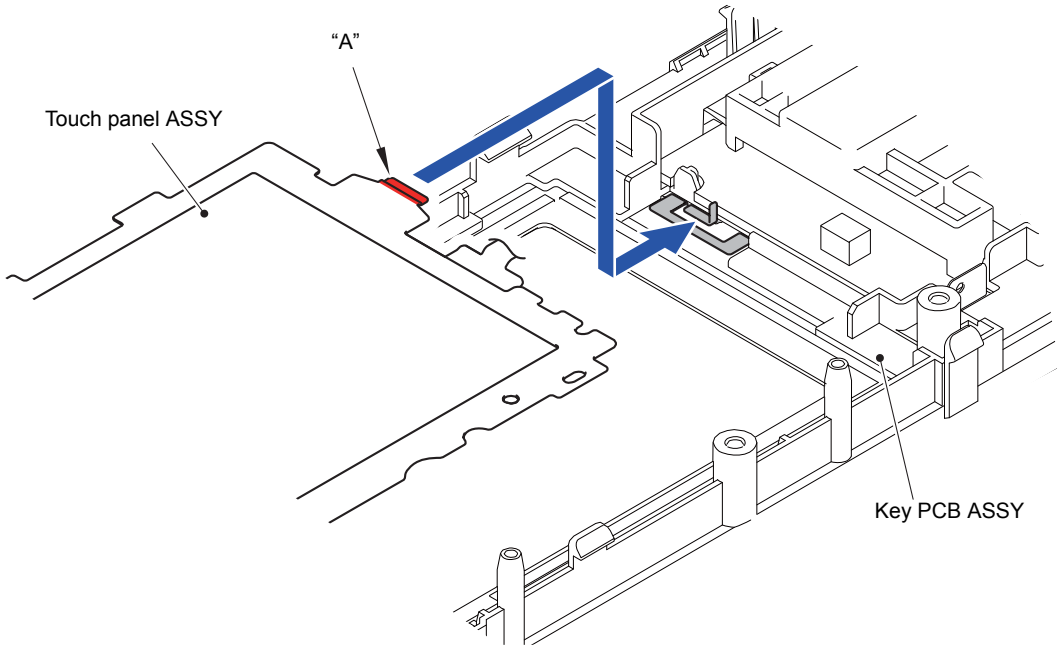

Fig. 3-147

9.37 NFC PCB ASSY (Model with NFC only)/Panel Cover ASSY

- (1) Remove the PCB insulation sheet from the Shield plate base.
- (2) Remove the Shield plate base from the Panel cover ASSY.

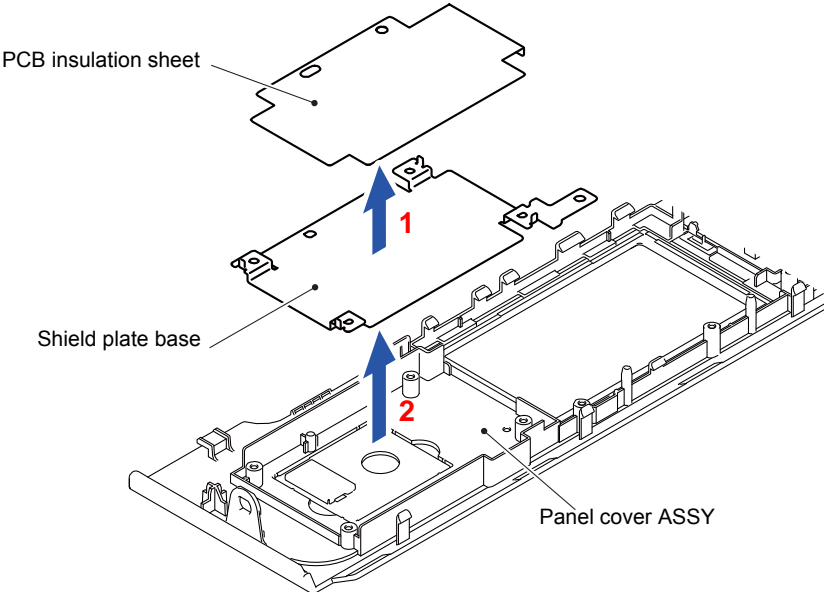

Fig. 3-148

- (3) Remove the NFC PCB ASSY from the Panel cover ASSY.

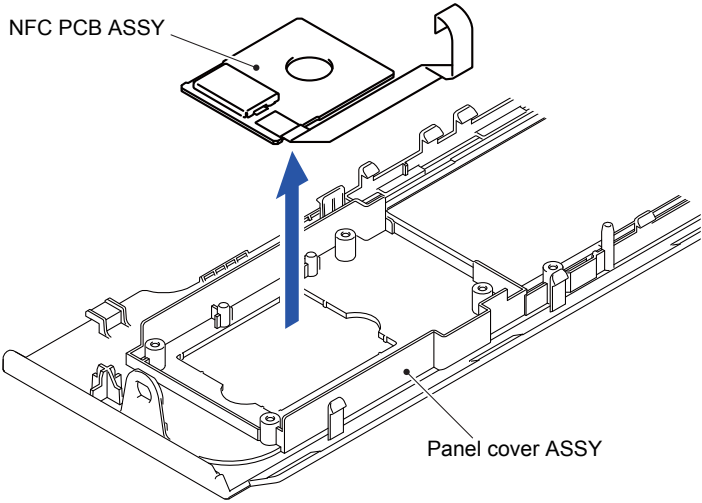

Fig. 3-149

Assembling Note:
 When the NFC PCB ASSY are replaced, be sure to fold and assemble the NFC PCB ASSY flat cable as shown in the figure.

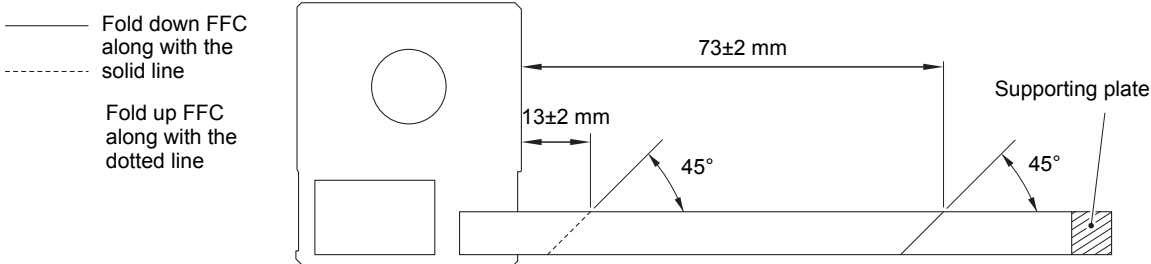

Fig. 3-150

9.38 First Side CIS Unit/First Side CIS Flat Cable

- (1) Remove the six Taptite bind B M4x12 screws to remove the Document scanner top cover ASSY from the Document scanner unit.

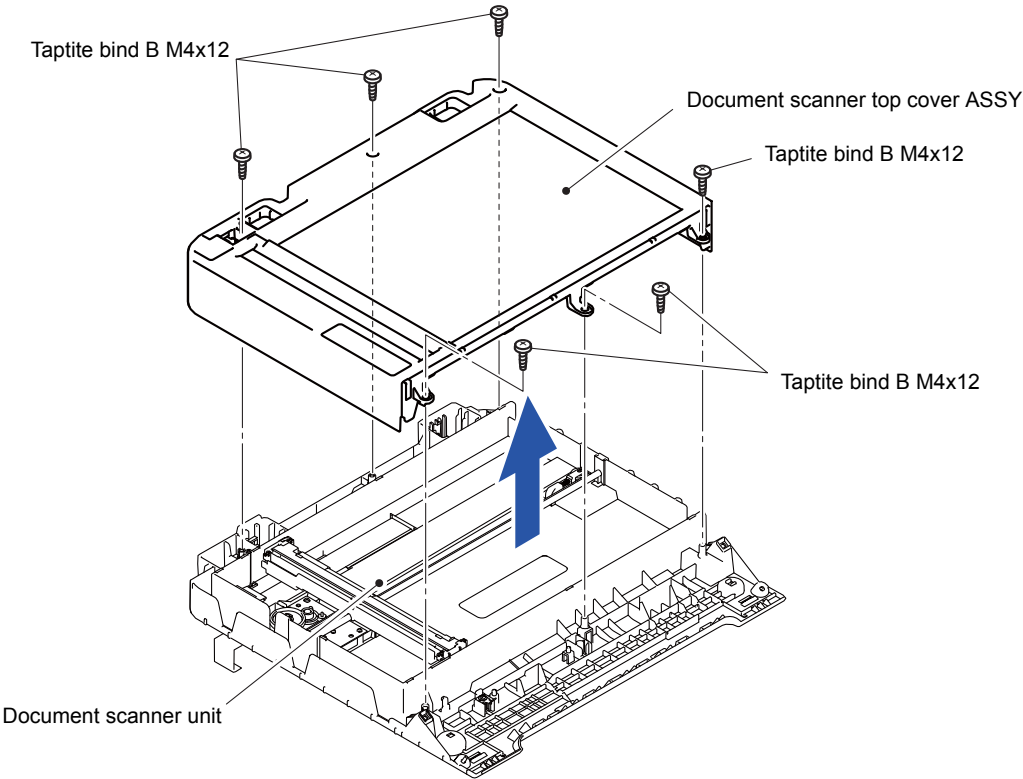

Fig. 3-151

- (2) Remove the CIS guide L and CIS guide R from the First side CIS unit.

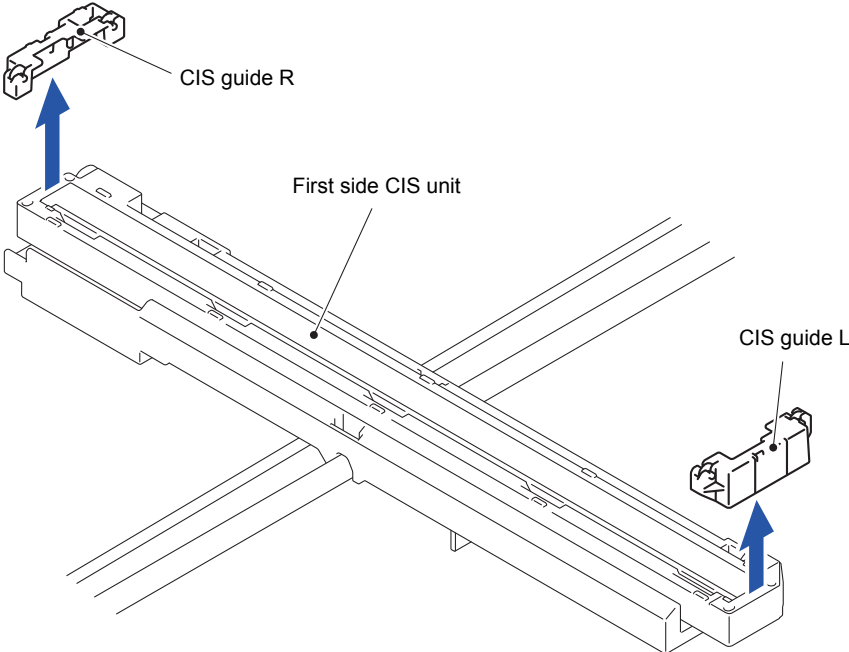

Fig. 3-152

(3) Remove the First side CIS unit from the CIS drive belt.

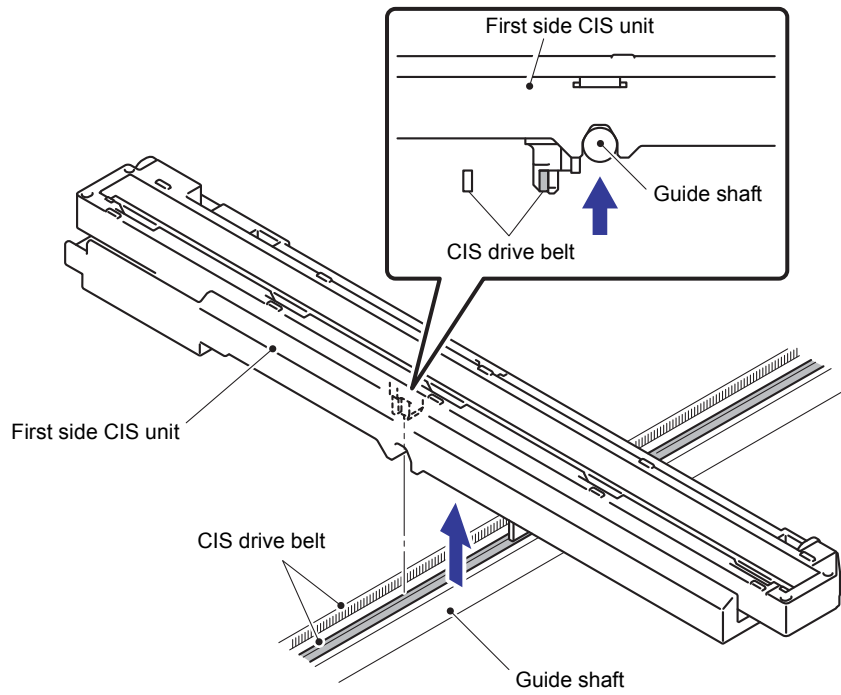

Fig. 3-153

(4) Peel off the Double-sided adhesive tape from the First side CIS flat cable.

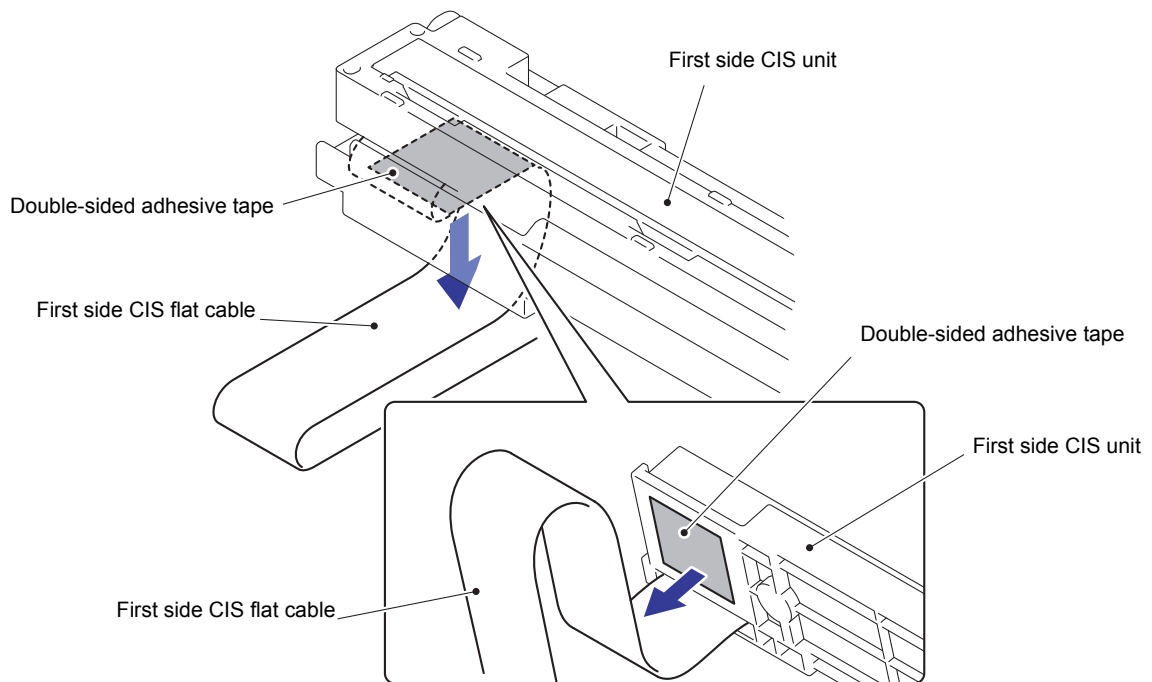

Fig. 3-154

- (5) Open the First side CIS unit. Remove the First side CIS flat cable from the Connector (CN1) of the First side CIS unit.

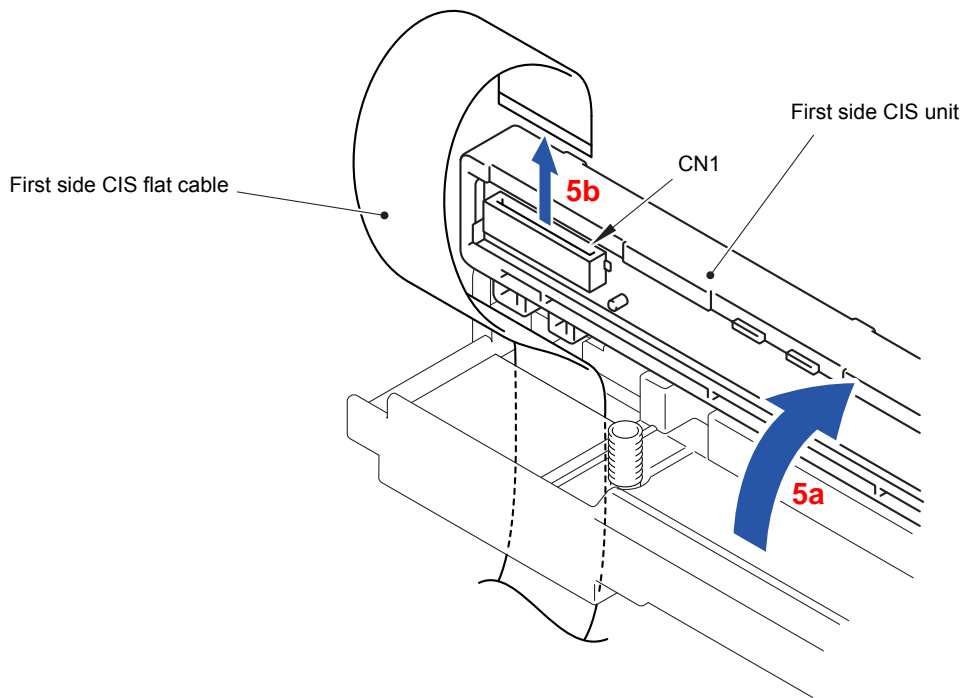

Fig. 3-155

- (6) Remove the two Pins to remove the First side CIS unit from the CIS Carriage.

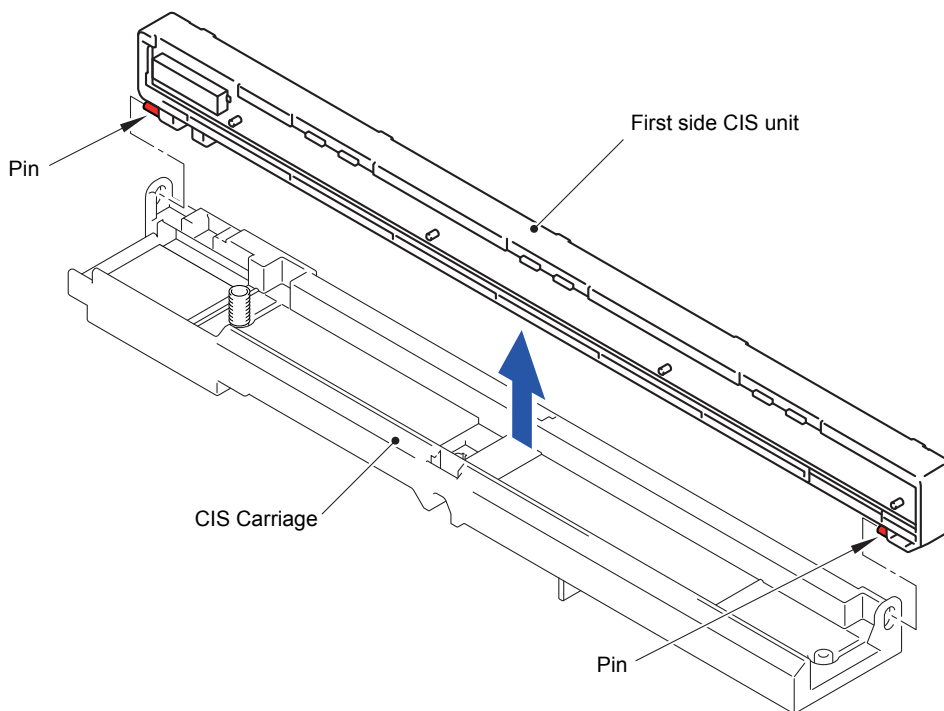

Fig. 3-156

- (7) Peel off the Double-sided adhesive tapes at three locations.

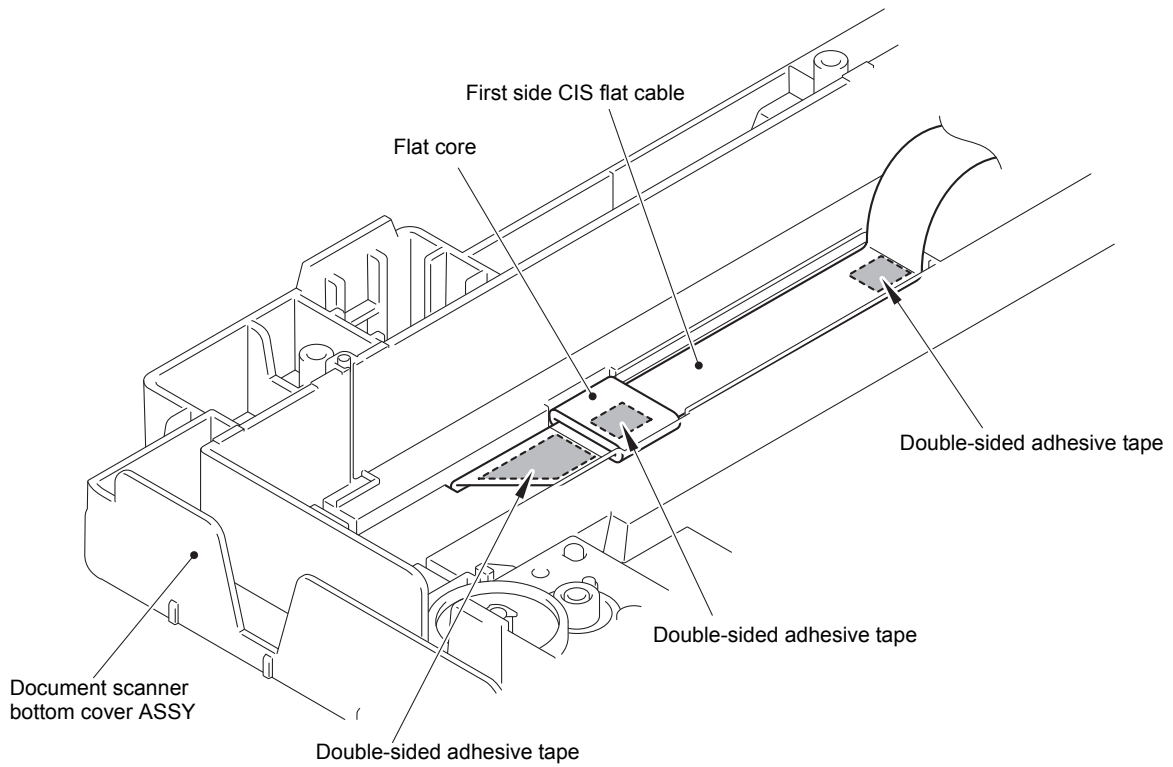

Fig. 3-157

- (8) Pull out the First side CIS flat cable from the Hole of the Document scanner bottom cover ASSY.
(9) Remove the Flat core from the First side CIS flat cable.

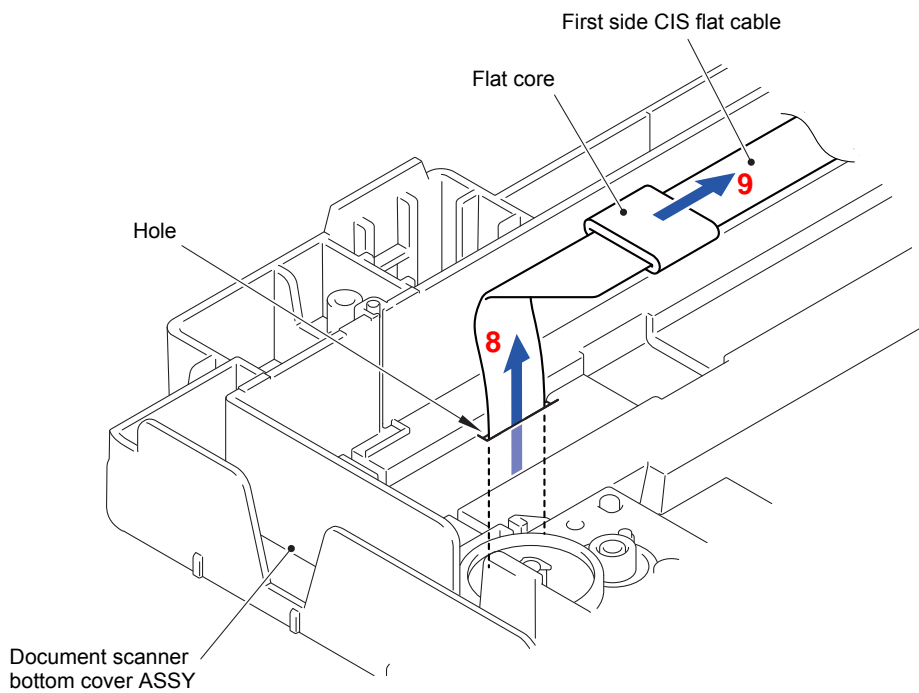

Fig. 3-158

Assembling Note:

When the Document scanner unit are replaced, be sure to fold and assemble the First side CIS flat cable as shown in the figure.

■ **A4 model**

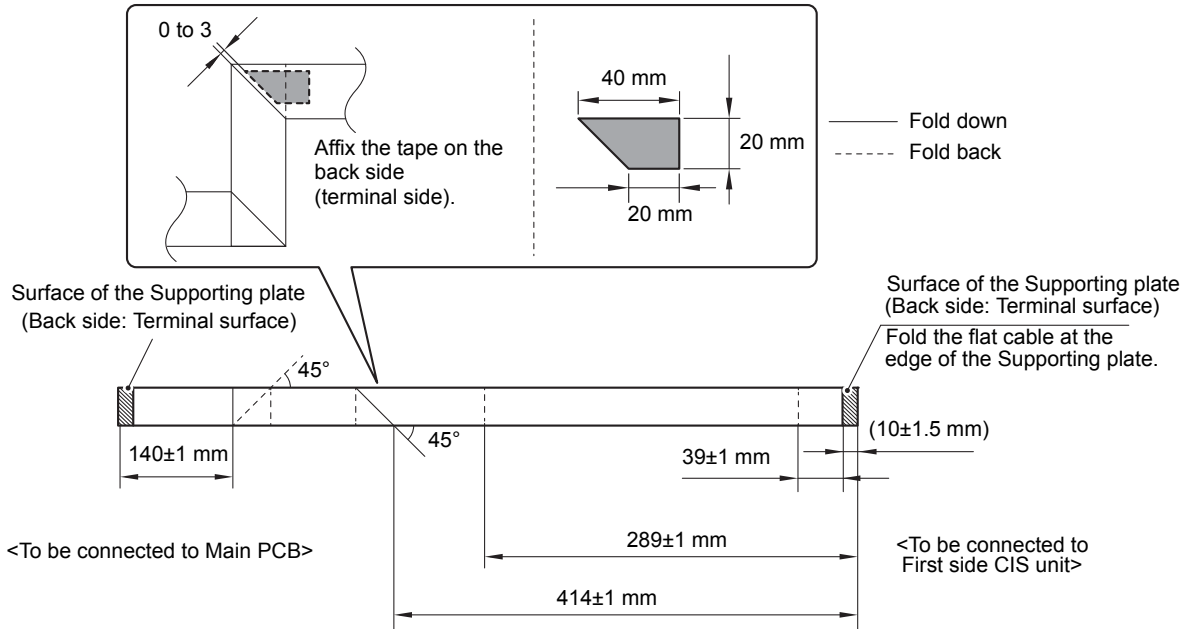

Fig. 3-159

■ **Legal model**

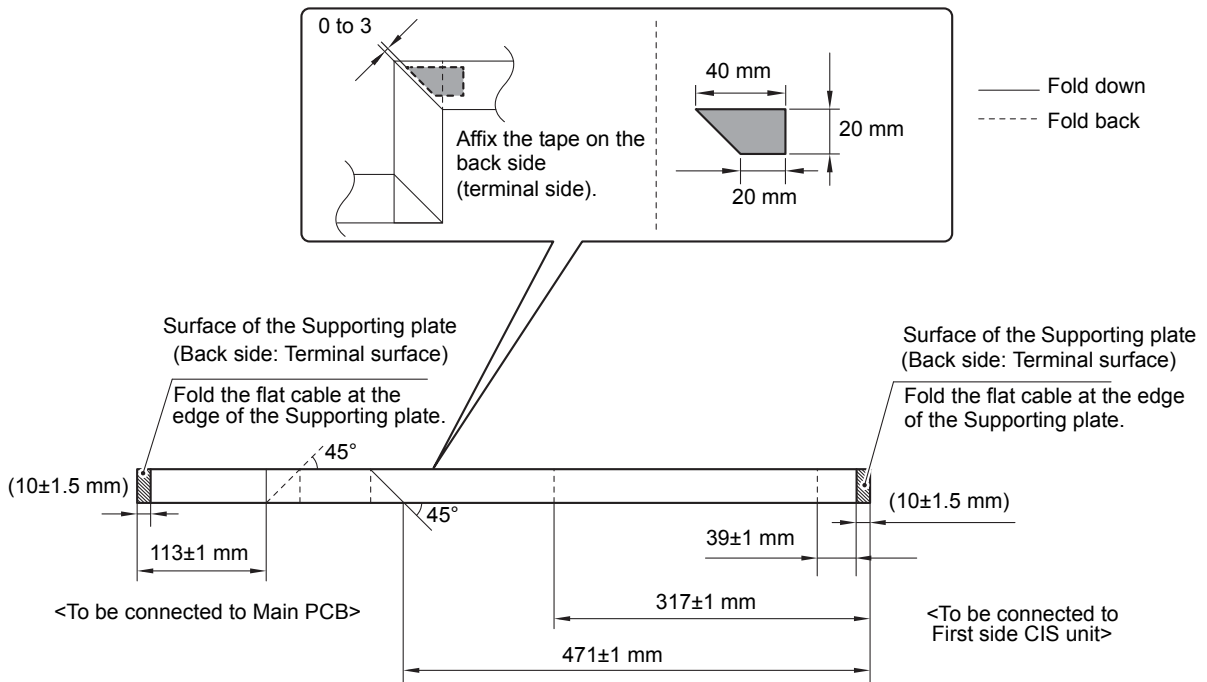

Fig. 3-160

9.39 Joint Film (A4 Model Only)

- (1) Peel off the Double-sided adhesive tape and remove the Joint film from the Joint cover top.

Assembling Note:

When affixing the Joint film, be sure to affix it to the Joint cover top as shown in the figure below.

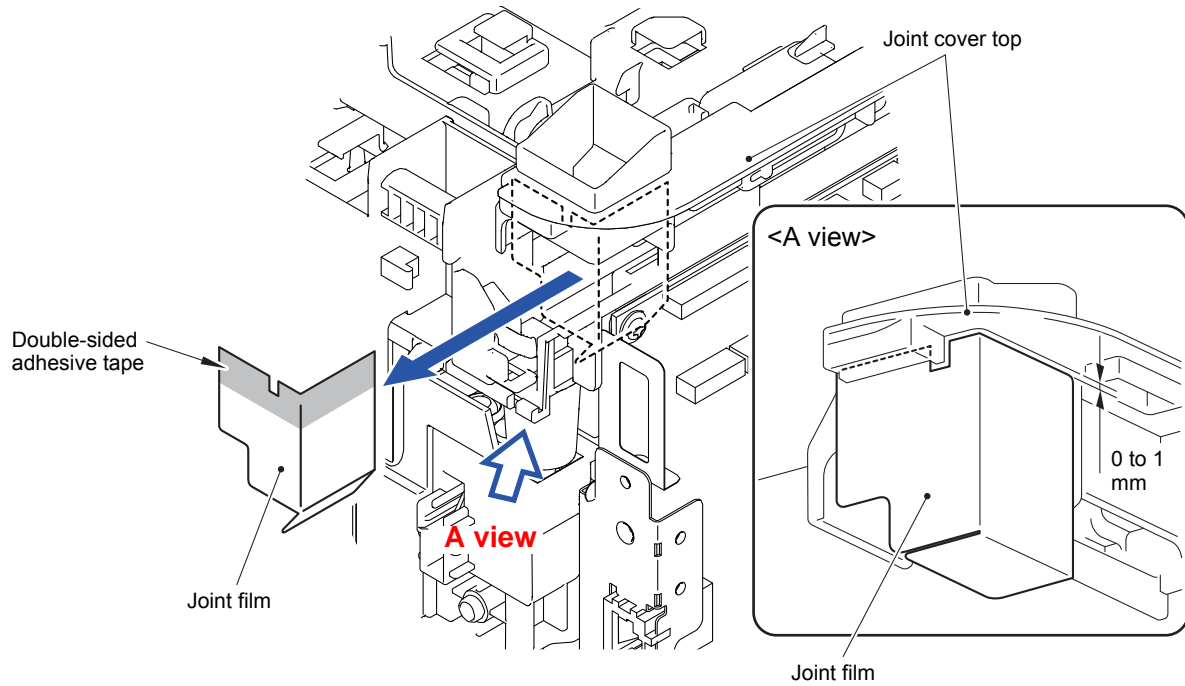

Fig. 3-161

9.40 Joint Film2 (Single-side Scanning Model Only)

(1) Peel off the double-sided adhesive tape and remove the Joint film2 from the Joint cover top.

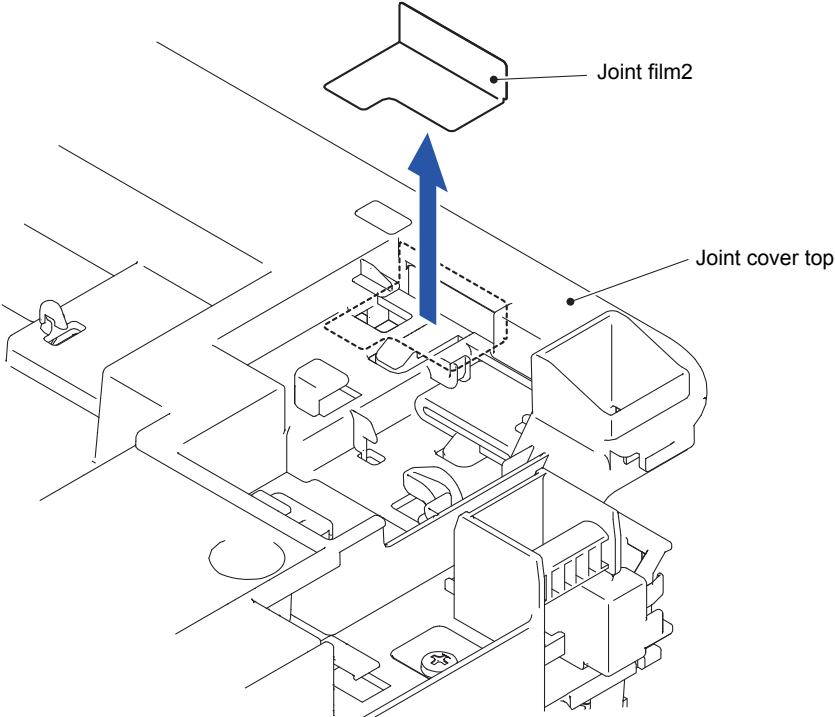

Fig. 3-162

9.41 Joint Cover Top

■ A4 model

(1) Remove the Lock claw and remove the Pull arm guide from the Joint cover top.

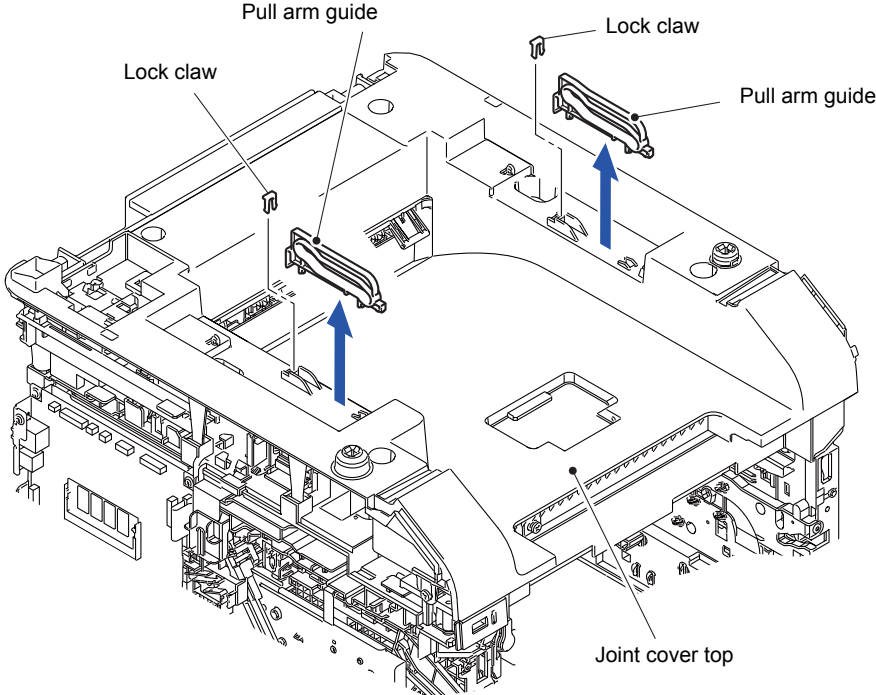

Fig. 3-163

(2) Remove the eight Taptite bind B M4x12 screws from the Joint cover top.

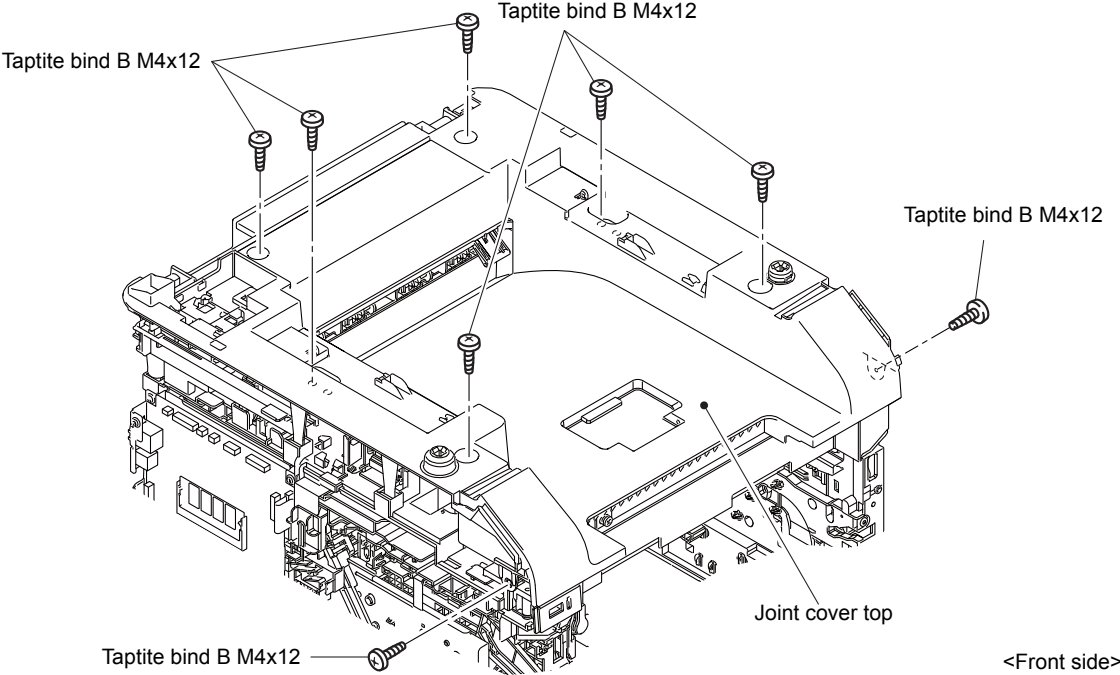

Fig. 3-164

- (3) Release the eight Hooks and remove the Joint cover top from the Main body.

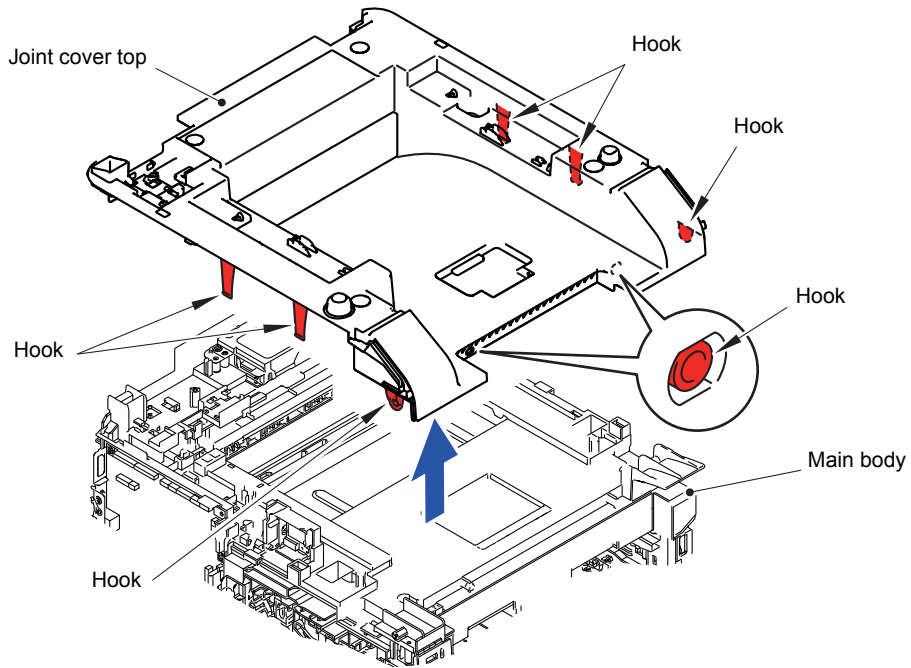

Fig. 3-165

■ Legal model

- (1) Remove the Screw pan (S/P washer) M3.5x6 screw and remove the Modem FG harness from the Main PCB plate.
- (2) Disconnect the Modem flat cable (CN28) from the Main PCB ASSY.

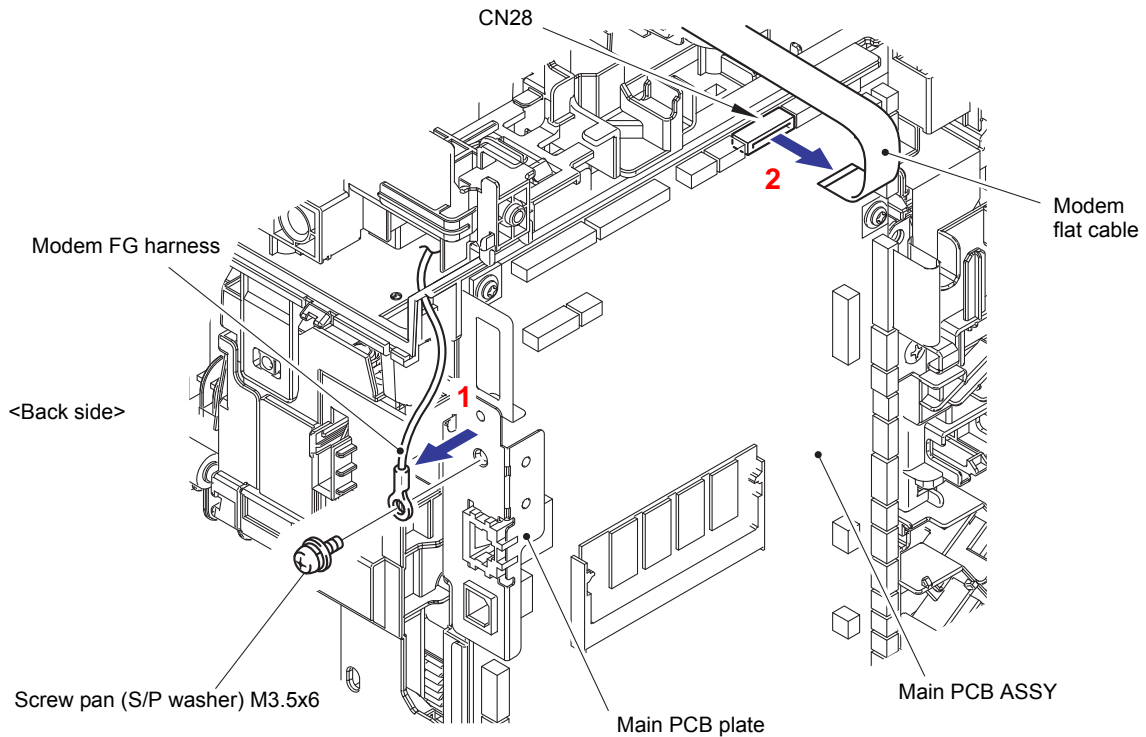

Fig. 3-166

- (3) Remove the eight Taptite bind B M4x12 screws from the Joint cover top.

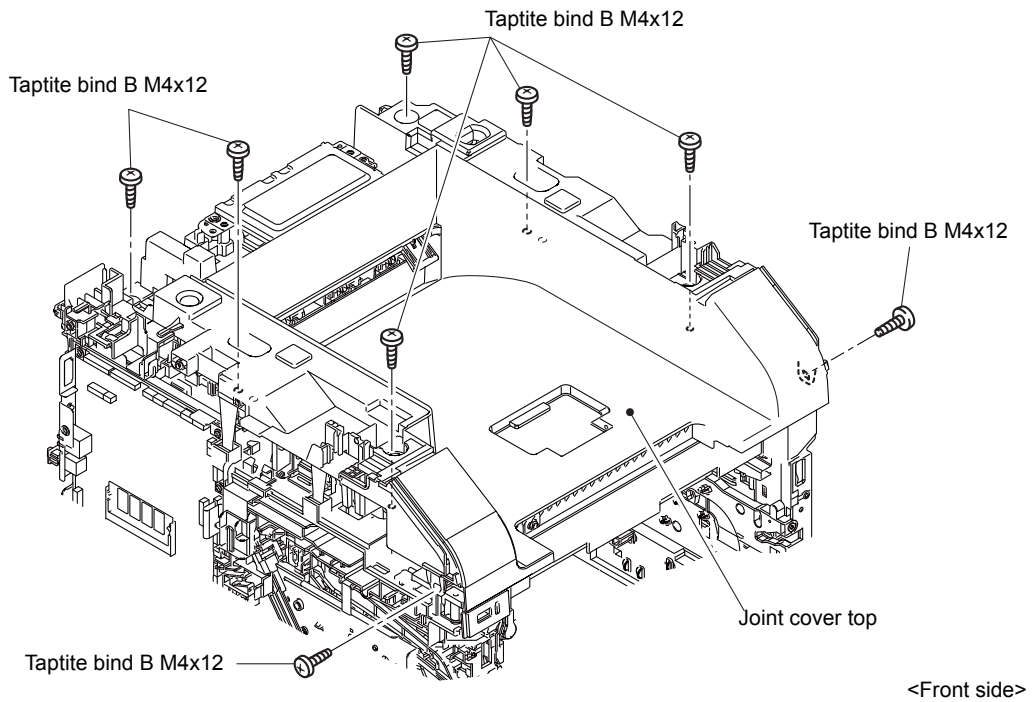

Fig. 3-167

- (4) Remove the Screw pan (S/P washer) M3.5x6 screw and remove the Modem ground harness from the High-voltage power supply PCB ASSY.

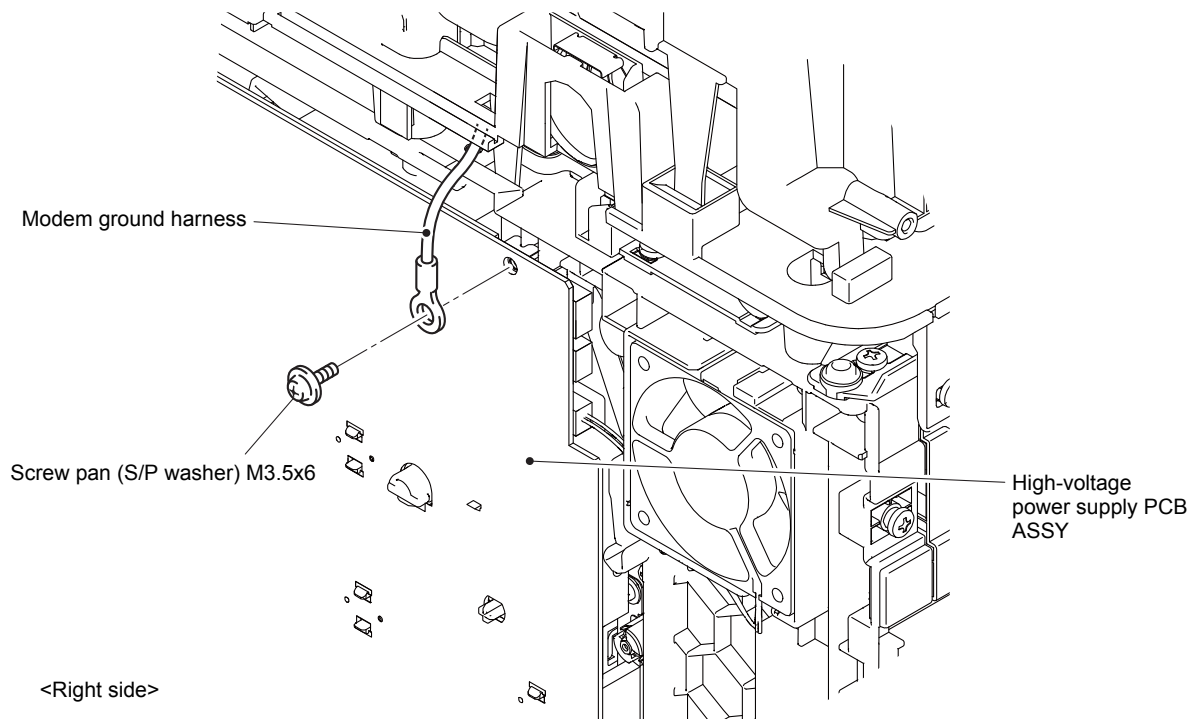

Fig. 3-168

- (5) Release the two Hooks A and release the two Hooks B.
- (6) Release the four Hooks C and lift the Joint cover top in the direction of the arrow.
- (7) Slide the Joint cover top from the four Hooks D and remove it from the Main body.

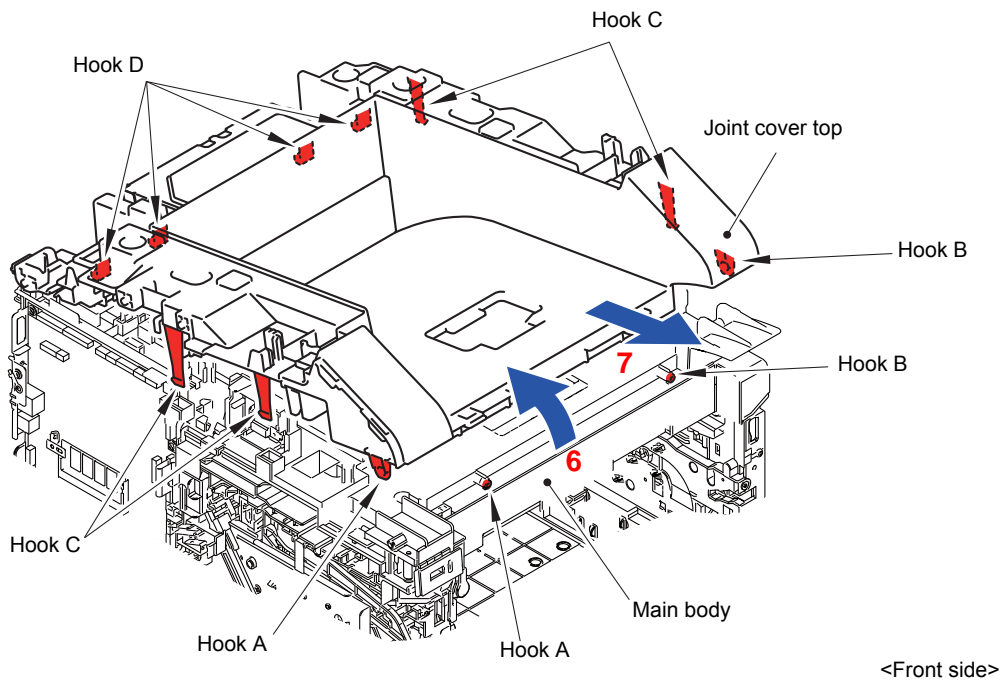

Fig. 3-169

- (8) Release the Hook and remove the two Flat cores of the Modem flat cable from the Back cover upper.

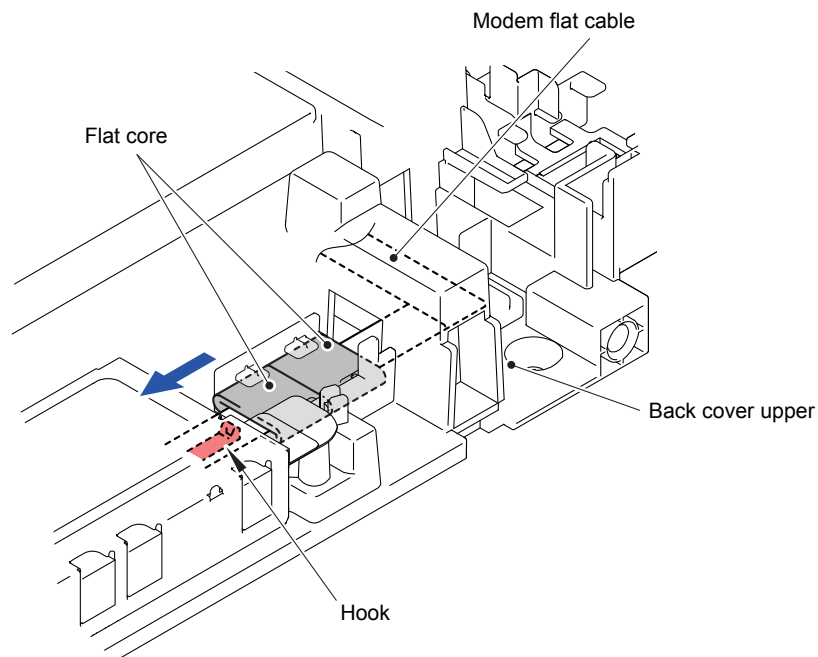

Fig. 3-170

- (9) Remove the two Taptite bind B M4x12 screws and remove the Modem shield cover from the Joint cover top.

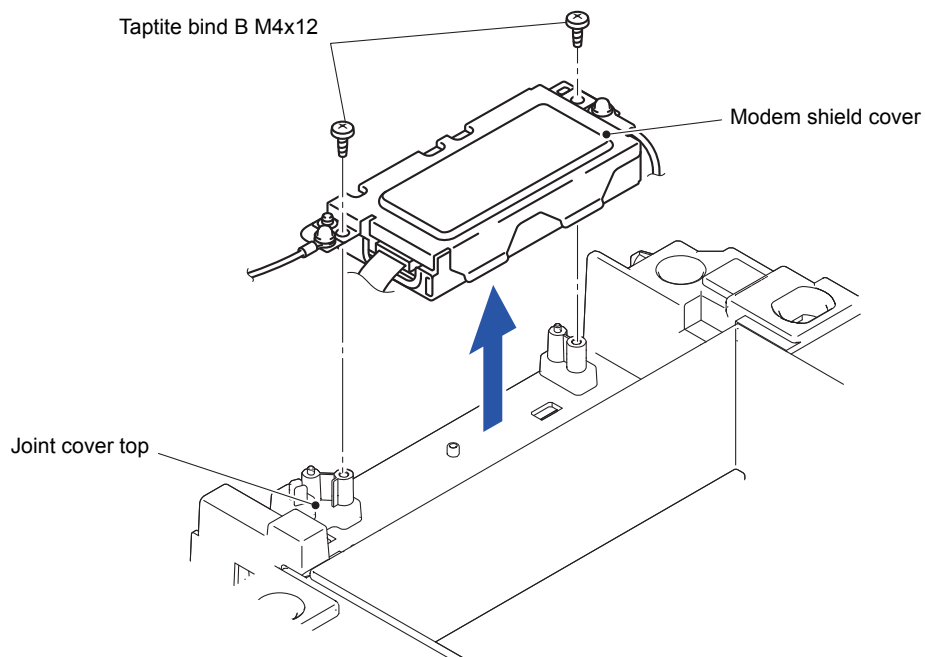

Fig. 3-171

Harness routing: Refer to “[20 Modem PCB ASSY \(Legal model\)](#)”

9.42 Modem PCB ASSY/Modem Flat Cable

Memo:

Follow the procedures (8) to (11) in the case of the Legal model.

■ **A4 model**

- (1) Remove the Screw pan (S/P washer) M3.5x6 screw and remove the Modem FG harness.
- (2) Disconnect the Modem flat cable (CN28) from the Main PCB ASSY.

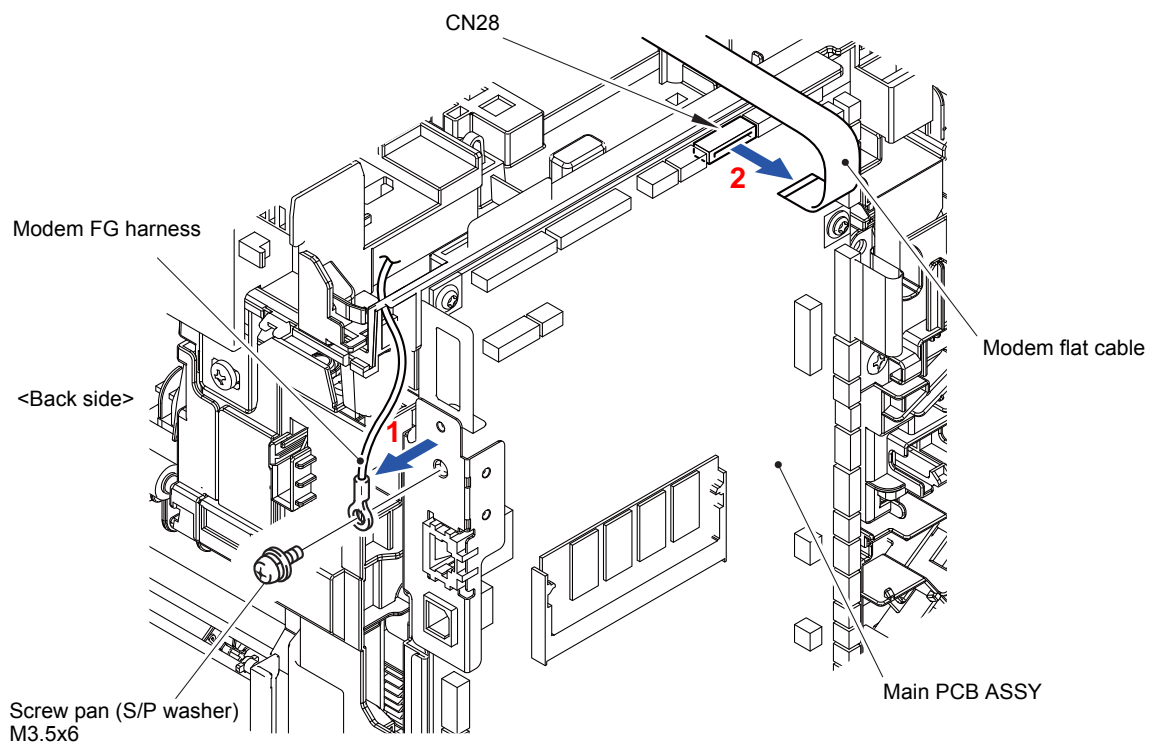

Fig. 3-172

- (3) Release the wiring of the FG harness from the Back cover upper.
- (4) Release the Hook and remove the two Flat cores of the Modem flat cable from the Back cover upper.

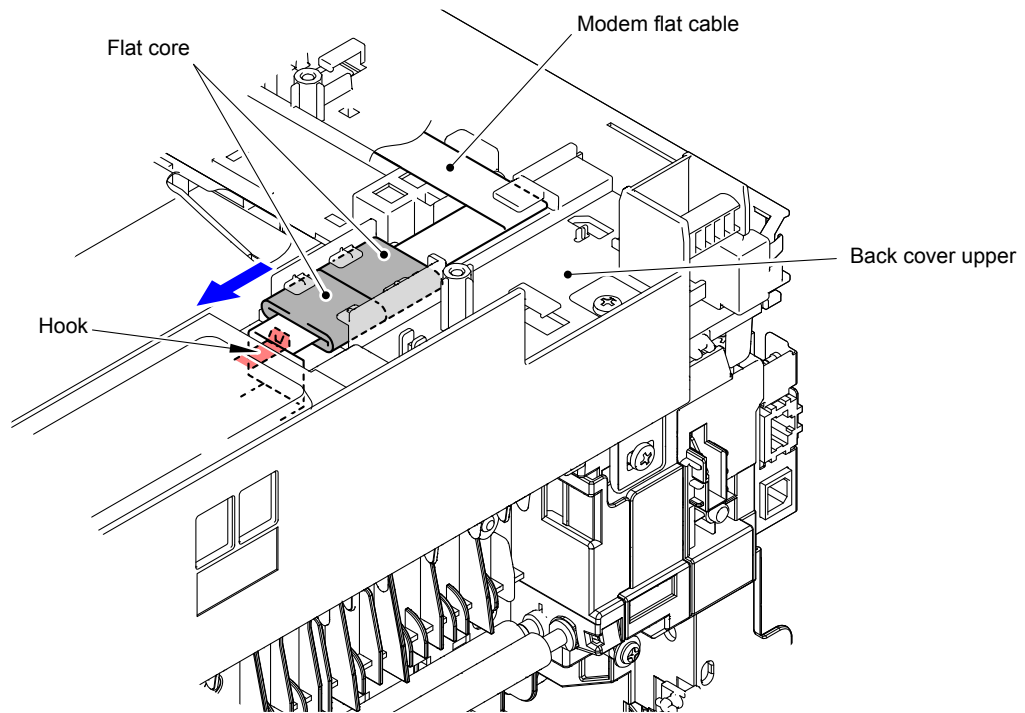

Fig. 3-173

- (5) Remove the Screw pan (S/P washer) M3.5x6 screw and remove the Modem ground harness from the High-voltage power supply PCB ASSY.
- (6) Disconnect the wiring of the Modem ground harness.

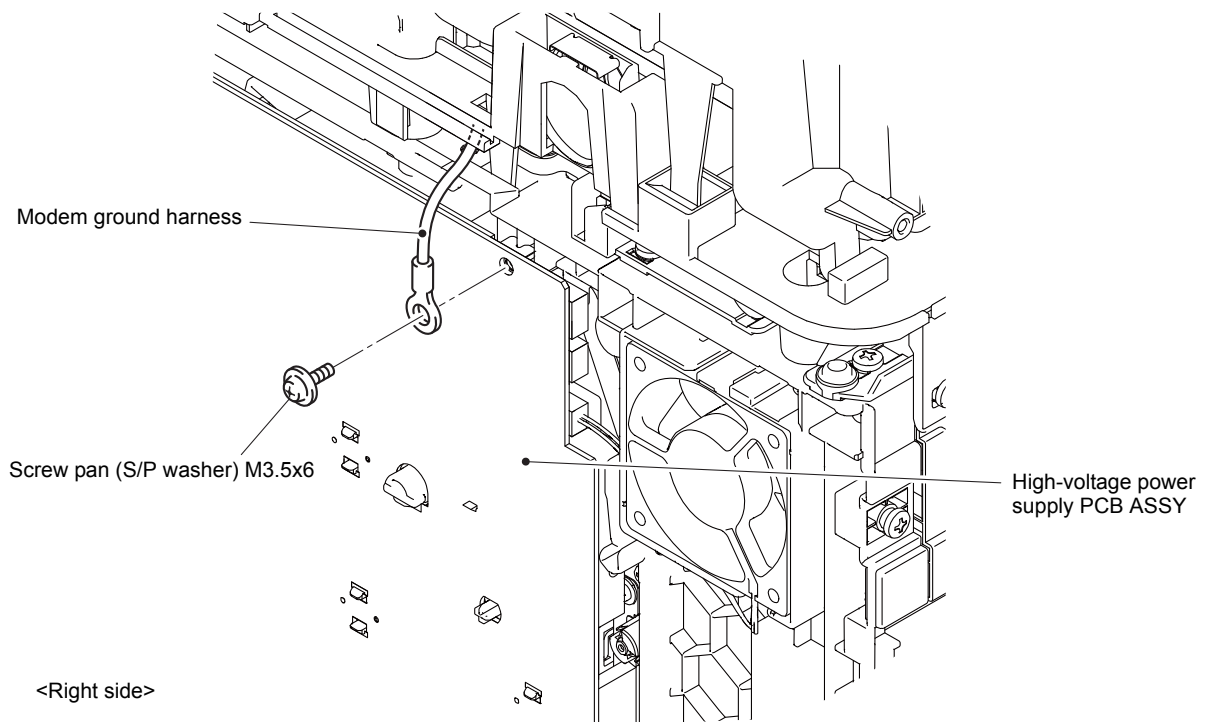

Fig. 3-174

- (7) Remove the two Taptite bind B M4x12 screws and remove the Modem shield cover from the Back cover upper.

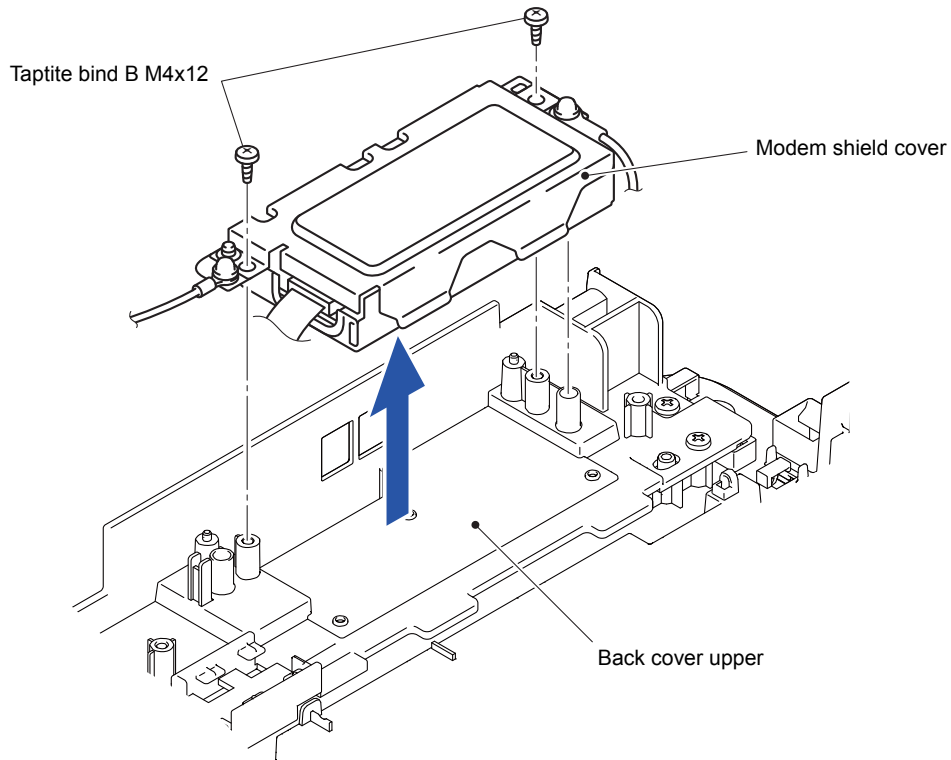

Fig. 3-175

■ **A4 model/Legal model**

- (8) Disconnect the Modem flat cable (CN1) from the Modem PCB ASSY.
(9) Remove the Flat core from the Modem flat cable.

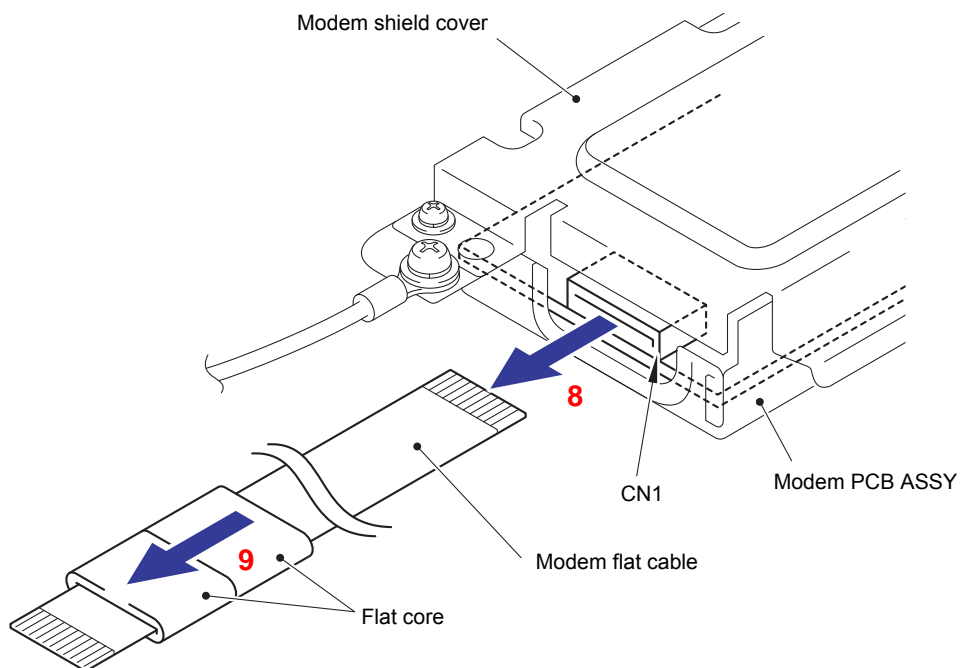

Fig. 3-176

Note:

- After disconnecting flat cables, check that each cable is not damaged at its end or short-circuited.
- When connecting flat cables, do not insert them at an angle. After insertion, check that the cables are not at an angle.

<How to fold the Modem flat cable>

■ **A4 model**

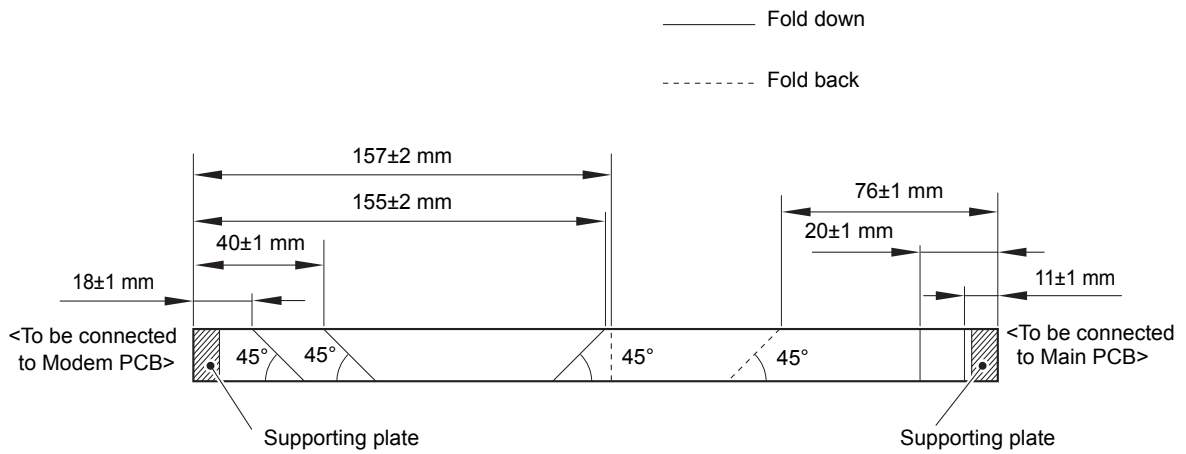

Fig. 3-177

■ **Legal model**

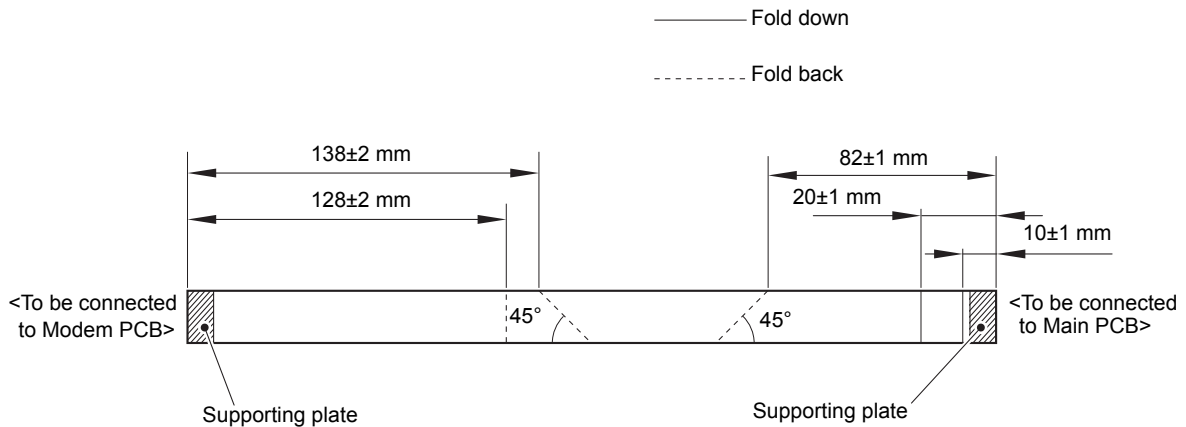

Fig. 3-178

(10) Remove the Screw pan (S/P washer) M3.5x6 screw and remove the Modem shield cover from the Modem shield plate.

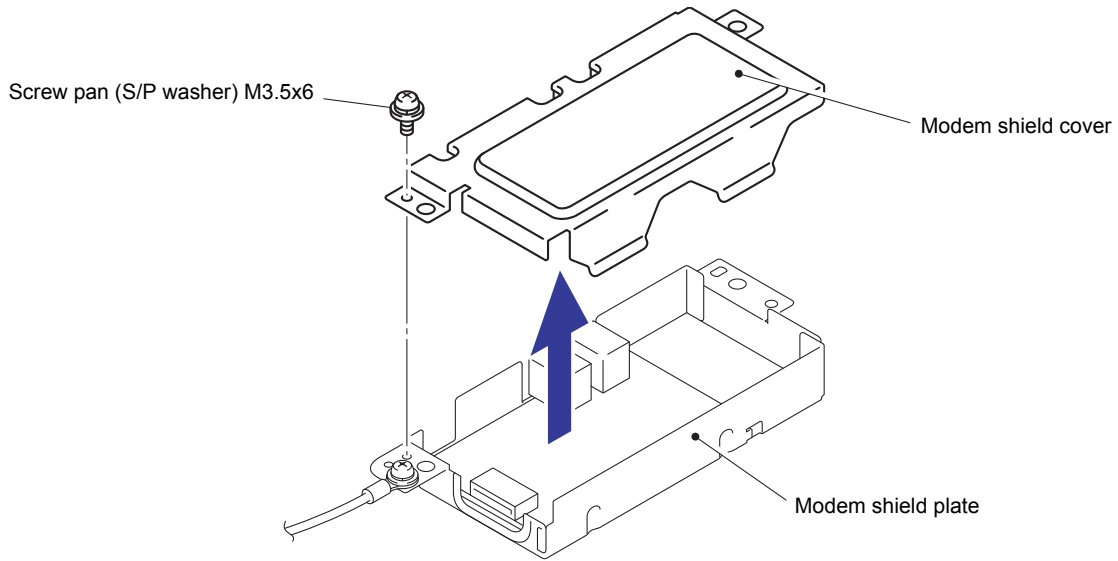

Fig. 3-179

(11) Remove the two Taptite cup S M3x6 SR screws and remove the Modem PCB ASSY from the Modem shield plate.

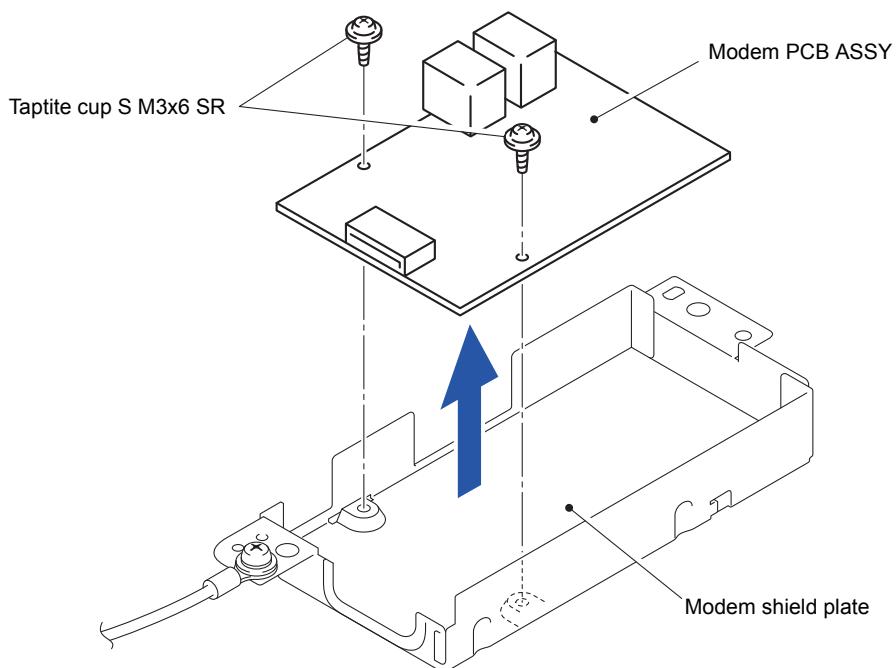

Fig. 3-180

Harness routing: Refer to “[19](#) Modem PCB ASSY (A4 model)”, “[20](#) Modem PCB ASSY (Legal model)”

9.43 Back Cover Upper (A4 Model Only)

- (1) Remove the four Taptite bind B M4x12 screws from the Back cover upper.
- (2) Release the two Hooks and remove the Back cover upper from the Main body.

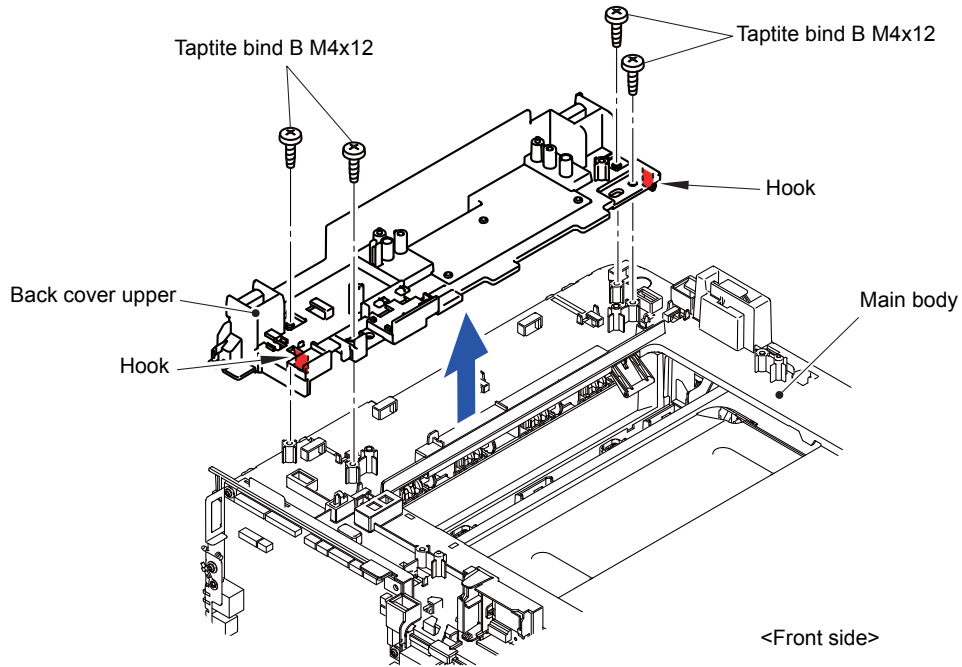

Fig. 3-181

9.44 Joint Cover USB ASSY

- (1) Disconnect the Connector (CN11) from the Main PCB ASSY.

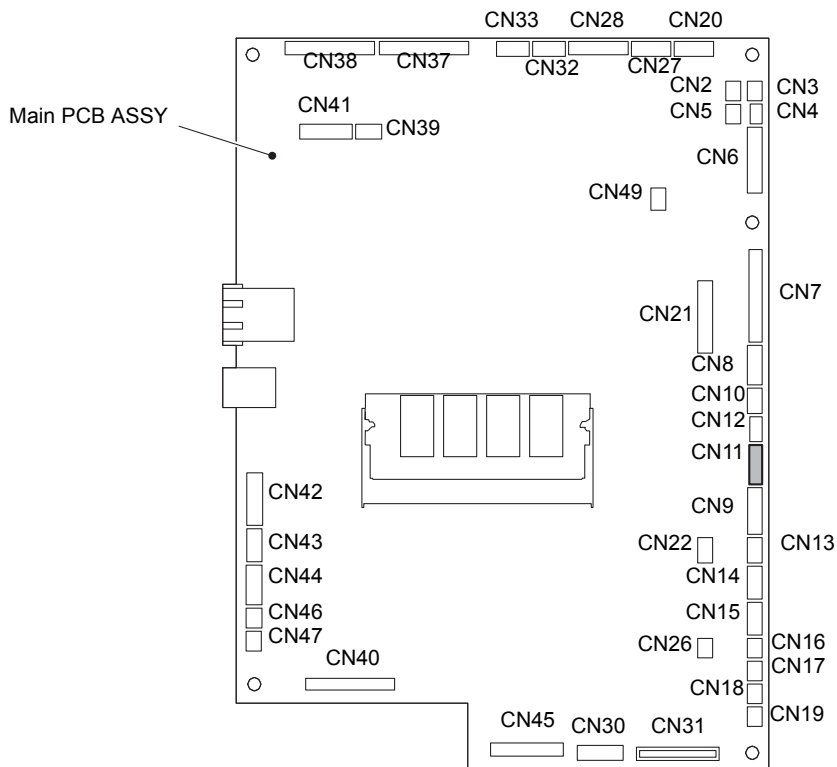

Fig. 3-182

- (2) Disconnect the wiring of the Main USB host harness ASSY.
- (3) Remove the one Taptite bind B M4x12 screw.

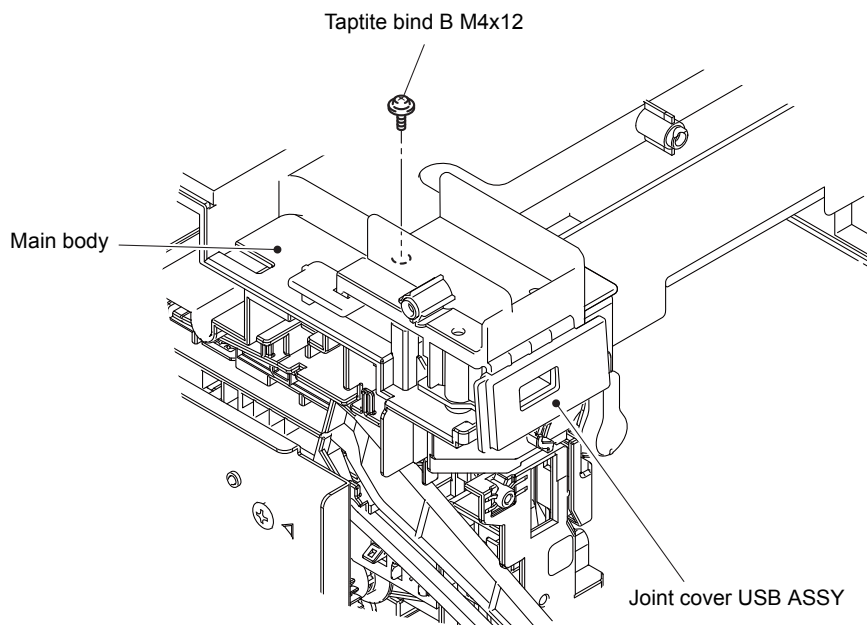

Fig. 3-183

- (4) Release the four Hooks to remove the Joint cover USB ASSY from the Main body.

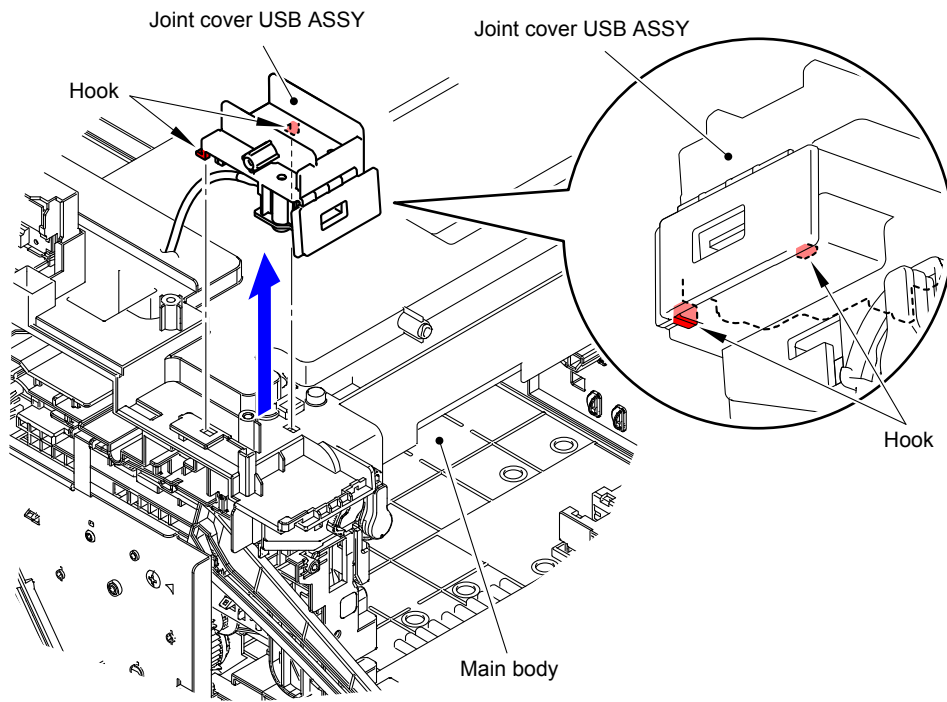



Fig. 3-184

Harness routing: Refer to “ USB-Host”

9.45 Wireless LAN PCB

(1) Release the three Hooks and remove the Wireless LAN PCB from the Main body.

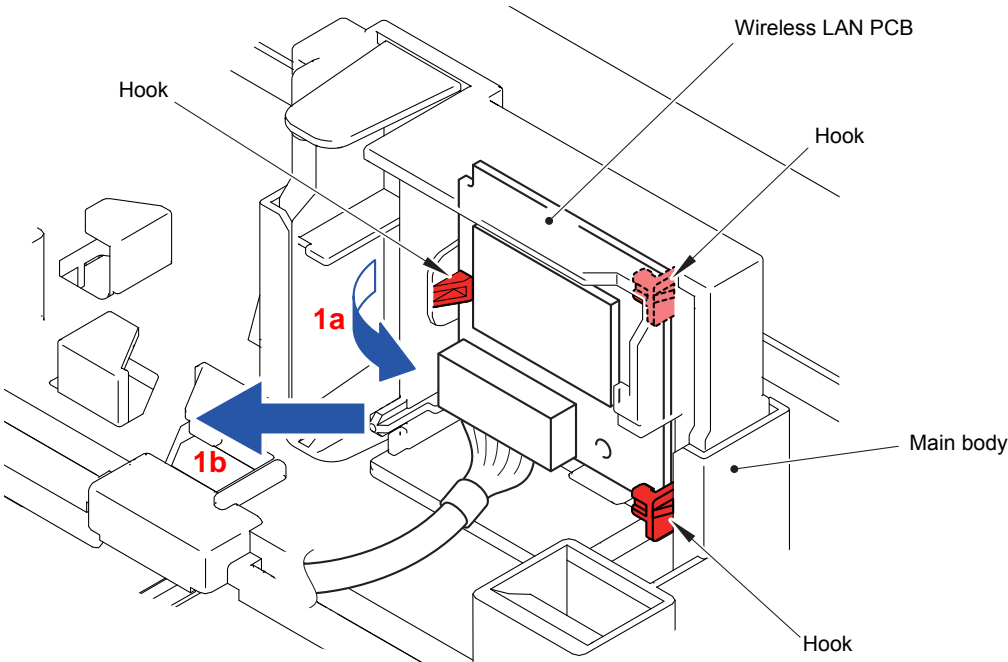

Fig. 3-185

(2) Disconnect the Main Wireless LAN harness ASSY from the Wireless LAN PCB.

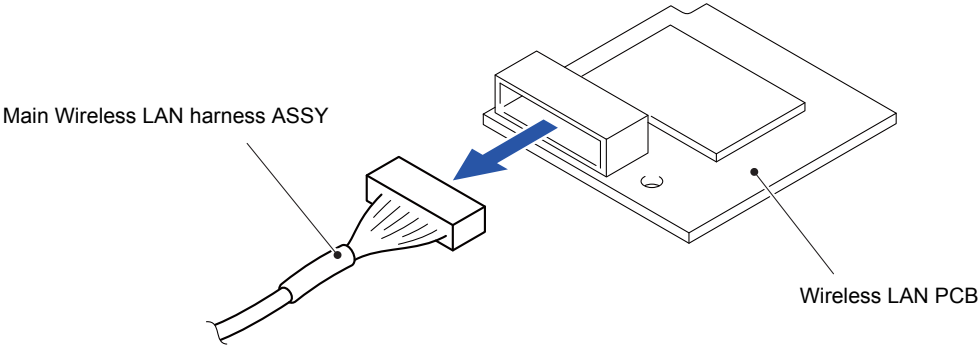

Fig. 3-186

Harness routing: Refer to “ [22 Wireless LAN PCB](#)”

9.46 Main PCB ASSY

Note: Backup of machine information

Before starting disassembly work, back up the machine information and user setting information.

(Refer to "1.3.13 Backup of machine information (Function code 41)" in Chapter 5.)

After replacing the PCB, restore the backup data to a new PCB.

- (1) Disconnect the twenty five Connectors (CN2, CN3, CN4, CN5, CN6, CN8, CN9, CN10, CN12, CN13, CN14, CN15, CN16, CN17, CN18, CN19, CN21, CN30, CN40, CN42, CN43, CN44, CN46, CN47 and CN49) and three Flat cables (CN7, CN31 and CN45) from the Main PCB ASSY.

Note:

- After disconnecting flat cables, check that each cable is not damaged at its end or short-circuited.
- When connecting flat cables, do not insert them at an angle. After insertion, check that the cables are not at an angle.

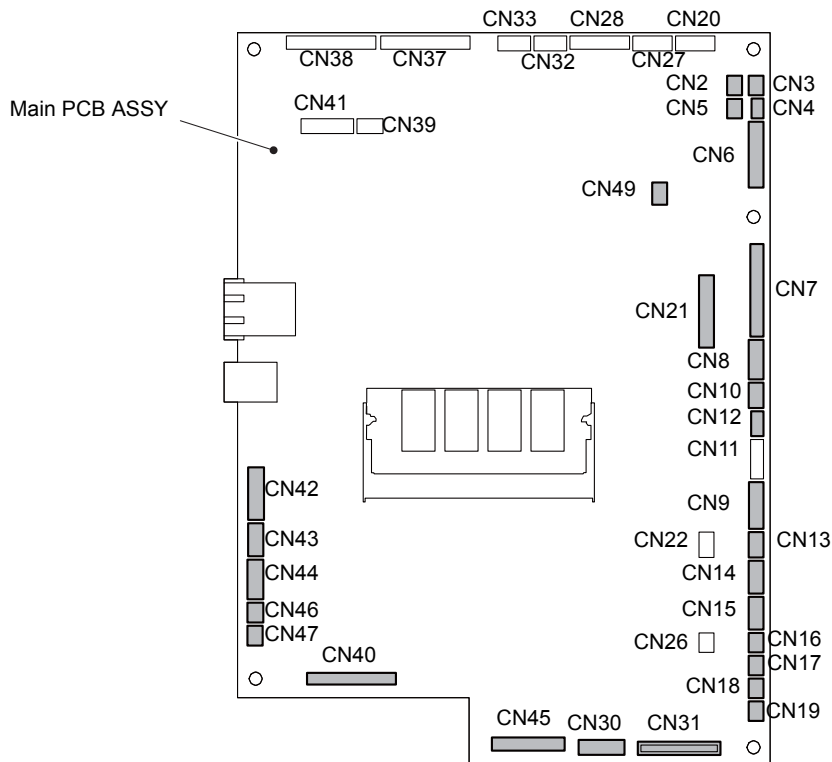

Fig. 3-187

- (2) Remove the three Screw bind M3x6 screws and remove the Main PCB ASSY from the Main body.

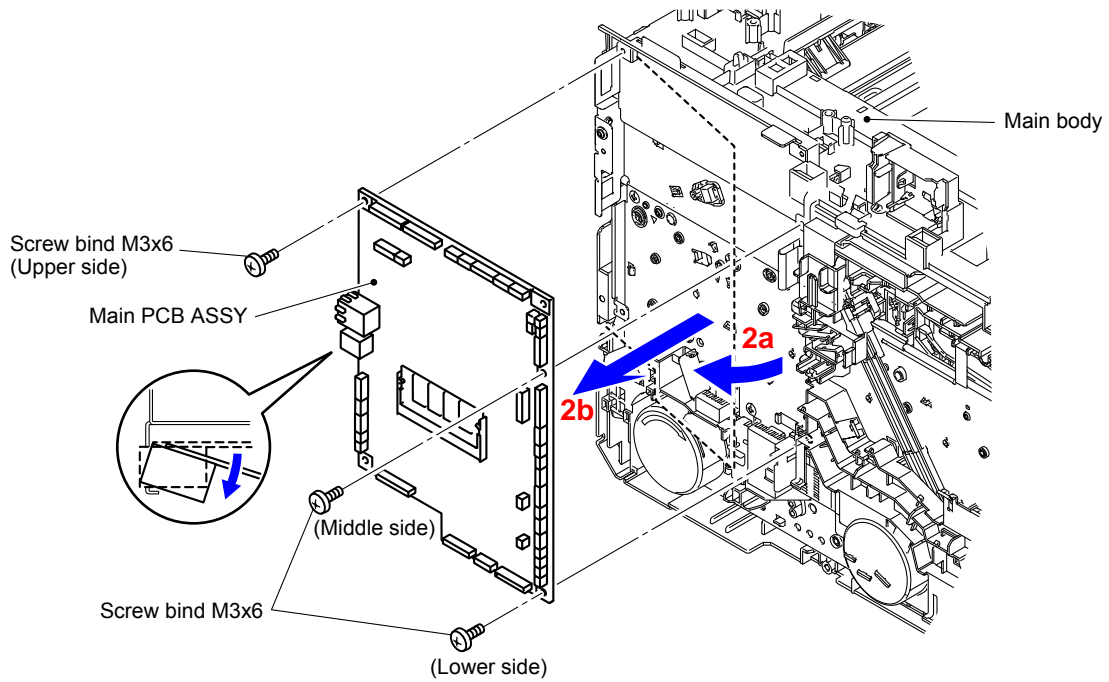

Fig. 3-188

Note:

Note that the tightening torque is different between the upper/middle side and lower side of the Screw bind M3x6.

Upper/Middle side: 0.5 ± 0.05 N·m

Lower side: 0.8 ± 0.1 N·m

9.47 Laser Unit Flat Cable/Laser Unit

- (1) Remove the seven Taptite bind B M4x12 screws from the Joint cover base ASSY.
- (2) Remove the two Taptite bind B M4x12 screws from the back of the Joint cover base ASSY.

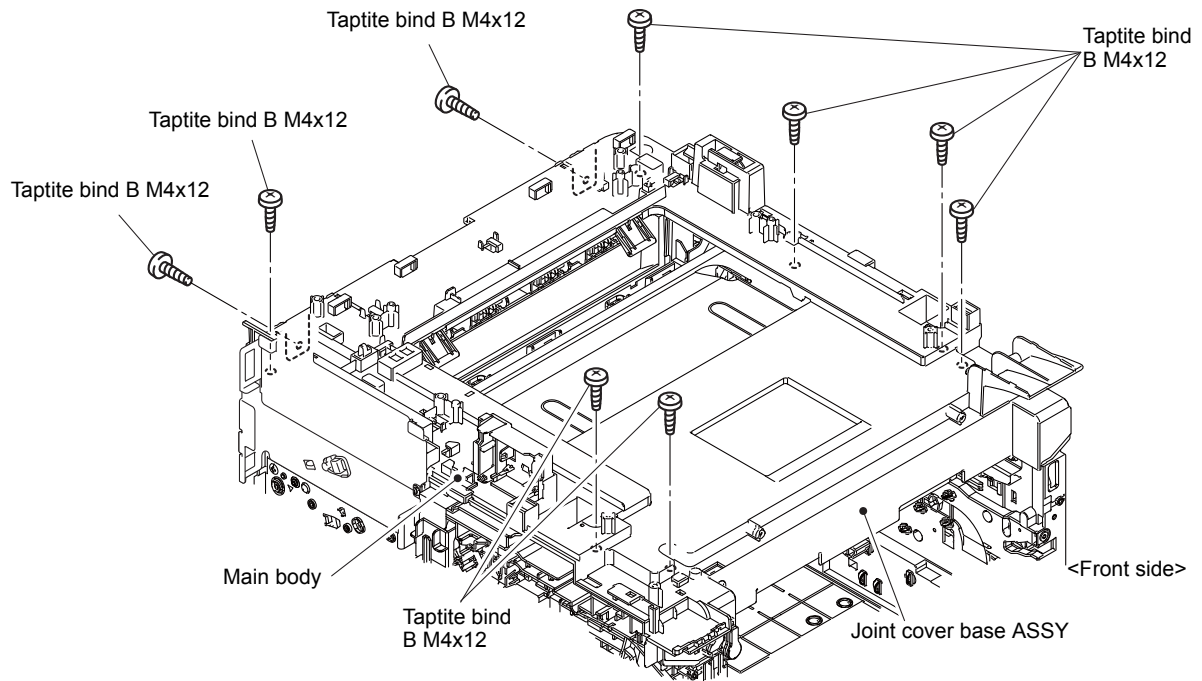

Fig. 3-189

- (3) Release the three Hooks 1. Release the other seven Hooks and remove the Joint cover base ASSY from the Main body.

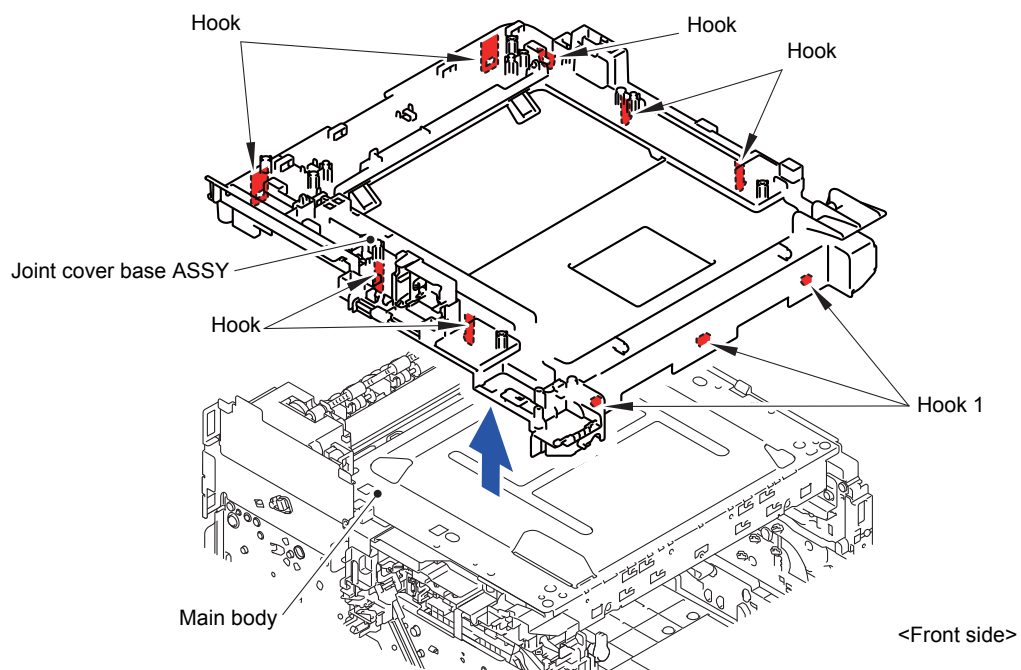

Fig. 3-190

- (4) Remove the six Taptite bind B M4x12 screws and four Taptite cup S M3x6 SR screws, and remove the Scanner cover plate from the Main body.

Assembling Note:

When assembling the six screws of the Taptite bind B M4x12, be sure to assemble them in the order shown in the figure.

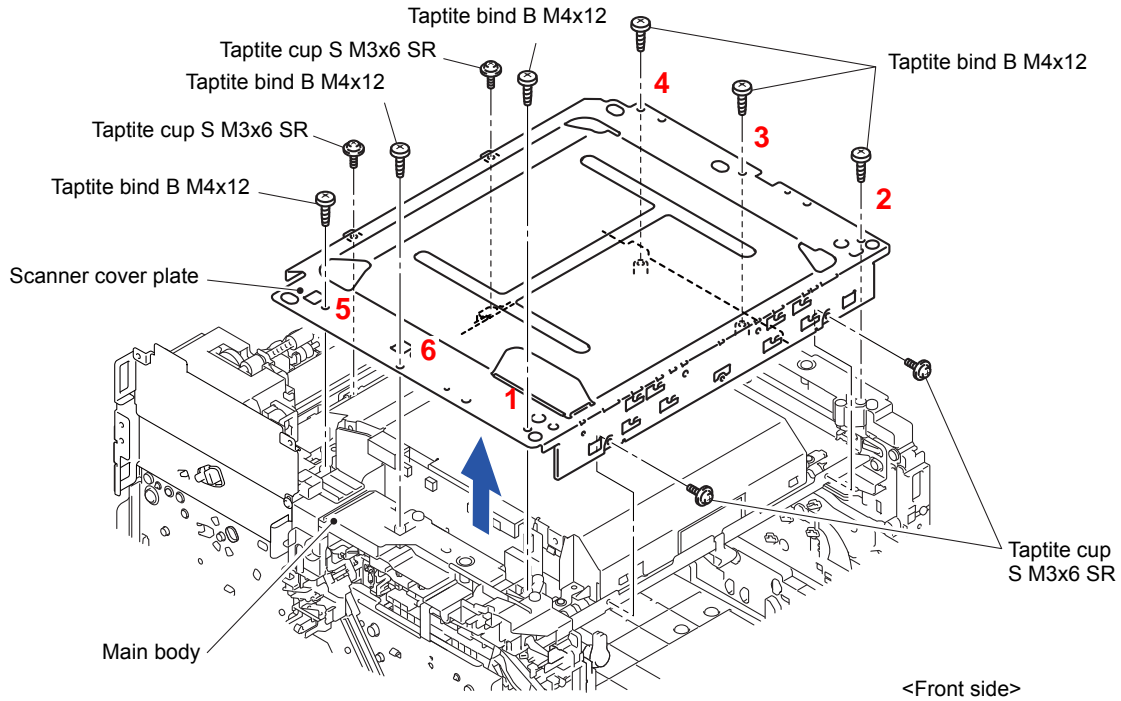

Fig. 3-191

- (5) Disconnect the Laser unit flat cable from the Laser unit and release the wiring.

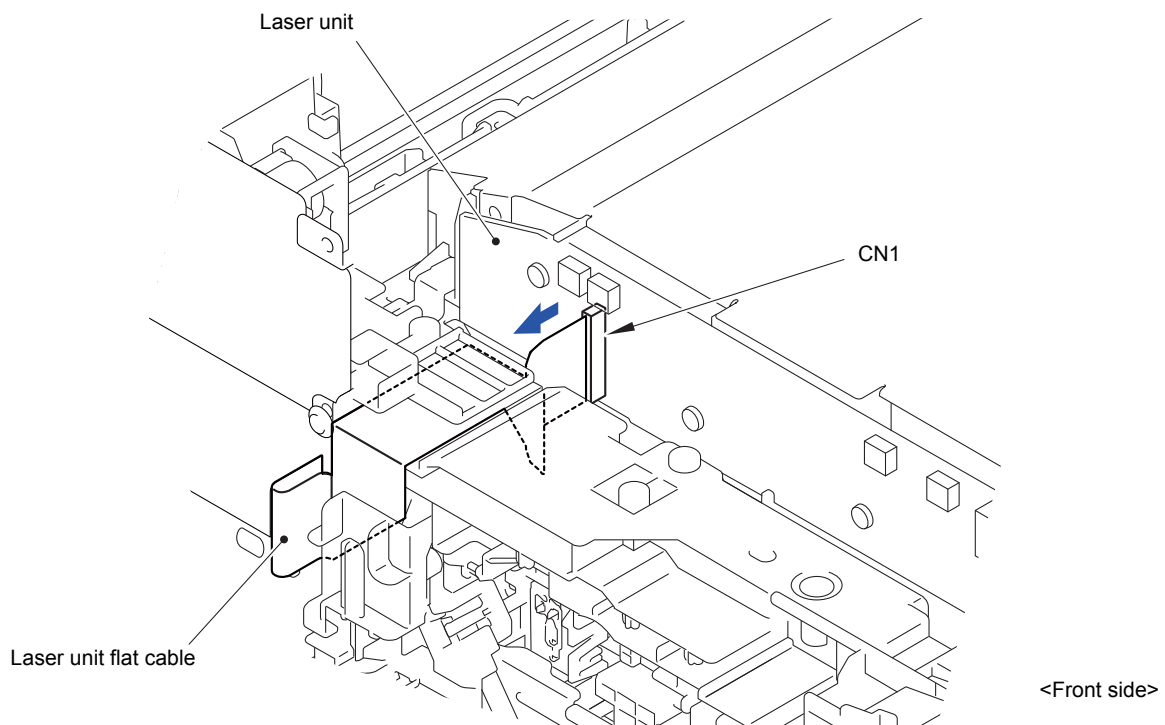

Fig. 3-192

Note:

- After disconnecting flat cables, check that each cable is not damaged at its end or short-circuited.
- When connecting flat cables, do not insert them at an angle. After insertion, check that the cables are not at an angle.

<How to fold the Laser unit flat cable>

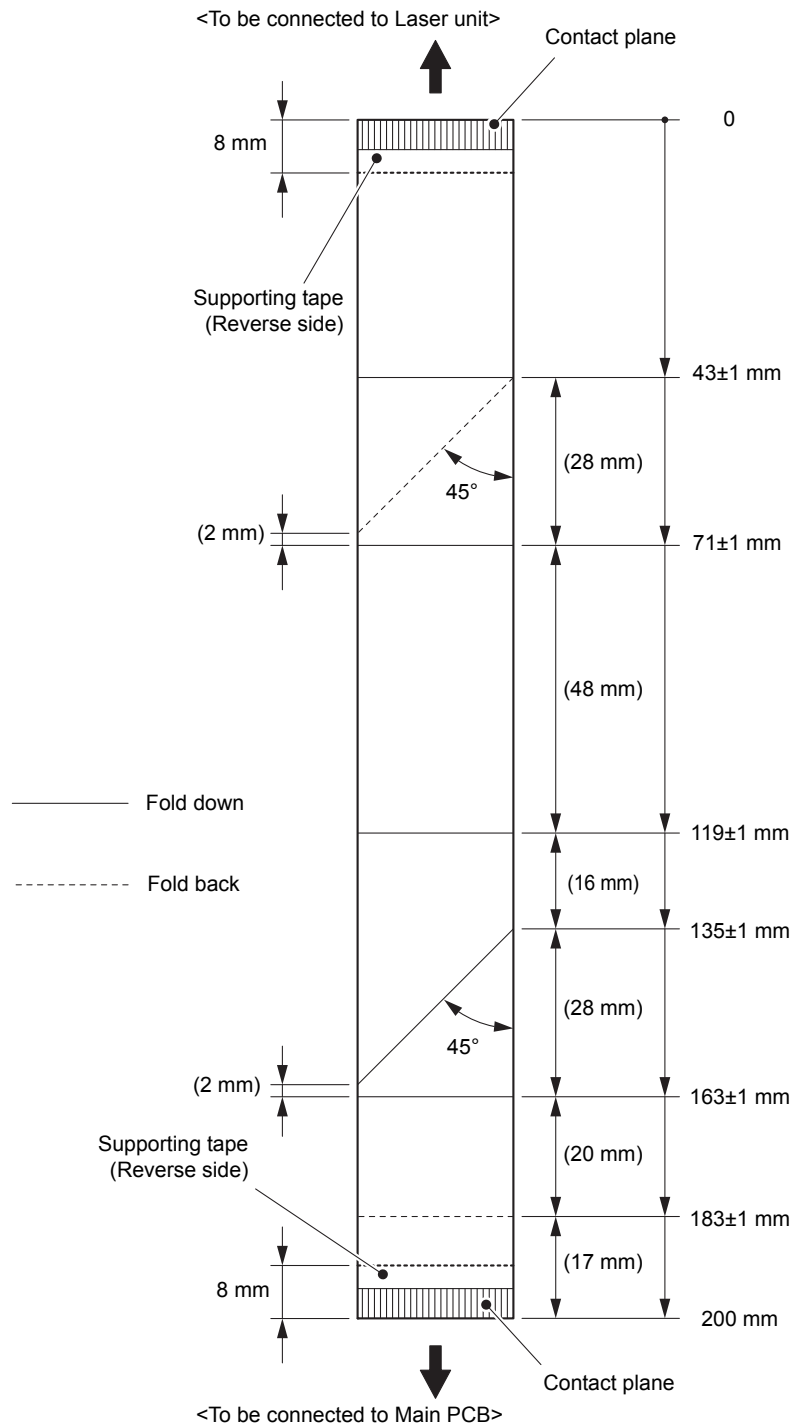

Fig. 3-193

- (6) Remove the five Taptite cup S M3x6 SR screws and remove the four Scanner holders from the Scanner plate.

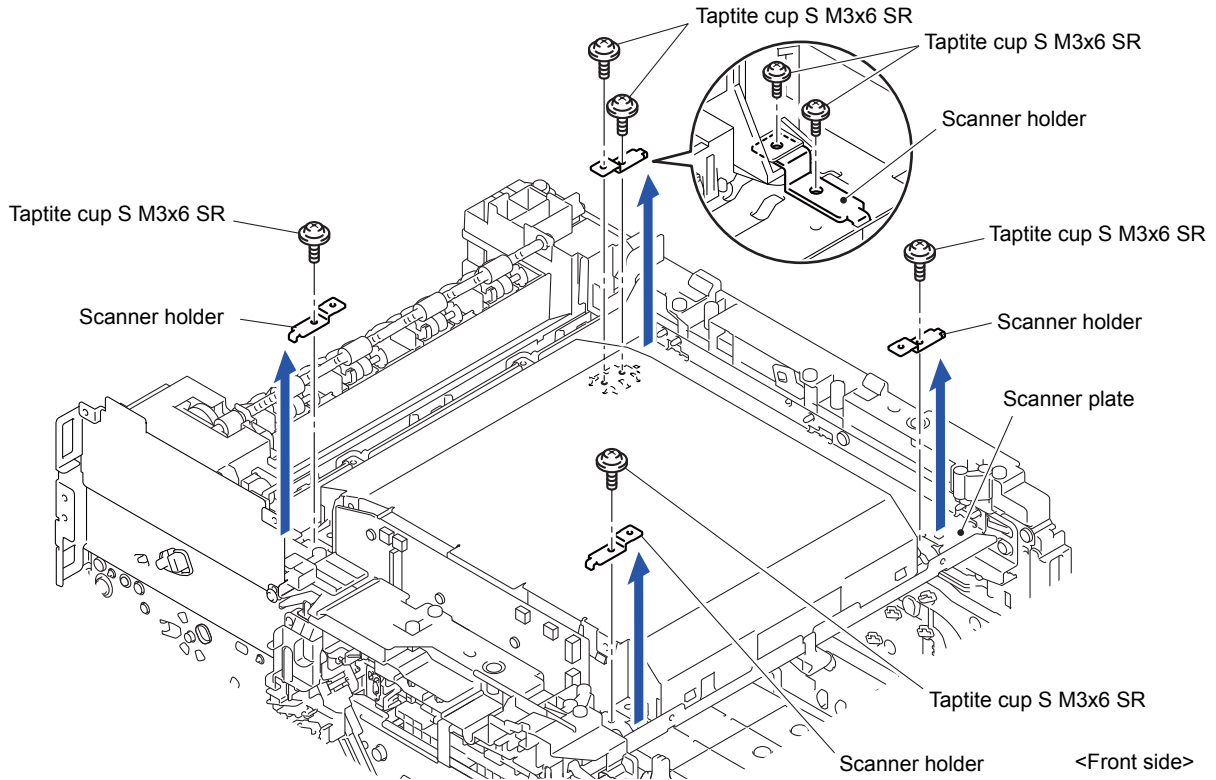

Fig. 3-194

Assembling Note:

- When assembling the Scanner holder to "A" of the Laser unit, be sure to use the Scanner holder of which "B" is a screw and not to use other Scanner holders.
- When assembling the Scanner holder to "A" of the Laser unit, be sure that the Scanner holder is placed as shown in the figure.

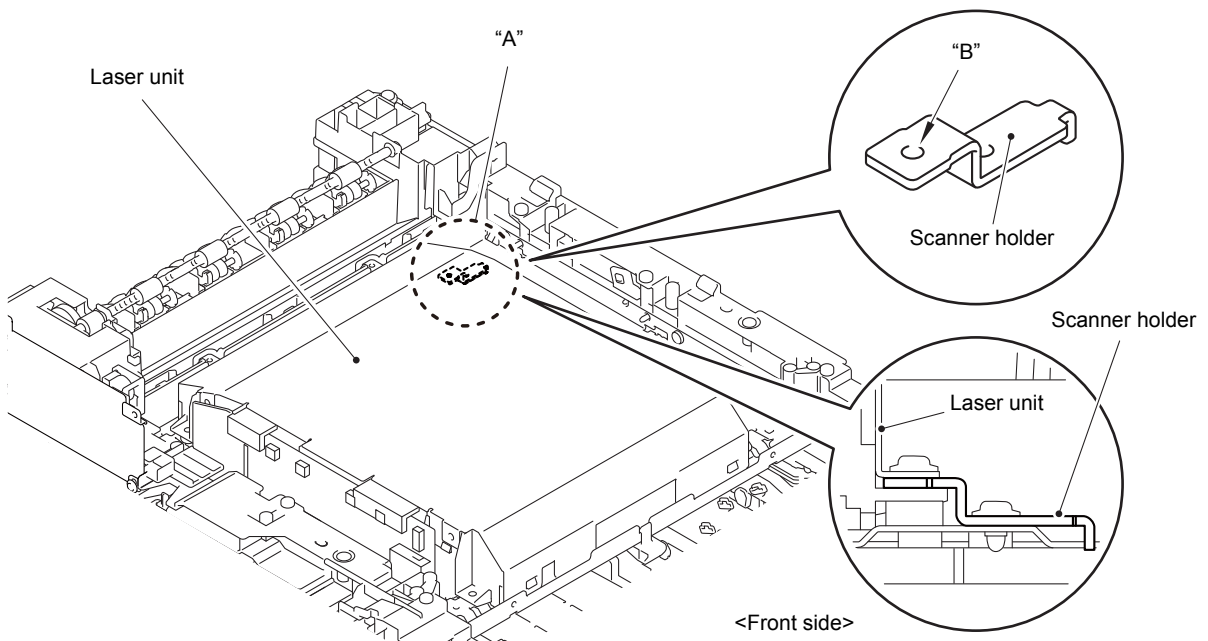

Fig. 3-195

- (7) Disconnect the Connector (CN8).
- (8) Remove the Laser unit from the Scanner plate.

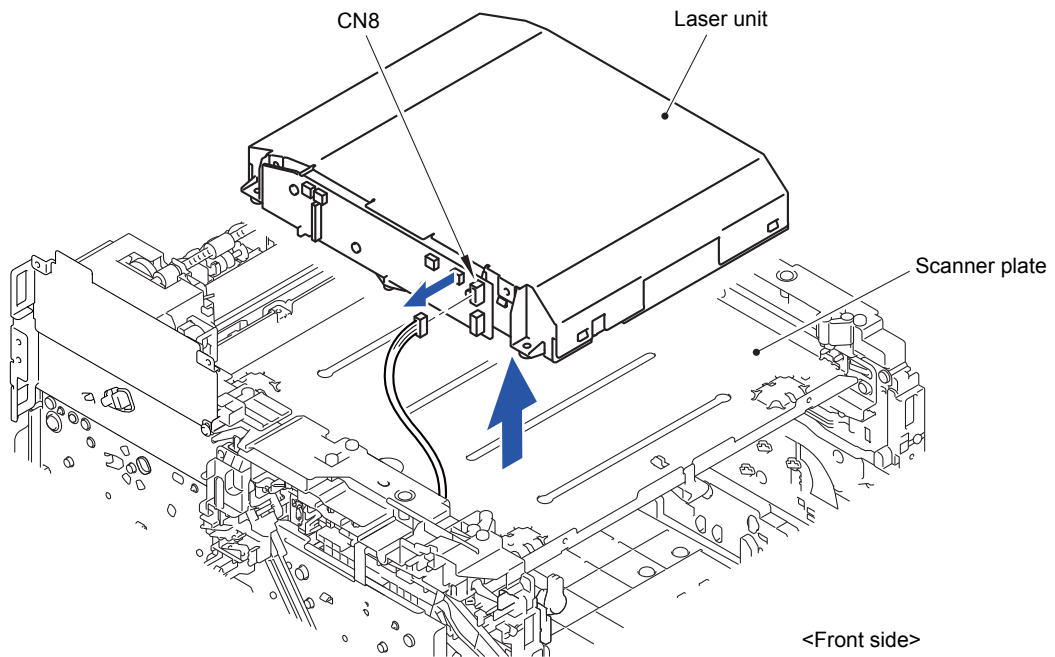

Fig. 3-196

Harness routing: Refer to “ **1 Laser Unit**”

9.48 Front Cover Sensor

- (1) Release the wiring of the Front cover sensor.
- (2) Release the two Hooks and remove the Front cover sensor from the Main body.

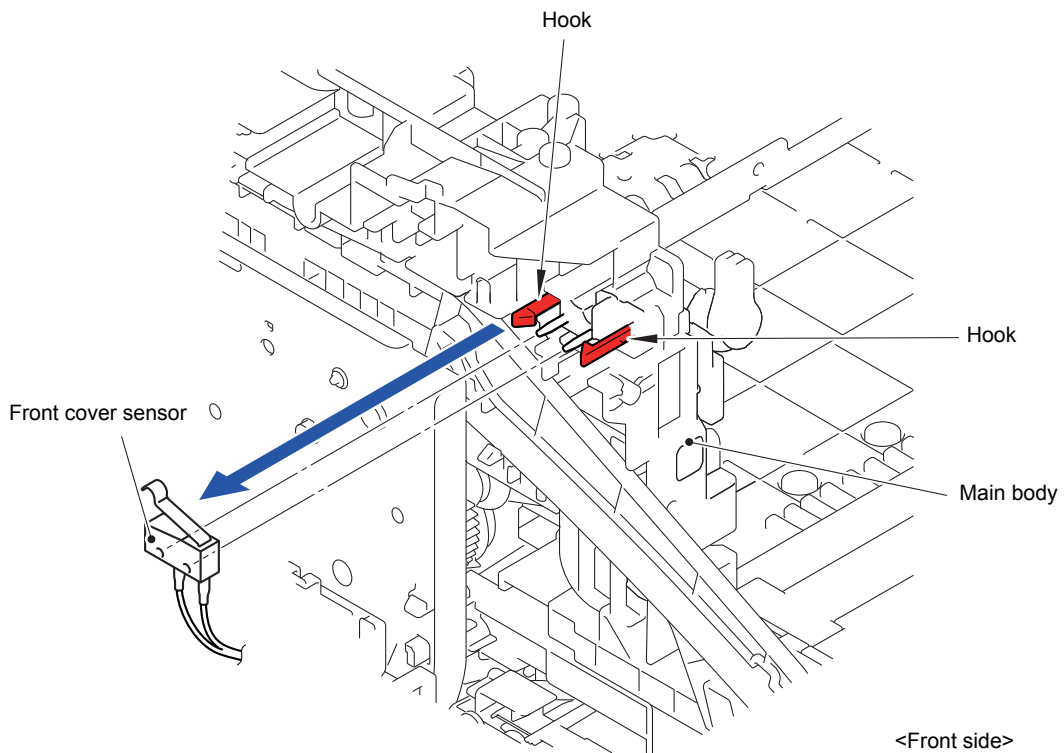

Fig. 3-197

Harness routing: Refer to “ **2 Process Drive Unit, Front Cover Sensor, Main Drive Unit**”

9.49 Process Drive Unit/Fuser Drive Gear Z25

- (1) Release all the wiring from the Wireless LAN cable rack.
- (2) Release the three Hooks and remove the Wireless LAN cable rack from the Main body.

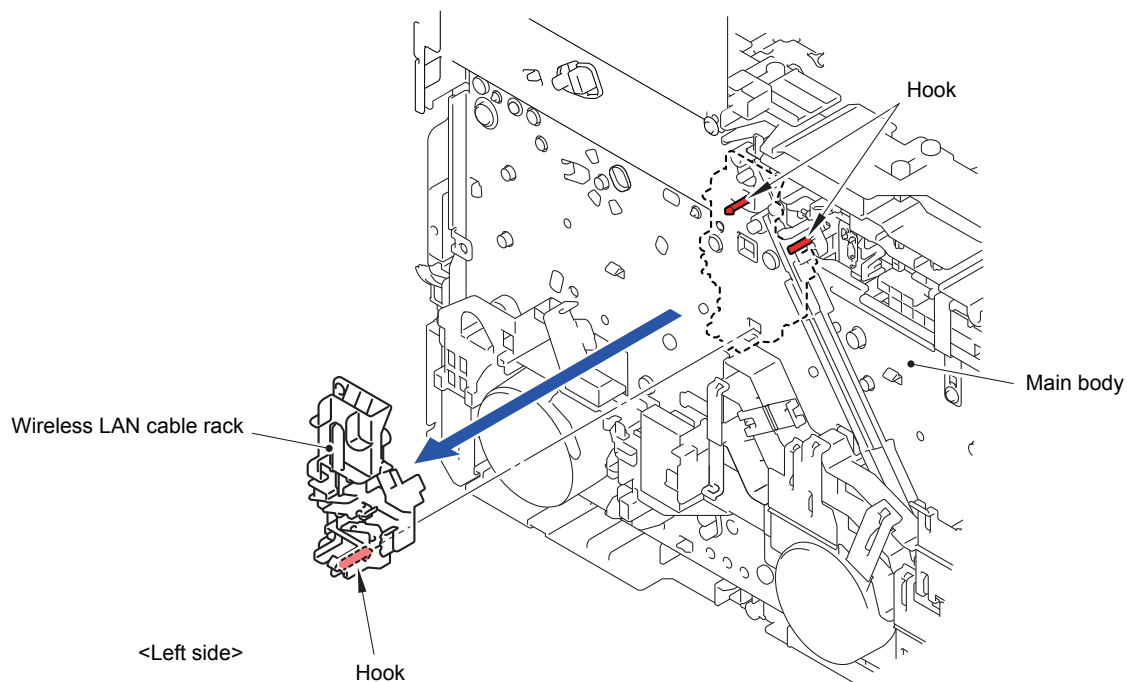

Fig. 3-198

- (3) Release the wiring of the Polygon motor harness.
- (4) Remove the two Taptite cup S M3x8 SR screws and remove the Side ground plate L from the Main body.

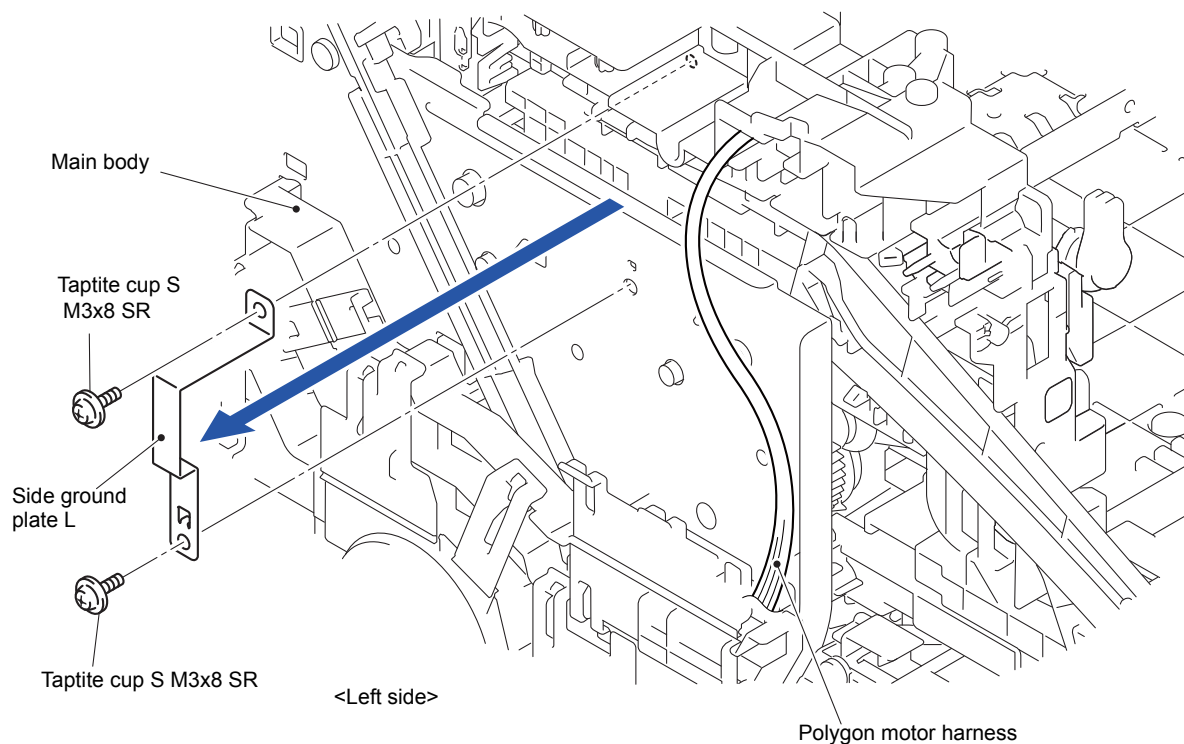

Fig. 3-199

- (5) Remove the two Screw bind M3x8 screws from the Main PCB plate.
Release the two Hooks and remove the Main PCB plate from the Main body.

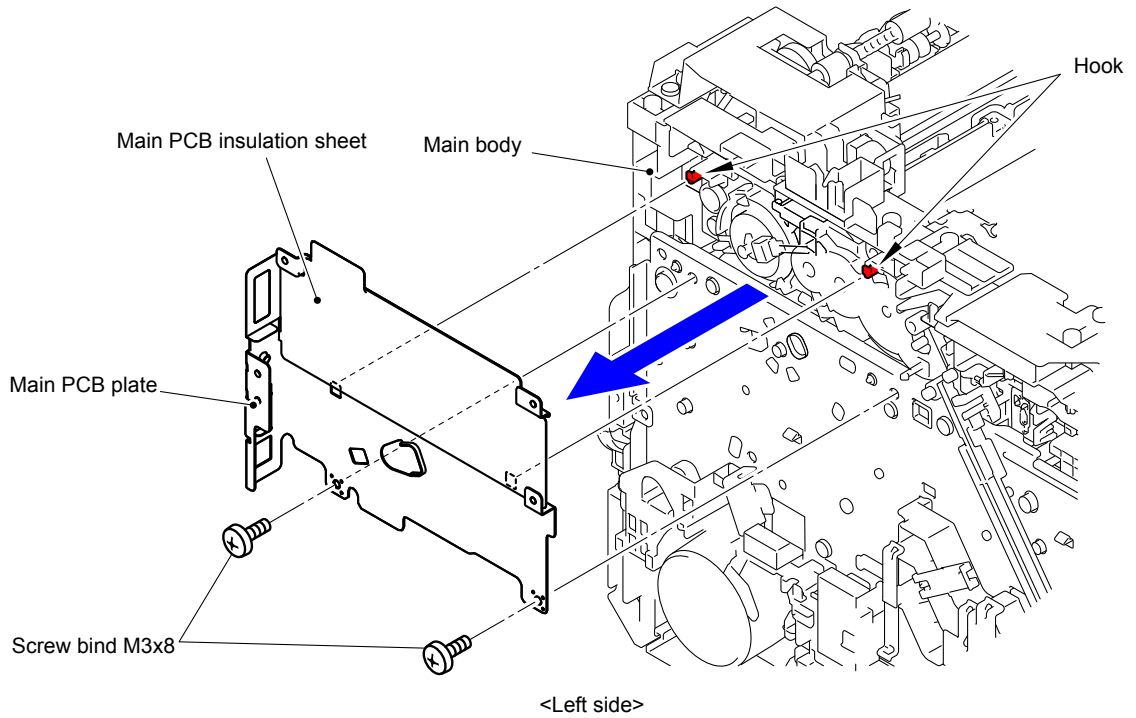

Fig. 3-200

- (6) Release all the wiring from the PF cable rack.
- (7) Remove the Taptite cup S M3x8 SR screw from the PF cable rack. Release the six Hooks and slide the PF cable rack in the direction of the arrow and remove it from the Main body.

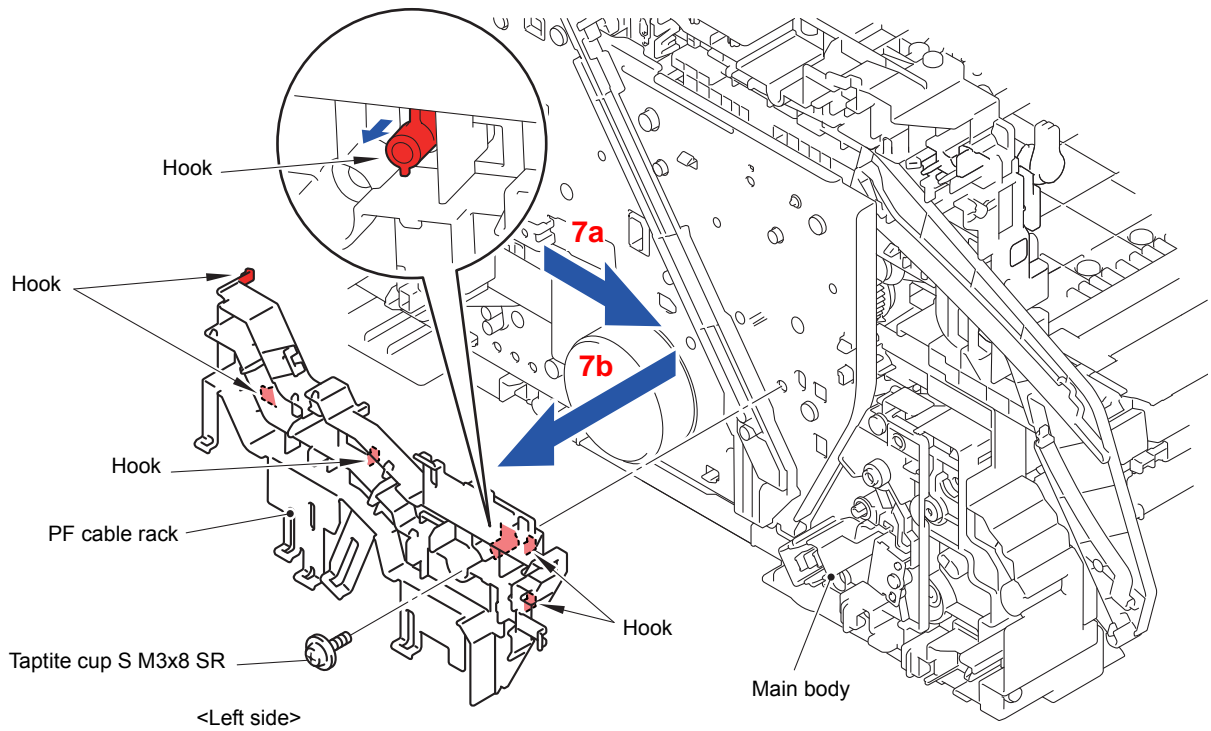

Fig. 3-201

(8) Remove the Mono color cam from the Main body.

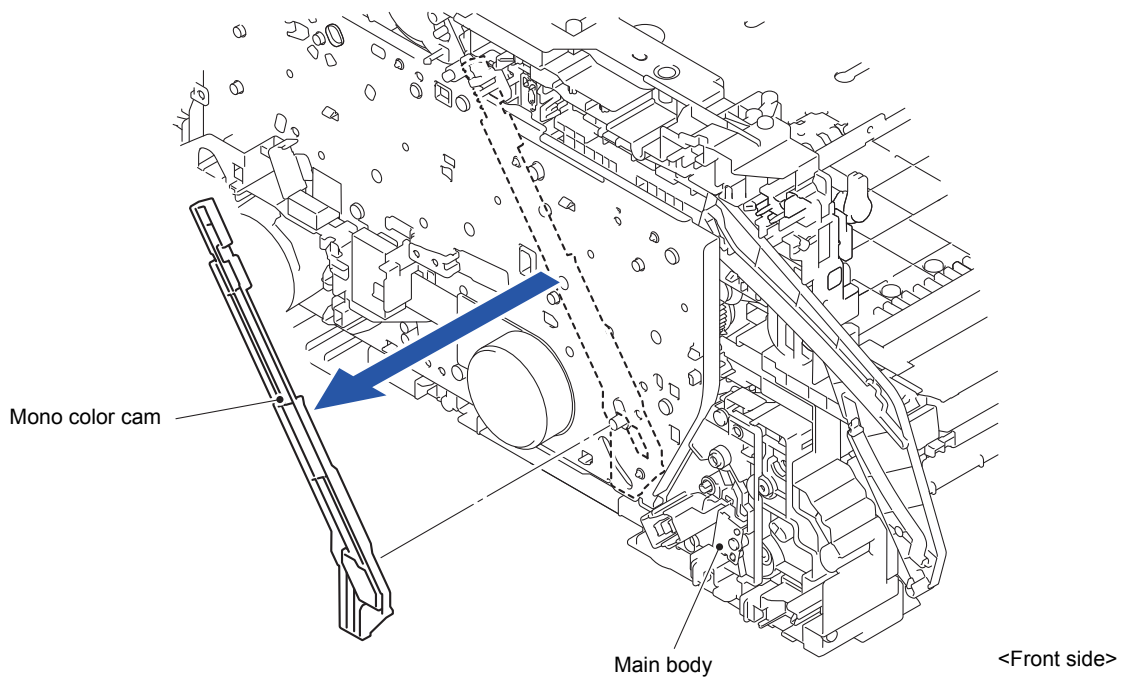

Fig. 3-202

Assembling Note:

When assembling the Mono color cam, be sure to check that the Forced develop release link is at "A" position. If you attach the Mono color cam as the Forced develop release link is at "B" position, the Mono color cam may be damaged.

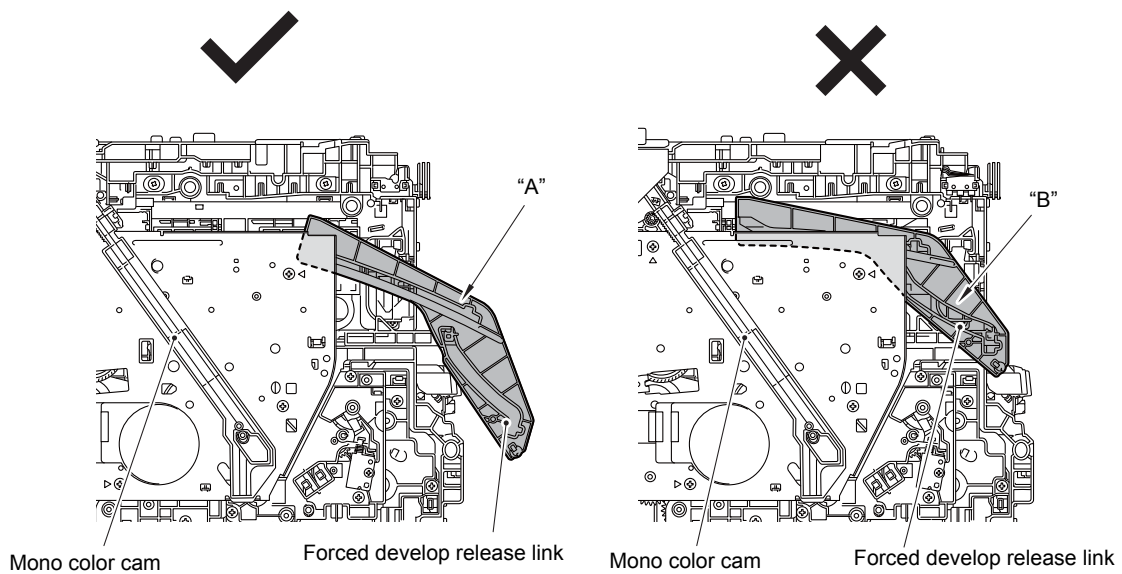

Fig. 3-203

- (9) Release all the wiring from the Cable rack.
- (10) Release the six Hooks and slide the Cable rack in the direction of the arrow and remove it from the Main body.

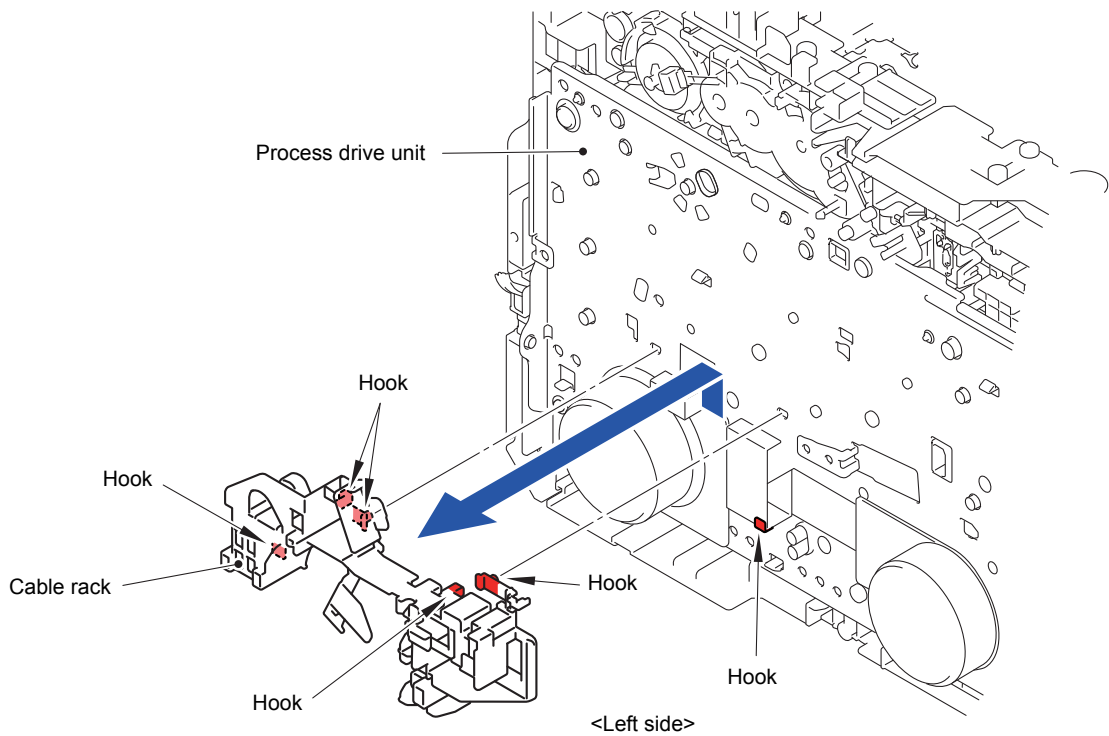

Fig. 3-204

- (11) Remove the Taptite cup S M3x8 SR screw and fasten the Under bar ground spring to the Rib of the Main body.

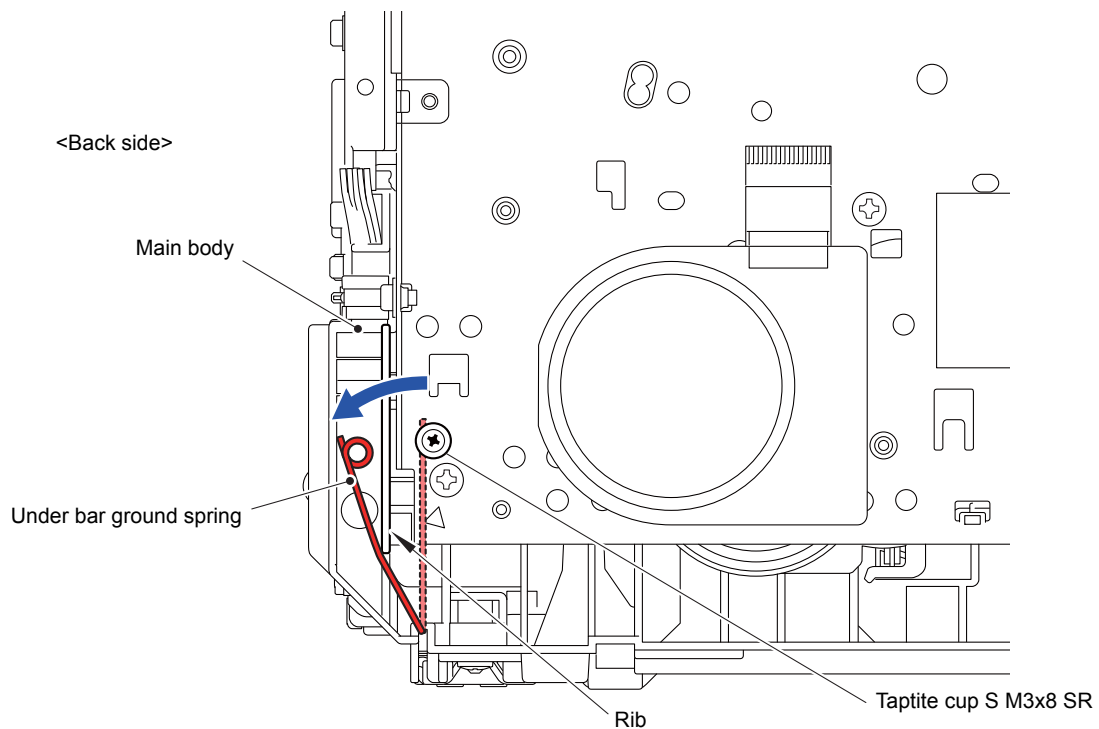

Fig. 3-205

(12) Remove the five Taptite bind B M4x12 screws, one Taptite pan (washer) B M4x12 DA screw, and the one Screw pan (S/P washer) M3.5x6 screw from the Process drive unit. Release the two Hooks and remove the Process drive unit from the Main body.

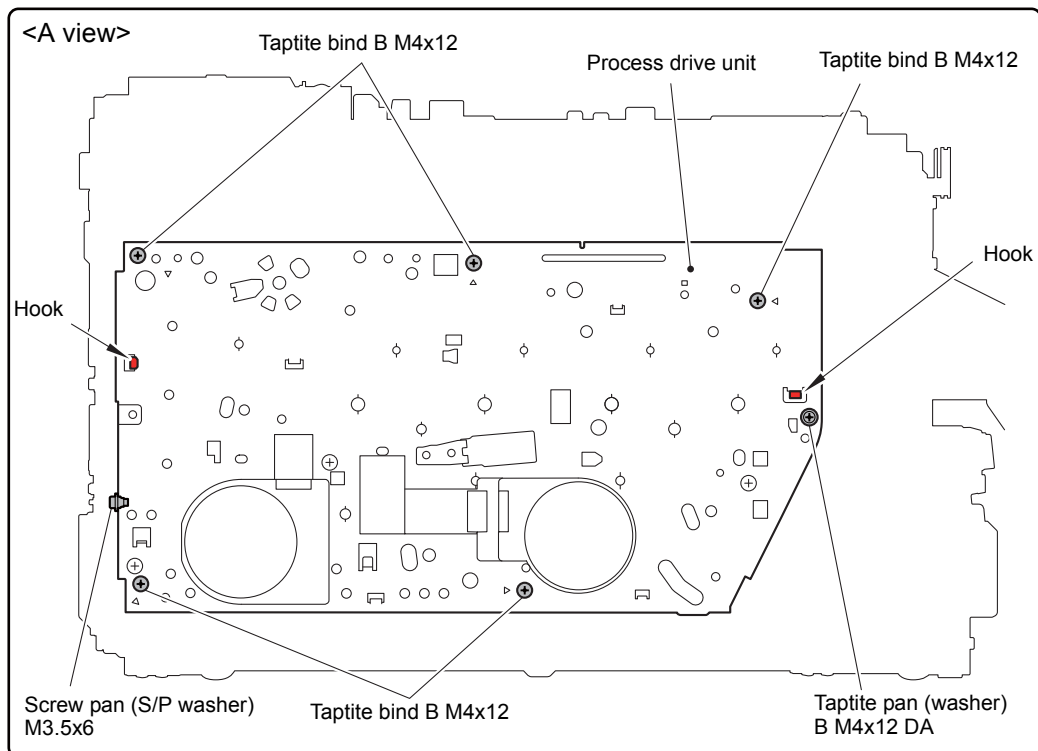
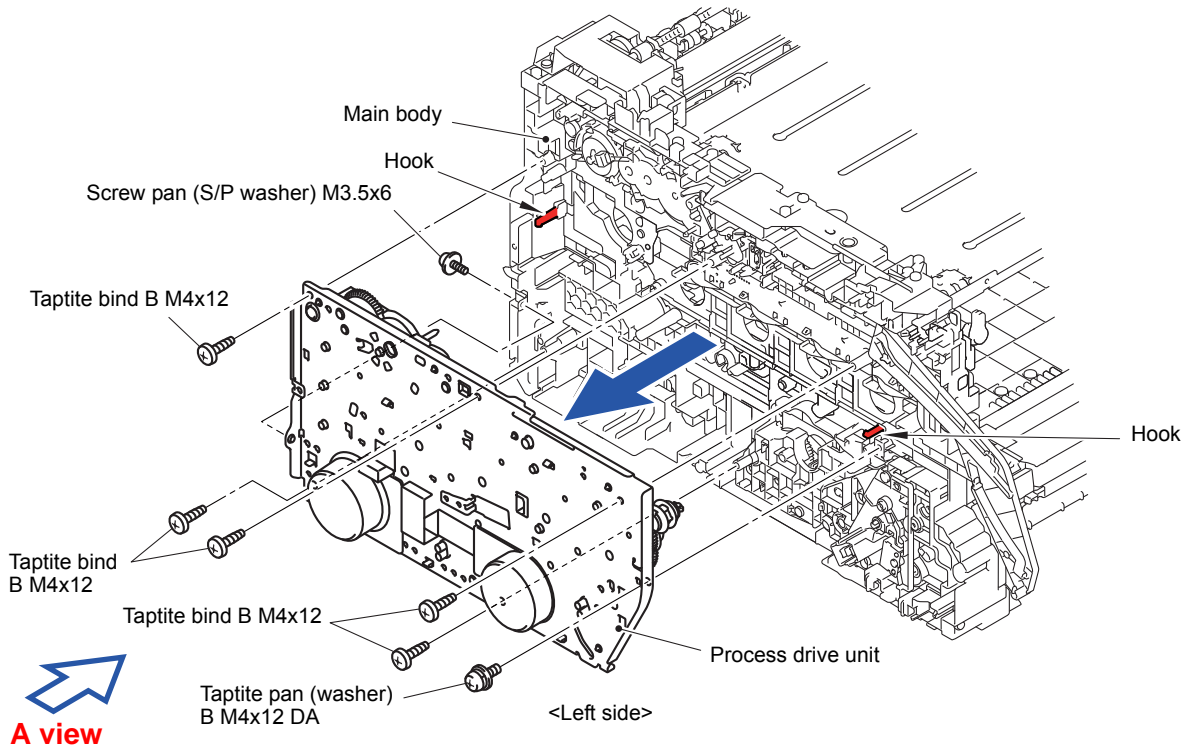

Fig. 3-206

(13) Release the Hook and remove the Fuser drive gear Z25 from the Process drive unit.

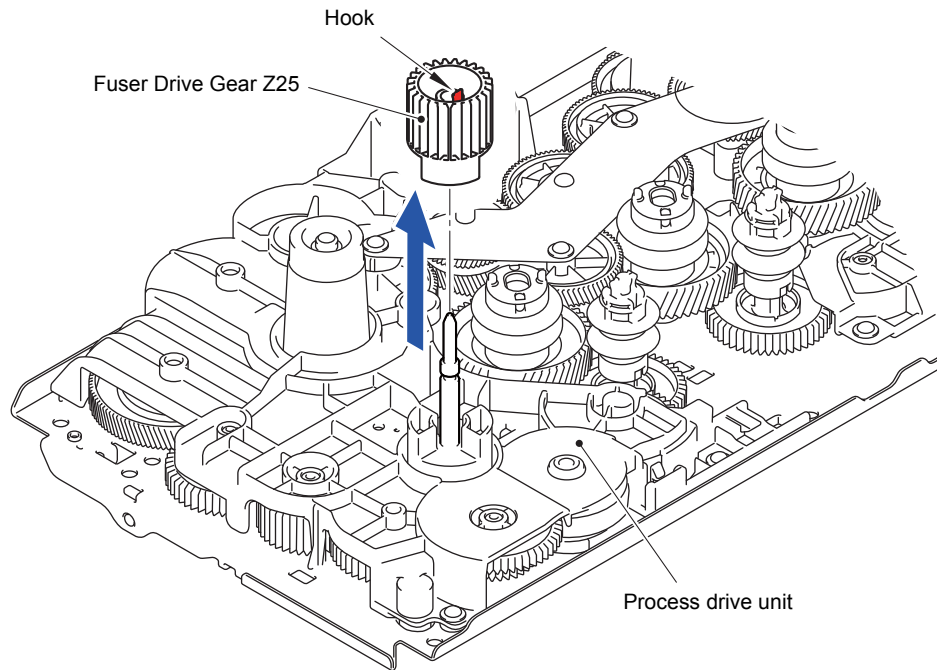

Fig. 3-207

Harness routing: Refer to “ **1** Laser Unit”, “ **2** Process Drive Unit, Front Cover Sensor, Main Drive Unit”, “ **3** Develop Release Drive Unit, Develop Release Sensor PCB ASSY, Toner/New Sensor PCB ASSY”, “ **10** MP Paper Empty/Registration Front Sensor PCB ASSY”, “ **11** Paper Feed Unit”

9.50 Main Drive Unit

- (1) Release all the wiring from the Main drive unit.
- (2) Remove the four Taptite bind B M4x12 screws from the Main drive unit. Release the Hook and remove the Main drive unit from the Main body.

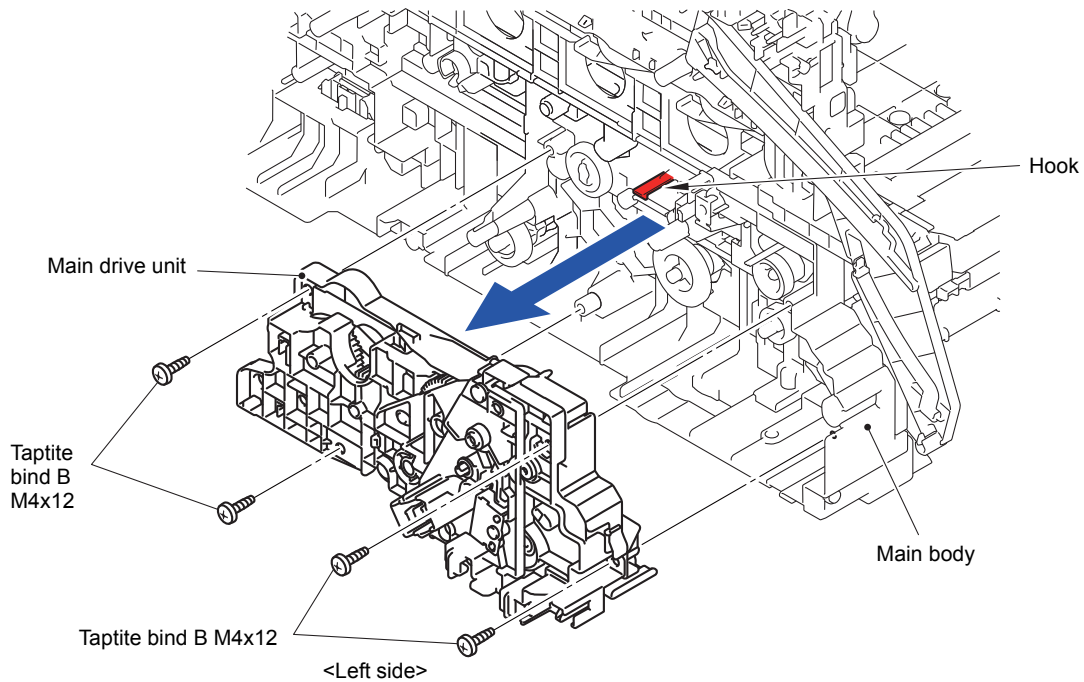

Fig. 3-208

Note:

As the DX drive gear Z15-23, Cleaner drive gear Z30, Registration gear Z26-23, PF drive gear 21, PF drive joint, Pinch roller drive gear Z21M05, Registration roller drive joint, and PP gear 14 55 tend to come off, be careful not to lose them.

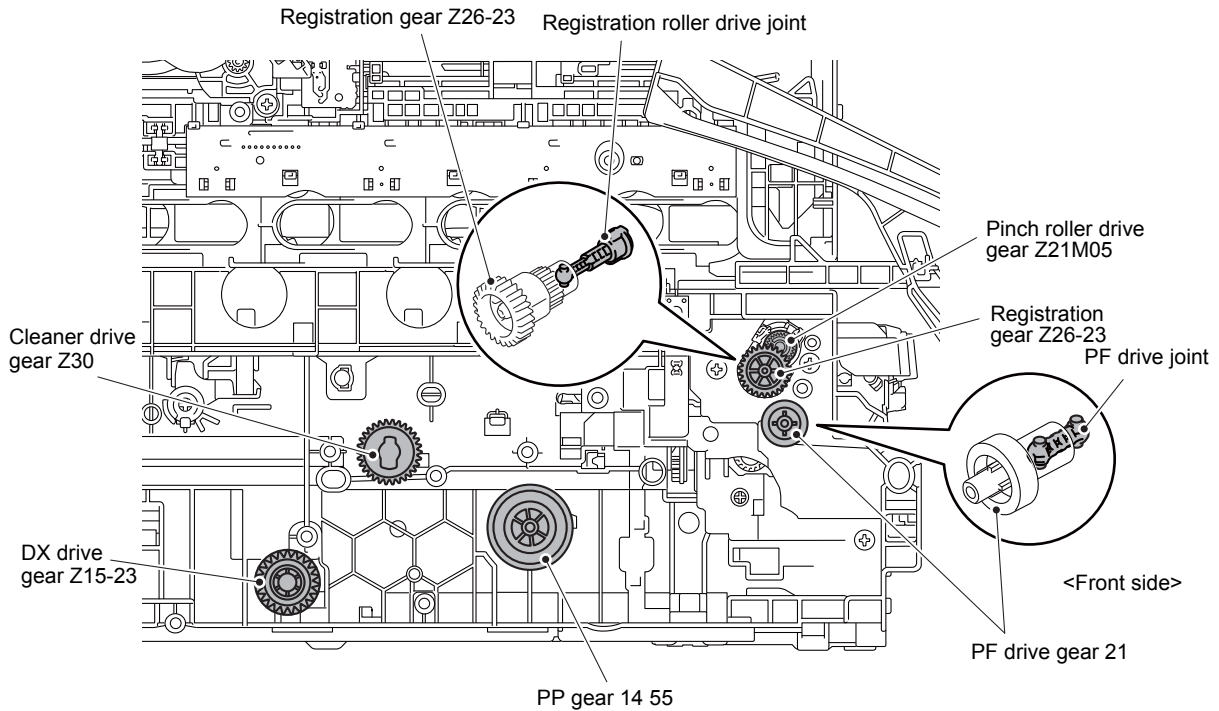

Fig. 3-209

Harness routing: Refer to “ [2 Process Drive Unit, Front Cover Sensor, Main Drive Unit](#)”

9.51 Develop Release Drive Unit

- (1) Release the wiring of the Develop release drive unit.
- (2) Remove the three Taptite bind B M4x12 screws from the Develop release drive unit. Release the three Hooks and remove the Develop release drive unit from the Main body.

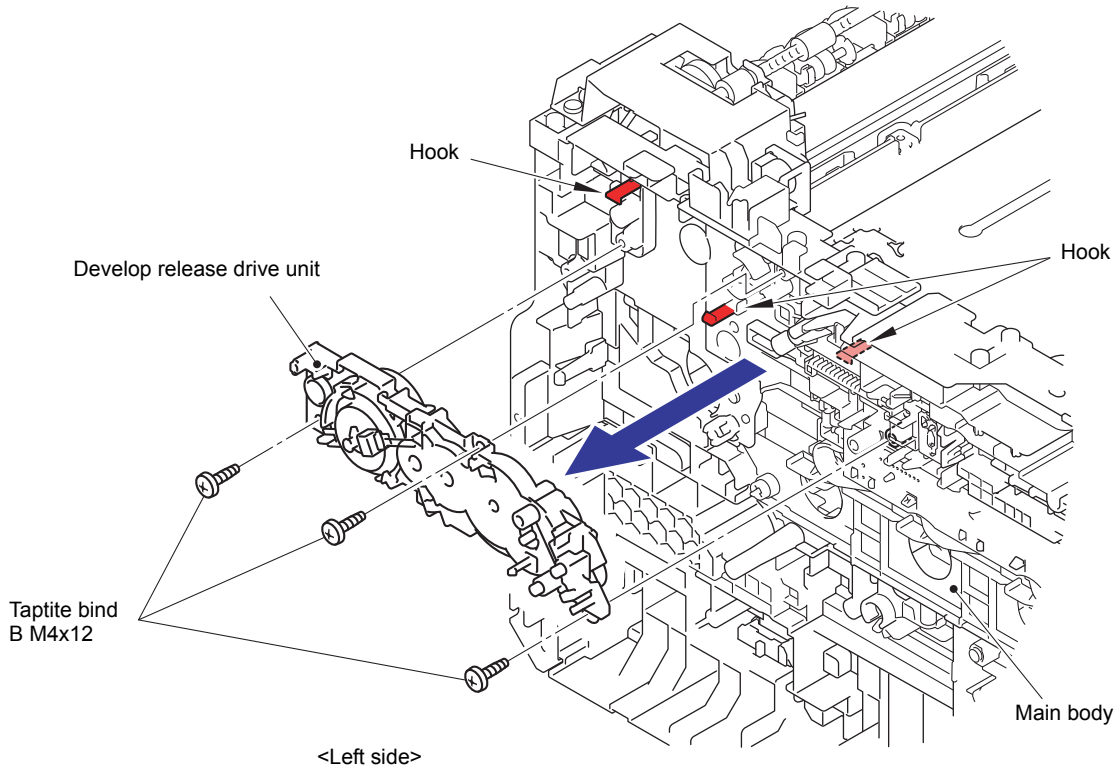

Fig. 3-210

Harness routing: Refer to “[3 Develop Release Drive Unit, Develop Release Sensor PCB ASSY, Toner/New Sensor PCB ASSY](#)”

9.52 Develop Release Sensor PCB ASSY

(1) Release the Hook and remove the Develop release sensor PCB ASSY from the Main body.

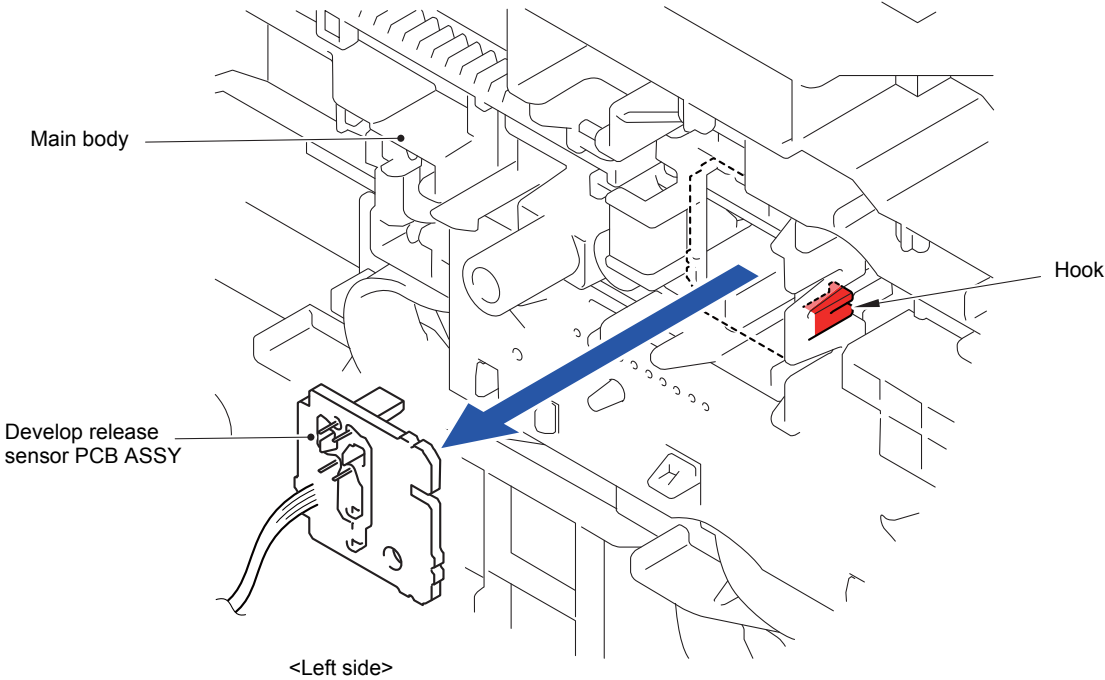

Fig. 3-211

9.53 Toner/New Sensor PCB ASSY

(1) Release the two Hooks and remove the Forced develop release link from the Main body.

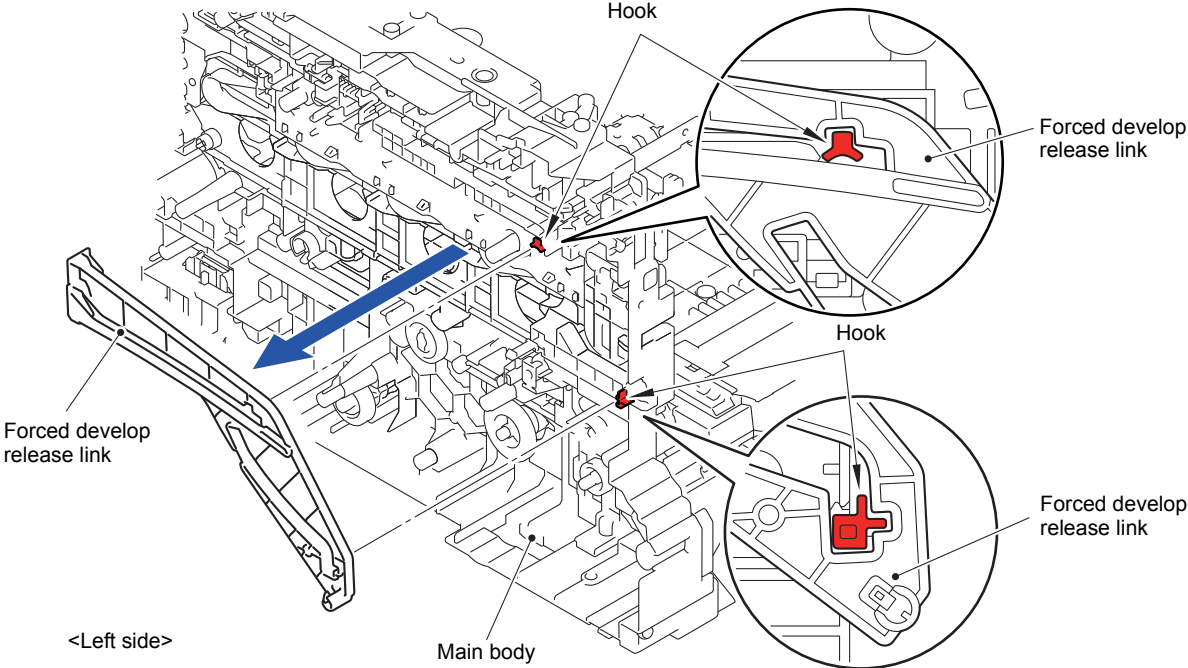

Fig. 3-212

(2) Release the six Hooks and remove the Toner/new sensor PCB ASSY from the Main body.

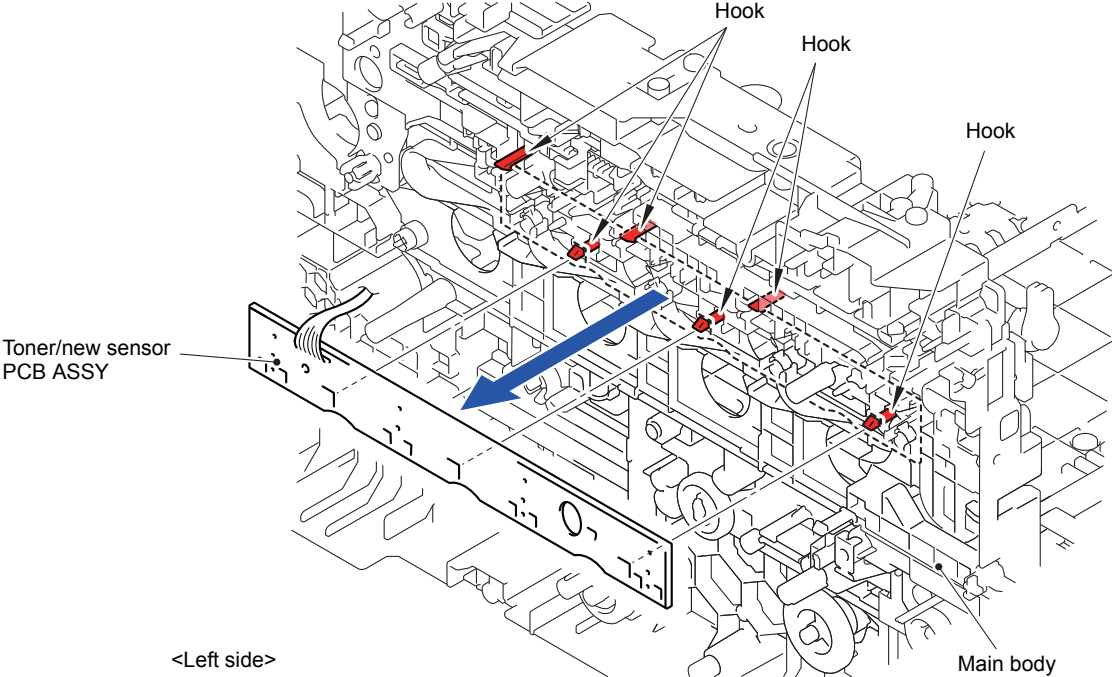

Fig. 3-213

9.54 Fuser Fan

- (1) Disconnect the Connector (CN4) from the High-voltage power supply PCB ASSY.

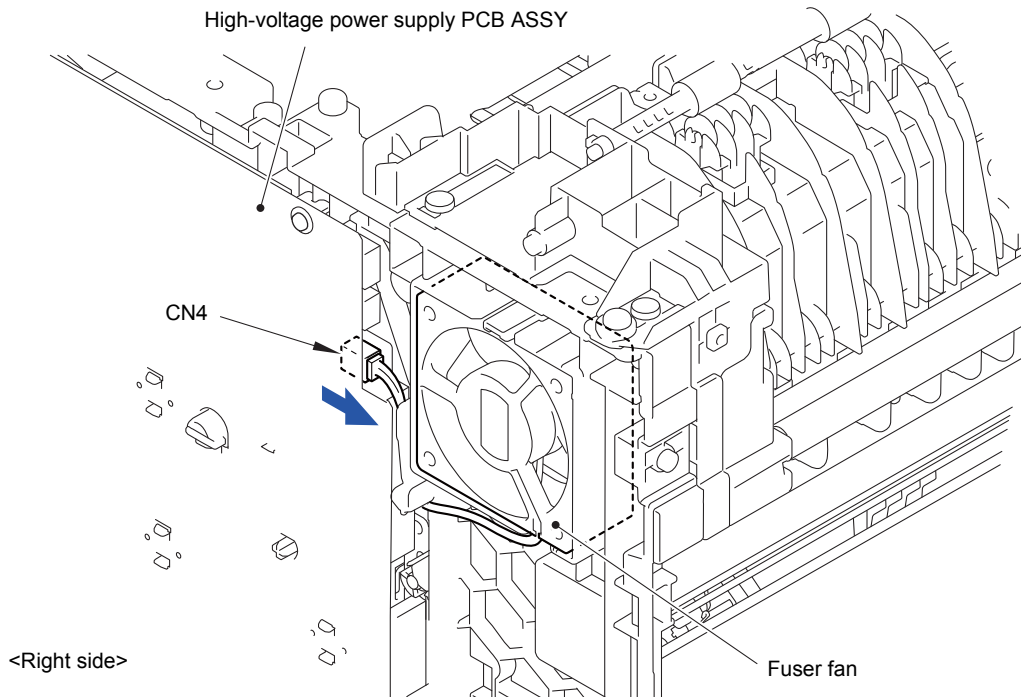

Fig. 3-214

- (2) Slightly rotate the Fuser fan in the direction of the arrow 2a and pull it out from the Main body.

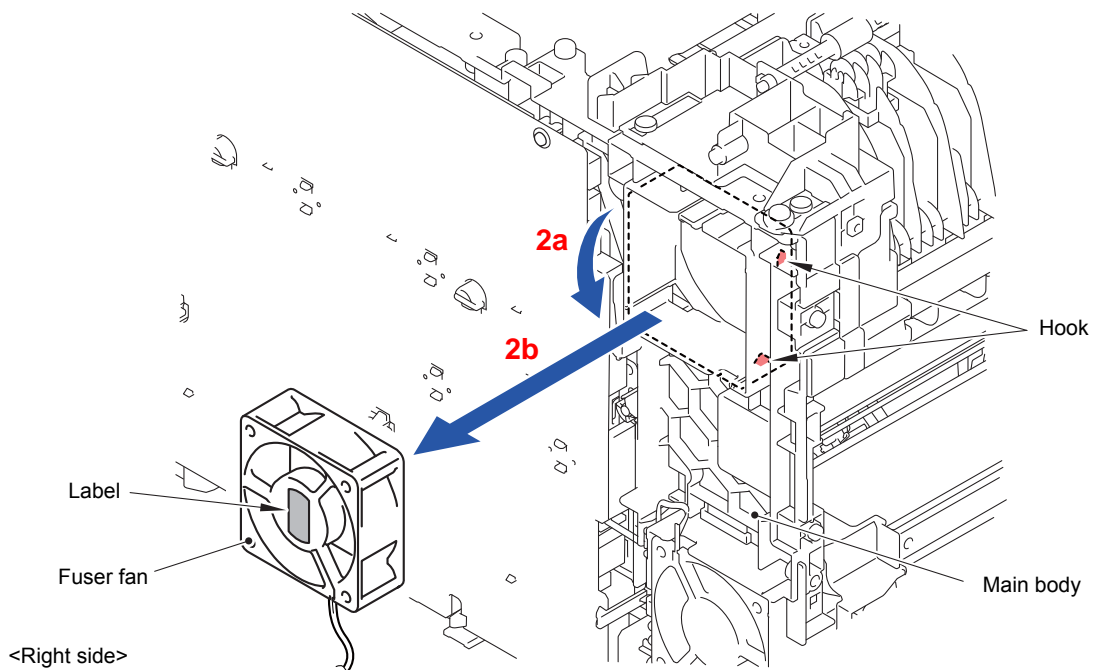

Fig. 3-215

Assembling Note:

When assembling the Fuser fan, be sure to assemble it in a way that the label side faces out.

Harness routing: Refer to “[8 Fuser Fan, Power Fan](#)”

9.55 Paper Eject ASSY

- (1) Disconnect the two Connectors (CN1 and CN2) from the High-voltage power supply PCB ASSY.
- (2) Release the wiring of the High-voltage main harness ASSY.

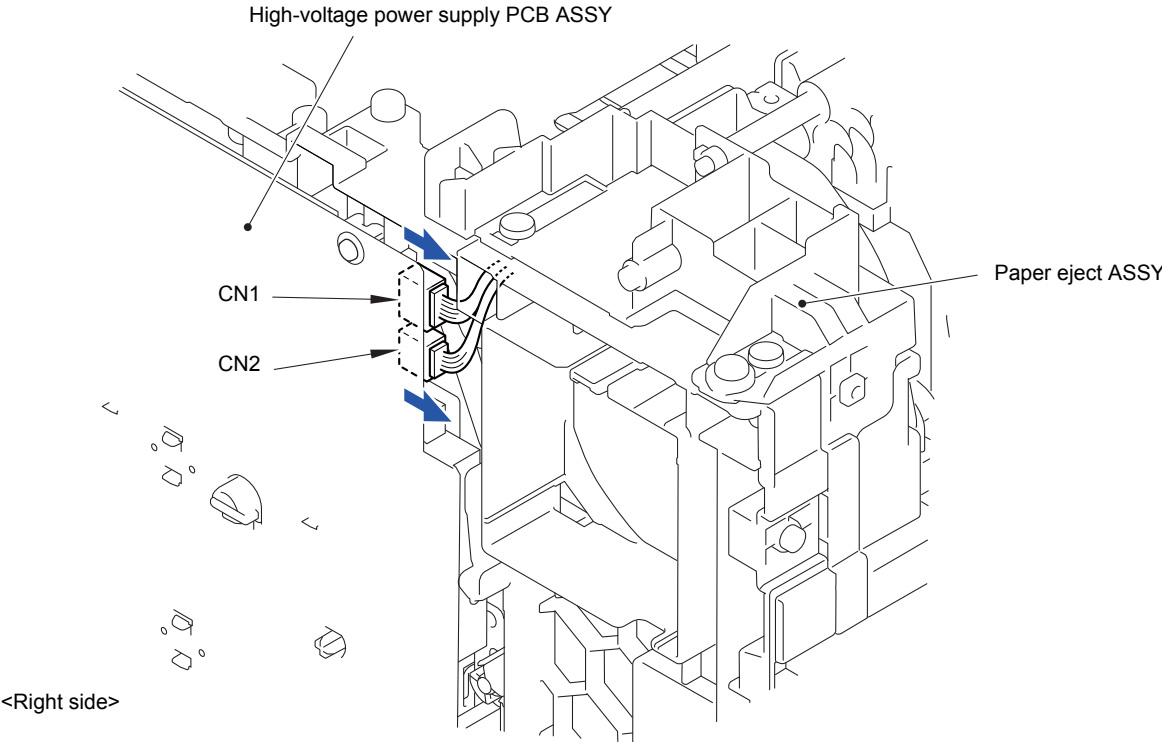

Fig. 3-216

- (3) Remove the four Taptite bind B M4x12 screws and remove the Paper eject ASSY from the Main body.

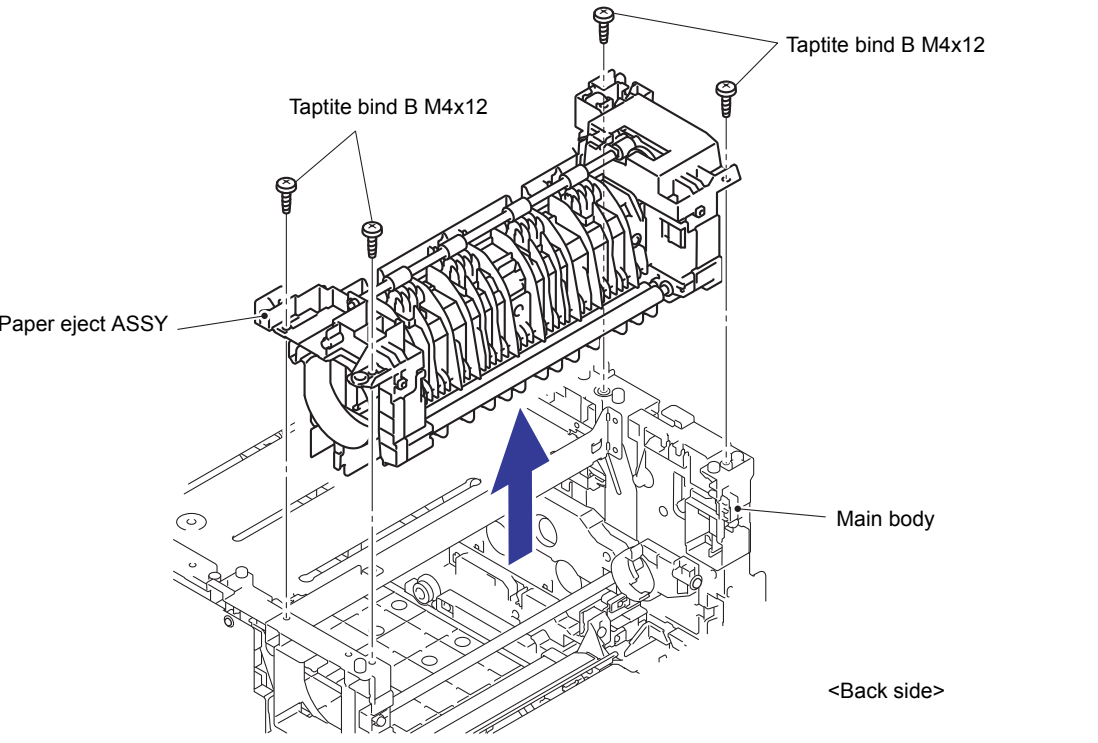

Fig. 3-217

Harness routing: Refer to " 4 Paper Eject ASSY"

9.56 Toner Filter ASSY

(1) Release the five Hooks and remove the Toner filter ASSY from the Paper eject ASSY.

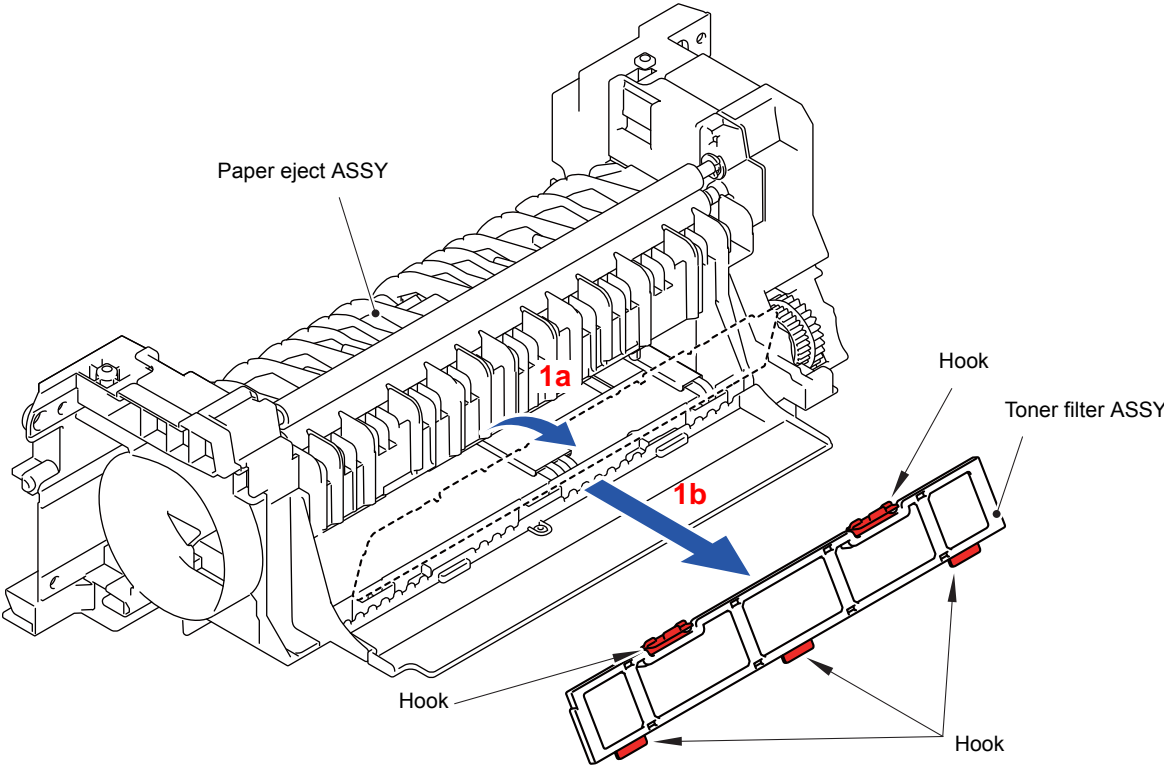

Fig. 3-218

9.57 Paper Eject Origin Sensor

- (1) Remove the Eject ground wire 1 from the Paper eject ASSY.

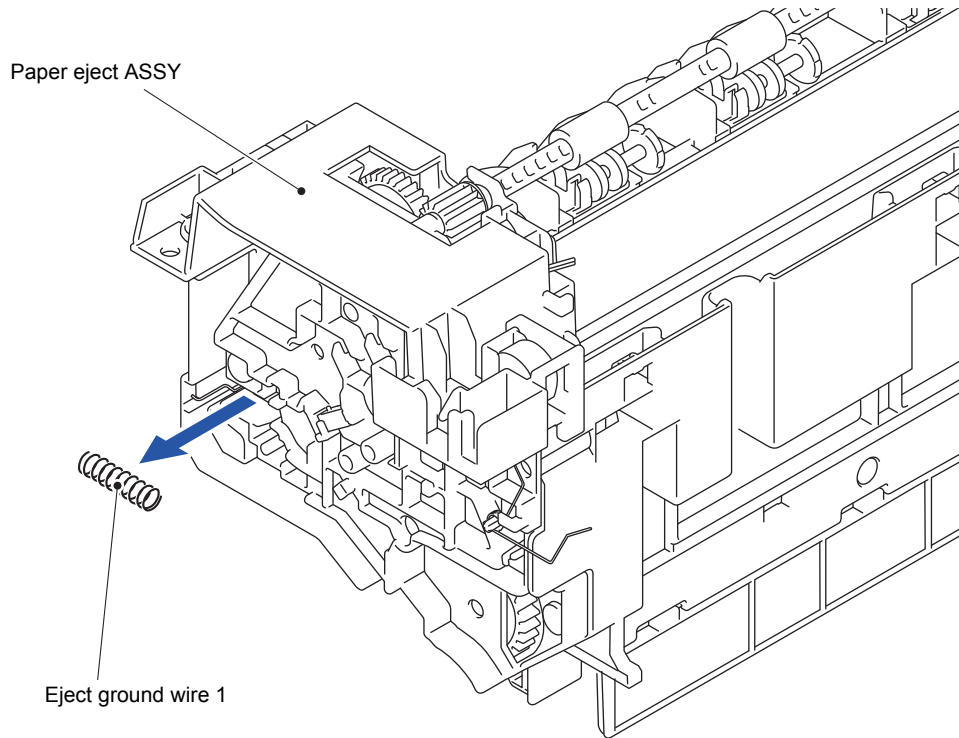

Fig. 3-219

- (2) Release the five Hooks and remove the Eject ground wire 2 from the Paper eject ASSY.

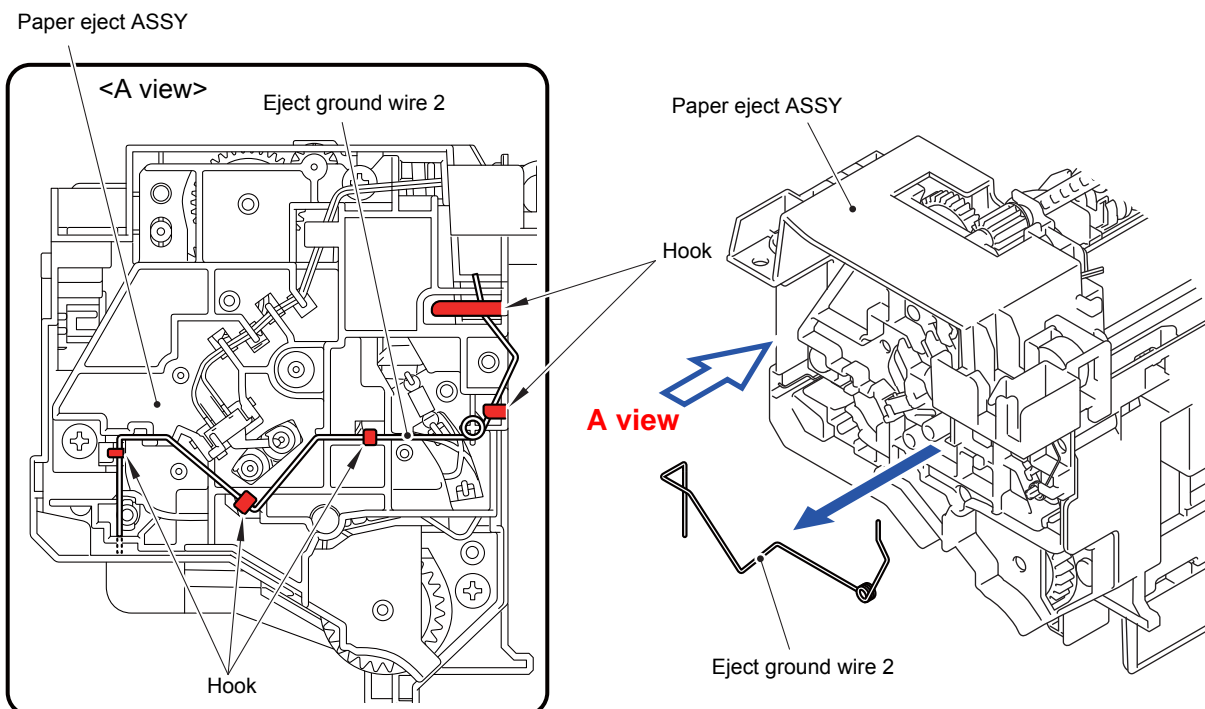

Fig. 3-220

Assembling Note:

After assembling the Eject ground wire 1 and Eject ground wire 2, check the conduction between the Middle roller shaft and the Cooling roller shaft.

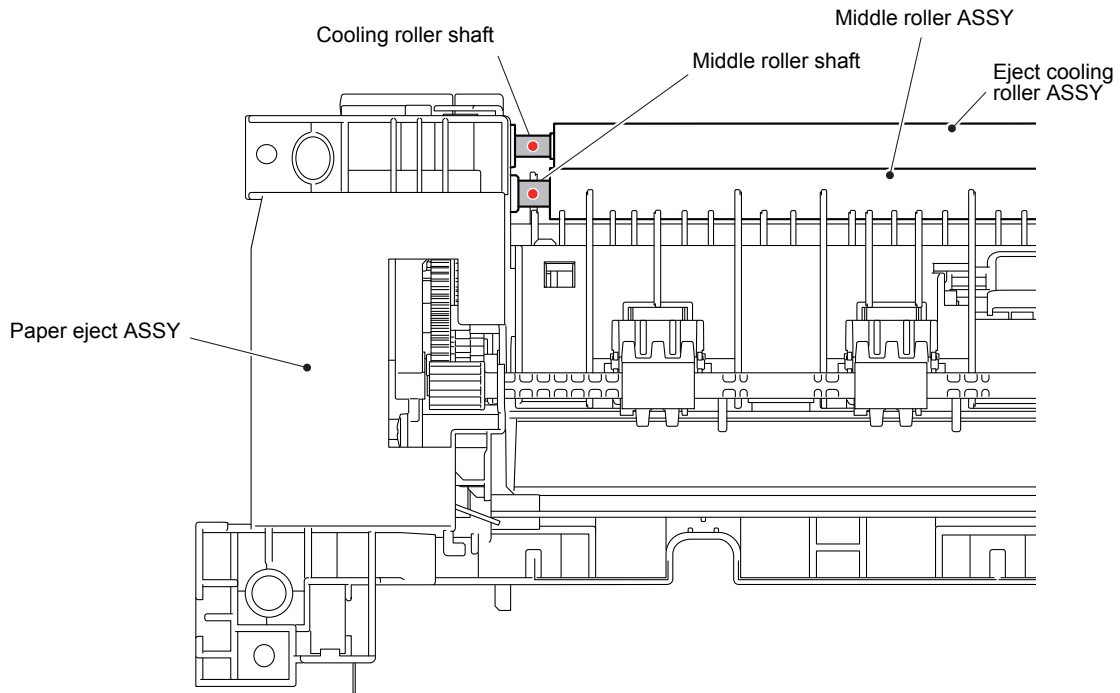

Fig. 3-221

- (3) Release the wiring of the Paper eject origin sensor.
- (4) Release the two Hooks and remove the Paper eject origin sensor from the Paper eject ASSY.

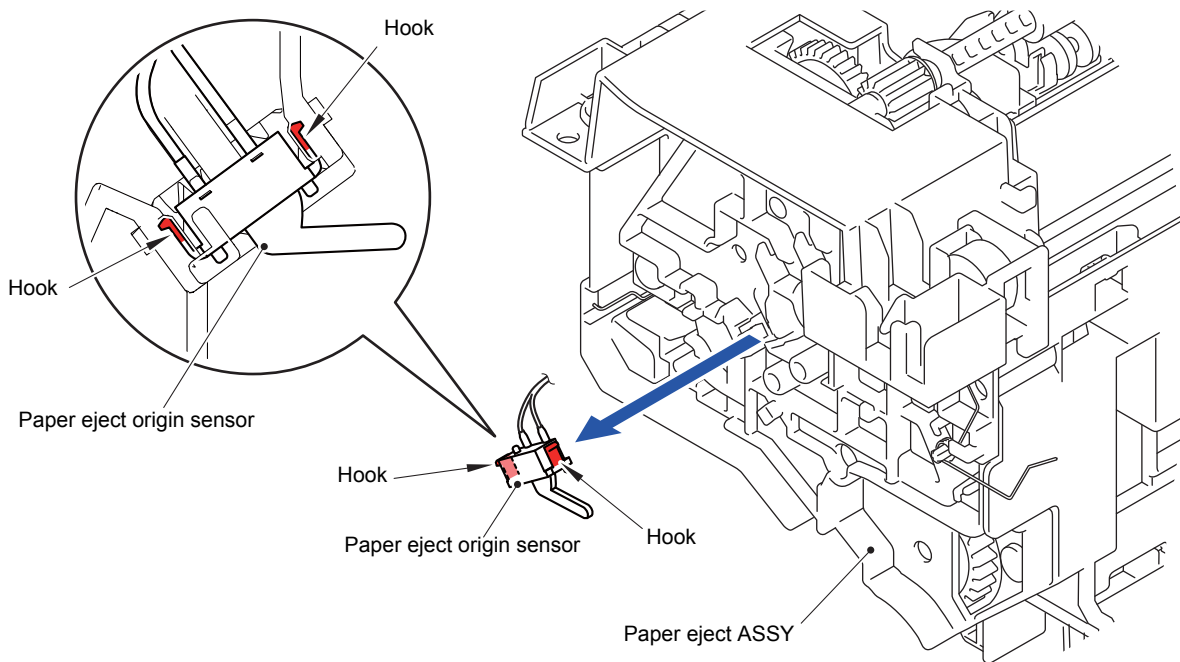

Fig. 3-222

Harness routing: Refer to “**4 Paper Eject ASSY**”

9.58 Back Cover Sensor ASSY

- (1) Release the wiring of the Back cover sensor ASSY.
- (2) Release the two Hooks and remove the Back cover sensor ASSY from the Main body.

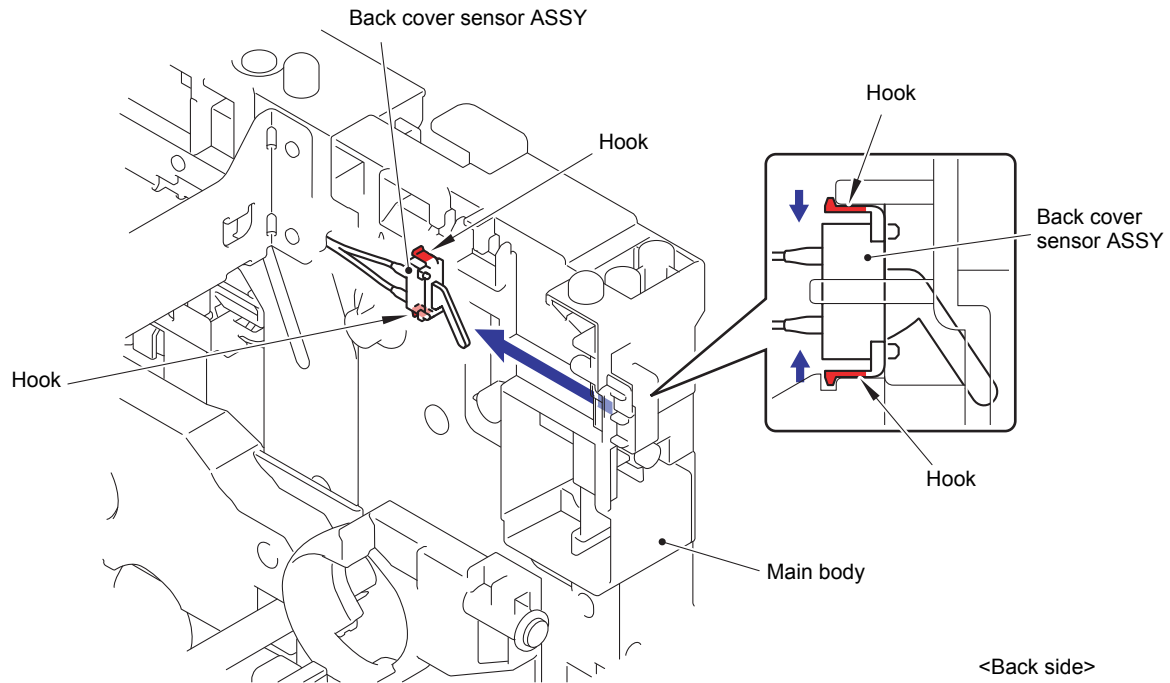

Fig. 3-223

Harness routing: Refer to “[5 Back Cover Sensor ASSY](#)”

9.59 Eject Sensor PCB ASSY

- (1) Release the wiring of the Eject sensor PCB ASSY.
- (2) Release the Hook and remove the Eject sensor PCB ASSY from the Main body.

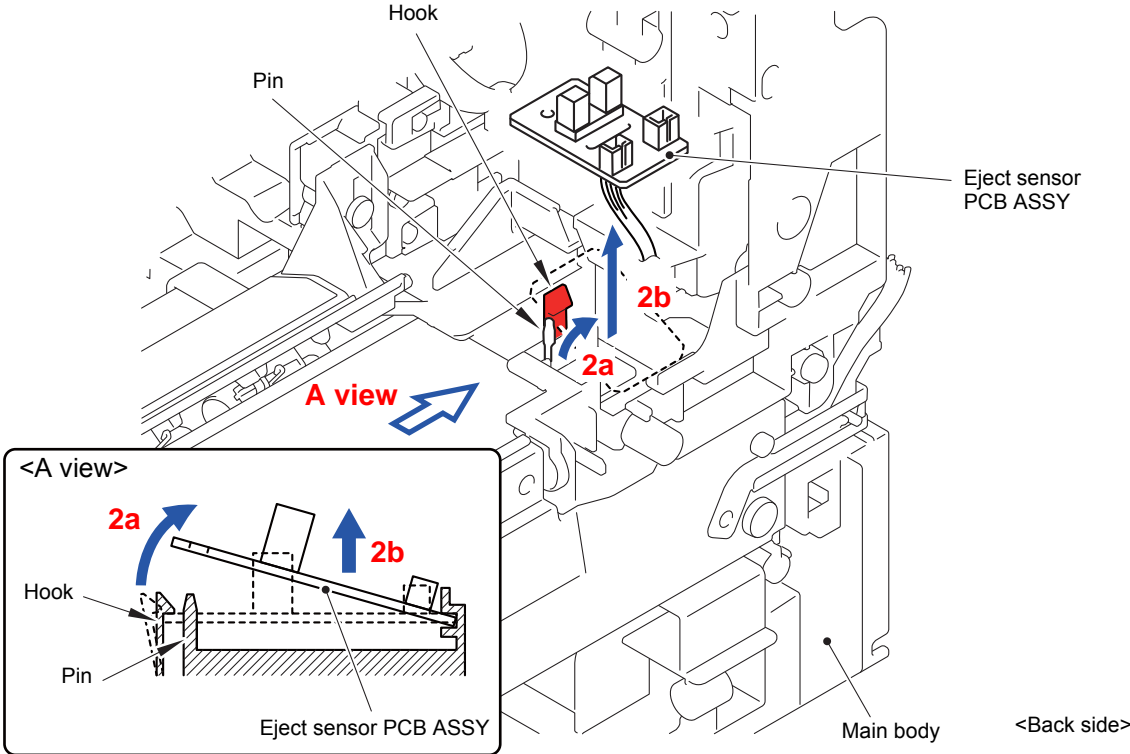

Fig. 3-224

Harness routing: Refer to “ 6 Eject Sensor PCB ASSY, Fuser Unit”

9.60 Registration Mark Sensor Unit

- (1) Release the wiring of the Registration mark sensor unit.
- (2) Remove the two Taptite bind B M3x10 screws from the Registration mark sensor unit. Release the two Bosses and remove the Registration mark sensor unit from the Main body.

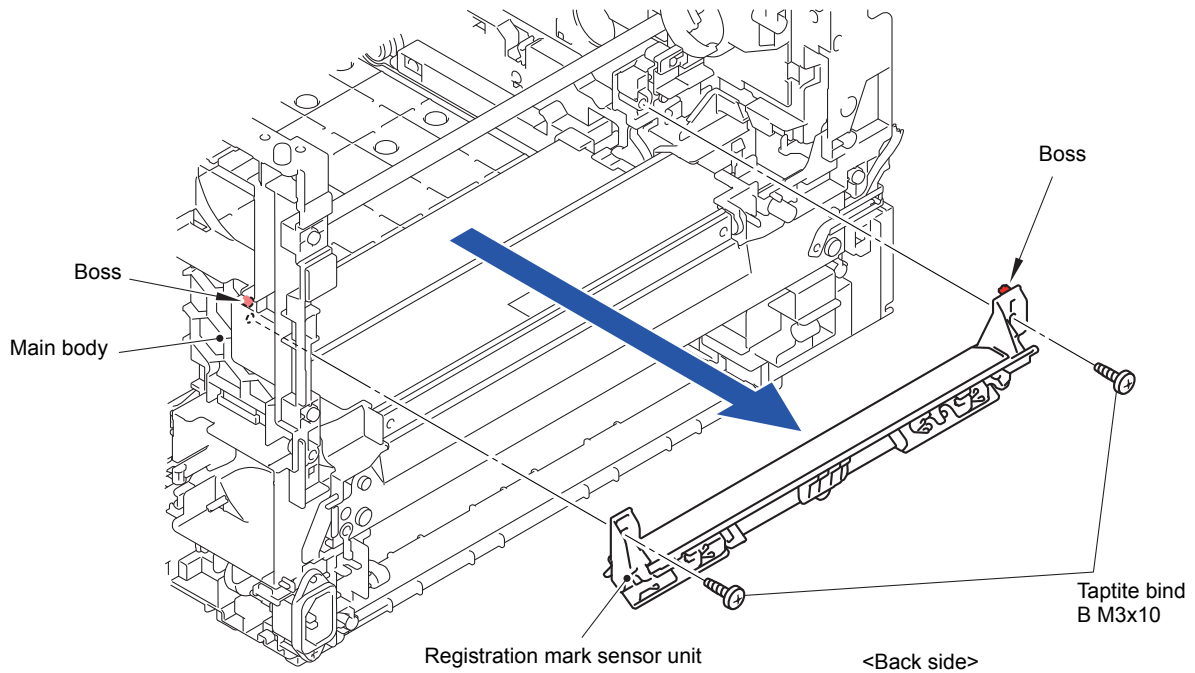

Fig. 3-225

Assembling Note:

- When attaching the Registration mark sensor unit, make sure that the Registration ground spring is placed as shown in the figure.
- After assembling the Registration mark sensor unit, make sure that the Front chute flapper moves.

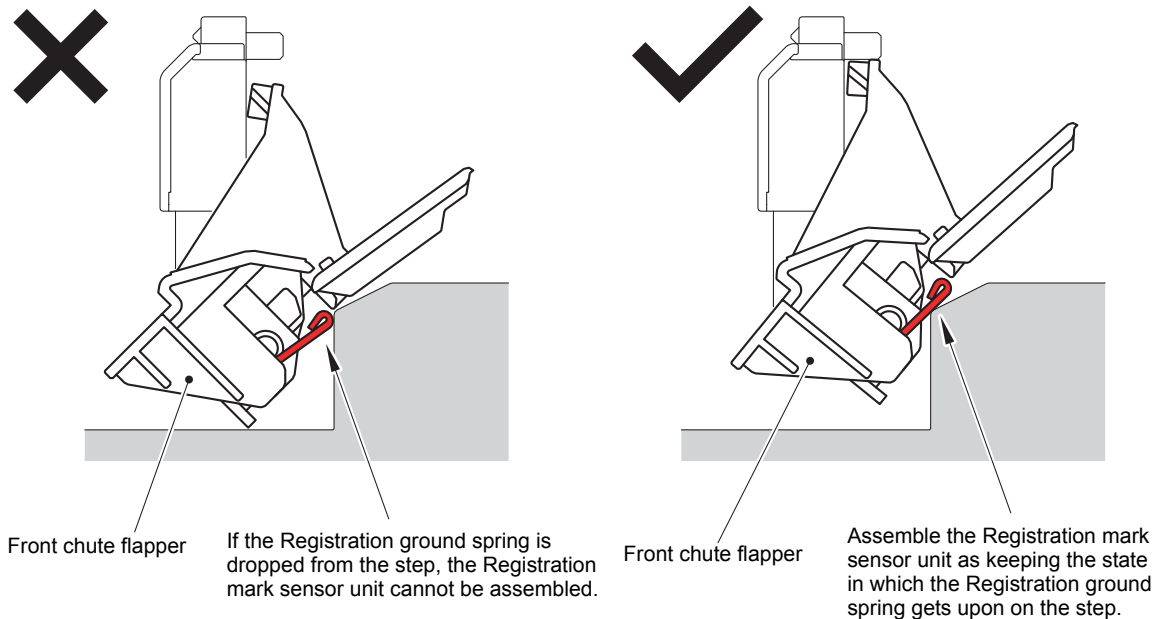

Fig. 3-226

Harness routing: Refer to “ **7** Registration Mark Sensor Unit”

9.61 Power Fan

- (1) Disconnect the Connector (CN5) from the High-voltage power supply PCB ASSY.

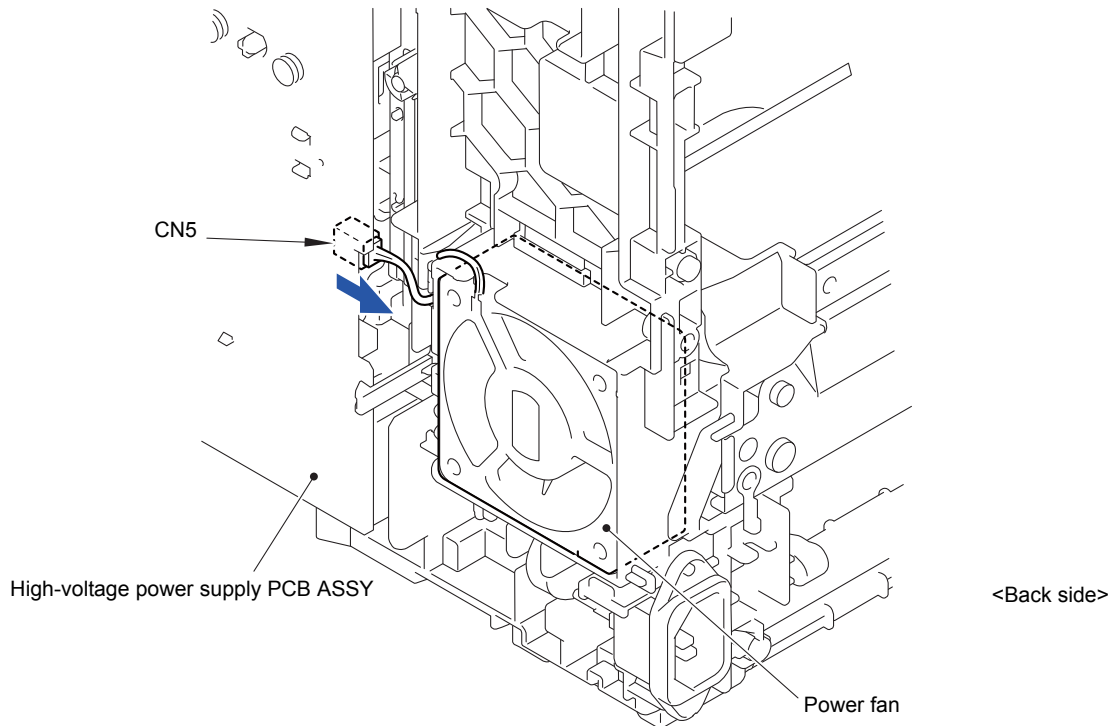

Fig. 3-227

- (2) Slightly rotate the Power fan in the direction of the arrow 2a and pull it out from the Main body.

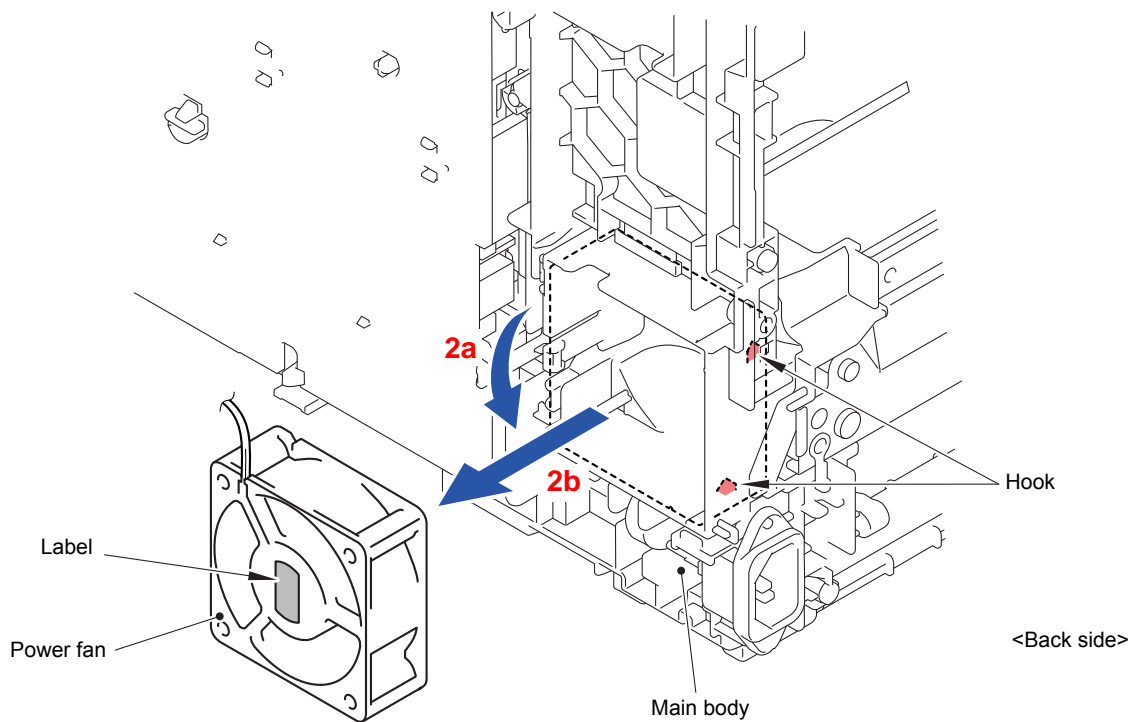

Fig. 3-228

Assembling Note:

When assembling the Power fan, be sure to assemble it in a way that the label side faces out.

Harness routing: Refer to “**8 Fuser Fan, Power Fan**”

9.62 Low-voltage Power Supply PCB Unit

- (1) Remove the Screw pan (S/P washer) M3.5x6 screw and remove the FG harness of the Inlet harness ASSY from the LVPS plate.
- (2) Remove the Taptite flat B M3x10 screw and remove the Inlet harness ASSY from the Main body.
- (3) Release the wiring of the Inlet harness ASSY.
- (4) Release the wiring of the LVPS-heater harness ASSY.

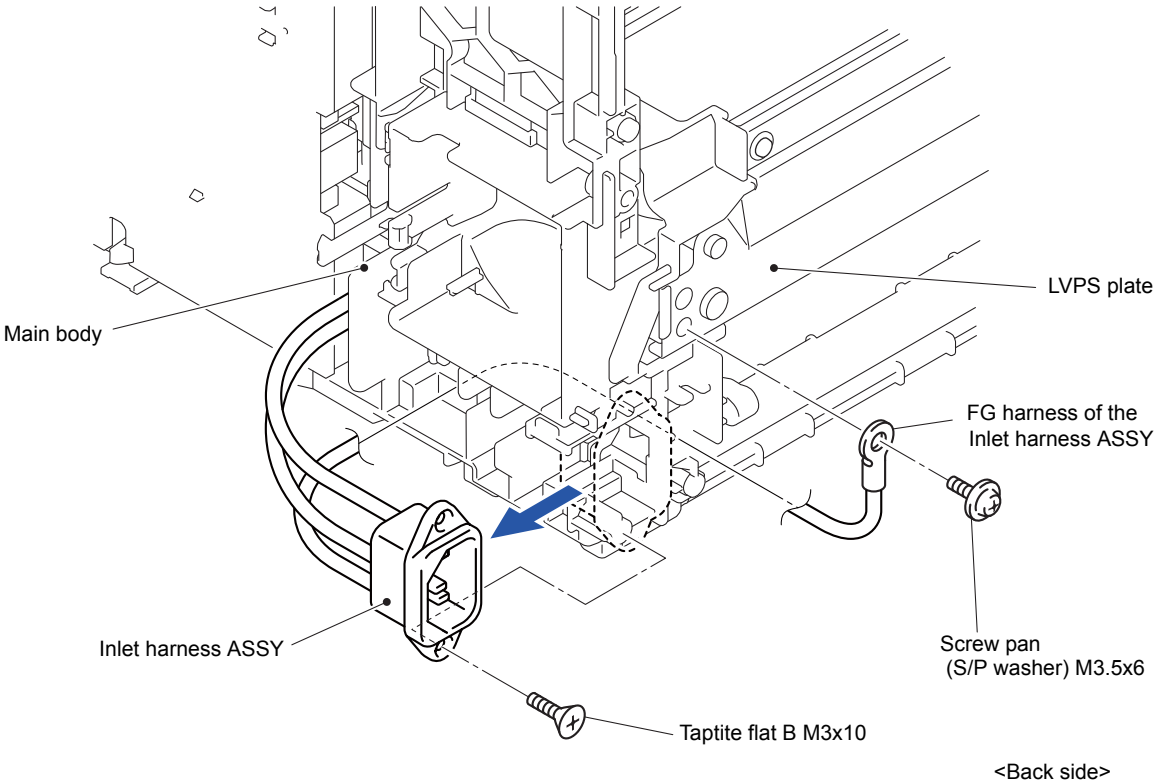

Fig. 3-229

- (5) Remove the Screw pan (S/P washer) M3.5x6 screw from the Drive ground plate.
- (6) Release the Boss and remove the Drive ground plate from the Low-voltage power supply PCB unit.
- (7) Release the wiring of the LVPS-main harness ASSY.

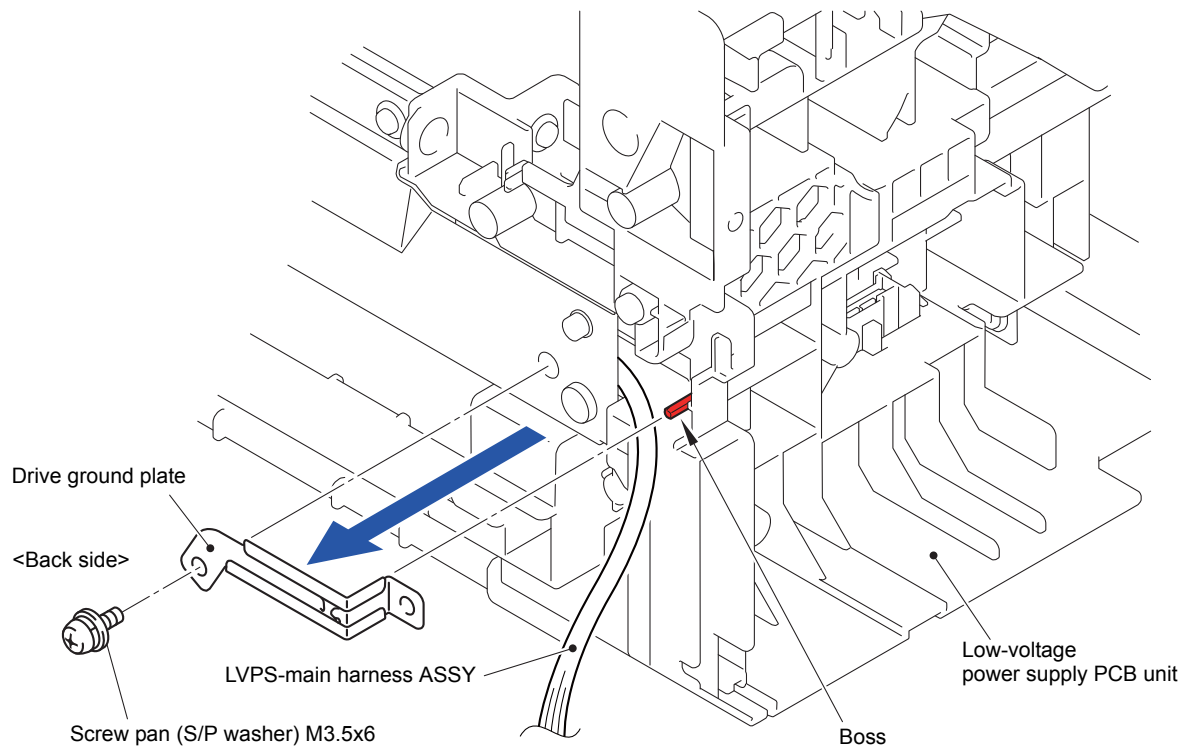

Fig. 3-230

- (8) Remove the two Taptite cup S M3x8 SR screws and two Taptite bind B M4x12 screws, and remove the LVPS plate from the Main body.

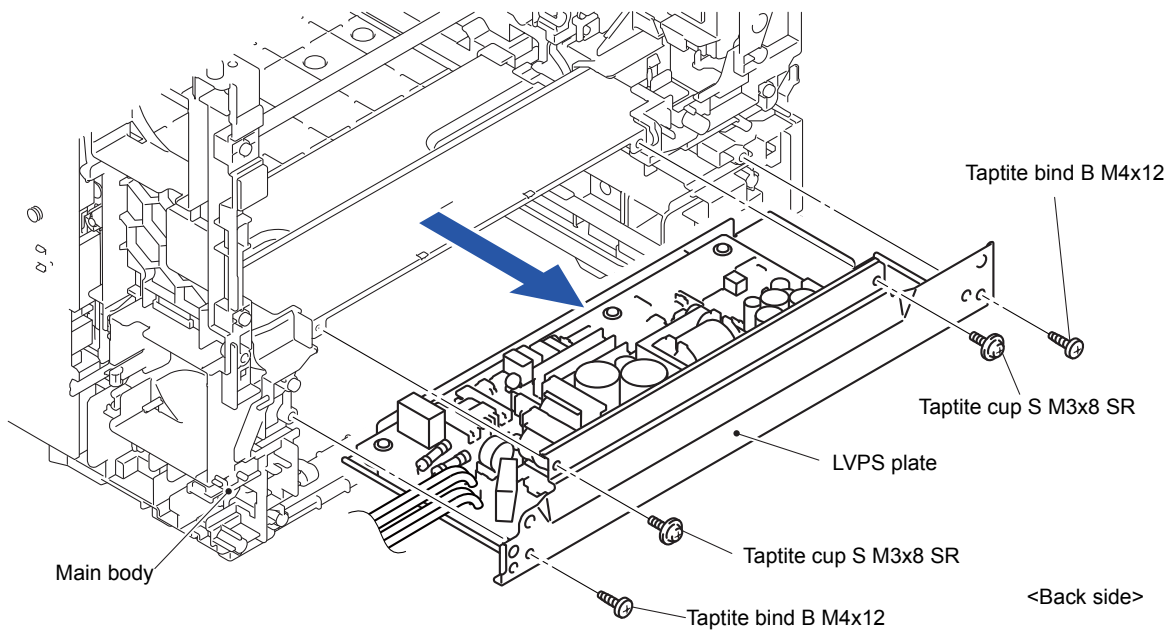

Fig. 3-231

- (9) Disconnect the Connector (CN101) of the LVPS-main harness ASSY from the Low-voltage power supply PCB unit.

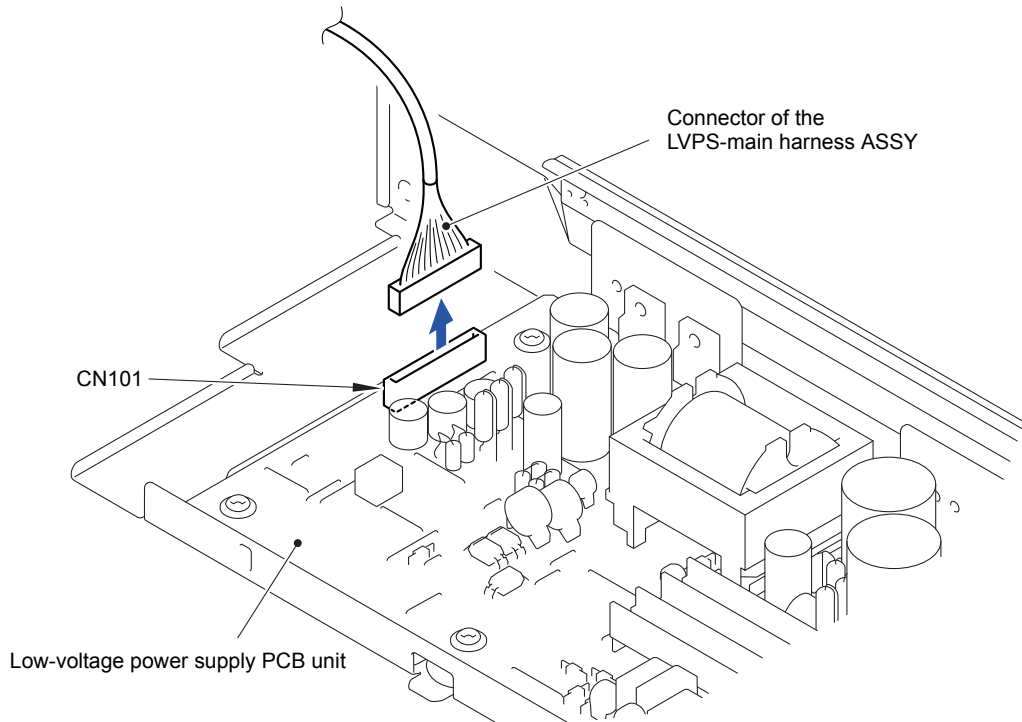

Fig. 3-232

- (10) Remove the five Taptite cup S M3x6 SR screws and remove the Low-voltage power supply PCB unit from the LVPS plate.

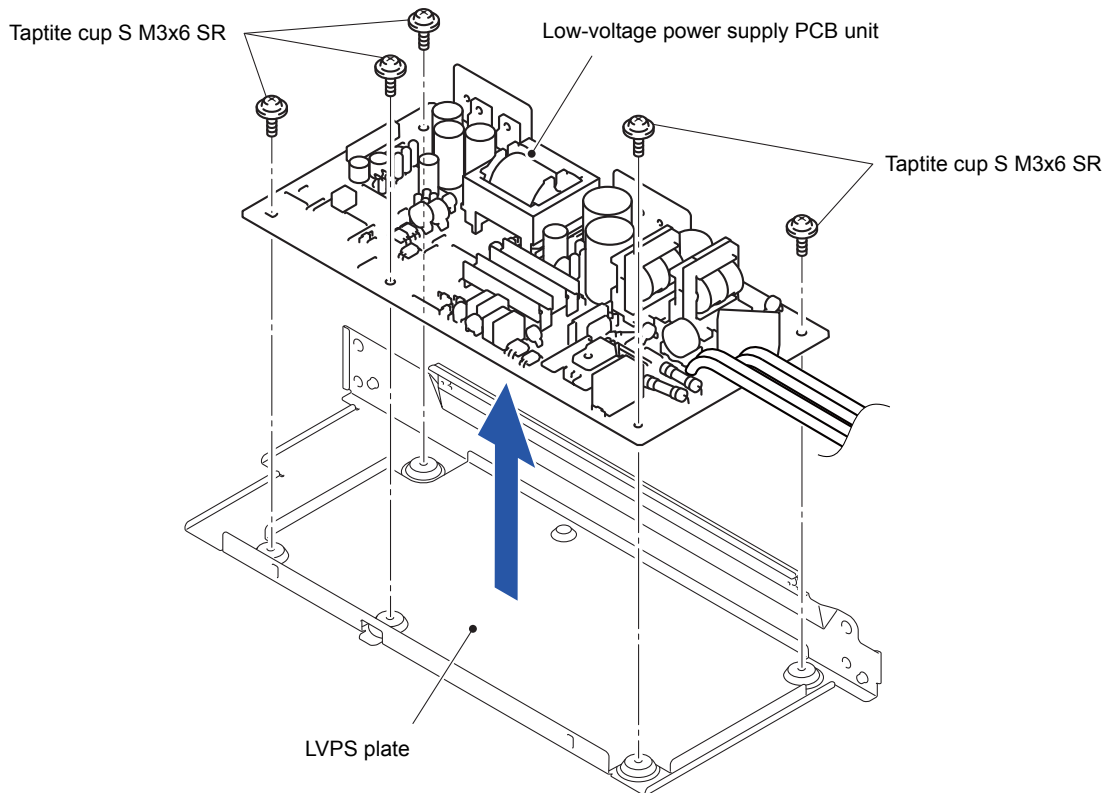

Fig. 3-233

Harness routing: Refer to “[9 Low-voltage Power Supply PCB Unit](#)”

9.63 MP Paper Empty Actuator A ASSY/ MP Paper Empty Actuator B

- (1) Press "A" to release the Hook and remove the MP upper frame cover from the MP upper cover ASSY.

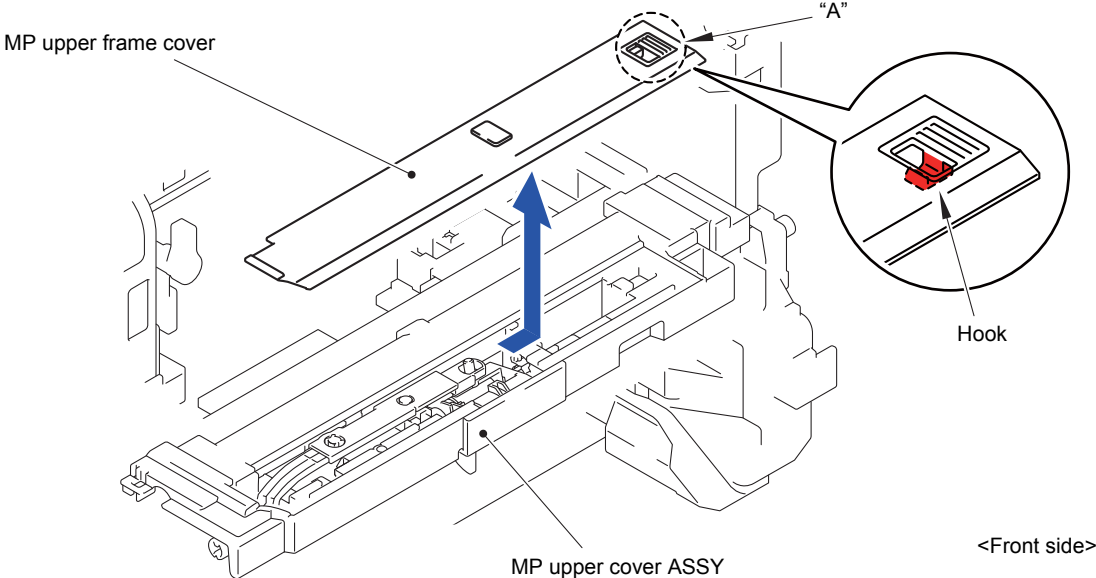

Fig. 3-234

- (2) Remove the MP lift arm B from the MP upper cover ASSY.

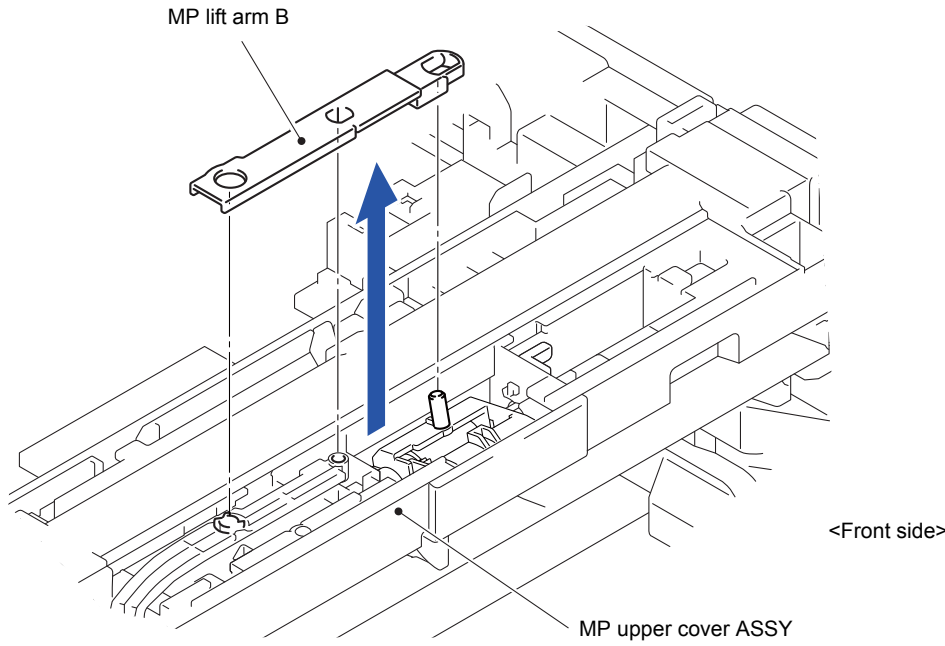

Fig. 3-235

- (3) Release the Hook 1 and rotate the MP holder bushing in the direction of the arrow.
- (4) Release the Hook 2 and remove the MP holder bushing from the MP upper cover ASSY.

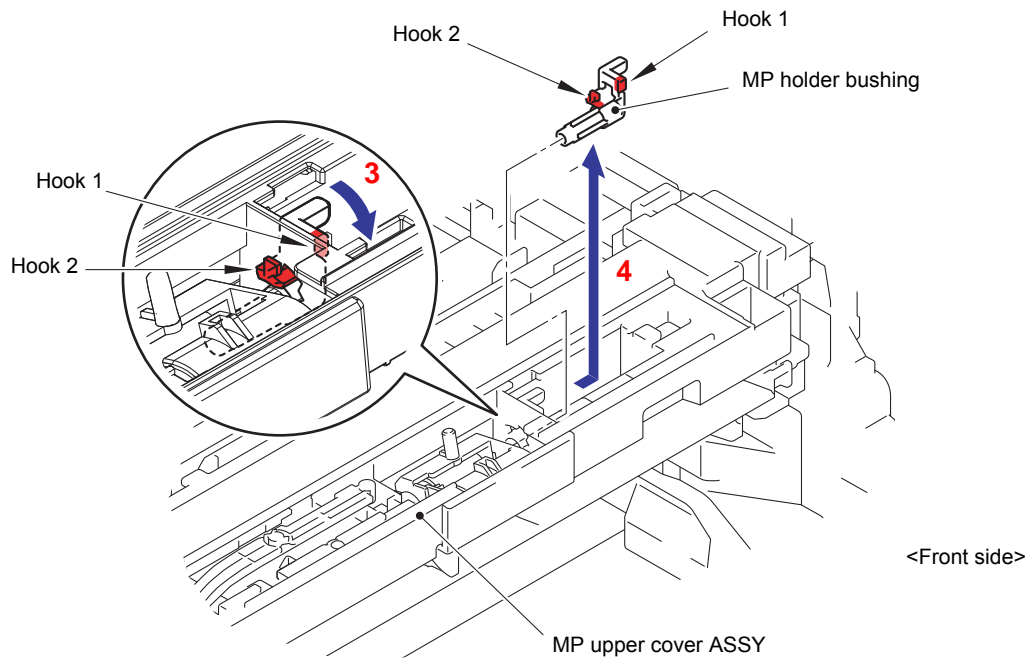

Fig. 3-236

- (5) Remove the MP roller holder ASSY from the MP upper cover ASSY.

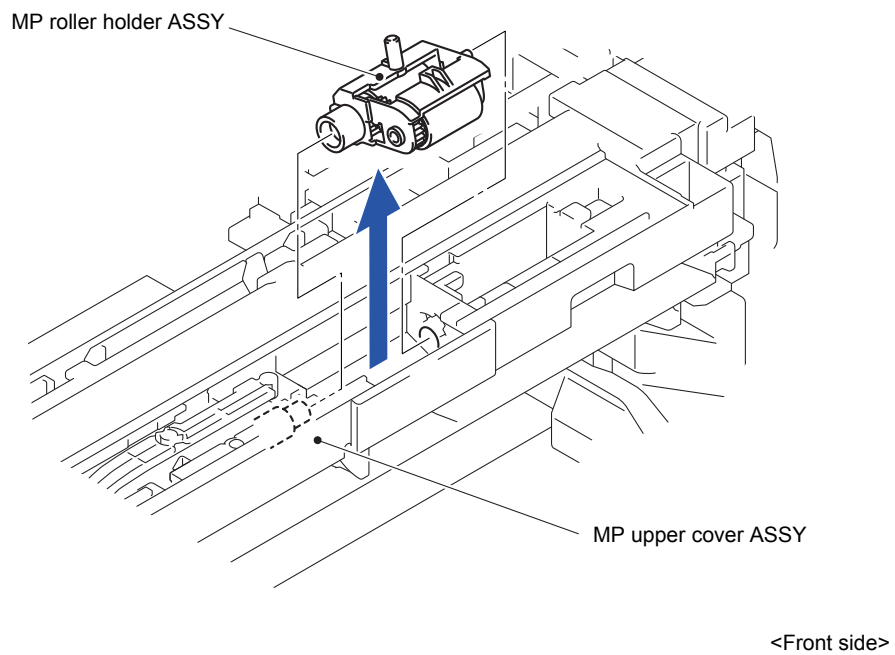

Fig. 3-237

(6) Remove the Registration gear Z26-23 from the Registration/pinch roller gear bushing.

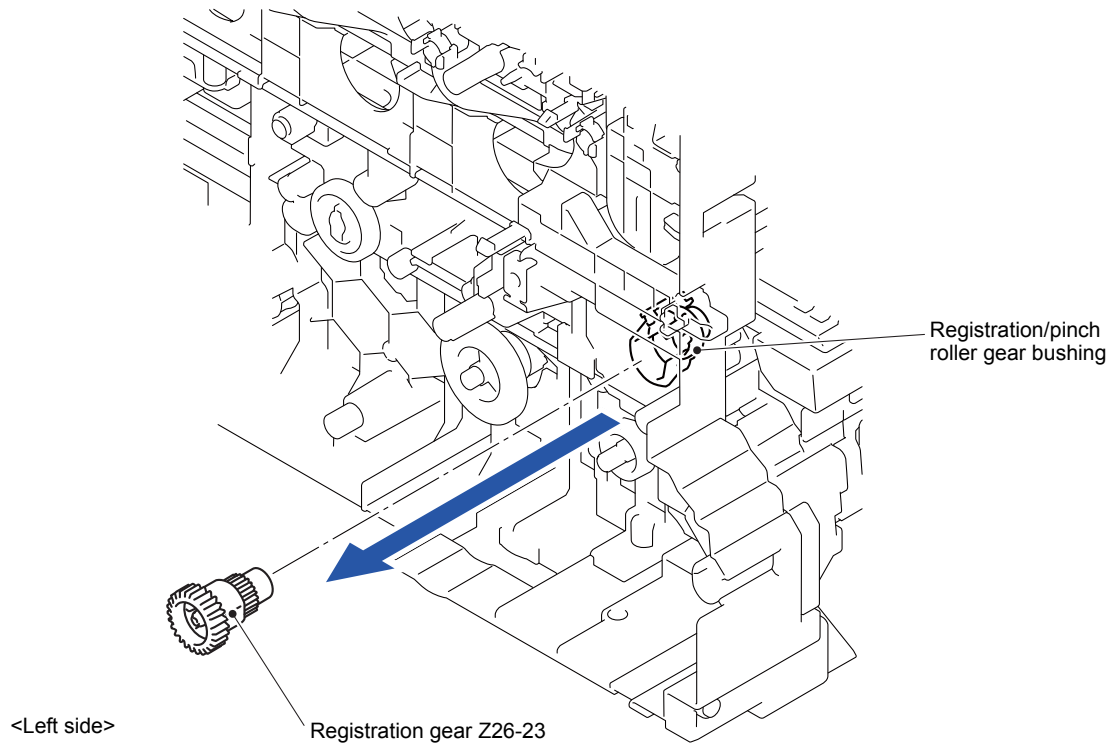

Fig. 3-238

(7) Remove the Pinch roller drive gear Z21M05 from the Registration/pinch roller gear bushing.

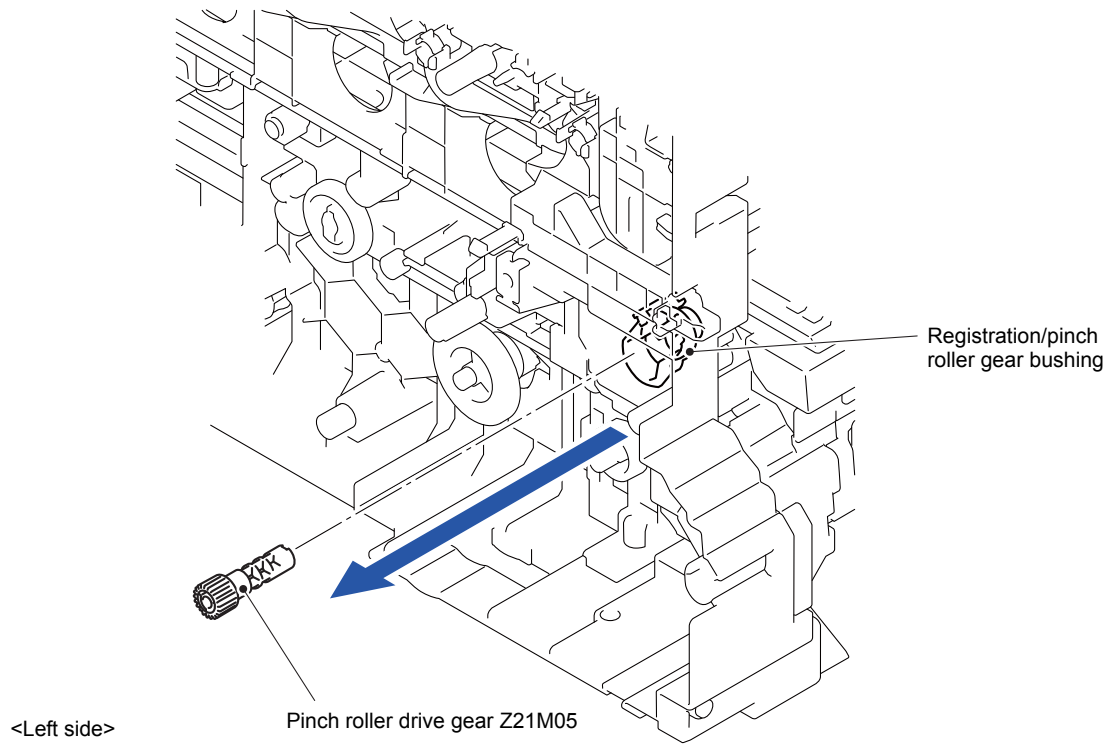

Fig. 3-239

- (8) Release the Hook and remove the Registration/pinch roller gear bushing from the Main body.
- (9) Release the wiring of the Registration/pinch roller gear bushing.

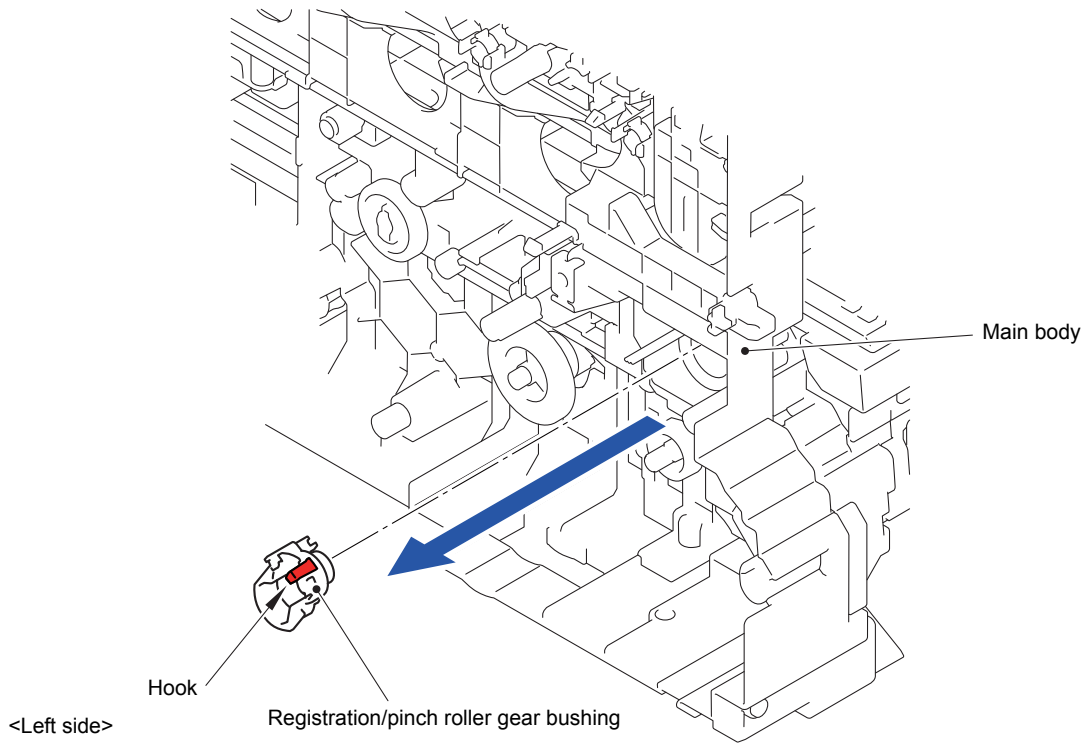

Fig. 3-240

- (10) Slide the MP drive shaft as shown in the figure.
- (11) Remove the two Taptite bind B M3x10 screws from the MP upper cover ASSY. Release the two Hooks and remove the MP upper cover ASSY from the MP lower chute ASSY.

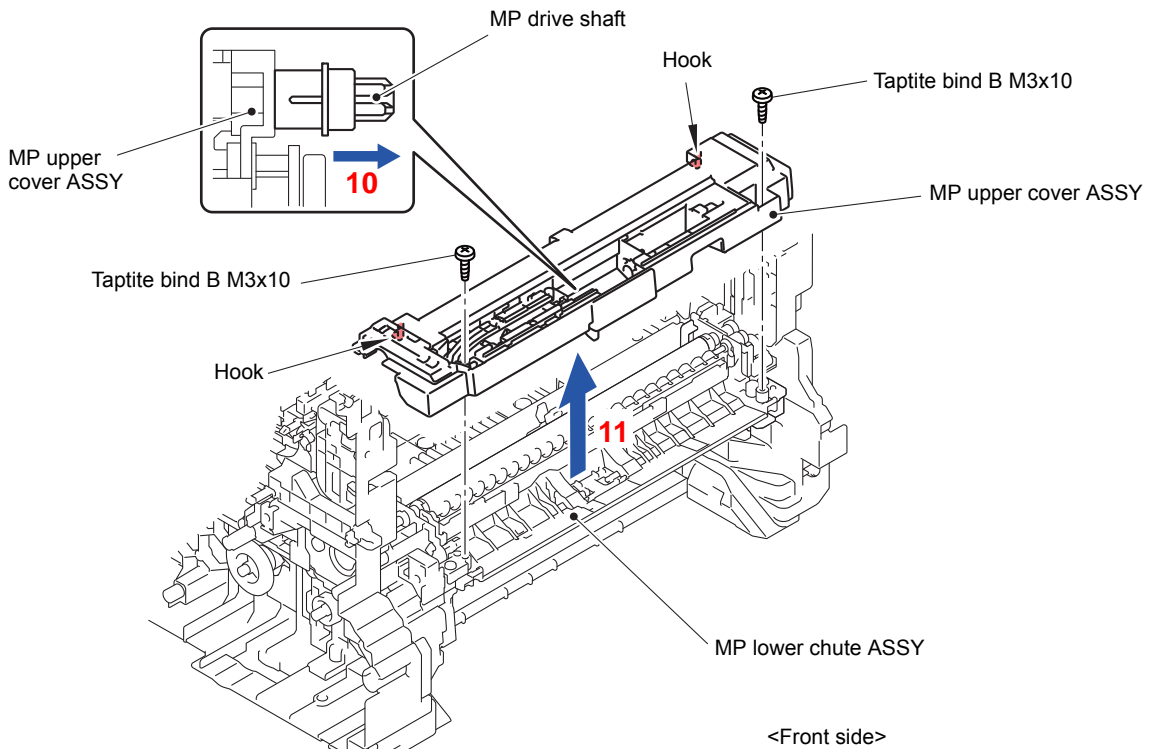

Fig. 3-241

Assembling Note:

When assembling the MP upper cover ASSY, attach "A" of the MP lift arm A to the MP lift lever.

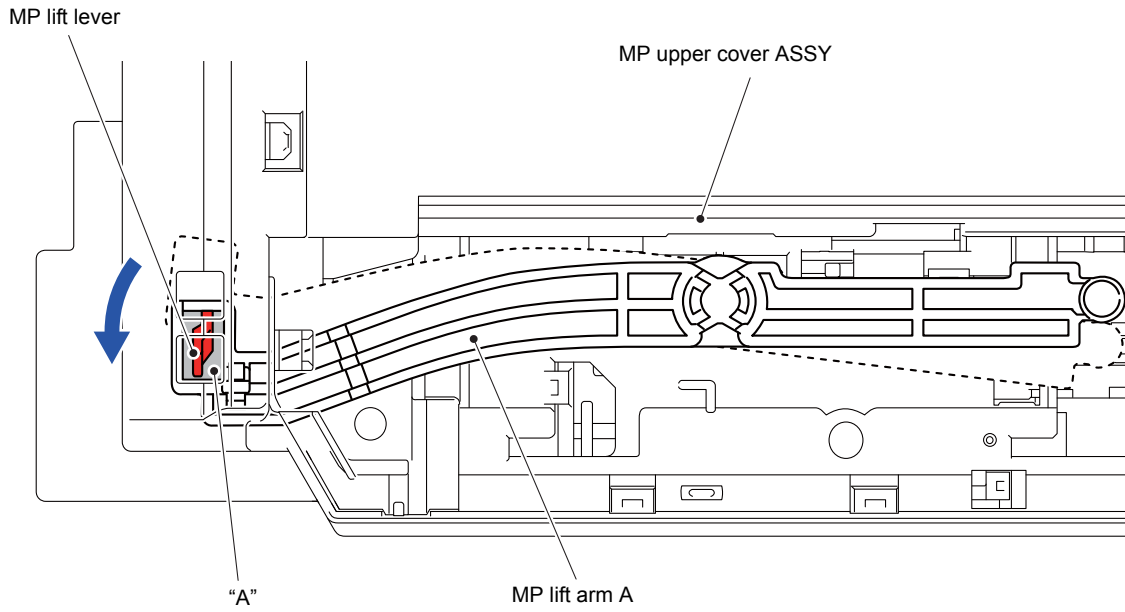

Fig. 3-242

(12) Release the five Hooks and remove the Sensor cover MP from the MP upper cover ASSY.

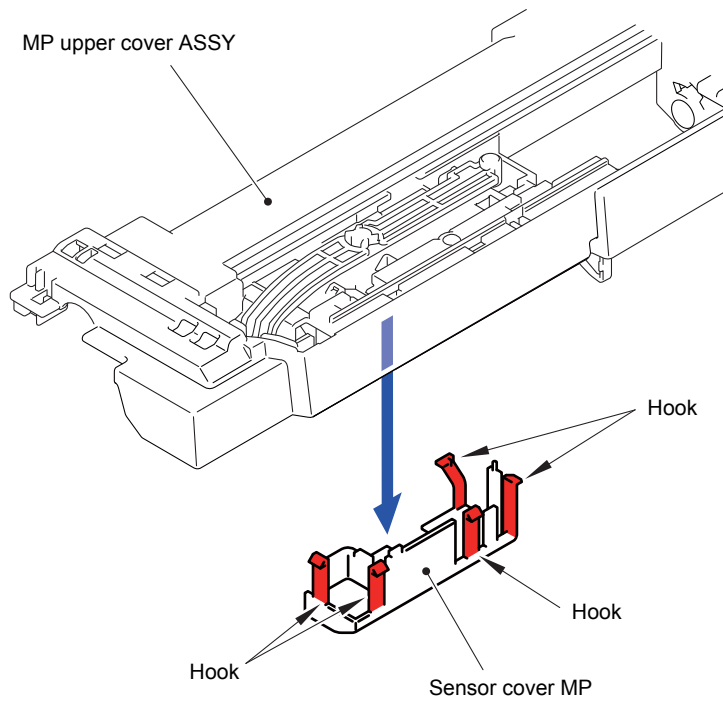

Fig. 3-243

(13) Release the two Hooks and remove the MP paper empty actuator A ASSY from the MP upper cover ASSY.

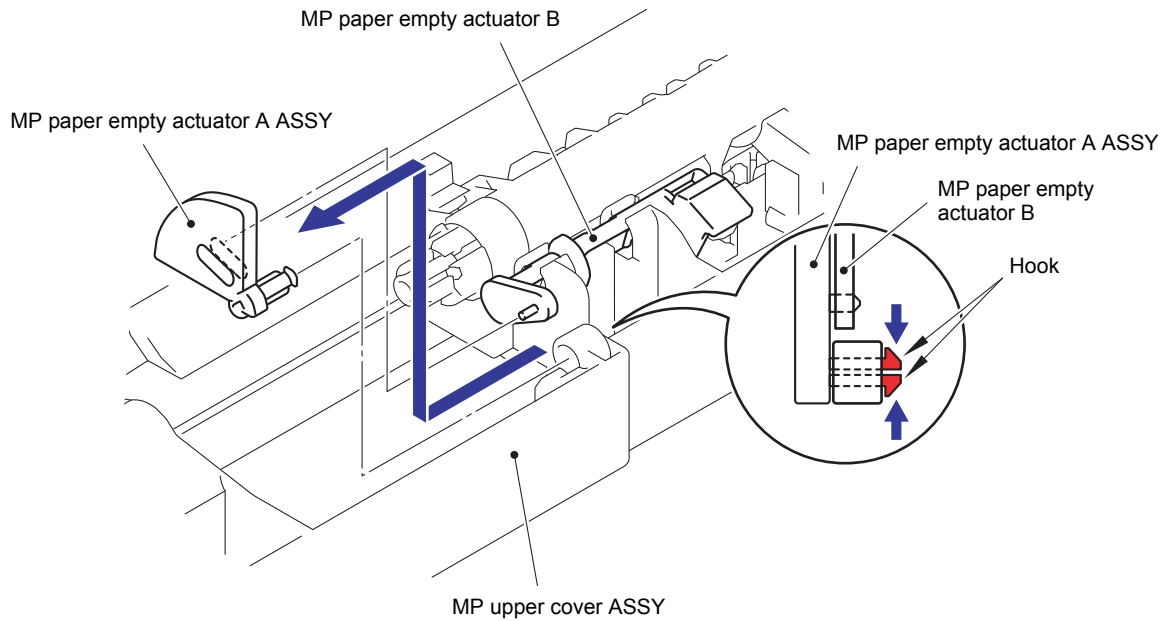

Fig. 3-244

(14) Release the Hook and remove the MP paper empty actuator B from the MP upper cover ASSY.

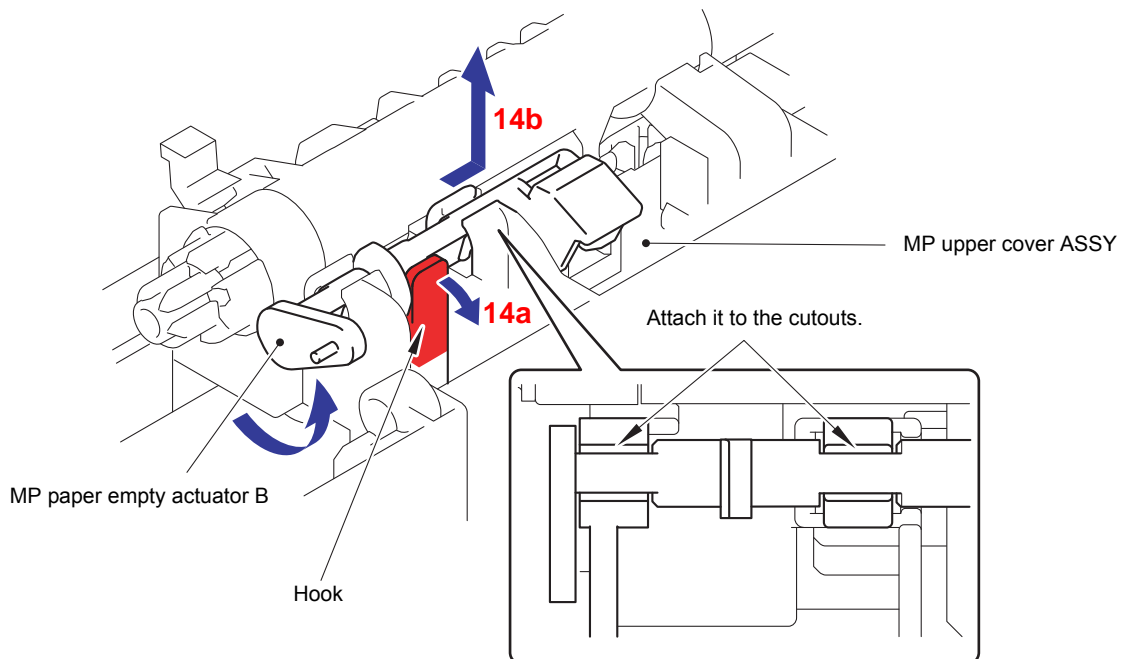

Fig. 3-245

9.64 MP Paper Empty/Registration Front Sensor PCB ASSY

(1) Release the Hook and remove the MP separation roller bushing from the MP drive shaft.

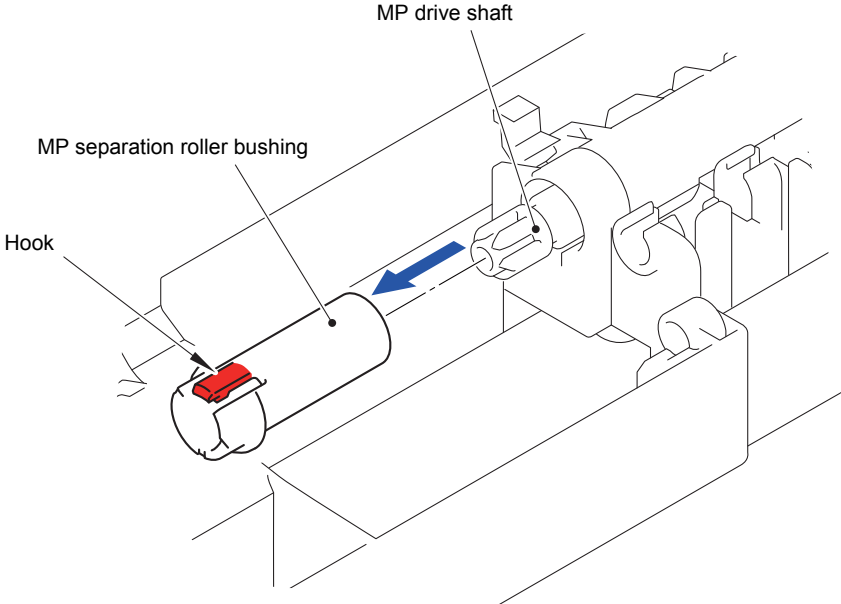

Fig. 3-246

(2) Release the two Hooks and remove the MP registration front actuator spring from the MP registration front actuator.

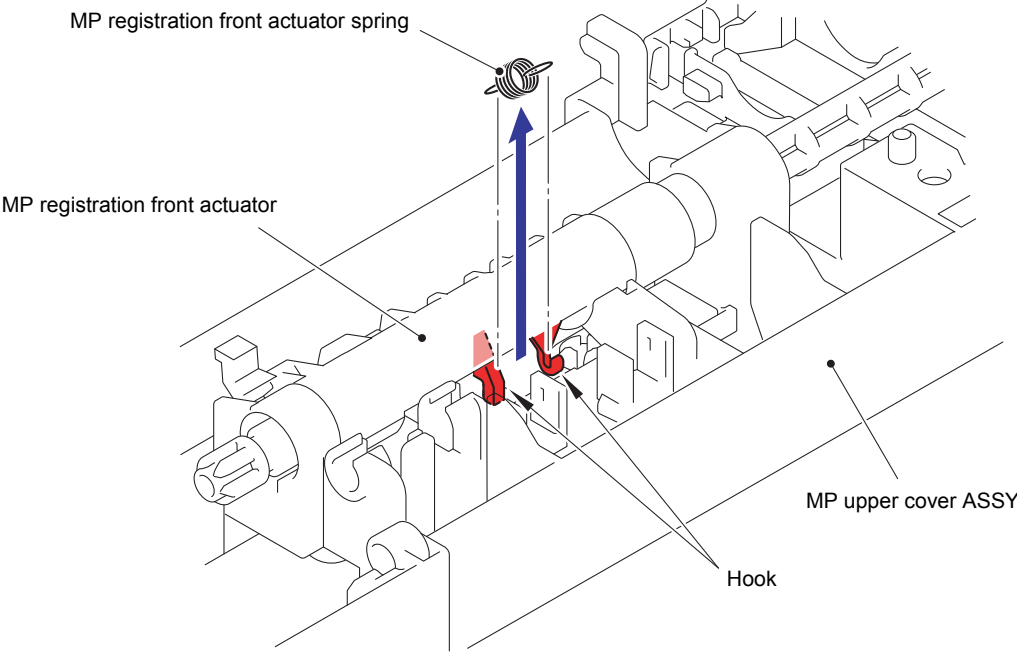

Fig. 3-247

- (3) Pull out the MP drive shaft and remove the MP registration front actuator from the MP upper cover ASSY.

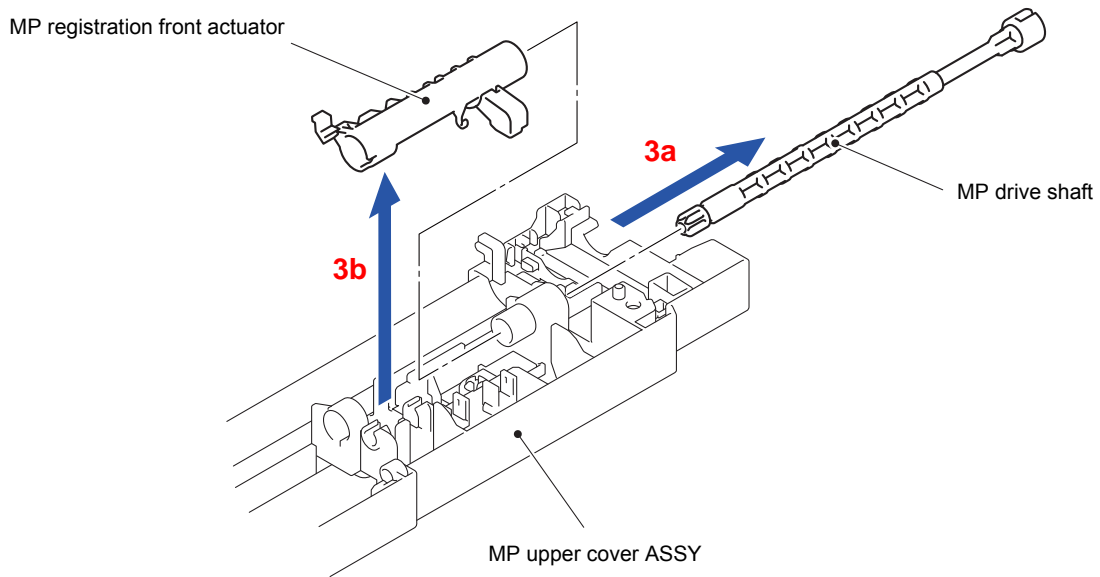

Fig. 3-248

- (4) Release the wiring of the MP paper empty/registration front sensor PCB ASSY.
- (5) Remove the Taptite bind B M3x8 screw and remove the MP paper empty/registration front sensor PCB ASSY from the MP upper cover ASSY.

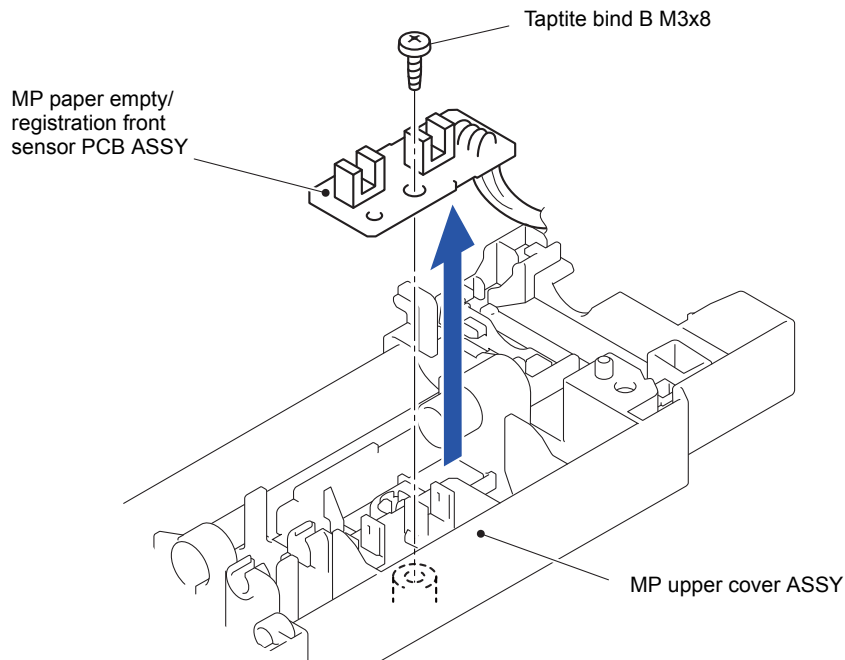

Fig. 3-249

Harness routing: Refer to “[MP Paper Empty/Registration Front Sensor PCB ASSY](#)”

9.65 Paper Feed Unit/Joint Pin

- (1) Push the T1 lift arm to the back and remove "B" of the Roller holder ASSY from "A" of the T1 lift arm.

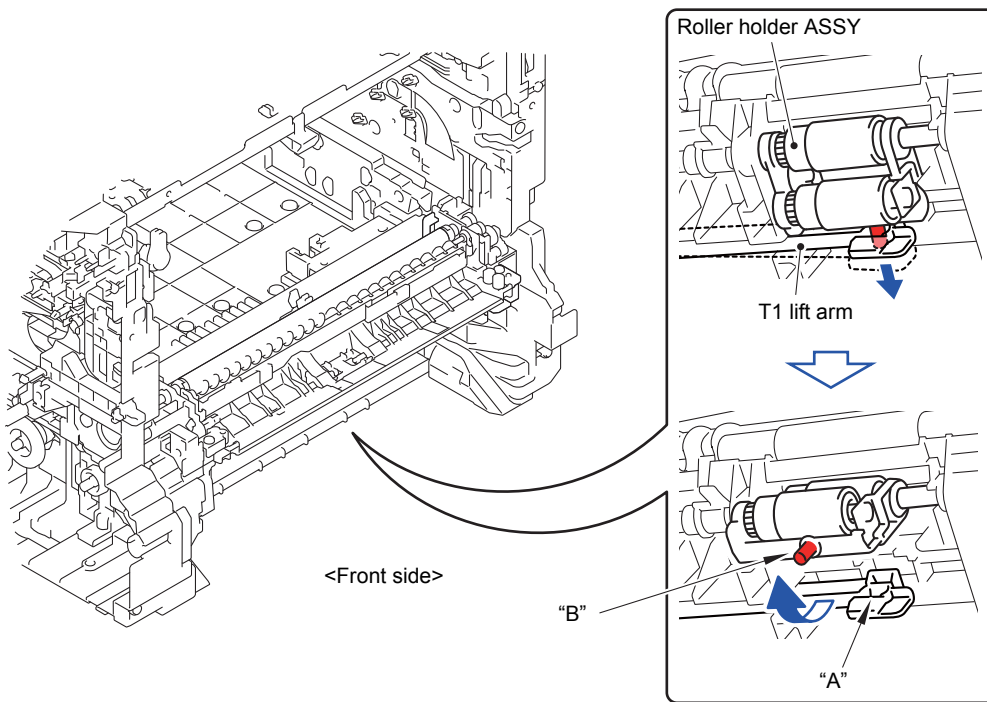

Fig. 3-250

- (2) Slide the Roller holder ASSY in the direction of the arrow and remove it from the T1 drive shaft gear Z17M07.
- (3) Slide the Roller holder ASSY in the direction of the arrow 3a and 3b in this order and remove it from the Paper feed unit.

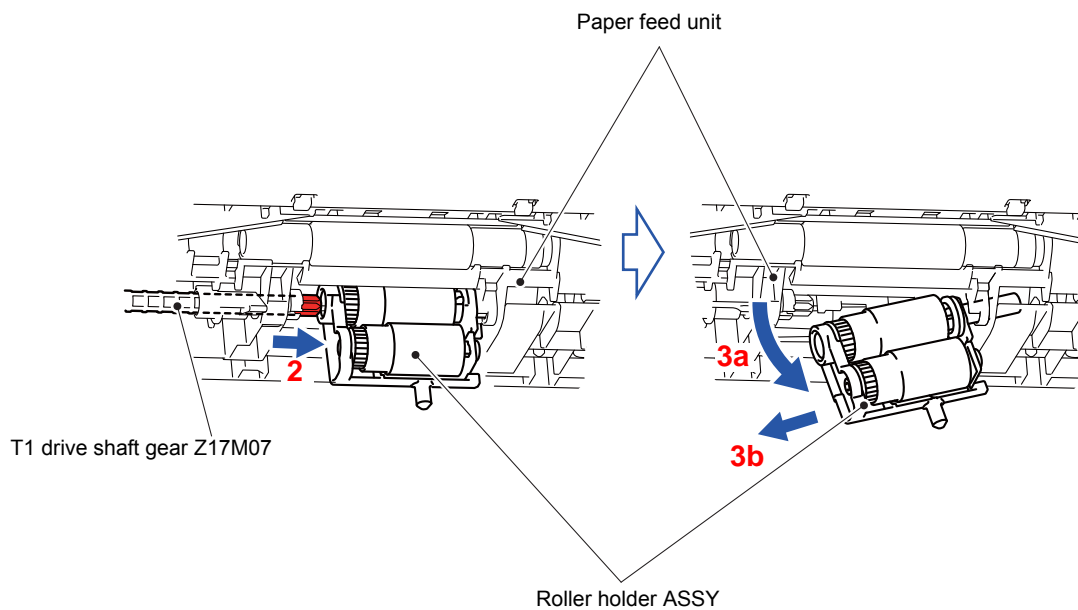

Fig. 3-251

Assembling Note:

Align the Hole of the Paper feed unit to the Shaft of the Roller holder ASSY and insert it into the Hole.

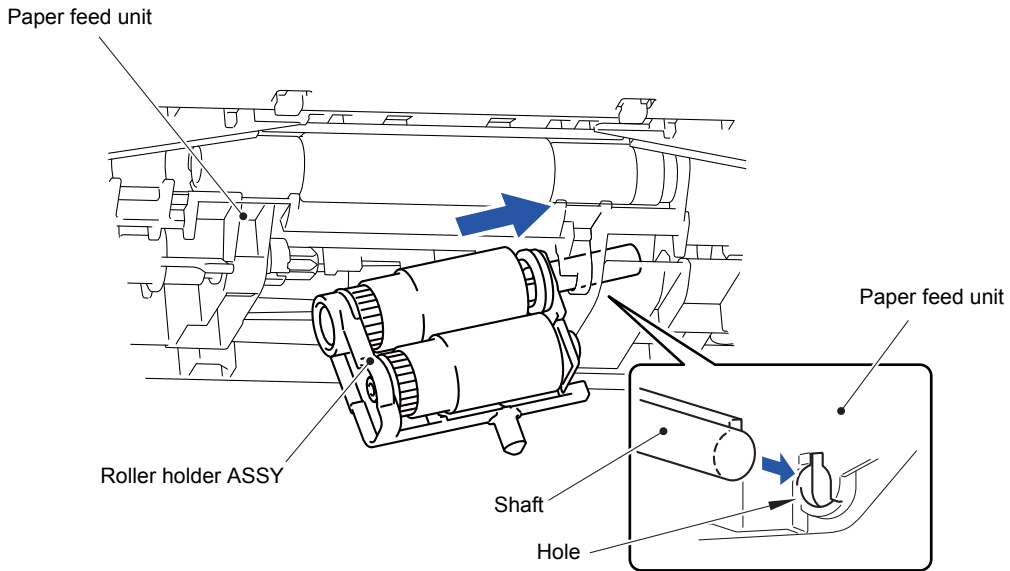

Fig. 3-252

- (4) Move the T1 lift arm in the direction of the arrow 4b as bending it in the direction of the arrow 4a and remove it from the Boss of the Paper feed unit.

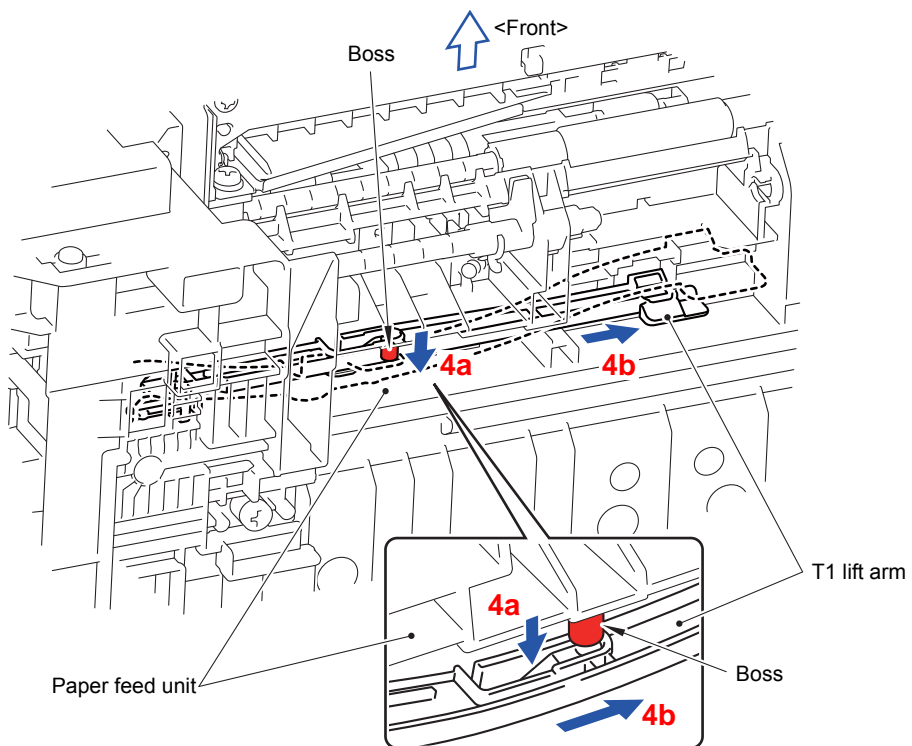

Fig. 3-253

- (5) Remove the PF drive gear 21 and PF drive joint from the Main body.

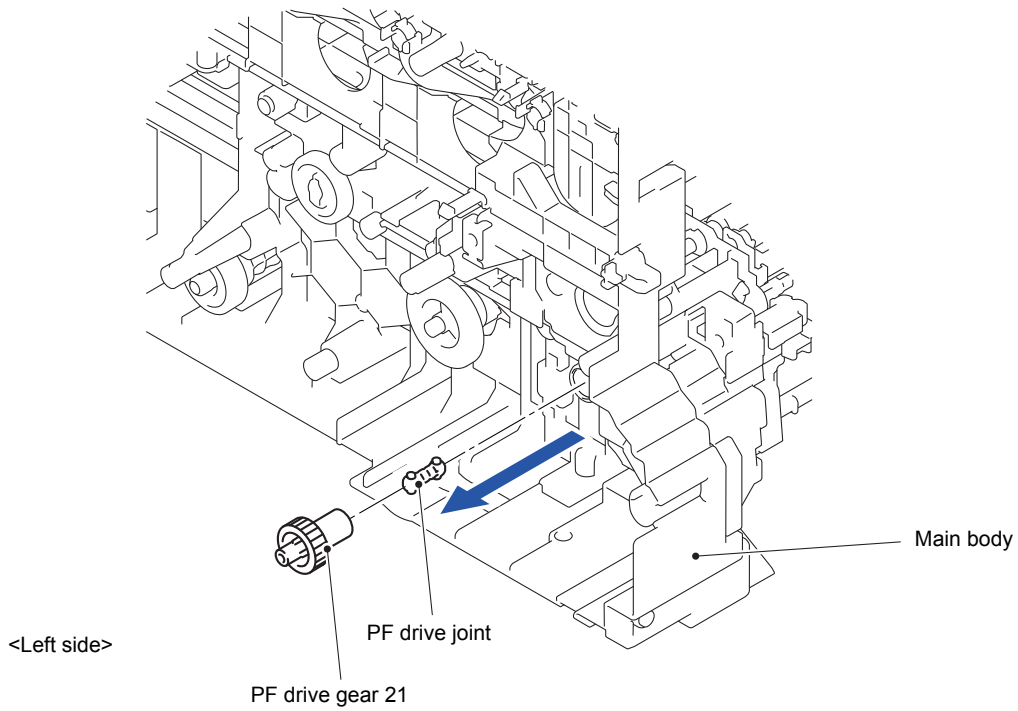

Fig. 3-254

- (6) Remove the Taptite cup B M3x12 screw from the Paper feed unit.
(7) Remove the two Taptite bind B M4x12 screws, then shift the Paper feed unit to the right, and remove it from the Main body.

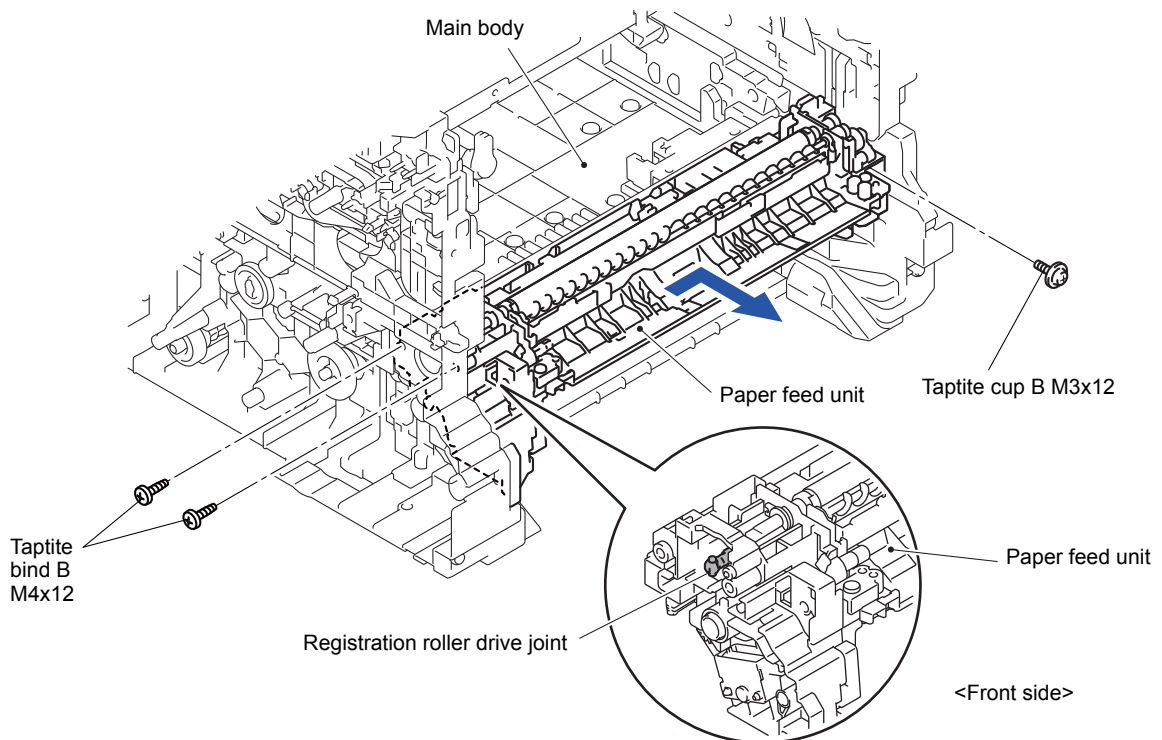

Fig. 3-255

- (8) Remove the Registration roller drive joint from the PF registration roller shaft.
- (9) Remove the Joint pin from the PF registration roller shaft.

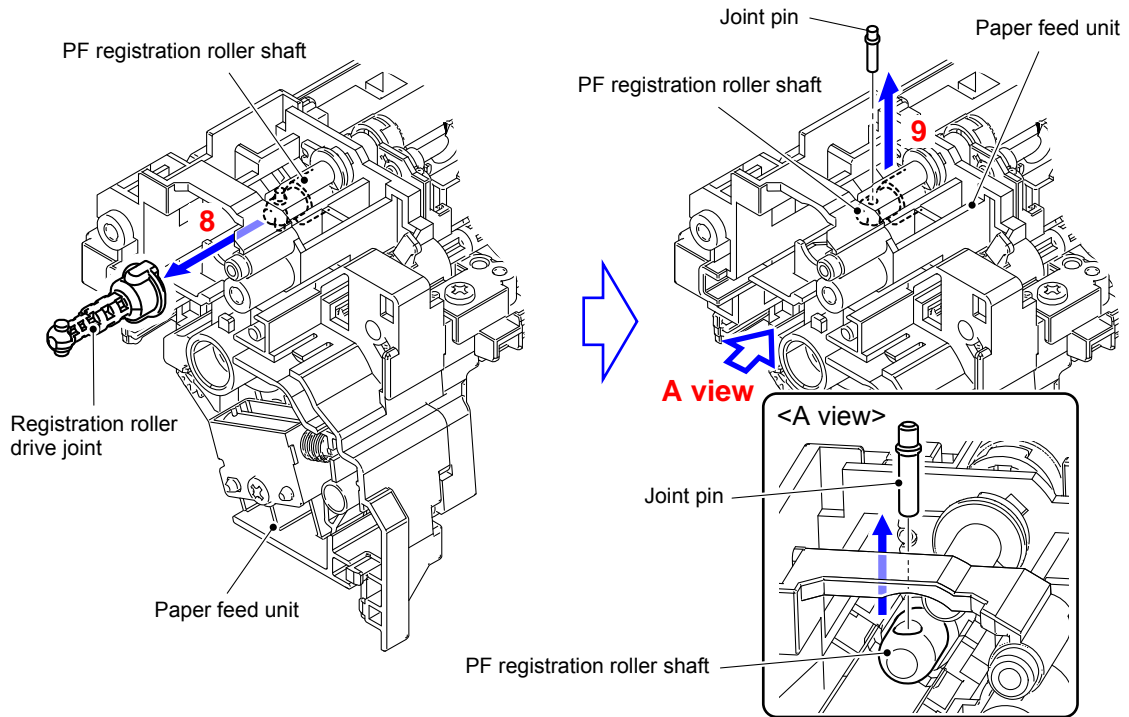

Fig. 3-256

Harness routing: Refer to “[11 Paper Feed Unit](#)”

9.66 Registration Front/Rear Sensor PCB ASSY

- (1) Release the wiring of the Registration front/rear sensor PCB ASSY.
- (2) Remove the Taptite bind B M3x10 screw and remove the Registration front/rear sensor PCB holder from the Paper feed unit.

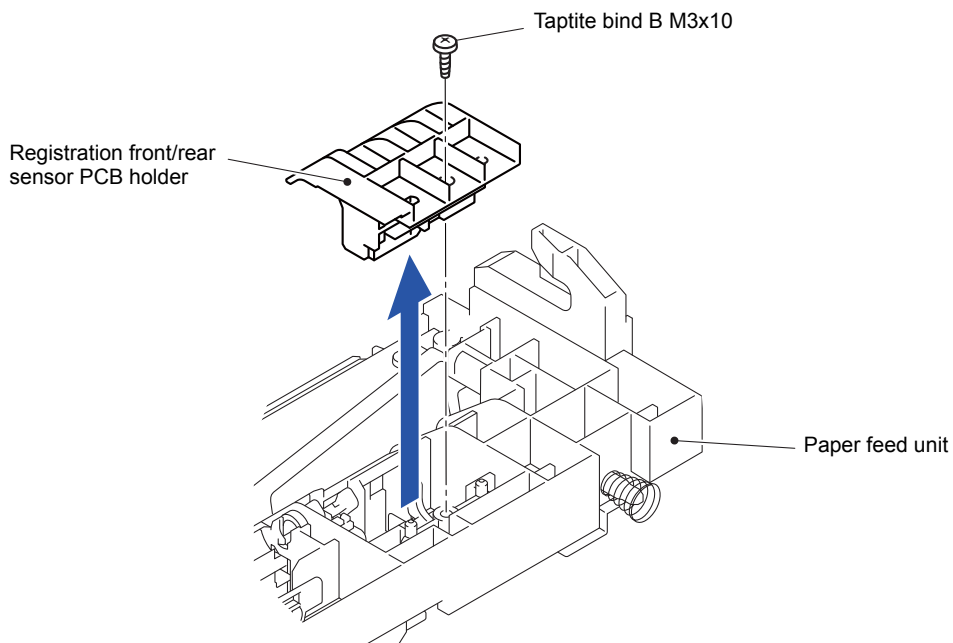

Fig. 3-257

- (3) Release the three Hooks and remove the Registration front/rear sensor PCB ASSY from the Registration front/rear sensor PCB holder.

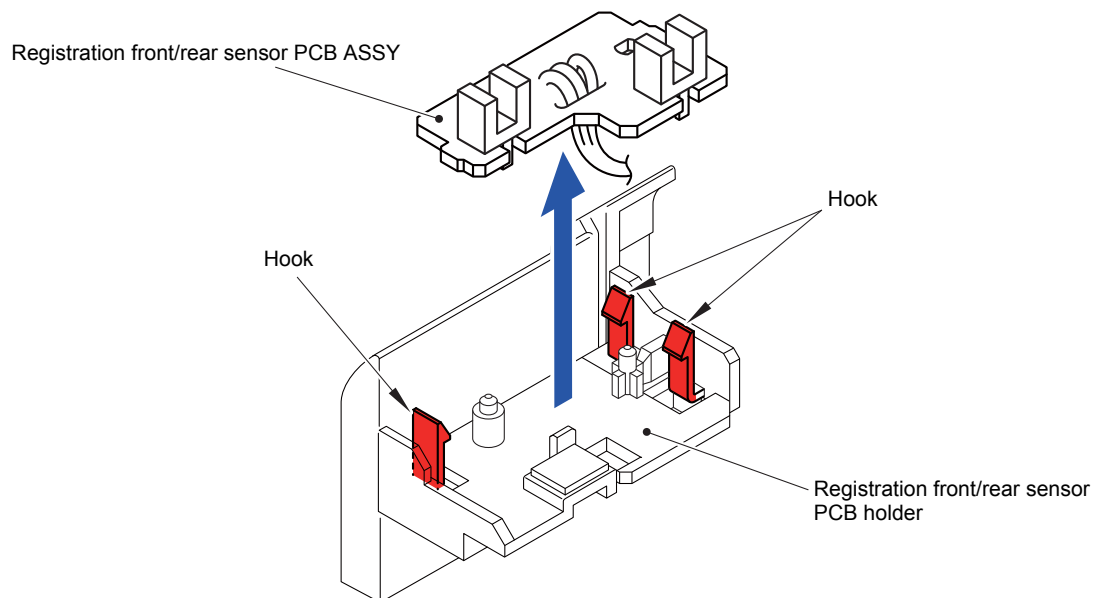

Fig. 3-258

Harness routing: Refer to “[11 Paper Feed Unit](#)”

9.67 T1 Paper Feed Sensor PCB ASSY

- (1) Release all the wiring from the MP drive frame.
- (2) Remove the three Taptite bind B M3x10 screws and remove the MP drive frame from the Paper feed unit.

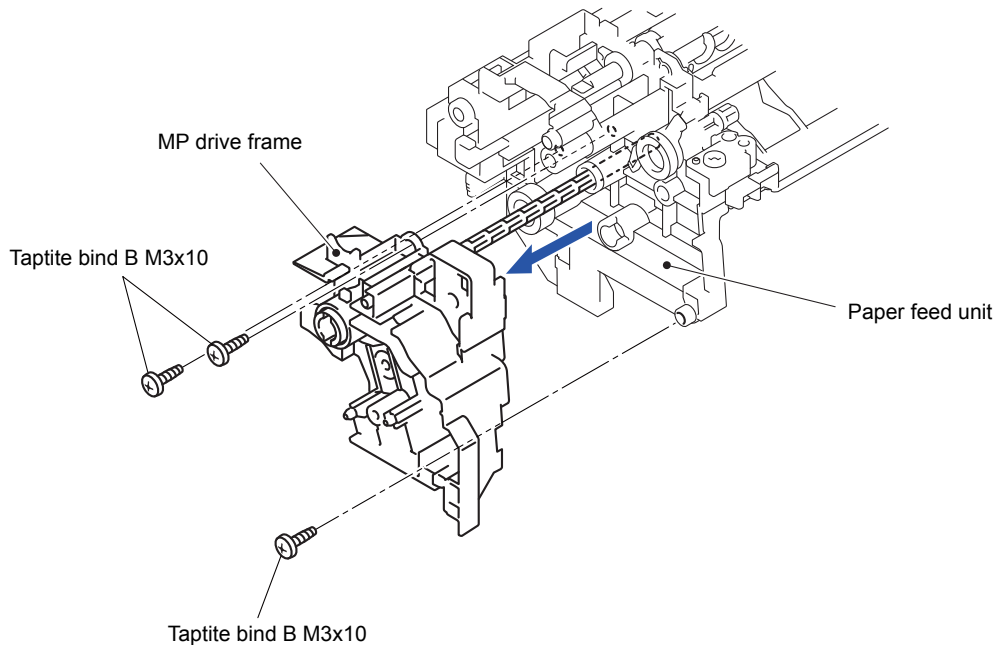

Fig. 3-259

Note:

- As the MP drive shaft gear Z17M07, MP lift lever and Registration roller drive joint tend to come off, be careful not to lose them.
- When the MP drive shaft gear Z17M07 and MP lift lever come off, assemble them as shown in the figure.

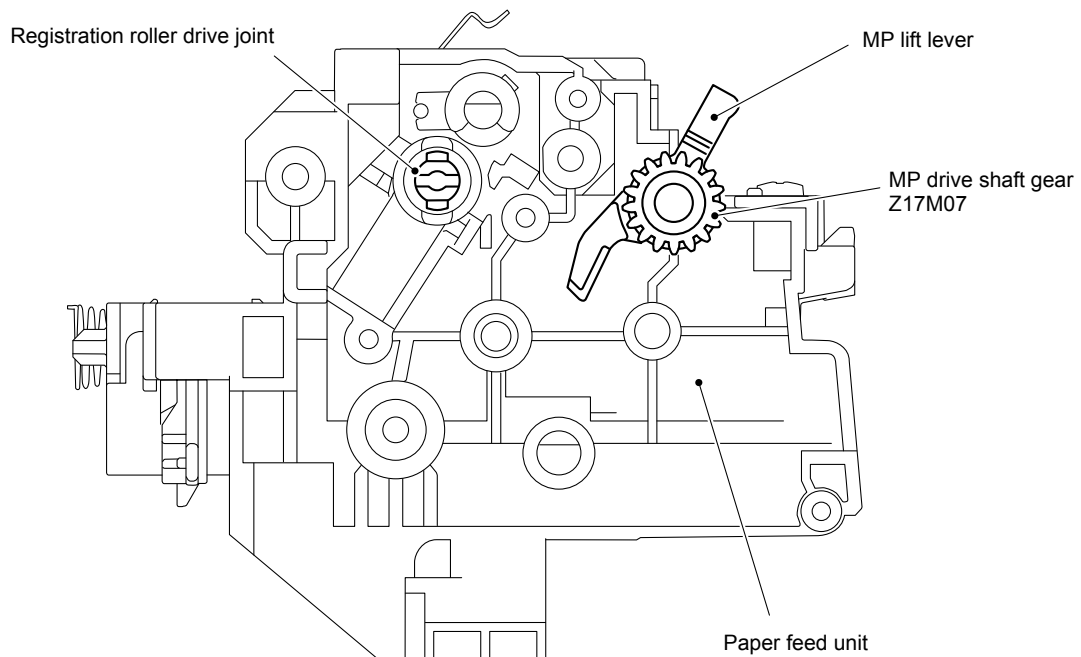

Fig. 3-260

- (3) Release the Hook and remove the Separation roller bushing from the T1 drive shaft gear Z17M07.

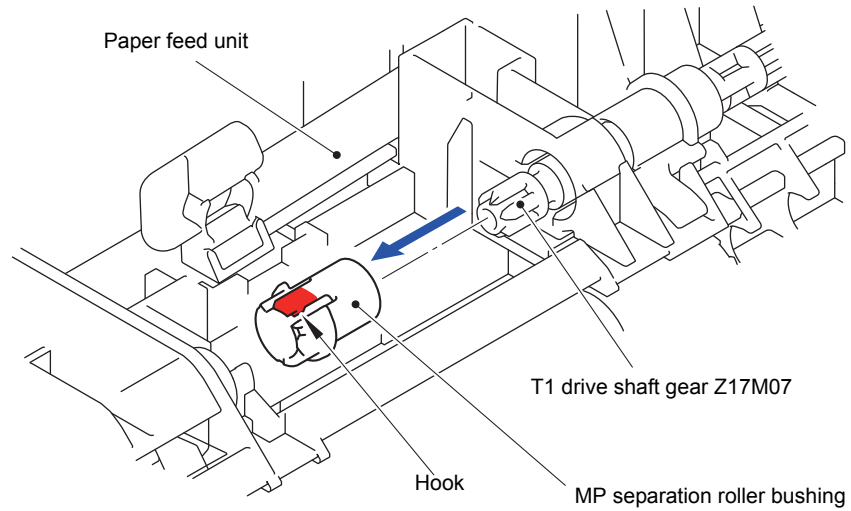

Fig. 3-261

- (4) Remove the Edge actuator spring from the Hook of the Paper feed unit and the Hook of the Edge actuator.

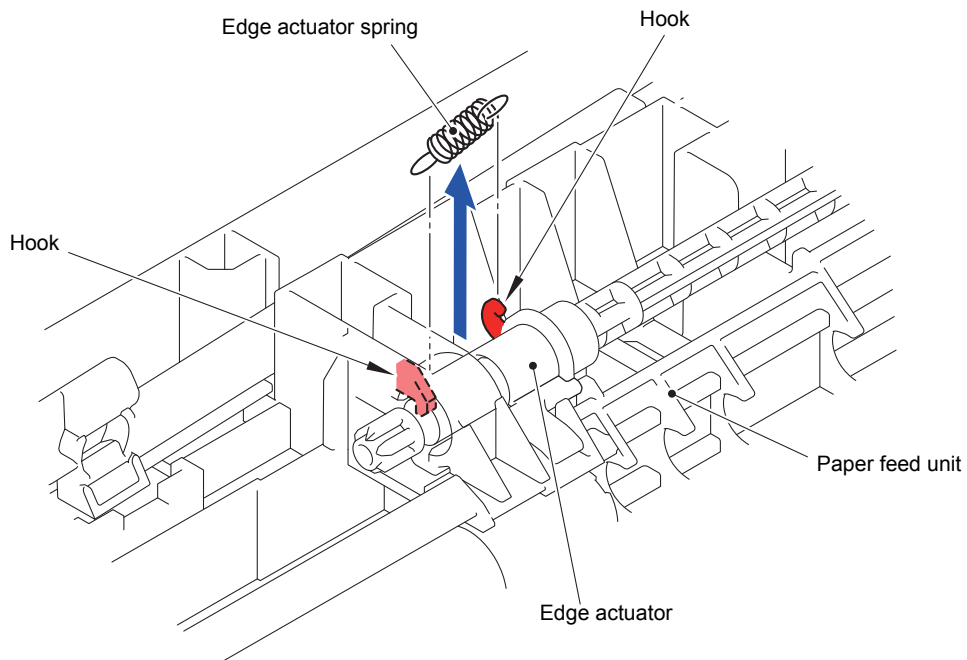

Fig. 3-262

- (5) Pull out the T1 drive shaft gear Z17M07 from the Paper feed unit and remove the Edge actuator.

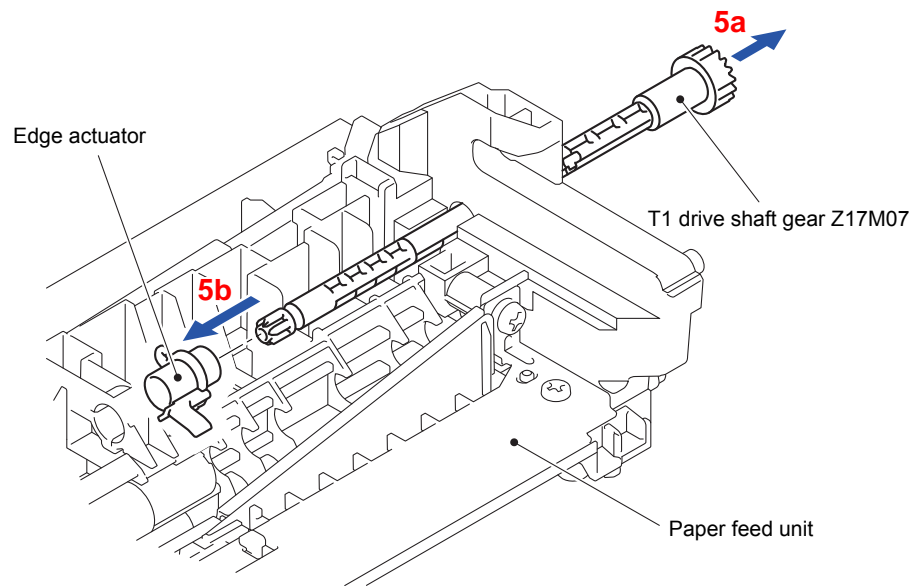

Fig. 3-263

- (6) Release the wiring of the T1 paper feed sensor PCB ASSY.
- (7) Release the three Hooks and remove the T1 paper feed sensor PCB ASSY from the Paper feed unit.

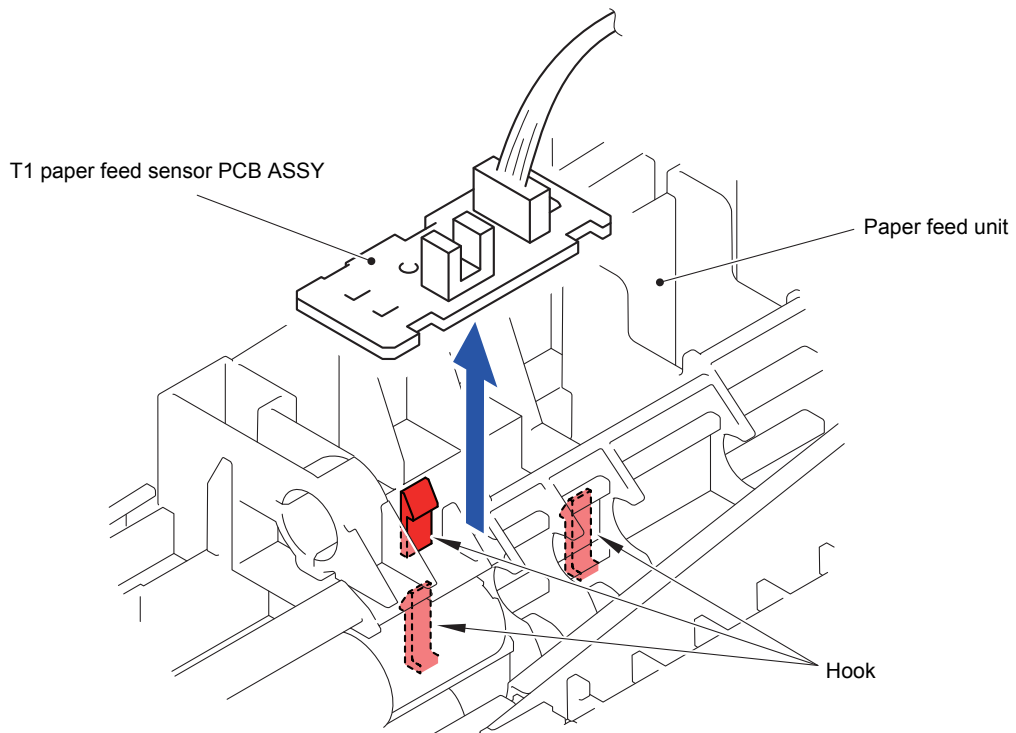

Fig. 3-264

Harness routing: Refer to "[T1 Paper Feed Unit](#)"

9.68 High-voltage Power Supply PCB ASSY

(1) Remove the four Spacers from the Main frame R ASSY.

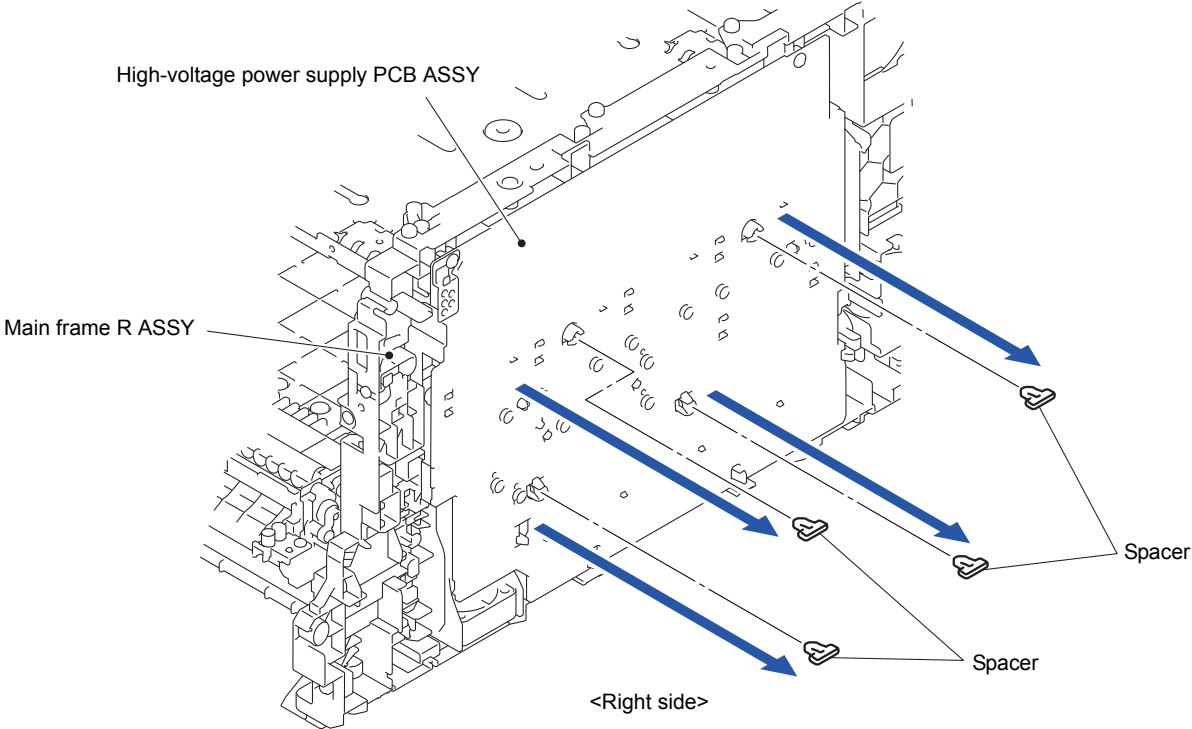

Fig. 3-265

(2) Disconnect the two Connectors (CN6 and CN7) from the High-voltage power supply PCB ASSY.

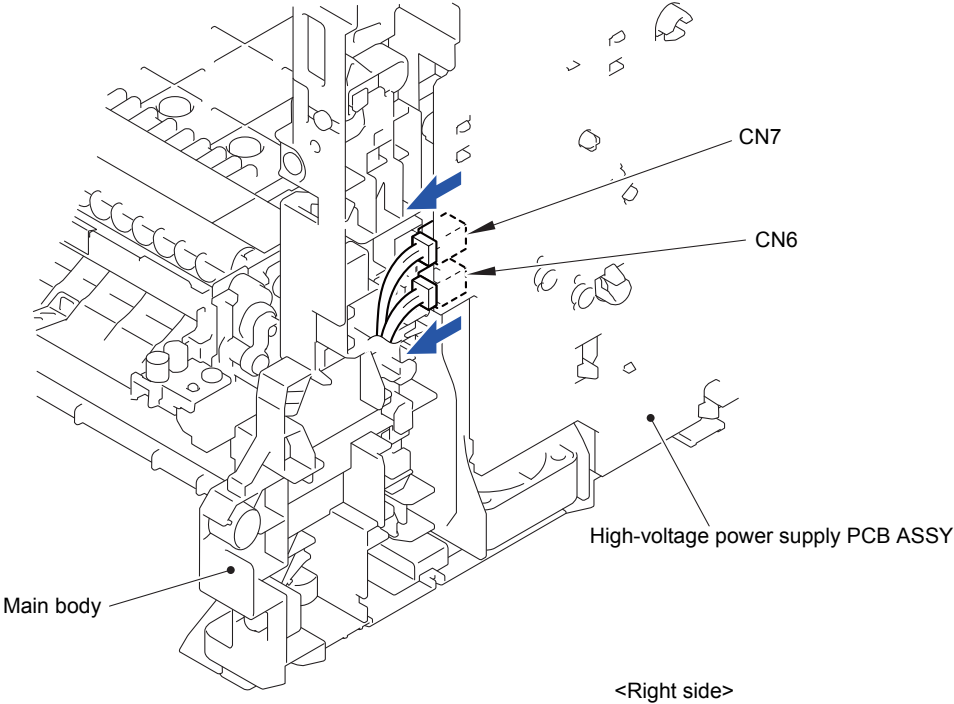

Fig. 3-266

- (3) Remove the Taptite pan B M3x10 screw from the High-voltage power supply PCB ASSY. Release the eight Hooks and remove the High-voltage power supply PCB ASSY from the Main body.

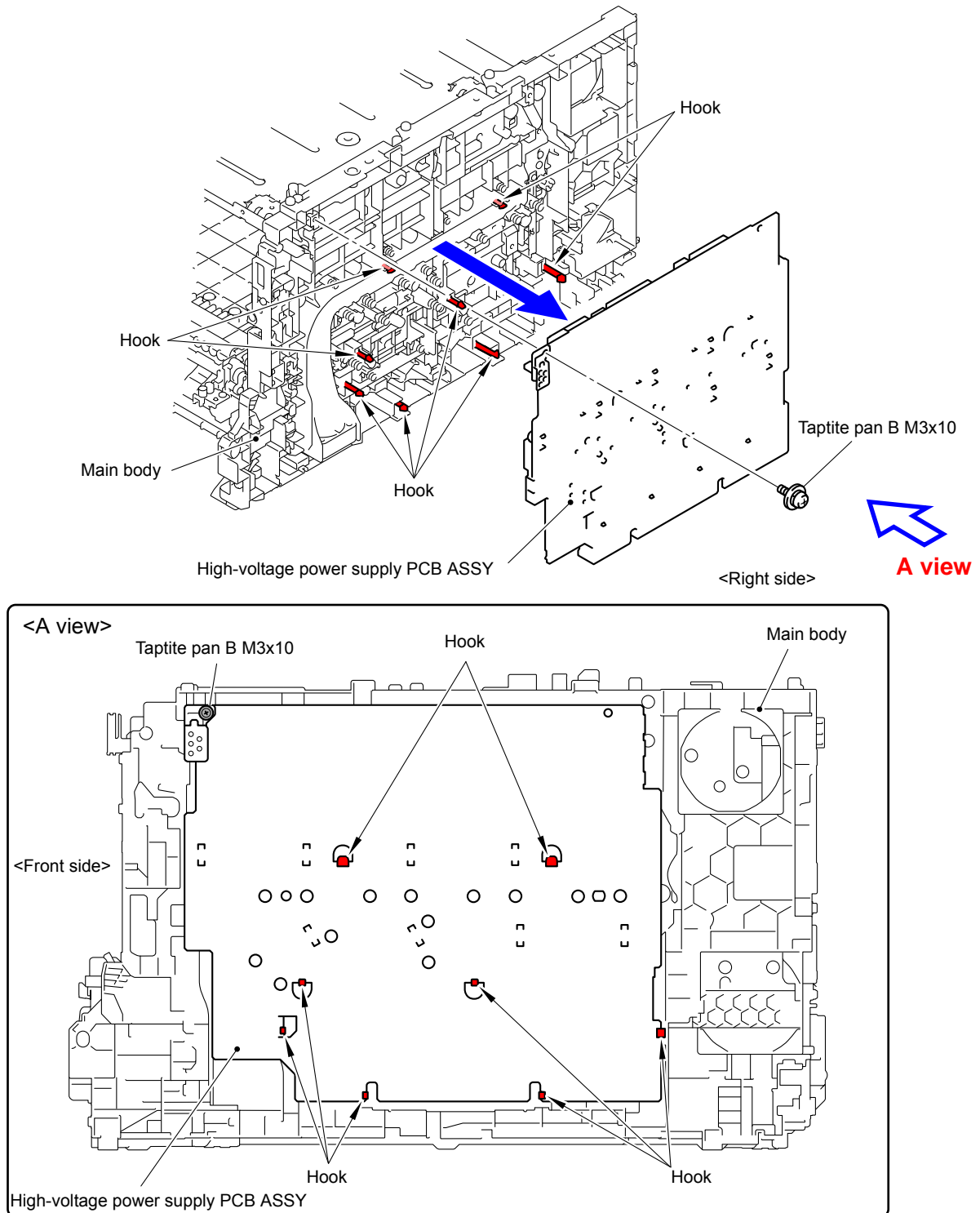

Fig. 3-267

- (4) Release the Hook and remove the HVPS shield ASSY from the High-voltage power supply PCB ASSY.

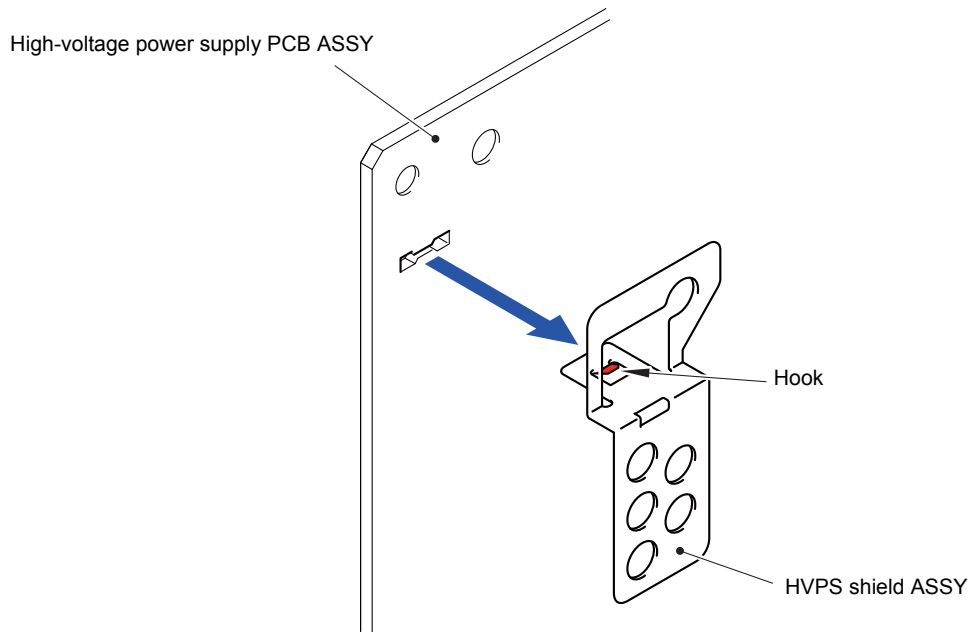

Fig. 3-268

Assembling Note:

After assembling the High-voltage power supply PCB ASSY, check that the Electrode inside the machine does not fall and that you do not feel that the Electrode gets caught when you press it.

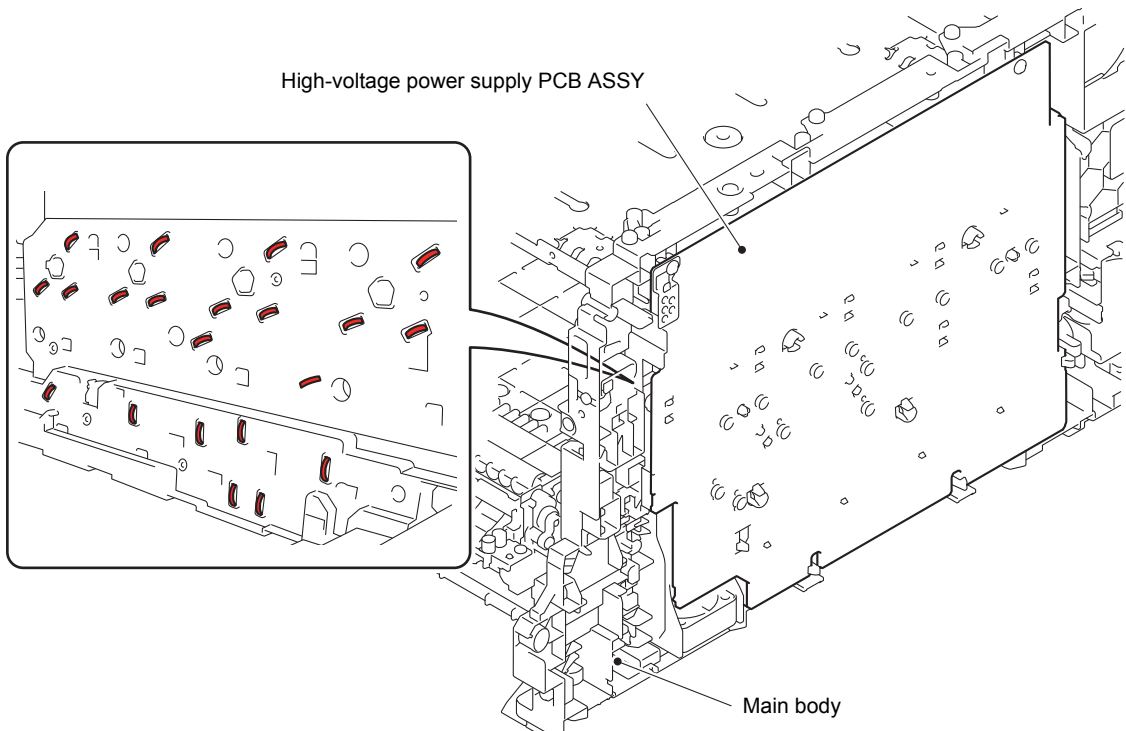

Fig. 3-269

9.69 Air Duct Film

- (1) Remove the Air duct film from the Main frame R ASSY by peeling off the Double-sided adhesive tape.

Note:

- As the Air duct protector tends to come off, be careful not to lose it.
- When removing the Air duct film, replace the Air duct film with a new one.

Assembling Note:

When assembling the Air duct film to the Main frame R ASSY, affix it without making clearance between the Air duct film and Main frame R ASSY.

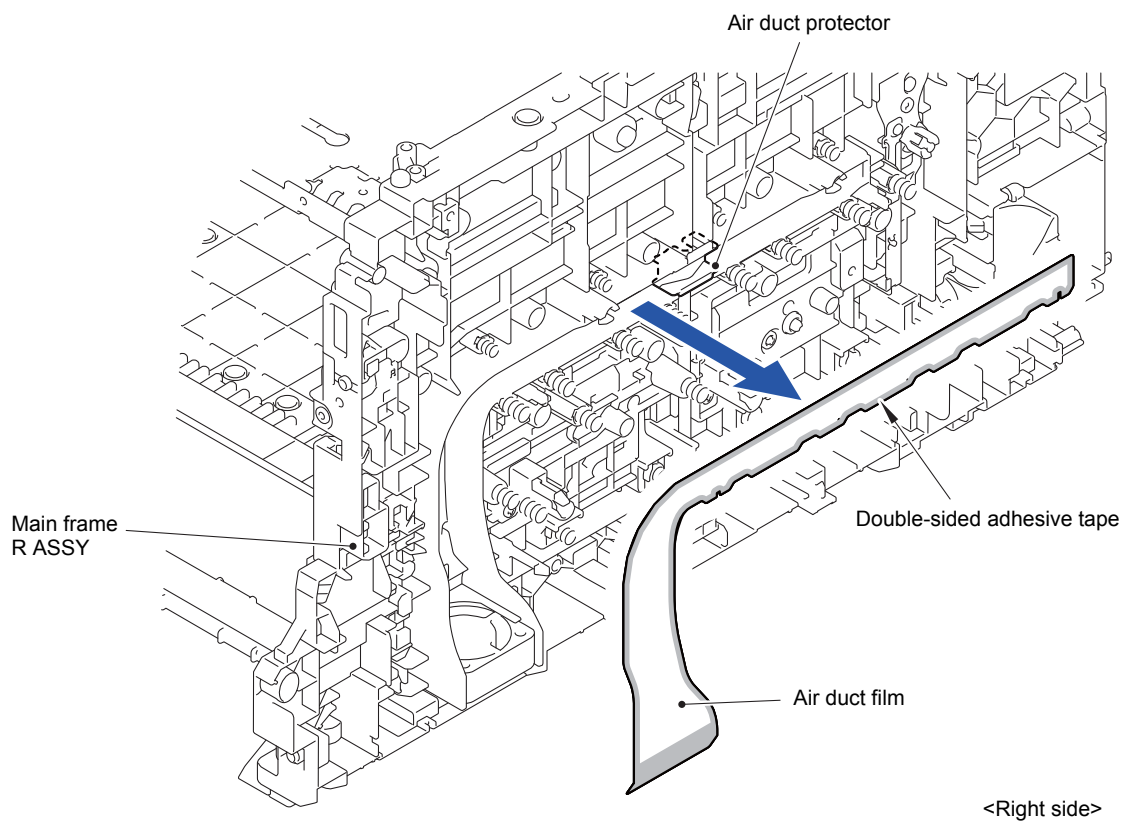

Fig. 3-270

9.70 Blower

- (1) Release the wiring of the Blower.
- (2) Remove the Blower from the Main frame R ASSY.

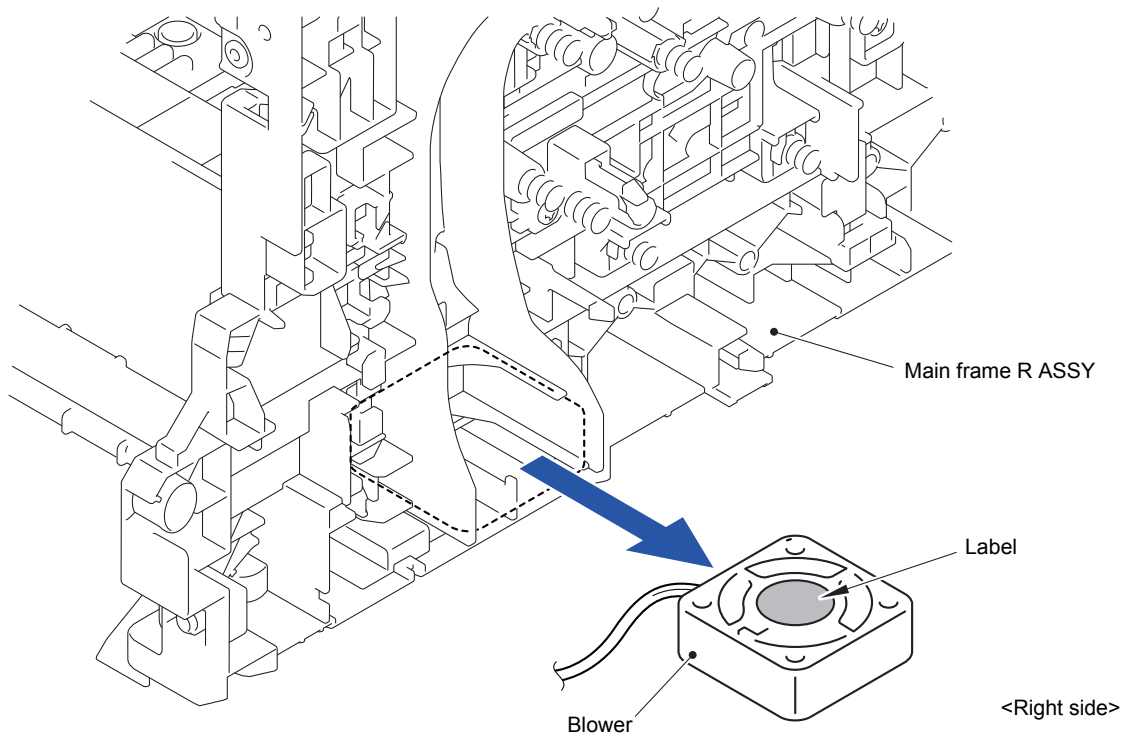

Fig. 3-271

Assembling Note:

When assembling the Blower, be sure to assemble it in a way that the label side faces out.

Harness routing: Refer to “[12 Blower, Waste Toner Sensor](#)”

10. DISASSEMBLY PROCEDURE (LT-320CL/LT-325CL)

10.1 T2 Paper Tray Unit

- (1) Take out the T2 paper tray unit from the Main body.

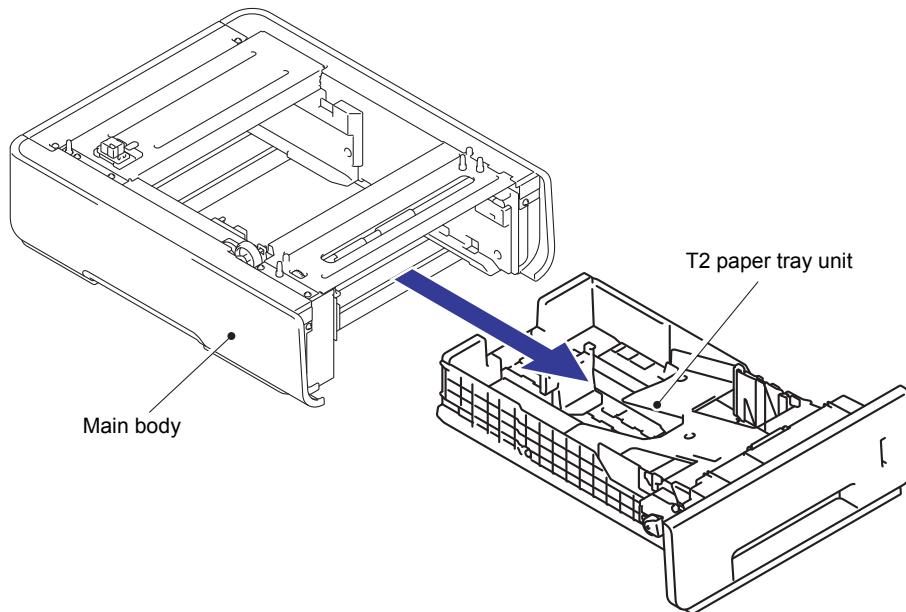

Fig. 3-272

10.2 T2 Cover Rear

- (1) Remove the two Taptite cup S M3x10 SR screws from the T2 cover rear.

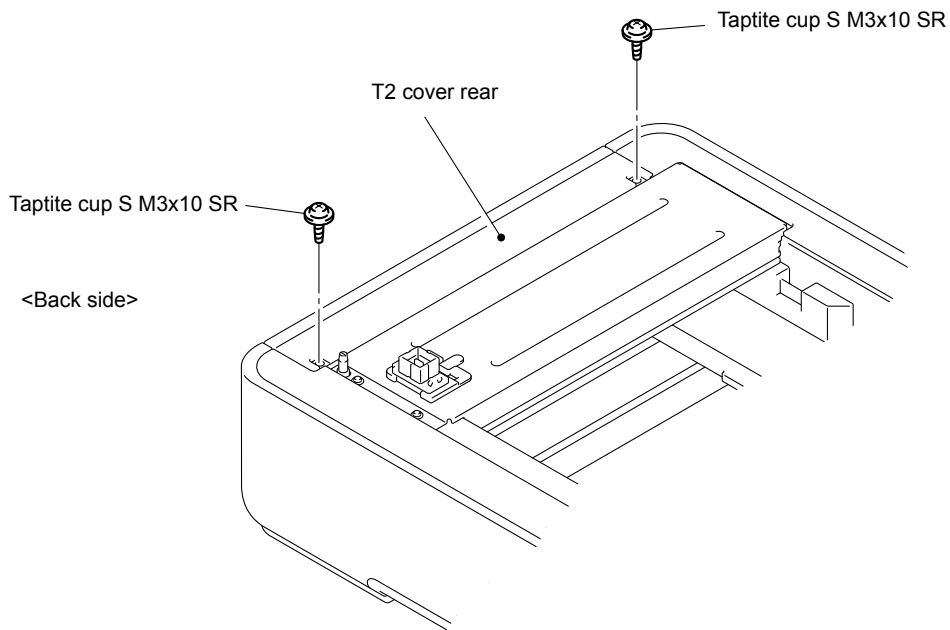

Fig. 3-273

- (2) Release the two Pins and remove the T2 cover rear from the Main body.

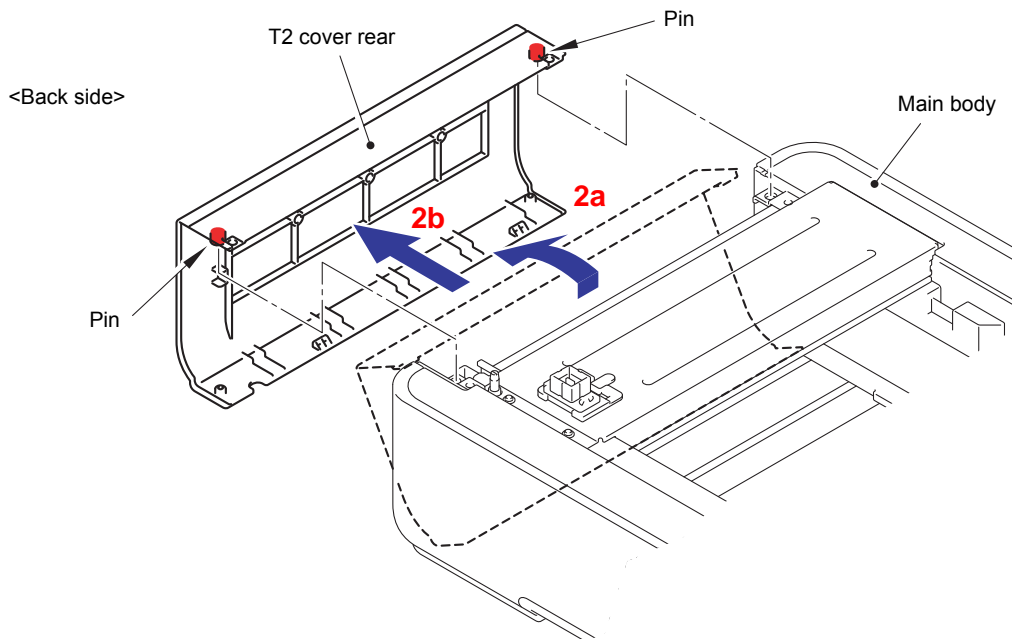

Fig. 3-274

10.3 T2 Cover Left

- (1) Remove the two Taptite cup S M3x6 SR screws from the T2 cover left.

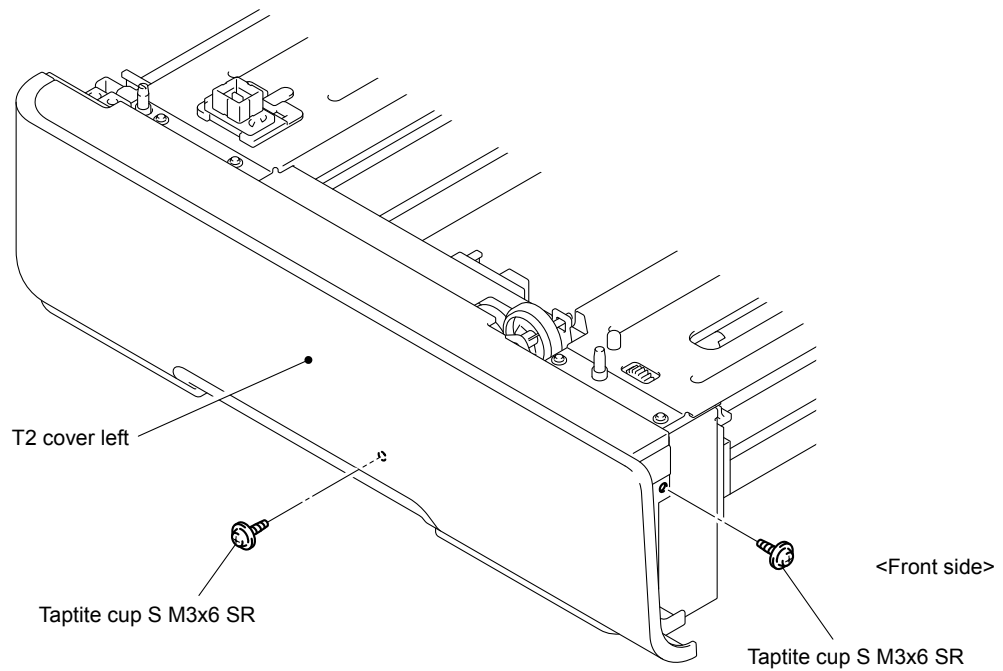

Fig. 3-275

- (2) Release the one Pin and release the two Hooks at the top.
- (3) Release the two Hooks at the bottom and remove the T2 cover left from the T2 frame L unit.

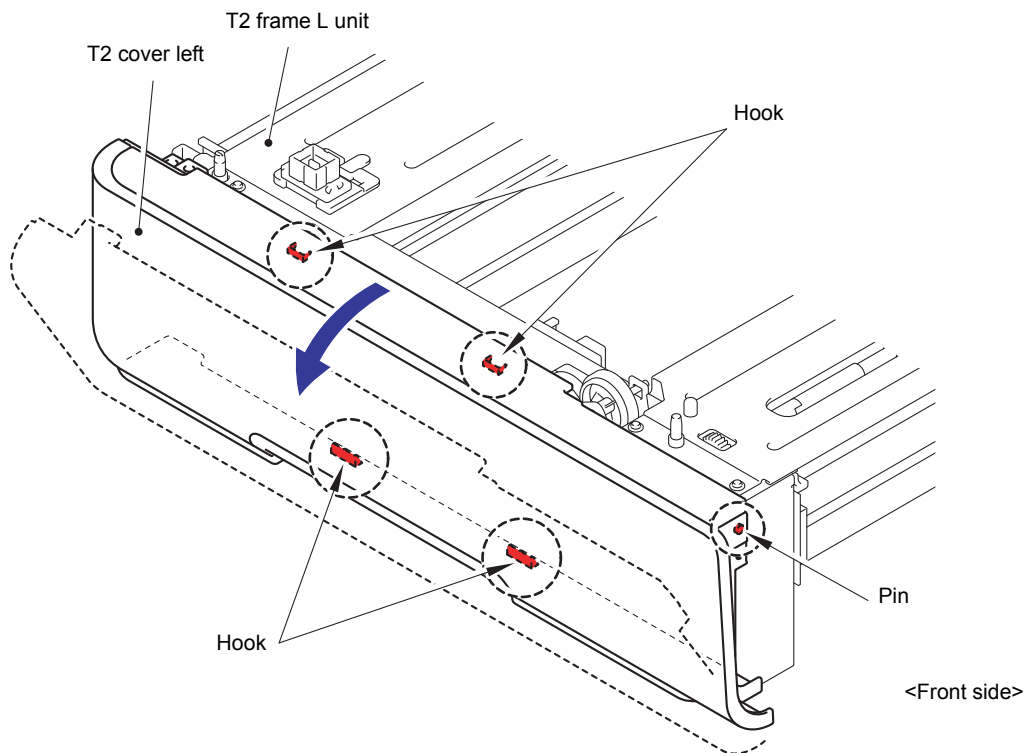

Fig. 3-276

10.4 T2 Cover Right

- (1) Remove the two Taptite cup S M3x6 SR screws from the T2 cover right.

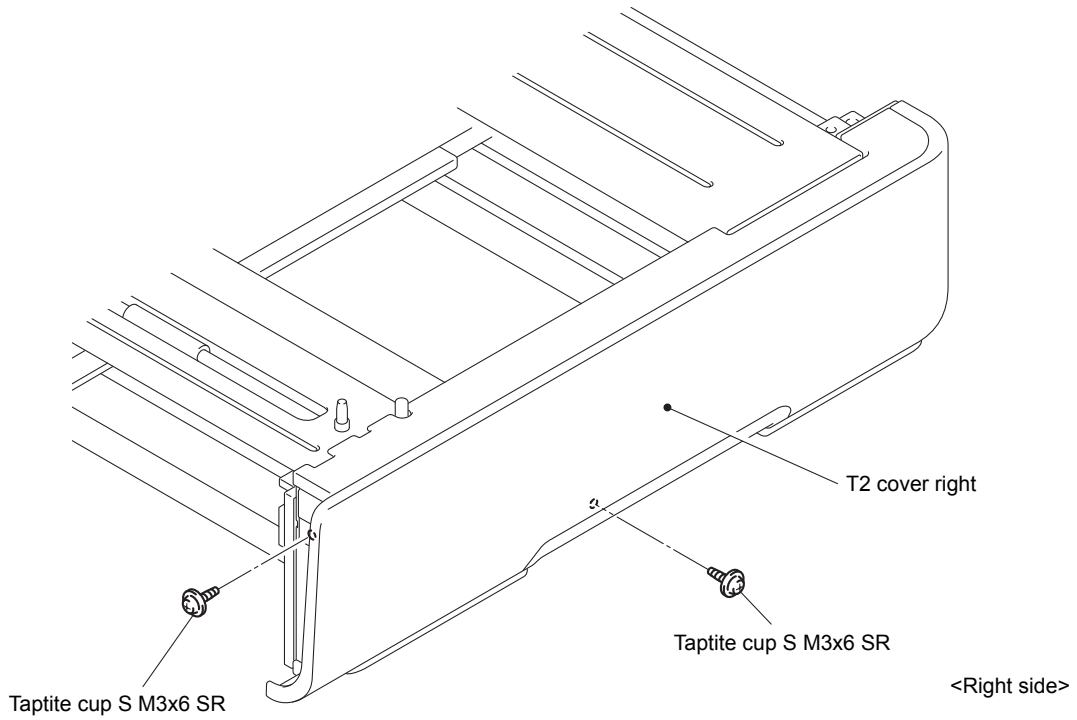

Fig. 3-277

- (2) Release the one Pin and release the two Hooks at the top.
- (3) Release the three Hooks at the bottom and remove the T2 cover right from the Main body.

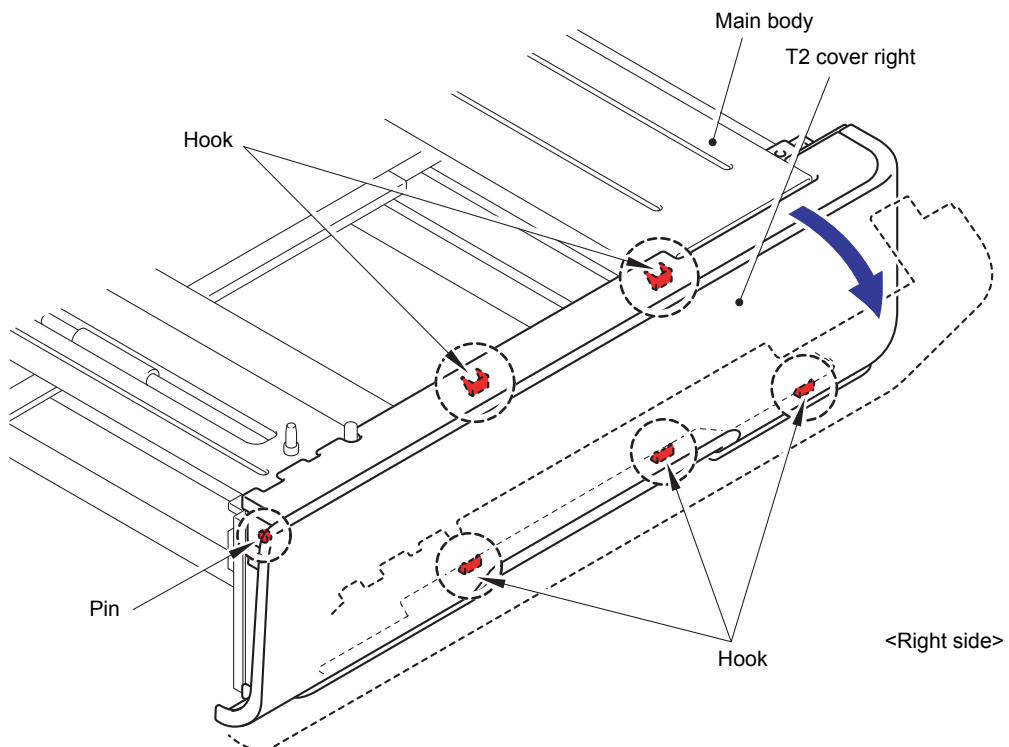

Fig. 3-278

10.5 T2 Relay PCB ASSY

- (1) Disconnect all the Connectors from the T2 relay PCB ASSY.

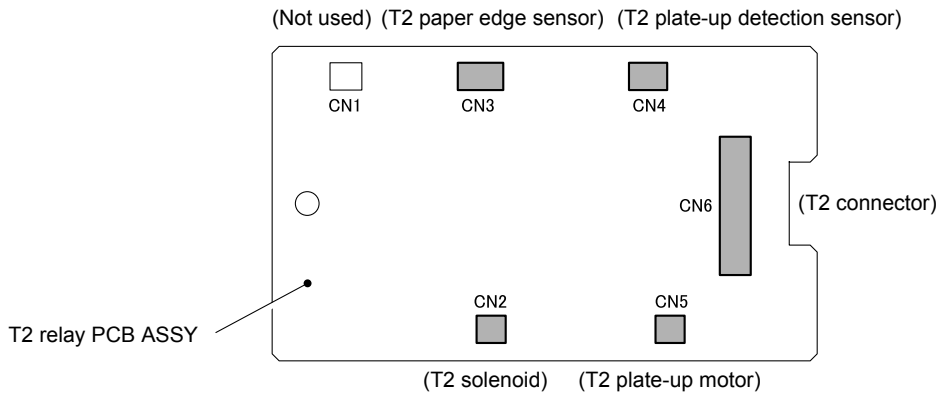

Fig. 3-279

- (2) Remove the Taptite cup S M3x6 SR screw and remove the T2 relay PCB ASSY from the T2 frame L unit.

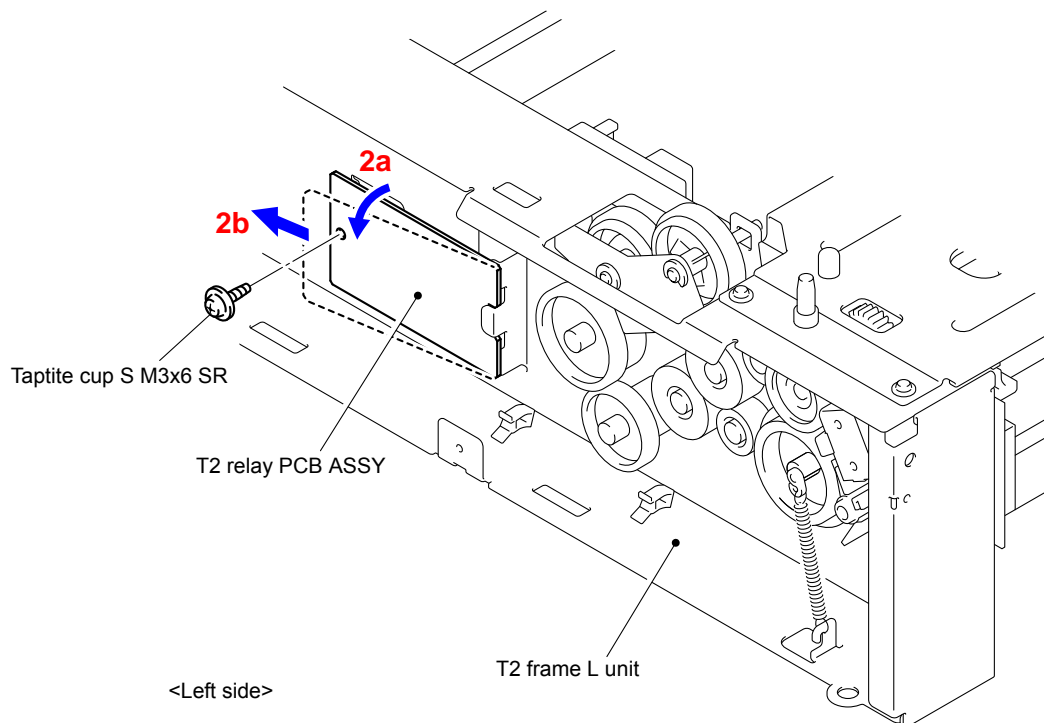

Fig. 3-280

10.6 T2 Paper Feed Frame Unit/T2 Edge Actuator

- (1) Remove the Clutch spring from the Clutch arm ASSY.

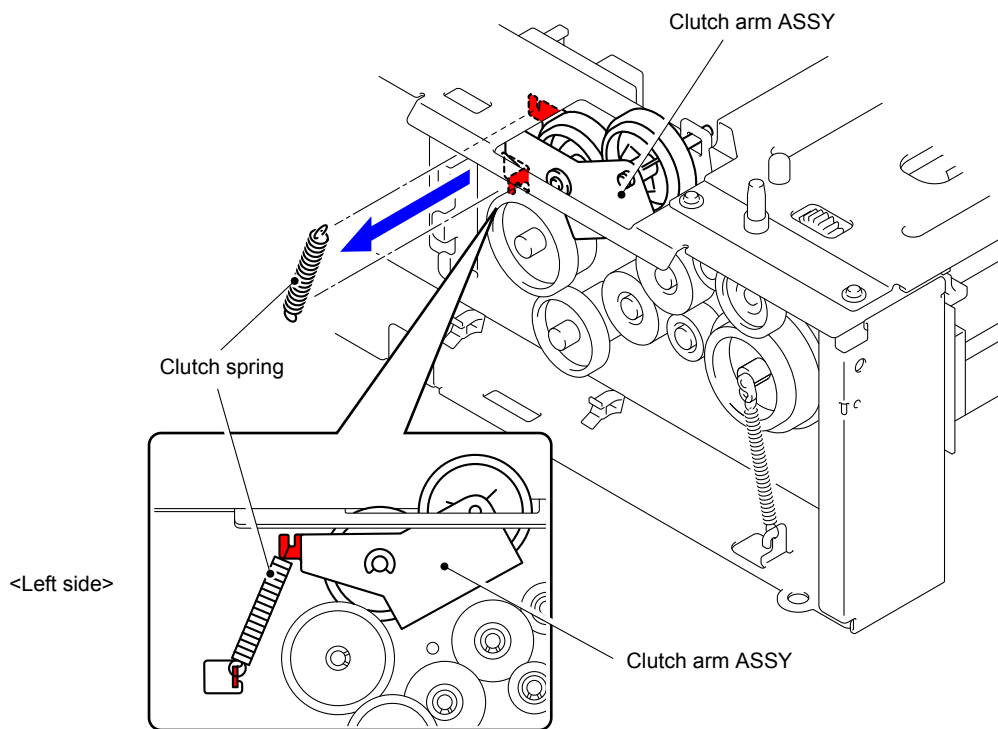

Fig. 3-281

- (2) Release the Hook and remove the Gear 45/40 from the T2 frame L unit.

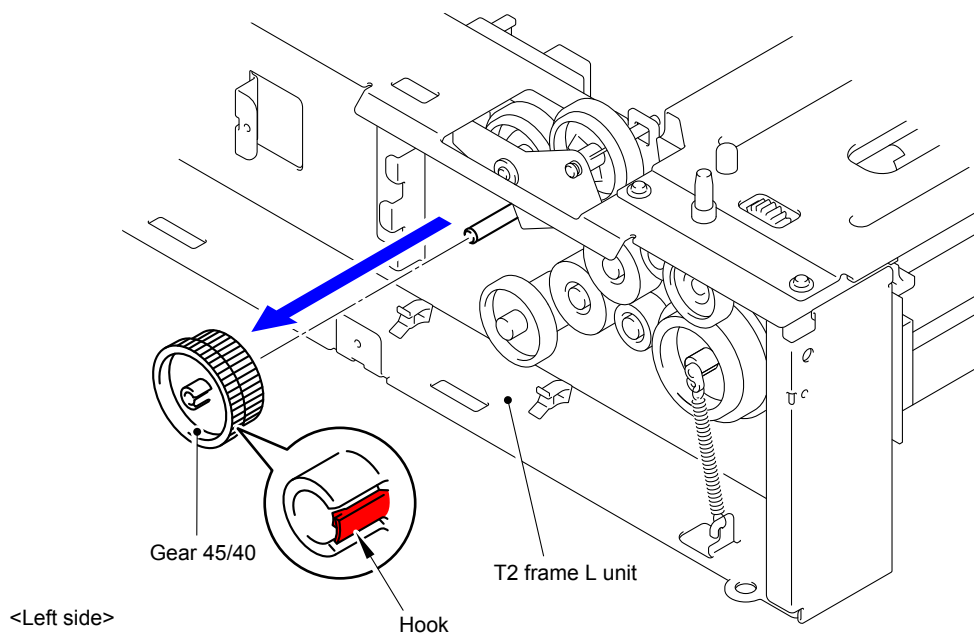

Fig. 3-282

(3) Remove the Collar 6 from the Clutch arm ASSY.

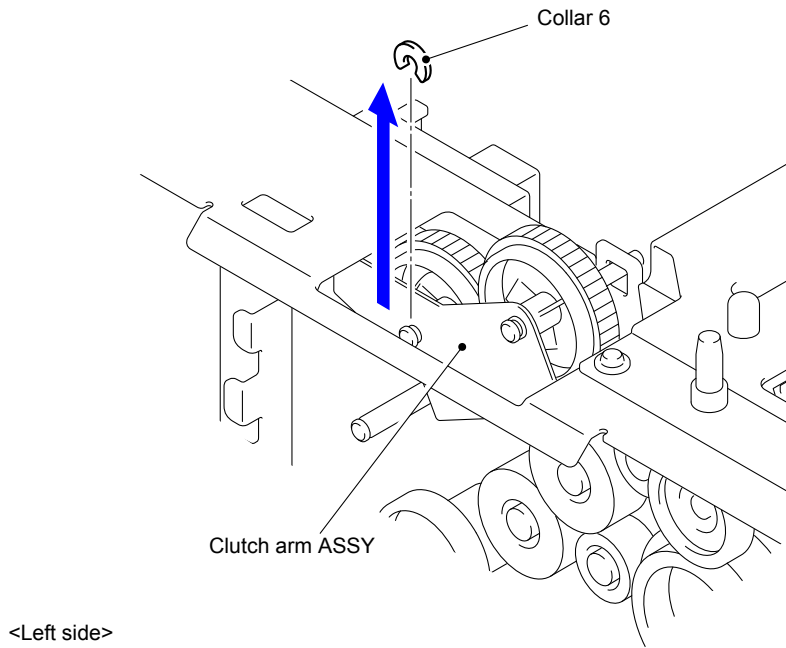

Fig. 3-283

(4) Remove the Clutch arm ASSY from the T2 frame L unit.

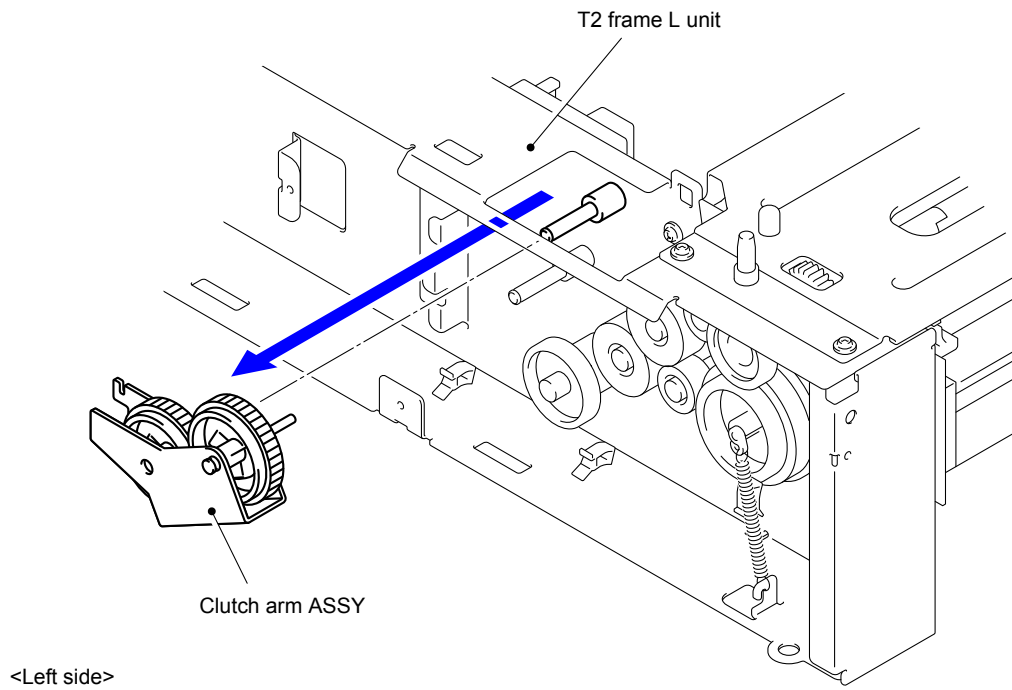

Fig. 3-284

- (5) Remove the five Taptite cup S M3x6 SR screws and remove the T2 beam F ASSY from the Main body.

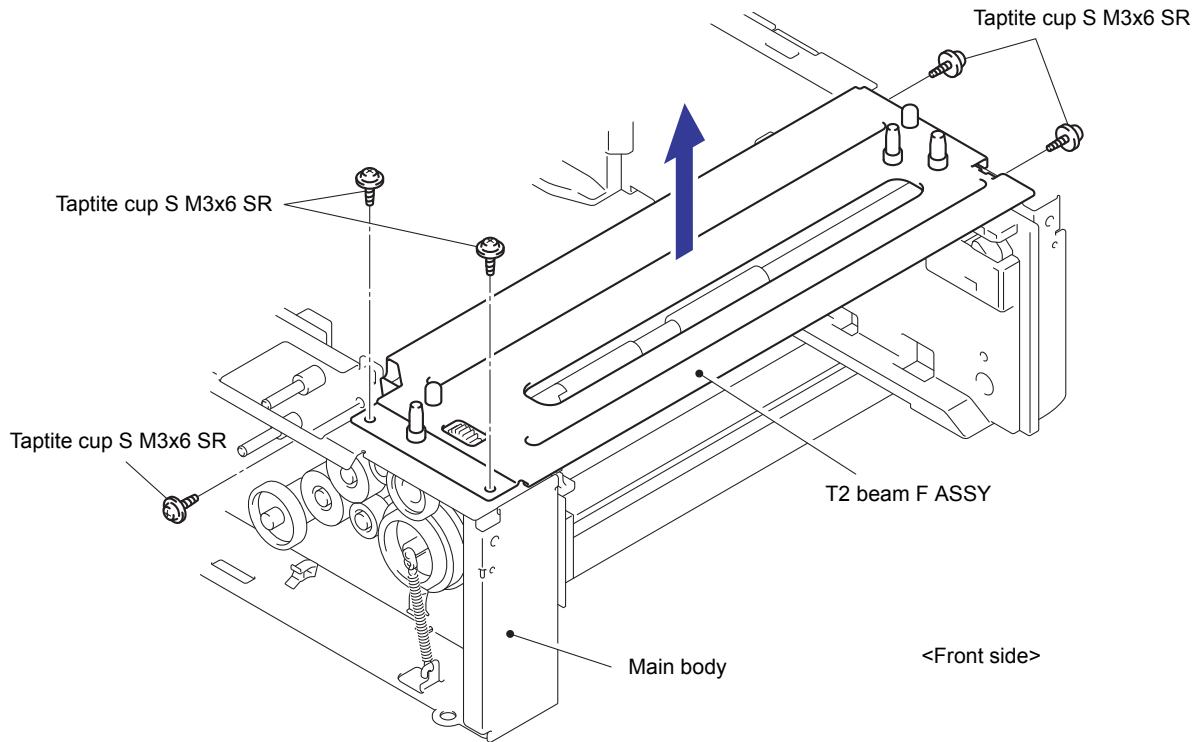

Fig. 3-285

- (6) Remove the Retaining ring E4 from the Feed roller and remove the Gear 24 and Feed roller bushing.

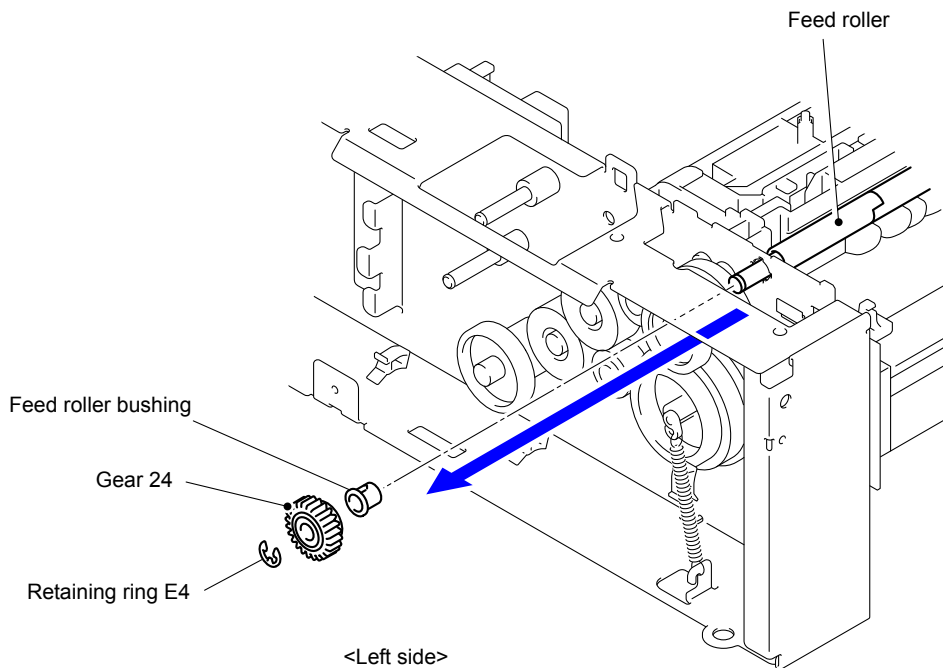

Fig. 3-286

- (7) Remove the Retaining ring E3 from the Feed roller and remove the Feed roller bushing TR.

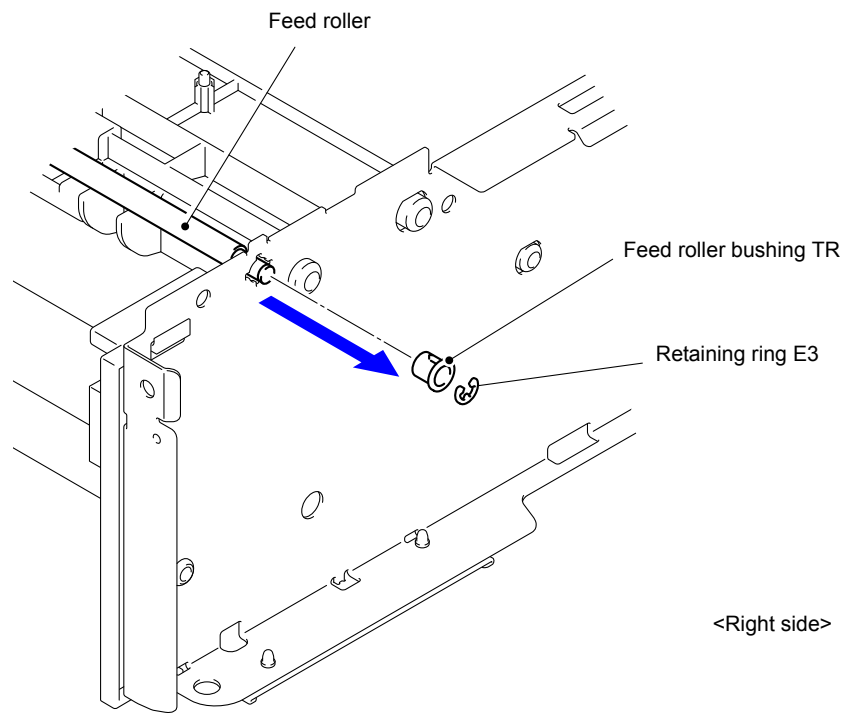

Fig. 3-287

- (8) Remove the Lift spring from the Hook of the Lift lever A.
- (9) Remove the Feed roller from the Main body in the directions of the arrows 9a, 9b, and 9c in this order.

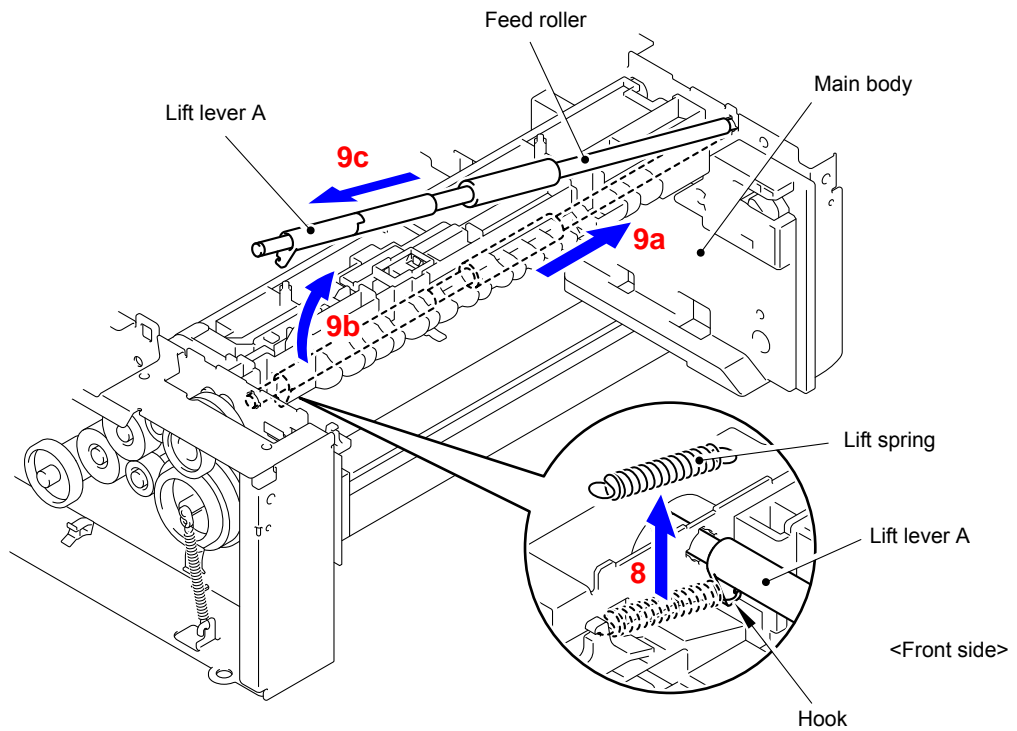

Fig. 3-288

Assembling Note:

When assembling the Feed roller, be sure to assemble it in a way that the Rib of the T2 paper feed frame unit comes between "A" and "B" of the Lift lever B, and the lever of the T2 paper feed holder comes in front of "B".

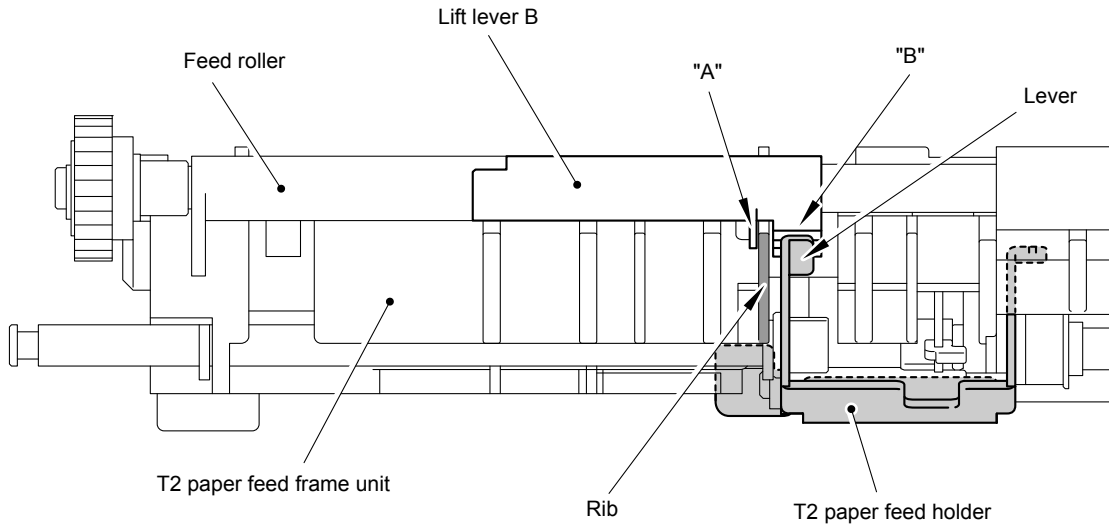

Fig. 3-289

(10) Release the Hook and remove the Gear 20A from the T2 frame L unit.

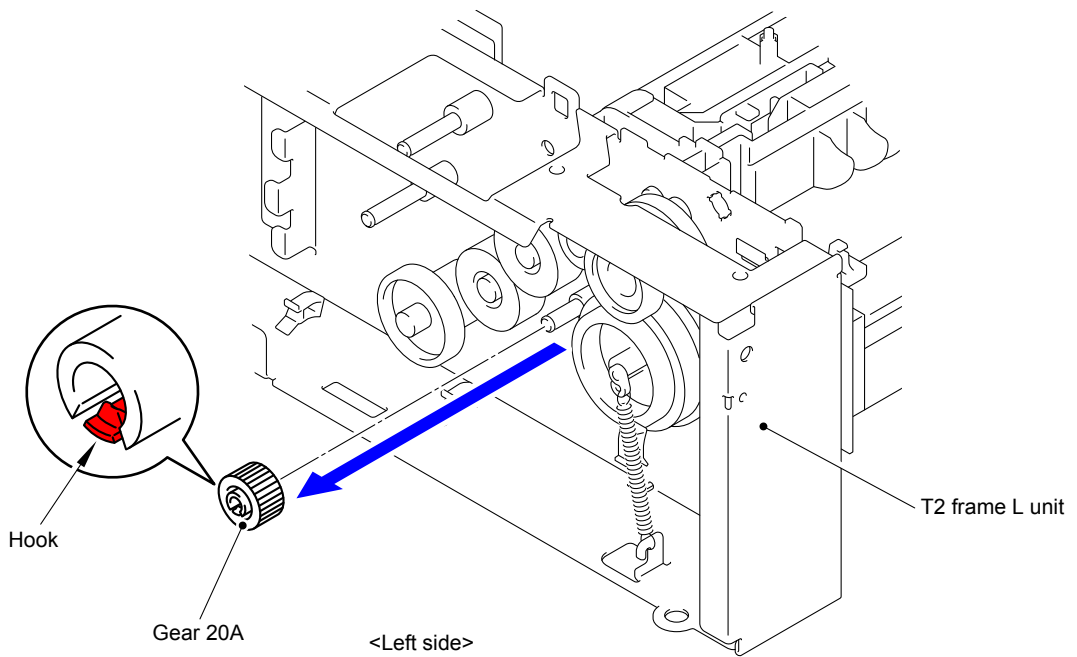

Fig. 3-290

(11) Release the Hook and remove the Gear 33 from the T2 frame L unit.

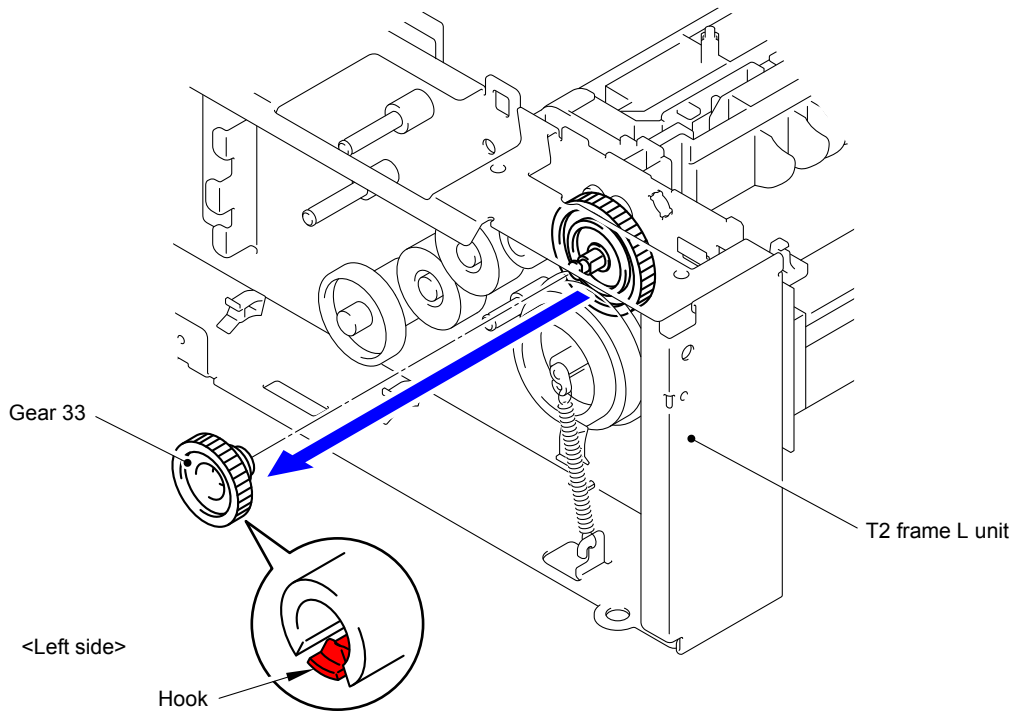

Fig. 3-291

(12) Remove the Extension spring from the Spring hook.

(13) Release the Hook and remove the Gear 46/55 from the T2 frame L unit.

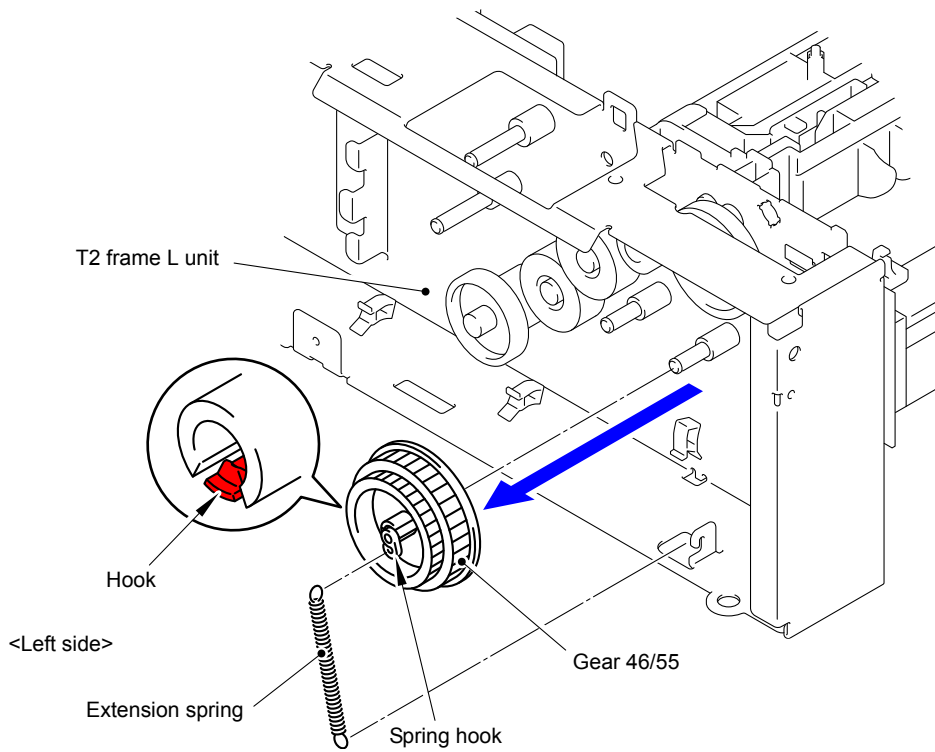

Fig. 3-292

- (14) Remove the Taptite cup S M3x6 SR screw and remove the T2 solenoid holder ASSY from the T2 frame L unit.
- (15) Remove the Gear 46 from the T2 frame L unit.

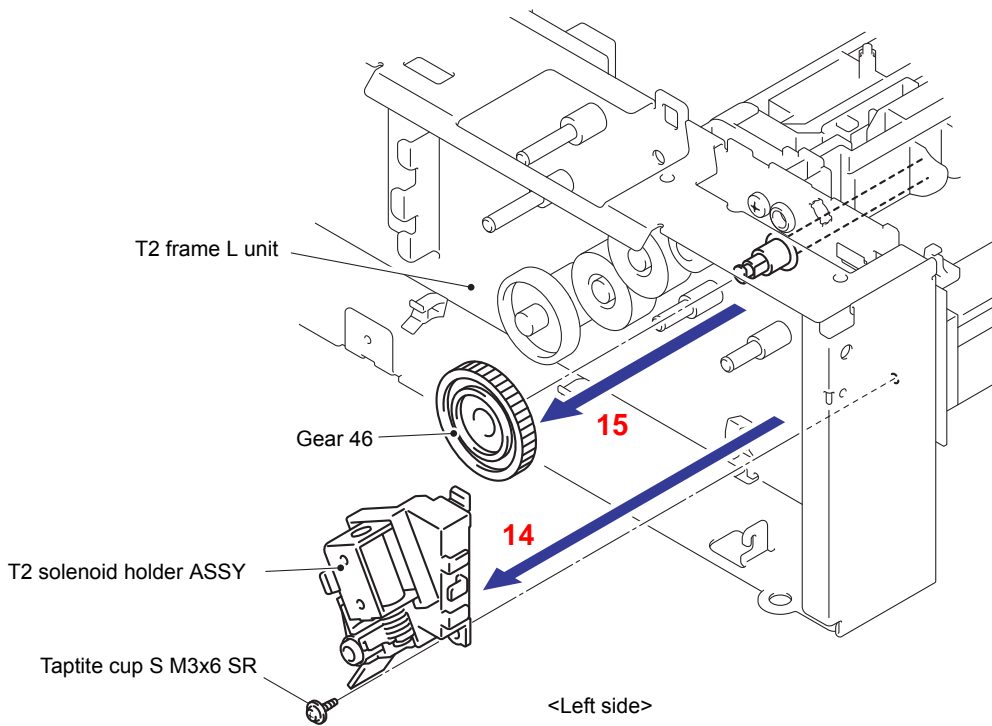

Fig. 3-293

- (16) Turn the T2 frame L unit upside down.
- (17) Remove the two Taptite cup S M3x6 SR screws from the T2 beam front.

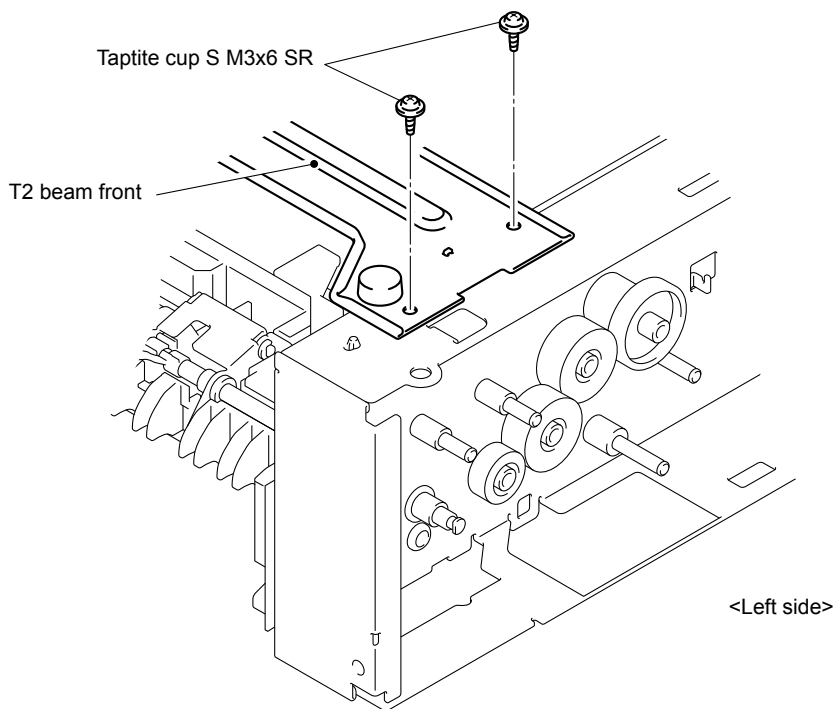

Fig. 3-294

(18) Turn the T2 frame L unit right side up.

(19) Remove the two Taptite cup S M3x6 SR screws from the T2 beam rear.

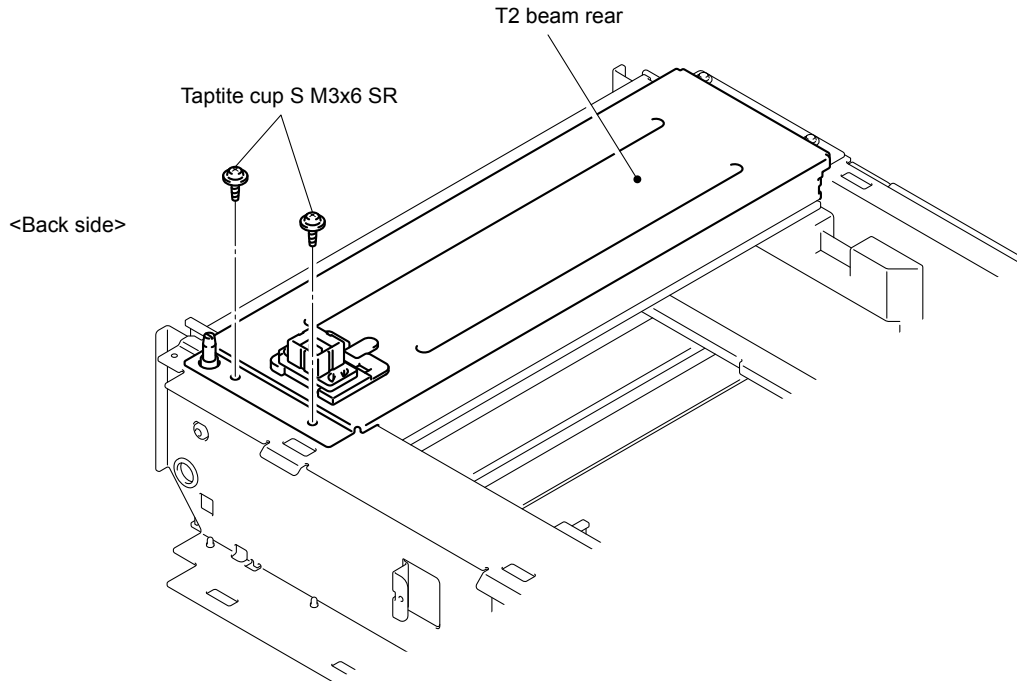

Fig. 3-295

(20) Remove the two Taptite cup S M3x6 SR screws from the T2 beam rear.

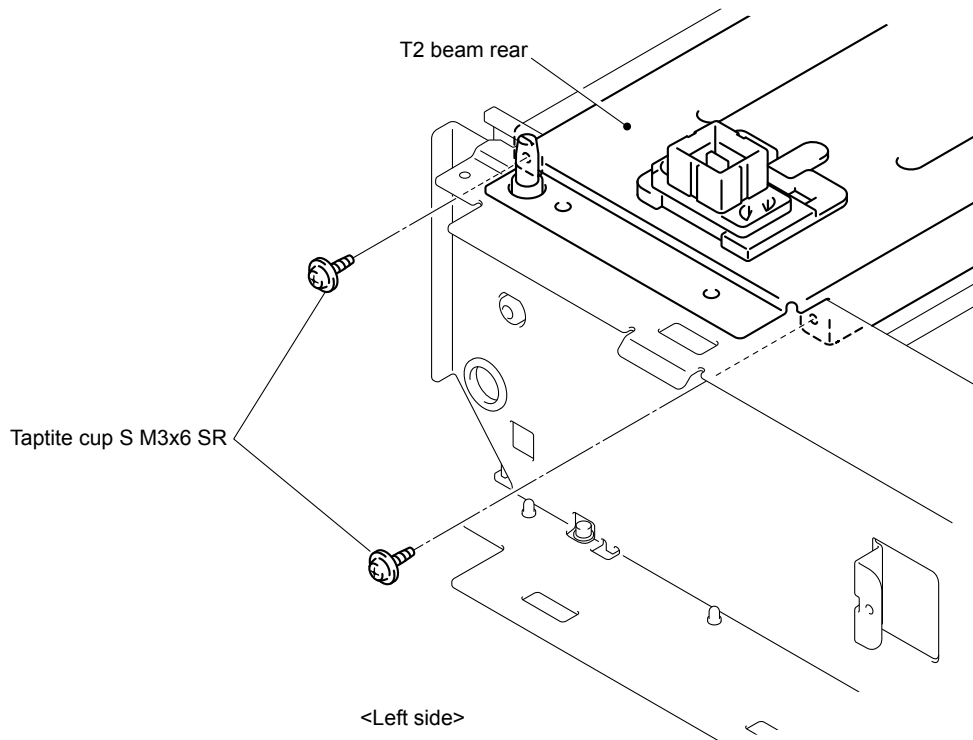

Fig. 3-296

(21) Remove the Taptite bind B M4x10 screw and Bush from the T2 frame L unit.

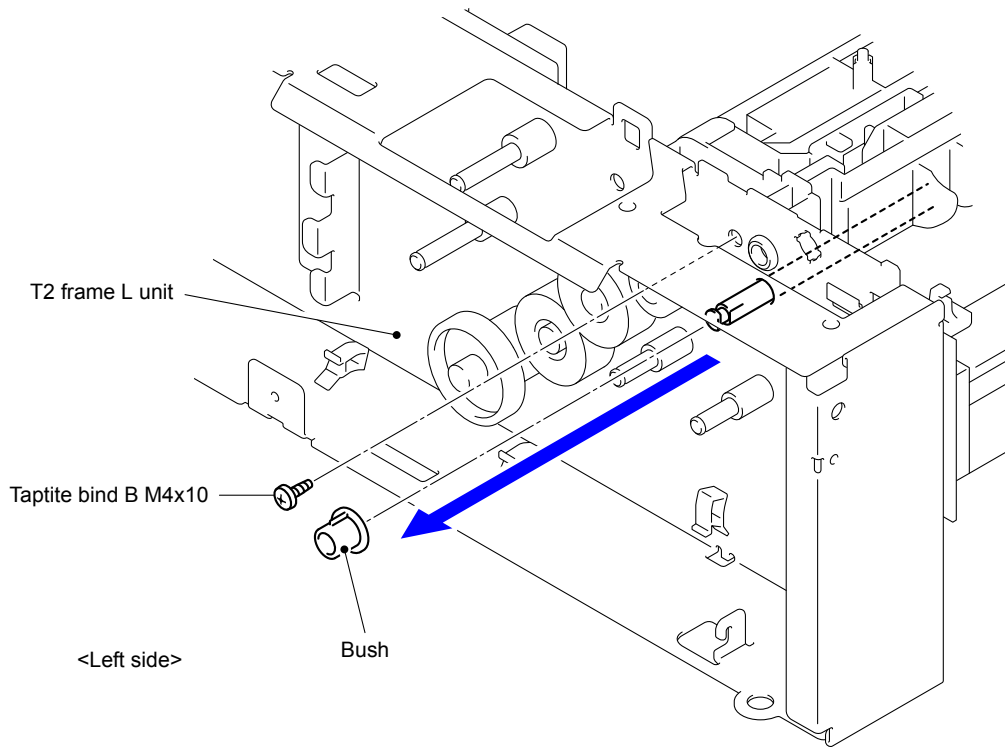

Fig. 3-297

(22) Remove the T2 paper feed frame unit from the Main body in the order of the arrow 22a and arrow 22b.

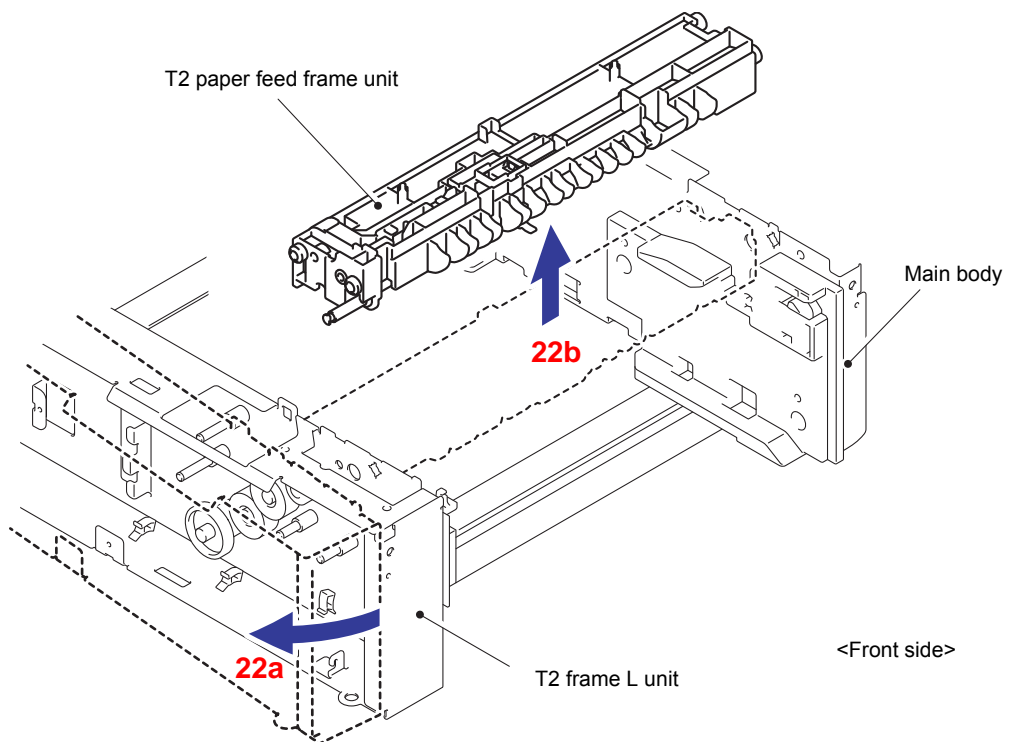

Fig. 3-298

- (23) Release the Hook and slide the T2 separation roller ASSY in the direction of the arrow.
- (24) Rotate the T2 separation roller ASSY in the direction of the arrow 24a. Remove the T2 separation roller ASSY from the T2 paper feed drive shaft in the direction of the arrow 24b.

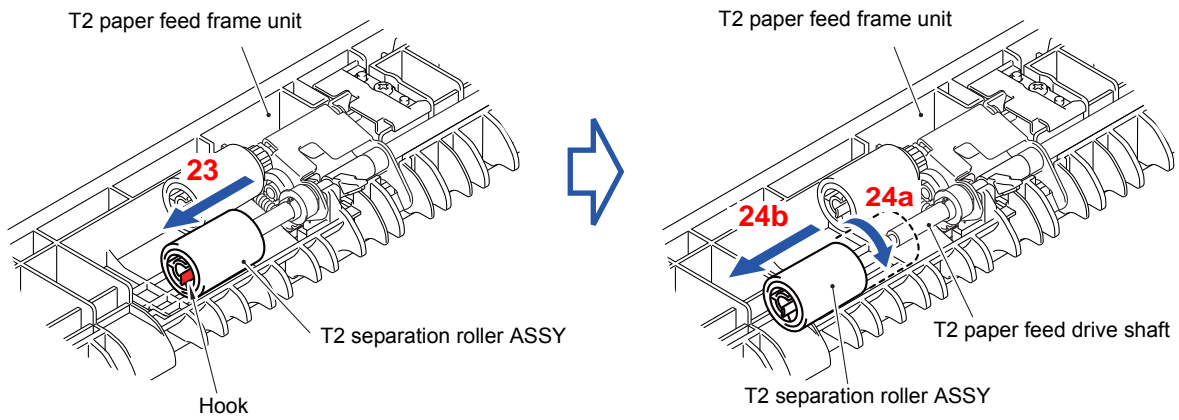

Fig. 3-299

Assembling Note:

When assembling the T2 separation roller ASSY, assemble it by sliding it in the direction of the arrow b as rotating the T2 separation roller ASSY in the direction of the arrow a.

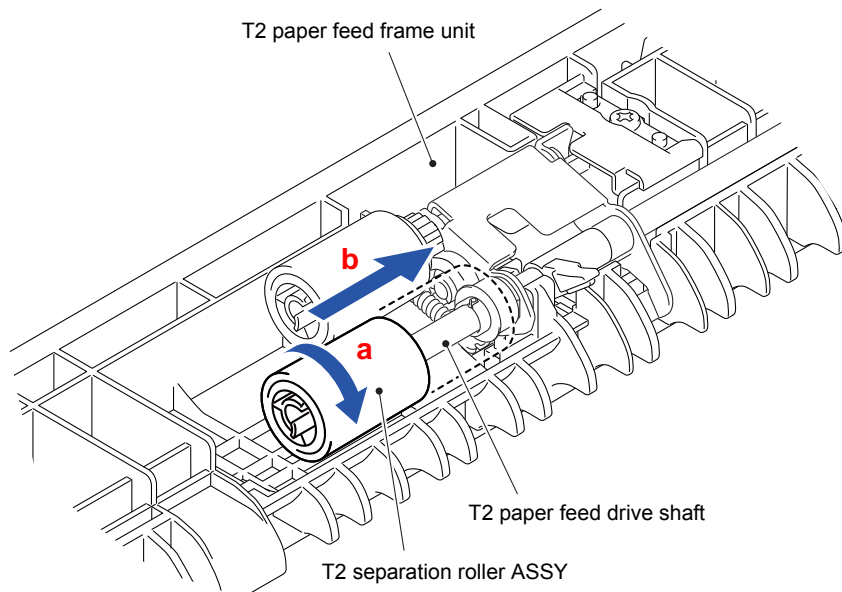

Fig. 3-300

(25) Release the Hook and remove the T2 paper pick-up roller ASSY from the T2 paper feed drive shaft.

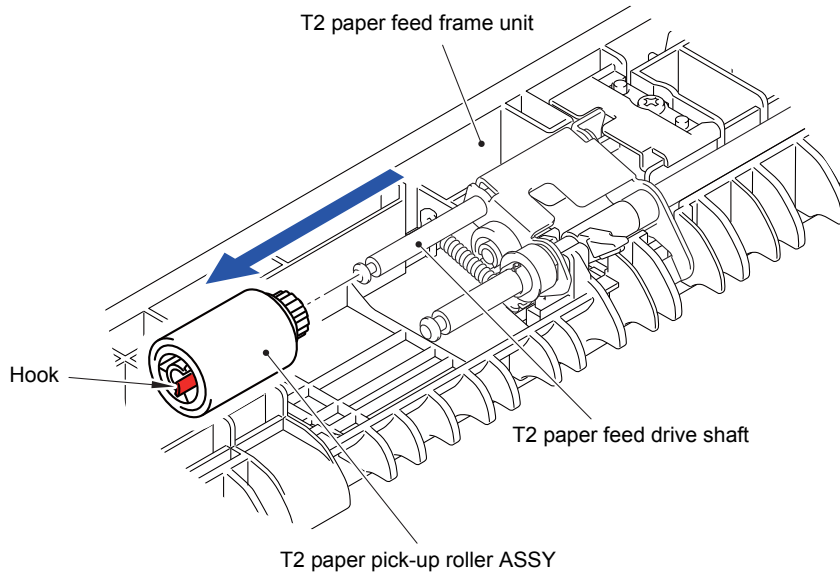

Fig. 3-301

(26) Remove the "A" of the T2 edge actuator spring from the Hook of the T2 paper feed frame unit.

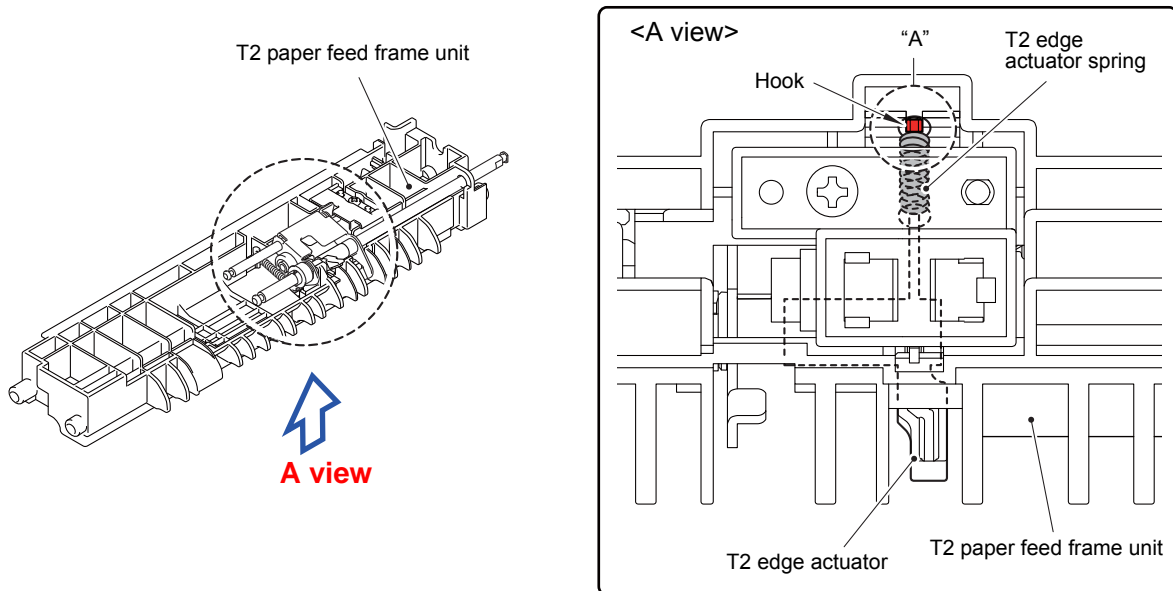

Fig. 3-302

(27) Remove the T2 paper feed spring from the Hook of the T2 paper feed frame unit and the Hook of the T2 paper feed holder ASSY.

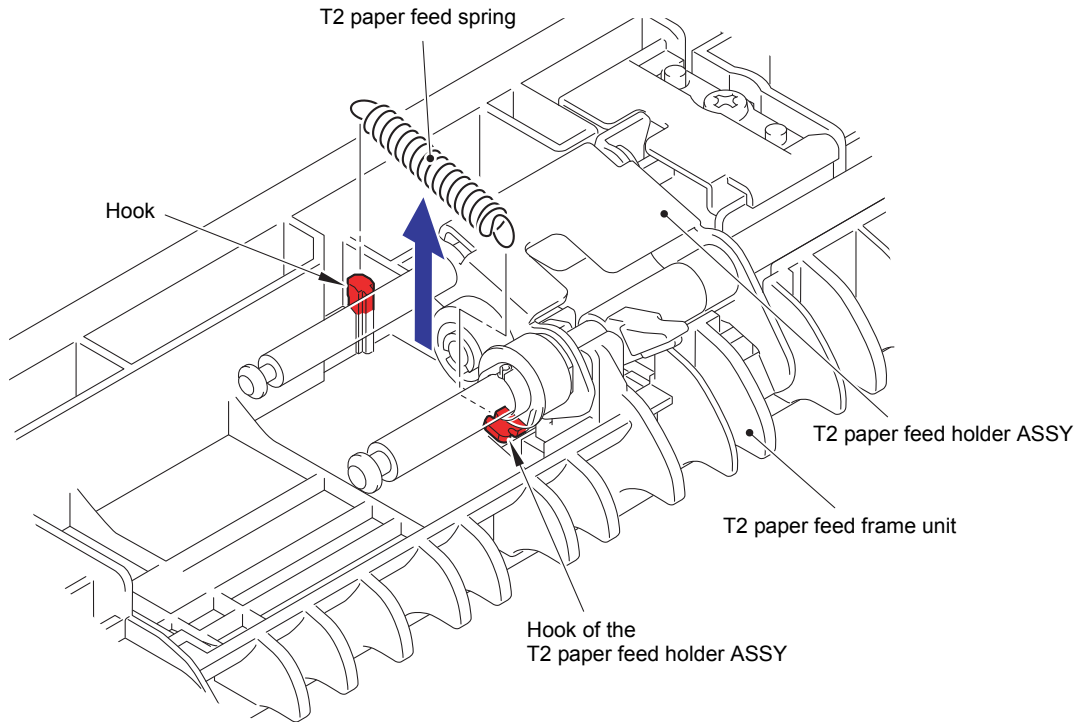

Fig. 3-303

(28) Remove the two Collar 6s from the T2 paper feed drive shaft.

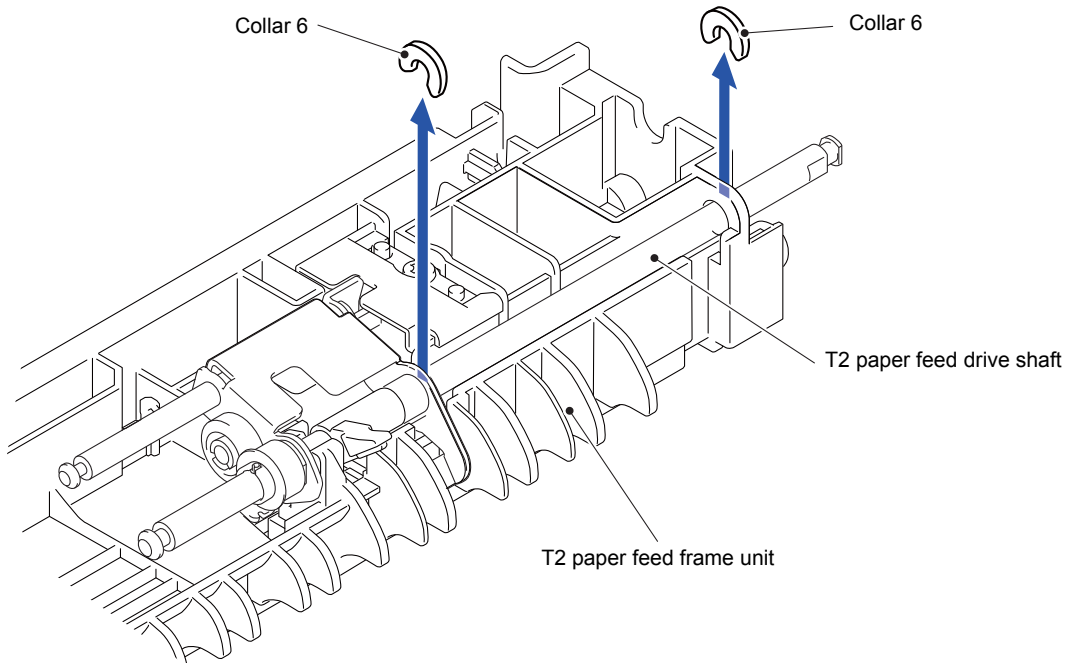

Fig. 3-304

(29) Slide the T2 paper feed drive shaft in the direction of the arrow 29a and remove the T2 paper feed holder bushing from the T2 paper feed holder ASSY.

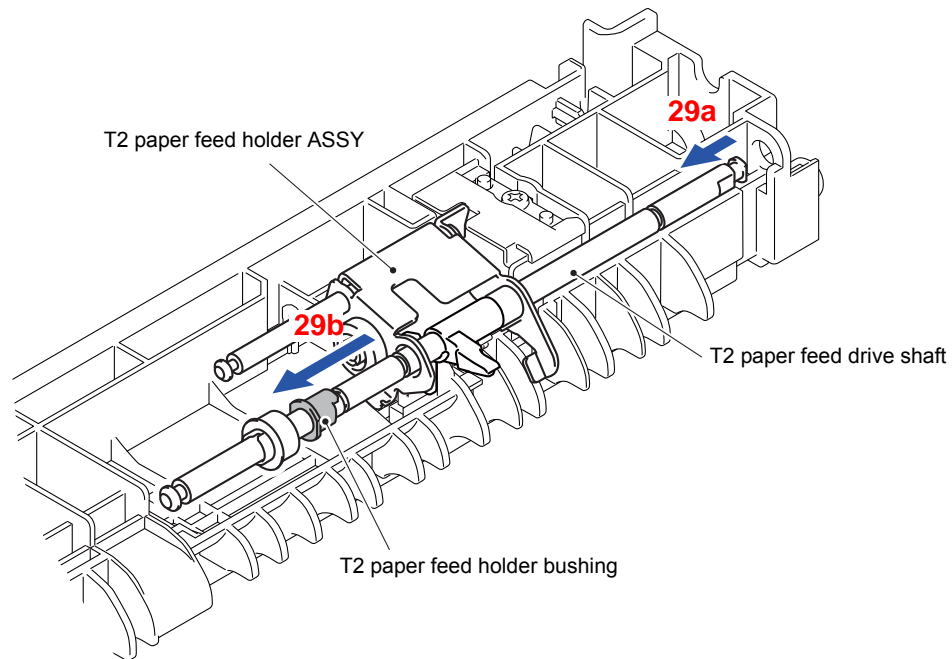

Fig. 3-305

(30) Remove the T2 paper feed holder ASSY and T2 paper feed drive shaft from the T2 paper feed frame unit.

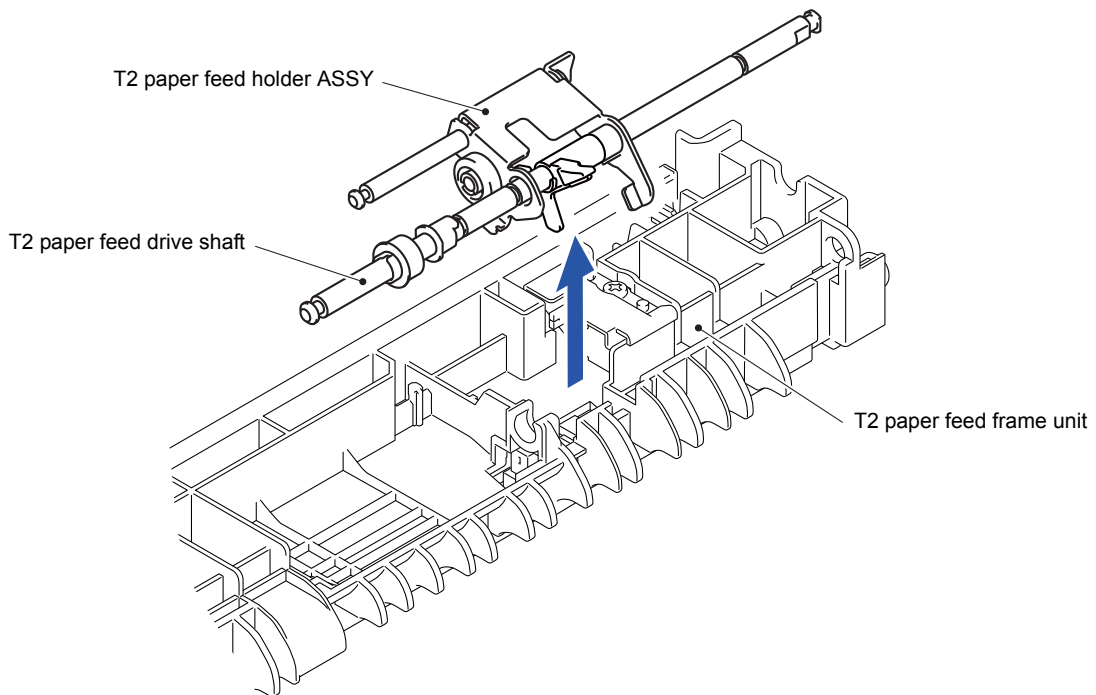

Fig. 3-306

- (31) Pull out the T2 paper feed drive shaft from the T2 paper feed holder ASSY and T2 edge actuator.
- (32) Remove the T2 edge actuator from the T2 paper feed holder ASSY.

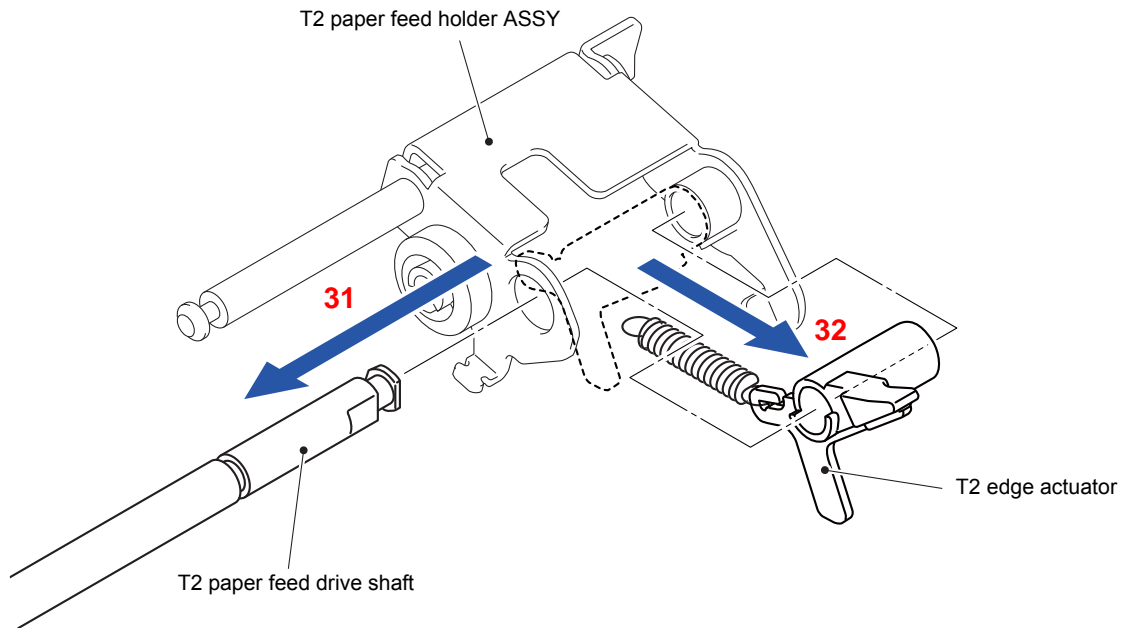

Fig. 3-307

- (33) Remove the T2 edge actuator spring from the Hook of the T2 edge actuator.

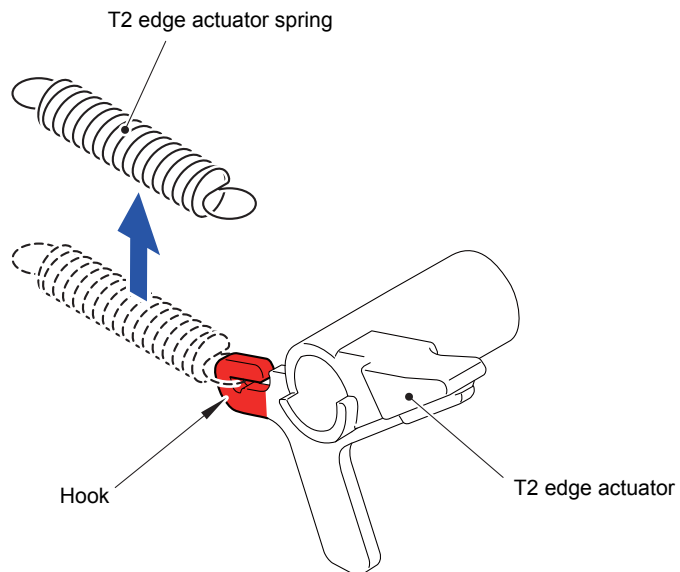

Fig. 3-308

CHAPTER 4 ADJUSTMENTS AND UPDATING OF SETTINGS, REQUIRED AFTER PARTS REPLACEMENT

1. IF YOU REPLACE THE MAIN PCB ASSY

■ What to do after replacement

- Installing the Firmware (Sub firmware, Panel firmware, Main Firmware, and High-voltage firmware)
- Initializing the EEPROM of the Main PCB ASSY (Function code 01)
- Setting the Serial Number (Function code 80)
- Restore Machine Information (Function code 41)
- Setting by Country (Function code 74)
- Motor Reset (Function code 57)
- Continuous Adjustments of Density and Registration Sensor (Function code 73)
- Acquisition of White Level Data (Function code 55)
- Adjustment of Touch Panel (Function code 61)
- Restoration of States at Factory Shipment

■ What you need to prepare

- (1) USB flash memory
- (2) A USB cable
- (3) Create a temporary folder on the C drive of the computer (Windows® XP or higher).
- (4) Service setting tool (BrUsbsn.zip)
Copy it into the temporary folder that has been created in the C drive. Extract the copied file and execute "BrUsbsn.exe" file by double-clicking it.
- (5) Download utility (Filedg32.exe)
Copy it into the temporary folder that has been created in the C drive.
- (6) Maintenance printer driver (Maintenance_driver.zip)
When the maintenance printer driver is not installed, copy this file into the temporary folder created on the C drive, and extract the copied file. Refer to "APPENDIX 3 INSTALLING THE MAINTENANCE PRINTER DRIVER" to install the driver.
- (7) Firmware

Sub firmware	LZXXXX_\$.djf
Panel firmware	LZXXXX_\$.djf
Main firmware	LZXXXX_\$.djf
High-voltage firmware	LZXXXX_\$.djf
LZXXXX: First six digits of the part number of the firmware \$: Alphabet representing the revision of the firmware.	

- (8) Touch pen

1.1 Installing the Firmware (Sub Firmware, Panel Firmware, Main Firmware, and High-voltage Firmware)

1.1.1 Checking firmware version

Check whether the firmware installed in the machine is the latest version. If the version is the latest, updating the firmware is unnecessary. If the version is not the latest, install the latest firmware into the machine following the instructions provided in [“1.1.2 Installing the firmware” in this chapter](#).

<How to check firmware version>

- (1) Hold down the **Home** key for about 5 seconds while the machine is in the ready state.

Memo:

If you cannot find the **Home** key, press the **Toner** key, and the **Home** key lights up.



- (2) Hold down the blank space at the bottom of the LCD for about 2 seconds.
- (3) Press the *, **2**, **8**, **6**, and **4** keys on the LCD in this order to enter the maintenance mode.
- (4) Press the **2** and **5** keys in this order. Then, the Main firmware version information is displayed on the LCD.
- (5) Next, press the **Mono Start** key to display the version information of the Sub firmware, Panel firmware, and High-voltage firmware on the LCD and check the information.

Memo:

You can check the firmware version of the Sub firmware, Panel firmware, Main firmware, and High-voltage firmware by printing the maintenance information.

(Refer to [“1.3.31 Printout of maintenance information \(Function code 77\)” in Chapter 5](#).)

1.1.2 Installing the firmware

■ Installing the firmware using USB flash memory

Memo:

- Installing the firmware using a USB flash memory is not possible in deep sleep mode. Open and close the front cover, etc. to quit the deep sleep mode before installing the firmware.
- Install the Sub firmware, Panel firmware, Main firmware, and High-voltage firmware in this order.
- Never disconnect the AC cord of the machine or computer, or the USB flash memory during installing.
- If installing the firmware using a USB flash memory fails and an error message is displayed on the LCD or no characters are displayed on the LCD, install the firmware using a computer referring to "■ Installing the firmware using computer" in this chapter.

<Operating procedure>

- (1) Save the program files (such as LZXXXX_\$.djf) which are necessary for installing the firmware to the USB flash memory.
- (2) While the machine is in the ready state, connect the USB flash memory drive to the USB direct interface on the front of the machine.
- (3) When the machine detects the USB flash memory, the program names are displayed on the LCD. Press the ▲ or ▼ key to display the program name that you want to install.
- (4) Press the program name that you want to install on the LCD to start installing.
- (5) When installation is completed, the machine automatically restarts.
- (6) Repeat steps (3) to (4) to install necessary firmware.
- (7) When all firmware installation has been completed, remove the USB flash memory from the USB direct interface.

■ Installing the firmware using computer

Memo:

- Install the Sub firmware, Panel firmware, Main firmware, and High-voltage firmware in this order.
- Never disconnect the AC cord of the machine or computer, or the USB cable during installing.
- If you failed to install the firmware, turn OFF the power of the machine and turn it ON again. The machine automatically enters the firmware installing mode. Perform the following installing procedures again.

<Operating procedure>

- (1) If the computer and machine are connected with an USB cable, disconnect the USB cable and enter the maintenance mode. (Refer to [“1.1 How to Enter the Maintenance Mode” in Chapter 5.](#))
- (2) Connect the computer to the machine with the USB cable.
- (3) Open the temporary folder, double-click the “Filedg32.exe” to start, and select “Brother Maintenance USB Printer”.
- (4) Drag and drop a necessary program file (for instance, LZXXXX_\$.djf) located in the same folder to the Brother Maintenance USB Printer icon located within the FILEDG32 screen. The files are sent to the machine and installation into the flash ROM is started.
- (5) When installation is completed, the machine reboots and returns to the ready state.
- (6) Turn OFF the power of the machine, and repeat steps (1) to (5) to install necessary firmware.
- (7) Turn OFF the power of the machine, and disconnect the USB cable.

1.2 Initializing the EEPROM of the Main PCB ASSY (Function code 01)

Initialize the EEPROM of the main PCB ASSY in accordance with [“1.3.1 EEPROM parameter initialization \(Function code 01, 91\)” in Chapter 5.](#)

1.3 Setting the Serial Number (Function code 80)

Referring to “1.3.33 Display of device log information (Function code 80)” in Chapter 5, set the serial number. The serial number can be also set using the service setting tool (BrUsbsn.exe). The procedures are described below.

<Operating procedure>

- (1) Enter the maintenance mode. (Refer to “1.1 How to Enter the Maintenance Mode” in Chapter 5.)
- (2) Connect the computer to the machine with the USB cable.
- (3) Double-click the “BrUsbsn.exe” file copied into the temporary folder to start the file. The BrUsbsn screen appears as shown on the right.
- (4) Select “3 Color-Laser” in [Product Category] field.
- (5) Select “2014_MFC”.
- (6) In [Port] field on the BrUsbsn screen, select the port assigned to Brother Maintenance USB Printer.
- (7) Enter the serial number (15 digits) of the machine into the box on the [Serial No] field.
- (8) Click the **OK** button. The serial number is written in the machine.
- (9) Turn OFF the power of the machine, and disconnect the USB cable from the computer and the machine.

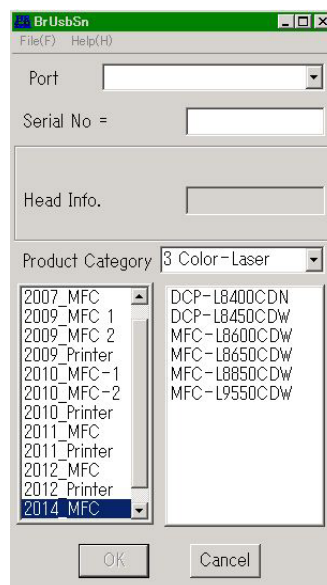

Memo:

Refer to “APPENDIX 1 SERIAL NUMBERING SYSTEM” to know how to read the serial number label of the machine.

1.4 Restore Machine Information (Function code 41)

Restore the machine information and user setting information that have been backed up in an external memory in accordance with “1.3.13 Backup of machine information (Function code 41)” in Chapter 5.

Memo:

If the data is successfully restored, the operations described in sections 1.5 to 1.7 in this chapter are not necessary. If backup data is unavailable or you fail to restore backup data, proceed to the operations described in sections 1.5 to 1.7 in this chapter.

1.5 Setting by Country (Function code 74)

Make appropriate settings by country in accordance with “1.3.30 Setting by country (Function code 74)” in Chapter 5.

1.6 Motor Reset (Function code 57)

Perform motor reset in accordance with “1.3.20 Motor reset (Function code 57)” in Chapter 5.

1.7 Continuous Adjustments of Density and Registration Sensor (Function code 73)

Perform continuous adjustments of density and registration sensor in accordance with “1.3.29 Continuous adjustments of density and registration sensor (Function code 73)” in Chapter 5.

1.8 Acquisition of White Level Data (Function code 55)

Perform the acquisition of white level data in accordance with “1.3.19 Acquisition of white level data and setting of CIS scanning area (Function code 55)” in Chapter 5.

1.9 Adjustment of Touch Panel (Function code 61)

Perform adjustment of touch panel in accordance with “1.3.21 Adjustment of touch panel (Function code 61)” in Chapter 5.

1.10 Restoration of States at Factory Shipment

<Operating procedure>

- (1) Hold down the **Home** key for about 5 seconds while the machine is in the ready state. The screen shown below is displayed on the LCD.

Memo:

If you cannot find the **Home** key, press the **Toner** key, and the **Home** key lights up.

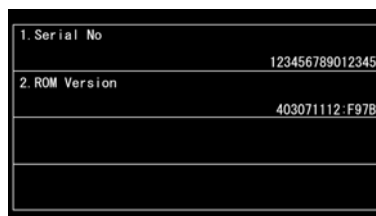

- (2) Hold down the blank space at the bottom of the LCD for about 2 seconds. The screen shown below is displayed on the LCD.



- (3) Press the *, **1**, **9**, **3**, and **7** keys on the LCD in this order.
- (4) Press the **0**, **0**, **8**, and **4** keys on the LCD in this order.
- (5) Press the **▲** or **▼** key to display “FUNC_DISABLE” on the LCD.
- (6) Press the **SET** key. The function selection at startup is disabled.
- (7) Press the **9** key twice to return the machine to the ready state.

Note:

If these procedures are not performed, the machine enters the function selection mode at startup by holding down the Power key, and the general operation of the machine becomes unavailable.

2. IF YOU REPLACE THE REGISTRATION MARK SENSOR UNIT

■ What to do after replacement

- Continuous Adjustments of Density and Registration Sensor (Function code 73)

2.1 Continuous Adjustments of Density and Registration Sensor (Function code 73)

Perform continuous adjustments of density and registration sensor in accordance with “[1.3.29 Continuous adjustments of density and registration sensor \(Function code 73\)](#)” in Chapter 5.

3. IF YOU REPLACE THE LOW-VOLTAGE POWER SUPPLY PCB UNIT

■ What to do after replacement

- Reset of Irregular Power Supply Detection Counter of Low-Voltage Power Supply PCB (Reset Counters for Parts (Function code 88))

3.1 Reset of Irregular Power Supply Detection Counter of Low-Voltage Power Supply PCB (Reset Counters for Parts (Function code 88))

Perform resetting irregular power supply detection counter of the low-voltage power supply PCB in accordance with [“1.3.37 Reset counters for parts \(Function code 88\)”](#) in Chapter 5.

4. IF YOU REPLACE THE PROCESS DRIVE UNIT

■ What to do after replacement

- Motor Reset (Function code 57)

4.1 Motor Reset (Function code 57)

Perform motor reset in accordance with [“1.3.20 Motor reset \(Function code 57\)”](#) in Chapter 5.

5. IF YOU REPLACE THE HIGH-VOLTAGE POWER SUPPLY PCB ASSY

■ What to do after replacement

- Installing the Firmware
- Continuous Adjustments of Density and Registration Sensor (Function code 73)

■ What you need to prepare

- (1) USB flash memory
- (2) A USB cable
- (3) Create a temporary folder on the C drive of the computer (Windows® XP or higher).
- (4) Service setting tool (BrUsbsn.zip)
Copy it into the temporary folder that has been created in the C drive. Extract the copied file and execute “BrUsbsn.exe” file by double-clicking it.
- (5) Download utility (Filedg32.exe)
Copy it into the temporary folder that has been created in the C drive.
- (6) Maintenance printer driver (Maintenance_driver.zip)
When the maintenance printer driver is not installed, copy this file into the temporary folder created on the C drive, and extract the copied file. Refer to **“APPENDIX 3 INSTALLING THE MAINTENANCE PRINTER DRIVER”** to install the driver.
- (7) Firmware

Sub firmware	LZXXXX_\$.djf
Panel firmware	LZXXXX_\$.djf
Main firmware	LZXXXX_\$.djf
High-voltage firmware	LZXXXX_\$.djf
LZXXXX: First six digits of the part number of the firmware \$: Alphabet representing the revision of the firmware.	

5.1 Installing the Firmware

5.1.1 Checking firmware version

Check whether the firmware installed on the machine is the latest version in accordance with **“1.1.1 Checking firmware version” in this chapter**. If the version is the latest, installing the firmware is unnecessary. If the version is not the latest, install all the firmwares.

5.1.2 Installing the firmware

When each installed firmware is not the latest version, install the firmwares in accordance with **“1.1.2 Installing the firmware” in this chapter**.

5.2 Continuous Adjustments of Density and Registration Sensor (Function code 73)

Perform continuous adjustments of density and registration sensor in accordance with **“1.3.29 Continuous adjustments of density and registration sensor (Function code 73)” in Chapter 5**.

6. IF YOU REPLACE THE LCD PANEL ASSY OR PANEL CONTROL PCB ASSY

■ What to do after replacement

- Installing the Firmware
- Adjustment of Touch Panel (Function code 61)
- Operational Check of LCD (Function code 12)

■ What you need to prepare

- (1) USB flash memory
- (2) A USB cable
- (3) Create a temporary folder on the C drive of the computer (Windows® XP or higher).
- (4) Download utility (Filedg32.exe)
Copy it into the temporary folder that has been created in the C drive.
- (5) Maintenance printer driver (Maintenance_driver.zip)
When the maintenance printer driver is not installed, copy this file into the temporary folder created on the C drive, and extract the copied file. Refer to **"APPENDIX 3 INSTALLING THE MAINTENANCE PRINTER DRIVER"** to install the driver.
- (6) Firmware

Sub firmware	LZXXXX_\$.djf
Panel firmware	LZXXXX_\$.djf
Main firmware	LZXXXX_\$.djf
High-voltage firmware	LZXXXX_\$.djf
LZXXXX: First six digits of the part number of the firmware \$: Alphabet representing the revision of the firmware.	

- (7) Touch pen

6.1 Installing the Firmware

6.1.1 Checking firmware version

Check whether the firmware installed on the machine is the latest version in accordance with **"1.1.1 Checking firmware version" in this chapter**. If the version is the latest, installing the firmware is unnecessary. If the version is not the latest, install all the firmwares.

6.1.2 Installing the firmware

When each installed firmware is not the latest version, install the firmwares in accordance with **"1.1.2 Installing the firmware" in this chapter**.

6.2 Adjustment of Touch Panel (Function code 61)

Perform adjustment of touch panel in accordance with **"1.3.21 Adjustment of touch panel (Function code 61)" in Chapter 5**.

6.3 Operational Check of LCD (Function code 12)

Perform operation check of the LCD in accordance with **"1.3.6 Operational check of LCD (Function code 12)" in Chapter 5**.

7. IF YOU REPLACE THE LASER UNIT

■ What to do after replacement

- Continuous Adjustments of Density and Registration Sensor (Function code 73)
- Counter Reset of Laser Unit
(Reset Counters for Parts (Function code 88))

7.1 Continuous Adjustments of Density and Registration Sensor (Function code 73)

Perform continuous adjustments of density and registration sensor in accordance with “[1.3.29 Continuous adjustments of density and registration sensor \(Function code 73\)](#)” in Chapter 5.

7.2 Counter Reset of Laser Unit (Reset Counters for Parts (Function code 88))

Perform counter reset of the laser unit in accordance with “[1.3.37 Reset counters for parts \(Function code 88\)](#)” in Chapter 5.

8. IF YOU REPLACE THE FIRST SIDE CIS UNIT, DOCUMENT SCANNER UNIT

■ What to do after replacement

- Acquisition of White Level Data (Function code 55)
- Scanning and Printing Check

8.1 Acquisition of White Level Data (Function code 55)

Perform the acquisition of white level data in accordance with “1.3.19 Acquisition of white level data and setting of CIS scanning area (Function code 55)” in Chapter 5.

8.2 Scanning and Printing Check

Scan the test chart TC-023 for scanning and printing check on the document glass, and make sure there are no problems of the printed image.

Make sure there are no problem of the document scanner unit and the performance of recording part.

9. IF YOU REPLACE THE ADF UNIT, SECOND SIDE CIS UNIT

■ What to do after replacement

- Acquisition of White Level Data (Function code 55)
- Scanning and Printing Check

9.1 Acquisition of White Level Data (Function code 55) (Duplex Scanning Model Only)

Perform the acquisition of white level data in accordance with “1.3.19 Acquisition of white level data and setting of CIS scanning area (Function code 55)” in Chapter 5.

9.2 Scanning and Printing Check

Scan the test chart TC-023 for scanning and printing check with ADF, and make sure there are no problem of the printed image.

Make sure there are no problem of the ADF and the performance of recording part.

10. IF YOU REPLACE THE FUSER UNIT/ PF KIT 1, 2, AND MP

■ What to do after replacement

- Counter Reset of Fuser Unit or PF Kit 1, 2, and MP
(Reset Counters for Parts (Function code 88))

10.1 Counter Reset of Fuser Unit or PF Kit 1, 2, and MP (Reset Counters for Parts (Function code 88))

Perform counter reset of the fuser unit or PF kit 1, 2, and MP in accordance with [“1.3.37 Reset counters for parts \(Function code 88\)”](#) in Chapter 5.

CHAPTER 5 SERVICE FUNCTIONS

1. MAINTENANCE MODE

The maintenance mode is exclusively designed for the checking, setting and adjustments of the machine by using the keys on the control panel. You can check the operations of sensors, perform a print test, display the log information or error codes, and modify the worker switch (WSW).

1.1 How to Enter the Maintenance Mode

1.1.1 How to Enter the Maintenance Mode Exclusive to Service Personnel

<Operating procedure>

- (1) Hold down the **Home** key for about 5 seconds while the machine is in the ready state. The screen shown on the right is displayed on the LCD.

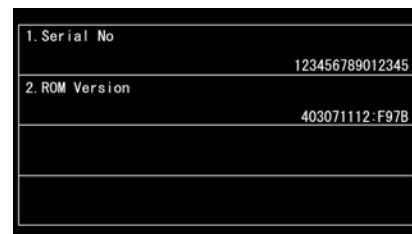

Memo:

If you cannot find the **Home** key, press the **Toner** key, and the **Home** key lights up.



- (2) Hold down the blank space at the bottom of the LCD for about 2 seconds. The screen shown on the right is displayed on the LCD.



- (3) Press the *****, **2**, **8**, **6**, and **4** keys on the LCD in this order. The screen shown on the right is displayed on the LCD and the machine enters the maintenance mode.
- (4) To select one of the maintenance mode functions shown in ["1.2 List of Maintenance-mode Functions"](#), directly enter the function code that you want to use with the ten-key pad.

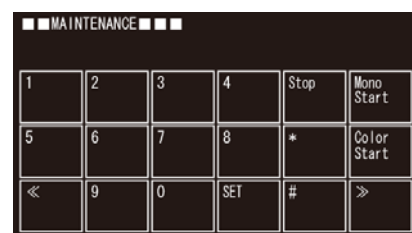

1.1.2 How to Enter the End User-accessible Maintenance Mode

Basically, the maintenance-mode functions listed in the next page should be accessed by service personnel only. However, you can allow end users to access some of these under the guidance of service personnel by phone, for example. The end user-accessible functions are shaded in the table given on "1.2 List of Maintenance-mode Functions". (codes 09, 10, 11, 12, 25, 28, 41, 43, 45, 52, 53, 54, 61, 66, 68, 71, 72, 77, 80, 82, 87 and 91)

<Operating procedure>

- (1) Hold down the **Home** key for about 5 seconds while the machine is in the ready state. The screen shown on the right is displayed on the LCD.

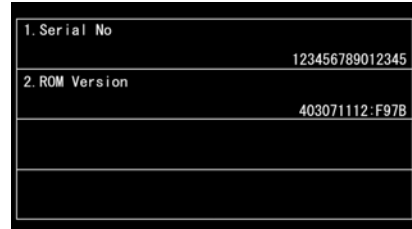

Memo:

If you cannot find the **Home** key, press the **Toner** key, and the **Home** key lights up.



- (2) Hold down the blank space at the bottom of the LCD for about 2 seconds. The screen shown on the right is displayed on the LCD.
- (3) Press the *, 0, and # keys on the LCD in this order. The machine gets ready for the input of a function code. Enter the function code you want to use.
- (4) When each of the maintenance mode functions is completed, the machine automatically returns to the ready state.



1.2 List of Maintenance-mode Functions

Function code	Function	Refer to:
01	EEPROM parameter initialization	1.3.1 (5-5)
05	Printout of scanning compensation data	1.3.2 (5-6)
08	ADF performance test	1.3.3 (5-8)
09	Monochrome image quality test pattern	1.3.4 (5-9)
10	Worker switch (WSW) setting	1.3.5 (5-10)
11	Printout of worker switch (WSW) data	1.3.5 (5-10)
12	Operational check of LCD	1.3.6 (5-14)
13	Operational check of control panel key	1.3.7 (5-15)
25	Software version check	1.3.8 (5-16)
28	“One Push Demo” setting	1.3.9 (5-17)
32	Operational check of sensors	1.3.10 (5-18)
33	LAN connection status display	1.3.11 (5-22)
40	EEPROM Dump Print	1.3.12 (5-23)
41	Backup of machine information	1.3.13 (5-24)
43	PC print function setting	1.3.14 (5-26)
45	Changing return value of USB No./ Switching Dither Pattern/Switching of ON/OFF of DirectPrint Color mode-Improve Gray Color/Switching of timing to execute Auto Registration/ Adjusting left-end print start position on second side in duplex printing/Change of the transfer current setting/ Change of ghost reduction setting	1.3.15 (5-29)
52	Set country/language	1.3.16 (5-33)
53	Transfer of received fax data and log information	1.3.17 (5-34)
54	Fine adjustment of scan positions	1.3.18 (5-36)
55	Acquisition of white level data and setting of CIS scanning area	1.3.19 (5-37)
57	Motor reset	1.3.20 (5-38)
61	Adjustment of touch panel	1.3.21 (5-39)
66	Adjustment of color registration (Adjustment of inter-color position alignment)	1.3.22 (5-40)
67	Continuous print test	1.3.23 (5-44)
68	Laser unit test pattern print	1.3.24 (5-48)
69	Frame pattern print (One-sided)	1.3.25 (5-49)
70	Frame pattern print (Two-sided)	1.3.26 (5-50)
71	Color test pattern	1.3.27 (5-51)
72	Sensitivity adjustment of density sensor	1.3.28 (5-54)

Function code	Function	Refer to:
73	Continuous adjustments of density and registration sensor	1.3.29 (5-55)
74	Setting by country	1.3.30 (5-56)
77	Printout of maintenance information	1.3.31 (5-59)
78	Operational check of fans	1.3.32 (5-61)
80	Display of device log information	1.3.33 (5-62)
82	Display of device error codes	1.3.34 (5-66)
83	Developing bias voltage correction	1.3.35 (5-67)
87	Sending of communication log information to telephone line	1.3.36 (5-68)
88	Reset counters for parts	1.3.37 (5-69)
91	EEPROM parameter initialization	1.3.1 (5-5)
99	Exit from the maintenance mode	1.3.38 (5-69)

* The functions shaded in the table above are user-accessible.

1.3 Detailed Description of Maintenance-mode Functions

1.3.1 EEPROM parameter initialization (Function code 01, 91)

<Function>

This function is used to initialize the setting values for operation parameters, user switches, and worker switches (WSW) registered in the EEPROM. Entering function code 01 initializes most EEPROM areas. Entering function code 91 initializes only the specified areas as shown in the table below.

Data item	Function code 01	Function code 91	
Printer switch (Counter information)	These will not be initialized.	These will not be initialized.	
Error History			
MAC address (Ethernet Address)			
Operation lock of the control panel password	These will be initialized.		
Secure Function Lock			
Telephone function registration/ Telephone book			
Worker switch			
User switches (Items to be initialized when resetting to the factory default settings)			These will be initialized.
Function setting except user switches (Items except the factory default settings) - Languages - Interfaces			
LAN settings			
PCL core area (Emulation settings)			

<Operating procedure>

- (1) Press the **0** and **1** keys (or the **9** and **1** keys according to your need) in this order in the initial state of the maintenance mode.
- (2) Upon completion of parameter initialization, the machine returns to the initial state of the maintenance mode.

Note:

Function code 01 is for service personnel. Function code 91 is for user support.

1.3.2 Printout of scanning compensation data (Function code 05)

<Function>

This function is used to print the contrast level data for document scanning compensation.

<Operating procedure>

Note:

- Be sure to execute this operating procedure not immediately after the power is turned ON, but after conducting the document scanning operation at least once in scanning. Since the machine initializes the brightness level data and obtains the standard value for document scanning compensation when starting scanning the document, the correct data for compensation cannot be printed out even if this operation is implemented without scanning the document.
- The print result varies depending on whether implementing color scanning or black and white scanning immediately before this operating procedure. Make sure the brightness level data you want to print and implement the operation below.

- (1) For white and black scanning, copy the document. For color scanning, implement color copy of the document.
- (2) Press the **0** and **5** keys in this order in the initial state of the maintenance mode. The "1. FRONT 2. BACK?" will appear on the LCD.
- (3) When you press the **1** or **2** key, the message "PRINTING" appears on the LCD and the machine prints the list of the data for document scanning compensation including the following data.

Note:

If there is no paper in the paper tray, the print job is canceled.

- (4) When printing is finished, the machine returns to the initial state of the maintenance mode.

■ Output data (for both monochrome and color)

a)	LED pulse data 1 (UP) (G)	2 Byte
b)	LED pulse data 1 (DOWN) (G)	2 Byte
c)	LED pulse data 1 (UP) (B)	2 Byte
d)	LED pulse data 1 (DOWN) (B)	2 Byte
e)	LED pulse data 1 (UP) (R)	2 Byte
f)	LED pulse data 1 (DOWN) (R)	2 Byte
g)	LED pulse data 2 (UP) (G)	2 Byte
h)	LED pulse data 2 (DOWN) (G)	2 Byte
i)	LED pulse data 2 (UP) (B)	2 Byte
j)	LED pulse data 2 (DOWN) (B)	2 Byte
k)	LED pulse data 2 (UP) (R)	2 Byte
l)	LED pulse data 2 (DOWN) (R)	2 Byte
m)	RLCV (AFE Parameter)	1 Byte
n)	OFFSET (AFE Parameter)	1 Byte
o)	GAIN (AFE Parameter)	2 Byte
p)	Background color compensated data	1 Byte
q)	GAIN Adjustment Black Level MAX Data (First or second side)	2 Byte
r)	HP detection black compensation data	2 Byte x 12
s)	Black level data	by previous scanning pixel count
t)	White level data (G)	by previous scanning pixel count
u)	White level data (B)	by previous scanning pixel count
v)	White level data (R)	by previous scanning pixel count

■ Common to first and second side

LED CURRENT :04	
LED PLS1UP G:0047	
LED PLS1DN G:02d9	
LED PLS1UP B:0047	
LED PLS1DN	
LED PLS1UP	4e466020 : bc bb bd bf b8 ba bc be ba bc bc bf bd bc ba bf
LED PLS1DN	4e466040 : bc b5 b6 bc bc b7 b4 ba be b8 b8 b8 be bb bd bb
LED PLS2UP	4e466060 : bf bd bf ba c0 be ba b7 bb bc b3 b6 bb be b9 bb
LED PLS2DN	4e466080 : bb c1 be ba b9 bc bb b9 b8 bf bd b8 b8 bc be b9
LED PLS2UP	4e4660a0 : f4 ff f4 ff f4 ff f4 ff f4 ff f4 ff f4 ff f4 ff f4
LED PLS2DN	4e4660c0 : f4 ff f4 ff f4 ff f4 ff f4 ff f4 ff f4 ff f4 ff f4
AFE RLCV	4e45c020 : 65 65 68 6a 65 64 68 69 66 65 67 6a 68 65 65 69
AFE OFFSET	4e45c040 : 67 63 63 68 68 64 61 66 69 65 62 65 68 67 66 66
AFE GAIN	4e45c060 : 59 68 66 66 66 6a 69 64 64 67 67 62 63 67 69 66
BACK DATA	4e45c080 : 66 6a 68 63 65 68 68 64 64 6a 69 65 63 67 69 66
MAX BLKCS F	4e45c0a0 : 65 66 68 66 61 63 67 67 63 62 67 67 64 63 66 68
1 : 8451	4e45c0c0 : 65 64 63 66 67 66 62 61 66 64 60 67 63 63 60 5e
2 : 8451	4e45c0e0 : 63 64 62 5f 60 65 63 60 60 63 63 60 60 63 64 61
3 : 8451	4e45c100 : 5e 61 63 61 5f 60 64 62 5e 60 64 62 5e 60 64 62
4 : 8451	4e45c120 : 60 5d 62 64 61 5d 60 61 5d 60 61 5d 60 61 5d 60
5 : 8451	4e45c140 : 63 61 5d 63 65 65 61 5d 63 65 65 61 5d 63 65 65
6 : 8451	4e45c160 : 63 65 62 62 62 61 af b8 b8 b4 b3 bb be b7 b3
7 : 8451	4e45c180 : 63 65 62 62 62 61 af b8 b8 b4 b3 bb be b7 b3
8 : 8451	4e45c1a0 : 61 65 62 62 62 61 ac b1 b8 b6 af b0 b5 b5 ae ad b4 b7
9 : 8451	4e45c1c0 : 61 65 62 62 62 61 ac b1 b8 b6 af b0 b5 b5 ae ad b4 b7
10 : 8451	4e45c1e0 : 61 65 62 62 62 61 ac b1 b8 b6 af b0 b5 b5 ae ad b4 b7
11 : 8451	4e45c180 : 61 65 62 62 62 61 ac b1 b8 b6 af b0 b5 b5 ae ad b4 b7
12 : 8451	4e45c1a0 : 61 65 62 62 62 61 ac b1 b8 b6 af b0 b5 b5 ae ad b4 b7
4e4662a0	4e4659e0 : bb b3 aa b2 b6 b4 aa af b7 b6 af b2 bb bc b7 b5
4e4662c0	4e465a00 : b9 bd b6 b0 b1 b7 b3 ac b3 b5 b7 ae ac b4 b5 b1
4e4662e0	4e465a20 : b9 bd b6 b0 b1 b7 b3 ac b3 b5 b7 ae ac b4 b5 b1
4e466300	4e465a40 : 5a 5f 62 60 5b 5d 60 5f 5a 5c 60 61 5b 59 60 61
4e466320	4e465a60 : 5d 5b 5e 61 5f 5a 5c 5c 60 61 5c 5b 5b 5c 51 5b 58 60
4e466340	4e465a80 : 61 5d 59 5e 61 5f 5a 5c 5d 62 60 5b 5c 51 5b 58 60
4e466360	4e465aa0 : 60 61 5d 58 5d 61 5f 59 5c 60 5f 5a 5b 60 60 5c
4e466380	4e465ac0 : 5b 5f 61 5d 5a 5d 61 5f 5a 5b 5f 5e 59 5a 5f 60
4e4663a0	4e465ae0 : 5b 59 5d 5f 5c 57 5d 5f 5e 59 5b 5f 5b 59 5f
4e4663c0	4e465b00 : 61 5d 5a 5f 61 5e 5a 5e 61 60 5a 5d 61 61 5c 5b
4e4663e0	4e465b20 : 60 60 5c 5b 5f 62 5f 5b 60 60 60 5a 5d 60 60 5b
4e466400	4e465b40 : 5c 62 62 5d 5a 60 62 5f 5a 61 62 5d 5a 60 63 62
4e466420	4e465b60 : 5d 60 64 62 5e 5f 63 64 5f 5f 63 64 5f 5a 61 63
4e466440	4e465b80 : 61 5c 5f 64 64 5d 5e 63 63 5f 5c 62 64 60 5c 62
4e466460	4e465ba0 : 65 62 5c 5e 63 63 5e 63 64 60 5f 65 67 63 5f
4e466480	4e465bc0 : 62 65 62 5c 60 64 63 5e 60 64 65 60 5e 64 63 60
4e4664a0	4e465be0 : 5c 60 63 61 5b 5f 64 63 5d 5e 62 63 5e 5c 62 63
4e4664c0	4e465b00 : 60 5e 61 65 64 5f 61 65 63 5f 5e 63 63 5f 5e 63
4e4664e0	4e465c20 : 65 61 5a 60 63 61 5a 5f 64 63 5d 5f 65 66 62 5f
4e466500	4e465c40 : 63 66 62 5c 5f 63 61 5b 60 62 63 5d 5c 62 63 5f
4e466520	4e465c60 : 5e 62 64 60 5c 61 64 61 5d 5e 64 62 62 5f 64 64
4e466540	4e465c80 : 5f 5d 62 65 61 5d 61 63 62 5c 63 62 5c 63 64 5e 65
4e466560	4e465ca0 : 64 5f 5e 63 66 62 5a 63 64 65 6e 6e 65 64 61 60
4e466580	4e465cb0 : 60 65 61 5e 63 65 64 5d 61 64 60 60 61 61 66 66 60
4e4665a0	4e465cc0 : 60 66 66 63 60 64 65 63 5f 64 60 60 61 62 66 65
4e4665c0	4e465d00 : 61 60 66 67 63 60 67 69 66 64 65 69 67 62 64 67
4e4665e0	4e465d20 : 68 62 5d 68 67 60 62 67 67 62 60 60 5e 68 63 60 64
4e466600	4e465d40 : 67 66 60 62 67 66 62 62 66 66 63 62 67 69 64 61
4e466620	4e465d60 : 65 68 66 61 62 67 67 62 62 67 67 62 67 69 64 65
4e466640	4e465d80 : 60 64 69 66 61 63 68 68 64 62 67 68 64 61 66 68
4e466660	4e465da0 : 66 61 64 69 66 61 63 67 66 62 61 67 68 65 64 66
4e466680	4e465dc0 : 69 66 63 64 67 66 60 61 66 63 5f 5e 64 67 62 5e
4e4666a0	4e465de0 : 62 66 64 60 62 65 64 61 61 66 67 62 62 66 67 63
4e4666c0	4e465e00 : 60 63 65 62 5e 60 65 63 5e 5f 64 65 60 5f 65 67
4e4666e0	4e465e20 : 63 60 64 67 64 61 62 57 65 61 61 65 65 60 5f 64
4e466700	4e465e40 : 66 63 60 63 67 65 61 64 66 67 63 62 66 66 63 63
4e466720	4e465e60 : 66 68 64 60 65 68 64 61 64 68 67 63 63 68 69 65
4e466740	4e465e80 : 63 67 69 65 63 69 6b 6a 67 68 6b 6a 64 64 6a 6a
4e466760	4e465ea0 : 65 63 68 6b 67 62 68 6b 69 68 68 6d 6c 68 67 6b
4e466780	4e465ec0 : 6c 66 67 69 6a 67 64 68 6b 68 68 6d 6c 68 67 6b
4e4667a0	4e465ee0 : 6a 64 63 68 6a 65 62 65 68 65 61 66 6a 68 64
4e4667c0	4e465f00 : 66 6a 69 66 66 69 6a 66 65 69 6a 66 64 67 6a 66
4e4667e0	4e465f20 : 63 66 6a 69 65 64 69 69 63 63 67 69 66 63 66 6a
4e466800	4e465f40 : 68 65 65 69 68 66 66 6a 69 65 64 66 69 65 64 67
4e466820	4e465f60 : 69 67 62 65 69 68 64 63 67 67 63 62 67 69 65 62
4e466840	4e465f80 : 64 68 67 65 65 68 66 64 64 69 68 63 62 66 67 62
4e466860	4e465fa0 : 5e 63 66 63 5f 61 65 66 62 62 66 66 62 61 65 66
4e466880	4e465fc0 : 63 61 63 65 64 60 61 66 66 61 61 65 65 63 62 65
4e4668a0	4e465fe0 : 66 64 62 63 65 64 63 63 67 66 63 62 65 66 62 63
4e4668c0	4e465fd0 : 66 67 63 62 65 67 66 61 62 65 64 60 61 64 66 61
4e4668e0	4e465ff0 : 60 65 66 63 63 65 67 65 61 63 66 66 65 64 64 67 67
4e466900	4e466000 : 62 61 55 66 63 61 64 67 65 63 65 68 67 63 63 68
4e466920	4e466020 : 68 63 61 65 67 63 62 66 68 67 64 65 69 6a 66 64
4e466940	4e466040 : 67 68 63 61 66 68 64 61 65 67 66 62 63 68 67 63
4e466960	4e466060 : 64 68 69 67 68 69 6b 67 67 68 6a 69 66 65 68 68
4e466980	4e466080 : 63 64 68 67 65 61 61 67 62 62 60 68 66 64 65 69
4e4669a0	4e4660a0 : 67 65 66 6a 69 68 67 6b 6a 68 68 68 6a 67 65 69
4e4669c0	4e4660c0 : 69 67 64 66 6a 68 66 65 6a 6b 65 65 6a 67 65
4e4669e0	4e4660e0 : 67 6a 67 65 67 6b 6b 67 67 6b 6b 67 67 69 68 68
4e466a00	4e466100 : 68 6b 6c 6a 69 68 6b 6a 67 66 69 69 66 66 6a 6b
4e466a20	4e466120 : 67 65 68 6b 69 66 67 6b 6a 66 67 6a 6b 66 67 69
4e466a40	4e466140 : 6b 67 65 68 6a 68 65 67 6a 6a 66 66 6a 69 66 66
4e466a60	4e466160 : 69 6c 67 65 68 6a 68 66 66 69 67 62 64 69 68 65
4e466a80	4e466180 : 64 69 6a 67 67 69 6b 68 67 67 6b 69 63 64 68 69
4e466aa0	4e4661a0 : 64 63 68 69 67 62 65 69 67 67 67 6a 69 65 66 6a
4e466ac0	4e4661c0 : 6b 66 66 68 69 65 62 65 69 66 62 65 69 69 64 64
4e466ae0	4e4661e0 : 69 6a 66 63 66 68 65 60 66 69 68 66 66 69 68

Fig. 5-1

1.3.3 ADF performance test (Function code 08)

<Function>

This function is used to test the performance of the automatic document feeder (ADF). The scanned pages of the documents fed by the ADF are counted and the result is displayed on the LCD.

<Operating procedure>

- (1) Load documents on the ADF unit. "DOC.READY" is displayed on the LCD.
- (2) Press the **0** and **8** keys in this order in the initial state of the maintenance mode. The machine displays "ADF CHECK P.**" on the LCD and ejects documents while counting the number of scanned pages. (** indicates the current count of scanned pages.)

Note:

For duplex scanning models, as 2 faces are scanned per a sheet of document, the page count increases by two each time a sheet of document is ejected.

- (3) Press the **X** key to return the machine to the initial state of the maintenance mode.

Note:

- If this test is performed as the ADF cover is opened, the machine displays "NO DOCUMENT" on the LCD and returns to the initial state of the maintenance mode.
- If this test is performed as no documents are loaded in the ADF, the machine displays "NO DOCUMENT" on the LCD and returns to the initial state of the maintenance mode.

1.3.4 Monochrome image quality test pattern (Function code 09)

<Function>

This function is used to print various monochrome test patterns and check the quality and if there is any image loss.

<Operating procedure>

- (1) Press the **0** and **9** keys in this order in the initial state of the maintenance mode. "MAINTENANCE 09" is displayed on the LCD. Printing of a monochrome image quality test pattern (see the figure below) is started.
- (2) When printing is finished, the machine returns to the initial state of the maintenance mode.

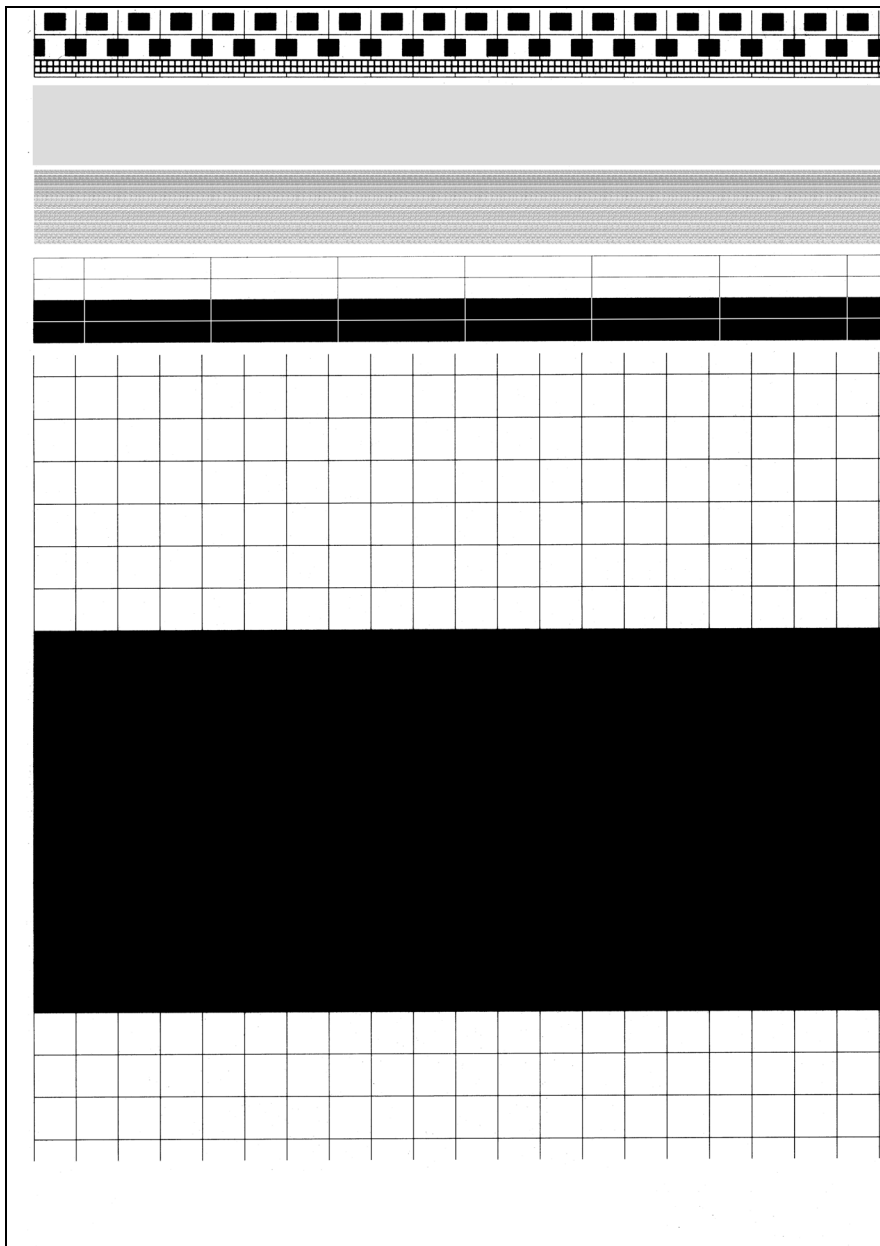

Fig. 5-2

1.3.5 Worker switch (WSW) setting and printout (Function code 10, 11)

[1] Worker switch (WSW) setting (Function code 10)

<Function>

The worker switches shown in the table below can be used to set the function to satisfy various requirements. The switch setting can be changed using the keys on the control panel. The worker switches are factory set to conform with the laws and regulations of the country the machine is shipped to. Do not change these settings unless necessary.

WSW No.	Function	WSW No.	Function
WSW01	Dial pulse setting	WSW29	Function setting 7
WSW02	Tone signal setting	WSW30	Function setting 8
WSW03	PABX mode setting	WSW31	Function setting 9
WSW04	Transfer facility setting	WSW32	Function setting 10
WSW05	1st dial tone and busy tone detection	WSW33	Function setting 11
		WSW34	Function setting 12
WSW06	Redial/Pause key setting and 2nd dial tone detection	WSW35	Function setting 13
		WSW36	Function setting 14
WSW07	Dial tone setting 1	WSW37	Function setting 15
WSW08	Dial tone setting 2	WSW38	V.34 transmission settings
WSW09	Protocol definition 1	WSW39	V.34 transmission speed
WSW10	Protocol definition 2	WSW40	V.34 modem settings
WSW11	Busy tone setting	WSW41	ON-duration of the scanning light source
WSW12	Signal detection condition setting		
WSW13	Modem setting	WSW42	Internet mail settings
WSW14	AUTO ANS facility setting	WSW43	Function setting 16
WSW15	Redial facility setting	WSW44	Speeding up scanning-1
WSW16	Function setting 1	WSW45	Speeding up scanning-2
WSW17	Function setting 2		
WSW18	Function setting 3	WSW46	Monitor of power ON/OFF state and parallel port kept at high
WSW19	Transmission speed setting		
WSW20	Overseas communications mode setting	WSW47	Switching between high-speed USB 2.0 and full-speed USB 1.1
		WSW48	USB setup latency
WSW21	TAD setting 1	WSW49	End-of-copying beep and print in black
		WSW50	SDAA settings
WSW22	ECM and call waiting caller ID	WSW51	Function setting 17
WSW23	Communications setting	WSW52	Function setting 18
WSW24	TAD setting 2	WSW53	Function setting 19
WSW25	TAD setting 3	WSW54	Function setting 20
WSW26	Function setting 4	WSW55	Interval of time required for the developing bias voltage correction
WSW27	Function setting 5		
WSW28	Function setting 6	WSW56	Function setting 21

WSW No.	Function	WSW No.	Function
WSW57	Function setting 22	WSW73	Reserved (Change of the setting is prohibited)
WSW58	Function setting 23		
WSW59	Function setting 24	WSW74	ADF stop control
WSW60	Function setting 25	WSW75	Paper ejecting distance of the switch back
WSW61	Scanning light intensity to judge to be stable 1		
WSW62	Scanning light intensity to judge to be stable 2		
WSW63	Function setting 26	WSW76	The limited number of the documents in reverse for paper ejection of the one-sided scanning from ADF
WSW64	Setting the language/Default paper size		
WSW65	Setting the paper support		
WSW66	Reserved (Change of the setting is prohibited)		
WSW67	Reserved (Change of the setting is prohibited)	WSW77	The limited number of the documents in reverse for paper ejection of the two-sided from ADF
WSW68	Reserved (Change of the setting is prohibited)	WSW78	Recording stop function when the drum reaches the end of life
		WSW79	Function setting 27
WSW69	Reserved (Change of the setting is prohibited)	WSW80	Copying speed control function
WSW70	Reserved (Change of the setting is prohibited)	WSW81	Changing emulation function enable/disable setting
		WSW82	AirPrint Icon No. setting
WSW71	Reserved (Change of the setting is prohibited)	WSW83	Reserved (Change of the setting is prohibited)
WSW72	Reserved (Change of the setting is prohibited)	WSW84	Reserved (Change of the setting is prohibited)

[2] Printout of worker switch (WSW) data (Function code 11)

<Function>

This function is used to print out the setting items and the details set by the worker switches.

<Operating procedure>

- (1) Press the 1 key twice in the initial state of the maintenance mode.
- (2) "PRINTING" is displayed on the LCD and the CONFIGURATION LIST (see the figure below) is printed.
- (3) When printing is finished, the machine returns to the initial state of the maintenance mode.

```

                                CONFIGURATION LIST
                                MODEL : 8CE-517
                                TIME  : 01/03/2015 03:40AM
                                REV.   : U1311250117VER.U
                                PGT    : 5.00
                                SLM    : 94A5
                                SER.#  : 000001234567890

WSW01 = 00000010
1-2. DIAL FORMAT                : NORMAL
3-4. BREAK TIME                 : 60 MS
5-6. INTERDIGIT PAUSE          : 800 MS
7. DP/PB CHANGE IN USER SW    : NO
8. DP/PB FIXING SELECTION      : PB
WSW02 = 11111010
1-2. ON TIME                    : 100 MS
3-4. OFF TIME                   : 140 MS
5-8. LINE BEEP ATTENUATOR      : 10 DB
WSW03 = 10111000
1. PARA. CNG DETECTION1        : B
2-4. NOT USED
5. PARA. CNG DETECTION2        : B
6-8. NOT USED
WSW04 = 00010110
1-4. NOT USED
5. DGM DELAY +4SEC             : OFF
6-8. FLASHING TIME             : 500 MS
WSW05 = 00000110
1-3. DIAL TONE DETECTION        : 3.5 SEC WAITING
4. REMOTE ID DETECTION TIMEOUT : 2 SEC
5-6. BUSY TONE DETECTION (CALLING) : AFTER DIALING
7. BUSY TONE DETECTION (CALLED)  : OFF
8. NOT USED
WSW06 = 00101100
1-3. PAUSE KEY                  : 3.5 SEC WAITING
4-6. 2ND DT DETECTION TIME      : 620 MS
7. 2ND DT DETECTION CYCLE      : 1 CYCLE
8. 2ND DT INTERRUPT DETECTION TIME : 30 MS
WSW07 = 01001100
1-2. FREQUENCY RANGE           : INITIAL DATA
3. NOT USED
4-6. 2ND DT DETECTION LEVEL     : -30 DBM
7. 1ST DT INTERRUPT DETECTION TIME : 30 MS
8. NOT USED
WSW08 = 01100111
1-3. 1ST DT DETECTION TIME      : 620 MS
4-6. 1ST/2ND DT TIME OUT       : 10 SEC
6-8. 1ST DT DETECTION LEVEL     : -42 DBM
WSW09 = 00000000
1. EON FRAME                    : 256 OCTET
2. NON STANDARD FACILITIES      : ON
3-4. TIMES OF FALL BACK        : 4
5. T5 TIMER                     : 300 SEC
6. T1 TIMER                     : 35 SEC
7-8. CALLING TIMEOUT           : 60 SEC
WSW10 = 00010100
1. NOT USED
2. TIMING OF LAST DIGIT-MODEM CHANGE : 100 MS
3. TIMING OF OML ON CNG TRANSMISSION : 2 SEC
4. TIMING OF OML ON CED TRANSMISSION : 2 SEC
5-6. TRAINING RETRIES          : 2
7. CODING METHOD MR             : ON
8. CODING METHOD MMR            : ON
WSW11 = 01010000
1-2. FREQUENCY RANGE           : INITIAL DATA
3-8. ON/OFF TIME                : 175 - 600 / 175 - 600 MS
WSW12 = 10011001
1-2. OFF DETECTION TIME        : 700 MS
3-4. AUTO ANS OFF DETECTION TIME : 7 SEC
5-6. ON DETECTION TIME         : 250 MS
7-8. NOT USED
```

Fig. 5-3

1.3.6 Operational check of LCD (Function code 12)

<Function>

This function is used to check that the LCD on the control panel is operating normally.

<Operating procedure>

- (1) Press the **1** and **2** keys in this order in the initial state of the maintenance mode.
A completely blank screen is displayed on the LCD.
- (2) Each time you press the **#** key, the LCD cycles through the displays as shown below.
When you press the ***** key, the display on the LCD returns to the preceding one. When you press the **#** key with Display 7 shown on the LCD, Display 1 appears.
- (3) When the **X** key is pressed, the machine returns to the initial state of the maintenance mode, regardless of the display status.

■ Display on LCD

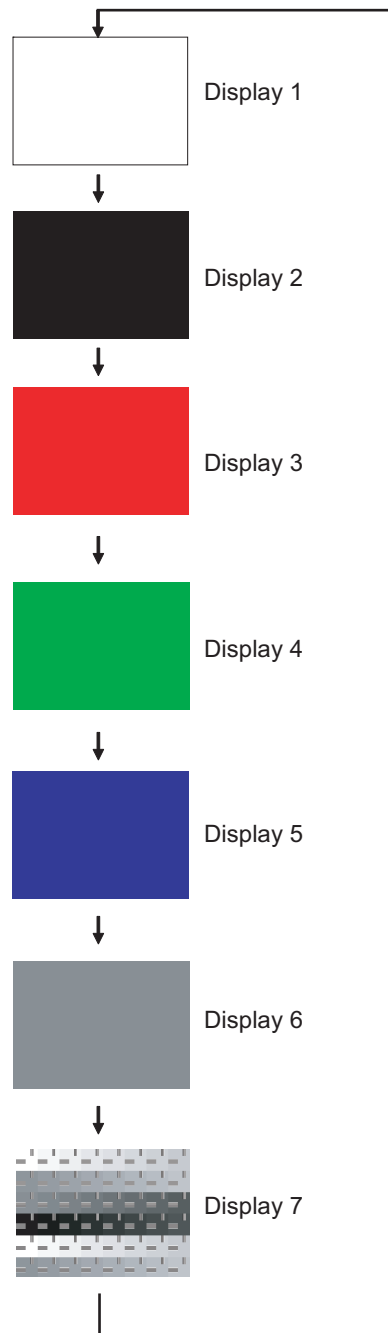

Fig. 5-4

1.3.7 Operational check of control panel key (Function code 13)

<Function>

This function is used to check that the keys on the control panel operate normally.

<Operating procedure>

- (1) Press the **1** and **3** keys in this order in the initial state of the maintenance mode. "00" is displayed on the LCD.
- (2) Press the keys in the order designated in the figure shown below.
The LCD shows the corresponding number in decimal notation each time a key is pressed.
Check that the displayed number is correct by referring to the figure below. If the keys are pressed in the incorrect order, the machine displays the "INVALID OPERATE" on the LCD. Press the **X** key, and then press the correct keys.
- (3) After the last number key is pressed, the machine returns to the initial state of the maintenance mode. To cancel this operation and return the machine to the initial state of the maintenance mode during the above procedure, press the **X** key.

■ Order to press keys

- Common to all the models



Fig. 5-5

1.3.8 Software version check (Function code 25)

<Function>

This function is used to check the version information of the firmware or programs, or check sum information.

<Operating procedure>

- (1) Press the **2** and **5** keys in this order in the initial state of the maintenance mode.
"TOTAL:Ver*" is displayed on the LCD.
- (2) When you press the **Mono Start** key, the display on the LCD changes to the next item.
- (3) Press the **X** key and finish this operation to return the machine to the initial state of the maintenance mode.

LCD	Description
TOTAL: Ver T * ¹	Main firmware version information (A): Revision information
SUB1 : Ver1.00 (P) * ¹	Sub firmware version information (P): Identifier of PCL/PS * ²
ENG : Ver1.00	Engine firmware version information
NET : Ver1.00	Network program version information
HV : Ver1.00 BXXX	High voltage CPU program version and PCB information
PNL:T1308201900	Panel firmware version information
PNLB:01308051500	Panel boot firmware version information
i0801170900:0000	I-FAX version information
B0608071049:5708 * ¹	Boot program creation date
U0612271600:7B0A * ¹	Main firmware creation date
D0611301115:E6C3 * ¹	Demo firmware data creation date
F0612312359:1234 * ¹	Font firmware creation date
P0612271602:BD40 * ¹	Sub firmware (PCL/PS) creation date
ROM Check Sum	Check sum self-diagnosis function * ³

*¹ How to display the check sum information

Press the **SET** key when its version information is displayed on the LCD to display the check sum information. Press the **SET** key again to return to the version information display.

*² (P) indicates that the firmware supports PCL/PS.

*³ There are two types of check sum information which can be checked with this function. This function checks if these two types of check sum information are matched each other.

When you press the **SET** key while "ROM Check Sum" is displayed, check is automatically conducted for each ROM of each software part. When the check sum is matched, "OK" is displayed on the LCD. When all ROMs result in OK, "ROM Check Sum OK" is displayed at the end, and the operation is finished. When the check sum of any ROM is not matched, "NG" is displayed, and the display stops.

1.3.9 “One Push Demo” setting (Function code 28)

<Function>

The One Push Demo function is to implement demo printing by key operation, which is mainly used for sales promotion at the shop.

This function is disabled once printing is performed from the computer. Change the setting to enable the function.

OnePushDemo = ON (Enabled)/OFF (Disabled)

The setting currently selected is marked “*”.

<Operating procedure>

- (1) Press the **2** and **8** keys in this order in the initial state of the maintenance mode.
“OnePushDemo=ON” is displayed on the LCD.
- (2) To enable the function, display “OnePushDemo=ON” using the ▲ or ▼ key. To disable the function, display “OnePushDemo=OFF”.
- (3) Press the **SET** key. The displayed setting is confirmed and the machine returns to the initial state of the maintenance mode.

Note:

- To terminate this operation, press the **X** key. The machine returns to the initial state of the maintenance mode.
- Once the One Push Demo function is enabled, printing from a computer does not disable this function unless the power is turned OFF. After the One Push Demo function is enabled, if the power is turned OFF and ON again, and then printing is made from a computer, the function is disabled.

1.3.10 Operational check of sensors (Function code 32)

<Function>

This function is used to check that the sensors are operating normally.

<Operating procedure>

- (1) Press the **3** and **2** keys in this order in the initial state of the maintenance mode.
 "C1C2MPCVRCPO****" is displayed on the LCD.
 When the T2 paper tray unit is not installed, "C1**MPCVRCPO****" is displayed, and the machine beeps 400Hz OFF, 400Hz small, 400Hz middle, 400Hz large, 1,100Hz OFF, 1,100Hz small, 1,100Hz middle, and 1,100Hz large tones cyclically to test the speaker.

Note:

To stop beeping, press the **SET** key.

- (2) Pressing the **Mono Start** key displays the next group.

The table below summarizes the displays on the LCD, sensor names and detection status.

LCD	Sensor names	Detection status (displayed/not displayed)
C1	T1 paper feed sensor	Paper tray 1 installed/not installed
C2	T2 paper feed sensor	T2 paper tray unit installed/not installed
MP	MP paper empty sensor	MP tray paper not detected/detected
CV	Front cover sensor	Front cover closed/open
RC	Back cover sensor	Back cover closed/open
PO	Eject sensor	Paper not detected/detected
L2	T2 plate origin sensor	Plate down of T2 paper tray unit/ Plate up of T2 paper tray unit
T2	T2 connect sensor	T2 paper tray unit connected/not connected
MR	MP registration front sensor	Paper not detected/detected
RM	Registration front sensor	Paper not detected/detected
RA	Registration rear sensor	Paper not detected/detected
FW	Waste toner sensor	Waste toner detected/not detected
NK	New toner sensor (Black)	OFF/ON
NC	New toner sensor (Cyan)	OFF/ON
NM	New toner sensor (Magenta)	OFF/ON
NY	New toner sensor (Yellow)	OFF/ON
KC	Toner sensor (Black)	Toner detected/not detected
CC	Toner sensor (Cyan)	Toner detected/not detected
MC	Toner sensor (Magenta)	Toner detected/not detected
YC	Toner sensor (Yellow)	Toner detected/not detected

LCD	Sensor names	Detection status (displayed/not displayed)
MAC XXC	Internal temperature sensor	XX °C/NG
BT XXC	Belt temperature sensor	0 °C (The value will not be changed since this sensor is not installed.)
TMP XXC	External temperature sensor	XX °C/NG
HUM XXC	External humidity sensor	XX %/NG
DF	Document detection sensor	Without documents/With document
DR	First side document scanning position sensor	Without documents/With document
AC	ADF cover sensor	ADF cover closed/open
DB	Second side document scanning position sensor	Without documents/With document

Note:

If the external temperature/humidity sensor detects the unusual value, the machine displays "NG" on the LCD.

- (3) Check that the display on the LCD is changed when the detection condition of each sensor is changed.
For example, insert paper through the registration front/rear sensor, open the front cover or the back cover, remove the toner cartridge, make a jam at the paper outlet, insert paper from the MP tray, set the paper tray, etc.
- (4) Press the **X** key and finish this operation to return the machine to the initial state of the maintenance mode.

■ **Location of sensors**

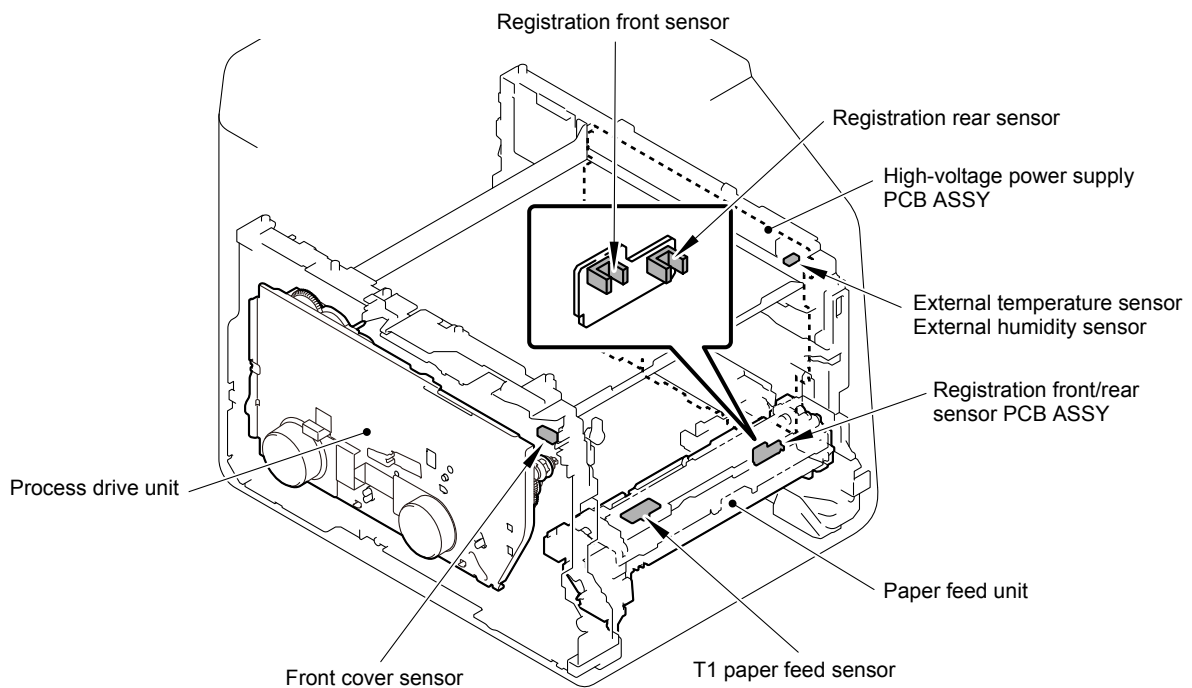

Fig. 5-6

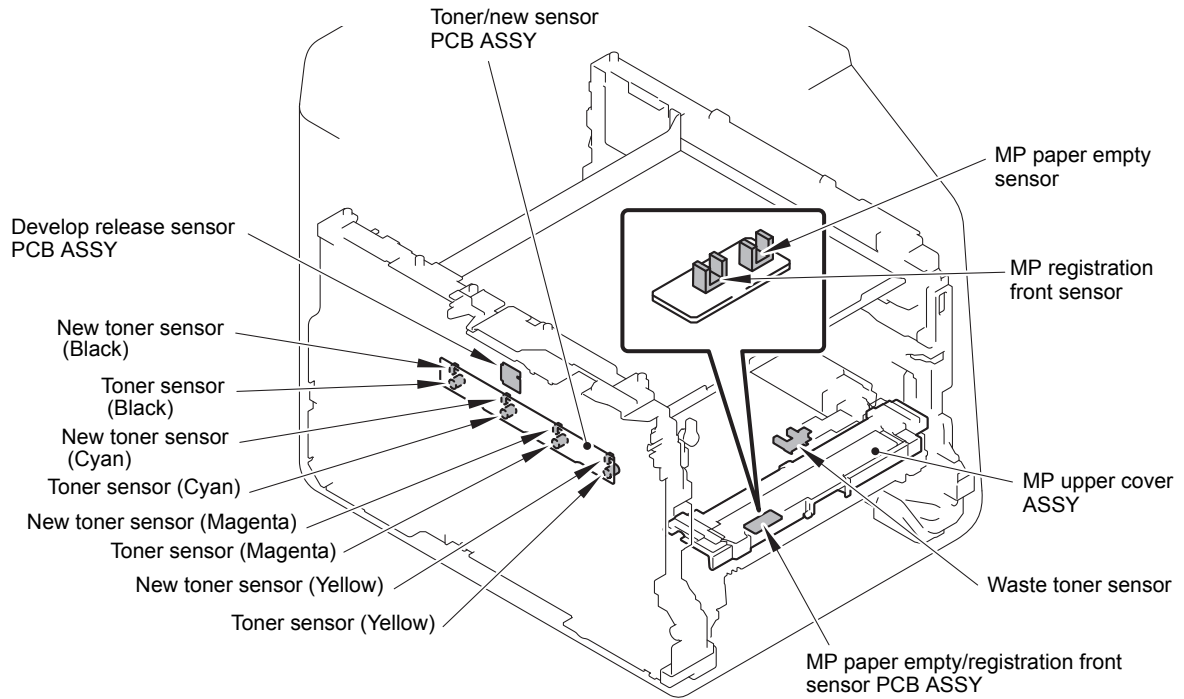

Fig. 5-7

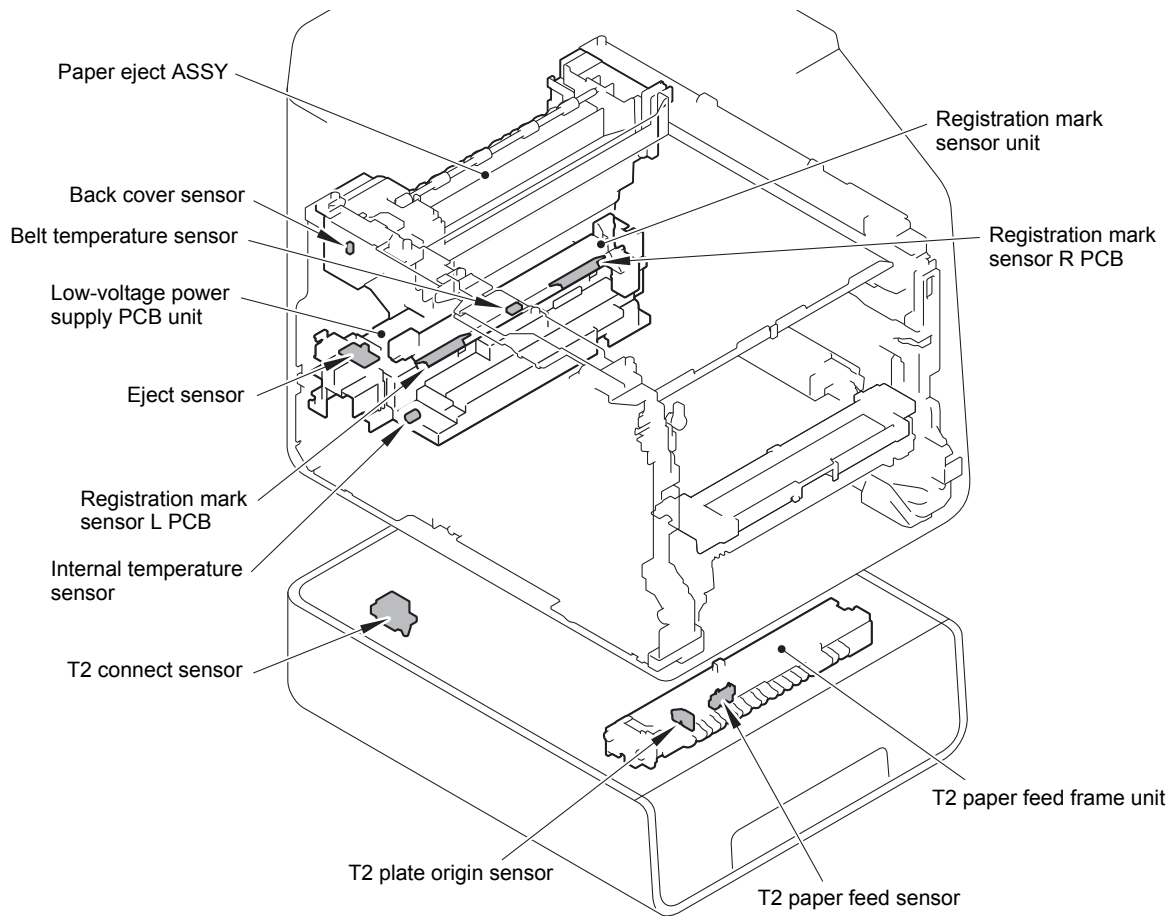

Fig. 5-8

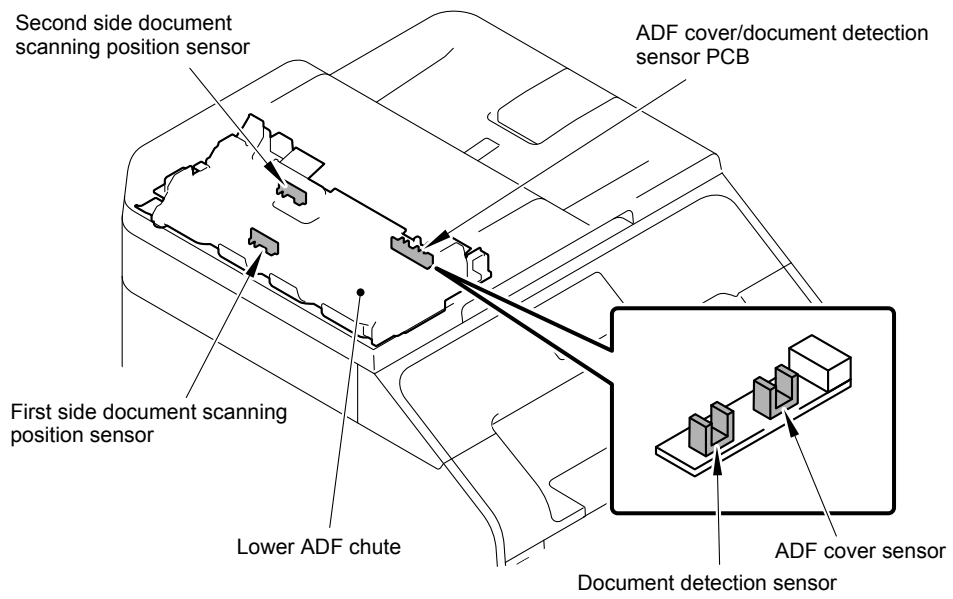

Fig. 5-9

1.3.11 LAN connection status display (Function code 33)

<Function>

This function is used to check the connection status of the wired LAN.

<Operating procedure>

- (1) Press the **3** key twice in the initial state of the maintenance mode.
- (2) Based on the wired LAN connection status of the machine, the corresponding items shown in the table below is displayed on the LCD.
- (3) Press the **X** key to return the machine to the initial state of the maintenance mode.

LCD	LAN connection status
Active 100B-FD	100B-FD
Active 100B-HD	100B-HD
Active 10B-FD	10B-FD
Active 10B-HD	10B-HD
Inactive	Not connected.

1.3.12 EEPROM Dump Print (Function code 40)

<Function>

This function is to print the EEPROM information.

<Operating procedure>

- (1) Press the **4** and **0** keys in this order in the initial state of the maintenance mode.
“E2PDUMP ENGN ALL” is displayed on the LCD.
- (2) Press the **▲** or **▼** key to select the information you wish to print. Press the **SET** key, and then the “E2DUMP PRINT” is displayed on the LCD.
- (3) Press the **SET** key, and then the “E2DUMP PRINTING” is displayed on the LCD.
The printer starts to print the EEPROM log.
- (4) Upon completion of EEPROM logs printing, the machine returns to the initial state of the maintenance mode.

Note:

- Press the **X** key and finish this operation to return the machine to the initial state of the maintenance mode.
- If an error occurs during printing, it is necessary to start from the beginning.
- The serial number of the machine is printed on the first line on each page.

The terms of EEPROM logs on the LCD are as follows;

LCD	Description
E2PDUMP ENGN ALL	Print of all the values stored in the E2PROM of the engine control unit. (print of 1 page)
E2PDUMP MAIN TOP	Print of the values stored in the E2PROM corresponding to the top 1 Kbytes of the main controller. (print of 1 page)
E2PDUMP MAIN BTM	Print of the values stored in the E2PROM corresponding to the last 1 Kbytes of the main controller. (print of 1 page)
E2PDUMP MAIN REG	Print of the values stored in the E2PROM of the information related to the compensation values of the main controller. (print of 1 page)
E2PDUMP MAIN ALL	Print of all the values stored in the E2PROM of the main controller. (print of 8 pages)

1.3.13 Backup of machine information (Function code 41)

<Function>

This function is used to back up the machine information and user setting information into an USB flash memory and restores it when necessary.

- User setting information (Password, user settings, Network settings, etc.)
- Machine information (Preset values, count values, error information, etc.)

However, the following information is not backed up: machine serial number and device and PCB-specific information such as MAC address.

Note:

- The backup and restore procedures can also be used with the maintenance mode operation by end users. However, end users are allowed to restore the user setting information (Import PI) only and not allowed to restore all the information, such as machine information and user setting information (Import ALL).
- An USB flash memory for backup should have a free space larger than the RAM size of the machine.
- When performing this procedure for any other machine with the same USB flash memory, delete the data previously stored in the USB flash memory.
- If new information is backed up to the USB flash memory where the backup data of the same model is saved, the backup data is overwritten with the new information.

<Operating procedure>

Backup Procedure

- (1) On the computer, create a "BROTHER" folder in an USB flash memory to be used for saving backup data.
- (2) Insert the USB flash memory into the slot of the machine in the initial state of the maintenance mode. The "USB Host Connect" is displayed on the LCD.
- (3) Press the **4** and **1** keys in this order. The "Export to USB" is displayed on the LCD.
- (4) Press the **Mono Start** key. "*****.ser" is displayed on the LCD. ("*****" shows the name of the model.)
- (5) Press the **Mono Start** key. The "Export OK?" is displayed on the LCD.
- (6) Press the **Mono Start** key. "Please wait" is displayed on the LCD, and the backup data is saved in an USB flash memory. After the backup data is saved, "USB Host Connect" is displayed on the LCD, and the machine returns to the initial state of the maintenance mode.
- (7) Remove the USB flash memory from the machine.

Note:

- Never remove the USB flash memory from the machine when exporting is in progress.
- If this procedure has been started with the maintenance mode operation by the end user, the machine returns to the ready state after showing the "Please wait" on the LCD.

If an error occurs while executing Function code 41, error items below are displayed on the LCD. Press the **X** key, and the machine returns to the initial state of the maintenance mode. Then, take a measure.

LCD	Cause
USB Mem used	The USB flash memory is being used by another operation.
Insert USB Mem	No USB flash memory is inserted.
No file	The file name is invalid or no "BROTHER" folder exists.
USB Mem Error	USB flash memory error
Write Error	The USB flash memory does not have enough space.

Restoration Procedure

- (1) Insert the USB flash memory containing the backup data into the slot of the machine in the initial state of the maintenance mode. The "USB Host Connect" is displayed on the LCD.
- (2) Press the **4** and **1** keys in this order. The "Export to USB" is displayed on the LCD.
- (3) Press the **▲** or **▼** key to display the desired restore method shown below on the LCD, and press the **Mono Start** key. "*****.seri" is displayed on the LCD. ("*****" shows the name of the model.)
- (4) Press the **Mono Start** key. The "Reboot OK?" is displayed on the LCD.
- (5) Press the **Mono Start** key. "Please wait" is displayed on the LCD and the restoring is performed. Upon completion of restoring, the machine returns to the initial state of the maintenance mode.
- (6) Remove the USB flash memory from the machine.

Restore methods

"Import PI" for restoring only user setting information

"Import ALL" for restoring all backup data including machine information

Note:

- Never remove the USB flash memory from the machine when exporting is in progress.
- If the serial number of the backup data saved in the USB flash memory and the serial number of the machine do not match, the data cannot be restored.

If an error occurs while executing Function code 41, error items below are displayed on the LCD. Press the **X** key, and the machine returns to the initial state of the maintenance mode. Then, take a measure.

LCD	Cause
USB Mem used	The USB flash memory is being used by another operation.
Insert USB Mem	No USB flash memory is inserted.
No file	The file name is invalid or no "BROTHER" folder exists. There is no backup data.
USB Mem Error	USB flash memory error
Machine ID Error	Serial number does not match. The data is for other machine.
Write Error	A write error occurred.

1.3.14 PC print function setting (Function code 43)

<Function>

This function is used to change the settings of the various print functions summarized in the table below.

<Operating procedure>

- (1) Press the **4** and **3** keys in this order in the initial state of the maintenance mode.
"Manual Feed" is displayed on the LCD.
- (2) Press the **▲** or **▼** key to select the function you want to set and press the **SET** key.
- (3) For fixed parameters (On/Off, etc.), press the **▲** or **▼** key, or change the parameter using the numeric keys. And press the **SET** key.
For parameters requiring numerical value entry, directly input a numeric value from the ten-key pad and press the **SET** key.
- (4) Press the **X** key to return the machine to the initial state of the maintenance mode.

■ Function setting

LCD	Detail description	Set value	Initial value
Manual Feed	Switching of the Manual Feed	On/Off	Off
Resolution	Resolution to print	300/600/1,200 dpi	600 dpi
Toner Save	Switching of the Toner Save	On/Off	Off
Density	Switching of the Density level	-6 to 6	0
Job Cancel Time out	Setting of the time until the host time-out at the Job Cancel	0 to 225 (seconds)	4 (seconds)
Sleep Time	Setting of the time until enter the Sleep Mode	0 to 99 (minutes)	5 (minutes)
Page Protection	Switching of the protection of the page memory	Off/Letter/A4/Legal/Auto	Off
Emulation	Switching of the emulation	Auto/HP/PS	Auto
Auto I/F Time	Switching of the I/F open time	1 to 99 (seconds)	5 (seconds)
Media Type	Switching of the paper type	Thin/Plain/Thick/Thicker/Tranparency/Recycled/Bond/Envelopes/EnvThin/EnvThick	Plain or Thin
Paper Size	Switching of the area of develop the image	Letter/Legal/A4/Executive/ISOB5/JISB5/A5/ISOB6/A6/Monarch/C5/COM10/DL/DLL/A4Long/Hagaki/Folio	Letter or A4
Copies	Switching of the print copies	1 to 99 (pages)	1 (page)
Orientation	Switching of the print direction	PortLait/Landscape	Portlait
P-Pos X-Offset	Switching of the offset print position of the landscape orientatio	-500 to 500 (1/300 dpi)	0 (1/300 dpi)
P-Pos Y-Offset	Switching of the offset print position of the portrait orientation	-500 to 500 (1/300 dpi)	0 (1/300 dpi)

LCD	Detail description	Set value	Initial value
Auto FF	Switching of the auto form feed	On/Off	Off
Auto FF Time	Switching of the time-out period of the auto form feed	1 to 99 (seconds)	5 (seconds)
FF Surpress	Switching of the FF Suppress	On/Off	Off
Auto LF	Switching of the auto LF	On/Off	Off
Auto CR	Switching of the auto CR	On/Off	Off
Auto WRAP	Switching of the auto CRLF at the print width	On/Off	Off
Auto Skip	Switching of the Skip at the backend/tip of the paper	On/Off	On
Left Margin	Switching of the margin at the left end	0 to 145 (columus)	0 (columu)
Right Margin	Switching of the margin at the right end	10 to 155 (columus)	80 (columus)
Top Margin	Switching of the margin at the upper end	0 to 2.00 (inches)	0.5 (inches)
Bottom Margin	Switching of the margin at the bottom end	0 to 2.00 (inches)	0.5 (inches)
Lines	Number of the text lines in the page	5 to 128 (lines)	60 (lines)
Error Print	Switching of the ErrorPrint of the PostScript	On/Off	On

■ Detail description

LCD	Detail description
Manual Feed	Effective for the print from the computer, or for the print of the NetWorkConfig/TestPrint/FontList/Configuration from the panel. When select the tray on the computer, the setting becomes effective. And this setting is ignored.
Resolution	Effective only for the print from the computer. When set the Resolution on the computer, the setting becomes effective. And this setting is ignored.
Toner Save	Effective for all print, and change the setting of the Function Menu. However, as for the Copy, this setting becomes invalid. When set the Toner Save on the computer, the setting becomes effective. And this setting is ignored.
Density	Effective for the print from the computer, or for the print of the NetWorkConfig/TestPrint/FontList/Configuration from the panel. Link the setting of the Toner Save. Judge the both setting, and decide the density. When set the Density on the computer, the setting becomes effective. And this setting is ignored.
Job Cancel Time out	Configure the setting for the time until the host time-out at the Job Cancel. The setting value is the second time scale.
Sleep Time	Configure the setting for the time until shift to the Sleep Time. Change the setting of the Function Menu.

LCD	Detail description
Page Protection	Allocate the page memory used for the internal processing of data in the computer before output. Set in the PCL-Core. There is not the influence of the memory management problem of the machine.
Emulation	Configure the setting for the Emulation. Change the setting of the Function Menu. When the data includes the ENTER LANGUAGE, the setting becomes effective. And this setting is ignored.
Auto I/F Time	Configure the setting for the interface open time. The function is in the PC-Print. When the PC-Scan/Remote-SetUp works on the way, the setting becomes invalid.
Media Type	Effective for the print from the computer. When set the type of the paper on the computer, the setting becomes effective. And this setting is ignored. The default value is different by the country setting. "Thin" is the default for China and "Plain" is the default for other countries.
Paper Size	Change the image development area. Does not set the Paper Size of the Menu, set the drawing size of the PC-Print. When set the size of the paper on the computer, the setting becomes effective. And this setting is ignored. "Letter" is the default for the U.S.A. and Canada and "A4" is the default for other countries.
Copies	Effective for the print from the computer. When set the number of the copies on the computer, the setting becomes effective. And this setting is ignored.
Orientation	Configure the switching for the print direction. Effective for the print from the computer.
P-Pos X-Offset	Configure the setting for the offset print position of the landscape orientation. Effective for the print from the computer. When set the X-Offset on the computer, the setting becomes effective. And this setting is ignored.
P-Pos Y-Offset	Configure the setting for the offset print position of the portrait orientation. Effective for the print from the computer. When set the Y-Offset on the computer, the setting becomes effective. And this setting is ignored.
Auto FF	Configure the setting for the ON/OFF of the Auto Form Feed. Effective for the print from the computer.
Auto FF Time	Configure the setting for the TimeOut, when the Auto Form Feed is ON.
FF Surpress	Configure the setting for the skip of the blank page. Effective for the print from the computer. The blank data in the Copy/Fax cannot be turned ON/OFF in this setting.
Auto LF	Configure the setting for the auto line feed.
Auto CR	Configure the setting for the auto Carriage Return.
Auto WRAP	Configure the setting for the auto CRLF at the print width.
Auto Skip	Configure the setting for the skip at the back-end/tip of the paper and add the blank space.
Left Margin	Configure the setting for the column space at the left end.
Right Margin	Configure the setting for the column space at the right end.
Top Margin	Configure the setting for the space at the top end.
Bottom Margin	Configure the setting for the space at the bottom end.
Lines	Configure the setting for the number of the lines in the PCL.
Error Print	Configure the setting for the ErrorPrint of the BR-Script3.

**1.3.15 Changing return value of USB No./Switching Dither Pattern/
Switching of ON/OFF of DirectPrint Color mode-Improve Gray Color/
Switching of timing to execute Auto Registration/
Adjusting left-end print start position on second side in duplex printing/
Change of the transfer current setting/Change of ghost reduction setting
(Function code 45)**

■ **Changing return value of USB No.**

<Function>

When the operating system (OS) installed on the computer is Windows Vista[®], and the machine is connected to this computer using USB2.0FULL, the OS may not be able to obtain the USB device serial number depending on the computer and USB device. If the serial number cannot be obtained, the number of devices increases each time the device is connected to the computer. To avoid this problem, setting this function to “USBNo.=ON” can fix the USB No. return value to “0”.

LCD	Description
USBNo. =ON	Returns “0”.
USBNo. =OFF	Returns the serial number of the machine. (default)

“*” is displayed at the end of the currently specified function in the LCD display.

<Operating procedure>

- (1) Press the **4** and **5** keys in this order in the initial state of the maintenance mode. “USBNo.” is displayed on the LCD.
- (2) Press the **Mono Start** or **SET** key. “USBNo.=ON” is displayed on the LCD.
- (3) Press the **▲** or **▼** key to select “USBNo.=ON” or “USBNo.=OFF”, and press the **Mono Start** or **SET** key.
- (4) “Accepted” is displayed on the LCD, and the machine returns to the initial state of the maintenance mode.
- (5) Turn OFF the power switch of the machine.

Note:

This function is enabled when the power of the machine is turned OFF and ON.

■ Switching Dither Pattern

<Function>

This function is to switch the dither pattern when printed letters and/or slanted lines are not smooth, and thin lines are rough or uneven.

LCD	Description
PS.DitherType=0	Dither Pattern 0 is selected. (A dither pattern which improves roughness of letters and slanted lines) (default)
PS.DitherType=1	Dither Pattern 1 is selected. (A dither pattern which alleviates banding)

“*” is displayed at the end of the currently specified function in the LCD display.

<Operating procedure>

- (1) Press the **4** and **5** keys in this order in the initial state of the maintenance mode. “USBNo.” is displayed on the LCD.
- (2) Press the **▲** or **▼** key to display “PS.DitherType” and then press the **Mono Start** or **SET** key.
- (3) Press the **▲** or **▼** key to select “PS.DitherType=0” or “PS.DitherType=1”, and press the **Mono Start** or **SET** key.
- (4) “Accepted” is displayed on the LCD, and the machine returns to the initial state of the maintenance mode.

■ Switching of ON/OFF of DirectPrint Color mode-Improve Gray Color

<Function>

This function is to switch ON/OFF of the print control for the gray color when other colors are slightly blended in the gray color or the gray color is uneven upon printing.

LCD	Description
DP.ImpGray=ON	DirectPrint Color mode - Improve Gray Color. (Print control for gray color) ON (Improves the symptom that other colors are slightly blended in the gray color.) (default)
DP.ImpGray=OFF	DirectPrint Color mode - Improve Gray Color. (Print control for gray color) OFF (Improves the unevenness of the gray color.)

“*” is displayed at the end of the currently specified function in the LCD display.

<Operating procedure>

- (1) Press the **4** and **5** keys in this order in the initial state of the maintenance mode. “USBNo.” is displayed on the LCD.
- (2) Press the **▲** or **▼** key to display “DP.ImpGray” and then press the **Mono Start** or **SET** key.
- (3) Press the **▲** or **▼** key to select “DP.ImpGray=ON” or “DP.ImpGray=OFF”, and press the **Mono Start** or **SET** key.
- (4) “Accepted” is displayed on the LCD, and the machine returns to the initial state of the maintenance mode.

■ Switching of timing to execute Auto Registration

<Function>

Relative displacement between Cyan, Magenta, Yellow, and Black is detected using the registration mark sensor, and the Auto Registration is executed at the timing when the displacement value exceeds the stipulated threshold value.

This function is to switch the threshold value which is used as the timing to execute Auto Registration. The threshold value can be switched in three phases between High, Mid, and Low.

LCD	Description
Reg Freq=Mid	The frequency to execute Auto Registration is middle. (default)
Reg Freq=High	The frequency to execute Auto Registration is high.
Reg Freq=Low	The frequency to execute Auto Registration is low.

“*” is displayed at the end of the currently specified function in the LCD display.

Note:

It can be set regardless of the Auto Registration switching function in the function menu. Even if this function is switched, it does not affect the timing to execute Auto Registration in the function menu.

<Operating procedure>

- (1) Press the **4** and **5** keys in this order in the initial state of the maintenance mode. “USBNo.” is displayed on the LCD.
- (2) Press the **▲** or **▼** key to display “Regi Freq” and then press the **Mono Start** or **SET** key.
- (3) Press the **▲** or **▼** key to select “RegiFreq=Mid”, “RegiFreq=High” or “RegiFreq=Low”, and press the **Mono Start** or **SET** key.
- (4) “Accepted” is displayed on the LCD, and the machine returns to the initial state of the maintenance mode.

■ Adjusting left-end print start position on second side in duplex printing

<Function>

This function is to adjust the left-end print start position on the second side in the left and right direction if it is displaced in duplex printing. The adjustable range is -100 to 750 (unit: 300 dpi) (The minus direction means the left direction.)

<Operating procedure>

- (1) Press the **4** and **5** keys in this order in the initial state of the maintenance mode. “USBNo.” is displayed on the LCD.
- (2) Press the **▲** or **▼** key to display “DX.XAdjust” and then press the **Mono Start** or **SET** key. “DX.XAdjust=**” is displayed on the LCD.
- (3) To move the print start position to the left, press the **▼** key and decrease the value. To move the print start position to the right, press the **▲** key and increase the value.
- (4) When the value is changed to the adjustment value, press the **Mono Start** or **SET** key. “Accepted” is displayed on the LCD, and the machine returns to the initial state of the maintenance mode.

■ Change of the transfer current setting (Only for Japanese hagaki printing)

<Function>

Dots appeared when hagaki printing is performed can be alleviated by changing the transfer current setting.

<Operating procedure>

- (1) Press the **4** and **5** keys in this order in the initial state of the maintenance mode. "USBNo." is displayed on the LCD.
- (2) Press the **▲** or **▼** key to display "Special Printing" and then press the **Mono Start** or **SET** key. "Default" is displayed on the LCD.
- (3) Press the **▲** or **▼** key to change the setting, and press the **Mono Start** or **SET** key. There are four setting options: "Default", "HAGAKI1", "HAGAKI2", and "HAGAKI3". ("*" is displayed at the end of the currently specified function in the LCD display. The initial value is "Default".)
- (4) "Accepted" is displayed on the LCD, and the machine returns to the initial state of the maintenance mode.
- (5) Perform hagaki printing again to check if the dot symptom is alleviated.
- (6) If not, repeat the steps (1) to (4) to set an optimum option, and then perform hagaki printing.

■ Change of ghost reduction setting

<Function>

This function is a mode to reduce the level of ghost when it appears in low temperature and high humidity environment. If this function is turned ON, however, spots and dirt may appear on print.

LCD	Description
ON	Turn ON the ghost reduction function.
OFF	Turn OFF the ghost reduction function. (default)

"*" is displayed at the end of the currently specified function in the LCD display.

<Operating procedure>

- (1) Press the **4** and **5** keys in this order in the initial state of the maintenance mode. "USBNo." is displayed on the LCD.
- (2) Press the **▲** or **▼** key to display "Ghost Reduction" and then press the **Mono Start** or **SET** key.
- (3) Press the **▲** or **▼** key to select "ON" or "OFF", and press the **Mono Start** or **SET** key.
- (4) "Accepted" is displayed on the LCD, and the machine returns to the initial state of the maintenance mode.

1.3.16 Set country/language (Function code 52)

<Function>

This function is user accessible, and is used to customize the EEPROM according to the language, function settings, and worker switch settings.

Note:

This function is applied to “France Belgium Netherlands”, “Pan-Nordic”, “East Europe”, “Oceania”, and “Iberia” only.

<Operating procedure>

- (1) Press the **5** and **2** keys in this order in the initial state of the maintenance mode.
“Set Country” is displayed on the LCD.
- (2) Press the country you want to set on the LCD and press the **OK** key.
- (3) Press the **Yes** key on the LCD.
- (4) The new setting is saved. After the machine finishes saving the new settings, it returns to the initial state of the maintenance mode.

France Belgium Netherlands	Oceania	Pan-Nordic	Iberia	East Europe	South Africa Turkey Gulf
France	Australia	Norge	Italia	Cheska republika	South Africa
België/ Belgique	New Zealand	Sverige	España	Magyarország	Türkiye
Nederland		Suomi	Portugal	Polska	Others
		Danmark		България	
		Others		România	
				Slovensko	
				Slovenija	
				Hrvatska	
				Others	

1.3.17 Transfer of received fax data and log information (Function code 53)

<Function>

When the machine is unable to print the received fax data due to an error current in the printing mechanism, this function is used to transfer the data to another machine. The communication management report, communication list, or machine log information can also be transferred.

Note:

- Up to 99 files can be transferred simultaneously. When you transfer 100 files or more, perform the following procedure multiple times.
- If there are both color and monochrome data the monochrome data will be transferred first. If the receiver machine does not support the color function, the sender machine cannot transfer color data, resulting in an error.

<Operating procedure>

- (1) Press the **5** and **3** keys in this order in the initial state of the maintenance mode.
"FAX TRANSFER" is displayed on the LCD.
 - To check the number of received files, press the **1** key.
"1.NO. OF JOBS" is displayed on the LCD.
Press the **SET** key, and the number of received files appears, just as "NO. OF JOBS: 10".
 - To transfer the activity report only, press the **2** key.
"2.ACTIVITY" is displayed on the LCD.
 - To transfer received files (together with the activity report), press the **3** key.
"3.DOCUMENTS" is displayed on the LCD.
Note that if there is no received file, the "NO DOCUMENTS" appears on the LCD.
 - To transfer the communication list for the latest communication, press the **4** key.
"4.COM.LIST (NEW)" is displayed on the LCD.
 - To transfer the communication list for last three errors, press the **5** key.
"5.COM.LIST (ERR3)" is displayed on the LCD.
 - To transfer the maintenance information (the list in Function code 77), press the **6** key.
"6.MNT77 LIST" is displayed on the LCD.
- (2) With the "2.ACTIVITY," "3.DOCUMENTS," "4.COM.LIST (NEW)," "5.COM.LIST (ERR3)" or "6.MNT77 LIST" being displayed, press the **SET** key. "ENTER NO. & SET" is displayed on the LCD.
- (3) Enter the telephone number of the receiver machine and press the **SET** key again.
- (4) The machine displays the "Accepted" for approximately two seconds and starts dialing to transfer data.

Note:

- Be sure to type the telephone number with the numerical keys. No one-touch dialing is allowed in this procedure.
- No station ID will be attached. A cover page and end page as shown on the [next page](#) will be automatically attached, instead.

■ Cover page sample

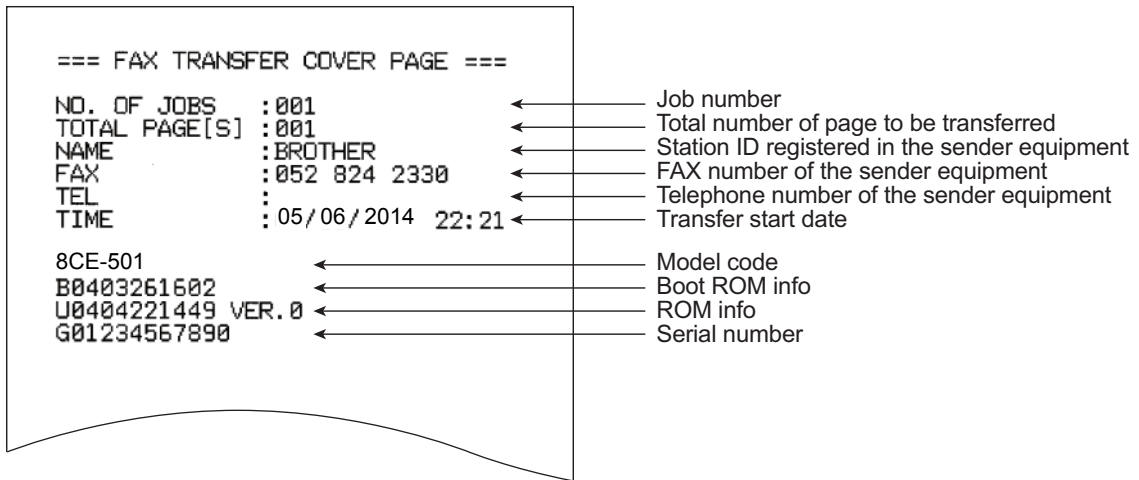

Fig. 5-10

■ End page sample

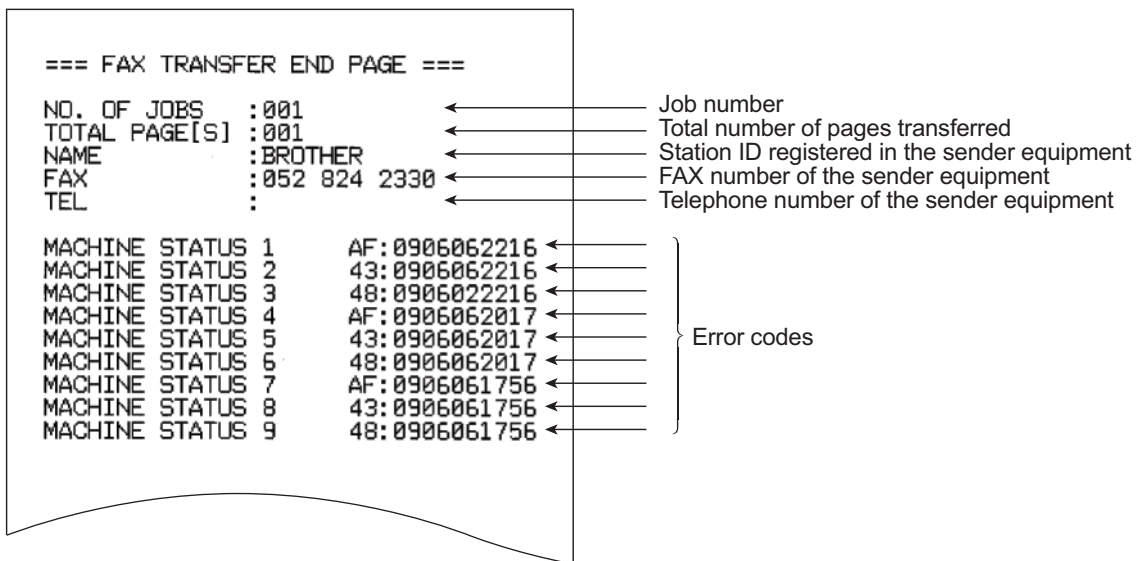

Fig. 5-11

1.3.18 Fine adjustment of scan positions (Function code 54)

<Function>

This function is used to adjust the scanning start/end positions.

<Operating procedure>

- (1) Press the **5** and **4** keys in this order in the initial state of the maintenance mode.
For duplex scanning model, “▲ : ADF ▼ : FB” is displayed on the LCD. If you want to adjust the scanning position of the ADF, press the ▲ key. If you want to adjust scanning position of the FB, press the ▼ key, and go to step (2).
For single-side scanning model, go to step (2).
- (2) Press the ▲ key to increase the correction value and the ▼ key to lower it.

Note:

Press the **X** key, and the machine returns to the initial state in the maintenance mode without changing the correction value.

- (3) When the adjustment is finished, press the **SET** key. “Accepted” is displayed on the LCD, and the machine returns to the initial state of the maintenance mode.

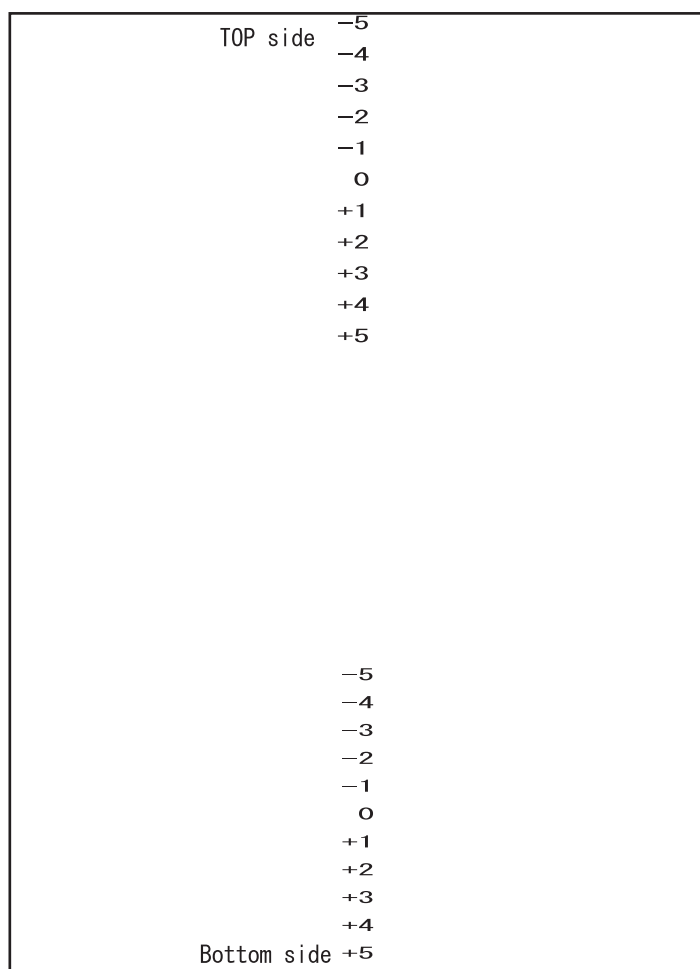

Fig. 5-12

1.3.19 Acquisition of white level data and setting of CIS scanning area (Function code 55)

<Function>

This function is used to acquire the white level of CIS scanner and save it together with the scanning area into EEPROM of the main PCB.

<Operating procedure>

- (1) Press the **5** key twice in the initial state of the maintenance mode. "Press START" is displayed on the LCD.
- (2) Press the **Mono Start** key. "SCANNER AREA SET" is displayed on the LCD and the white level data is acquired.
- (3) After a few seconds, the machine saves the correction of the white level data/scanning width in the EEPROM, and returns to the initial state of the maintenance mode. If an error is detected during this operation, the message "SCANNER ERROR" is displayed on the LCD for single-side scanning model, and the message "SCANNER ERR ADF" or "SCANNER ERR FB" is displayed on the LCD for duplex scanning model.

If this occurs, press the **X** key to return the machine to the initial state of the maintenance mode.

1.3.20 Motor reset (Function code 57)

<Function>

When the main PCB or each motor is replaced, the main PCB needs to identify each motor. If you reset the identification of each motor in the main PCB with this function, when the power is turned ON next time, a motor identification operation for each motor is performed before the engine performs a warm-up.

<Operating procedure>

- (1) Press the **5** and **7** keys in this order in the initial state of the maintenance mode.
“RESET MOTOR” is displayed on the LCD.
- (2) When the **Mono Start** key is pressed, each motor identification result is reset and “PLZ POWER OFF/ON” is displayed on the LCD.
- (3) Turn OFF/ON the power switch to perform a motor identification operation for each motor and the machine returns to the initial state of the maintenance mode.

Note:

If “PLZ POWER OFF/ON” is displayed on the LCD, any keys other than the power switch are not accepted.

1.3.21 Adjustment of touch panel (Function code 61)

<Function>

This function is used to adjust the detection area on the touch panel.

Note:

This adjustment requires a touch panel stylus with a thin tip. A commercially available stylus designed for electronic dictionaries or personal digital assistance (PDA) can be used. If you do not have it on hand, order the "TOUCH PEN" from the Brother's parts list.

<Operating procedure>

- (1) Press the **6** and **1** keys in this order in the initial state of the maintenance mode.
The adjustment screens shown below are displayed on the LCD.
- (2) Touch the center of the symbol on the top left of the screen with a touch panel stylus.
The symbol is not displayed upon touching it. Then touch the symbol on the bottom left.
In the same way, touch the symbols on bottom right, top right, and center in this order.

Note:

- Do not use tools other than a touch panel stylus. Especially, never use a pointed one, e.g., a screwdriver. Using such a tool damages the touch panel.
- When performing this adjustment, do not touch the panel with your fingers. Doing so deteriorates detection accuracy and correct adjustment cannot be obtained.
- If no operation is performed for one minute or the **X** key is pressed, the machine returns to the initial state of the maintenance mode.

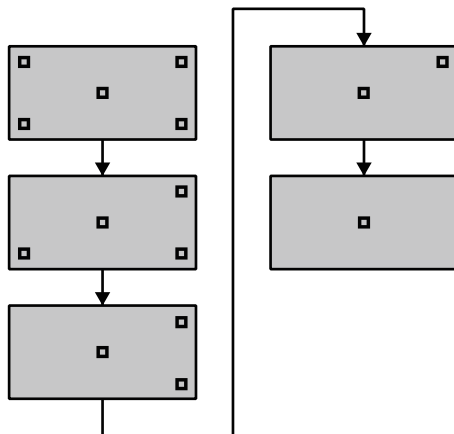

Fig. 5-13

- (3) When you press the symbol at the center (the 5th symbol), "OK" is displayed if the specified area is correctly adjusted. Then, the machine returns to the initial state of the maintenance mode.

Note:

If "NG" is displayed on the LCD and "NG" is displayed again when repeating this adjustment twice or three times, check the touch panel flat cable for connection failure. If "NG" is displayed in spite of the proper connection of the harness, replace the control panel ASSY.

1.3.22 Adjustment of color registration (Adjustment of inter-color position alignment) (Function code 66)

<Function>

This function allows service personnel to forcibly activate the adjustment of color registration (adjustment of inter-color position alignment) function which is usually executed automatically under a specified condition. If adjustment of inter-color position alignment (auto) fails because toner reaches its life, etc, you can adjust inter-color position alignment manually. The end users are allowed to perform “Adjustment of inter-color position alignment without registration sensor calibration (auto)”, “Printing of misregistration correction chart” and “Adjustment of inter-color position alignment (manual)” only.

Note:

If an error occurs after executing Maintenance mode 66, upgrade the firmware to the latest one. (Refer to “1.1 Installing the Firmware (Sub Firmware, Panel Firmware, Main Firmware, and High-voltage Firmware)” in Chapter 4.) After upgrading the firmware, execute Maintenance mode 66 again.

This function has the following functions.

Function	Description	LCD
Adjustment of inter-color position alignment without registration sensor calibration (auto)	Automatically correct misregistration between colors that occurs as the number of printed pages increases and time passes.	REGISTRATION
Printing of misregistration correction chart	Print the chart that you check for an input value when manually correcting misregistration between colors.	PRINT CHART
Input of sensor offset value	Unavailable for maintenance work.	OFFSET ADJUST
Adjustment of inter-color position alignment (manual)	Using the chart, manually correct misregistration between colors that occurs as the number of printed pages increases and time passes. This is performed when automatic adjustment fails.	SET REGISTRATION
Adjustment of inter-color position alignment including registration sensor calibration (auto)	After the sensitivity adjustment of registration sensor, correct misregistration between colors that occurs as the number of printed pages increases and time passes.	ADD REGISTRATION

■ Adjustment of inter-color position alignment without registration sensor calibration (auto)

<Operating procedure>

- (1) Press the **6** key twice in the initial state of the maintenance mode. "REGISTRATION" is displayed on the LCD.
- (2) Press the **SET** key. "PLS WAIT 66-1" is displayed on the LCD, and adjustment of inter-color position alignment is automatically done.
- (3) When this operation is completed without an error, "COMPLETED" is displayed on the LCD.
- (4) Press the **X** key to return the machine to the initial state of the maintenance mode.

Note:

If the Adjustment of inter-color position alignment without registration sensor calibration (auto) fails while being in process, "ERROR 66-1" is displayed on the LCD. Refer to the error message list in the table below for the troubleshooting.

■ Error message list

Error message	Measure
FAILED REGIST	Press the Mono Start key to clear the error. Perform the Adjustment of inter-color position alignment (auto) again. If the error recurs, clean the belt unit and the drum unit and then perform the adjustment again. If the error still recurs, replace the belt unit and the drum unit.
TONER EMPTY # *	Replace the empty toner cartridge and press the Mono Start key to clear the error. Perform the Adjustment of inter-color position alignment (auto) again.
NG * L:C080 R:M105	Press the Mono Start key to clear the error. Perform the Adjustment of inter-color position alignment (auto) again.
NG R-L:C030	
NG PWM L120 R180	
NG PWM R-L:080	
NG CNT R100 L100	
NG S-POSI R:080	
NG SKEW:120	
NG PWM R-P L:080	
NG XMARGIN:M191	
Cover is Open	

* # indicates the toner color (Y, M, or C) of which cartridge became empty.

■ Printing of misregistration correction chart

<Operating procedure>

- (1) Press the **6** key twice in the initial state of the maintenance mode. "REGISTRATION" is displayed on the LCD.
- (2) Press the **▲** or **▼** key to display "PRINT CHART" on the LCD.
- (3) Press the **SET** key. "PRINTING" is displayed on the LCD, and misregistration correction chart (see the figure below) is printed. When printing is finished, "PRINT CHART" is displayed on the LCD.
- (4) Press the **X** key to return the machine to the initial state of the maintenance mode.

■ Misregistration correction chart

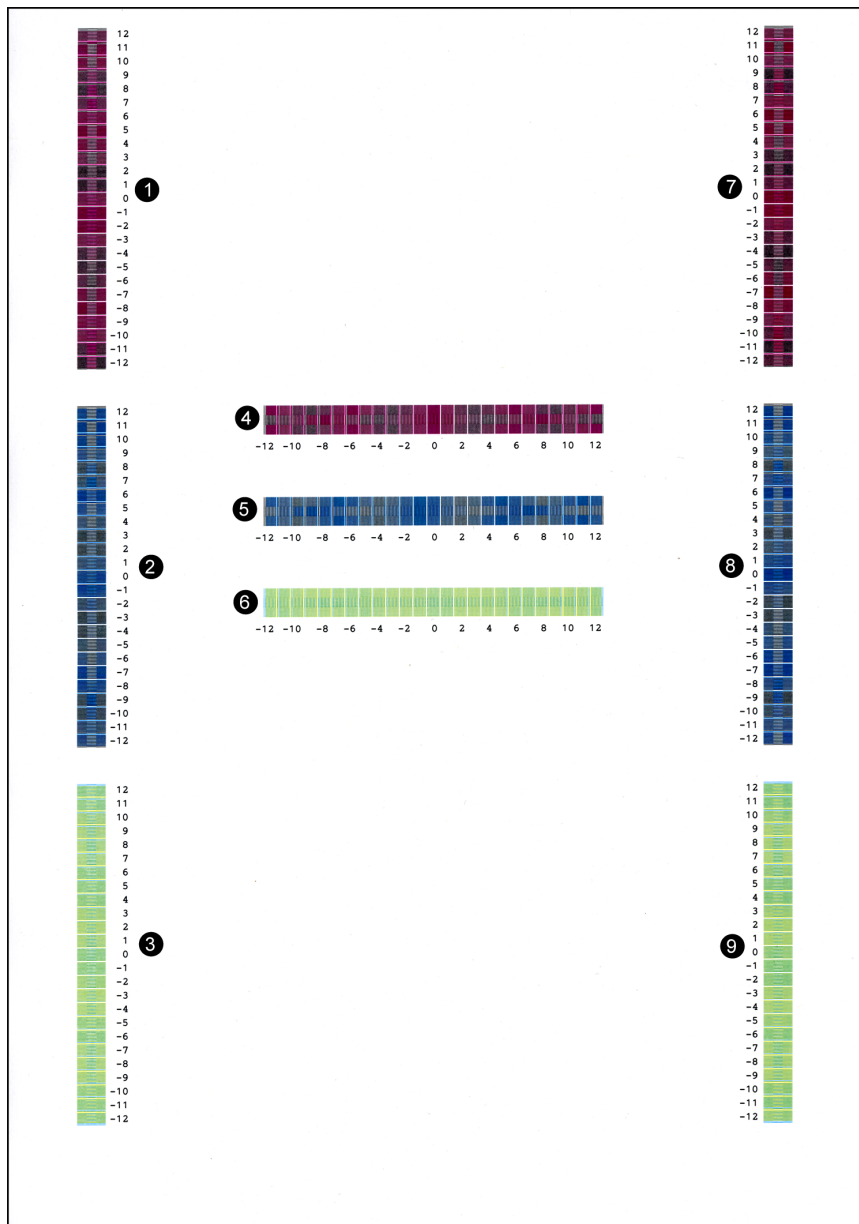

Fig. 5-14

■ Adjustment of inter-color position alignment (manual)

<Operating procedure>

- (1) Press the **6** key twice in the initial state of the maintenance mode. "REGISTRATION" is displayed on the LCD.
- (2) Press the **▲** or **▼** key to display "SET REGISTRATION" on the LCD.
- (3) Press the **SET** key. "1. MAGENTA=0" is displayed on the LCD. Using the misregistration correction chart printed by "■ Misregistration correction chart", identify the numeric value whose color is the darkest in the pattern of (1) (Magenta Left). Press the **▲** or **▼** key to display the identified numeric value.
- (4) Press the **SET** key, and enter each numeric value of the patterns (2) to (9) in the same way.
- (5) When you enter the numeric value of the pattern (9) (Yellow Right), "COMPLETED" is displayed on the LCD.
- (6) Press the **X** key to return the machine to the initial state of the maintenance mode.

■ Adjustment of inter-color position alignment including registration sensor calibration (auto)

<Operating procedure>

- (1) Press the **6** key twice in the initial state of the maintenance mode. "REGISTRATION" is displayed on the LCD.
- (2) Press the **▲** or **▼** key to display "ADD REGISTRATION" on the LCD.
- (3) Press the **SET** key. "PLS WAIT 66-1" is displayed on the LCD and sensitivity adjustment of registration sensor and adjustment of inter-color position alignment are performed automatically.
- (4) When this operation is completed without an error, "COMPLETED" is displayed on the LCD.
- (5) Press the **X** key to return the machine to the initial state of the maintenance mode.

Note:

If the Adjustment of inter-color position alignment including registration sensor calibration (auto) fails while being in process, "ERROR 66-1" is displayed on the LCD. Refer to the error message list on [P5-41](#) for the troubleshooting.

1.3.23 Continuous print test (Function code 67)

<Function>

This function is used to conduct paper feed and eject tests while printing patterns.

<Operating procedure>

- (1) Press the **6** and **7** keys in this order in the initial state of the maintenance mode. "SELECT: K 100%" is displayed on the LCD.
- (2) Referring to the <Print pattern> table, press the ▲ or ▼ key to select the desired print pattern and press the **SET** key. "SELECT: A4" is displayed on the LCD.
- (3) Referring to the <Paper size> table, press the ▲ or ▼ key to select the desired paper size and press the **SET** key. "SELECT: PLAIN" is displayed on the LCD.
- (4) Referring to the <Print specifications> table, press the ▲ or ▼ key to select the desired media specifications and press the **SET** key. "SELECT: TRAY1 SX" is displayed on the LCD.
- (5) Referring to the <Print type> table, press the ▲ or ▼ key to select the desired print type and press the **SET** key. "SELECT: 1PAGE" is displayed on the LCD.
- (6) Referring to the <Number of pages to be printed> table, press the ▲ or ▼ key to select the desired number of pages to be printed and press the **SET** key. For the intermittent pattern printing only, "SELECT: 1P/JOB" is displayed on the LCD. For other than intermittent pattern printing, go to step (8).
- (7) Referring to the <Number of pages per job> (Intermittent pattern printing only) table, press the ▲ or ▼ key to select the desired number of pages per job and press the **SET** key.
- (8) "PAPER FEED TEST" is displayed on the LCD and the test pattern starts to be printed under the selected items for paper feed test.
- (9) If you press the **X** key, printing of test pattern is interrupted and the machine returns to the initial state of the maintenance mode.

<Print pattern>

LCD	Description
SELECT: K 100%	Black 100% solid print
SELECT: C 100%	Cyan 100% solid print
SELECT: M 100%	Magenta 100% solid print
SELECT: Y 100%	Yellow 100% solid print
SELECT: W 100%	White 100% solid print
SELECT: R 100%	Red 100% solid print
SELECT: G 100%	Green 100% solid print
SELECT: B 100%	Blue 100% solid print
SELECT: KCMY1%	Black/Cyan/Magenta/Yellow 1% intermittent pattern print *
SELECT: KCMY5%	Black/Cyan/Magenta/Yellow 5% intermittent pattern print *
SELECT: Lattice	Lattice print
SELECT: Total	Total pattern print

* Up to 500 sheets in one-sided printing and 1,000 sheets in two-sided printing in the case of job printing.

<Paper size>

LCD	Description
SELECT: A4	A4-size
SELECT: LETTER	Letter-size
SELECT: ISOB5	ISO B5-size
SELECT: JISB5	JIS B5-size
SELECT: A5	A5-size
SELECT: A5L	A5L-size
SELECT: JISB6	JIS B6-size
SELECT: A6	A6-size
SELECT: EXECUTE	Executive-size
SELECT: LEGAL	Legal-size
SELECT: FOLIO	Folio-size
SELECT: HAGAKI	Postcard-size

<Print specifications>

LCD	Description
SELECT: PLAIN	Plain paper
SELECT: THICK	Thick paper
SELECT: THIN	Thin paper
SELECT: THICKER	Thicker paper
SELECT: RECYCLED	Recycled paper
SELECT: BOND	Bond paper
SELECT: LABEL	Label
SELECT: ENVELOPE	Envelopes
SELECT: ENVTHIN	Env. Thin
SELECT: ENVTHICK	Env. Thick
SELECT: GLOSSY	Glossy paper
SELECT: HAGAKI	Postcard

<Print type>

LCD	Description
SELECT: TRAY1 SX	One-sided printing from Paper tray 1
SELECT: TRAY2 SX	One-sided printing from T2 paper tray unit
SELECT: MP SX	One-sided printing from MP tray
SELECT: TRAY1 DX	Two-sided printing from Paper tray 1
SELECT: TRAY2 DX	Two-sided printing from T2 paper tray unit
SELECT: MP DX	Two-sided printing from MP tray

<Number of pages to be printed>

LCD	Description
SELECT: 1PAGE	One page printing
SELECT: CONTINUE	Continuous printing
SELECT: JOB	Intermittent printing by each unit *

* Selectable only when "KCMY1%" or "KCMY5%" is selected as print pattern and a tray other than the MP tray is selected as print type.

<Number of pages per job> (Intermittent pattern printing only)

LCD	Description
SELECT: 1P/JOB	Printing 1 page per job ^{*1}
SELECT: 2P/JOB	Printing 2 page per job ^{*1}
SELECT: 5P/JOB	Printing 5 page per job ^{*1}
SELECT: 2I/JOB	Printing 2 images per job ^{*2}
SELECT: 5I/JOB	Printing 5 images per job ^{*2 *3}
SELECT: 10I/JOB	Printing 10 images per job ^{*2}

^{*1} Selectable only when SX is selected as print type.

^{*2} Selectable only when DX is selected as print type.

^{*3} One-sided printing for the 5th page.

■ Print pattern

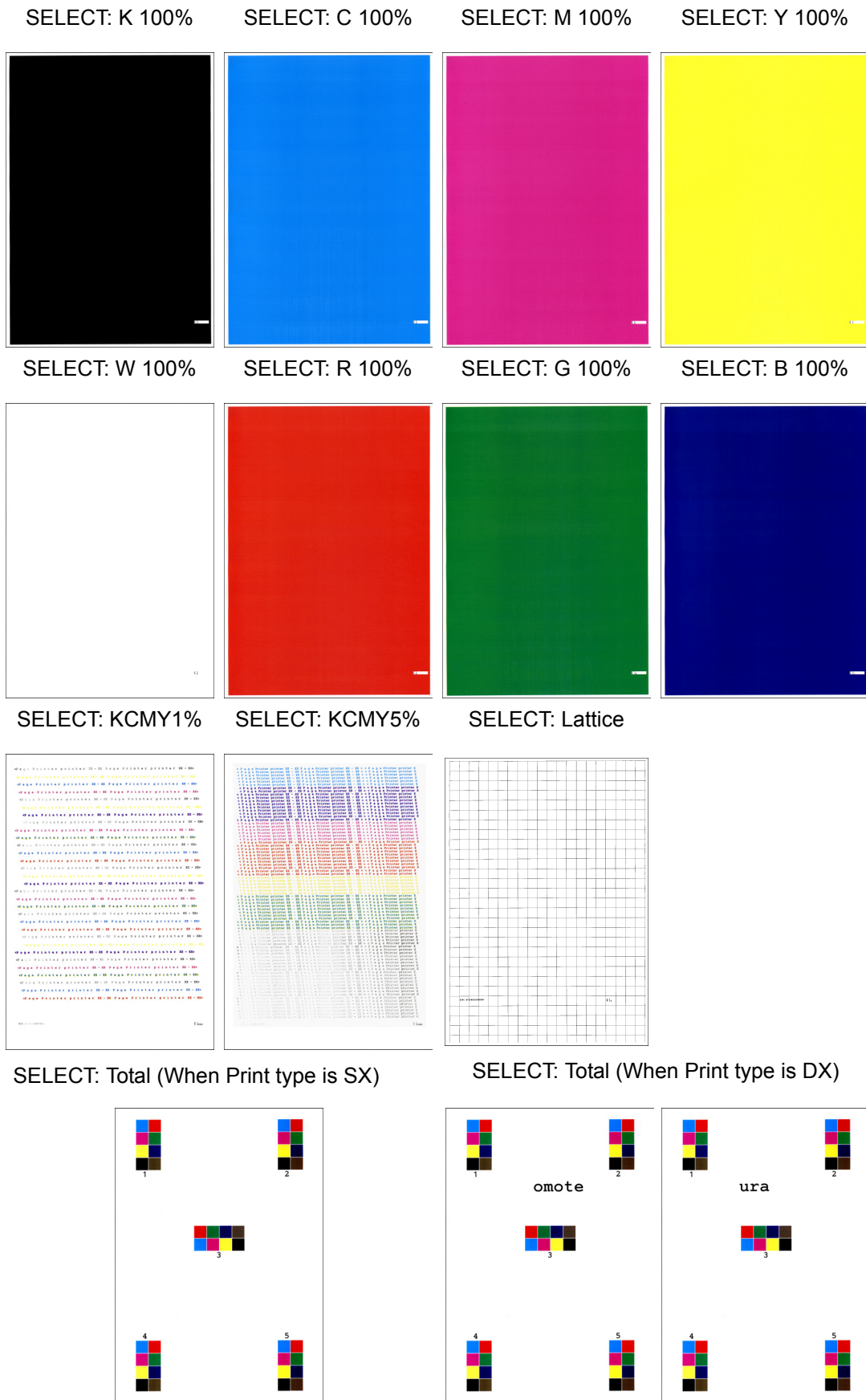

Fig. 5-15

1.3.24 Laser unit test pattern print (Function code 68)

<Function>

This function is used to print the laser unit test patterns and check if there is any failure in the laser unit.

<Operating procedure>

- (1) Press the **6** and **8** keys in this order in the initial state of the maintenance mode. "PRINTING" is displayed on the LCD, and one laser unit test pattern (see the figure below) is printed.
- (2) When this operation is completed without an error, "SCANNER CHECK" is displayed on the LCD.
- (3) Press the **X** key and finish this operation to return the machine to the initial state of the maintenance mode.

Note:

When printing fails, the following error indications are displayed on the LCD. When the error factors are removed and the **Mono Start** key is pressed, the machine automatically recovers to the re-executable state. "PRINTING" is displayed on the LCD, and the Laser unit test pattern is printed on a sheet.

Error message	Measure
Replace Toner # *	Replace the empty toner cartridge and press the Mono Start key to clear the error.
Cover is Open	Close the front cover.
No Paper	Load paper into the paper tray, close the paper tray, and press the Mono Start key to clear the error.
Jam Tray1	Remove the jammed paper, close the paper tray and all the covers, and press the Mono Start key to clear the error.
Jam Rear	

* # indicates the toner color (K, Y, M, or C) of which cartridge became empty.

■ Laser unit test pattern



Fig. 5-16

1.3.25 Frame pattern print (One-sided) (Function code 69)

<Function>

This function is used to print one page of the frame pattern of the external circumference in one-sided printing and check if there is any deviation or omission of print.

<Operating procedure>

- (1) Load the paper whose size matches the default paper setting (A4 or Letter) into the paper tray.
- (2) Press the **6** and **9** keys in this order in the initial state of the maintenance mode.
“PRINTING” is displayed on the LCD, and the frame pattern (see the figure below) is printed on a single side of the paper.
- (3) When print is completed, “WAKU SX” is displayed on the LCD.
- (4) Press the **X** key and finish this operation to return the machine to the initial state of the maintenance mode.

Note:

If printing fails, the following error indications are displayed on the LCD, and printing is cancelled. To print again, refer to the measures in the table below and remove the cause of the error. Then, press the **Mono Start** key. “PRINTING” is displayed on the LCD, and the frame pattern is printed on a single sheet.

Error message	Measure
Replace Toner	Replace the empty toner cartridge and press the Mono Start key to clear the error.
Cover is Open	Close the front cover.
No Paper	Load paper into the paper tray, close the paper tray, and press the Mono Start key to clear the error.
Jam Tray1	Remove the jammed paper, close the paper tray and all the covers, and press the Mono Start key to clear the error.
Jam Rear	

■ Frame pattern



Fig. 5-17

1.3.26 Frame pattern print (Two-sided) (Function code 70)

<Function>

This function is used to print one page of the frame pattern of the external circumference in two-sided printing and check if there is any deviation or omission of print.

<Operating procedure>

- (1) Load the paper whose size matches the default paper setting (A4 or Letter) into the paper tray.
- (2) Press the **7** and **0** keys in this order in the initial state of the maintenance mode. "PRINTING" is displayed on the LCD, and the frame pattern (see the figure below) is printed on both sides of the paper.
- (3) When print is completed, "WAKU DX" is displayed on the LCD.
- (4) Press the **X** key to return the machine to the initial state of the maintenance mode.

Note:

If printing fails, the following error indications are displayed on the LCD, and printing is cancelled. To print again, refer to the measures in the table below and remove the cause of the error. Then, press the **Mono Start** key. "PRINTING" is displayed on the LCD, and the frame pattern is printed on a single sheet.

Error message	Measure
Replace Toner	Replace the empty toner cartridge and press the Mono Start key to clear the error.
Cover is Open	Close the front cover.
No Paper	Load paper into the paper tray, close the paper tray, and press the Mono Start key to clear the error.
Jam Tray1	Remove the jammed paper, close the paper tray and all the covers, and press the Mono Start key to clear the error.
Jam Rear	
Jam Duplex	
Duplex Disabled	Load paper into the paper tray, close the paper tray and all the covers, and press the Mono Start key to clear the error.

■ Frame pattern

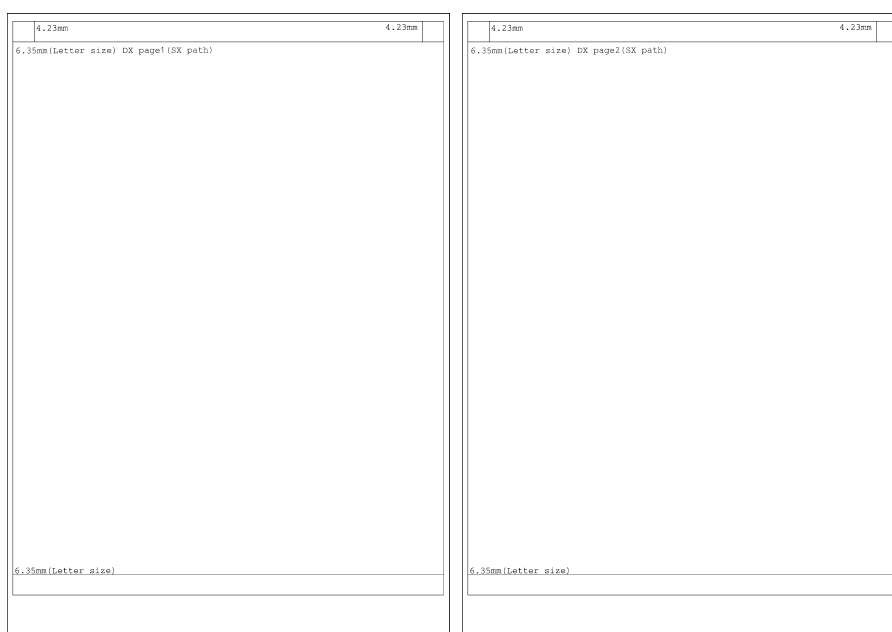

Fig. 5-18

1.3.27 Color test pattern (Function code 71)

<Function>

This function is used to print the pattern of each color and check if there is any dirty on or failure in the belt unit, developer roller, and exposure drum, etc.

<Operating procedure>

- (1) Press the **7** and **1** keys in this order in the initial state of the maintenance mode. "2D3S YMCBWKW_A" is displayed on the LCD.
- (2) Referring to the <Print pattern> table, press the ▲ or ▼ key to select the desired print pattern and press the **SET** key. When "2D3S YMCBWKW_A" is selected, "PRINTING" is displayed on the LCD and a test pattern printing is started. When a print pattern other than "2D3S YMCBWKW_A" is selected, "SELECT: A4" is displayed on the LCD. (Following steps (3) to (6) described below, select an option in each item and perform test pattern printing.)
- (3) Referring to the <Paper size> table, press the ▲ or ▼ key to select the desired paper size and press the **SET** key. "SELECT: PLAIN" is displayed on the LCD.
- (4) Referring to the <Print specifications> table, press the ▲ or ▼ key to select the desired media specifications and press the **SET** key. "SELECT: SX" is displayed on the LCD.
- (5) Referring to the <Print type> table, press the ▲ or ▼ key to select the desired print type and press the **SET** key. "SELECT: 1PAGE" is displayed on the LCD.
- (6) Referring to the <Number of pages to be printed> table, press the ▲ or ▼ key to select the desired number of pages to be printed and press the **SET** key. "PRINTING" is displayed on the LCD and the test pattern starts to be printed under the selected items for paper feed test.
- (7) When printing is finished, the screen returns to the print pattern display. To print the test pattern again, press the **Mono Start** key.
- (8) Press the **X** key to return the machine to the initial state of the maintenance mode.

Note:

If printing fails, the error indications in the <Error message> table are displayed on the LCD and printing is cancelled. To print again, refer to the measures in the table and remove the cause of the error. Then, press the **Mono Start** key. "PRINTING" is displayed on the LCD and the color test pattern is printed.

<Print pattern>

LCD	Description
2D3S YMCBWKW_A	Total seven sheets of one sheet for each color with full page print mode* + two blank sheets + data to check Banding
2D3S M	Magenta
2D3S K	Black
2D3S C	Cyan
2D3S Y	Yellow
2D3S MCKY	4-color horizontal band

* In the full page print mode, the cleaning operation is performed between printing of blank paper and Black.

<Paper size>

LCD	Description
SELECT: A4	A4-size
SELECT: LETTER	Letter-size
SELECT:ISOB5	ISO B5-size
SELECT:JISB5	JIS B5-size
SELECT:A5	A5-size
SELECT:A5L	A5L-size
SELECT:JISB6	JIS B6-size
SELECT:A6	A6-size
SELECT:EXECUTE	Executive-size
SELECT:LEGAL	Legal-size
SELECT:FOLIO	Folio-size
SELECT:HAGAKI	Postcard-size

<Print specifications>

LCD	Description
SELECT: PLAIN	Plain paper
SELECT: THICK	Thick paper
SELECT: THIN	Thin paper
SELECT:THICKER	Thicker paper
SELECT:RECYCLED	Recycled paper
SELECT:BOND	Bond paper
SELECT:LABEL	Label
SELECT:ENVELOPE	Envelopes
SELECT:ENVTHIN	Env. Thin
SELECT:ENVTHICK	Env. Thick
SELECT:GLOSSY	Glossy paper
SELECT:HAGAKI	Postcard

<Print type>

LCD	Description
SELECT: SX	One-sided printing from Paper tray 1
SELECT: DX	Two-sided printing from Paper tray 1

<Number of pages to be printed>

LCD	Description
SELECT: 1PAGE	One page printing
SELECT: CONTINUE	Continuous printing

<Error message>

LCD	Measure
Replace Toner	Replace the empty toner cartridge and press the Mono Start key to clear the error.
Cover is Open	Close the front cover.
No Paper	Load paper into the paper tray, close the paper tray, and press the Mono Start key to clear the error.
Jam Tray1	Remove the jammed paper, close the paper tray and all the covers, and press the Mono Start key to clear the error.
Jam Rear	

■ Color test pattern

2D3S YMCBWKW_A

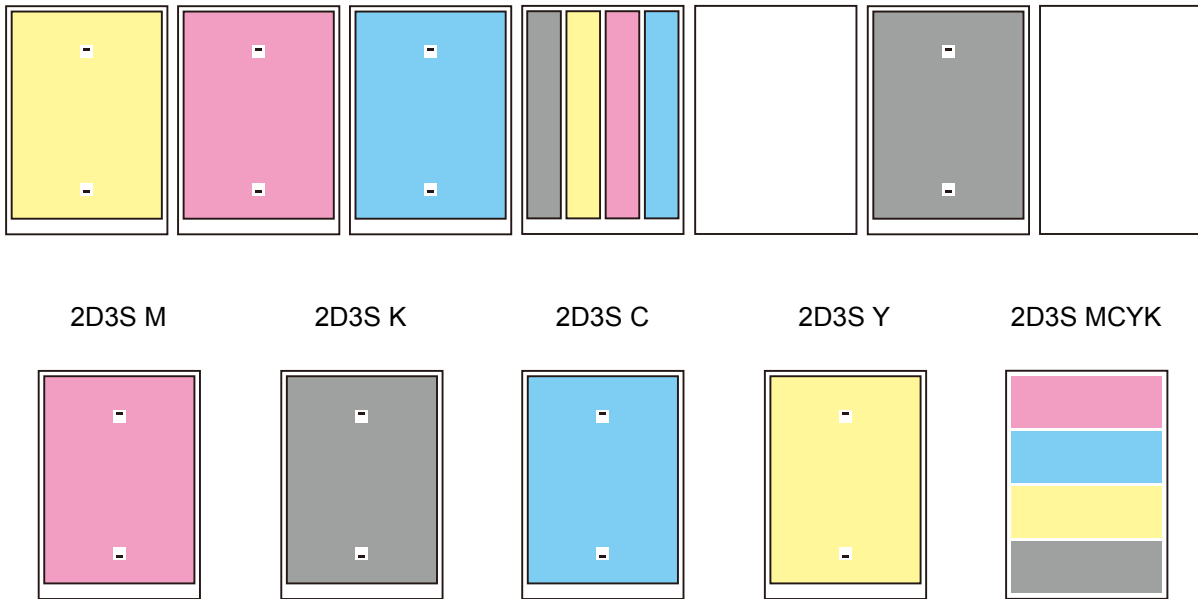

Fig. 5-19

1.3.28 Sensitivity adjustment of density sensor (Function code 72)

<Function>

This function is used to print the patch data for density sensor sensitivity adjustment on the belt unit and measure the density with the density sensor. The characteristics of the density sensor are calculated based on the value measured by the density sensor, and the parameter for correcting developing bias voltage is adjusted.

<Operating procedure>

- (1) Press the **7** and **2** keys in this order in the initial state of the maintenance mode. "PLS WAIT 72" is displayed on the LCD and performs the sensitivity adjustment of the density sensor.
- (2) When this operation is completed without errors, the machine returns to the initial state of the maintenance mode.

Note:

If the sensitivity adjustment of the density sensor fails, "ERROR 72" is displayed on the LCD. Display the error message by pressing the ▼ key, and take the following measure that corresponds to the error message.

Error message	Measure
dens_l_drk_err	<ul style="list-style-type: none"> - Reconnect the harness of the eject sensor PCB. - Replace the registration mark sensor unit. - Replace the main PCB ASSY.
belt_err	<ul style="list-style-type: none"> - Replace the belt unit. - Replace the waste toner box. - Replace the registration mark sensor unit. - Replace the main PCB ASSY.
dens_pat_err dens_calc_err	<ul style="list-style-type: none"> - Check if the toner cartridges are set in the correct order of colors. - Replace the toner cartridges and drum unit. - Replace the registration mark sensor unit. - Replace the main PCB ASSY.
dens_led_adj_err	<ul style="list-style-type: none"> - Replace the belt unit. - Replace the waste toner box. - Replace the registration mark sensor unit. - Replace the main PCB ASSY.
lph_calc_err	<ul style="list-style-type: none"> - Replace the toner cartridges and drum unit. - Securely close the front cover. - Wipe the scanner window of the laser unit with a soft lint-free cloth. - Re-assemble the laser unit.
TONER EMPTY # *	Replace the empty toner cartridge and press the Mono Start key to clear the error. Perform the sensitivity adjustment of the density sensor again.
Cover is Open	Close the front cover.
Replace Toner	Replace the black toner cartridge and press the Mono Start key to clear the error. Perform the sensitivity adjustment of the density sensor again.

* # indicates the toner color (Y, M, or C) of which cartridge became empty.

1.3.29 Continuous adjustments of density and registration sensor (Function code 73)

<Function>

This function is used to perform the following functions consecutively:

Sensitivity adjustment of density sensor (Function code 72), Developing bias voltage correction (Function code 83), and Adjustment of color registration (Adjustment of inter-color position alignment) including registration sensor calibration (Function code 66).

<Operating procedure>

- (1) Press the **7** and **3** keys in this order in the initial state of the maintenance mode.
“72/83/66-1” is displayed on the LCD.
- (2) Press the **SET** key. “PLS WAIT 72” is displayed on the LCD and each adjustment is performed in the following order.
 - 1) Sensitivity adjustment of density sensor (Function code 72)
LCD: PLS WAIT 72
 - 2) Developing bias voltage correction (Function code 83)
LCD: PLS WAIT 83
 - 3) Adjustment of color registration (Adjustment of inter-color position alignment) including registration sensor calibration (Function code 66)
LCD: PLS WAIT 66-1
- (3) When all operations are completed, “COMP” is displayed on the LCD.
Pressing the **▼** key and **X** key in this order and the machine returns to the initial state of the maintenance mode.

Note:

If each adjustment fails, “ERROR**” is displayed on the LCD and the adjustment is stopped. If you press the **▼** key with “ERROR**” displayed, the details of the error are shown. “**” in “ERROR **” displayed on the LCD indicates corresponding function code number. Make sure to take an appropriate measure after checking the measures provided in each function code.

1.3.30 Setting by country (Function code 74)

<Function>

This function is used to customize the machine according to language, function settings, and worker switch settings.

<Operating procedure>

- (1) Press the **7** and **4** keys in this order in the initial state of the maintenance mode.
The present spec code is displayed on the LCD.
- (2) Enter the desired spec code (fourth digits).
- (3) When you press the **Mono Start** key, the new setting is saved, and "PARAMETER INIT" is displayed on the LCD. After the setting is saved, the machine returns to the initial state of the maintenance mode.

Note:

If there is a pause of more than one minute, the machine will automatically return to the initial state of the maintenance mode.

<Spec code>

MODEL	Spec code		Spec code (Detail)	
DCP-L8400CDN	Brazil	0042	---	---
	CEE-General	1004	---	---
	China	0020	---	---
	France/Belgium/Netherlands	1058	Belgium	1008
			France	1004
			Netherlands	1004
			Others	1004
	Germany	3004	---	---
	Italy/Iberia	1004	---	---
	Pan-Nordic	1004	---	---
	Switzerland	1004	---	---
UK	1004	---	---	
DCP-L8450CDW	CEE-General	1104	---	---
	France/Belgium/Netherlands	1158	Belgium	1108
			France	1104
			Netherlands	1104
			Others	1104
	Germany	3104	---	---
	Italy/Iberia	1104	---	---
	Italy-CONSIP	9104	---	---
	Pan-Nordic	1104	---	---
	Switzerland	1104	---	---
UK	1104	---	---	
MFC-L8600CDW	Australia/New Zealand	0256	Australia	0206
			New Zealand	0227
	Brazil	0242	---	---
	Canada	0202	---	---
	Gulf	0274	Gulf	0241
			South Africa	0224
			Turkey	0225
	Korea	0244	---	---
	Taiwan	0223	---	---
U.S.A	0201	---	---	

MODEL	Spec code		Spec code (Detail)	
MFC-L8650CDW	CEE-General	0388	Bulgaria	0332
			Croatia	0381
			Czecho	0337
			Hungary	0338
			Poland	0339
			Romania	0333
			Slovakia	0330
			Slovenia	0382
			Others	0350
	China	0120	---	---
	France/Belgium/Netherlands	0355	Belgium	0308
			France	0305
			Netherlands	0309
	Germany	0303	---	---
	Italy/Iberia	0366	Italy	0316
			Portugal	0318
			Spain	0315
	Pan-Nordic	0357	Denmark	0313
			Finland	0312
			Norway	0307
Sweden			0326	
Others			0350	
Russia	0348	---	---	
Switzerland	0310	---	---	
UK	0304	---	---	
MFC-L8850CDW	Argentina	0436	---	---
	Asia	0440	---	---
	Australia/New Zealand	0456	Australia	0406
			New Zealand	0427
	Brazil	0442	---	---
	Canada	0402	---	---
	CEE-General	0488	Bulgaria	0432
			Croatia	0481
			Czecho	0437
			Hungary	0438
			Poland	0439
			Romania	0433
			Slovakia	0430
			Slovenia	0482
Others			0450	
Chile	0436	---	---	
France/Belgium/Netherlands	0455	Belgium	0408	
		France	0405	
		Netherlands	0409	
Germany	0403	---	---	

MODEL	Spec code		Spec code (Detail)	
MFC-L8850CDW	Gulf	0474	Gulf	0441
			South Africa	0424
			Turkey	0425
	Italy/Iberia	0466	Italy	0416
			Portugal	0418
			Spain	0415
	Italy-CONSIP	8416	---	---
	Pan-Nordic	0457	Denmark	0413
			Finland	0412
			Norway	0407
			Sweden	0426
			Others	0450
	Switzerland	0410	---	---
	Taiwan	0323	---	---
U.S.A	0401	---	---	
UK	0404	---	---	
MFC-L9550CDW	Asia	0540	---	---
	Australia/New Zealand	0556	Australia	0506
			New Zealand	0527
	Canada	0502	---	---
	CEE-General	0588	Bulgaria	0532
			Croatia	0581
			Czecho	0537
			Hungary	0538
			Poland	0539
			Romania	0533
			Slovakia	0530
			Slovenia	0582
			Others	0550
	France/Belgium/Netherlands	0555	Belgium	0508
			France	0505
			Netherlands	0509
	Germany	0503	---	---
	Italy/Iberia	0566	Italy	0516
			Portugal	0518
			Spain	0515
	Pan-Nordic	0557	Denmark	0513
			Finland	0512
Norway			0507	
Sweden			0526	
Others			0550	
Russia	0548	---	---	
Switzerland	0510	---	---	
U.S.A	0501	---	---	
UK	0504	---	---	

Note:

The above information is as of March 2016. Please confirm the latest firmware information which is available from your local Brother Customer Service.

1.3.31 Printout of maintenance information (Function code 77)

<Function>

This function is used to print the maintenance information, such as the remaining amount of consumables, number of replacements, and counter values.

<Operating procedure>

- (1) Press the 7 key twice in the initial state of the maintenance mode. Maintenance information starts to be printed.
- (2) When printing is finished, the machine returns to the initial state of the maintenance mode.

■ Maintenance information

```

MAINTENANCE Print Date:01/01/15
①MFC-L8650CDW ②Serial No.=000G01234567890 ③Model=8CE-513 ④Country=0304 ⑤SW CheckSum=8C/NG
⑥Main ROM: Ver.U U1310020858 ⑦Sub ROM: Ver.0.15 P1309301113 ⑧Boot ROM: B1309301052 ⑨Demo ROM: D-----
⑩HV ROM: 0.04BbC7 ⑪Panel Main ROM: T1309301200 ⑫Panel Boot ROM: 01309301400 ⑬Memory Version: a
⑭ROM ChkSum: 8E14 ⑮RTC Check: OK ⑯RTC BackUp: OK ⑰Before BackUp: 02:41 ⑱After BackUp: 03:17
⑲USB Prod.ID: 0312 ⑳RAM Size = 256Mbyte
⑳0000000 00000000 00000000 00000000
㉑00000000 00000000 00000000 00000000
㉒00000000 00000000 00000000 00000000
㉓0001 0001 0001 0001 0000 0000 0001
㉔00003480 00003480 00000000 00000000
㉕00000000 00000000 00000000 00000000
㉖00000000 00000000 00000000 00000000

Remaining life of :
㉗**Drum Unit: 24948 (100%) ㉘Belt Unit: 49868 (100%)
㉙Cyan(C): 95% ㉚PF Kit MP: 50000 (100%) ㉛Fuser Unit: 99954 (100%)
㉜Magenta(M): 95% ㉝PF Kit 1: 99958 (100%) ㉞Laser Unit: 99954 (100%)
㉟Yellow(Y): 95% ㊱PF Kit 2: 100000 (100%)
㊲Black(BK): 96%

<Device Status>
㊳Total Page Count: 46 ㊴Monochrome: 29 ㊵<Error History (last 10 errors)> Page (C) %
Color: 17 1: 6901:Self-Diagnostic 01/01/15 01:15 0 29 44
㊶Copy Count: 1 ㊷Monochrome: 0 2:
Color: 1 3:
㊸PC-Print Count: 19 ㊹Monochrome: 3 4:
Color: 16 5:
㊺List/FAX Count: 26 ㊻Monochrome: 26 6:
Color: 0 7:
8:
9:
10:
㊼***Average Coverage(Total)
Cyan(C): 5.32% Yellow(Y): 5.32%
Magenta(M): 5.27% Black(BK): 4.67%
㊽***Average Coverage(Current)* ㊾<Replace Count>
Cyan(C): 5.32% Yellow(Y): 5.32% Toner Cartridge
Magenta(M): 5.27% Black(BK): 4.67% Cyan(C): 0 (0)# 00/00/00 Belt Unit: 0
㊿***Average Coverage(Previous) Yellow(Y): 0 (0)# 00/00/00 Fuser Unit: 0
Cyan(C): 0.00% Black(BK): 0 (0)# 00/00/00 Laser Unit: 0
Magenta(M): 0.00% Yellow(Y): 0.00% Black(BK): 0 (0)# 00/00/00 PF Kit MP: 0
Drum Unit: 0 PF Kit 1: 0
Waste Toner: 0 PF Kit 2: 0

㋀<Drum Information (Page/Count)>
Drum Page Count: 52
Drum Count: 1148
㋁<Developing Roller Count (Current/Previous)>
(C): 1054/0 (Y): 1054/0
(M): 1054/0 (BK): 1869/0
㋂<Total Pages Printed>
MP Tray: 0 2-sided: 4
Tray 1: 42 Tray 2: 0
A4/Letter: 46 Envelope: 0
Legal/Folio: 0 A5: 0
B5/Executive: 0 Others: 0
Plain/Thin/Recycled: 46
Thick/Thicker/Bond: 0
Envelope/Env.Thick/Env.Thin: 0
Label: 0 Hagaki: 0
Glossy: 0
㋃Current Toner Previous Used Toner
Cyan(C): 17 Cyan(C): 0
Magenta(M): 17 Magenta(M): 0
Yellow(Y): 17 Yellow(Y): 0
Black(BK): 46 Black(BK): 0
㋄Waste Toner: 46
㋅Developing Roller Count (Current/Previous)
(C): 372/0 (Y): 372/0
(M): 372/0 (BK): 958/0
㋆<Total Paper Jams: 0>
Jam MP Tray: 0 Jam Inside: 0
Jam Tray 1: 0 Jam Rear: 0
Jam Tray 2: 0 Jam 2-sided: 0

* Remaining life will vary depending on the types of documents printed,
their coverage and device usage.
** Based on A4/Letter printing.
*** Calculated coverage.

```

Fig. 5-20

1	Model name	29	Remaining life of PF kit 1
2	Serial number	30	Remaining life of PF kit 2
3	Model code	31	Remaining life of belt unit
4	Spec code	32	Remaining life of fuser unit
5	Switch checksum (factory use)	33	Remaining life of laser unit
6	Main firmware version	34	Total printed page Color/Monochrome
7	Sub firmware version	35	Total copied pages Color/Monochrome
8	Boot firmware version	36	Total printed PC pages Color/Monochrome
9	Demo firmware version	37	Total printed list/fax pages Color/Monochrome
10	High-voltage firmware version	38	Accumulated average coverage
11	Panel firmware version	39	Average coverage (Current toner)
12	Panel boot firmware version	40	Average coverage (Previous used toner)
13	Memory version	41	Drum page count/Rotations of the drum
14	ROM CheckSum	42	Rotations of the developer roller (Current toner/Previous used toner)
15	RTC check		
16	RTC backup	43	Total printed pages per paper tray/ Paper size/Paper type
17	Time before RTC backup		
18	Time after RTC backup	44	Total printed pages by each toner cartridge (Current toner/Previous used toner)
19	USB ID code		
20	RAM size	45	Number of pages printed from the waste toner box
21	Function code 72 result/ Function code 55 result/ Wireless LAN country setting/ Wireless LAN output value/ WLAN Setup history/ Toner type CMYK (Current)/ Toner type CMYK (Previously used)	46	Rotations of the developer roller used in print- ing (Current toner/Previous used toner)
		47	Total number of paper jams/ Paper jams that have occurred in each section in the machine
22	Main PCB inspection log/ High-voltage inspection log/ Number of electric discharge errors/ Number of fuser unit errors/ The number of polygon motor lock errors/Process execution state	48	Machine error log/Total pages printed by the time of error occurrence/ Temperature and humidity at the time of error occurrence
		49	Number of times that consumables and period- ical replacement parts have been replaced
23	Next Power On State/ The number of times of the power supply waveform detection error/ Process execution state/ Process execution checksum	50	Total pages of scanning
		51	Communication error log
		52	Developing bias voltage value
24	Auto registration/ Developing bias voltage correction/ Gamma correction/ Auto registration (user)/ Developing bias voltage correction (user)/Gamma correction (user)/ Registration error/ Color calibration flag	53	Engine sensor log (Not necessary for maintenance work)
		54	Status log (Not necessary for maintenance work)
		55	Temperature and humidity under which Func- tion code 77 is executed/ Maximum and minimum temperature and humidity
25	Not necessary for maintenance work (ADF sensor log)	56	Total power distribution time
26	Estimated remaining life of toner	57	Number of times that the power is turned ON
27	Remaining life of drum unit	58	Date and time when the machine starts to be used/Initial set date and time of RTC
28	Remaining life of PF kit MP		

1.3.32 Operational check of fans (Function code 78)

<Function>

This function is used to check that each fan is operating normally. The rotation speed is changed among three settings: 100%, 50% and OFF

LCD	Parts name	Description
F	Fuser fan	Evacuate hot air of the fuser unit.
P	Power fan	Evacuate hot air of the low-voltage power supply PCB unit.
B	Blower	Intake air to prevent a dirt on the corona wire.

<Operating procedure>

- (1) Press the **7** and **8** keys in this order in the initial state of the maintenance mode. "F100 P100 B100" is displayed on the LCD, and all the fans operate at the rotating speed of 100%.
- (2) Press the **Mono Start** key. "F50 P 0 B 0" is displayed on the LCD, and the fuser fan only operates at the rotating speed of 50%.
- (3) Press the **Mono Start** key. "F0 P 0 B 0" is displayed on the LCD, and all the fans stop.
- (4) Press the **X** key to return the machine to the initial state of the maintenance mode.

■ Location of fans

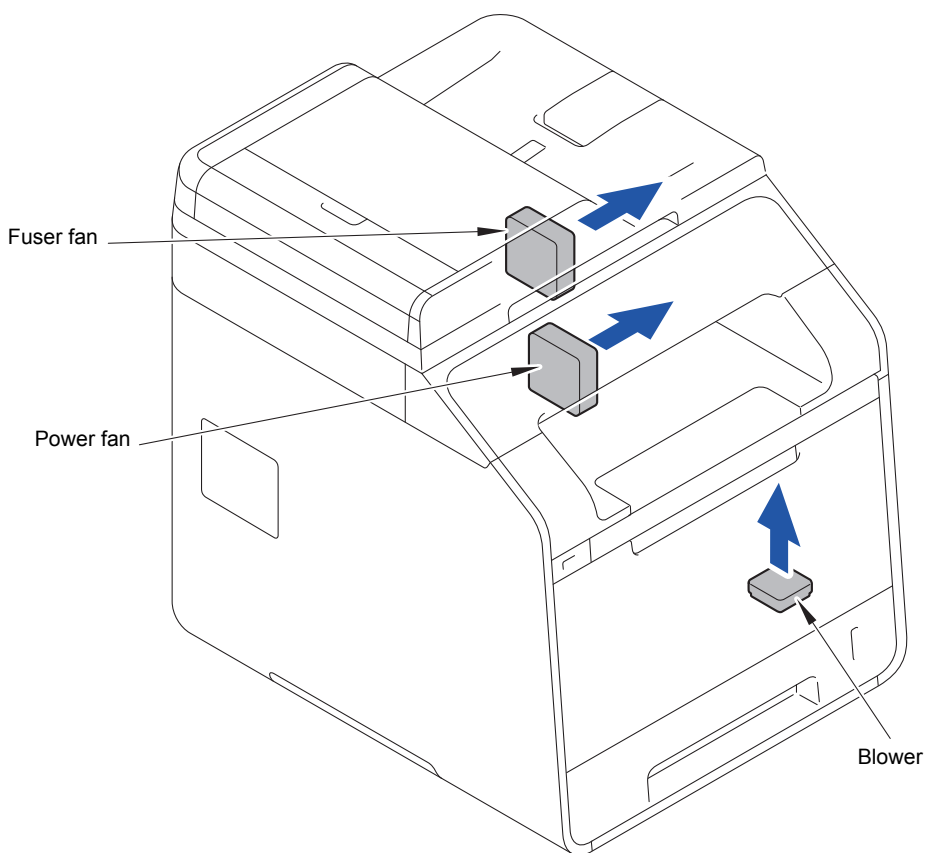

Fig. 5-21

1.3.33 Display of device log information (Function code 80)

<Function>

This function is used to display the log information on the LCD.

<Operating procedure>

- (1) Press the **8** and **0** keys in this order in the initial state of the maintenance mode.
"MACERR_01:****" is displayed on the LCD.
- (2) Each time you press the **Mono Start** key, a different item is displayed. Press the ◀ key to go back to the previous item.
- (3) Press the **X** key to return the machine to the initial state of the maintenance mode.

■ Maintenance information

LCD	Description
MACERR_#:0000	Machine error history (Past 10 error history) ^{*1}
USB:000G8J000166	Serial number ^{*2}
MAC:008077112233	MAC address
PCB:911309123456	Main PCB serial number
CTN_ERM:78%	Amount of remaining cyan toner estimated from coverage
CTN_RRM:67%	Amount of remaining cyan toner estimated from the number of developer rotations
MTN_ERM:78%	Amount of remaining magenta toner estimated from coverage
MTN_RRM:67%	Amount of remaining magenta toner estimated from the number of developer rotations
YTN_ERM:78%	Amount of remaining yellow toner estimated from coverage
YTN_RRM:67%	Amount of remaining yellow toner estimated from the number of developer rotations
KTN_ERM:87%	Amount of remaining black toner estimated from coverage
KTN_RRM:67%	Amount of remaining black toner estimated from the number of developer rotations
DRUM_PG:00000000	Number of pages printed on drum unit
PFMP_PG:00000000	Number of pages where PF kit MP has been used
PFK1_PG:00000000	Number of pages where PF kit 1 has been used
PFK2_PG:00000000	Number of pages where PF kit 2 has been used
FUSR_PG:00000000	Number of pages printed on fuser unit
LASR_PG:00000000	Number of pages printed on laser unit
BELT_PG:00000000	Number of pages printed on belt unit
TTL_PG:00000000	Total number of pages printed
TTL_CO:00000000	Total number of color pages printed
TTL_MO:00000000	Total number of monochrome pages printed
TTLCOPY:00000000	Total number of pages copied
CL_COPY:00000000	Total number of color pages copied
MN_COPY:00000000	Total number of monochrome pages copied
TTLPCPT:00000000	Total number of PC print pages
CL_PCPT:00000000	Total number of color PC print pages
MN_PCPT:00000000	Total number of monochrome PC print pages
TTLFAX:00000000	Total number of List/FAX outputs made ^{*3}

LCD	Description
MN_FAX:00000000	Total number of monochrome List/FAX printed pages *3
CCVRGUSI:4.32%	Average coverage of cyan toner cartridge in use
CCVRGACC:3.47%	Accumulated average coverage of cyan toner cartridge
MCVRGUSI:4.32%	Average coverage of magenta toner cartridge in use
MCVRGACC:3.47%	Accumulated average coverage of magenta toner cartridge
YCVRGUSI:4.32%	Average coverage of yellow toner cartridge in use
YCVRGACC:3.47%	Accumulated average coverage of yellow toner cartridge
KCVRGUSI:4.32%	Average coverage of black toner cartridge in use
KCVRGACC:3.47%	Accumulated average coverage of black toner cartridge
DRUM:00000000	Number of drum rotations
CTN_RND: 00000000	Number of cyan developer roller rotations
MTN_RND: 00000000	Number of magenta developer roller rotations
YTN_RND: 00000000	Number of yellow developer roller rotations
KTN_RND: 00000000	Number of black developer roller rotations
MP_PG:00000000	Number of pages picked up from the MP tray
TR1_PG:00000000	Number of pages picked up from the paper tray 1
DX_PG:00000000	Number of pages picked up from the duplex tray
TR2_PG:00000000	Number of pages picked up from the T2 paper tray unit
A4+LTR:00000000	Total number of paper input of A4 and Letter size paper
LG+FOL:00000000	Total number of paper input of Legal and Folio size paper
B5+EXE:00000000	Total number of paper input of B5 and Executive size paper
ENVLOP:00000000	Number of paper input of Envelope size
A5 :00000000	Number of paper input of A5 size (including A5 Long Edge) paper
OTHER :00000000	Number of paper input of other-size paper
PLTNRE:00000000	Total of pages printed on plain, thin, and recycled paper
TKTRBD:00000000	Total of pages printed on thick, thicker paper and bond paper
ENVTYP:00000000	Total of pages printed on envelopes, envelopes (thick), and envelopes (thin)
LABEL:00000000	Number of pages printed on label
HAGAKI:00000000	Number of pages printed on post card
GLOSSY:00000000	Number of pages printed on glossy paper
TTL_JAM:00000000	Total of jammed sheets
MP_JAM:00000	Number of sheets jammed in the MP tray
TR1_JAM:00000000	Number of sheets jammed in the Paper tray 1
IN_JAM:00000000	Number of sheets jammed inside the center of the machine
RE_JAM:00000000	Number of sheets jammed near the paper eject ASSY back cover
DX_JAM:00000000	Number of sheets jammed in the duplex tray
TR2_JAM:00000	Number of sheets jammed in the T2 paper tray unit
POWER:00000375	Total hours of current conduction (Unit: H)
PWRCNT:00000001	Number of times that the power is turned ON
CTN_CH:0000	Number of times that the cyan toner cartridge has been replaced *4
MTN_CH:0000	Number of times that the magenta toner cartridge has been replaced *4

LCD	Description
YTN_CH:0000	Number of times that the yellow toner cartridge has been replaced ^{*4}
KTN_CH:0000	Number of times that the black toner cartridge has been replaced ^{*4}
DRUM_CH:0000	Number of times that the drum unit has been replaced ^{*4}
WTNR_CH:0000	Number of times that the waste toner box has been replaced ^{*4}
BELT_CH:0000	Number of times that the belt unit has been replaced ^{*4}
FUSR_CH:0000	Number of times that the fuser unit has been replaced ^{*4}
LASR_CH:0000	Number of times that the laser unit has been replaced ^{*4}
PFMP_CH:000	Number of times that the PF kit MP has been replaced ^{*4}
PFK1_CH:0000	Number of times that the PF kit 1 has been replaced ^{*4}
PFK2_CH:000	Number of times that the PF kit 2 has been replaced ^{*4}
CTN_PG1:00000000	Number of pages printed from the currently installed cyan toner cartridge
CTN_PG2:00000000	Number of pages printed from the previous installed cyan toner cartridge
MTN_PG1:00000000	Number of pages printed from the currently installed magenta toner cartridge
MTN_PG2:00000000	Number of pages printed from the previous installed magenta toner cartridge
YTN_PG1:00000000	Number of pages printed from the currently installed yellow toner cartridge
YTN_PG2:00000000	Number of pages printed from the previous installed yellow toner cartridge
KTN_PG1:00000000	Number of pages printed from the currently installed black toner cartridge
KTN_PG2:00000000	Number of pages printed from the previous installed black toner cartridge
WTNR_PG:00000000	Number of pages printed from the waste toner box
ADSX_PG:00000000	Number of sheets scanned in one-sided scanning with the ADF
ADDX_PG:00000000	Number of sheets scanned in two-sided scanning with the ADF (Duplex scanning model only)
FB_PG:000000	Number of sheets scanned with the FB
ADSX_JAM:000000	Number of documents jammed at one-sided scanning with the ADF
ADDX_JAM:000000	Number of documents jammed at two-sided scanning with the ADF (Duplex scanning model only)
COMERR#:00000000	Communication error history (Past 3 error history) ^{*5} (Models with Fax function only)
CDEV_BIAS:400V	Cyan developing bias voltage
MDEV_BIAS:400V	Magenta developing bias voltage
YDEV_BIAS:400V	Yellow developing bias voltage
KDEV_BIAS:400V	Black developing bias voltage
ENGERR##:000000	Engine error history (Past 10 error history) ^{*6}
HODN_ER:0000	Number of times that the electric discharge error occurs
FUSR_ER:0000	Number of times that the fuser unit error occurs
MTLK_ER:0000	Number of times that the polygon motor lock error of the laser unit occurs
BCLN:00000000	Number of belt cleaner roller rotations
DEVSTATUS_###:00	Log for design analysis ^{*7}

*1 01 to 10 are entered in ## in chronological order. When you press the **SET** key as the machine error history is displayed, “PGCNT:00000000” (the page counter when the error occurred) is displayed on the LCD. When you press the **OK** key or the **SET** key once more, “TMP:000 HUM:000” (the temperature and humidity when the error occurred) is displayed on the LCD.

*2 The serial number can be changed according to the steps below.

- 1) Press the **9**, **4**, **7**, and **5** keys in this order while the serial number is displayed. The first digit of the serial number displayed on the LCD starts blinking, and the machine enters the edit mode.
- 2) Enter the number of the first digit of the serial number using the ten-key pad. The blinking cursor moves to the second digit. Similarly, repeat the entering of the serial numbers of the 2nd to the last 15th digit.

<How to enter alphabets>

To enter alphabets other than A, B, C, D, E, and F, keep pressing a corresponding key in the ten-key pad based on the table given below until the alphabet you want to enter is displayed.

Ten-key pad	Corresponding alphabet
4	4→G→H→I
5	5→J→K→L
6	6→M→N→O
7	7→P→Q→R→S
8	8→T→U→V
9	9→W→X→Y→Z

- 3) When you press the **SET** key, the serial number is written and the machine returns to the initial state of the maintenance mode.

*3 For the models without FAX function, “TLLIST:00000000” is displayed on the LCD, and the number of the List printed pages is displayed.

*4 If you press the **SET** key with the replacement count of a consumable part is displayed, “DATE_XX:000000” (XX: indicates a relevant consumable part) and the date of replacement are displayed on the LCD. (The date is not displayed on the models without RTC.)

*5 If you press the **SET** key with a communication error is displayed, “DATE:0000000000” and the date of replacement are displayed on the LCD. (The date is not displayed on the models without RTC.)

*6 01 to 10 are entered in ## in chronological order. When you press the **SET** key as the engine error history is displayed, “TM:00000 BT:000” (TM: elapsed time (minute) from the previous error and BT: the number of times when the power is ON/OFF) is displayed on the LCD.

*7 01 to 10 are entered in ## in chronological order. When you press the **SET** key as the log for design analysis is displayed, “PGCNT:00000000” (the page count when the error occurred) is displayed on the LCD.

1.3.34 Display of device error codes (Function code 82)

<Function>

This function is used to display the latest error code on the LCD.

<Operating procedure>

- (1) Press the **8** and **2** keys in this order in the initial state of the maintenance mode.
“MACHINE ERR XXXX” is displayed on the LCD.
- (2) Press the **X** key to return the machine to the initial state of the maintenance mode.

1.3.35 Developing bias voltage correction (Function code 83)

<Function>

This function performs developing bias voltage correction to fix the density of each color toner when printed color is not correct.

Note:

Before this function is performed, there is a need that the “1.3.28 Sensitivity adjustment of density sensor (Function code 72)” in this chapter has been done more than once. When performing this maintenance mode 83 after replacing the main PCB ASSY, make sure to perform the “1.3.28 Sensitivity adjustment of density sensor (Function code 72)” first.

<Operating procedure>

- (1) Press the **8** and **3** keys in this order in the initial state of the maintenance mode.
The machine displays “PLS WAIT 83” on the LCD and starts the developing bias voltage correction.
- (2) When developing bias voltage correction is completed, “MODE KYMC ****” is displayed on the LCD. When you press the **Mono Start** key, the machine returns to the initial state of the maintenance mode.
(* represents any number from 0 to 3.)

Note:

If developing bias voltage correction fails, “ERROR 83” is displayed on the LCD. Display the error message by pressing the ▼ key, and take the following measure that corresponds to the error message.

Error message	Measure
FAILED DEVBIAS	Remove the error factors with the following operations and press the Mono Start key to clear the error. <ul style="list-style-type: none">- Re-insert the toner cartridge in the correct position.- Replace the toner cartridge.- Replace the drum unit.- Replace the waste toner box.- Replace the belt unit.- Replace the registration mark sensor unit.
TONER EMPTY # *	Replace the empty toner cartridge and press the Mono Start key to clear the error. After the sensitivity adjustment of the density sensor (Function code 72) is performed, the developing bias voltage value is compensated again.
Cover is Open	Close the front cover.
Replace Toner	Replace the black toner cartridge and press the Mono Start key to clear the error. After the sensitivity adjustment of the density sensor (Function code 72) is performed, the developing bias voltage value is compensated again.

* # indicates the toner color (Y, M, or C) of which cartridge became empty.

1.3.36 Sending of communication log information to telephone line (Function code 87)

<Function>

This function is used to send the error list to service personnel at a remote service station when a fax communication problem has occurred in the user's machine. Receiving the error list allows the service personnel to analyze the problem current in the user's machine.

<Operating procedure>

- Service side

(1) Make a call from the machine on the service side to the user's machine.

- User side

(2) Hold down the **Home** key in the ready state until the display on the LCD changes.

Memo:

If you cannot find the **Home** key, press the **Toner** key, and the **Home** key lights up.



(3) Hold down the blank box at the bottom on the LCD until the display on the LCD changes.

(4) Press the *, **0**, #, **8** and **7** keys in this order. "SENDING P.01" is displayed on the LCD, and the error list is sent. When the machine finishes sending the error list, it returns to the ready state.

- Service side

(5) When the user side starts sending the error list, press the **Start** key. "Send or Receive? / 1.Send 2.Receive" is displayed on the LCD.

(6) Press the **2** key. The machine starts receiving the error list.

1.3.37 Reset counters for parts (Function code 88)

<Function>

After replacing a fuser unit, PF kit 1, 2, MP, laser unit, or low-voltage power supply PCB unit, perform this function to increase the replacement count by one and reset the count to clear the "Replace ***" warning.

<Operating procedure>

- (1) Press the **8** key twice in the initial state of the maintenance mode. "Reset-Laser Unit" is displayed on the LCD.
- (2) Press the **▲** or **▼** key to display the part of which counter you want to reset and press the **Mono Start** key.
- (3) Then "*****OK?" is displayed on the LCD. When you press the **Mono Start** key, the counter of the selected part is reset, and the machine returns to step (2) again. (***** represents the selected part name.)
- (4) Press the **X** key to return the machine to the initial state of the maintenance mode.

The parts that can be selected are shown in the table below.

LCD	Part name
Reset-Laser Unit	Laser unit
Reset-Fuser Unit	Fuser unit
Reset-PF Kit T1	PF kit 1
Reset-PF Kit T2	PF kit 2
Reset-PF Kit MP	PF kit MP
Reset-LVPS	Low-voltage power supply PCB unit

1.3.38 Exit from the maintenance mode (Function code 99)

<Function>

This function is used to exit from the maintenance mode, restart the machine, and return to the ready state. If the error related to the fuser unit occurs, the error is cleared.

<Operating procedure>

- (1) Press the **9** key twice in the initial state of the maintenance mode. The machine exits from the maintenance mode and return to the ready state.

2. OTHER SERVICE FUNCTIONS

2.1 Printing of Communication List

<Function>

This function is used to print Communication List.

<Operating procedure>

- (1) Hold down the **Home** key for about 5 seconds while the machine is in the ready state. The serial number screen is displayed on the LCD.

Memo:

If you cannot find the **Home** key, press the **Toner** key, and the **Home** key lights up.



- (2) Hold down the blank space at the bottom of the LCD for about 2 seconds. The screen containing the ten-key pad and Start key is displayed on the LCD.
- (3) Press the **#**, **1**, **0**, **4**, **1**, and **4** in this order. Then, Communication List is printed.
- (4) Press the **X** key and the machine returns to the ready state.

2.2 Drum Cleaning

<Function>

This function is to attach a special cleaning sheet on the drum unit and perform the cleaning of the drum.

<Operating procedure>

- (1) Press the  (Settings) key in the ready state.
- (2) Press the **All Settings** key.
- (3) Press the ▲ or ▼ key to display “Machine Info.” and then press the **Machine Info.** key.
- (4) Press the ▲ or ▼ key to display “Parts Life” and then press the **Parts Life** key.
- (5) Hold down any of the keys in the ten-key pad, which is OFF, for approximately 0.5 second.
Then, the ten-key pad is displayed.
- (6) Hold down the * key for 5 seconds or more. “Attach the cleaning sheet. Please refer to the included instructions.” is displayed on the LCD.
- (7) Open the front cover, take out the drum unit, and attach the cleaning sheet on the drum unit. (For the method of attaching the cleaning sheet, refer to the insertion of the cleaning sheet.)
- (8) Put the drum unit back in the machine and close the front cover. “Please wait” is displayed on the LCD, and then drum cleaning starts.
- (9) When drum cleaning is completed, “Drum Cleaning completed. Remove the cleaning sheet.” is displayed on the LCD. Then, open the front cover, take out the drum unit, and remove the cleaning sheet from the drum unit.
- (10) Put the drum unit back in the machine and close the front cover. Then the machine returns to the ready state.

2.3 Counter Reset of Consumable Parts (Drum unit/Belt unit)

<Function>

After replacing a drum unit or belt unit, perform this function to increase the replacement count by one and reset the count to clear the "Replace ***" warning.

<Operating procedure>

- (1) Press the  (Settings) key in the ready state.
- (2) Press the **All Settings** key.
- (3) Press the ▲ or ▼ key to display "Machine Info." and then press the **Machine Info.** key.
- (4) Press the ▲ or ▼ key to display "Parts Life" and then press the **Parts Life** key.
- (5) Hold down the # key for 5 seconds or more. "Reset Menu" is displayed on the LCD.
- (6) "Drum" and "Belt Unit" are displayed on the LCD. Press the key of the part you want to reset. "Reset *****?" is displayed on the LCD. (***** represents the selected part name.)
- (7) Press the **Yes** key. "Accepted" is displayed on the LCD and the counter of the selected part is reset.

The consumable parts that can be selected are shown in the table below.

LCD	Part name
Drum	Drum unit
Belt Unit	Belt unit

CHAPTER 6 WIRING DIAGRAM

1. WIRING DIAGRAM

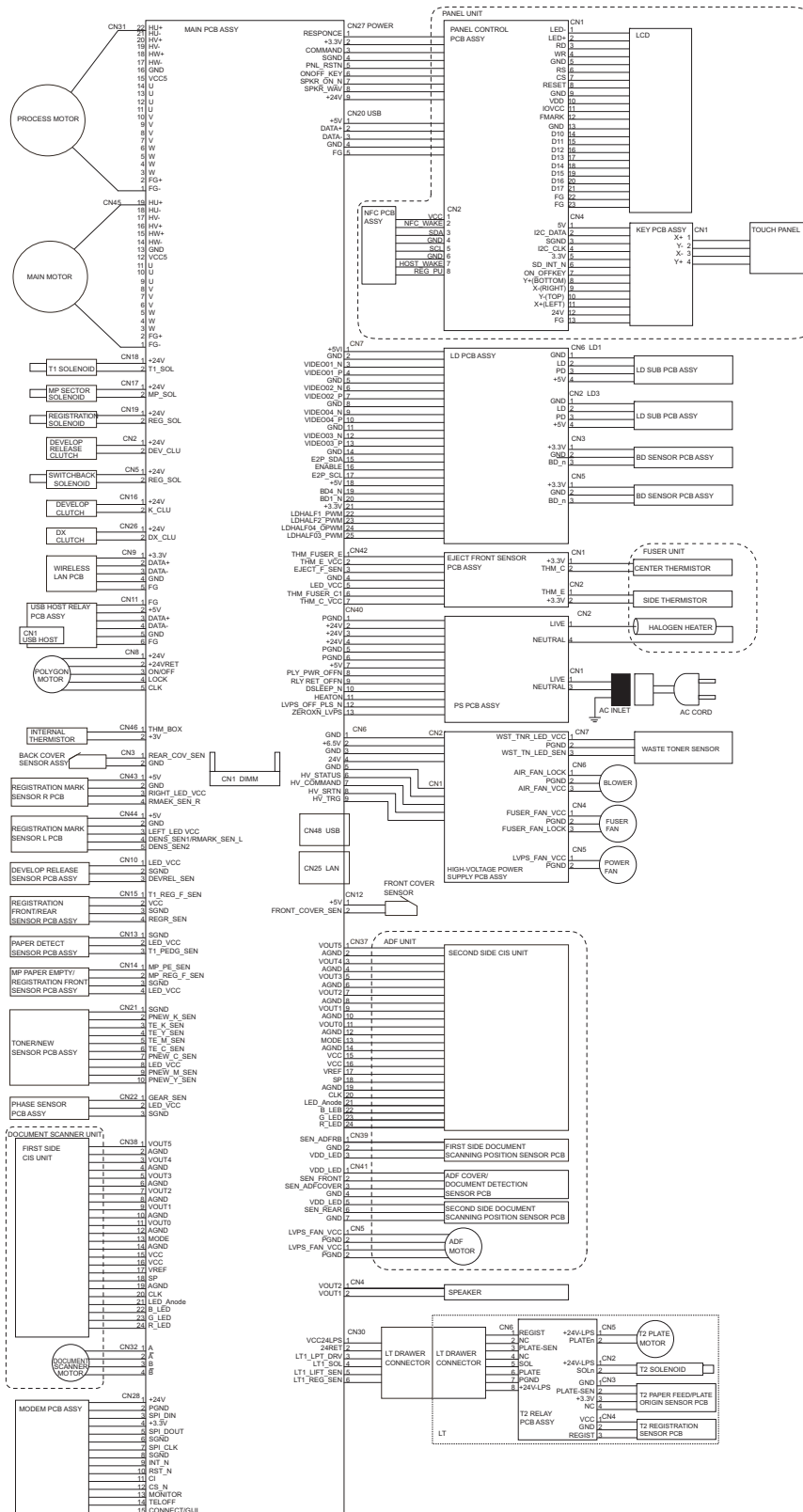

CHAPTER 7 PERIODICAL MAINTENANCE

1. SAFETY PRECAUTIONS

To avoid creating secondary problems by mishandling, follow the warnings and precautions below during maintenance work.

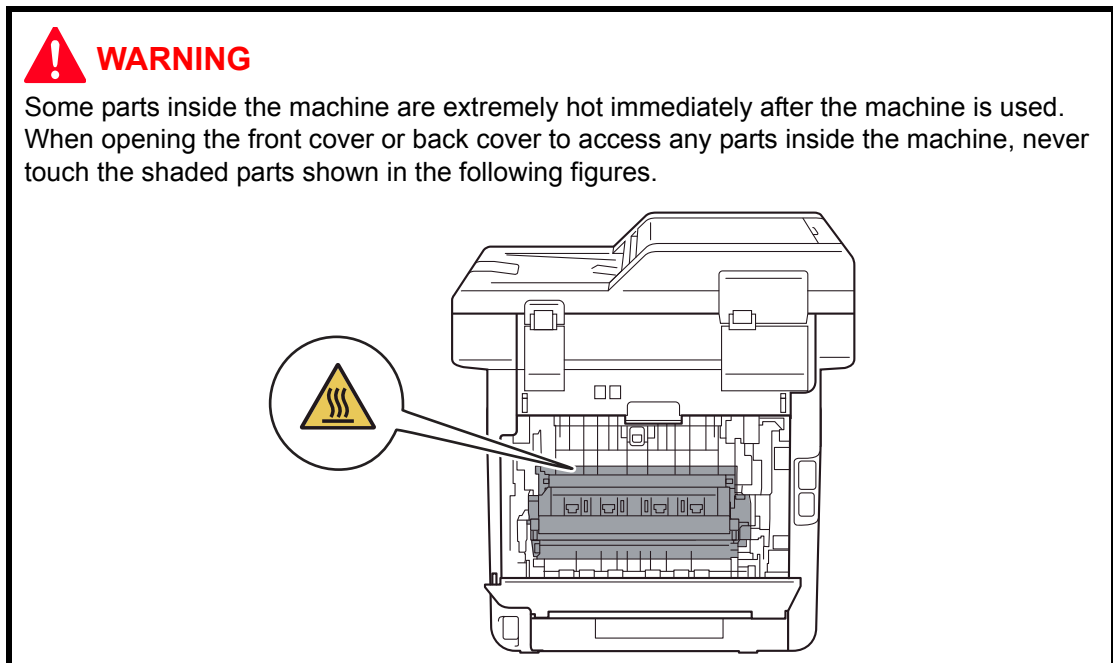

Note:

- Be careful not to lose screws, washers, or other parts removed.
- Be sure to apply grease to the gears and applicable positions specified in [Chapter 3](#).
- When using soldering irons or other heat-generating tools, take care not to accidentally damage parts such as wires, PCBs and covers.
- Static electricity charged in your body may damage electronic parts. When transporting PCBs, be sure to wrap them in conductive sheets.
- When replacing the PCB and all the other related parts, put on a grounding wrist band and perform the job on a static mat. Also take care not to touch the conductor sections on the flat cables or on the wire harness.
- After disconnecting flat cables, check that each cable is not damaged at its end or short-circuited.
- When connecting flat cables, do not insert them at an angle. After insertion, check that the cables are not at an angle.
- When connecting or disconnecting harnesses, hold the connector body, not the cables. If the connector is locked, release it first.
- After a repair, check not only the repaired portion but also handling of harnesses. Also check that other related portions are functioning properly before operational checks.
- After an assembly, recommend the operation of “dielectric strength voltage check” and “continuity check”.
- There must be no damage in the insulation sheet.
- After a repair, update the firmware to the latest version.

2. PERIODICAL REPLACEMENT PARTS

2.1 Procedures to Replace Periodical Replacement Parts

■ Preparation

Prior to proceeding with the disassembly procedure,

- (1) Unplug
 - the AC cord,
 - the telephone line,
 - the USB flash memory,
 - the USB cable, if connected, and
 - the LAN cable, if connected.
- (2) Remove the Paper tray.

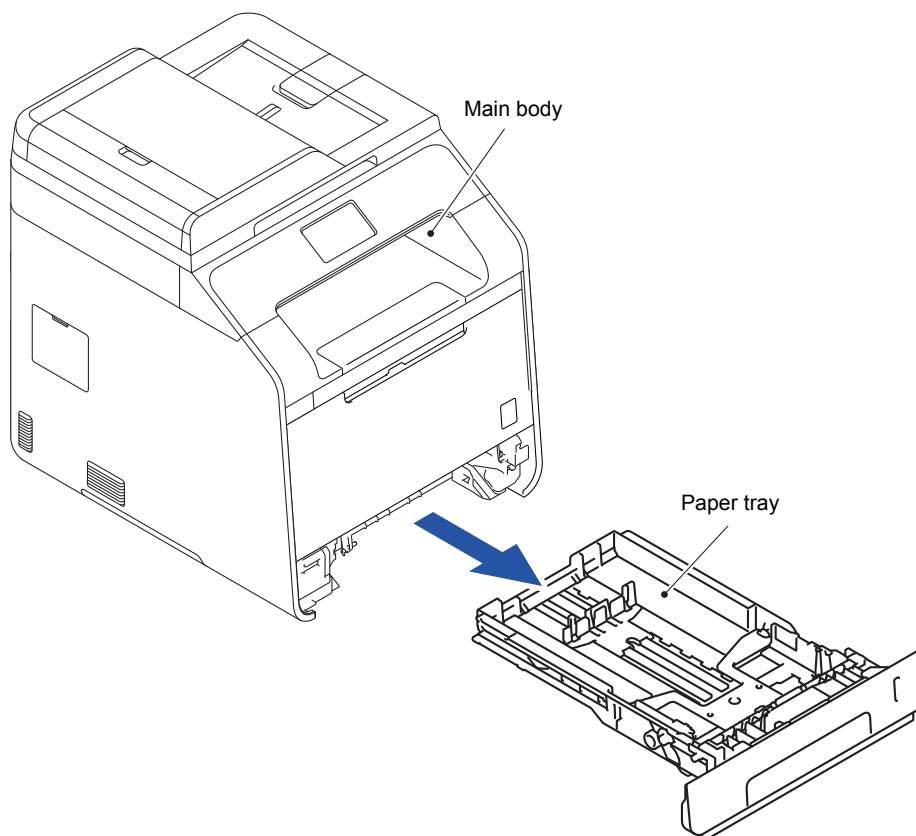

2.1.1 Fuser unit

(1) Open the Back cover.

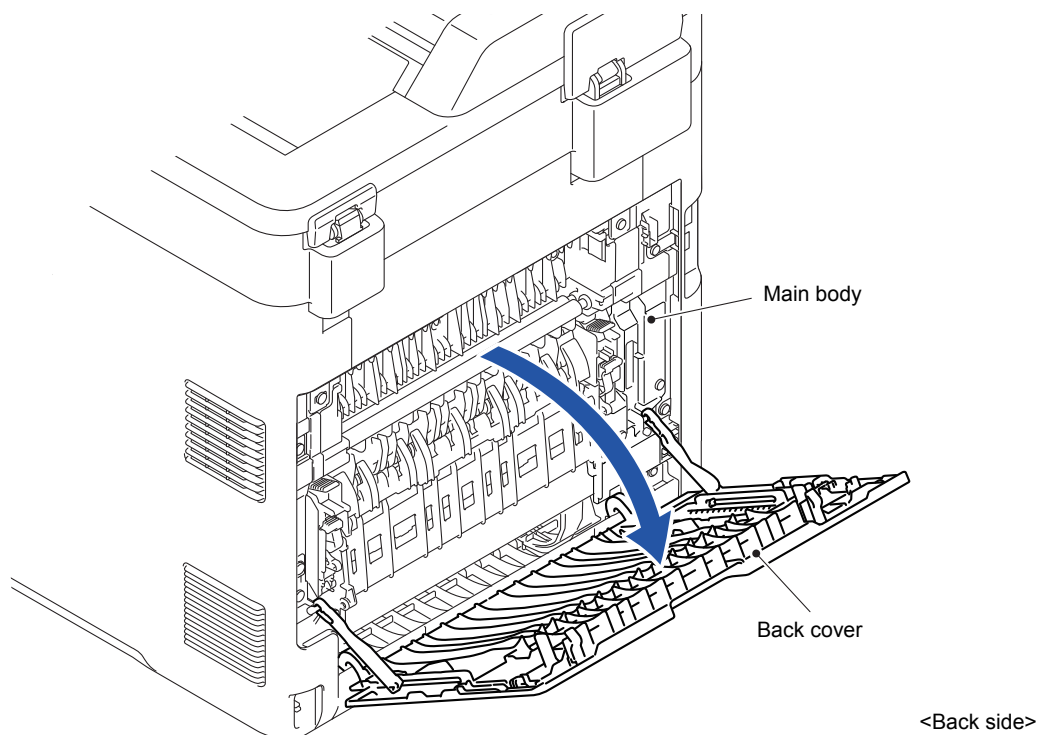

Fig. 7-1

(2) Remove the Back cover stopper arm L/R from the Main body.

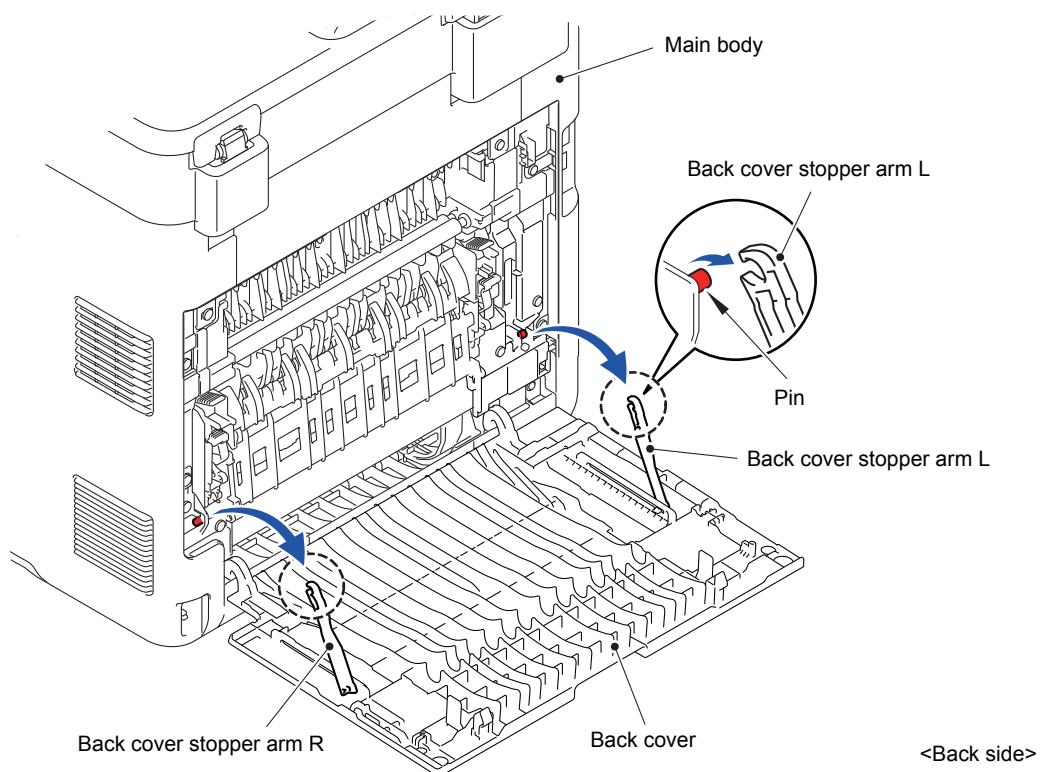

Fig. 7-2

(3) Remove the Shaft of the Back cover from the Bush on the right side of the Main body.

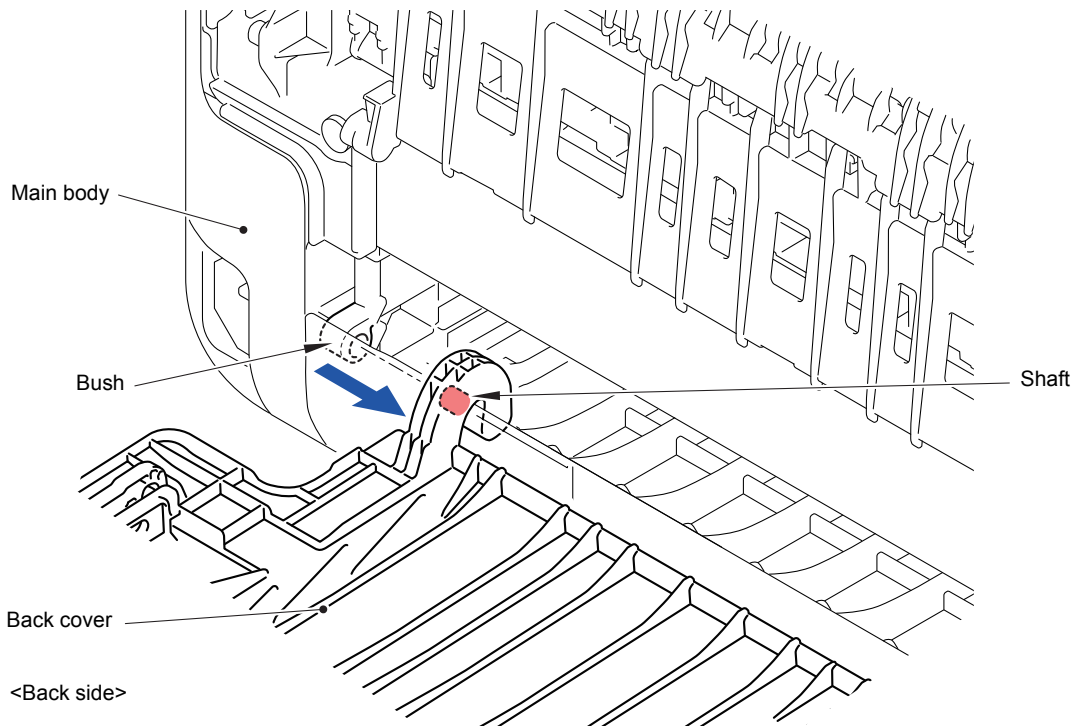

Fig. 7-3

(4) Remove the Back cover.

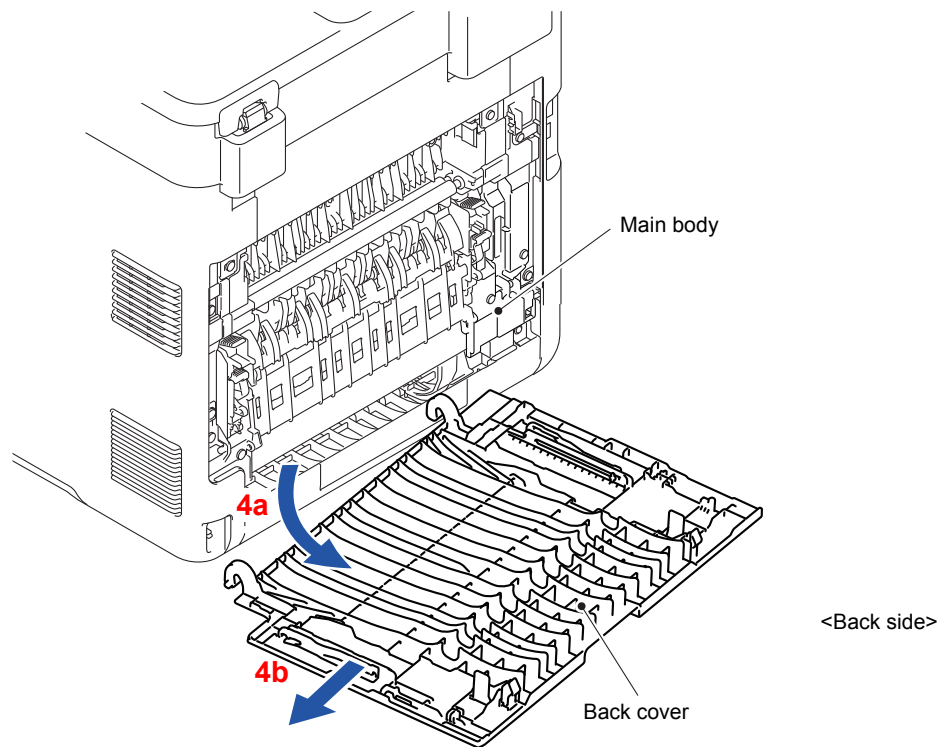

Fig. 7-4

- (5) Open the Back flapper holder.
Release the two Pins and remove the Back flapper holder from the Main body.

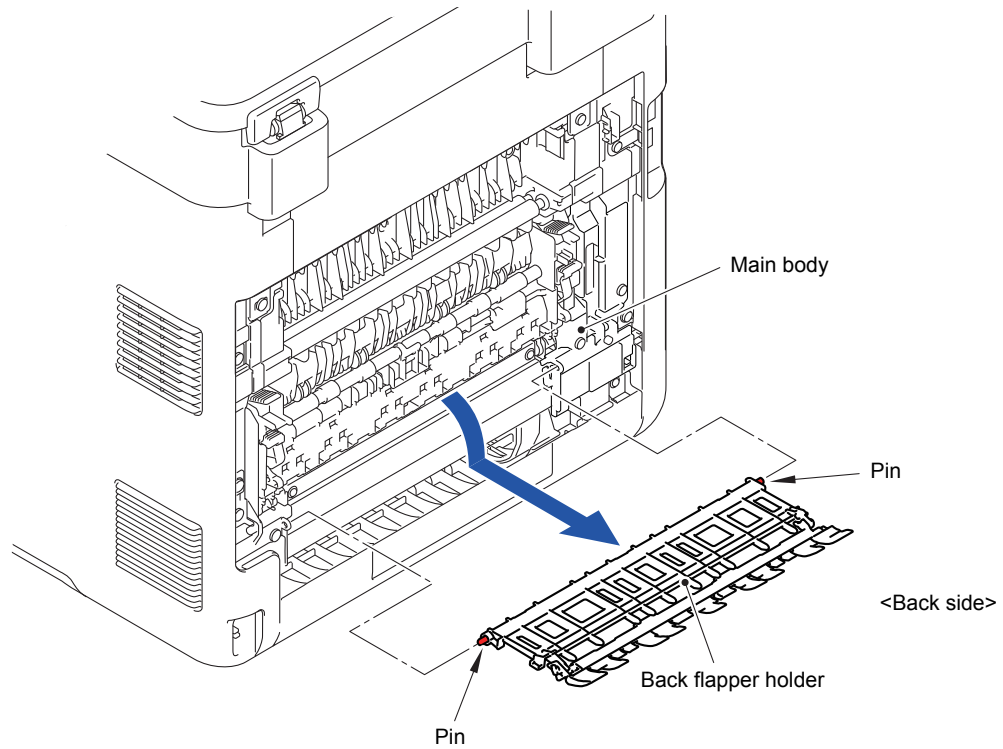

Fig. 7-5

- (6) Remove the two Taptite bind B M4x12 screws from the Fuser cover L.
- (7) Remove the one Hook and one Pin and remove the Fuser cover L from the Main body.

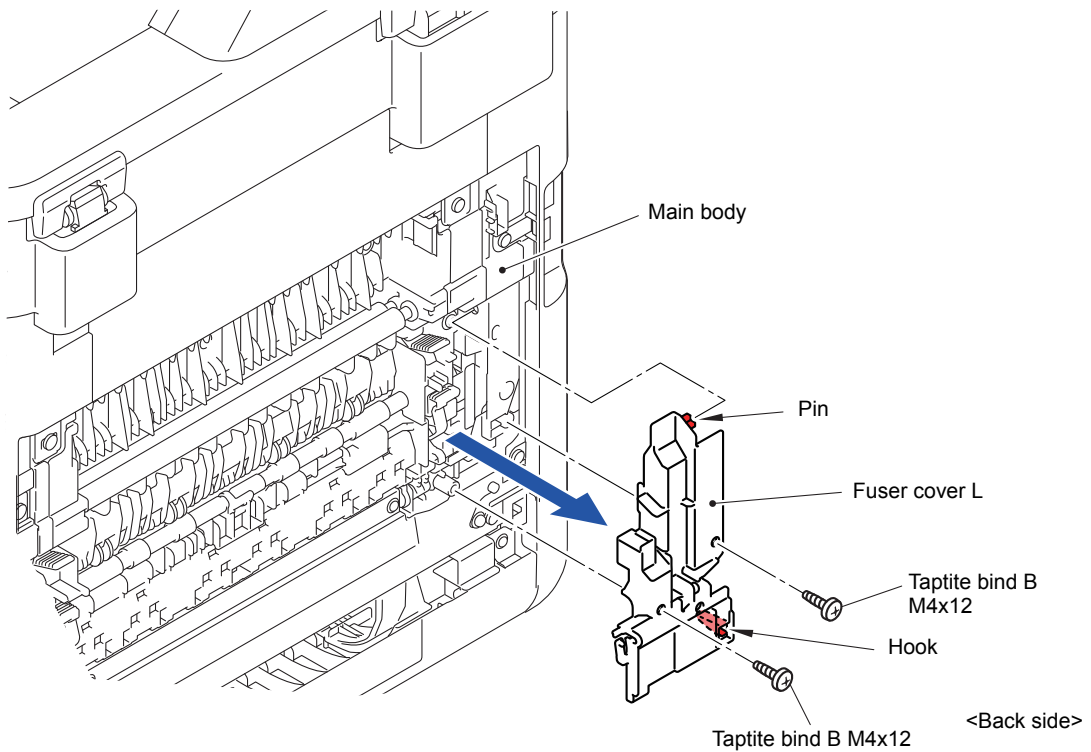

Fig. 7-6

(8) Release the lock of the Fuser cover lock lever L/R to open the Fuser cover ASSY.

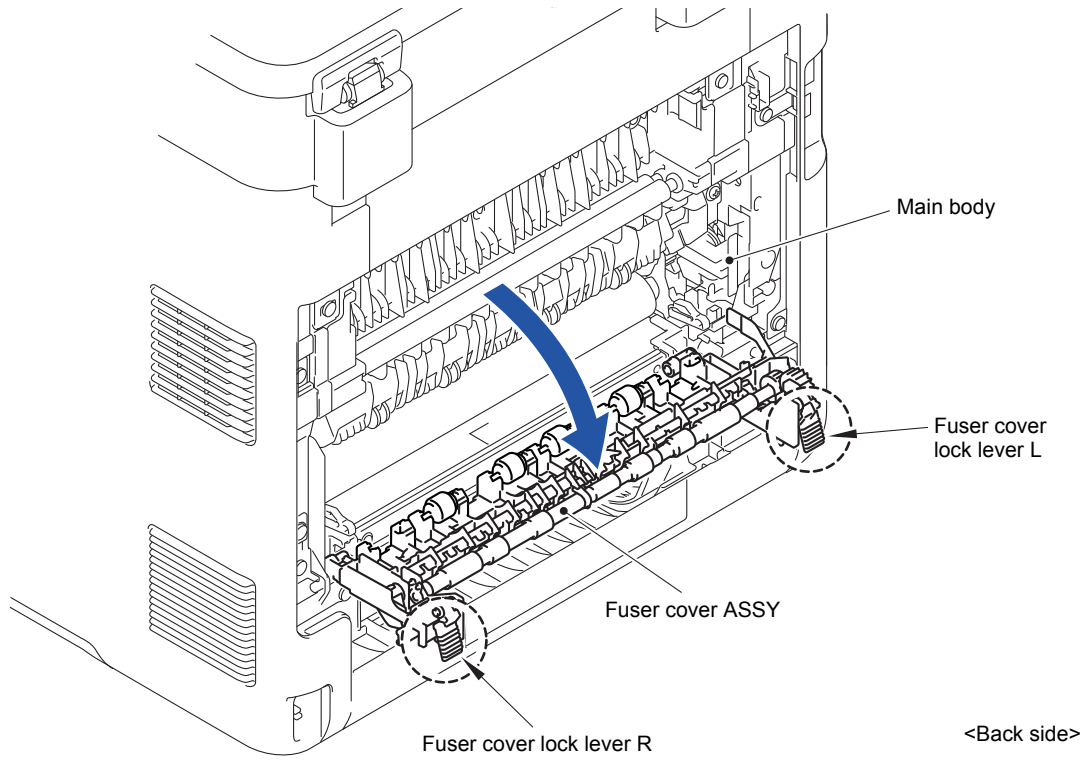

Fig. 7-7

(9) Slide the Fuser cover ASSY in the direction of the arrow 9a and remove it to the front.

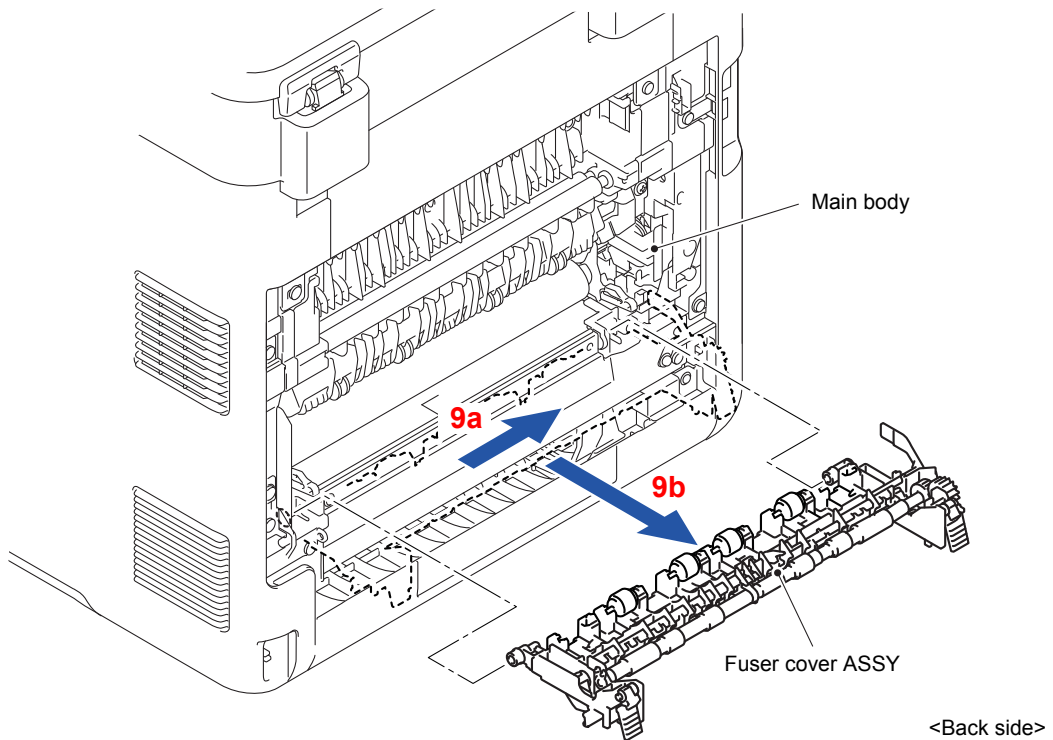

Fig. 7-8

(10) Remove the Cleaner roller spring from the Hook of the Fuser cover ASSY.

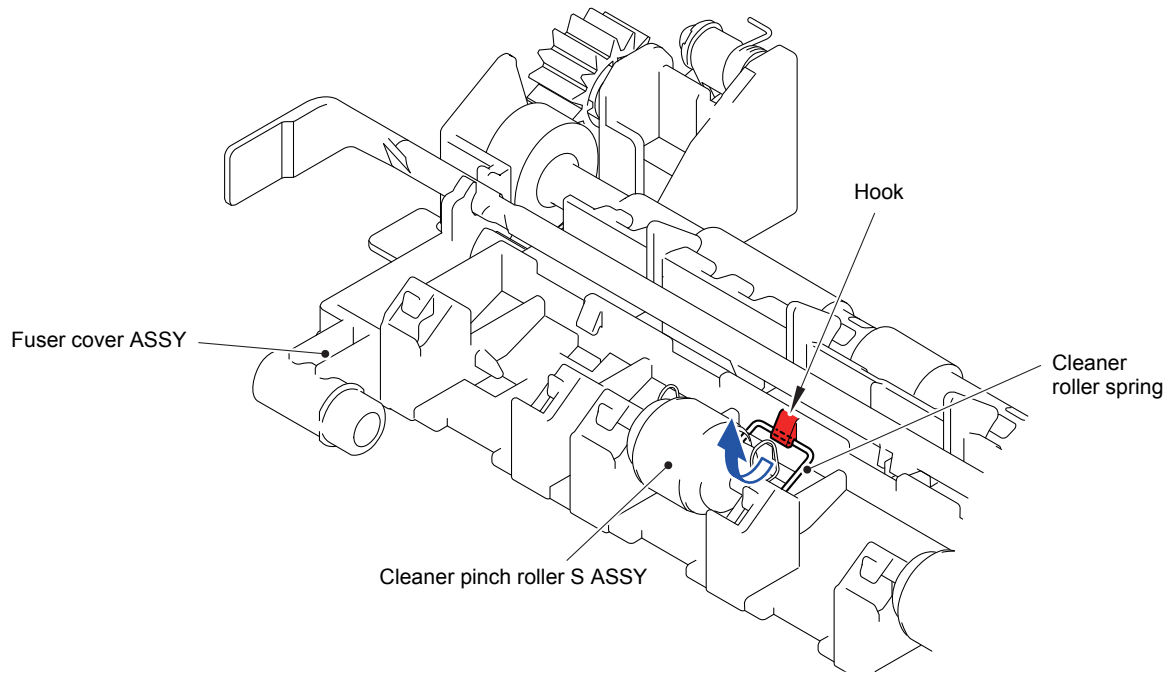

Fig. 7-9

(11) Remove the Cleaner roller spring from the two Pins of the Fuser cover ASSY.
Remove the Cleaner pinch roller S ASSY and Cleaner roller spring from the Fuser cover ASSY.

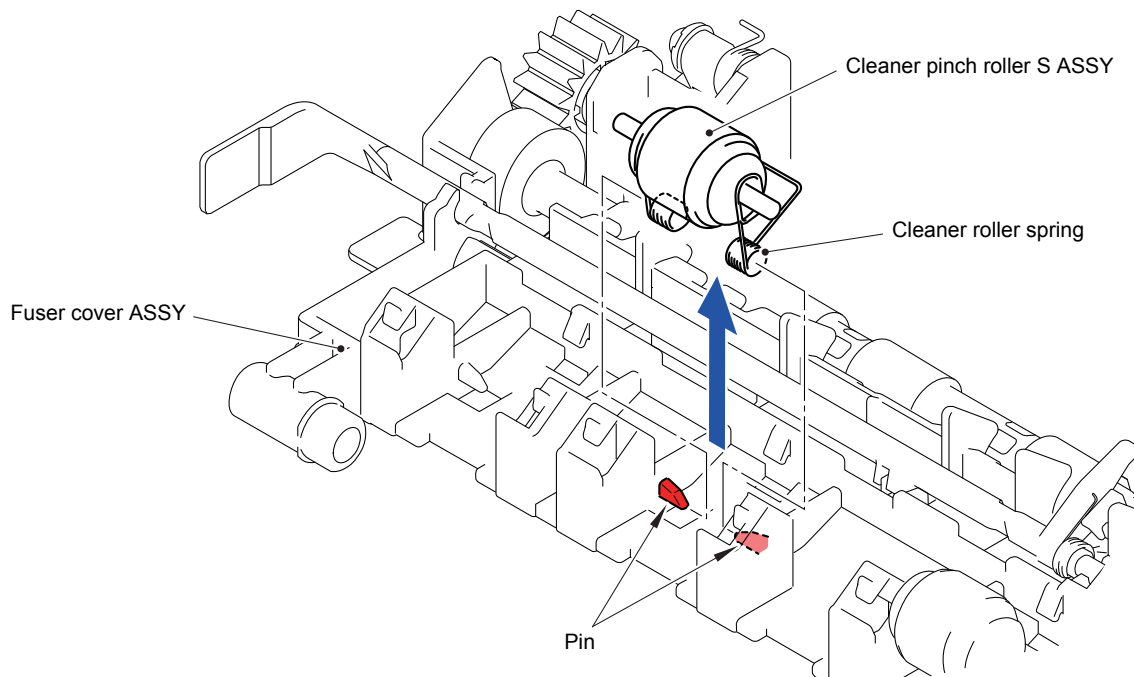

Fig. 7-10

(12) Remove the Cleaner pinch roller S ASSY from the Cleaner roller spring.

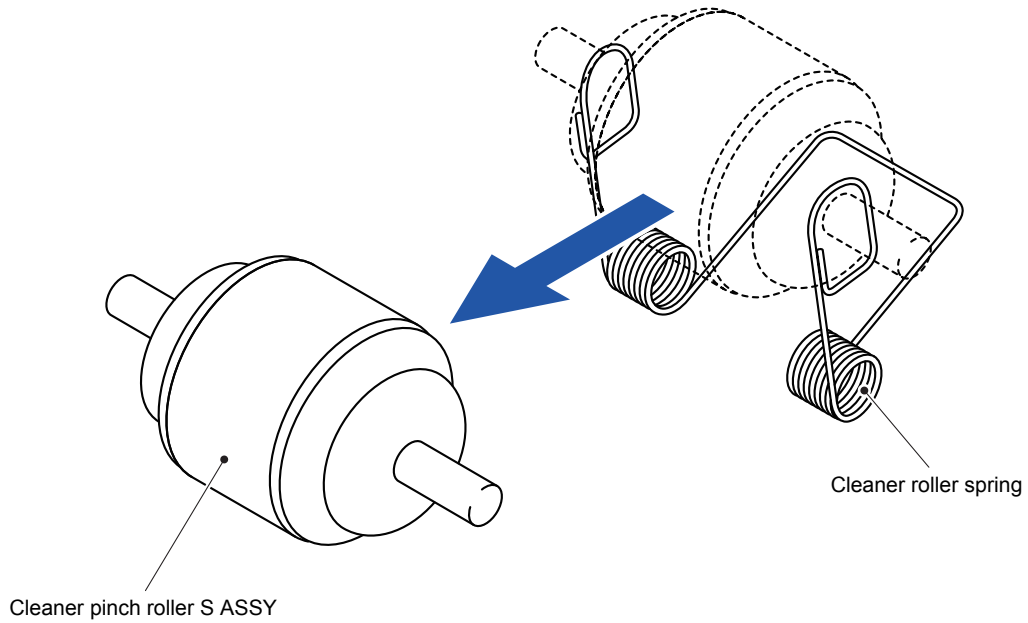

Fig. 7-11

(13) Remove the other three Cleaner pinch roller S ASSYs in the same way.

(14) Remove the two Taptite bind B M4x12 screws from the Fuser cover R.

(15) Release the two Hooks and remove the Fuser cover R from the Main body.

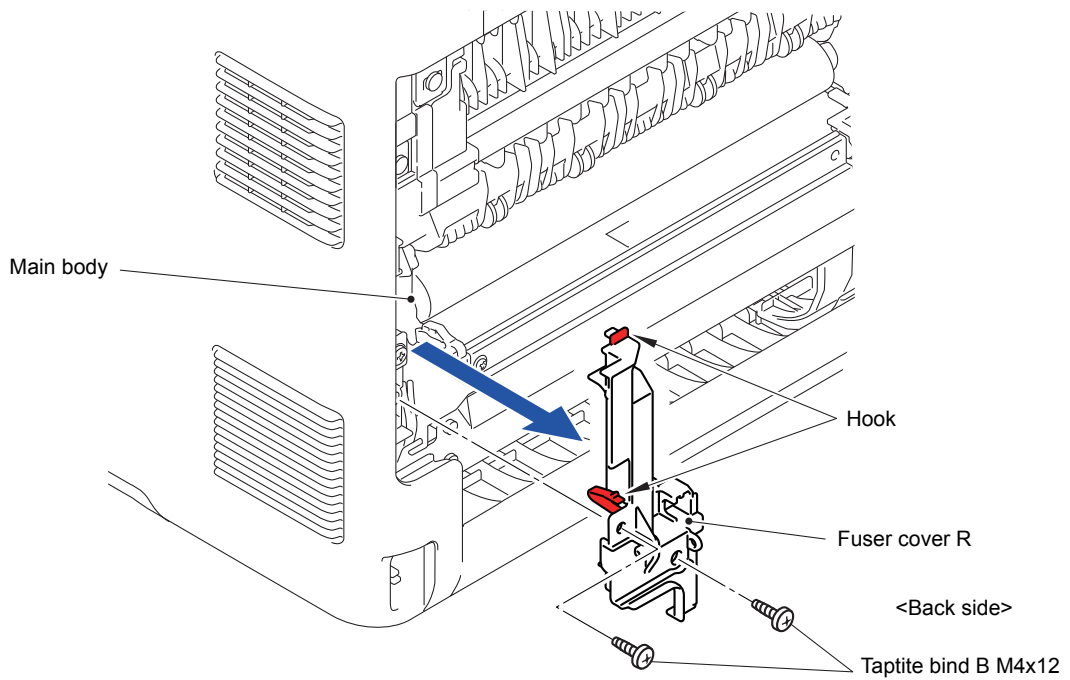

Fig. 7-12

(16) Disconnect the two Connectors (CN1 and CN2) from the Eject sensor PCB ASSY.

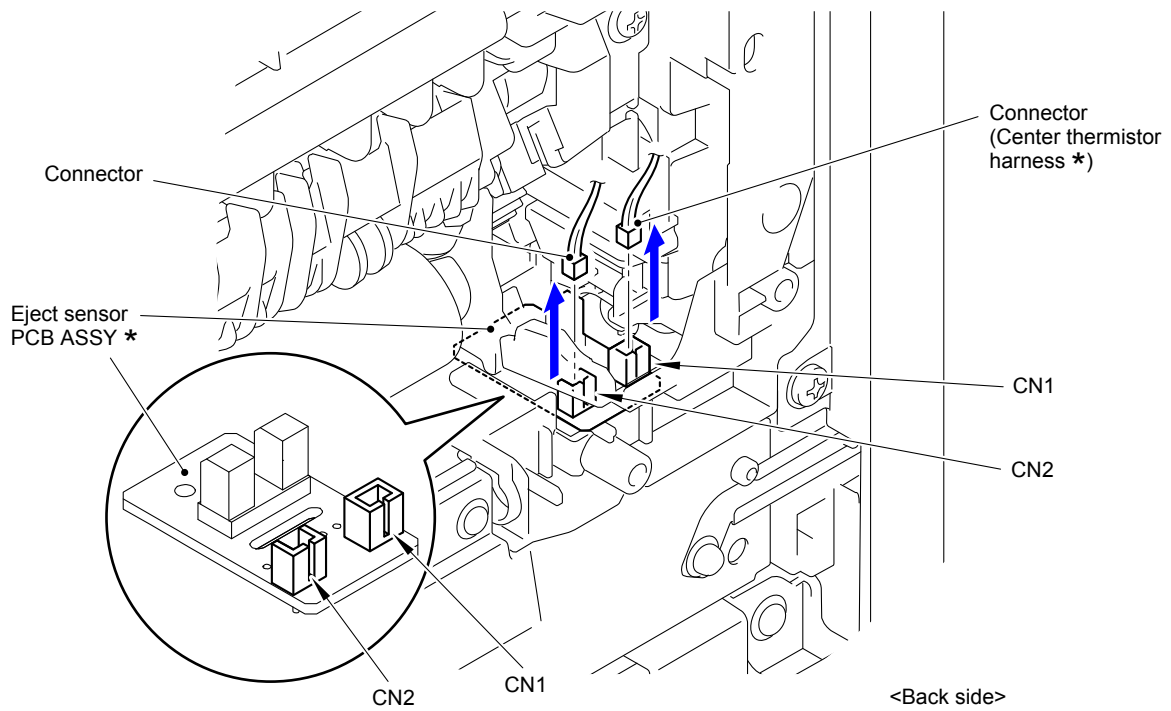

Fig. 7-13

Assembling Note:

* Center thermistor has a black and blue connectors (230V models only).
The black connector may be connected to the blue insertion port and vice versa.

(17) Disconnect the Electrode terminal of the Main body from the Electrode terminal of the Fuser unit.

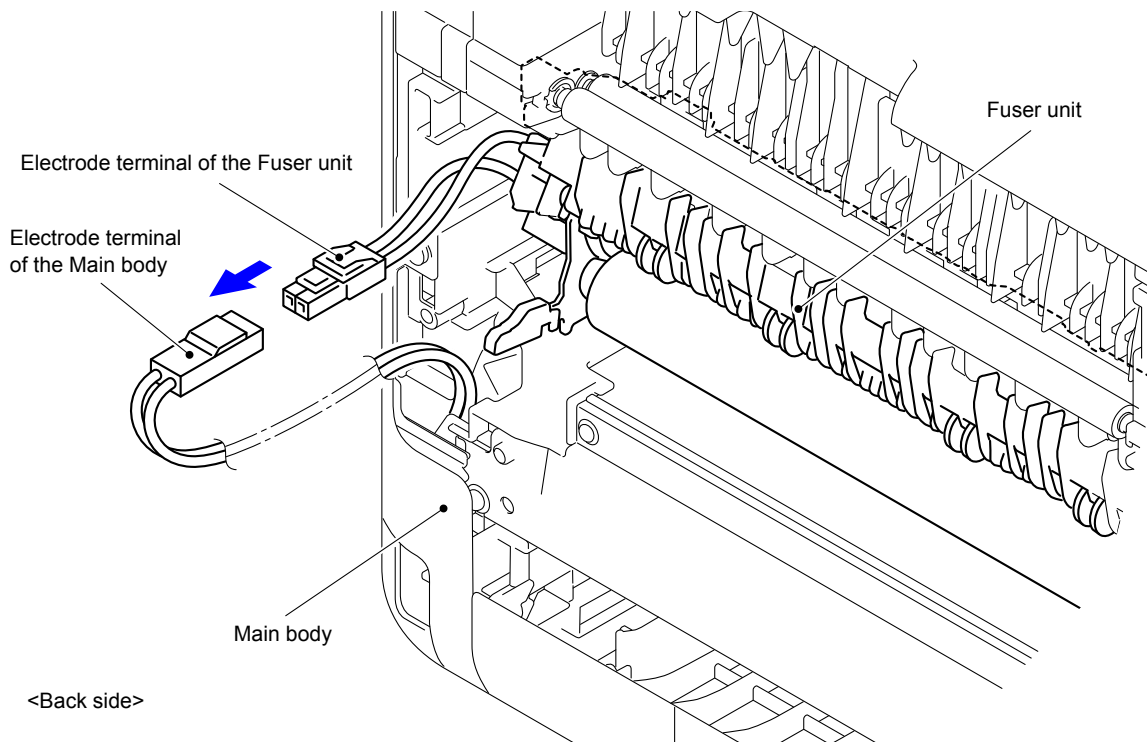

Fig. 7-14

(18) Remove the two Taptite pan B M4x14 screws to remove the Fuser unit from the Main body.

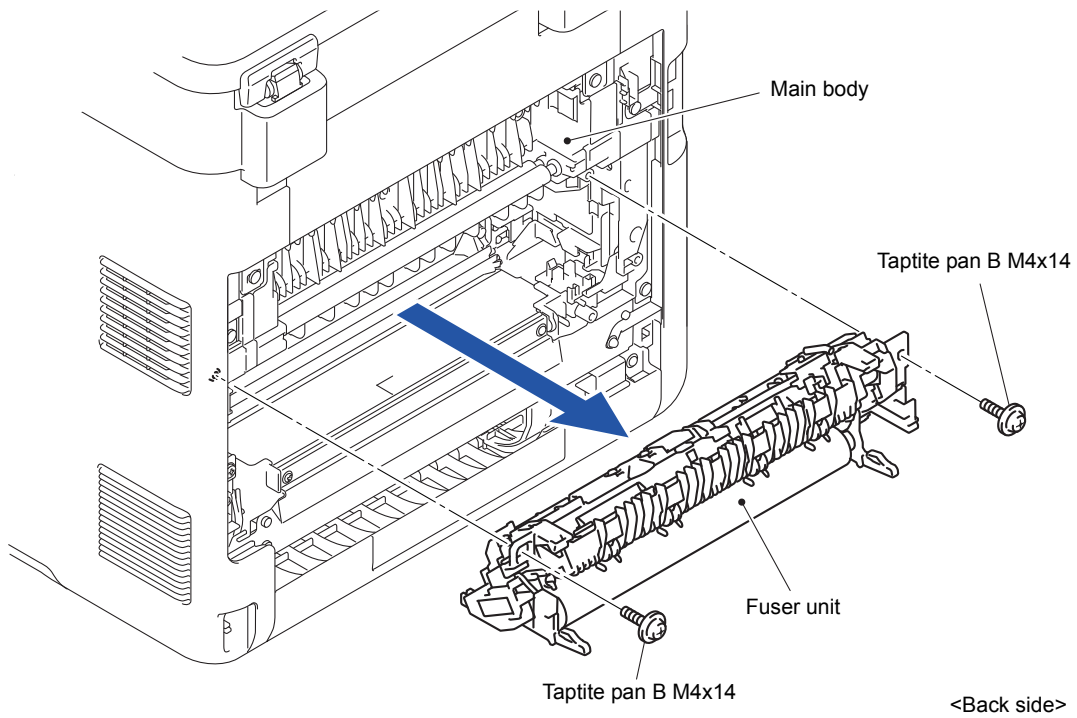

Fig. 7-15

Note:

- Do not apply a physical impact or vibration to the Fuser unit.
- Do not touch the roller and electrodes as shown in the figure below to prevent breakage of the Fuser unit.

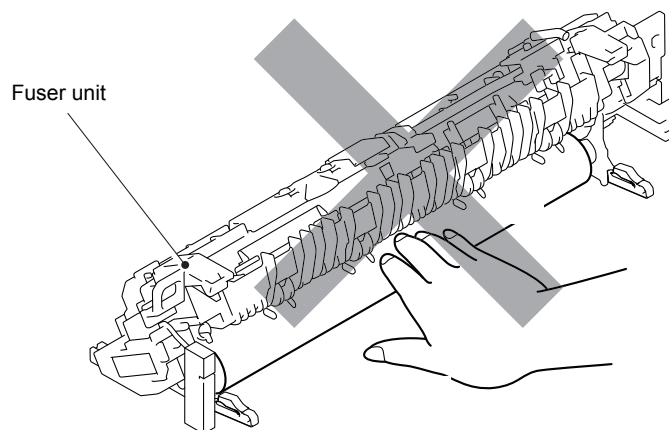

Fig. 7-16

(19) Release the five Hooks and remove the Toner filter ASSY from the Paper eject ASSY.

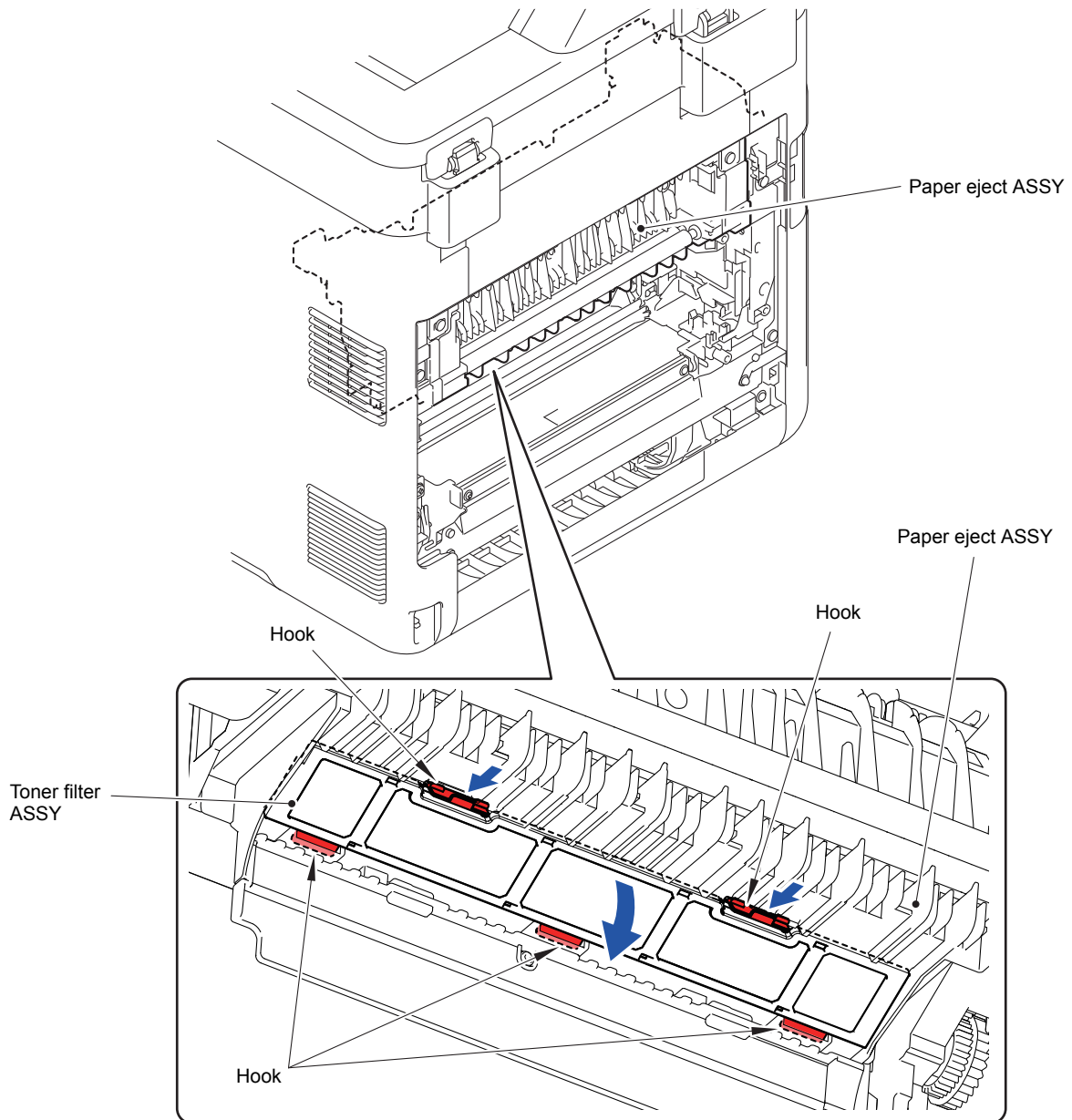

Fig. 7-17

(20) After replacing the Fuser unit, reset the counter. (Refer to “1.3.37 Reset counters for parts (Function code 88)” in Chapter 5.)

2.1.2 Laser unit

(1) Open the Back cover.

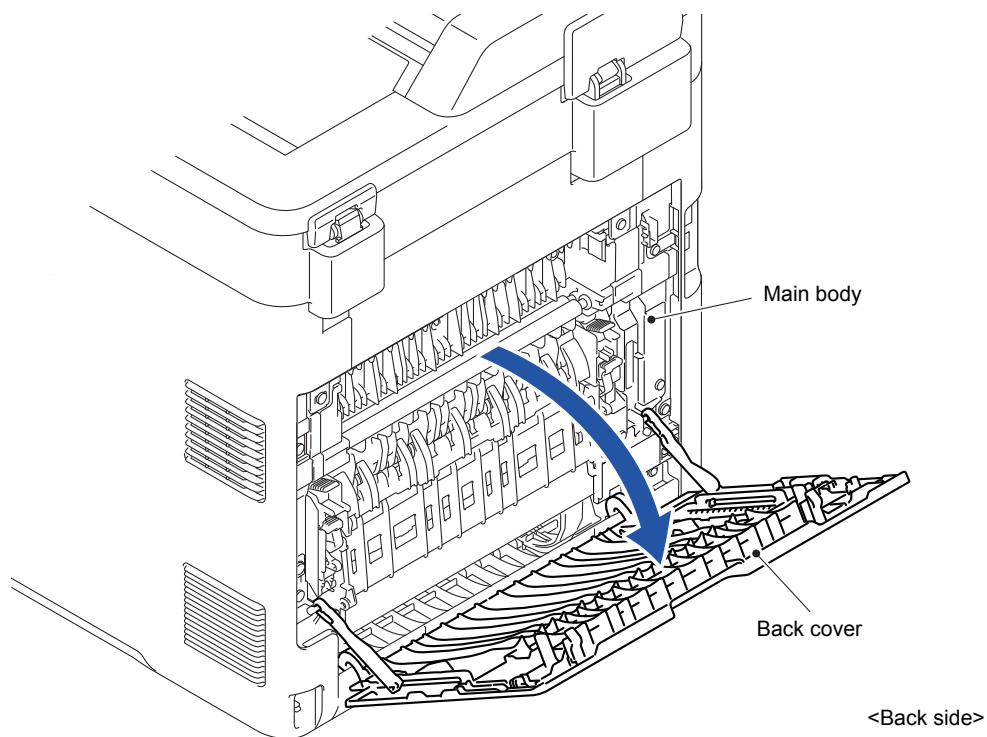

Fig. 7-18

(2) Remove the Back cover stopper arm L/R from the Main body.

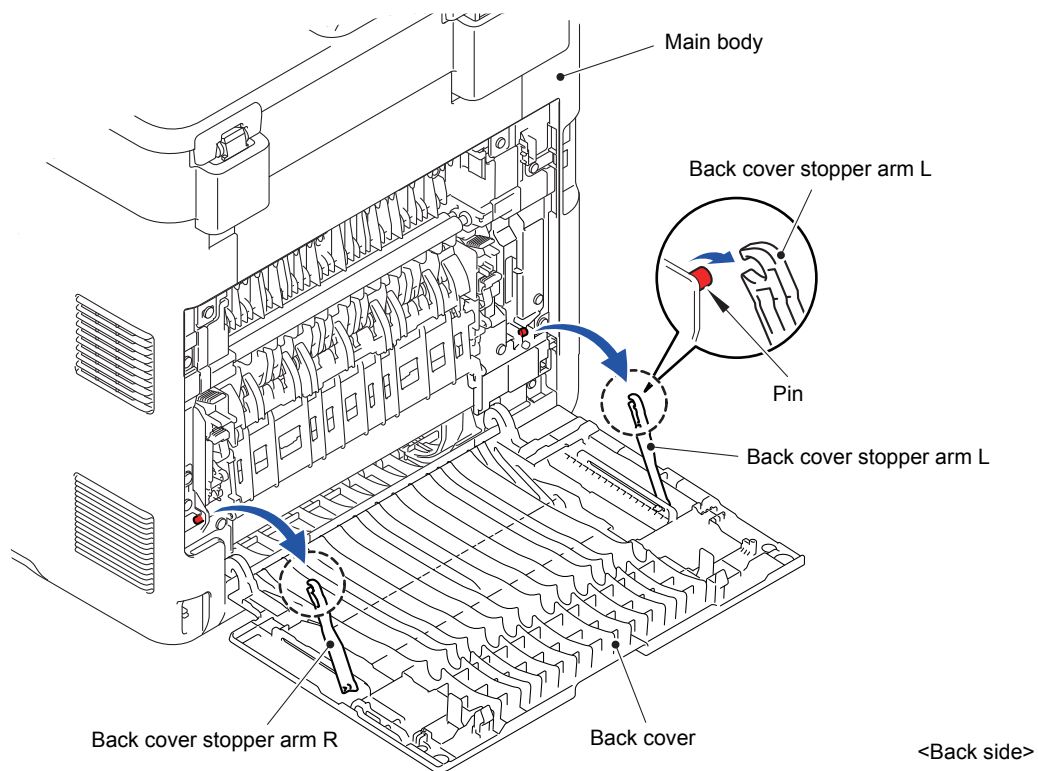

Fig. 7-19

(3) Remove the Shaft of the Back cover from the Bush on the right side of the Main body.

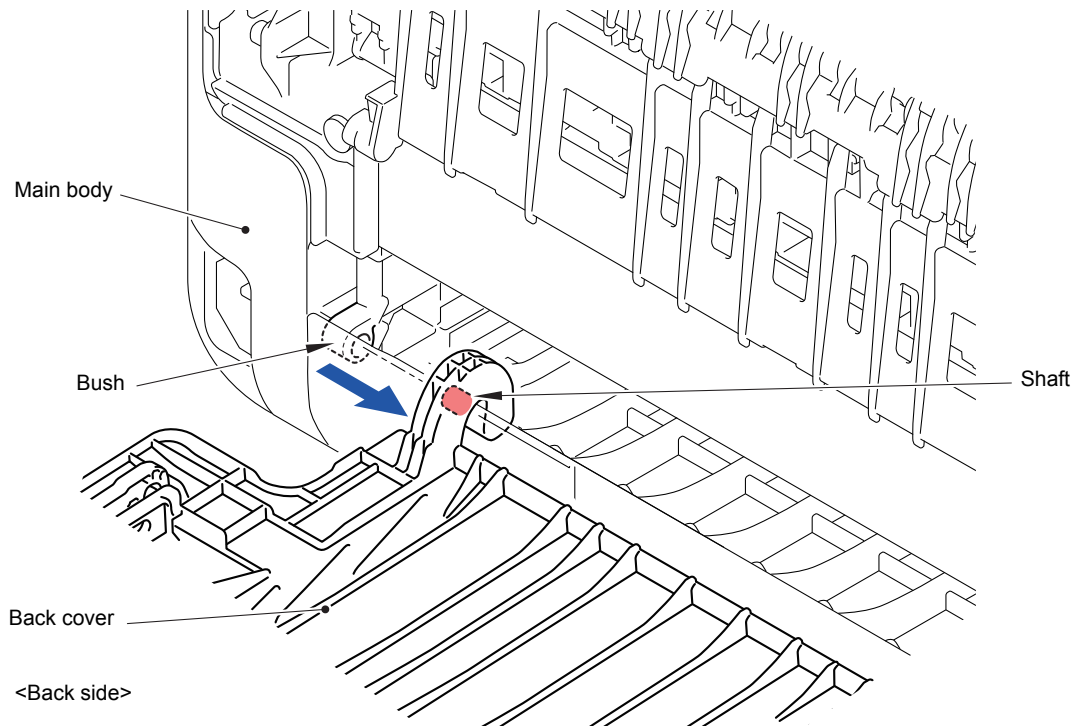

Fig. 7-20

(4) Remove the Back cover.

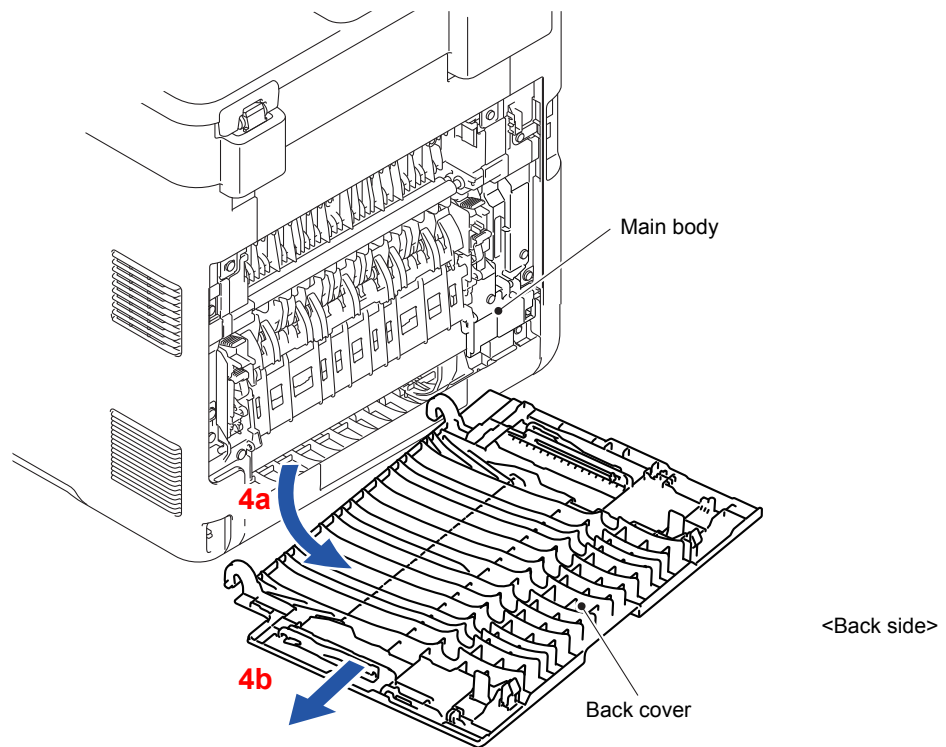

Fig. 7-21

- (5) Open the Front cover.

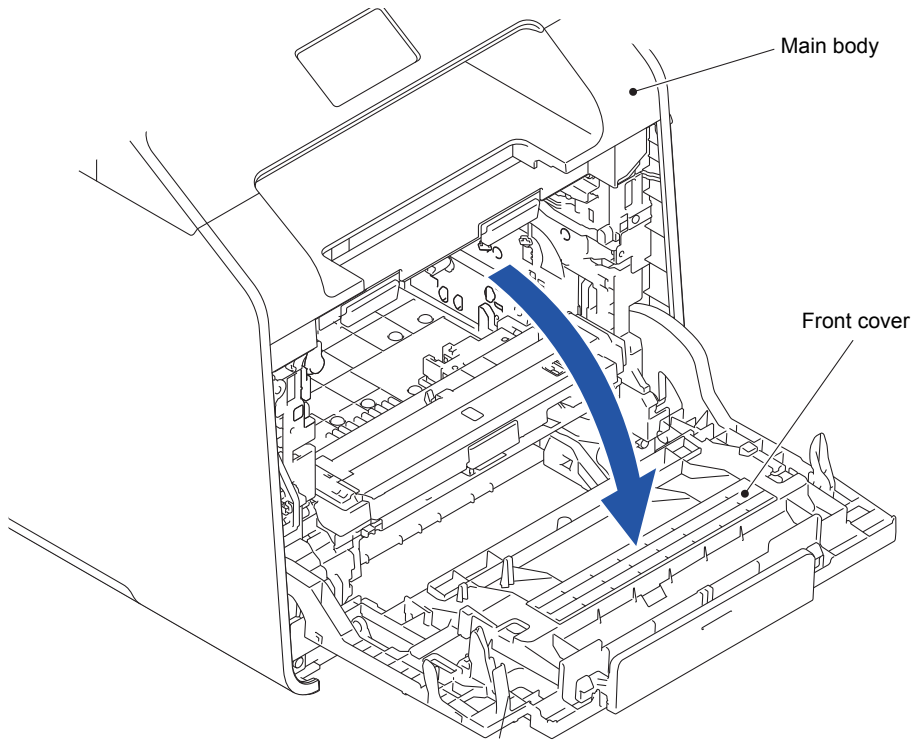

Fig. 7-22

- (6) Remove the one Taptite B 3x6 screw and the one Taptite bind B M4x12 screw from the front of the Side cover L.
- (7) Remove the Taptite bind B M4x12 screw from the side of the Side cover L.

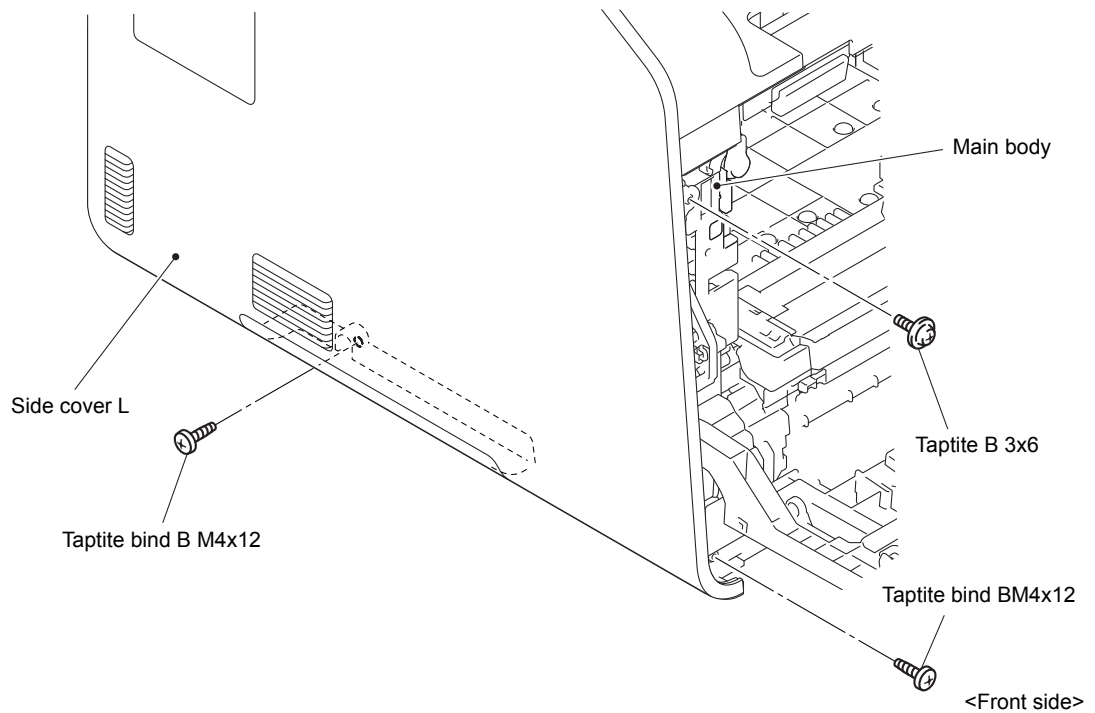

Fig. 7-23

(8) Remove the two Taptite bind B M4x12 screws from the back of the Side cover L.

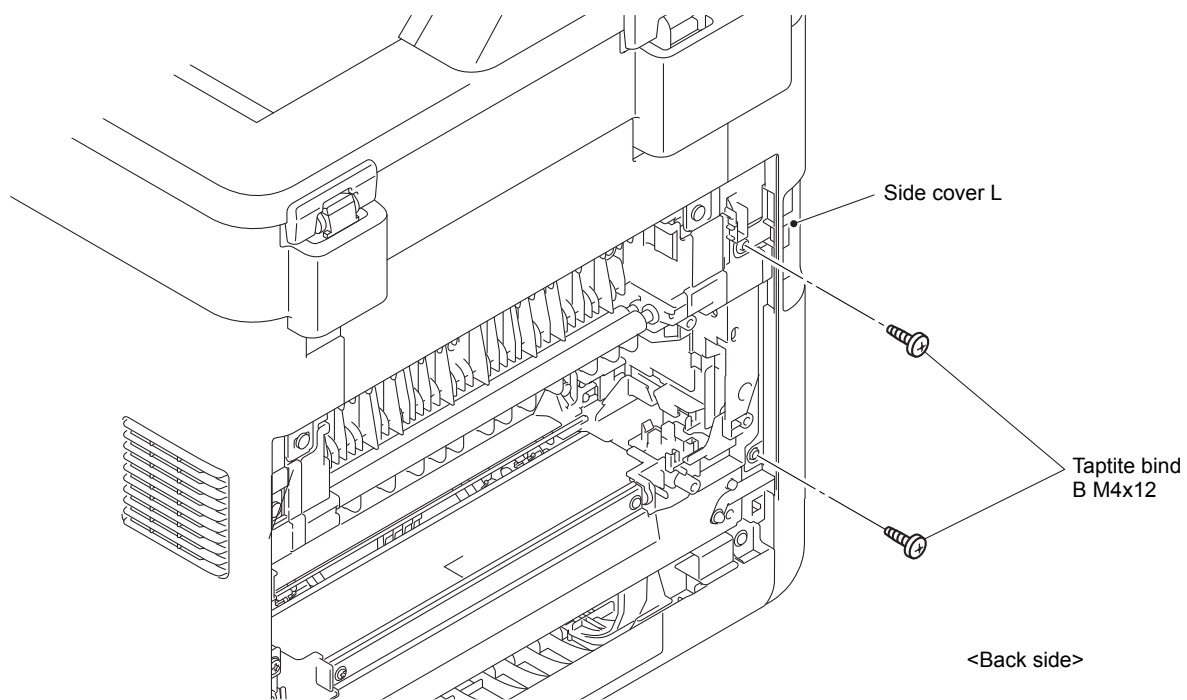

Fig. 7-24

(10) Remove the one Taptite B 3x6 screw and the one Taptite bind B M4x12 screw from the front of the Side cover R.

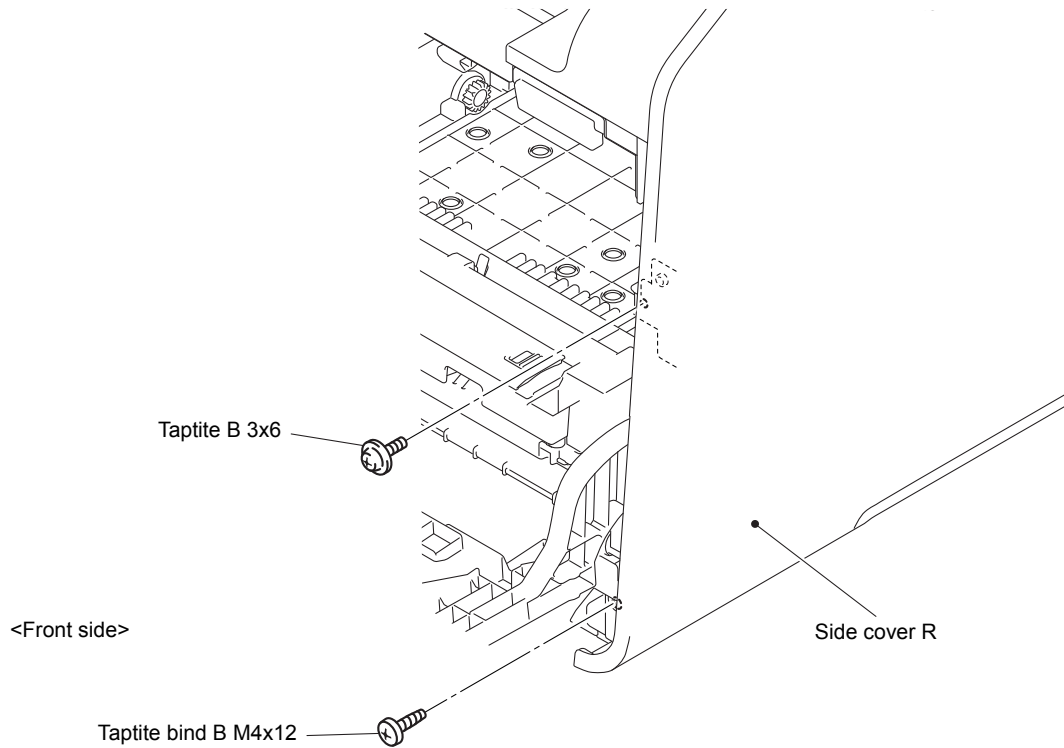

Fig. 7-27

(11) Remove the two Taptite bind B M4x12 screws from the back of the Side cover R.

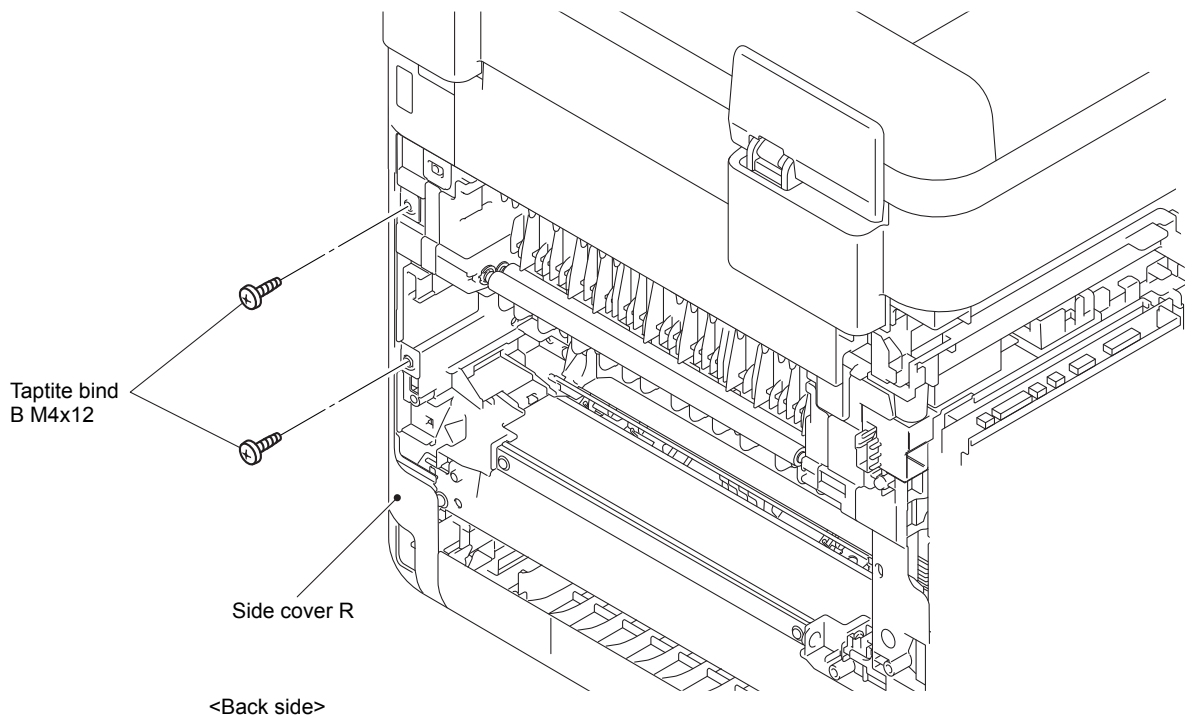

Fig. 7-28

(12) Release the Hooks 1 to 7 in numerical order. Move the Side cover R in the direction of the arrow 12a and release the other Hooks and remove Side cover R from the Main body.

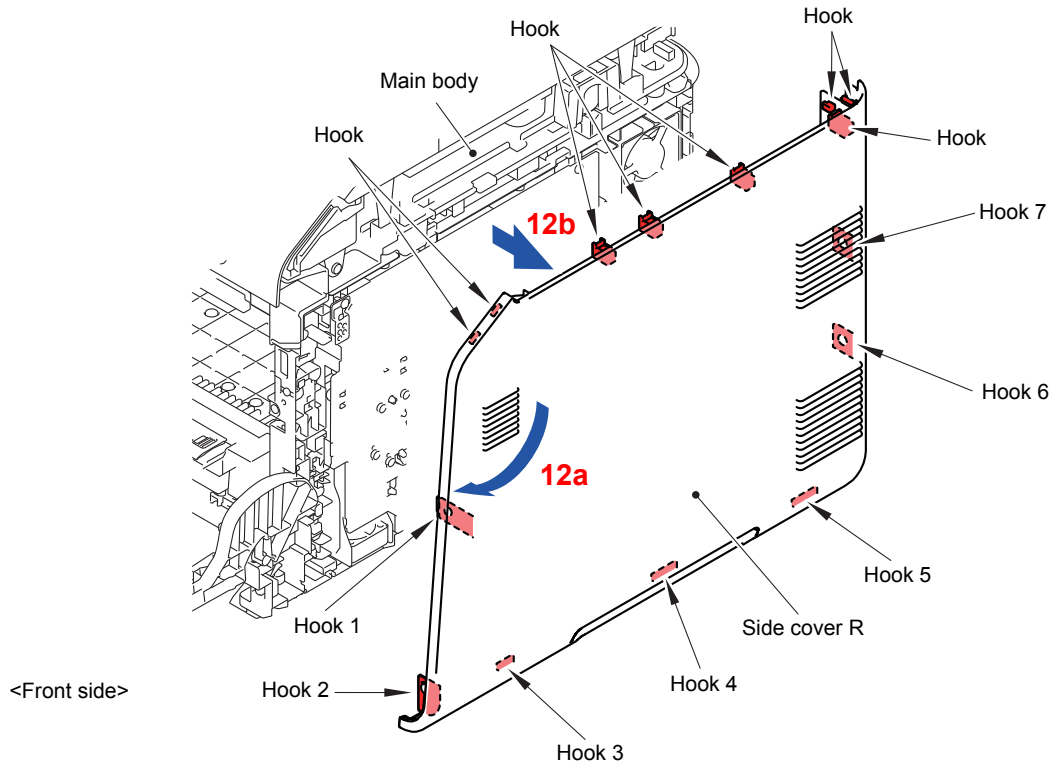

Fig. 7-29

* Inside of Side cover R

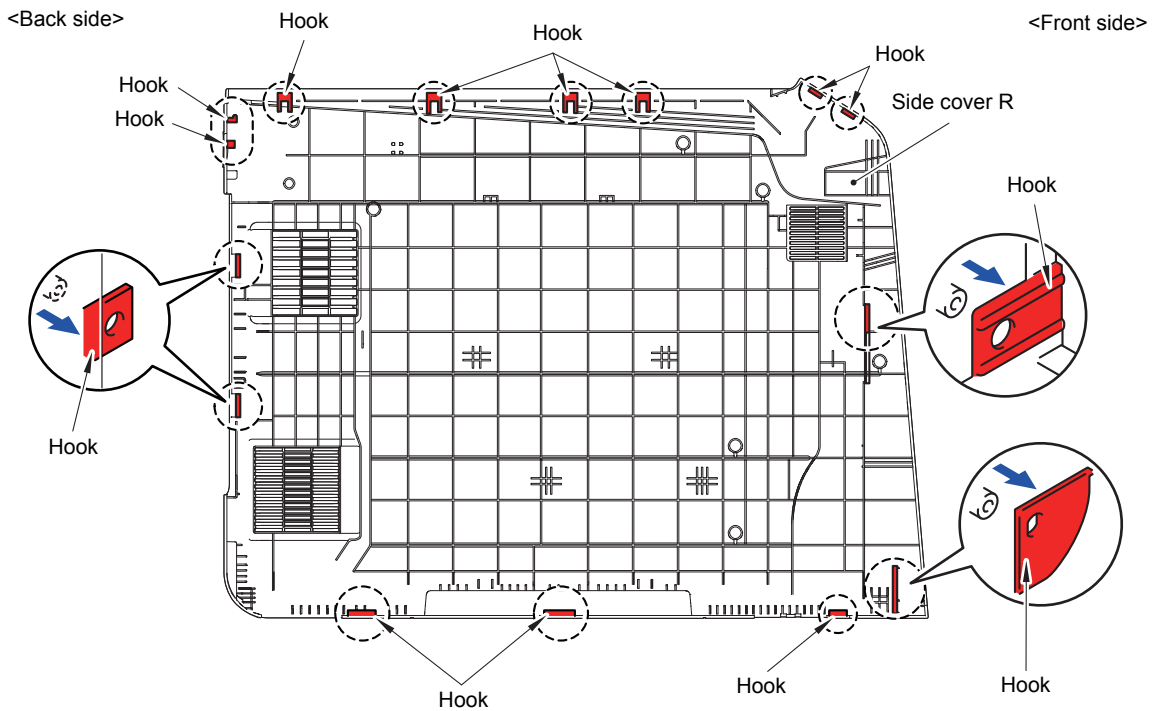

Fig. 7-30

Note:

As the Spacer tends to come off, be careful not to lose it.

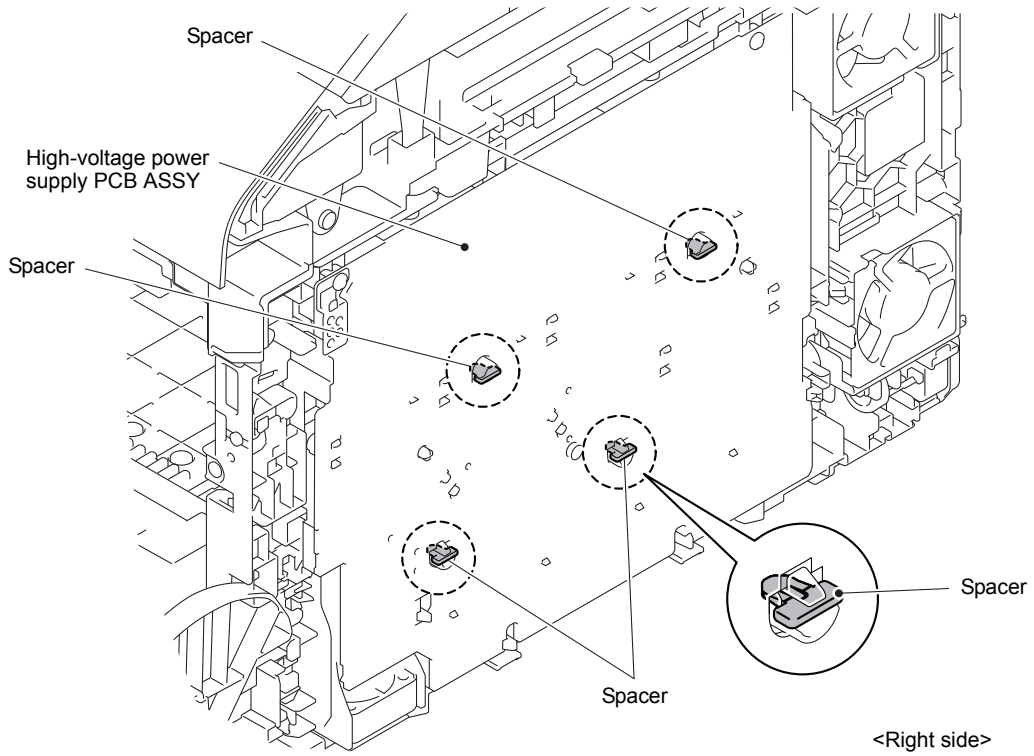

Fig. 7-31

(13) Open the Pull arm L and Pull arm R and release the Hooks from the joint of the Document scanner unit.

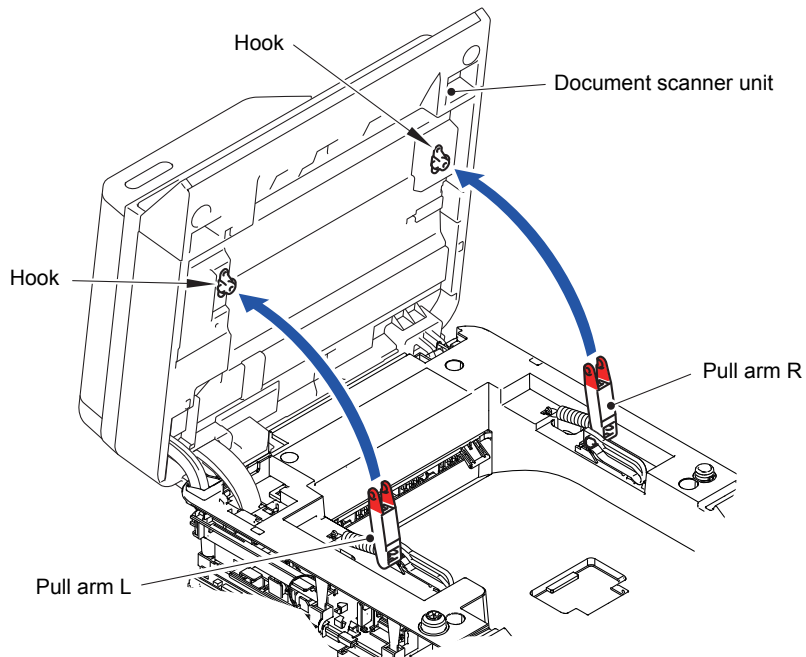

Fig. 7-32

- (14) Remove the Screw bind M3x8 screw and remove the Panel FG harness from the Main shield cover plate ASSY.
- (15) Remove the three Screw bind M3x8 screws and remove the Main shield cover plate ASSY from the Main body.

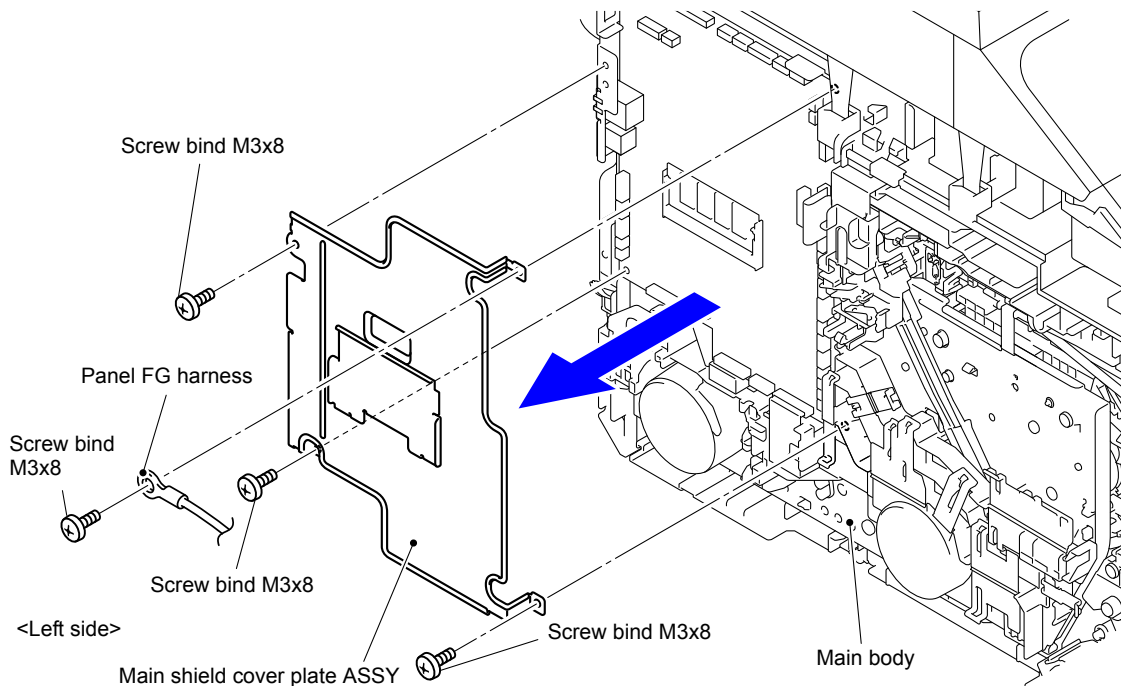

Fig. 7-33

- (16) Remove the two Screw bind M3x8 screws and remove the ADF earth harness and Document scanner FG harness from the Main PCB plate.
- (17) Disconnect the two Connectors (CN39 and CN41) from the Main PCB ASSY and release the wiring of the Main PCB insulation sheet.

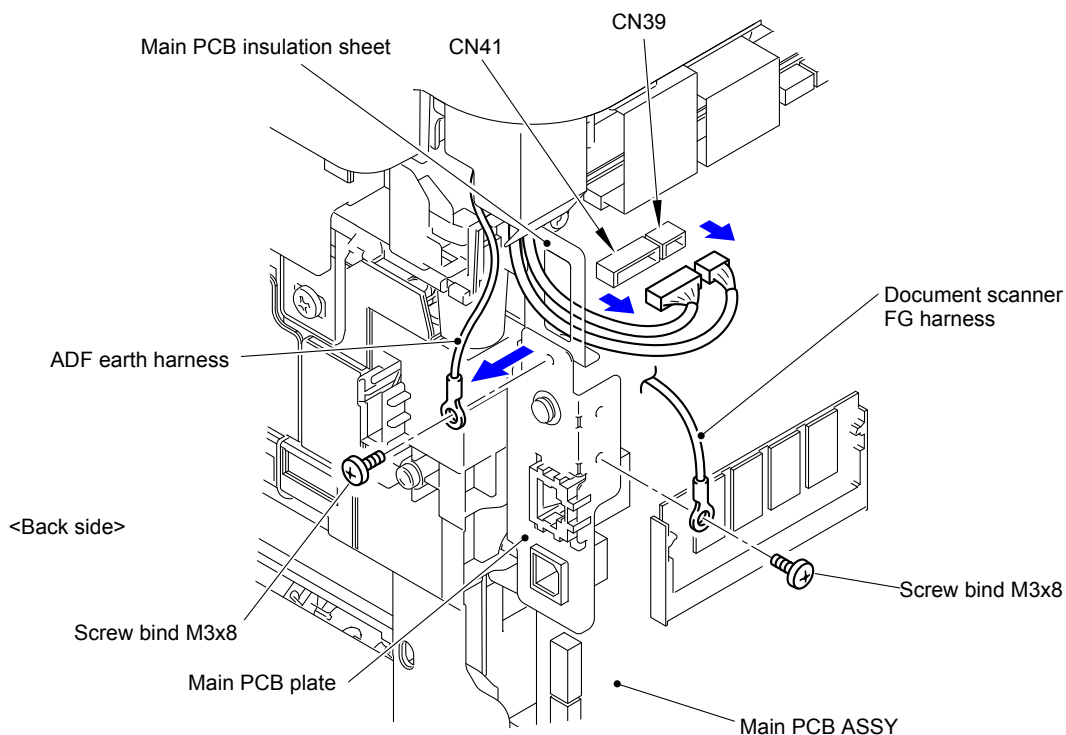

Fig. 7-34

- (18) Disconnect the four Connectors (CN20, CN27, CN32 and CN33) and two Flat cables (CN37 and CN38) from the Main PCB ASSY.

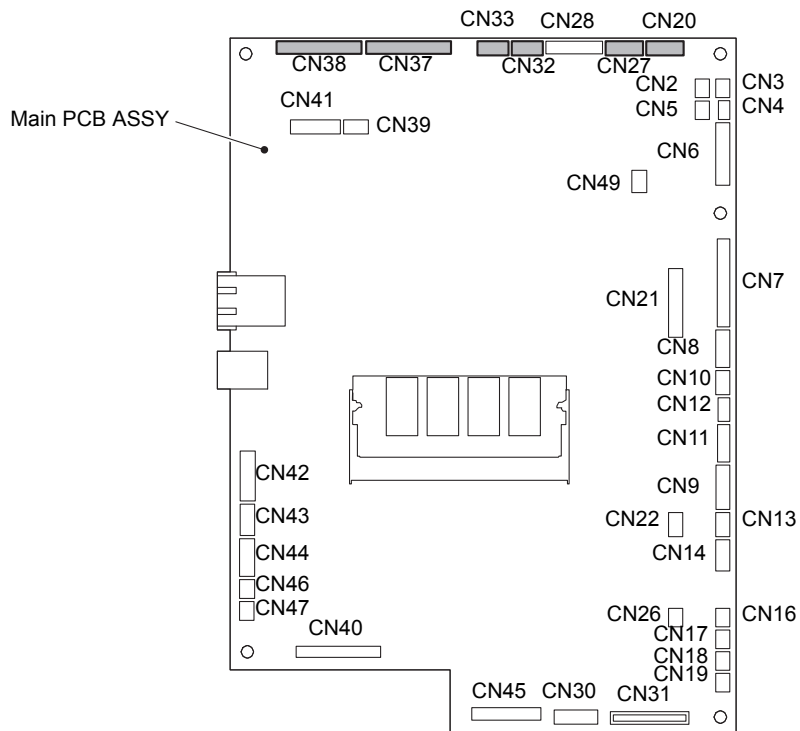

Fig. 7-35

- (19) Open the Document scanner unit and pull out the First side CIS flat cable and Second side CIS flat cable from the Flat core.

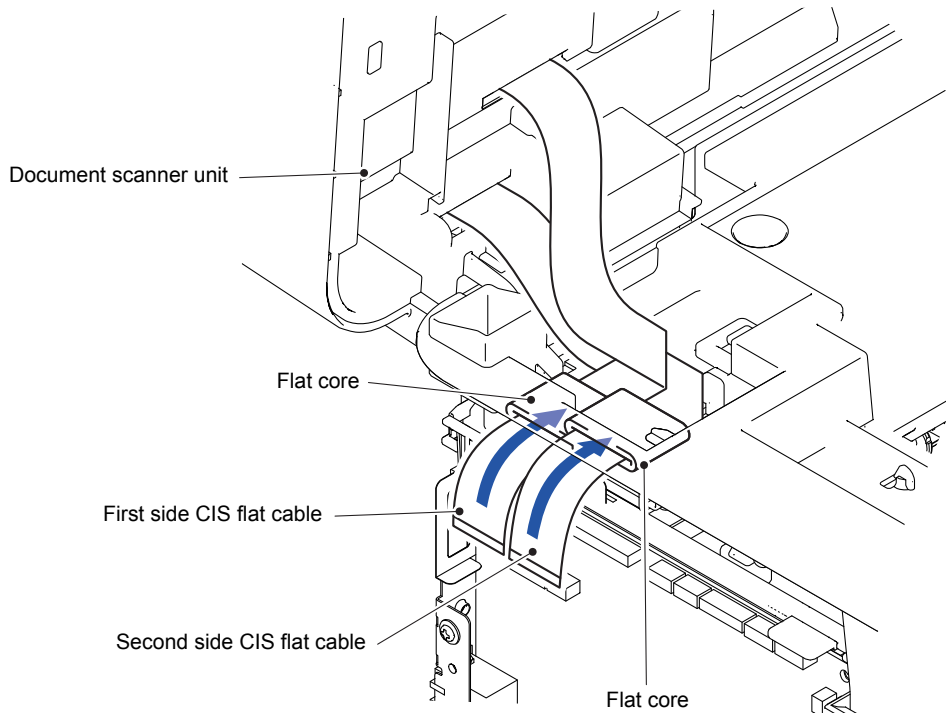

Fig. 7-36

(20) Release all the wiring passes through the Hole of the Joint cover top.

(21) Change the angle of the Document scanner unit as shown in the figure to remove it from the Main body.

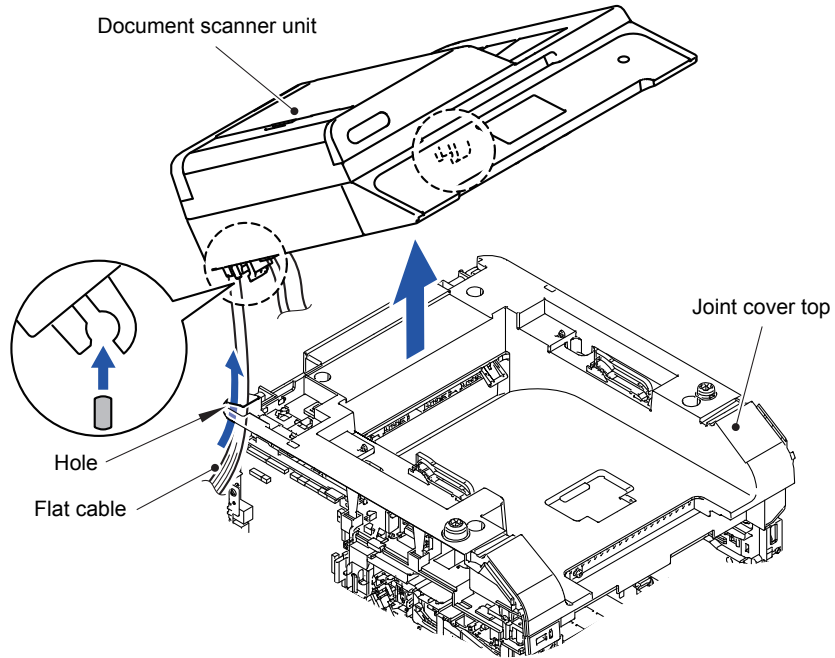

Fig. 7-37

(22) Remove the eight Taptite bind B M4x12 screws from the Joint cover top.

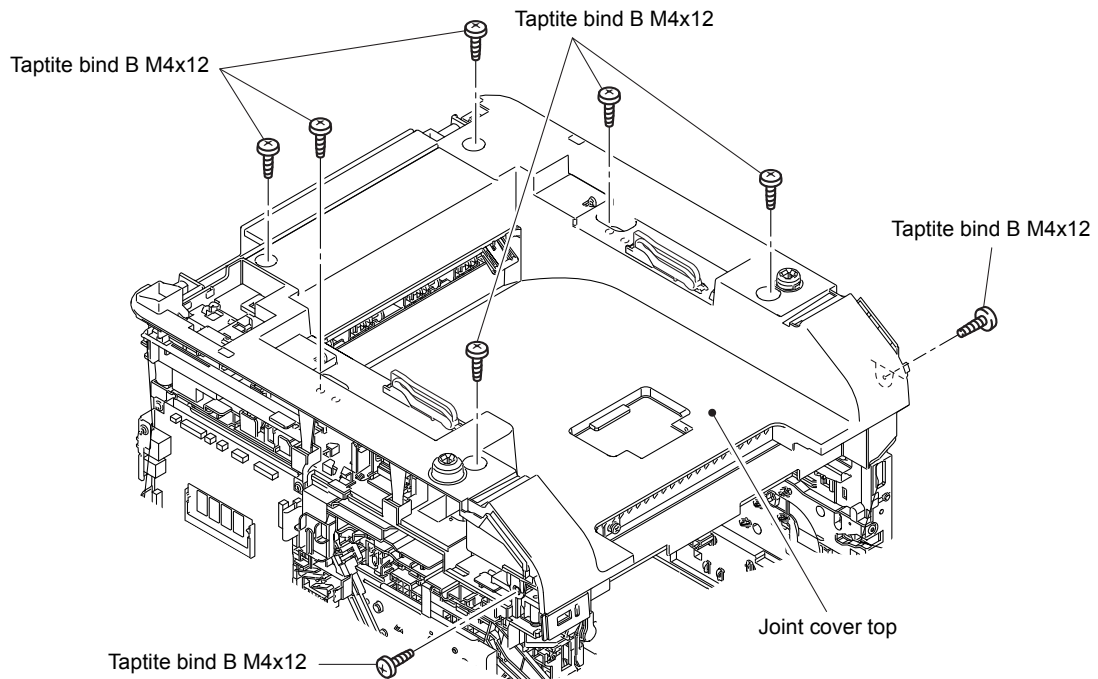

Fig. 7-38

(23) Release the eight Hooks and remove the Joint cover top from the Main body.

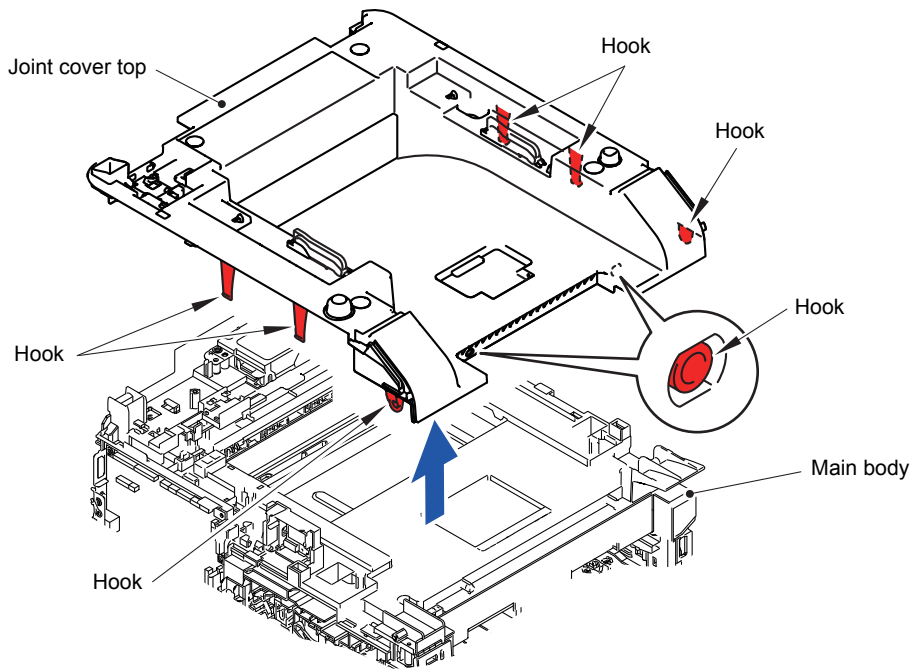

Fig. 7-39

(24) Remove the Screw pan (S/P washer) M3.5x6 screw and remove the Modem FG harness from the Main PCB plate.

(25) Disconnect the Modem flat cable (CN28) from the Main PCB ASSY.

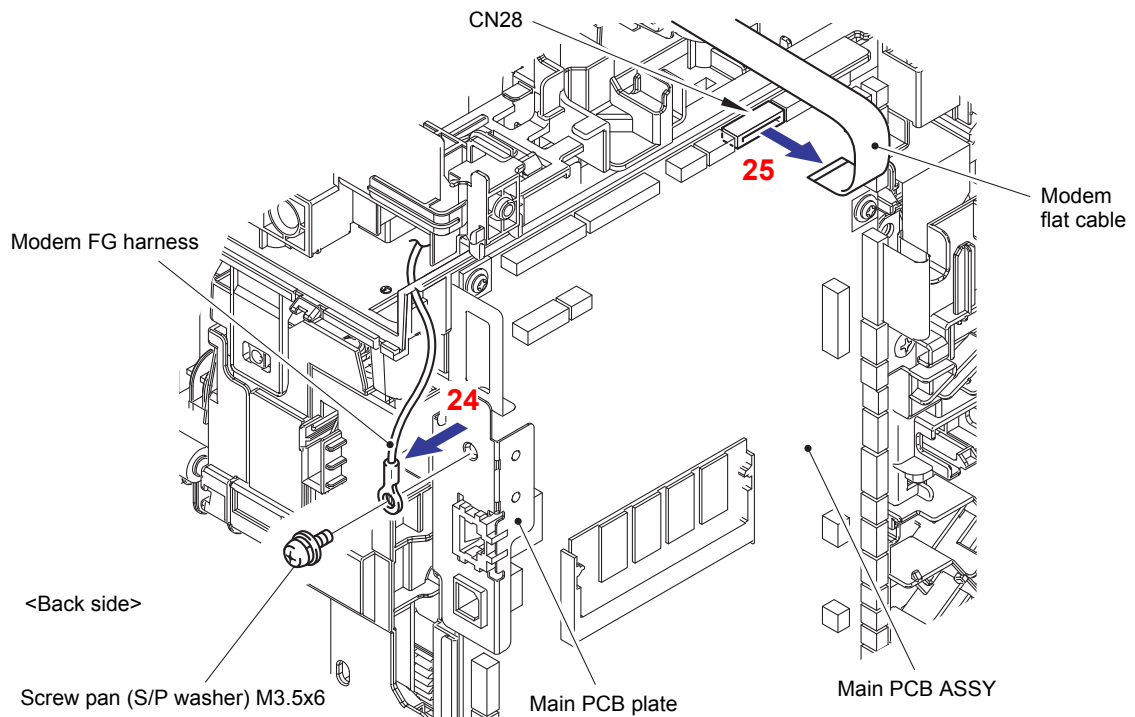

Fig. 7-40

(26) Remove the Screw pan (S/P washer) M3.5x6 screw and remove the Modem ground harness from the High-voltage power supply PCB ASSY.

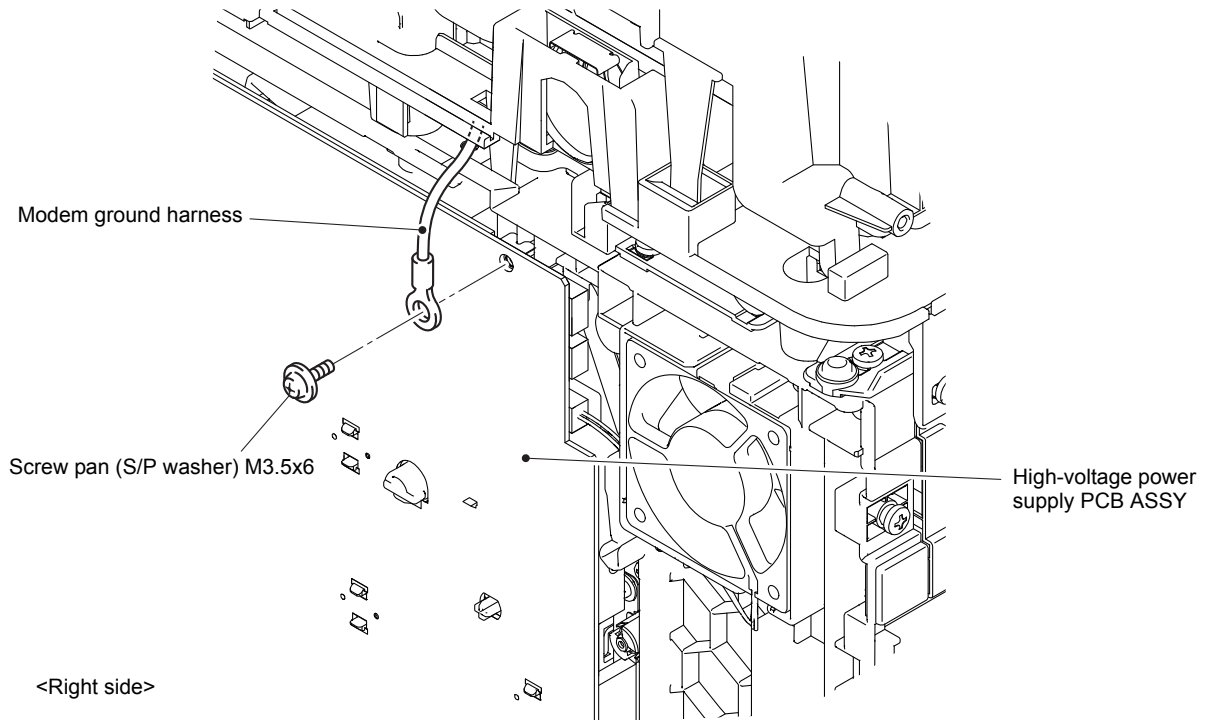

Fig. 7-41

(27) Disconnect the wiring of the Modem ground harness.

(28) Remove the four Taptite bind B M4x12 screws from the Back cover upper.

(29) Release the two Hooks and remove the Back cover upper from the Main body.

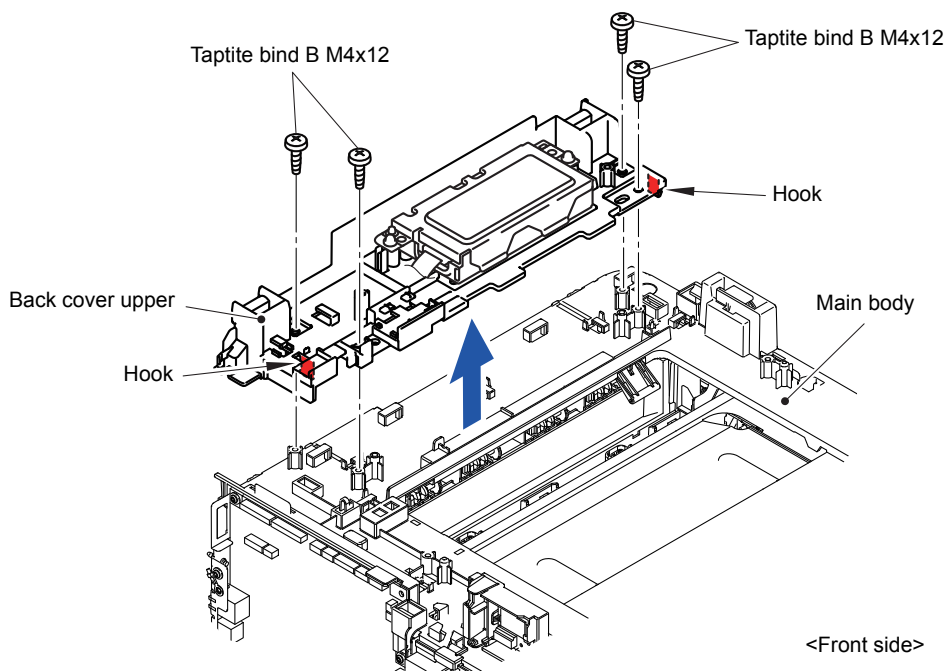

Fig. 7-42

(30) Disconnect the three Connectors (CN4, CN9 and CN11) from the Main PCB ASSY.

(31) Disconnect the wiring of the Main USB host harness ASSY.

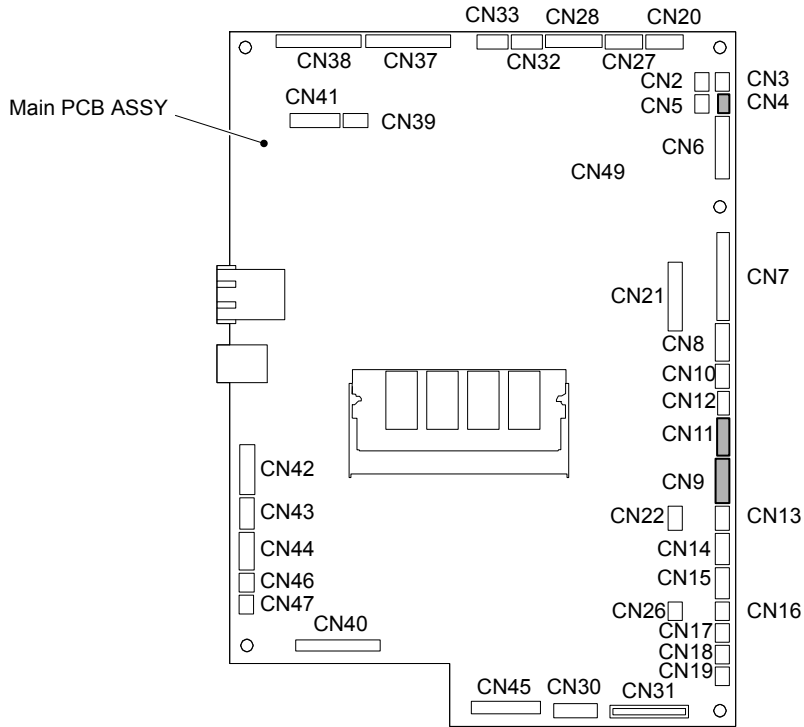

Fig. 7-43

(32) Remove the seven Taptite bind B M4x12 screws from the Joint cover base ASSY.

(33) Remove the two Taptite bind B M4x12 screws from the back of the Joint cover base ASSY.

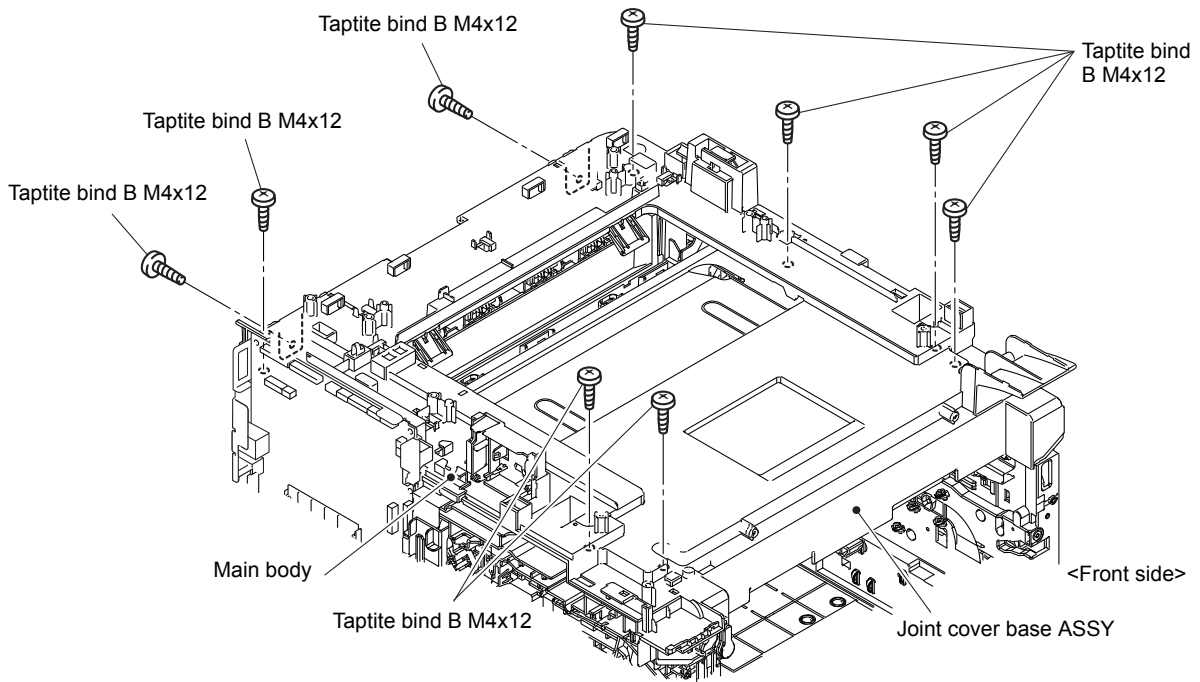

Fig. 7-44

(34) Release the three Hooks 1. Release the other seven Hooks and remove the Joint cover base ASSY from the Main body.

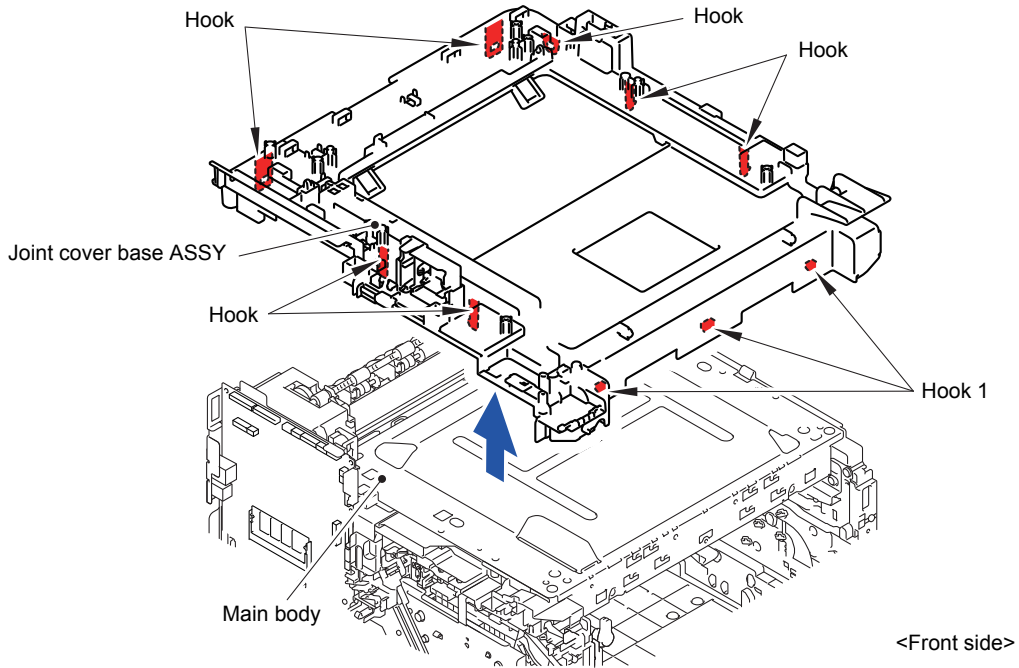

Fig. 7-45

(35) Remove the six Taptite bind B M4x12 screws and four Taptite cup S M3x6 SR screws, and remove the Scanner cover plate from the Main body.

Assembling Note:

When assembling the six screws of the Taptite bind B M4x12, be sure to assemble them in the order shown in the figure.

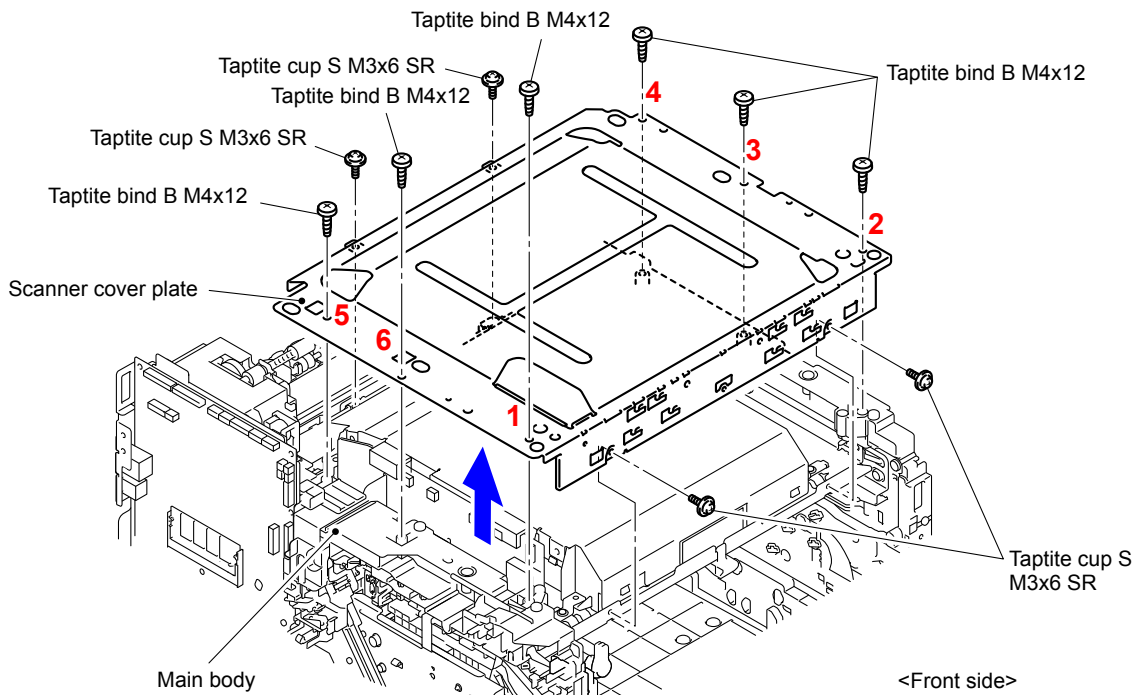

Fig. 7-46

(36) Disconnect the Laser unit flat cable from the Laser unit.

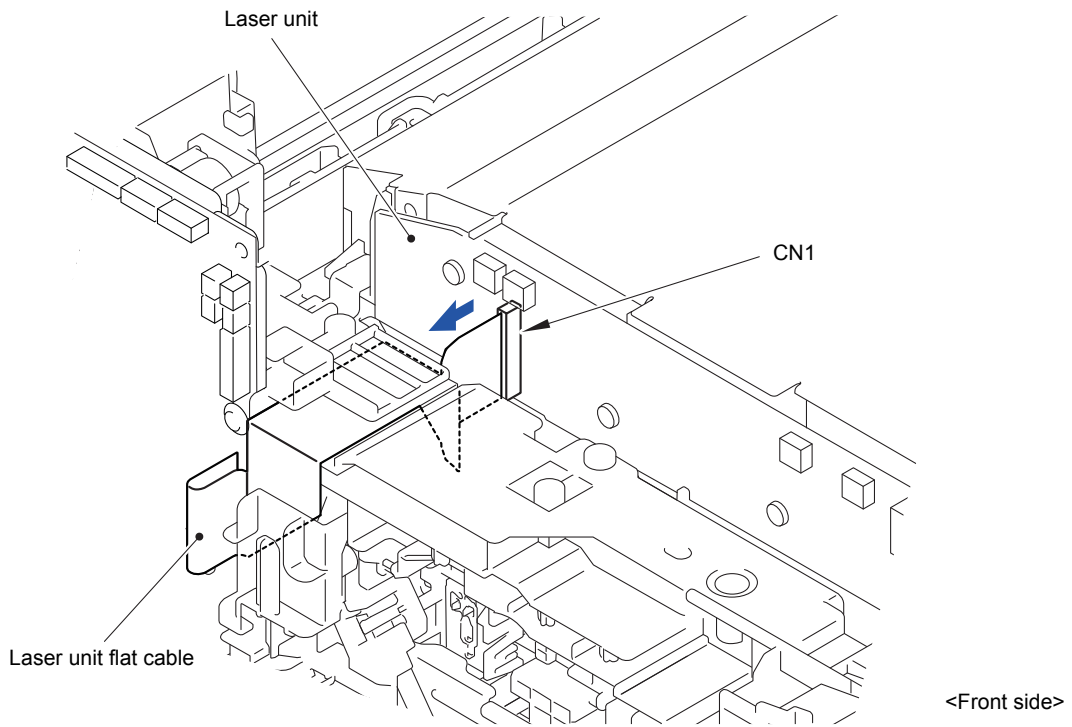

Fig. 7-47

(37) Remove the five Taptite cup S M3x6 SR screws and remove the four Scanner holders from the Scanner plate.

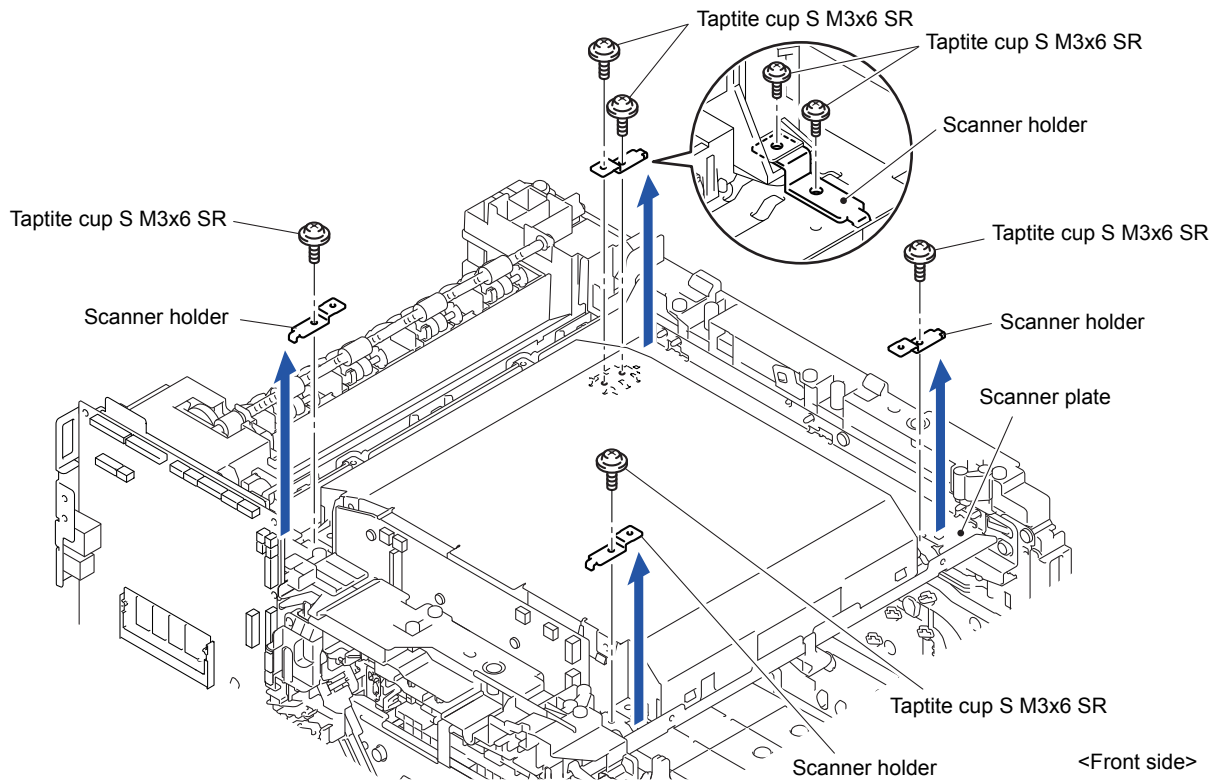

Fig. 7-48

Assembling Note:

- When assembling the Scanner holder to "A" of the Laser unit, be sure to use the Scanner holder of which "B" is a screw and not to use other Scanner holders.
- When assembling the Scanner holder to "A" of the Laser unit, be sure that the Scanner holder is placed as shown in the figure.

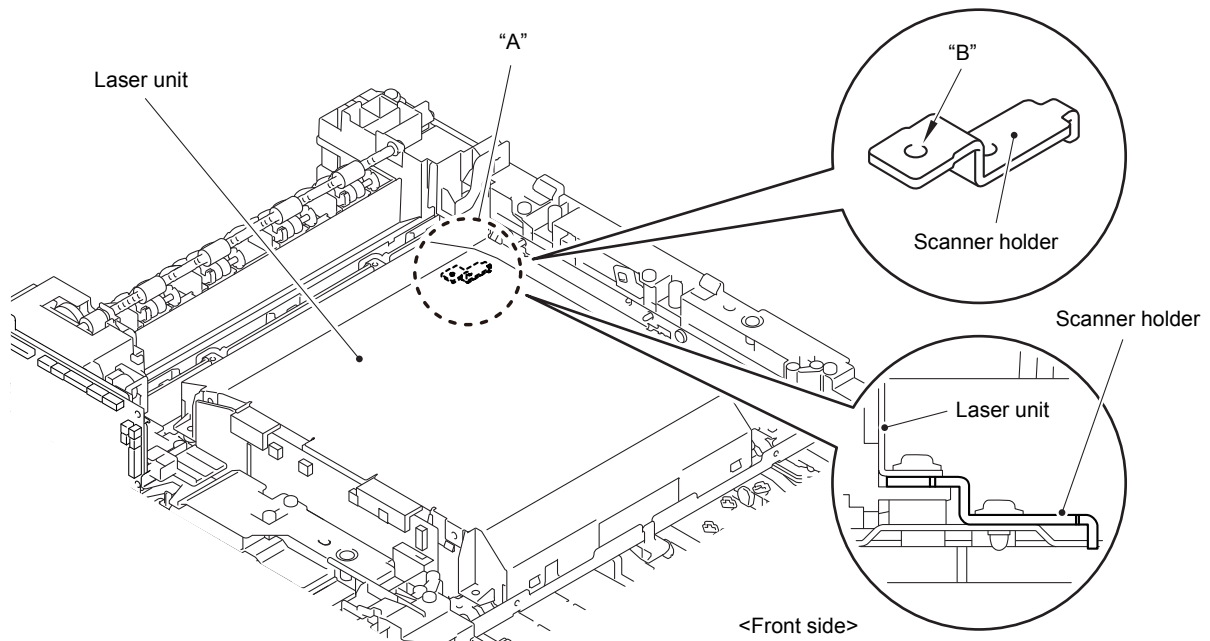

Fig. 7-49

- (38) Disconnect the Connector (CN8).
- (39) Remove the Laser unit from the Scanner plate.

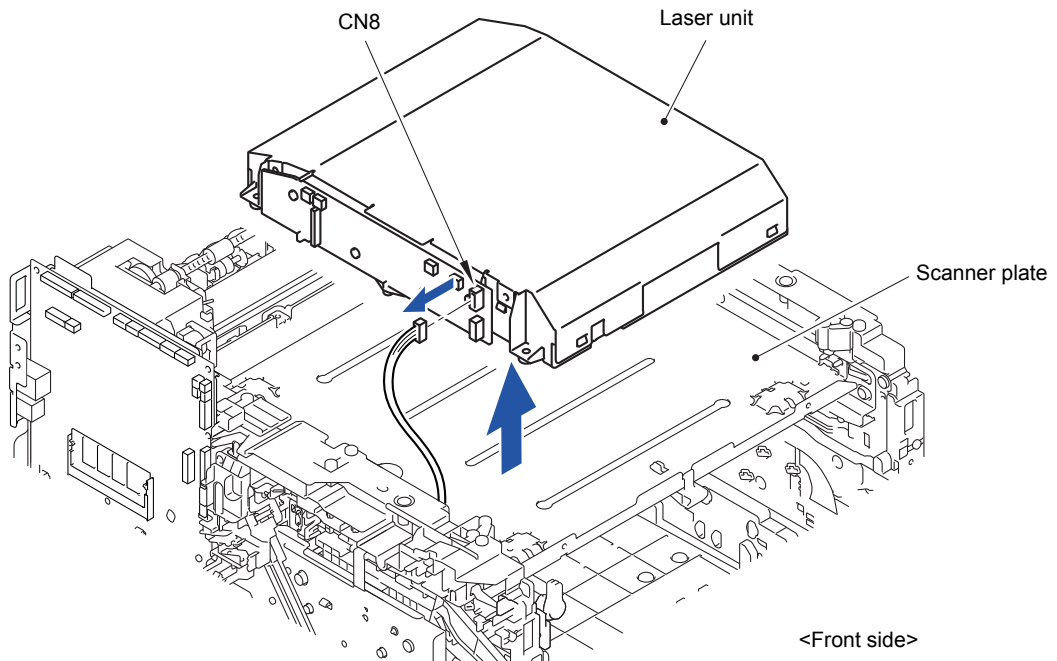

Fig. 7-50

- (40) After replacing the Laser unit, reset the counter. (Refer to ["1.3.37 Reset counters for parts \(Function code 88\)"](#) in Chapter 5.)

■ Legal model

- (9) Release the Hooks 1 to 8 in numerical order. Move the Side cover L in the direction of the arrow 9a and release the other Hooks and remove Side cover L from the Main body.

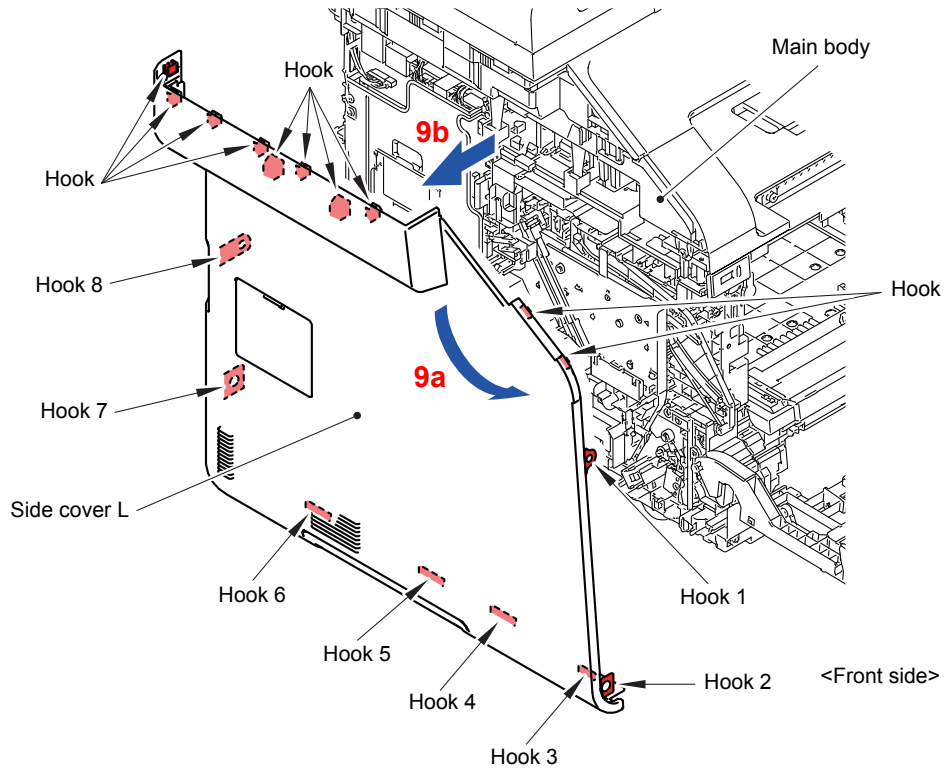

Fig. 7-51

* Inside of Side cover L

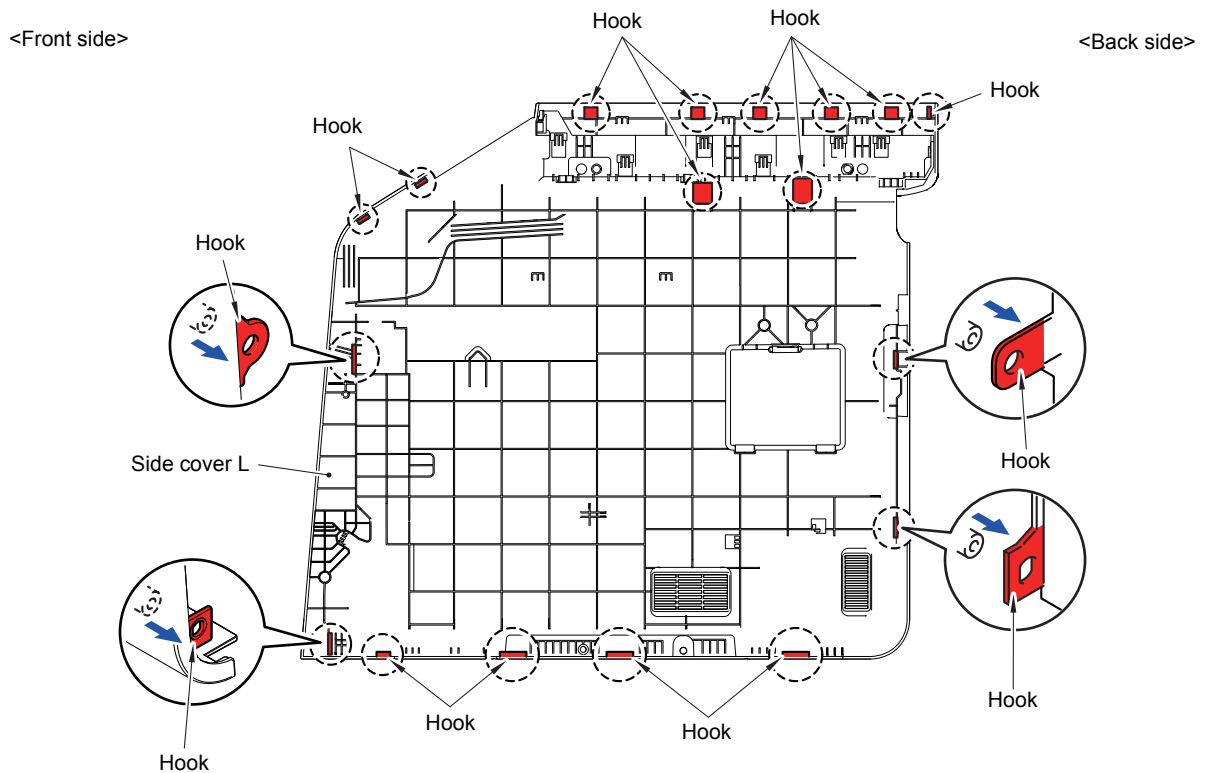

Fig. 7-52

(10) Remove the one Taptite B 3x6 screw and the one Taptite bind B M4x12 screw from the front of the Side cover R.

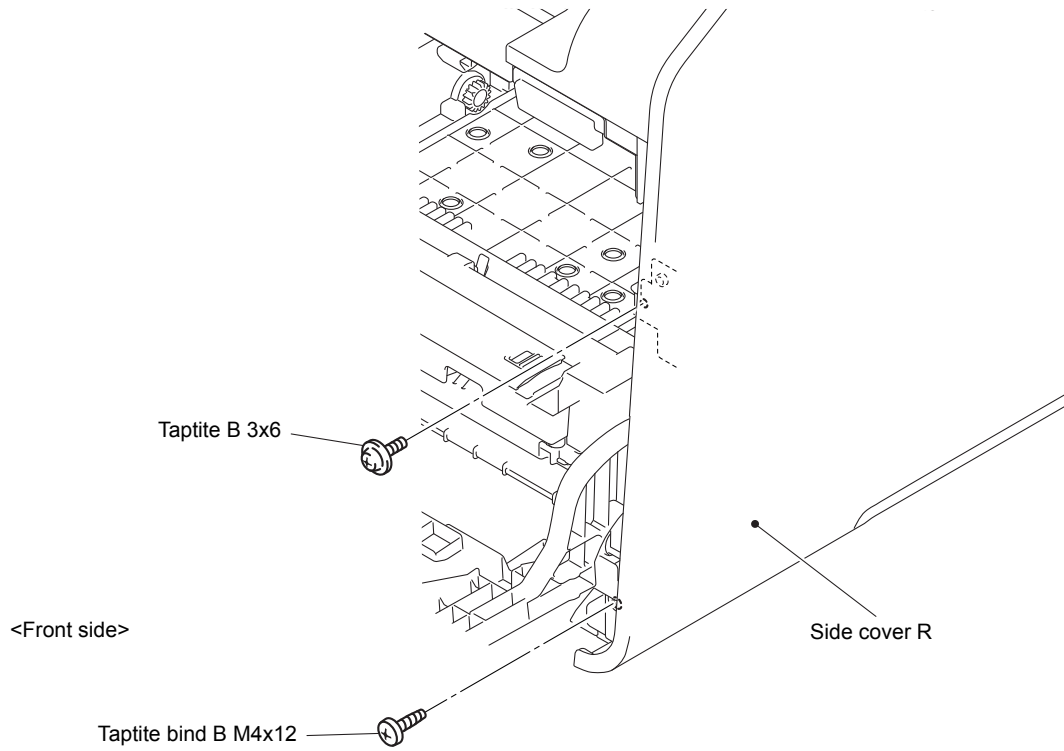

Fig. 7-53

(11) Remove the two Taptite bind B M4x12 screws from the back of the Side cover R.

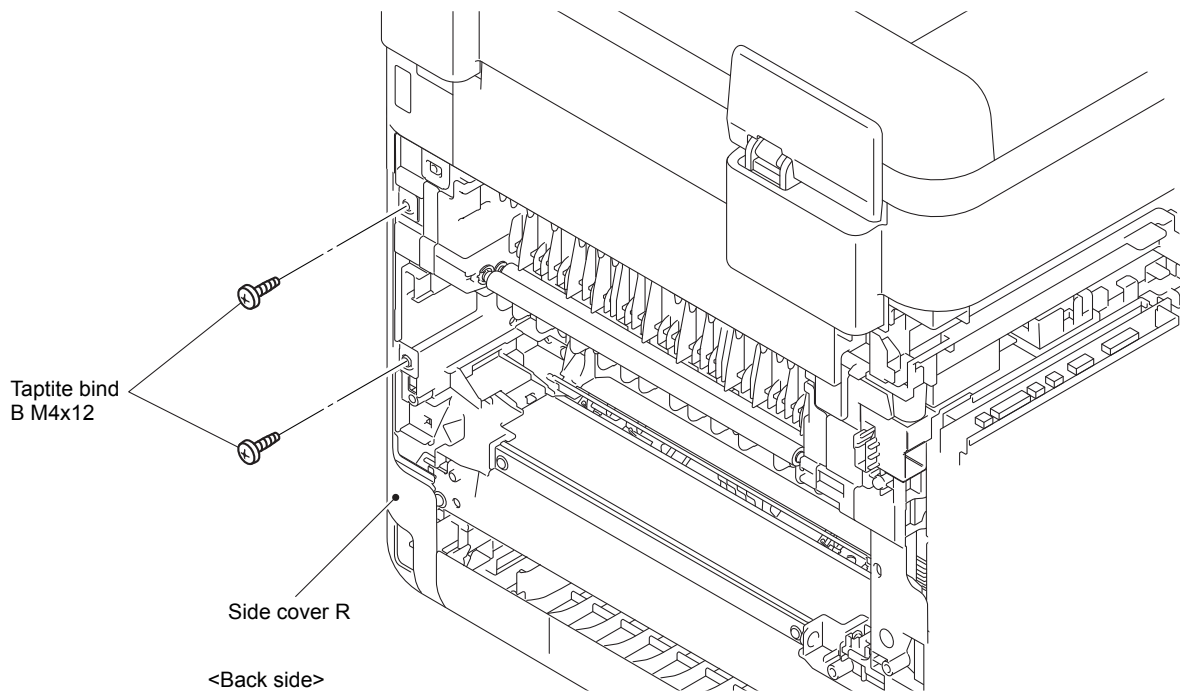

Fig. 7-54

(12) Release the Hooks 1 to 7 in numerical order. Move the Side cover R in the direction of the arrow 12a and release the other Hooks and remove Side cover R from the Main body.

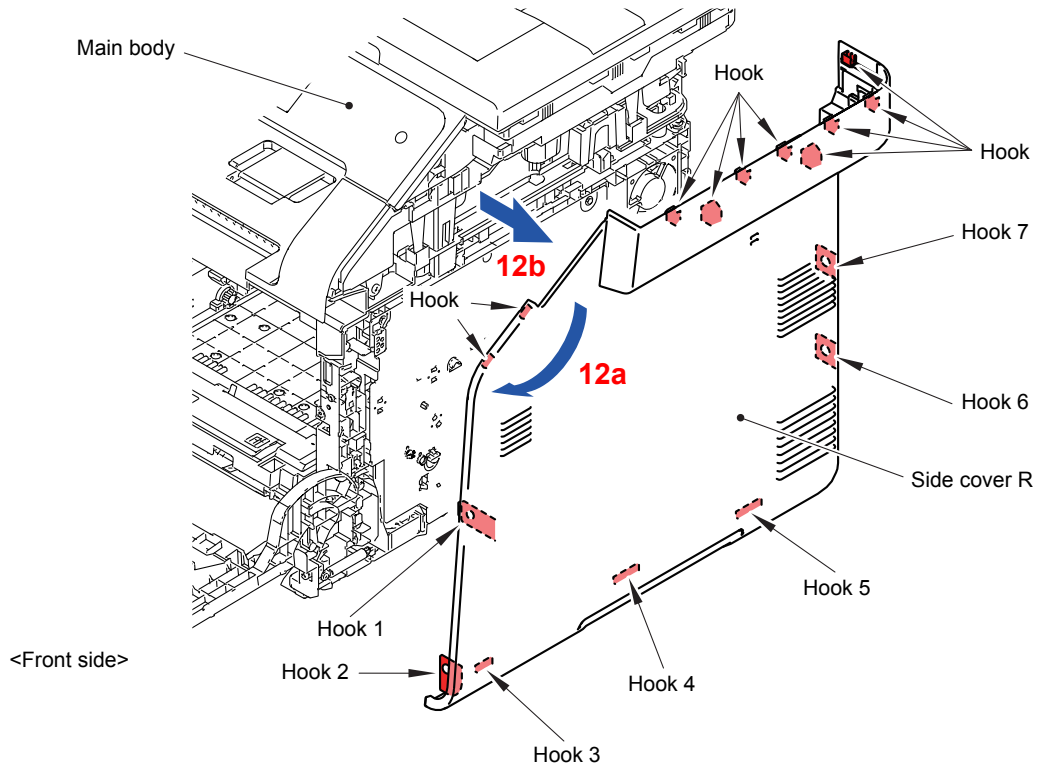

Fig. 7-55

* Inside of Side cover R

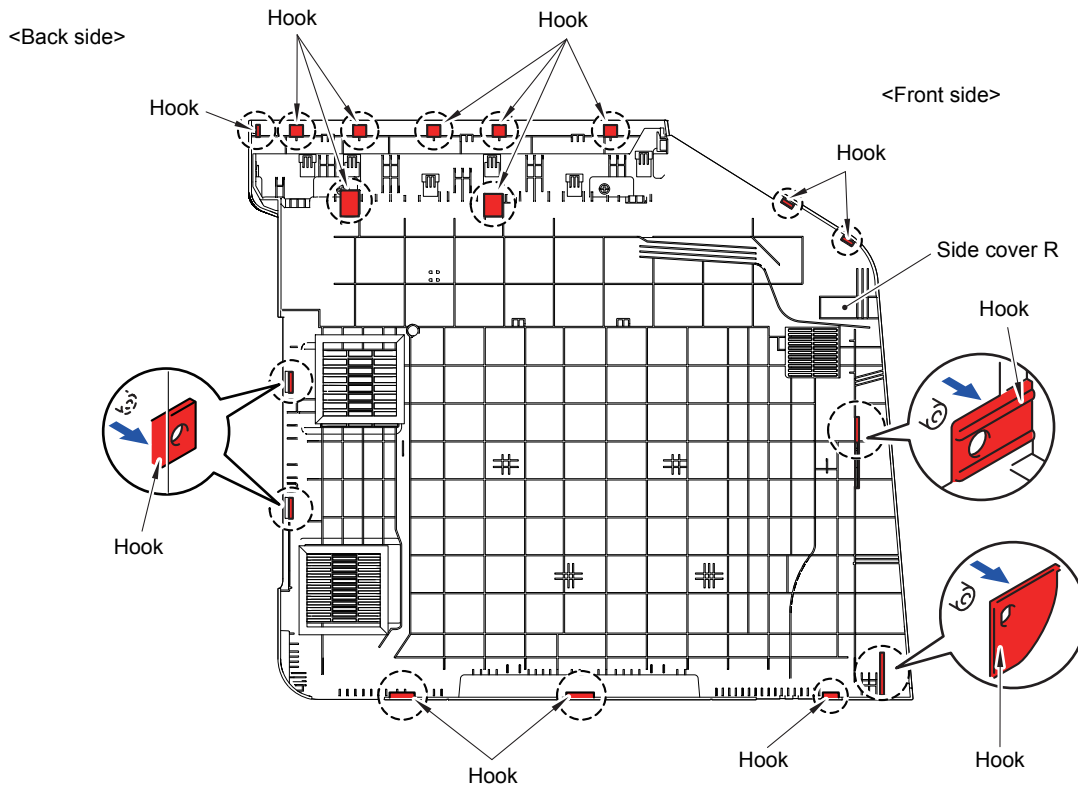

Fig. 7-56

Note:

As the Spacer tends to come off, be careful not to lose it.

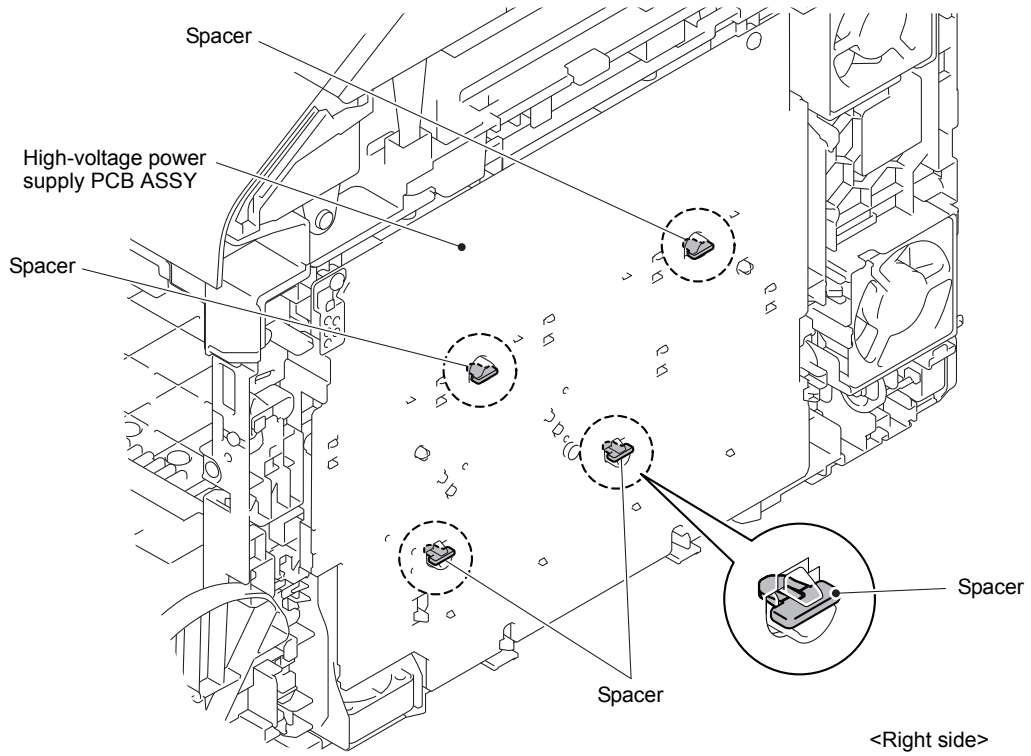

Fig. 7-57

(13) Remove the two Taptite bind B M4x12 screws from the Back cover upper.

(14) Release the four Hooks and remove the Back cover upper from the Main body.

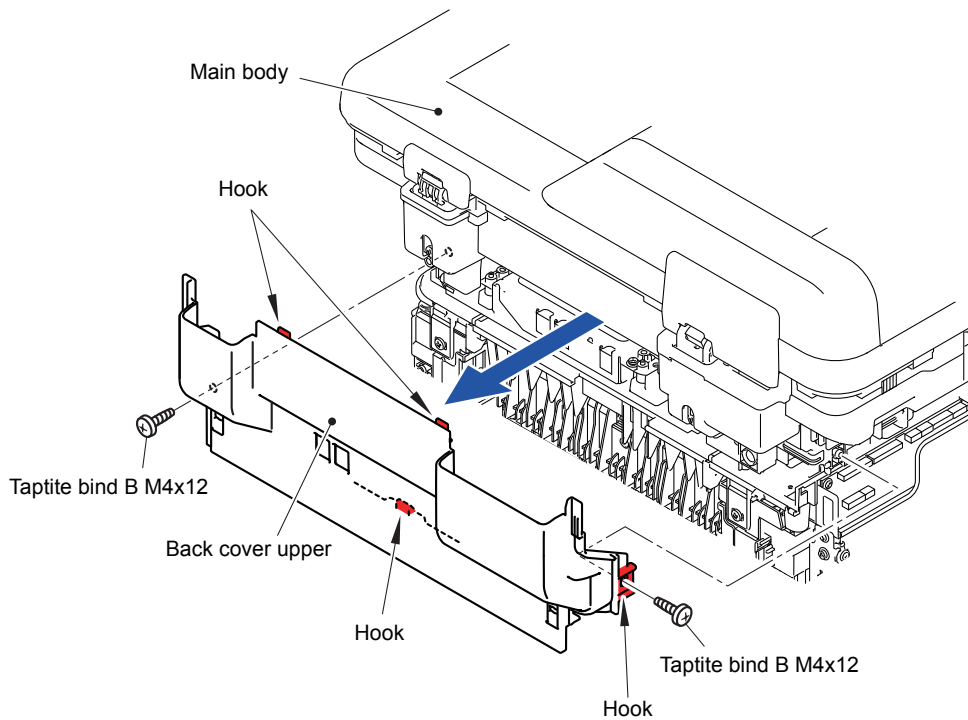

Fig. 7-58

- (15) Remove the Screw bind M3x8 screw and remove the Panel FG harness from the Main shield cover plate ASSY.
- (16) Remove the three Screw bind M3x8 screws and remove the Main shield cover plate ASSY from the Main body.

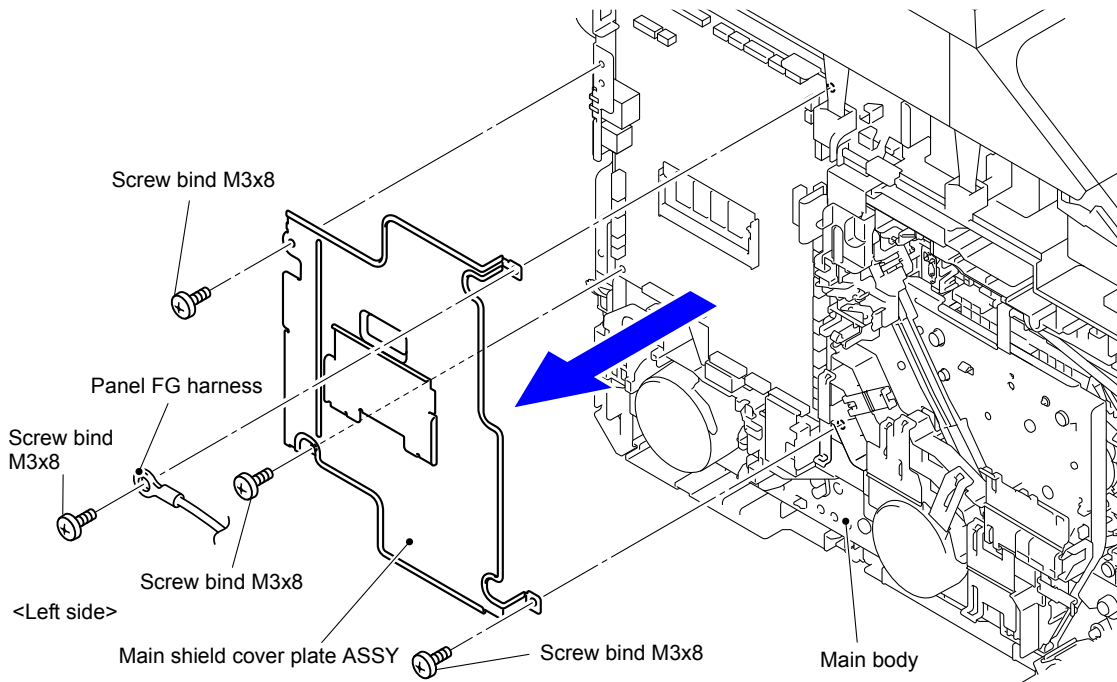

Fig. 7-59

- (17) Remove the two Screw bind M3x8 screws and remove the ADF earth harness and Document scanner FG harness from the Main PCB plate.
- (18) Disconnect the two Connectors (CN39 and CN41) from the Main PCB ASSY and release the wiring of the Main PCB insulation sheet.

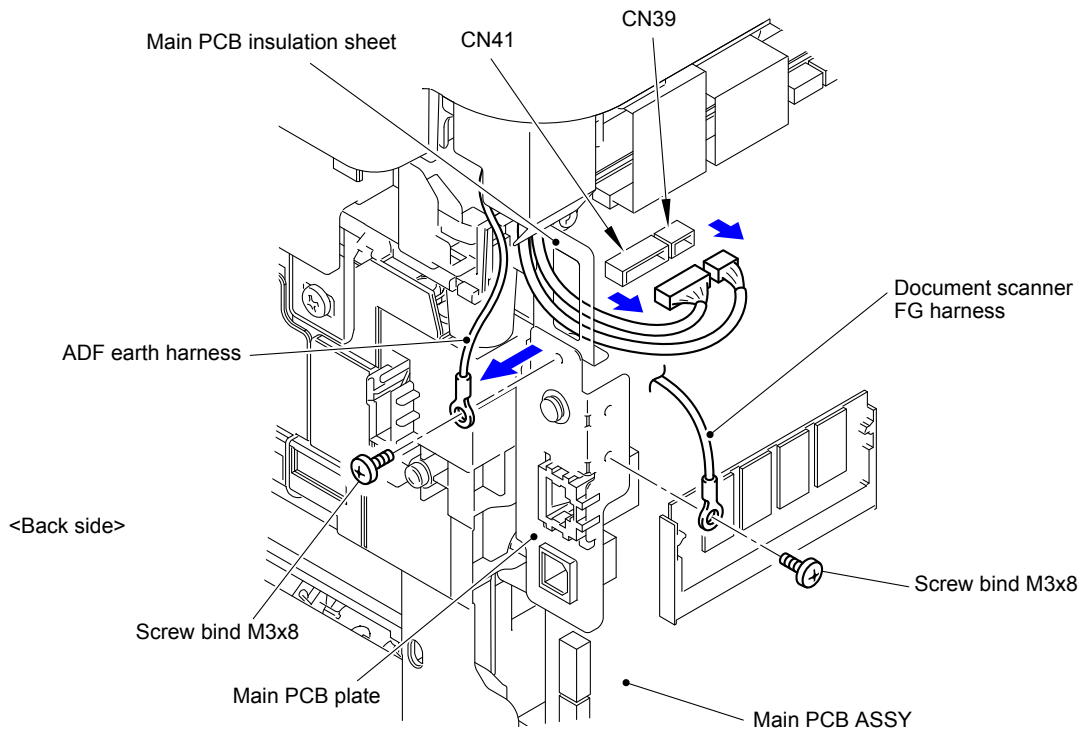

Fig. 7-60

- (19) Disconnect the four Connectors (CN20, CN27, CN32 and CN33) and two Flat cables (CN37 and CN38) from the Main PCB ASSY.

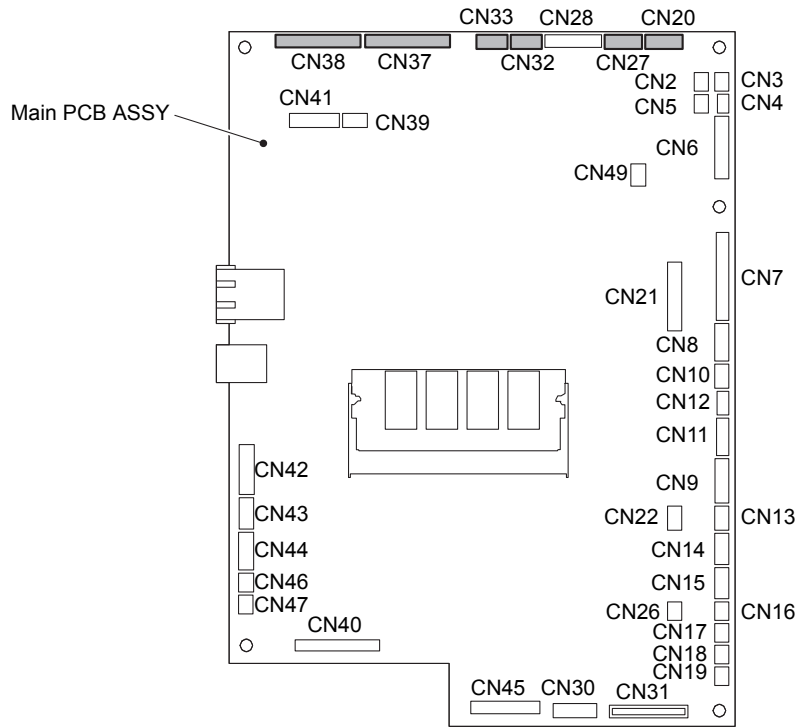

Fig. 7-61

- (20) Release all the wiring from the Document scanner unit.
 (21) Release the Hook and remove the Flat core from the Joint cover top.
 (22) Pull out the Second side CIS flat cable from the Flat core.

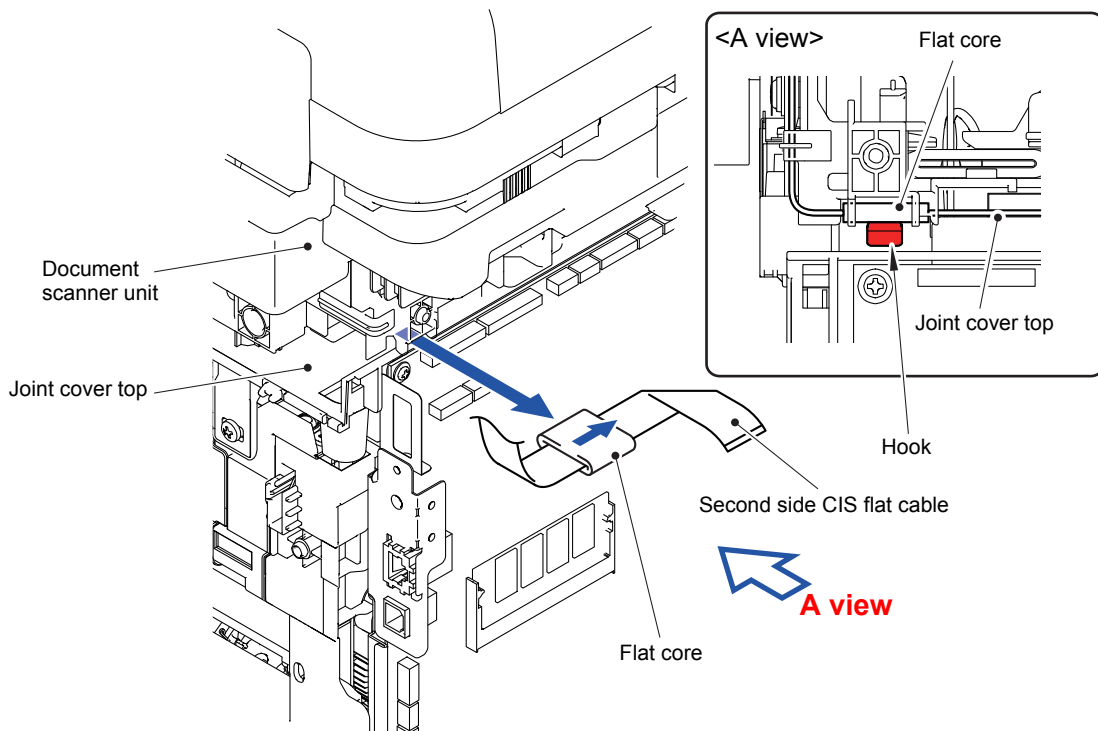

Fig. 7-62

- (23) Remove the two Taptite bind B M4x12 screws from the right side of the Main body.
- (24) Remove the two Taptite bind B M4x12 screws from the left side of the Main body.
- (25) Remove the two Taptite cup B M4x12 screws from the back side of the Main body.

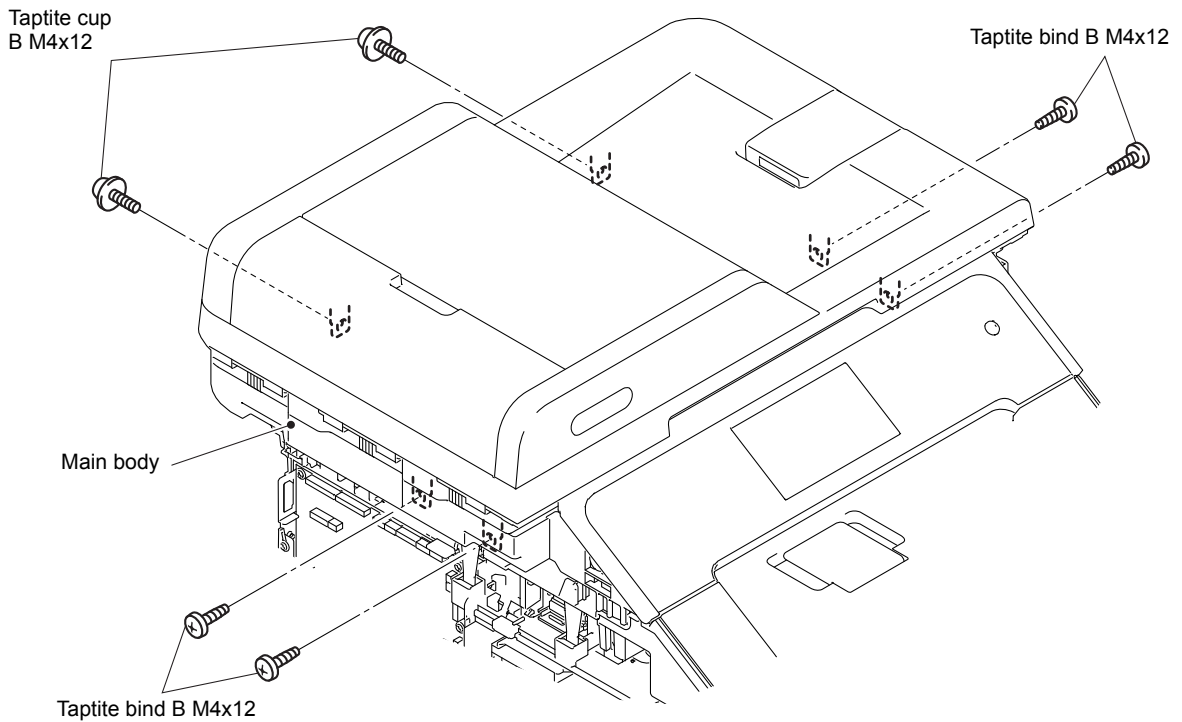

Fig. 7-63

- (26) Remove the eight Hooks and lift the Document scanner unit from the Main body.
- (27) Pull out the First side CIS flat cable from the Flat core of the Main body as lifting the Document scanner unit.

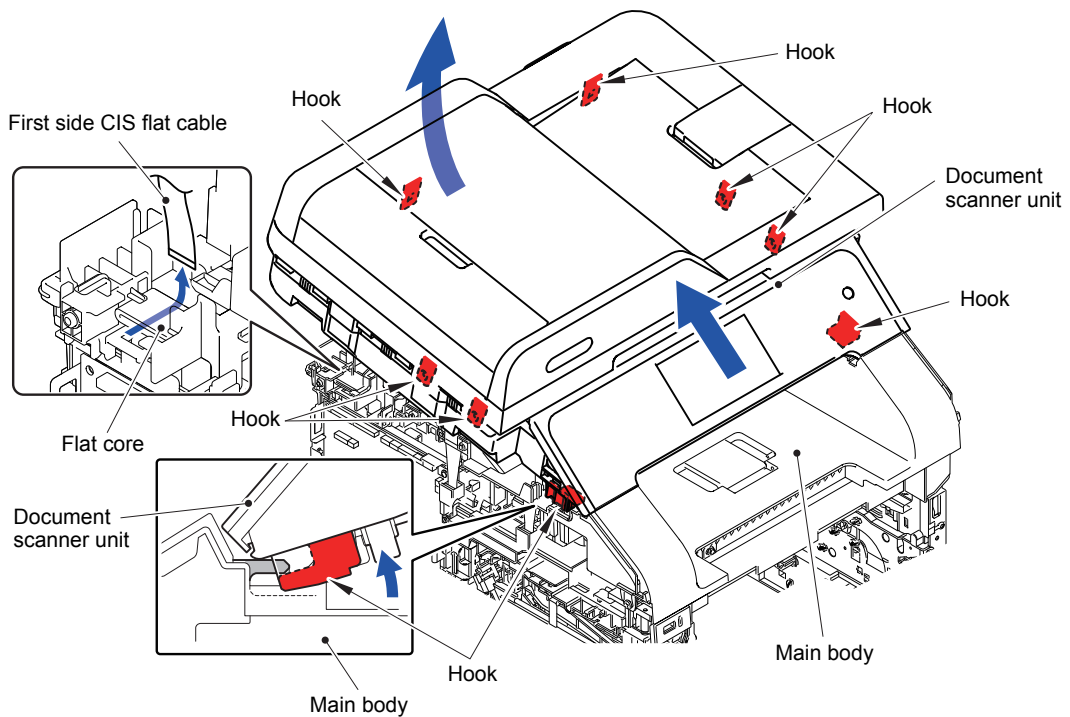

Fig. 7-64

(28) Remove the Screw pan (S/P washer) M3.5x6 screw and remove the Modem FG harness from the Main PCB plate.

(29) Disconnect the Modem flat cable (CN28) from the Main PCB ASSY.

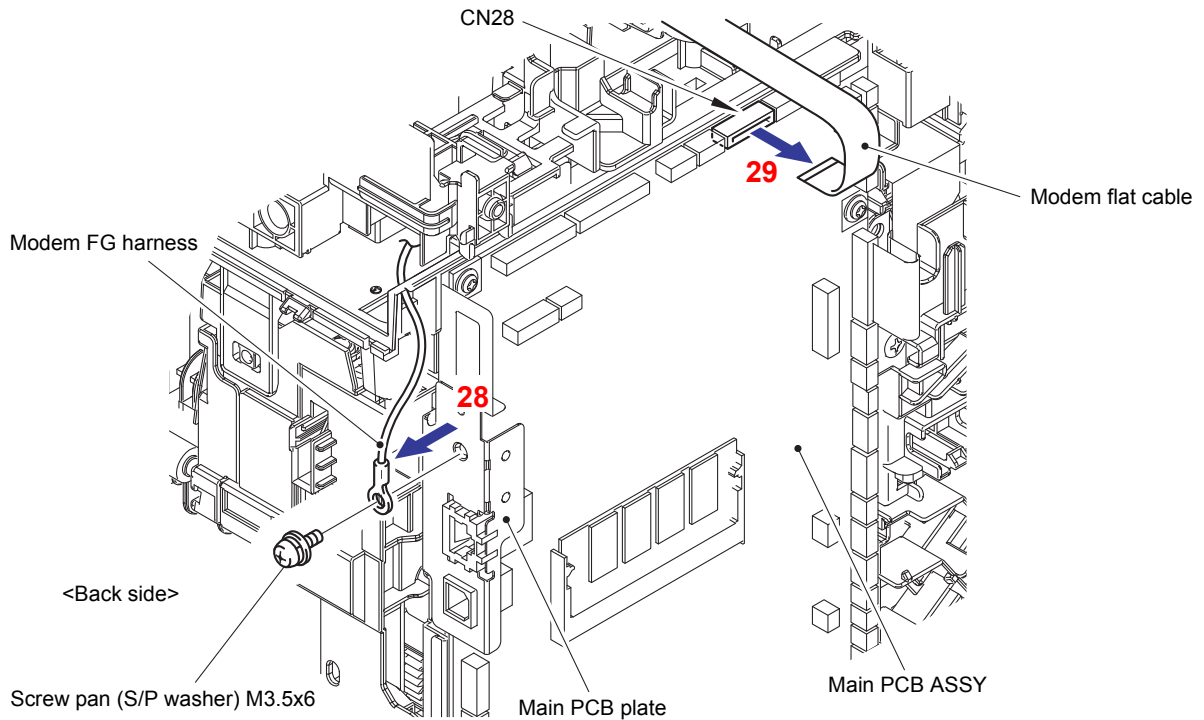

Fig. 7-65

(30) Remove the eight Taptite bind B M4x12 screws from the Joint cover top.

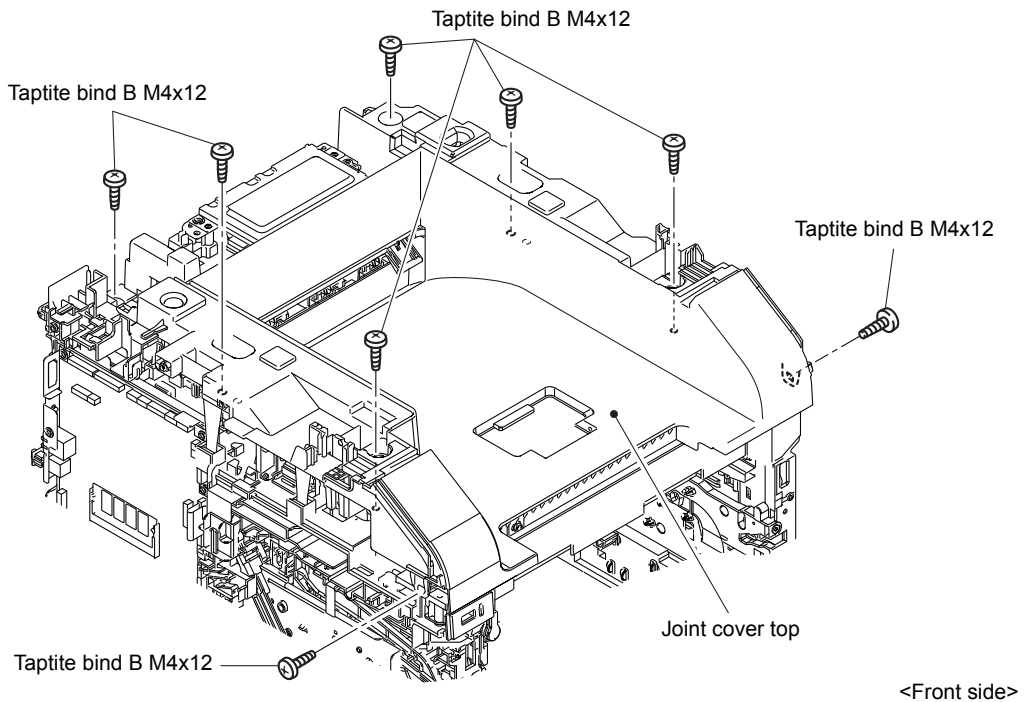

Fig. 7-66

(31) Remove the Screw pan (S/P washer) M3.5x6 screw and remove the Modem ground harness from the High-voltage power supply PCB ASSY.

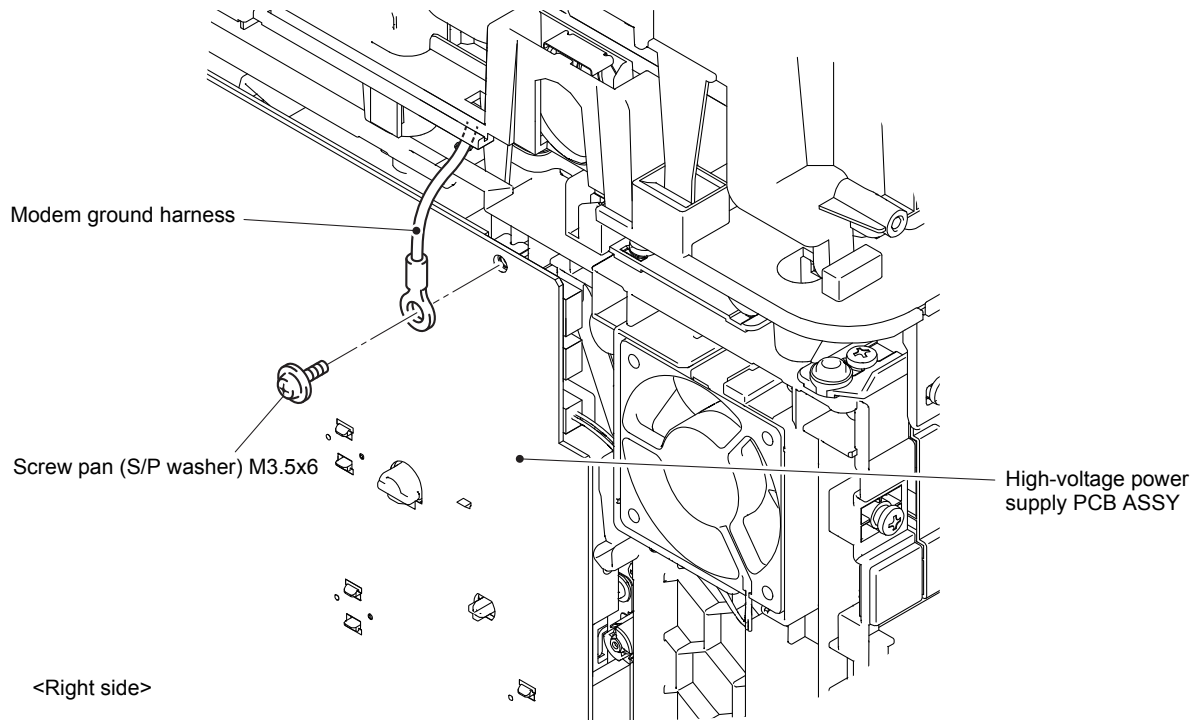

Fig. 7-67

(32) Disconnect the wiring of the Modem ground harness.

(33) Release the two Hooks A and release the two Hooks B.

(34) Release the four Hooks C and lift the Joint cover top in the direction of the arrow.

(35) Slide the Joint cover top from the four Hooks D and remove it from the Main body.

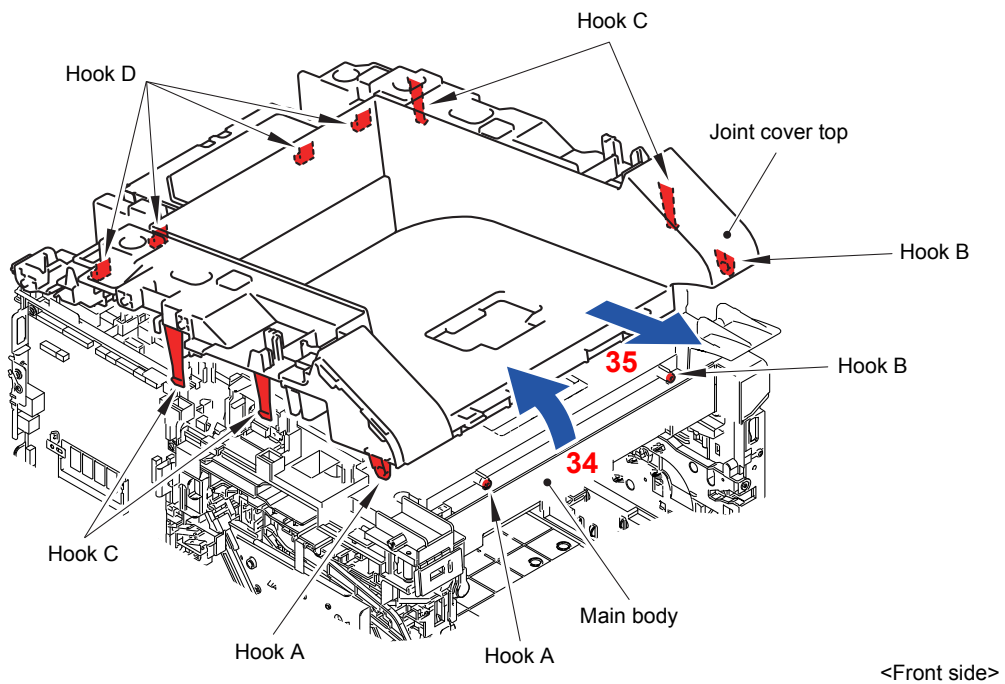

Fig. 7-68

(36) Disconnect the three Connectors (CN4, CN9 and CN11) from the Main PCB ASSY.

(37) Disconnect the wiring of the Main USB host harness ASSY.

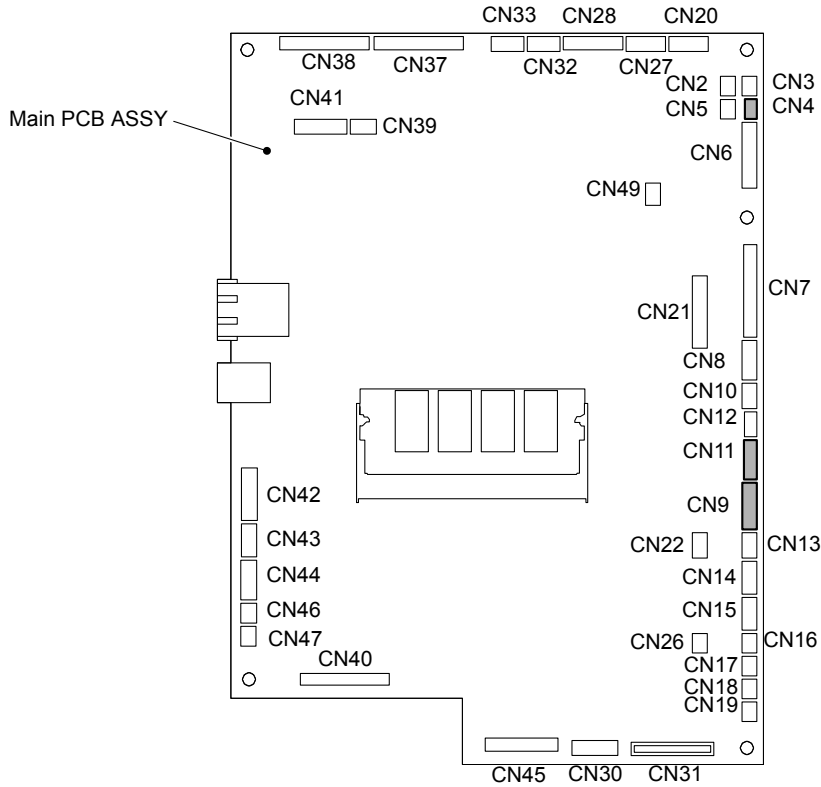

Fig. 7-69

(38) Remove the seven Taptite bind B M4x12 screws from the Joint cover base ASSY.

(39) Remove the two Taptite bind B M4x12 screws from the back of the Joint cover base ASSY.

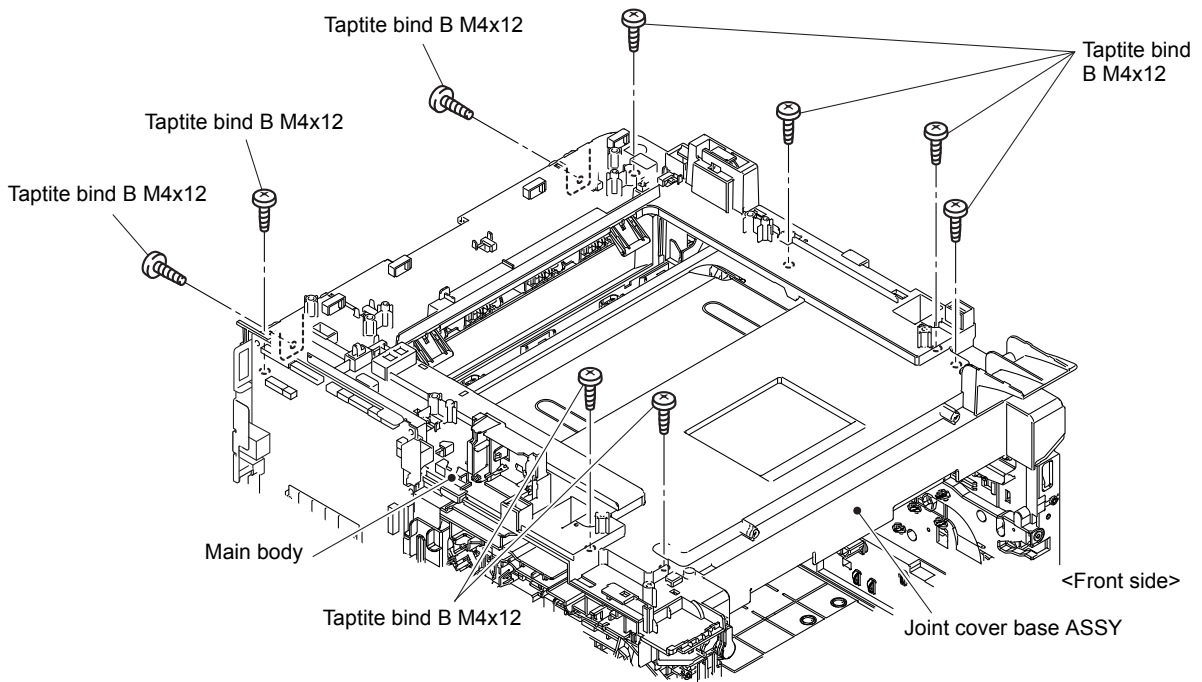

Fig. 7-70

(40) Release the three Hooks 1. Release the other seven Hooks and remove the Joint cover base ASSY from the Main body.

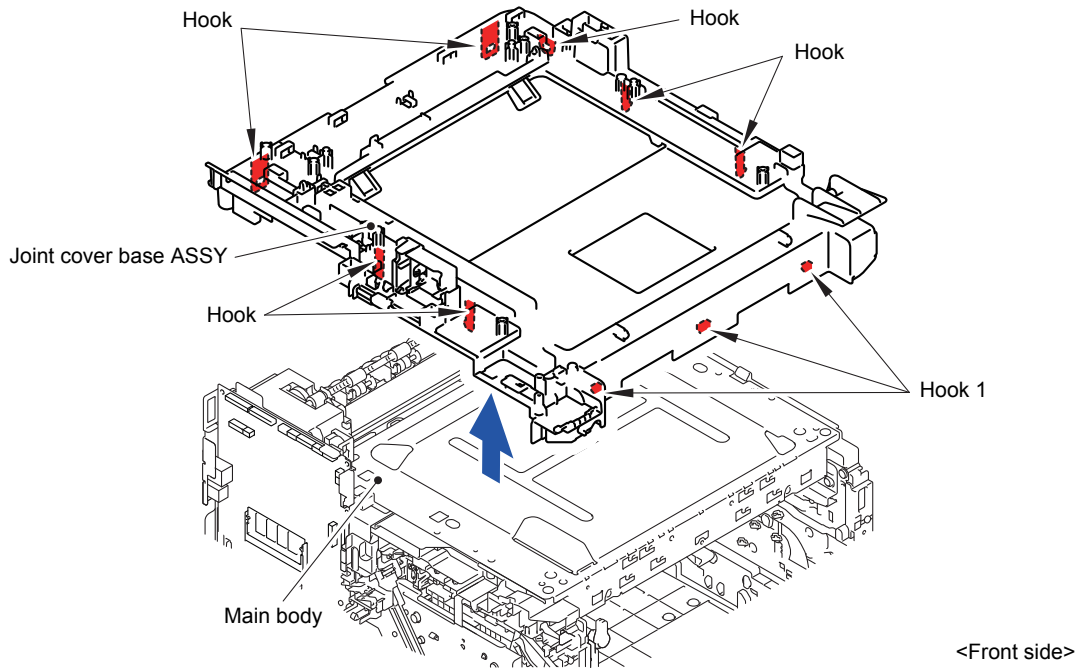

Fig. 7-71

(41) Remove the six Taptite bind B M4x12 screws and four Taptite cup S M3x6 SR screws, and remove the Scanner cover plate from the Main body.

Assembling Note:

When assembling the six screws of the Taptite bind B M4x12, be sure to assemble them in the order shown in the figure.

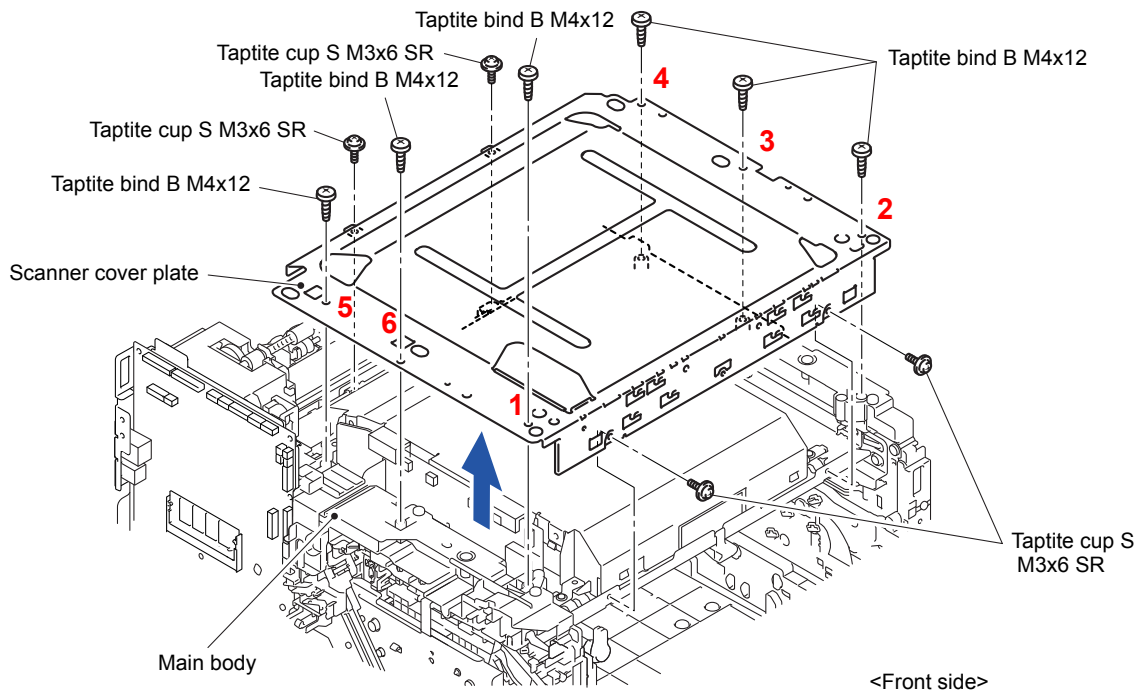

Fig. 7-72

(42) Disconnect the Laser unit flat cable from the Laser unit.

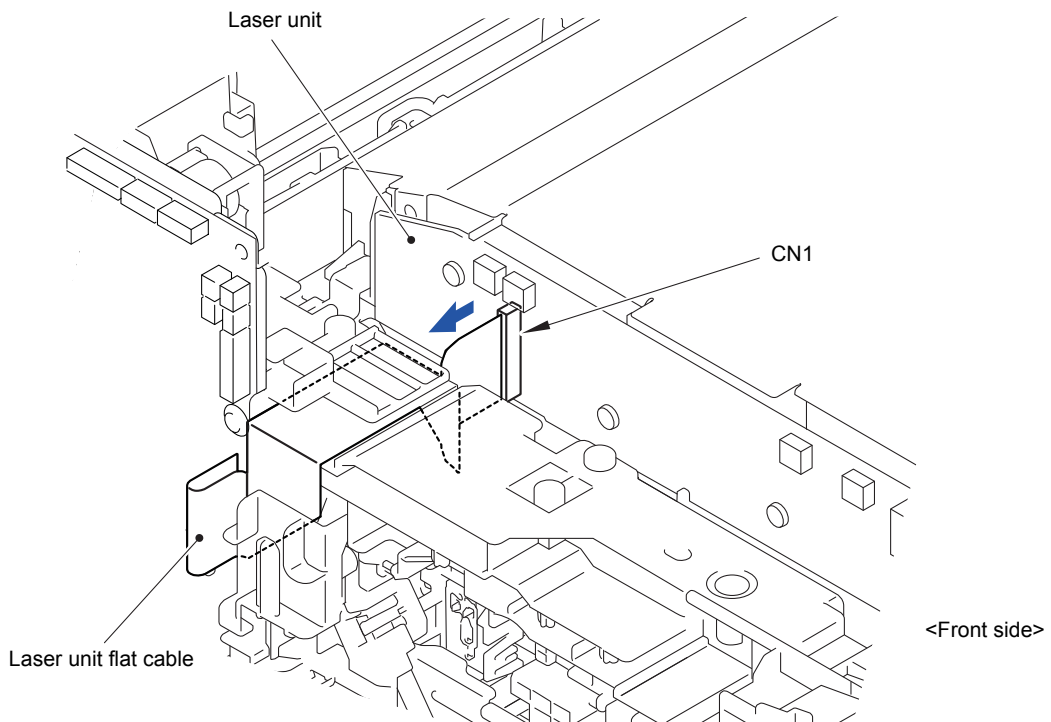

Fig. 7-73

(43) Remove the five Taptite cup S M3x6 SR screws and remove the four Scanner holders from the Scanner plate.

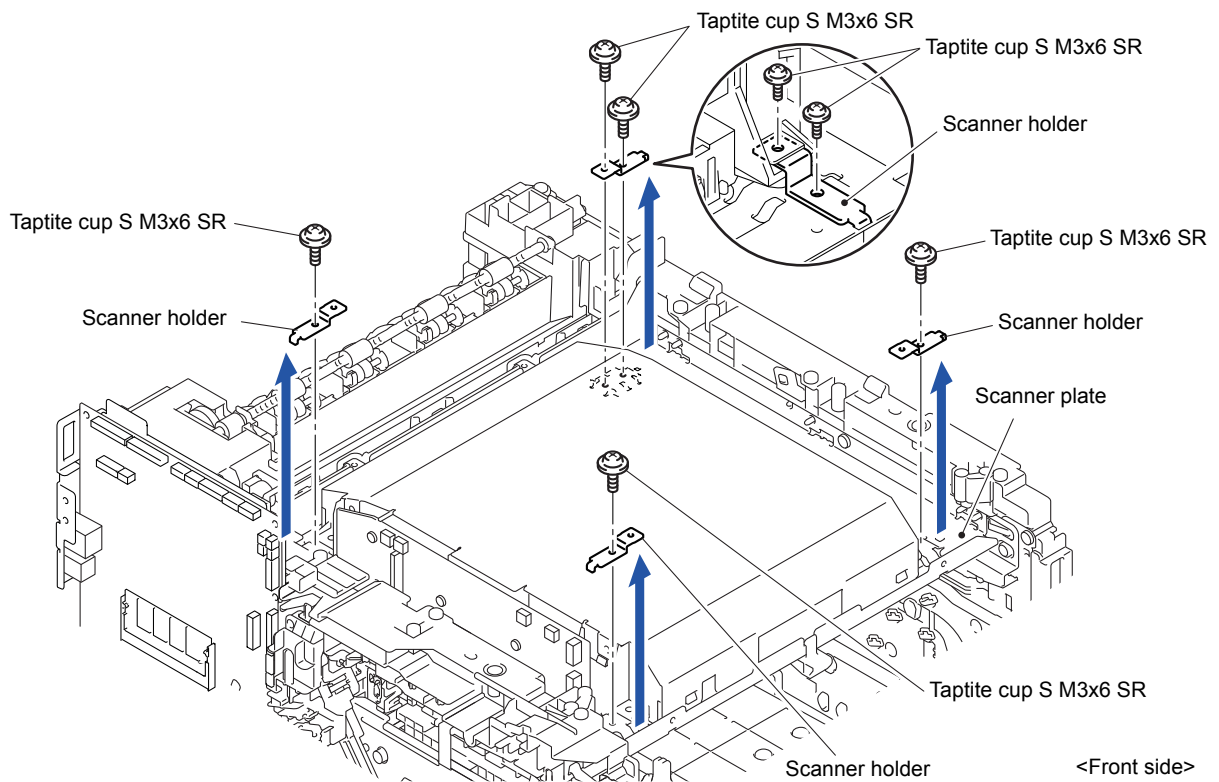

Fig. 7-74

Assembling Note:

- When assembling the Scanner holder to "A" of the Laser unit, be sure to use the Scanner holder of which "B" is a screw and not to use other Scanner holders.
- When assembling the Scanner holder to "A" of the Laser unit, be sure that the Scanner holder is placed as shown in the figure.

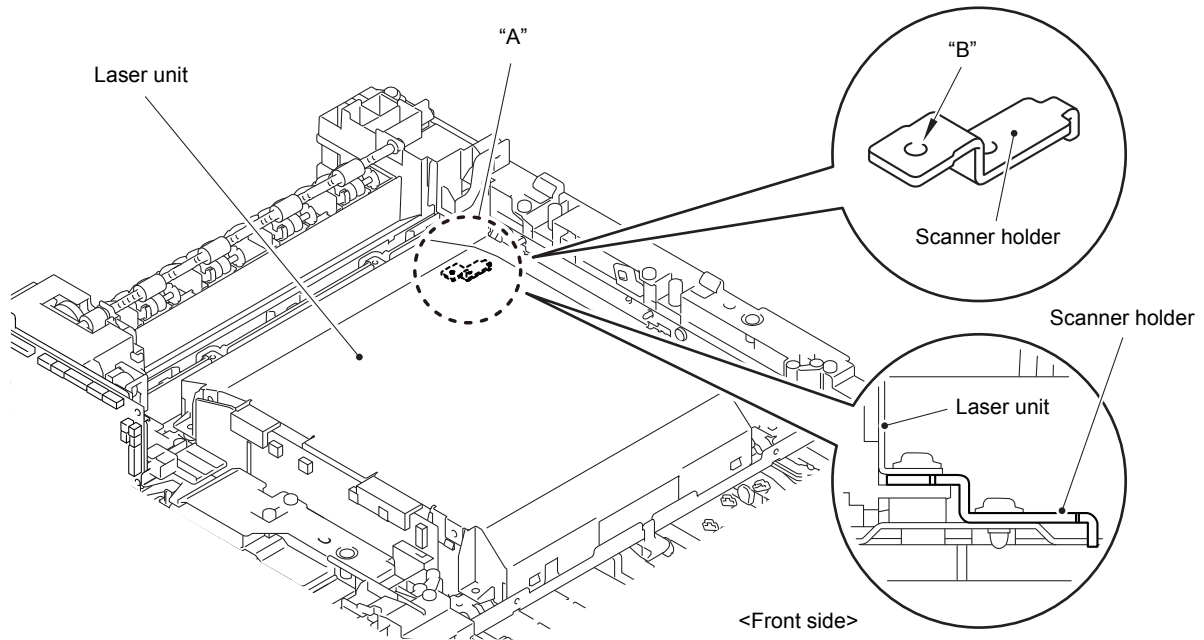

Fig. 7-75

- (44) Disconnect the Connector (CN8).
- (45) Remove the Laser unit from the Scanner plate.

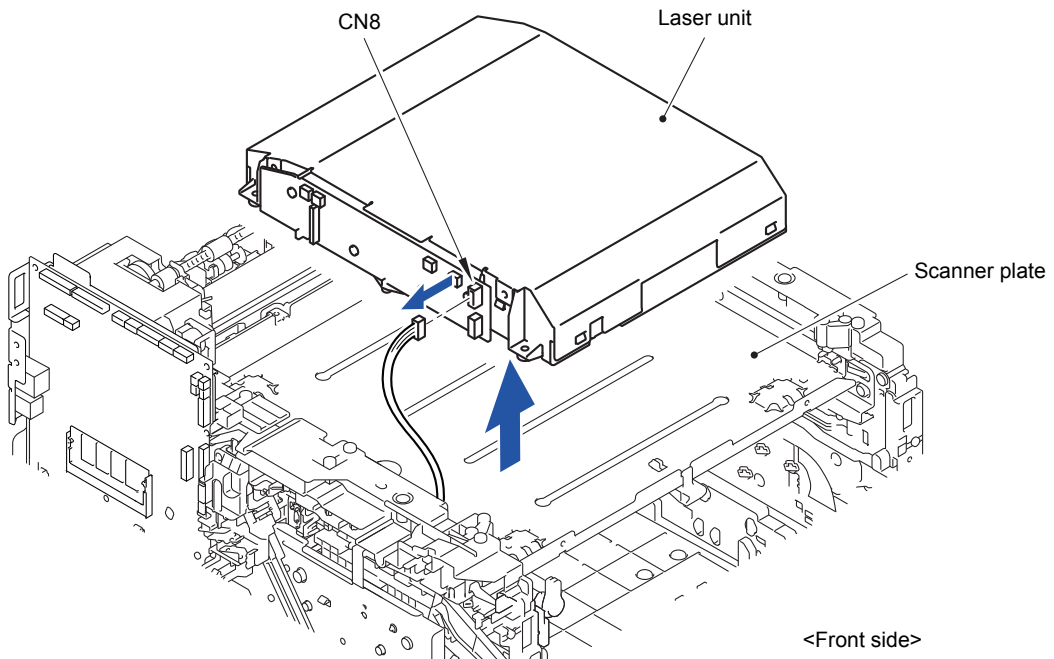

Fig. 7-76

- (46) After replacing the Laser unit, reset the counter. (Refer to ["1.3.37 Reset counters for parts \(Function code 88\)"](#) in Chapter 5.)

2.1.3 PF kit 1

- (1) Release the Hook and remove the Separation pad holder ASSY from the Paper tray 1.

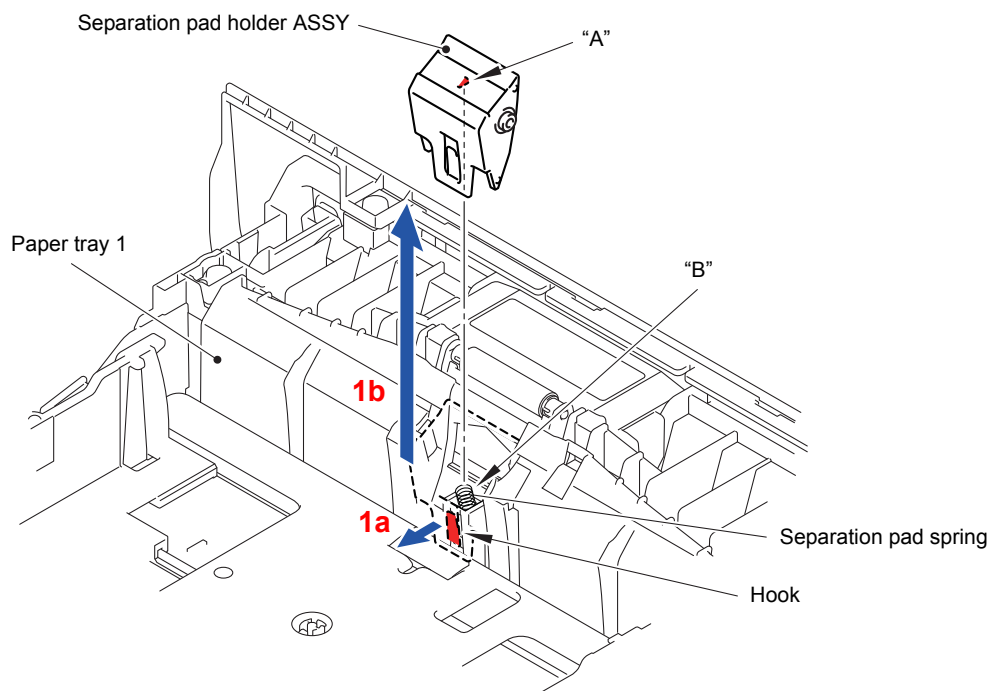

Fig. 7-77

Assembling Note:

When assembling the Separation pad holder ASSY, be sure to assemble it in a way that "A" of the Separation pad holder ASSY is inserted into "B" of the Separation pad spring.

- (2) Remove the Separation pad spring from the Paper tray 1.

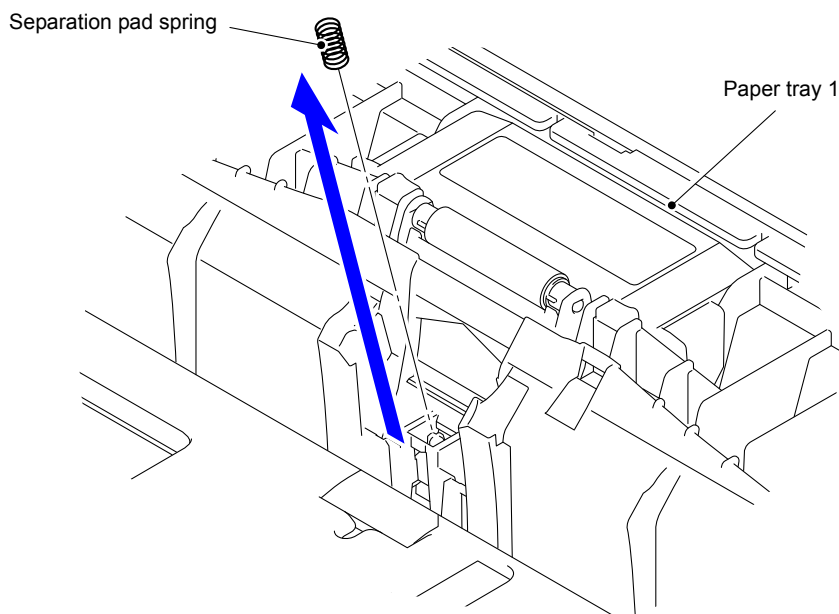

Fig. 7-78

- (3) Push the T1 lift arm to the back and remove "B" of the Roller holder ASSY from "A" of the T1 lift arm.

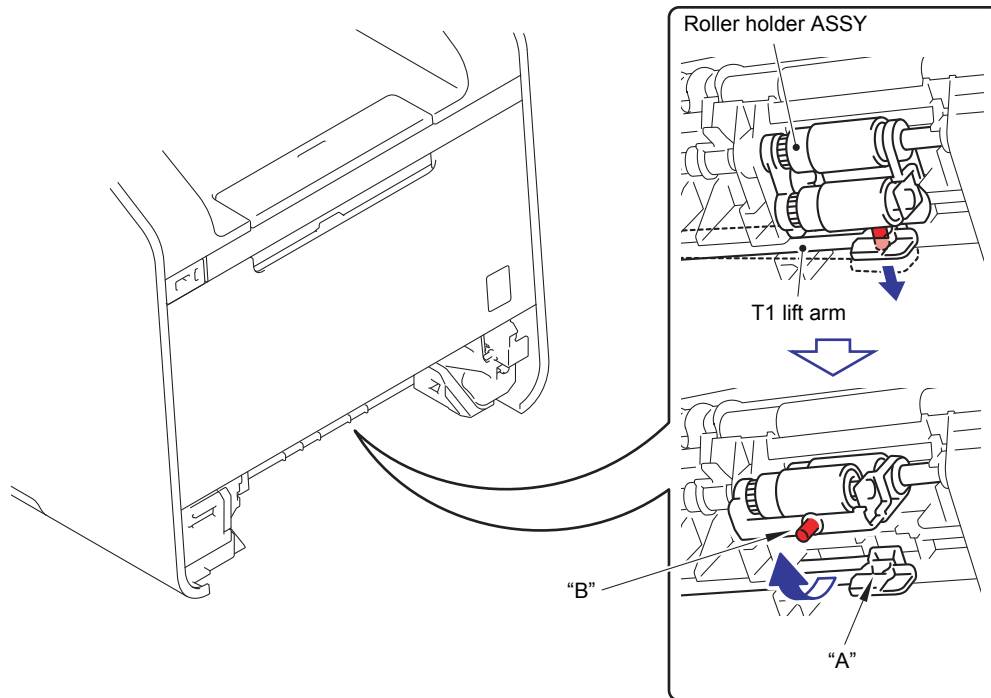

Fig. 7-79

- (4) Slide the Roller holder ASSY in the direction of the arrow and remove it from the T1 drive shaft gear Z17M07.
- (5) Slide the Roller holder ASSY in the direction of the arrow 5a and 5b in this order and remove it from the Paper feed unit.

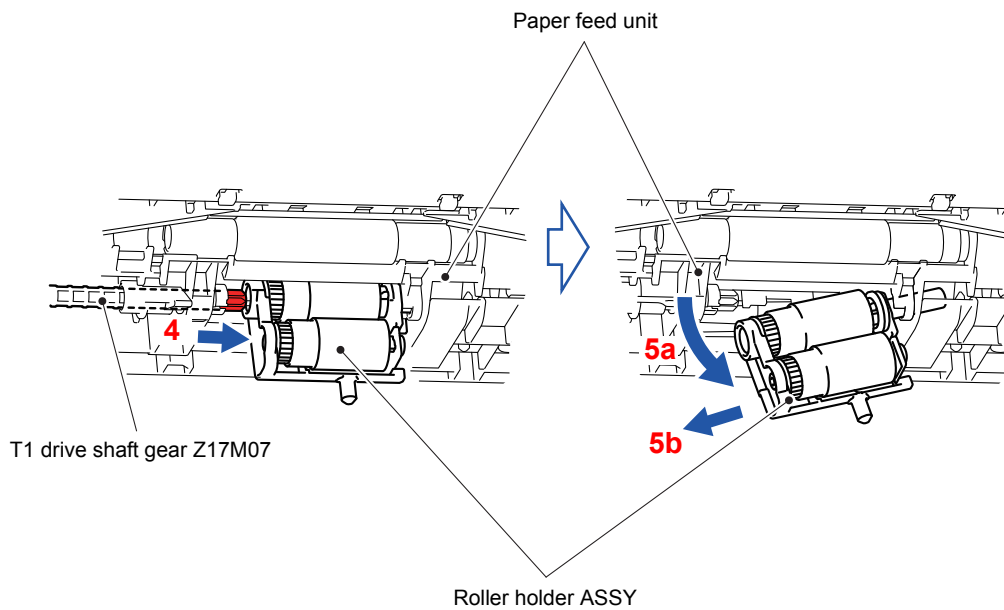

Fig. 7-80

Assembling Note:

Align the Hole of the Paper feed unit to the Shaft of the Roller holder ASSY and insert it into the hole.

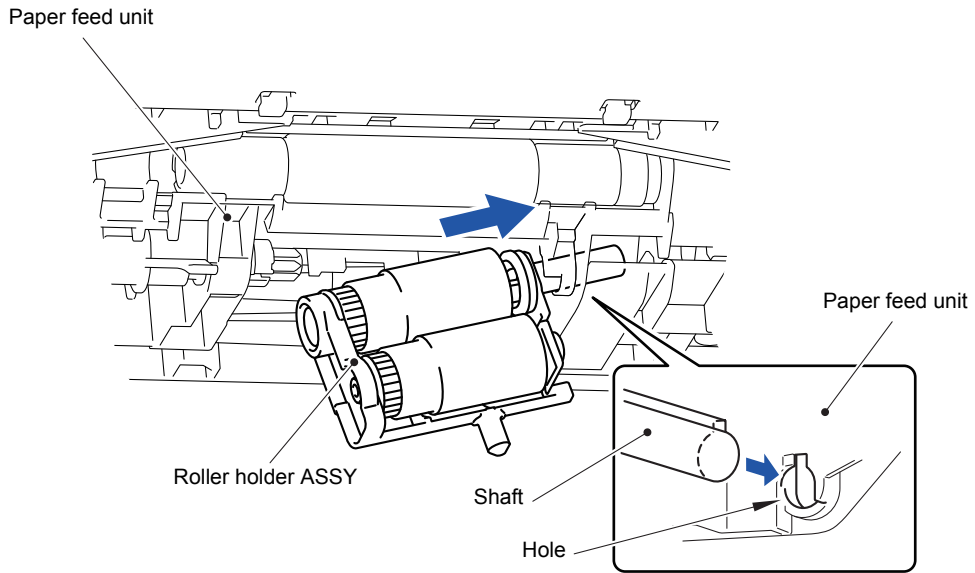

Fig. 7-81

- (6) After replacing the PF kit 1, reset the counter. (Refer to “1.3.37 Reset counters for parts (Function code 88)” in Chapter 5.)

2.1.4 PF kit 2

- (1) Release the two Hooks of the T2 separation pad ASSY to remove them in the upward direction.

Note:

Be careful not to lose the T2 separation pad spring.

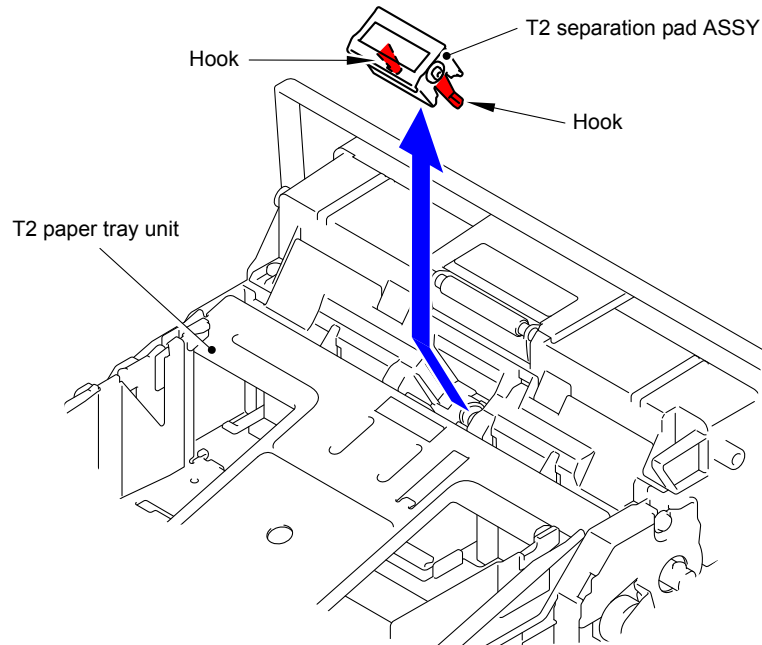

Fig. 7-82

- (2) Remove the T2 separation pad spring from the T2 separation pad ASSY.

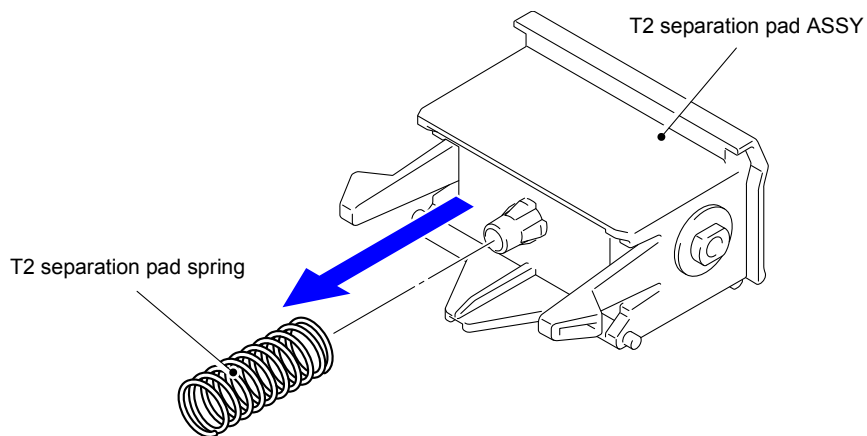

Fig. 7-83

- (3) Release the Hook and slide the T2 separation roller ASSY in the direction of the arrow.
- (4) Rotate the T2 separation roller ASSY in the direction of the arrow 4a. Remove the T2 separation roller ASSY from the T2 paper feed drive shaft in the direction of the arrow 4b.

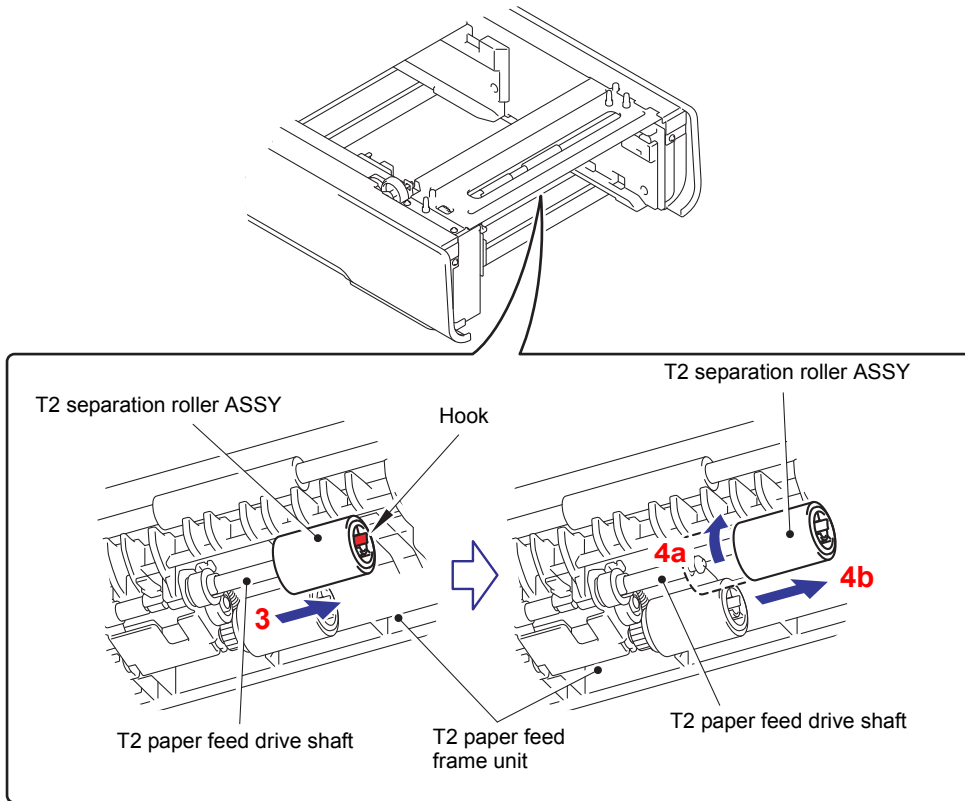

Fig. 7-84

Assembling Note:

When assembling the T2 separation roller ASSY, assemble it by sliding it in the direction of the arrow b as rotating the T2 separation roller ASSY in the direction of the arrow a.

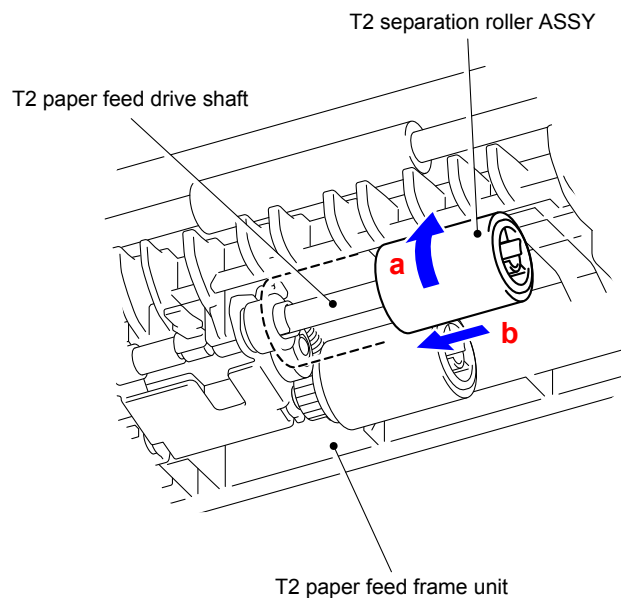

Fig. 7-85

- (5) Release the Hook and remove the T2 paper pick-up roller ASSY from the T2 paper feed drive shaft.

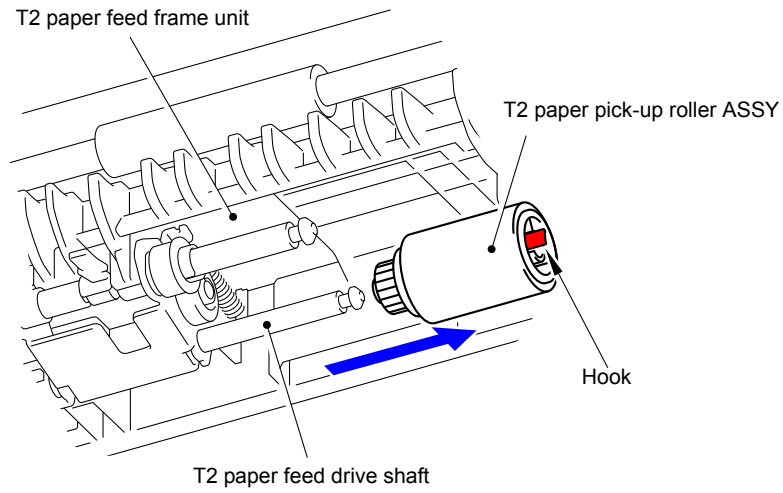

Fig. 7-86

- (6) After replacing the PF kit 2, reset the counter. (Refer to “1.3.37 Reset counters for parts (Function code 88)” in Chapter 5.)

2.1.5 PF kit MP

- (1) Press "A" to release the Hook and remove the MP upper frame cover from the MP upper cover ASSY.

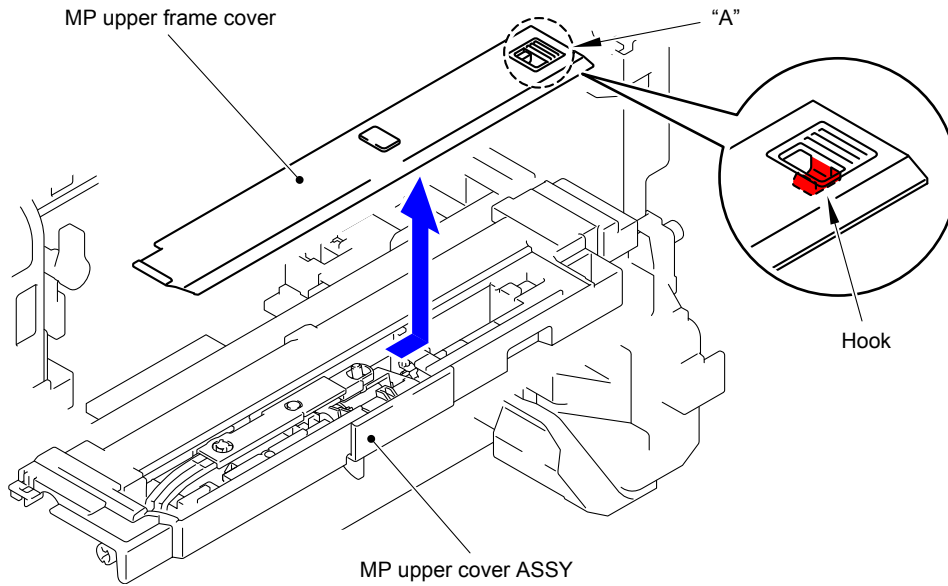

Fig. 7-87

- (2) Remove the MP lift arm B from the MP upper cover ASSY.

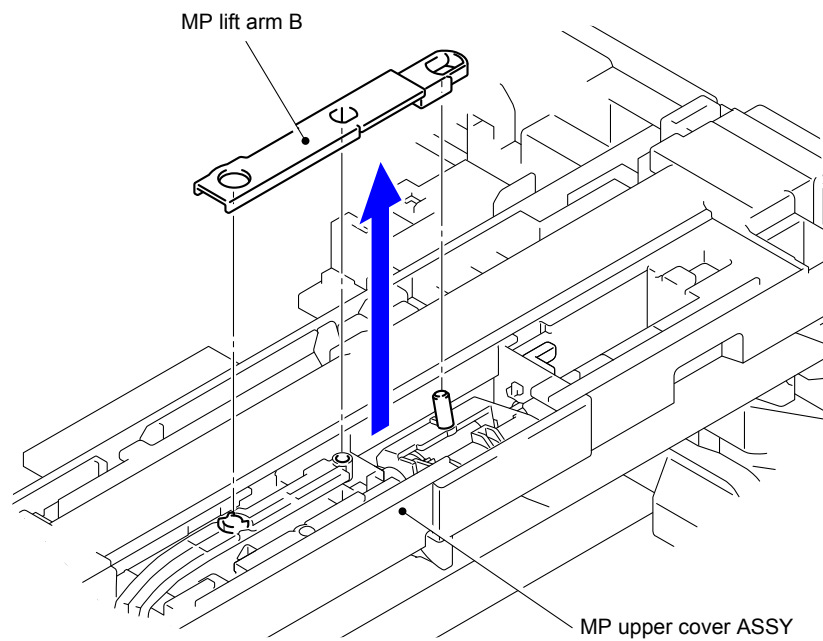

Fig. 7-88

- (3) Release the Hook 1 and rotate the MP holder bushing in the direction of the arrow.
- (4) Release the Hook 2 and remove the MP holder bushing from the MP upper cover ASSY.

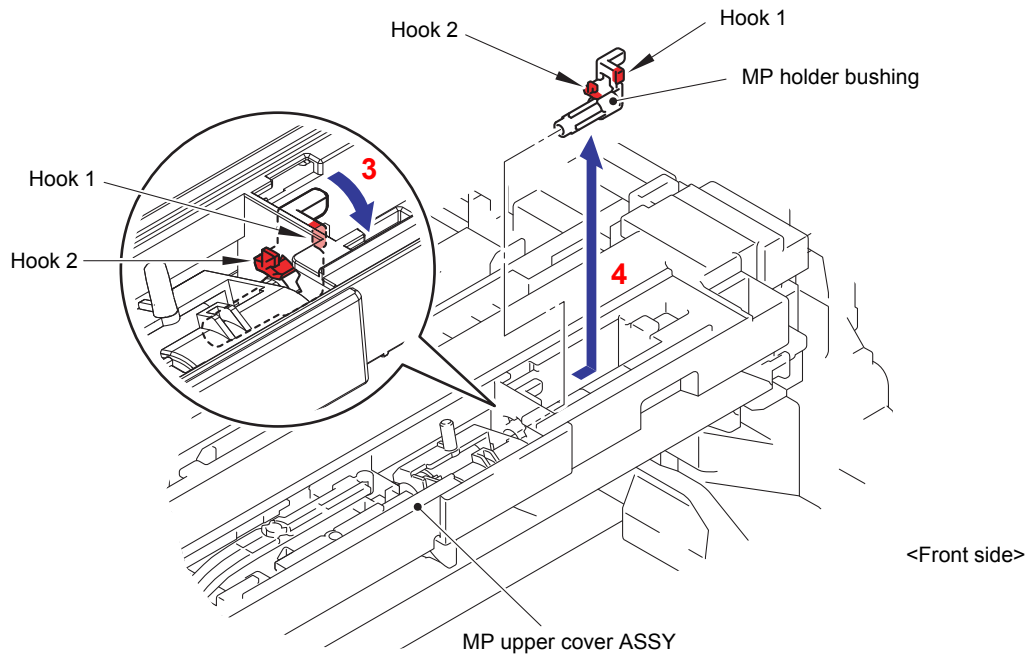

Fig. 7-89

- (5) Remove the MP roller holder ASSY from the MP upper cover ASSY.

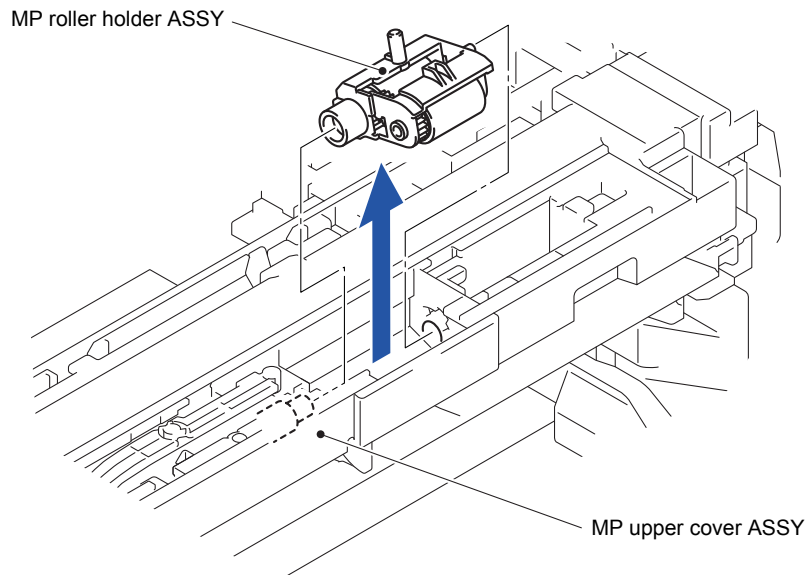

Fig. 7-90

- (6) Turn the MP separation pad ASSY upright to remove it from the MP upper cover ASSY.

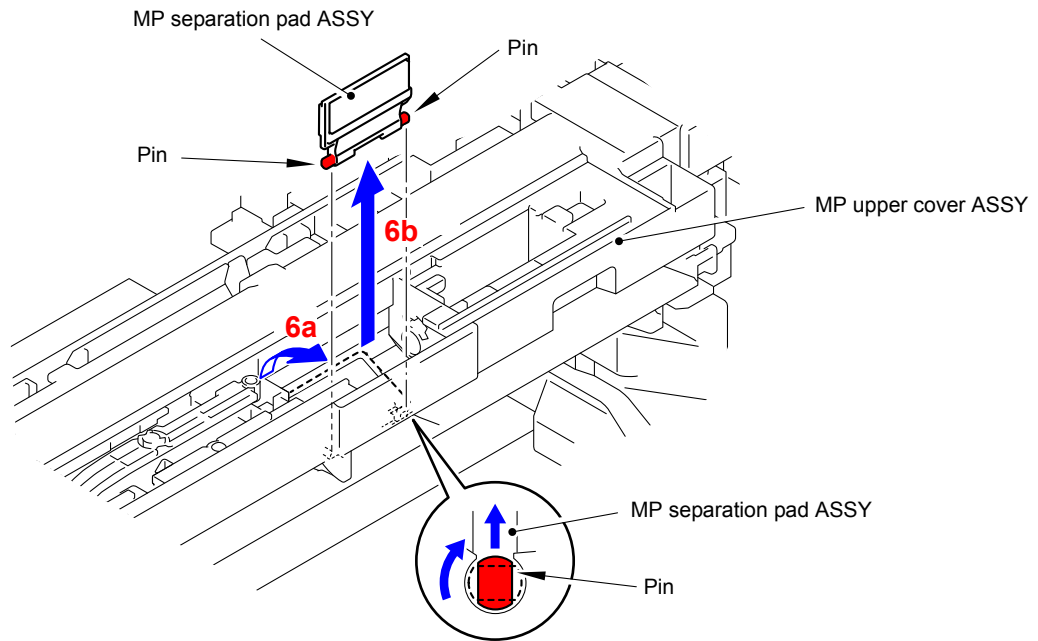

Fig. 7-91

- (7) Remove the MP separation pad spring from the two Pins of MP upper cover ASSY.

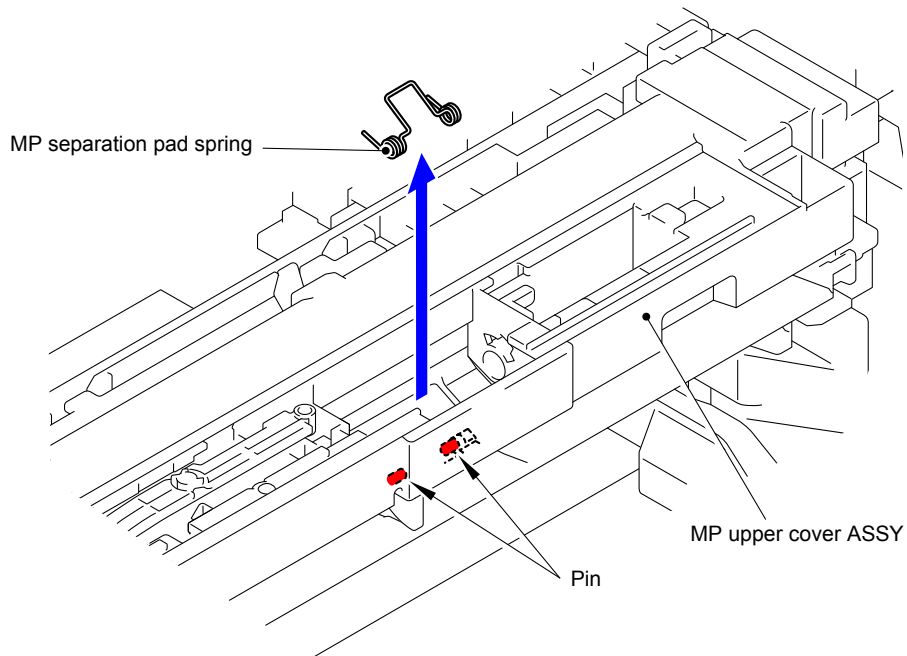

Fig. 7-92

- (8) After replacing the PF kit MP, reset the counter. (Refer to ["1.3.37 Reset counters for parts \(Function code 88\)"](#) in Chapter 5.)

APPENDIX 1 SERIAL NUMBERING SYSTEM

■ Serial number labels for the printer itself

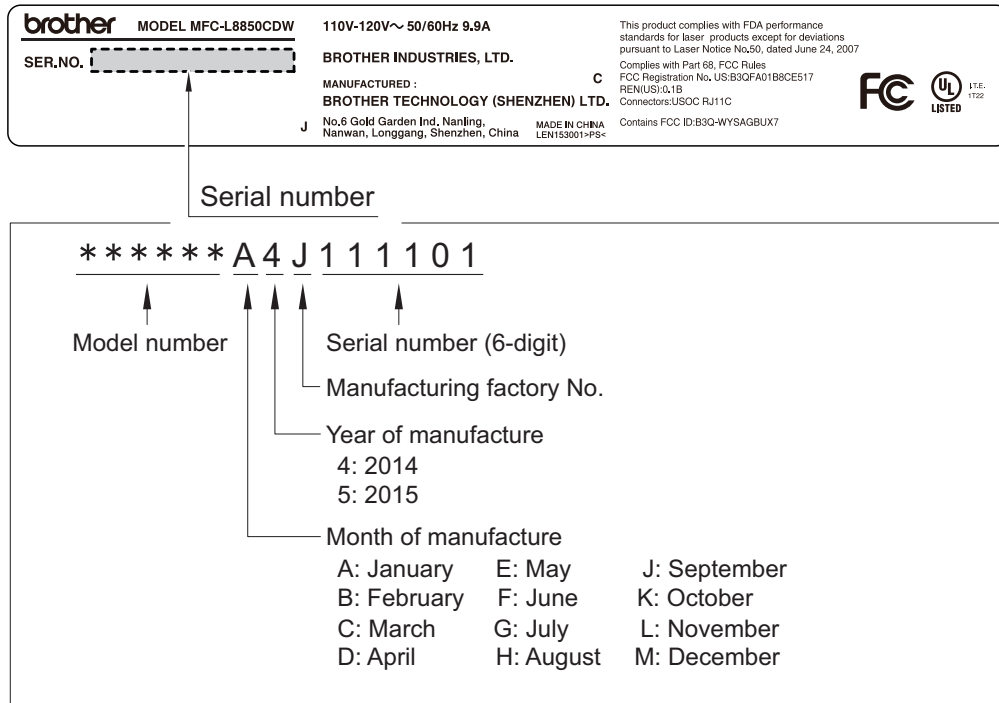

Fig. App 1-1

<Location>

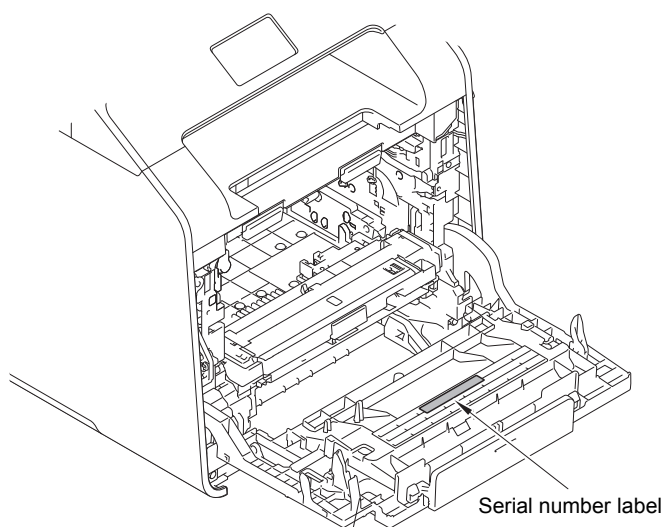

Fig. App 1-2

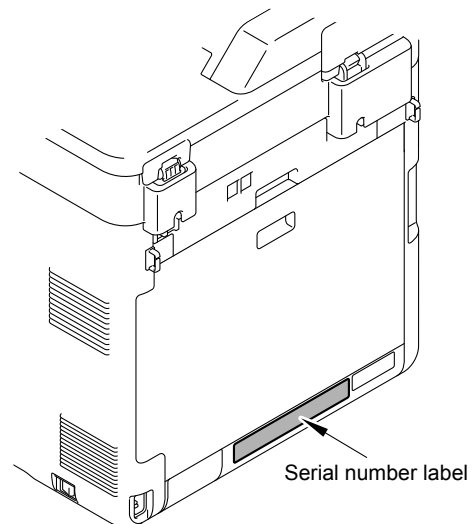



Fig. App 1-3

APPENDIX 2 DELETION OF USER SETTING INFORMATION

In this machine, the user setting information is stored in the main PCB. The following procedure allows the factory default settings to be restored in the machine.

<Operating procedure>

- (1) Press the  (Settings) key on the LCD in the ready state.
- (2) Press the **All Settings** key on the LCD.
- (3) Press the **Initial Setup** key on the LCD.
- (4) Press the **Reset** key on the LCD.
- (5) Press the **Factory Reset** key on the LCD.
- (6) When “Factory Reset? It may take time until reset finishes. Yes No” is displayed on the LCD, press the **Yes** key.
- (7) When “Reboot OK? Press [Yes] for 2 seconds to confirm.” is displayed on the LCD, hold down the **Yes** key for 2 seconds or more. Then, the user settings are cleared, and the machine returns to the ready state.

APPENDIX 3 INSTALLING THE MAINTENANCE PRINTER DRIVER

To identify machines connected via USB direct interface, the computer requires the corresponding driver for the virtual USB device. If you connect any number of machines to your computer, the same number of virtual USB devices will be automatically configured on your computer. To prevent many virtual USB devices from being configured, use the unique driver installation procedure described below that enables your computer to identify terminals via one single virtual USB device.

Note:

- Once this installation procedure is carried out for a computer, no more driver/software installation will be required for that computer to identify machines. If the Brother Maintenance USB Printer driver has been already installed to your computer according to this procedure, skip this section.
- Before proceeding to the procedure given below, make sure that the Brother Maintenance USB Printer driver is stored in your computer.

■ Windows XP

- (1) Check that the power switch of the machine is turned OFF. Disconnect the USB cable that connects the machine with your computer.
- (2) Turn ON your computer.
- (3) Turn ON the power switch of the machine.
- (4) Enter the maintenance mode.
(Refer to “1.1 How to Enter the Maintenance Mode” in Chapter 5.)
- (5) Connect the machine to your computer using a USB cable.
The following window appears.

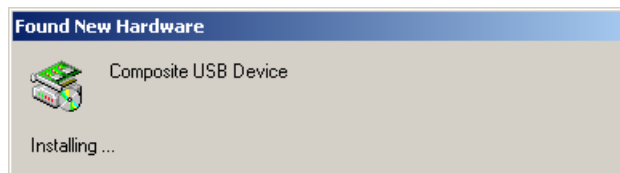

- (6) The following screen appears, indicating the detection of new hardware device by the system. Select “No, not this time.” And click [Next].



(7) Select "Install the software automatically (Recommended)" and click [Next].

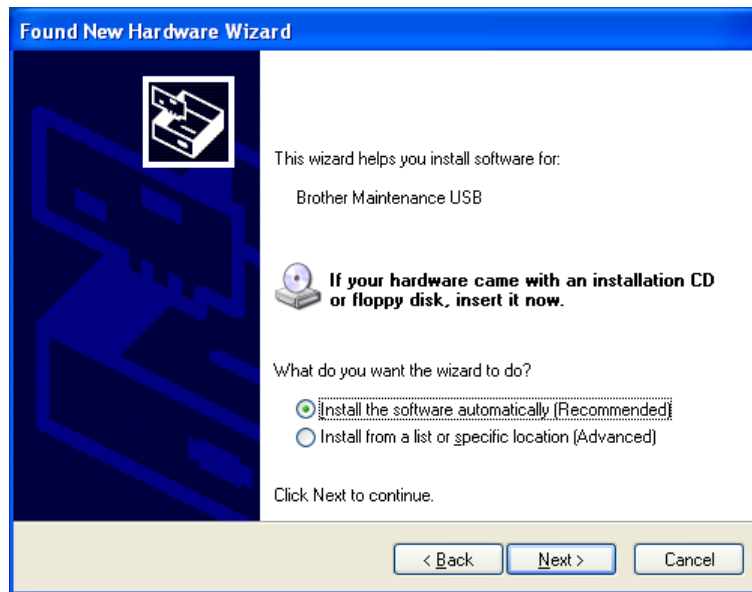

(8) Alert warning message of WHQL appears. Click [Continue Anyway] to proceed.



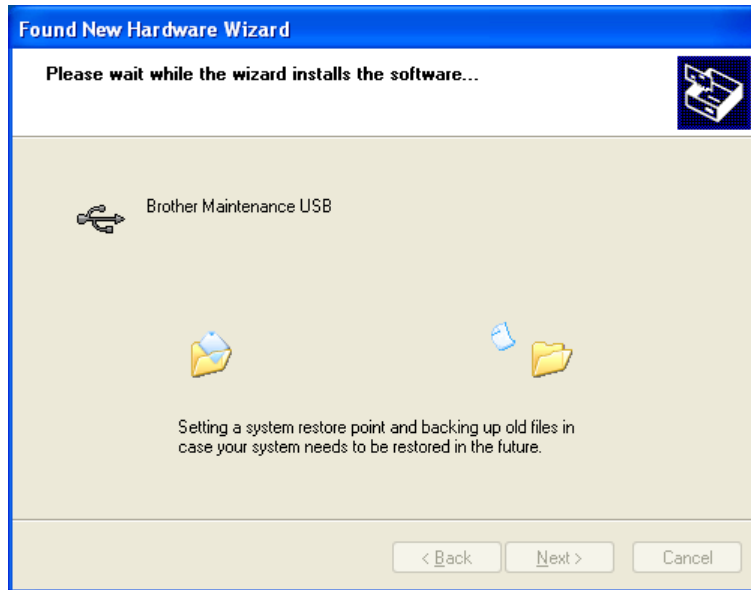

(9) Repeat steps (6) to (8) three times. Installation is completed.

(10) If the Brother Maintenance USB Printer driver is successfully installed, the following message screen appears. Click [Finish] to return.



Note:

In order to check whether the printer driver is successfully installed, click [Start], [Settings], [Printers] to select the Printers window. Then, check that the Brother Maintenance USB Printer icon is shown.

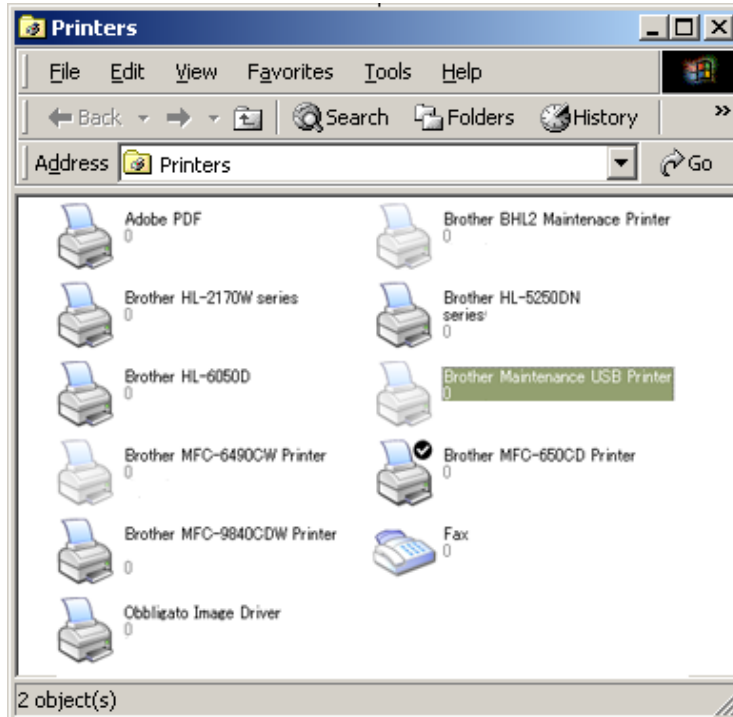

■ **Windows Vista/Windows 7/Windows 8/Windows 8.1**

- (1) Check that the power cord of the machine is unplugged from the electrical outlet. Disconnect the USB cable that connects the machine with your computer.
- (2) Turn ON your computer.
- (3) Double-click Setup.exe inside the Brother Maintenance USB Printer folder that was saved in a temporary folder. The following screen appears. Click the [Next] button.



The following screen is displayed during installation.

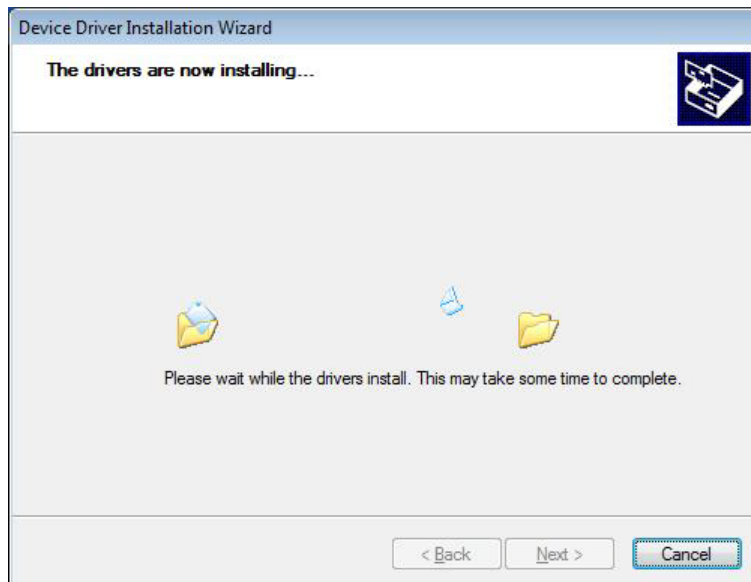

- (4) Wait for the following screen to appear and click [Finish].



- (5) Plug the power cord of the machine into an electrical outlet.
- (6) Enter the maintenance mode.
(Refer to "1.1 How to Enter the Maintenance Mode" in Chapter 5.)
- (7) Connect the machine to your computer using a USB cable and the installation will be performed automatically.