



**FACSIMILE EQUIPMENT
SERVICE MANUAL**

**MODEL: FAX2800/FAX2900/FAX3800
MFC4800**

FAX8070P/MFC9030/MFC9070

© Copyright Brother 2001

All rights reserved.

No part of this publication may be reproduced in any form or by any means without permission in writing from the publisher.

Specifications are subject to change without notice.

PREFACE

This publication is a Service Manual covering the specifications, construction, theory of operation, and maintenance of the Brother facsimile equipment. It includes information required for field troubleshooting and repair--disassembly, reassembly, and lubrication--so that service personnel will be able to understand equipment function, to rapidly repair the equipment and order any necessary spare parts.

To perform appropriate maintenance so that the facsimile equipment is always in best condition for the customer, the service personnel must adequately understand and apply this manual.

This manual is made up of six chapters and appendices.

CHAPTER 1 GENERAL DESCRIPTION

CHAPTER 2 INSTALLATION

CHAPTER 3 THEORY OF OPERATION

CHAPTER 4 DISASSEMBLY/REASSEMBLY AND LUBRICATION

CHAPTER 5 MAINTENANCE MODE

CHAPTER 6 ERROR INDICATION AND TROUBLESHOOTING

Appendix 1. EEPROM Customizing Codes

Appendix 2. Firmware Switches (WSW)

Appendix 3. Circuit Diagrams

This manual describes the models and their versions to be destined for major countries. The specifications and functions are subject to change depending upon each destination.

SAFETY INFORMATION

Laser Safety (110-120V Model only)

This printer is certified as a Class 1 laser product under the US Department of Health and Human Services (DHHS) Radiation Performance Standard according to the Radiation Control for Health and Safety Act of 1968. This means that the printer does not produce hazardous laser radiation.

Since radiation emitted inside the printer is completely confined within the protective housings and external covers, the laser beam cannot escape from the machine during any phase of user operation.

CDRH Regulations (110-120V Model only)

The Center for Device and Radiological Health (CDRH) of the US Food and Drug Administration implemented regulations for laser products on August 2, 1976. These regulations apply to laser products manufactured from August 1, 1976. Compliance is mandatory for products marketed in the United States. The label shown below indicates compliance with the CDRH regulations and must be attached to laser products marketed in the United States.

The label for Chinese products

MANUFACTURED: JUNE 2001 C
BROTHER CORP. (ASIA) LTD.
BROTHER BUJI NAN LING FACTORY
Gold Garden Industry, Nan Ling Village, Buji,
Rong Gang, Shenzhen, China.
This product complies with FDA radiation
performance standards, 21 CFR Subchapter J.

CHAPTER 1

GENERAL DESCRIPTION

CHAPTER 1 GENERAL DESCRIPTION

CONTENTS

1.1	EQUIPMENT OUTLINE	1-1
1.1.1	External Appearance and Weight	1-1
1.1.2	Components	1-1
1.2	SPECIFICATIONS.....	1-2

1.1 EQUIPMENT OUTLINE

1.1.1 External Appearance and Weight

The figure below shows the equipment appearance and approximate dimensions.

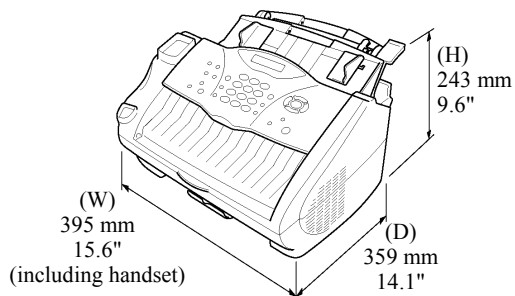

Weight:	Machine proper	Approx. 7.5 kg
	Machine (incl. drum unit & toner cartridge)	Approx. 8.7 kg
	In package	Approx. 11 kg

1.1.2 Components

The equipment consists of the following major components:

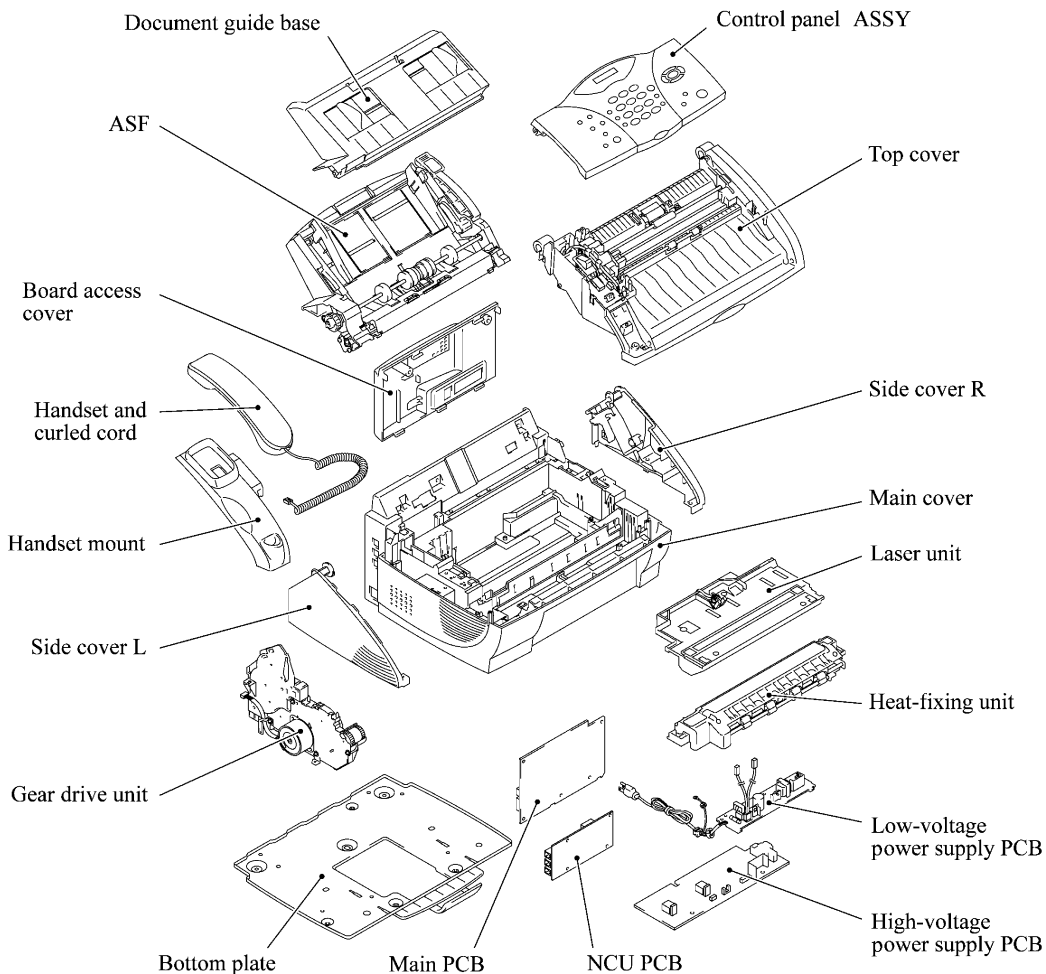

1.2 SPECIFICATIONS

FAX2800 (FAX2850)/FAX2900 (1/2)

Model Name	FAX2800 (FAX2850)	FAX2900
GENERAL		
Print Engine	Laser (YL4)	Laser (YL4)
Modem Speed(bps)	14,400(Fax)	14,400(Fax)
Transmission Speed(sec.)	6(Brother#1,MMR)	6(Brother#1,MMR)
ITU-T Group	G3	G3
Coding Method	MH/MR/MMR	MH/MR/MMR
Input/Output Width	5.8"-8.5"/3.5"-8.5"	5.8"-8.5"/3.5"-8.5"
Input/Output Length	5"-14"/5"-14"	5"-14"/5"-14"
ADF(pages)	up to 20	up to 30
LCD Size	16 Characters	16 Characters x 1 Line
LCD Backlight	No	No
Backup Clock	Yes (1 hour)	Yes (1 hour)
Memory Capacity (physical)	2MB (RAM)	4MB (RAM)
Optional Memory	N/A	N/A
Dimensions w/ Carton (WxDxH)	519mm x 454 mm x 375 mm	519mm x 454 mm x 375 mm
Dimensions w/o Carton (WxDxH)	395mm x 359mm x 243mm	395mm x 359mm x 243mm
Weight w/ Carton	11 Kg	11 Kg
Weight w/o Carton	7.5 Kg	7.5 Kg
Color	Gray 1495	Gray 1495
Operating Environment	Temperature 10 - 32.5 degrees Centigrade Humidity 20 - 80 %	10 - 32.5 degrees Centigrade 20 - 80 %
Power Source	120 VAC, 50/60Hz	120 VAC, 50/60Hz
Power Consumption (Sleep/Standby/Peak)	10W/ 70W/ 940W or less	10W/ 70W/ 940W or less
On/Off Switch	No	No
Starter Toner	Yes (1,000 pages)	Yes (1,000 pages)
Warm Up Time	Approx. 12 sec	Approx. 12 sec
TELEPHONE		
Handset	Yes	Yes
One-Touch Dial	8	8
Speed Dial	100	120
Speaker Phone	N/A	N/A
Chain Dialing	Yes	Yes
Caller ID	Yes	Yes
Call Waiting/Caller ID	Yes	Yes
Distinctive Ringing	Yes	Yes
Call Manage	Yes	Yes
Hold/Mute Key	Yes	Yes
Power Failure Dialing	N/A	N/A
Speaker Volume	Yes (3 steps + OFF)	Yes (3 steps + OFF)
Ring Volume	Yes (3 steps + OFF)	Yes (3 steps + OFF)
Handset Volume	Yes (2 steps + Amplify)	Yes (2 steps + Amplify)
PBX Feature	N/A	N/A
Transfer Method	No	No
FAX		
Internet FAX	N/A	N/A
Easy Receiver/Fax Detect	Yes	Yes
Fax/Tel Switch	Yes	Yes
Enhanced Remote Activate	Yes	Yes
Scan Speed (sec./page, A4:Standard)	Approx. 3.5	Approx. 3.5
Memory Transmission (Brother#1 Chart) (ITU-T Chart)	90 Pages(MMR/Standard Resolution) 80 Pages(MMR/Standard Resolution)	300 Pages(MMR/Standard Resolution) 250 Pages(MMR/Standard Resolution)
Broadcasting	Yes (158 locations)	Yes (178 locations)
Auto Reduction	Yes	Yes
Out-of-Paper Reception (Brother #1 Chart) (ITU-T Chart)	90 Pages(MMR/Standard Resolution) 80 Pages(MMR/Standard Resolution)	300 Pages(MMR/Standard Resolution) 250 Pages(MMR/Standard Resolution)
ECM(Error Correction Mode)	Yes	Yes
Group Dial	Yes (6)	Yes (6)
Color FAX (Document Send/Receive)	No / No	No / No
Color FAX (Memory Send/Receive)	No / No	No / No
Memory Backup	No	Yes
LIST/REPORT		
Activity Report/Journal Report	Yes (up to 200)	Yes (up to 200)
Transmission Verification Report	Yes	Yes
INTERFACE		
External TAD Interface	Yes	Yes
Host Interface (Serial)	No	No
Host Interface (IEEE1284)	No	Yes
Host Interface (USB)	No	Yes
LAN Interface	No	No
Acceptable Media Card Slot	N/A	N/A
Analog Video Port	N/A	N/A

FAX2800 (FAX2850)/FAX2900 (2/2)

Model Name	FAX2800 (FAX2850)	FAX2900
PRINTER		
Color/Mono	-	Mono
Engine Type	-	Laser (YL4)
Resolution(dpi)	-	600x600
Speed(ppm)	-	up to 10
Paper Capacity(sheets)	-	200
Output Paper Capacity(sheets)	-	50
Standard Print Language	-	Windows GDI
Emulation	-	No
Resident Fonts	-	No
Fonts Disk Based	-	No
Paper Handling Size	-	LTR, LGL, A4, B5, A5, EXE
Manual Feed Slot	-	N/A
Other Paper Type	-	OHP, Envelopes, Organizer
Sheet Weight (Paper Cassette)	-	64-158 g/m2 (16 - 42 lb)
(Manual Slot)	-	N/A
Printer Driver	-	Win95/98/98SE/Me/2000Professional/NT4.0WS
COPY		
Color/Mono	Mono	Mono
Speed(ppm)	up to 10	up to 10
Multi Copy(Stack)	Yes	Yes
Multi Copy(Sort)	No	No
Reduction/Enlargement(%)	50 to 200 in 1% increments	50 to 200 in 1% increments
Resolution(dpi)	200 x 300	200 x 300
First Copy Out Time (From Ready Mode)	Approx. 13 sec.	Approx. 13 sec.
SCANNER		
Color/Mono	No	No
Resolution(Optical : dpi)	-	-
Resolution(Int. : dpi)	-	-
Gray Scale	-	-
TWAIN Compliant & Operating System	-	-
PCI Scanner (Parallel/Serial)	-	-
BUNDLED SOFTWARE (For Windows)		
Printer Driver	No	Available download from Web
TWAIN	No	No
Viewer	No	No
Pop Up Menu	No	No
OCR	No	No
PC Fax	No	No
Remote Setup	No	No
PC Diagnostics	No	No
Others	-	-
BUNDLED SOFTWARE (For iMAC)		
Printer Driver	No	Available download from Web
TWAIN	No	No
Viewer	No	No
Pop Up Menu	No	No
OCR	No	No
PC Fax	No	No
Remote Setup	No	No
PC Diagnostics	No	No
Others	-	-
ACCESSORY		
Life / Yield		
Toner Starter (N/A)	1,000 pages	1,000 pages
Supply (TN-250)	2,200 pages	2,200 pages
Drum (DR-250)	20,000 pages: 20 pages/job 8,000 pages: 1 page/job	20,000 pages: 20 pages/job 8,000 pages: 1 page/job

Model Name	MFC4800	FAX3800
GENERAL		
Print Engine	Laser (YL4)	Laser (YL4)
Modem Speed(bps)	14,400(Fax)	33,600(Fax)
Transmission Speed(sec.)	6(Brother#1,MMR)	2(Brother#1,JBIG)
ITU-T Group	G3	Supper G3
Coding Method	MH/MR/MMR	MH/MR/MMR/JBIG
Input/Output Width	5.8"-8.5"/3.5"-8.5"	5.8"-8.5"/3.5"-8.5"
Input/Output Length	5"-14"/5"-14"	5"-14"/5"-14"
ADF(pages)	up to 20	up to 30
LCD Size	16 Characters x 1 Line	16 Characters x 1 Line
LCD Backlight	No	Yes
Backup Clock	Yes (1 hour)	Yes (1 hour)
Memory Capacity (physical)	2MB (RAM)	8MB (RAM)
Optional Memory	N/A	N/A
Dimensions w/ Carton (WxDxH)	519mm x 454 mm x 375 mm	519mm x 454 mm x 375 mm
Dimensions w/o Carton (WxDxH)	395mm x 359mm x 243mm	395mm x 359mm x 243mm
Weight w/ Carton	11 Kg	11 Kg
Weight w/o Carton	7.5 Kg	7.5 Kg
Color	Gray 1495	Gray 1495
Operating Environment	Temperature Humidity	Temperature Humidity
	10 - 32.5 degrees Centigrade 20 - 80 %	10 - 32.5 degrees Centigrade 20 - 80 %
Power Source	120 VAC, 50/60Hz	120 VAC, 50/60Hz
Power Consumption (Sleep/Standby/Peak)	10W/ 70W/ 940W or less	10W/ 70W/ 940W or less
On/Off Switch	No	No
Starter Toner	Yes (1,000 pages)	Yes (1,000 pages)
Warm Up Time	Approx. 12 sec	Approx. 12 sec
TELEPHONE		
Handset	Yes	Yes
One-Touch Dial	No	8
Speed Dial	100	120
Speaker Phone	N/A	N/A
Chain Dialing	Yes	Yes
Caller ID	Yes	Yes
Call Waiting Caller ID	Yes	N/A
Distinctive Ringing	Yes	Yes
Call Manage	Yes	Yes
Hold/Mute Key	Yes	Yes
Power Failure Dialing	N/A	N/A
Speaker Volume	Yes (3 steps + OFF)	Yes (3 steps + OFF)
Ring Volume	Yes (3 steps + OFF)	Yes (3 steps + OFF)
Handset Volume	Yes (2 steps + Amplify)	Yes (2 steps + Amplify)
PBX Feature	N/A	N/A
Transfer Method	No	No
FAX		
Internet FAX	N/A	N/A
Easy Receive/Fax Detect	Yes	Yes
Fax/Tel Switch	Yes	Yes
Enhanced Remote Activate	Yes	Yes
Scan Speed (sec./page, A4-Standard)	Approx. 3.5	Approx. 3.5
Memory Transmission (Brother#1 Chart)	90 Pages(MMR/Standard Resolution)	600 Pages(MMR/Standard Resolution)
(ITU-T Chart)	80 Pages(MMR/Standard Resolution)	500 Pages(MMR/Standard Resolution)
Broadcasting	Yes (150 locations)	Yes (178 locations)
Auto Reduction	Yes	Yes
Out-of-Paper Reception (Brother #1 Chart)	90 Pages(MMR/Standard Resolution)	600 Pages(MMR/Standard Resolution)
(ITU-T Chart)	80 Pages(MMR/Standard Resolution)	500 Pages(MMR/Standard Resolution)
ECM(Error Correction Mode)	Yes	Yes
Group Dial	Yes (6)	Yes (6)
Color FAX (Document Send/Receive)	No / No	No / No
Color FAX (Memory Send/Receive)	No / No	No / No
Memory Backup	No	Yes
LIST/REPORT		
Activity Report/Journal Report	Yes (up to 200)	Yes (up to 200)
Transmission Verification Report	Yes	Yes
INTERFACE		
External TAD Interface	Yes	Yes
Host Interface (Serial)	No	No
Host Interface (IEEE1284)	Yes	Yes
Host Interface (USB)	Yes	Yes
LAN Interface	No	No
Acceptable Media Card Slot	N/A	N/A
Analog Video Port	N/A	N/A

MFC4800/FAX3800 (2/2)

Model Name	MFC4800	FAX3800
PRINTER		
Color/Mono	Mono	Mono
Engine Type	Laser (YL4)	Laser (YL4)
Resolution(dpi)	600x600	600x600
Speed(ppm)	up to 10	up to 10
Paper Capacity(sheets)	200	200
Output Paper Capacity(sheets)	50	50
Standard Print Language	Windows GDI	Windows GDI
Emulation	No	No
Resident Fonts	No	No
Fonts Disk Based	Yes	No
Paper Handling Size	LTR, LGL, A4, B5, A5, EXE	LTR, LGL, A4, B5, A5, EXE
Manual Feed Slot	N/A	N/A
Other Paper Type	OHP, Envelopes, Organizer	OHP, Envelopes, Organizer
Sheet Weight (Paper Cassette)	64-158 g/m2 (16 - 42 lb)	64-158 g/m2 (16 - 42 lb)
(Manual Slot)	N/A	N/A
Printer Driver	Win95/98/98SE/Me/2000Professional/ NT4.0WS MacOS 8.5.1-9.1	Win95/98/98SE/Me/2000Professional/ NT4.0WS
COPY		
Color/Mono	Mono	Mono
Speed(ppm)	up to 10	up to 10
Multi Copy(Stack)	Yes	Yes
Multi Copy(Sort)	No	No
Reduction/Enlargement(%)	50 -- 200 in 1% increments	50 -- 200 in 1% increments
Resolution(dpi)	200 x 300	200 x 300
First Copy Out Time (From Ready Mode)	Approx. 13 sec.	Approx. 13 sec.
SCANNER		
Color/Mono	Mono	-
Resolution(Optical : dpi)	200x400	-
Resolution(Int. : dpi)	1,200x1,200	-
Gray Scale	256	-
TWAIN Compliant & Operating System	Win95/98/98SE/Me/NT4.0/2000Professional MacOS 8.6-9.1	-
PCI Scanner (Parallel/Serial)	Parallel/USB	-
BUNDLED SOFTWARE (For Windows)		
Printer Driver	Yes	Available download from Web
TWAIN	Yes	No
Viewer	Yes	No
Pop Up Menu	Yes	No
OCR	Yes	No
PC Fax	Yes (TX only)	No
Remote Setup	Yes	No
PC Diagnostics	No	No
Others	Auto E-mail Printing(Win 95/98/Me only)	-
BUNDLED SOFTWARE (For iMAC)		
Printer Driver	Yes	Available download from Web
TWAIN	Yes	No
Viewer	Yes	No
Pop Up Menu	No	No
OCR	Yes	No
PC Fax	Yes	No
Remote Setup	No	No
PC Diagnostics	No	No
Others	-	-
ACCESSORY		
Life / Yield		
Toner Starter (N/A)	1,000 pages	1,000 pages
Supply (TN-250)	2,200 pages	2,200 pages
Drum (DR-250)	20,000 pages: 20 pages/job 8,000 pages: 1 page/job	20,000 pages: 20 pages/job 8,000 pages: 1 page/job

Model Name	FAX-8070P	MFC-9070
GENERAL		
Print Engine	Laser (YL4)	Laser (YL4)
Modem Speed(bps)	14,400(Fax)	14,400(Fax)
Transmission Speed(sec.)	Approx.6 (Brother#1,MMR)	Approx.6(Brother#1,MMR)
ITU-T Group	G3	G3
Coding Method	MH/MR/MMR	MH/MR/MMR
Input/Output Width	5.8"-8.5"/3.5"-8.5"	5.8"-8.5"/3.5"-8.5"
Input/Output Length	5"-14"/5"-14"	5"-14"/5"-14"
ADF(pages)	up to 20 (75 g/m ²)	up to 20 (75 g/m ²)
LCD Size	16 Characters x 1 line	16 Characters x 1 line
LCD Backlight	Yes	Yes
On-Screen Programming	Yes	Yes
Backup Clock	Yes (9 hours)	Yes (9 hours)
Memory Capacity(physical)	2 MB(RAM)	8 MB(RAM)
Memory Backup	Yes (Max. 4 days)	Yes (Max. 4 days)
Optional Memory	N/A	N/A
Dimensions w/ Carton (WxDxH)	519mm x 454 mm x 375 mm	519mm x 454 mm x 375 mm
Dimensions w/o Carton (WxDxH)	395mm x 359mm x 243mm	395mm x 359mm x 243mm
Weight w/ Carton	11 Kg	11 Kg
Weight w/o Carton	7.5 Kg	7.5 Kg
Color	Gray 1495	Gray 1495
Operating Environment Temperature	10 - 32.5 degrees Centigrade	10 - 32.5 degrees Centigrade
Humidity	20 - 80 %	20 - 80 %
Power Source	220-240 VAC, 50/60Hz	220-240 VAC, 50/60Hz
Power Consumption (Sleep/Standby/Peak)	10W/70W/940W or less	10W/70W/940W or less
On/Off Switch	No	No
Starter Toner	No	No
TELEPHONE		
Handset	No	No
One-Touch Dial	8 locations	No
Speed Dial	100	100
Speaker Phone	N/A	N/A
Chain Dialing	Yes	Yes
Caller ID	N/A	N/A
Call Waiting Caller ID	N/A	N/A
Distinctive Ringing	Yes(UK, DEN only)	Yes(UK, DEN only)
Hold/Mute Key	N/A	N/A
Power Failure Dialing	N/A	N/A
Speaker Volume	Yes (3 steps + OFF)	Yes (3 steps + OFF)
Ring Volume	Yes (3 steps + OFF)	Yes (3 steps + OFF)
Handset Volume	N/A	N/A
PBX Feature	Yes	Yes
Transfer Method	Flash	Flash
FAX		
Internet FAX	N/A	N/A
Easy Receive/Fax Detect	Yes	Yes
Fax/Tel Switch	Yes	Yes
Enhanced Remote Activate	Yes	Yes
Quick-Scan(Memory transmission)	Yes as default, Approx.3.5 sec./page (A4 standard)	Yes as default, Approx.3.5 sec./page (A4 standard)
Memory Transmission (ITU-T Chart)	80 Pages(MMR/Standard Resolution)	400 Pages(MMR/Standard Resolution)
Broadcasting	Yes (158 locations)	Yes (150 locations)
Manual Broadcasting	Yes(50 locations)	Yes (50 locations)
Auto Reduction	Yes	Yes
Out-of-Paper Reception (ITU-T Chart)	80 Pages(MMR/Standard Resolution)	400 Pages(MMR/Standard Resolution)
ECM(Error Correction Mode)	Yes	Yes
Color FAX (Document Send/Receive)	No / No	No / No
Color FAX (Memory Send/Receive)	No / No	No / No
LIST/REPORT		
Activity Report/Journal Report	Yes (up to 200)	Yes (up to 200)
Transmission Verification Report	Yes	Yes
INTERFACE		
External TAD Interface	Yes	Yes
Host Interface (Serial)	No	No
Host Interface (IEEE1284)	No	Yes
Host Interface (USB)	No	Yes
LAN Interface	No	No
Acceptable Media Card Slot	N/A	N/A
Analog Video Port	N/A	N/A

Model Name	FAX-8070P	MFC-9070
PRINTER		
Color/Mono	-	Mono
Engine Type	-	Laser (YL4)
Resolution(dpi)	-	600x600
Speed(ppm)	-	up to 10
Paper Capacity(sheets)	-	200 (75 g/m ²)
Additional Paper Capacity(sheets)	-	No
Output Paper Capacity(sheets)	-	50
Standard Print Language	-	Windows GDI
Emulation	-	Yes(PCL5e)
Resident Fonts	-	Yes(Bitmap font: LetterGothic16.66, OCR-A, OCR-B, Scaleable font; 49 fonts)
Fonts Disk Based	-	Yes
Paper Handling Size	-	LTR, LGL, A4, B5, A5, EXE, A6, B6
Manual Feed Slot	-	N/A
Other Paper Type	-	OHP, Envelopes, Organizer
Sheet Weight (Paper Cassette)	-	64-158 g/m ² (16 - 42 lb)
(Manual Slot)	-	N/A
Printer Driver	-	Win95/98/98SE/Me, WinNT4.0WS/2000Professional
COPY		
Color/Mono	Mono	Mono
Speed(ppm)	up to 10	up to 10
Multi Copy(Stack)	Yes	Yes
Multi Copy(Sort)	No	Yes
Reduction/Enlargement(%)	50 to 200 in 1% increments	50 to 200 in 1% increments
Resolution(dpi)	200 x 300	200 x 300
SCANNER		
Color/Mono	-	Mono
Resolution(Optical : dpi)	-	200x400
Resolution(Int. : dpi)	-	1,200x1,200
Gray Scale	-	256
TWAIN Compliant & Operating System	-	Win95/98/98SE/Me, WinNT4.0WS/2000Professional
PCI Scanner (Parallel/Serial)	-	Parallel/USB
BUNDLED SOFTWARE (For Windows)		
Printer Driver	No	Yes
TWAIN	No	Yes
Viewer	No	Yes
Pop Up Menu	No	Yes
OCR	No	Yes
PC Fax	No	Yes
Remote Setup	No	Yes
PC Diagnostics	Yes	Yes
Others	-	Auto E-mail Printing(Win 95/98/Me only)
BUNDLED SOFTWARE (For iMAC)		
Printer Driver	No	Yes
TWAIN	No	Yes
Viewer	No	Yes
Pop Up Menu	No	No
OCR	No	Yes
PC Fax	No	No
Remote Setup	No	No
PC Diagnostics	Yes	No
Others	-	No
ACCESSORY		
Life / Yield	TN-8000(Toner) (2,200 pages w/5% coverage) DR-8000 (Drum) (20,000 pages: Continuous Printing) DR-8000(Drum) (8,000 pages:1 page/job)	TN-8000(Toner) (2,200 pages w/5% coverage) DR-8000 (Drum) (20,000 pages: Continuous Printing) DR-8000(Drum) (8,000 pages:1 page/job)

MFC-9030 (1/2)

Model Name	MFC-9030
GENERAL	
Print Engine	Laser (YL4)
Modem Speed(bps)	14,400(Fax)
Transmission Speed(sec.)	Approx.6(Brother#1,MMR)
ITU-T Group	G3
Coding Method	MH/MR/MMR
Input/Output Width	5.8"-8.5"/3.5"-8.5"
Input/Output Length	5"-14"/5"-14"
ADF(pages)	up to 20 (75 g/m ²)
LCD Size	16 Characters x 1 line
LCD Backlight	No
On-Screen Programming	Yes
Backup Clock	Yes (9 hours)
Memory Capacity(physical)	2 MB(RAM)
Memory Backup	Yes (Max. 4 days)
Optional Memory	N/A
Dimensions w/ Carton (WxDxH)	519mm x 454 mm x 375 mm
Dimensions w/o Carton (WxDxH)	395mm x 359mm x 243mm
Weight w/ Carton	11 Kg
Weight w/o Carton	7.5 Kg
Color	Gray 1495
Operating Environment	Temperature Humidity
	10 - 32.5 degrees Centigrade 20 - 80 %
Power Source	220-240 VAC, 50/60Hz
Power Consumption (Sleep/Standby/Peak)	10W/70W/940W or less
On/Off Switch	No
Starter Toner	No
TELEPHONE	
Handset	No
One-Touch Dial	No
Speed Dial	100
Speaker Phone	N/A
Chain Dialing	Yes
Caller ID	N/A
Call Waiting Caller ID	N/A
Distinctive Ringing	Yes(UK, DEN only)
Hold/Mute Key	N/A
Power Failure Dialing	N/A
Speaker Volume	Yes (3 steps + OFF)
Ring Volume	Yes (3 steps + OFF)
Handset Volume	N/A
PBX Feature	Yes
Transfer Method	Flash
FAX	
Internet FAX	N/A
Easy Receive/Fax Detect	Yes
Fax/Tel Switch	Yes
Enhanced Remote Activate	Yes
Quick-Scan(Memory transmission)	Yes as default, Approx.3.5 sec./page (A4 standard)
Memory Transmission (ITU-T Chart)	80 Pages(MMR/Standard Resolution)
Broadcasting	Yes (150 locations)
Manual Broadcasting	Yes (50 locations)
Auto Reduction	Yes
Out-of-Paper Reception (ITU-T Chart)	80 Pages(MMR/Standard Resolution)
ECM(Error Correction Mode)	Yes
Color FAX (Document Send/Receive)	No / No
Color FAX (Memory Send/Receive)	No / No
LIST/REPORT	
Activity Report/Journal Report	Yes (up to 200)
Transmission Verification Report	Yes
INTERFACE	
External TAD Interface	Yes
Host Interface (Serial)	No
Host Interface (IEEE1284)	Yes
Host Interface (USB)	Yes
LAN Interface	No
Acceptable Media Card Slot	N/A
Analog Video Port	N/A

MFC-9030 (2/2)

Model Name	MFC-9030
PRINTER	
Color/Mono	Mono
Engine Type	Laser (YL4)
Resolution(dpi)	600x600
Speed(ppm)	up to 8
Paper Capacity(sheets)	200 (75 g/m ²)
Additional Paper Capacity(sheets)	No
Output Paper Capacity(sheets)	50
Standard Print Language	Windows GDI
Emulation	No
Resident Fonts	No
Fonts Disk Based	Yes
Paper Handling Size	LTR, LGL, A4, B5, A5, EXE, A6, B6
Manual Feed Slot	N/A
Other Paper Type	OHP, Envelopes, Organizer
Sheet Weight (Paper Cassette)	64-158 g/m ² (16 - 42 lb)
(Manual Slot)	N/A
Printer Driver	Win95/98/98SE/Me, WinNT4.0WS/2000Professional
COPY	
Color/Mono	Mono
Speed(ppm)	up to 10
Multi Copy(Stack)	Yes
Multi Copy(Sort)	No
Reduction/Enlargement(%)	50 to 200 in 1% increments
Resolution(dpi)	200 x 300
SCANNER	
Color/Mono	Mono
Resolution(Optical : dpi)	200x400
Resolution(Int. : dpi)	1,200x1,200
Gray Scale	256
TWAIN Compliant & Operating System	Win95/98/98SE/Me, WinNT4.0WS/2000Professional
PCI Scanner (Parallel/Serial)	Parallel/USB
BUNDLED SOFTWARE (For Windows)	
Printer Driver	Yes
TWAIN	Yes
Viewer	Yes
Pop Up Menu	Yes
OCR	Yes
PC Fax	Yes
Remote Setup	Yes
PC Diagnostics	Yes
Others	Auto E-mail Printing(Win 95/98/Me only)
BUNDLED SOFTWARE (For iMAC)	
Printer Driver	Yes
TWAIN	Yes
Viewer	Yes
Pop Up Menu	No
OCR	Yes
PC Fax	No
Remote Setup	No
PC Diagnostics	No
Others	No
ACCESSORY	
Life / Yield	TN-8000(Toner) (2,200 pages w/5% coverage) DR-8000 (Drum) (20,000 pages: Continuous Printing) DR-8000(Drum) (8,000 pages:1 page/job)

CHAPTER 2

INSTALLATION

CHAPTER 2 INSTALLATION

CONTENTS

2.1	INSTALLING THE UPDATE DATA TO THE FACSIMILE MACHINE.....	2-1
2.2	SETTING ID CODES TO FACSIMILE MACHINES	2-3

2.1 INSTALLING THE UPDATE DATA TO THE FACSIMILE MACHINE

If the program version is updated or the main PCB is replaced, then install the update program onto the flash ROM of the main PCB.

The program installation requires a PC/AT-compatible computer (which is capable of running MS-DOS or its compatible OS).

Connecting the facsimile machine to your computer

- (1) Make sure that your computer is turned off.
- (2) Make sure that the machine's power cord is unplugged from a wall socket. (If the machine has a power ON/OFF switch, make sure that the switch is turned off.)
- (3) Connect the parallel interface cable to the parallel port on the back of the machine and secure it with the lock wires.
- (4) Connect the other end of the interface cable to the printer port of your computer and secure it with the two screws.
- (5) While pressing the **5** key on the machine's control panel, plug the machine's power cord into a wall socket (or turn on the power ON/OFF switch if the machine has the switch).
- (6) Check to see that the following pattern displays on the LCD. If it does not display, go back to step (2) above.

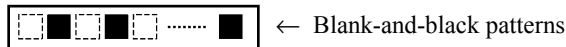

- (7) Turn on your computer.

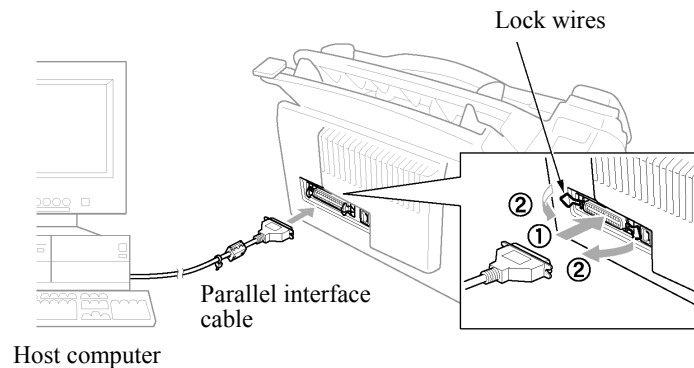

Installing the update data onto the flash ROM of the facsimile machine

NOTE: The following is an installation procedure example on a PC that is running Windows 95/98.

- (1) Copy the update data and transfer utility onto the desired directory of the hard disk.
e.g., C:\UPDATE
- (2) Click the Start button, point to Programs, and then click MS-DOS Prompt to open an MS-DOS window.
- (3) Type the drive letter where the update data and transfer utility are located. In the above example, type C:\ from the command line and press the **ENTER** key.

Then type CD UPDATE and press the **ENTER** key.

- (4) Check that your computer is connected with the facsimile machine correctly.
- (5) To start the transfer utility transmitting the update data to the flash ROM of the facsimile machine, type the following:

```
ICEN filename /b
```

Then press the **ENTER** key.

During downloading, the machine beeps *intermittently*.

Upon completion of the downloading, the machine beeps *continuously*.

NOTE: If the facsimile machine cannot return to the standby state after completion of downloading, turn the power off and on.

2.2 SETTING ID CODES TO FACSIMILE MACHINES

■ Function

Brother facsimile machines are assigned unique ID codes (character strings) at the factory. If you replace the main PCB of the machine, the machine will lose its assigned ID code so that it will not be identified by the connected PC*.

You need to assign a unique ID code (character string) to the machine according to the procedure given here. For models covered by this manual, set serial numbers given to individual machines as ID codes.

(*ID codes are essential when more than one machine is connected to a single PC via USB.)

■ Connecting each of facsimile machines to your PC

- (1) Make sure that your PC is turned off.
- (2) Make sure that the machine's power cord is unplugged from a wall socket.
- (3) Connect the interface cable to the parallel interface port on the back of the facsimile machine and secure it with the lock wires.
- (4) Connect the other end of the interface cable to the printer port of your PC and secure it with the two screws.
- (5) Plug the machine's power cord into a wall socket.
- (6) Turn on your PC.

■ Operating Procedure

- (1) On your PC, run the ID setting utility. Follow the instructions shown on the PC's screen and enter the 9-digit serial number (e.g., G01012345) printed on the nameplate labeled to the back of the facsimile machine as an ID code. Then press the Enter key.

The ID setting utility will transmit the ID code data from your PC to the facsimile machine and then it will terminate.

The facsimile machine will automatically return to the standby mode.

- (2) To check whether the entered character string (ID code) is correct, make the machine enter the maintenance mode (refer to CHAPTER 5, Section 5.1) and then press the **1** key twice (Subsection 5.3.5).

The facsimile machine will print out a Configuration List. At the right top of the list, "SER.#: BROXXXXXXXX" is printed.

- (3) Check that the character string entered in step (2) is printed in "XXXXXXXXXX."

If it is OK, press the **9** key twice to exit from the maintenance mode.

If something other than that is printed in XXXXXXXXXXX, check the connection between the PC and facsimile machine and go back to step (1).

CHAPTER 3

THEORY OF OPERATION

CHAPTER 3 THEORY OF OPERATION

CONTENTS

3.1	OVERVIEW	3-1
3.2	MECHANISMS	3-2
3.2.1	Scanner Mechanism	3-3
3.2.1.1	Document feeding and ejecting mechanism	3-3
3.2.1.2	Scanner	3-3
3.2.2	Laser Printing Mechanism	3-4
3.2.2.1	Paper pulling-in, registration, feeding, and ejecting mechanism	3-4
3.2.2.2	Print process mechanism	3-6
3.2.2.3	Heat-fixing mechanism	3-7
3.2.3	Sensors and Actuators	3-8
3.3	CONTROL ELECTRONICS	3-10
3.3.1	Configuration	3-10

3.1 OVERVIEW

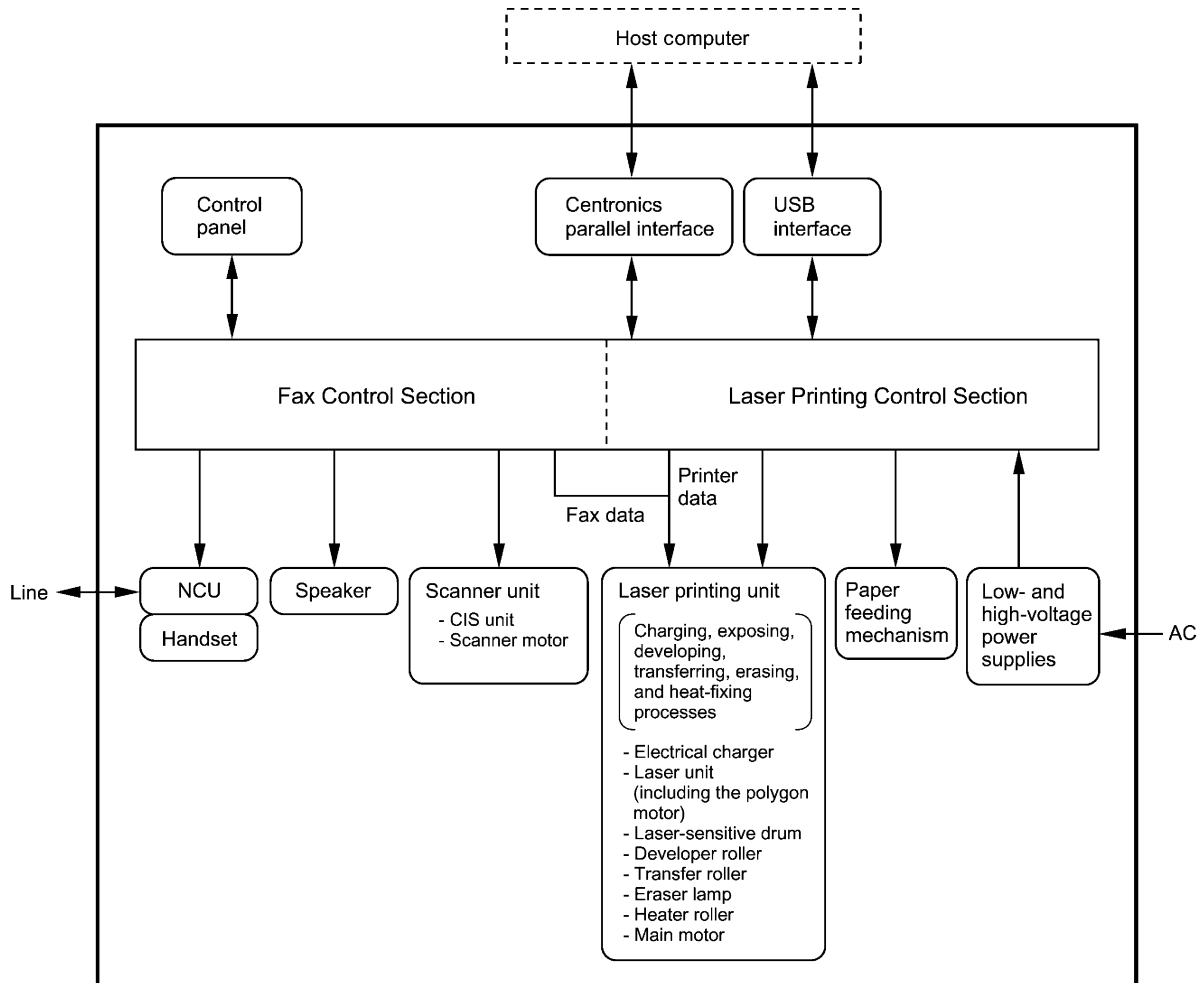

3.2 MECHANISMS

The facsimile machine is classified into the following mechanisms:

- SCANNER MECHANISM
 - Document feeding and ejecting mechanism
 - Document scanning mechanism
- LASER PRINTING MECHANISM
 - Paper pulling-in, registration, feeding, and ejecting mechanisms
 - Print process mechanism (consisting of charging, exposing, developing, transferring, and erasing processes)
 - Heat-fixing mechanism
- SENSORS AND ACTUATORS

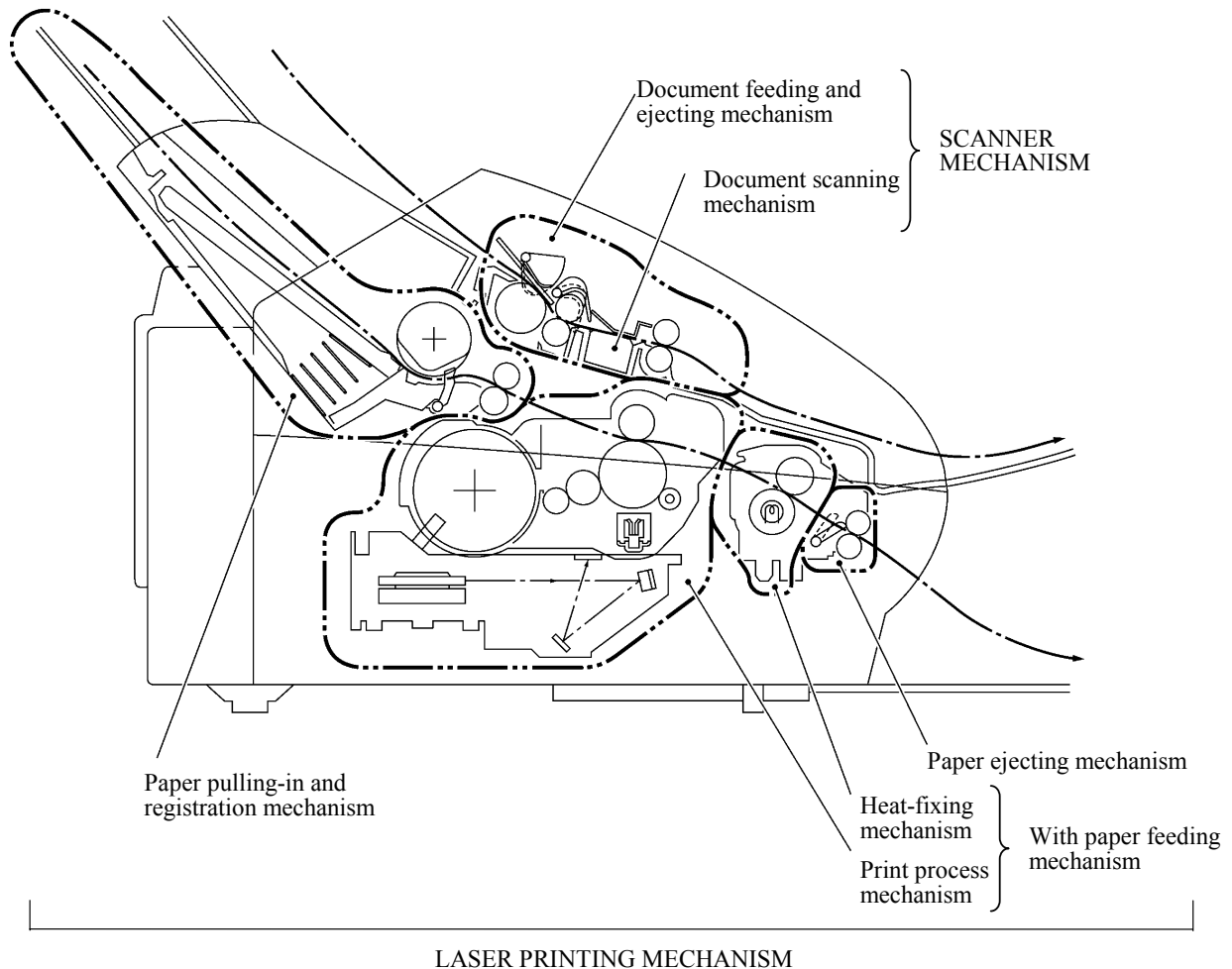

3.2.1 Scanner Mechanism

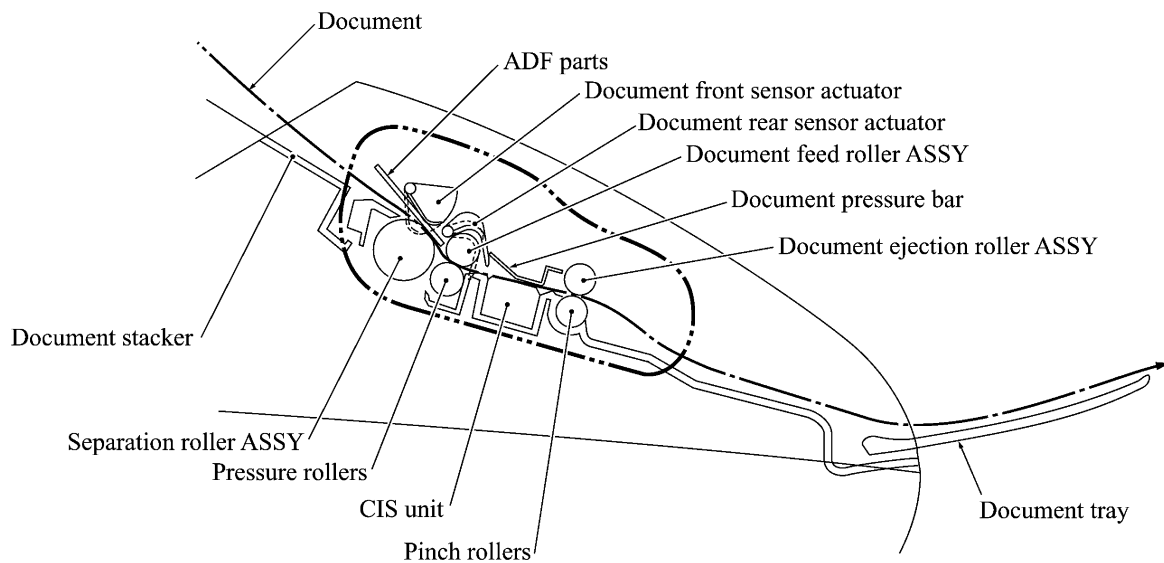

3.2.1.1 Document feeding and ejecting mechanism

This mechanism consists of the document stacker, automatic document feeder (ADF), document ejection roller ASSY, and document sensors. (For details about the sensors, refer to Subsection 3.2.3.)

If you set documents on the document stacker with their faces down and start the scanning operation, then the scanner motor rotates so that the ADF (which consists of the separation roller and ADF parts) feeds those documents into the machine, starting from the bottom sheet (first page) to the top (last page), page by page. Each document advances with the document feed roller ASSY to the scanner, and then it is fed out of the machine with the document ejection roller ASSY.

3.2.1.2 Scanner

The scanner uses a contact image sensor (CIS) unit which consists of an LED array illuminating documents, a self-focus lens array collecting the reflected light, a CIS PCB carrying out photoelectric conversion to output picture element data, and a cover glass on which a document advances. When the document passes between the document pressure bar and the cover glass, it is scanned.

3.2.2 Laser Printing Mechanism

3.2.2.1 Paper pulling-in, registration, feeding, and ejecting mechanism

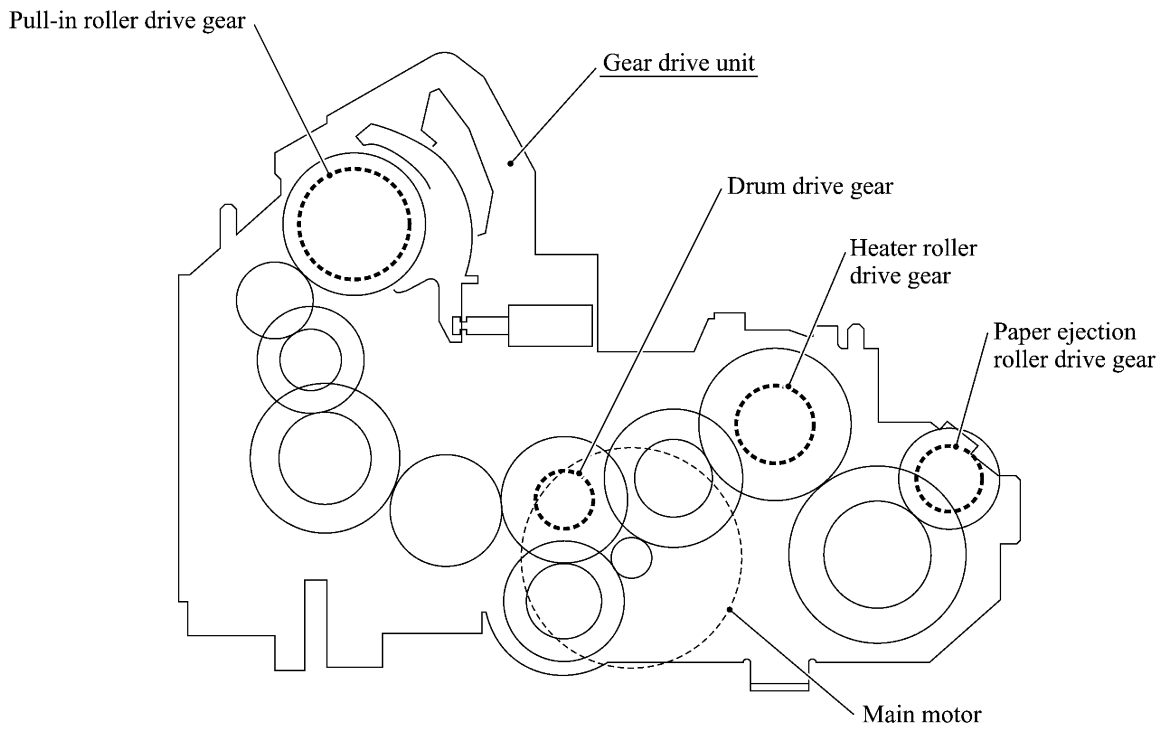
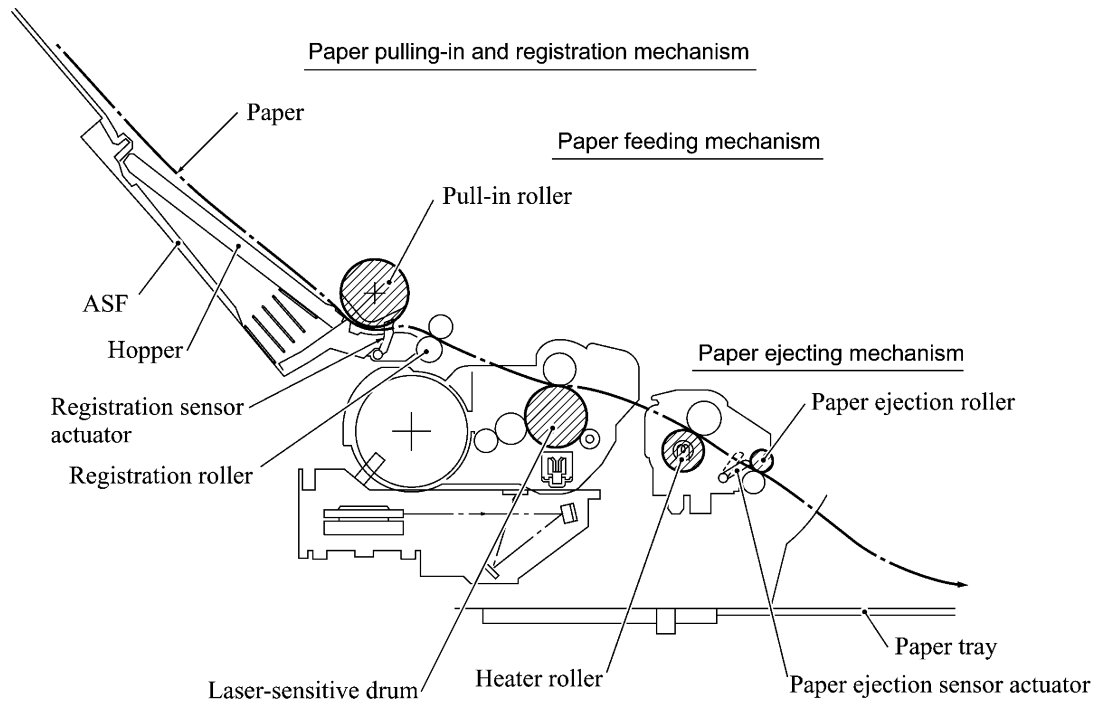

Paper pulling-in and registration mechanism

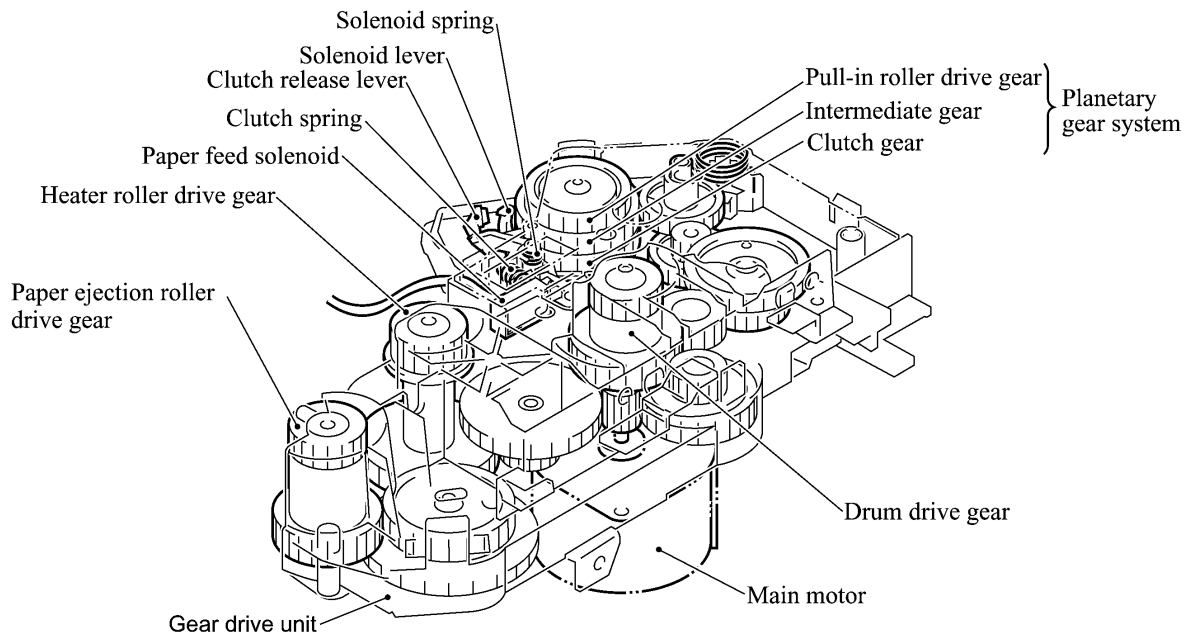

The paper pulling-in and registration mechanism consists of the pull-in roller gear (incorporated in the auto sheet feeder ASF), planetary gear system, paper feed solenoid, solenoid lever, clutch release lever, and registration sensor. (For the details about the sensor, refer to Subsection 3.2.3.)

If the main motor rotates clockwise, the rotation is transmitted to the intermediate gear of the planetary gear system. As the intermediate gear rotates, the pull-in roller drive gear also rotates since the clutch gear is locked by the solenoid lever and the clutch release lever. Accordingly, the pull-in roller in the ASF rotates to pull in paper into the machine, a sheet at a time.

If the paper feed solenoid is retracted and the clutch release lever is operated according to the cam profile of the pull-in roller drive gear so as to release the clutch gear, the clutch gear rotates and the pull-in roller drive gear does not rotate. This way, the clutch gear switches the transmission of the motor rotation to the pull-in roller drive gear on and off.

The solenoid on/off timing and the clutch release lever timing allow this mechanism to pull in a sheet and register it against the registration roller.

Paper feeding and ejecting mechanism

If the main motor rotates clockwise, the rotation is transmitted via the gear train to the drum drive gear, heater roller drive gear, and paper ejection roller drive gear.

After the paper passes through the heat-fixing process, it will be ejected onto the paper tray.

If the leading edge of the paper pushes up the actuator of the paper ejection sensor, the photosensor becomes opened, signaling the start of paper ejection. If the trailing edge has passed through the sensor actuator, the sensor becomes closed, signaling the completion of paper ejection. Then, the main motor stops rotation.

3.2.2.2 Print process mechanism

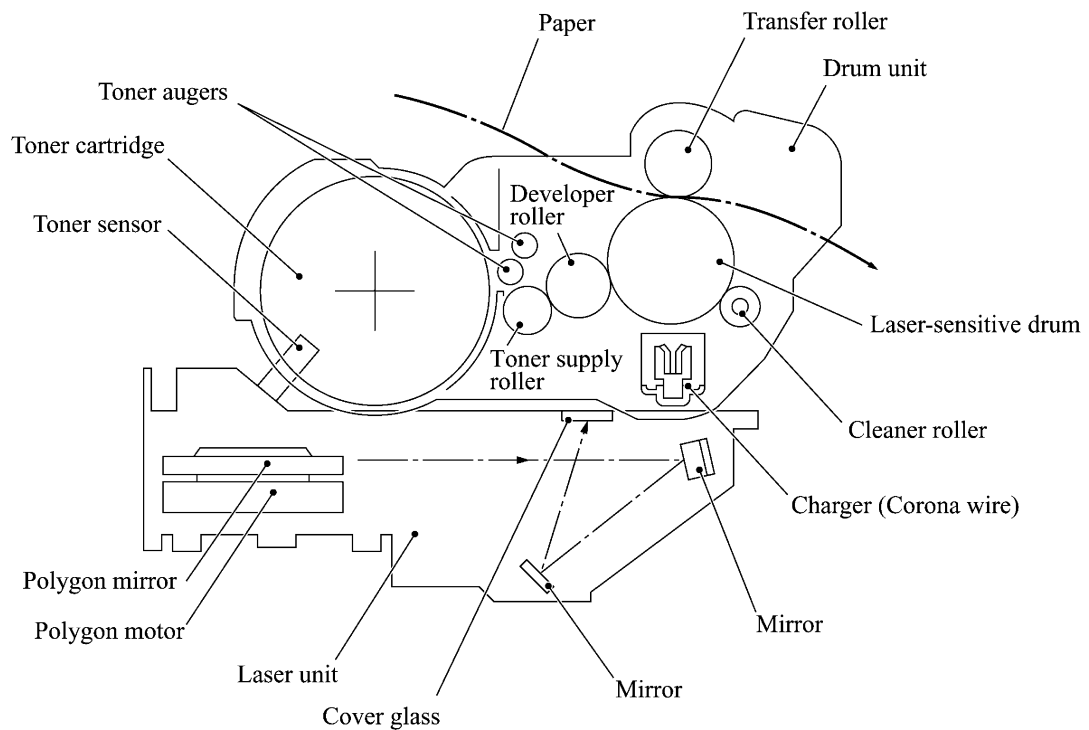

The print process unit works with laser beam, electrical charges, and toner. The graph below shows the transition of electrical charge on the surface of the laser-sensitive drum through the five processes: charging, exposing, developing, transferring, and erasing processes.

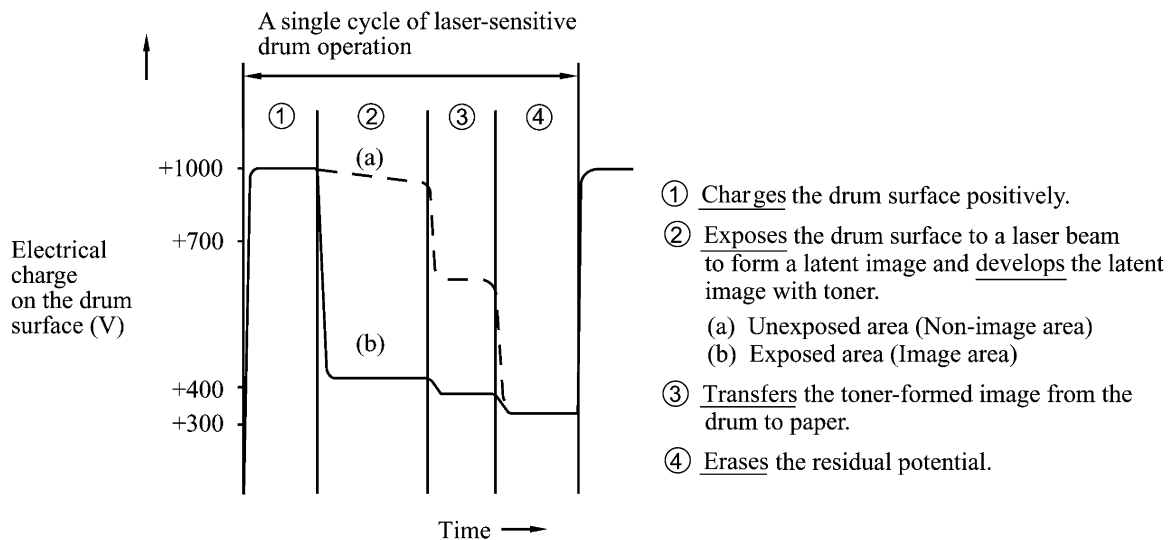

3.2.2.3 Heat-fixing mechanism

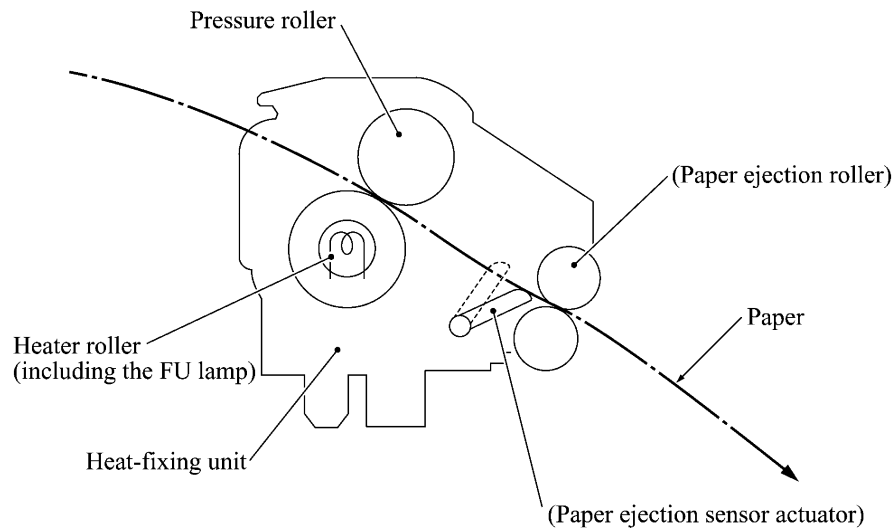

As the paper passes between the heater roller and the pressure roller in the heat-fixing unit, the heater roller fuses the toner on the paper.

3.2.3 Sensors and Actuators

This machine has nine sensors: six photosensors, two thermistors and, a mechanical switch as described below.

Sensor name	Type	Located on
Document front sensor	Photosensor	Control panel PCB
Document rear sensor	Photosensor	
Cover sensor	Photosensor	Cover/registration sensor PCB
Registration sensor	Photosensor	
Paper ejection sensor	Photosensor	High-voltage power supply PCB
Toner sensor	Photosensor	Toner sensor PCB
Toner thermistor	Thermistor	Toner sensor PCB
Heater thermistor	Thermistor	Heat-fixing unit
Hook switch	Mechanical switch	Hook switch PCB

- Document front sensor which detects the presence of documents.
- Document rear sensor which detects the leading and trailing edges of pages to tell the control circuitry when the leading edge of a new page has reached the starting position and when the scan for that page is over.
- Cover sensor which detects whether the top cover is closed.
- Registration sensor which detects the leading and trailing edges of paper, which allows the controller to determine the registration timing and check paper jam.
- Paper ejection sensor which detects whether the recording paper goes out of the machine.
- Toner sensor which detects whether there is toner or a toner cartridge is loaded.
- Toner thermistor which allows the controller to monitor the ambient temperature of the toner cartridge.
- Heater thermistor which allows the controller to monitor the temperature of the heater roller of the fixing unit.
- Hook switch which detects whether the handset is placed on the handset mount.

These photosensors are a photointerrupter consisting of a light-emitting diode and a light-sensitive transistor. Each of them has an actuator separately arranged as shown on the next page.

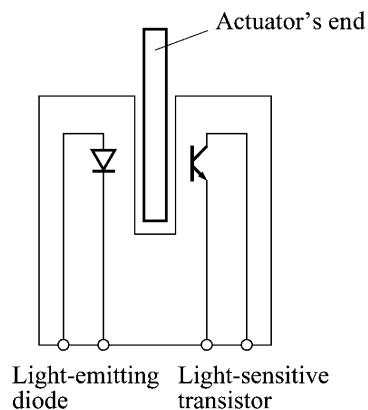

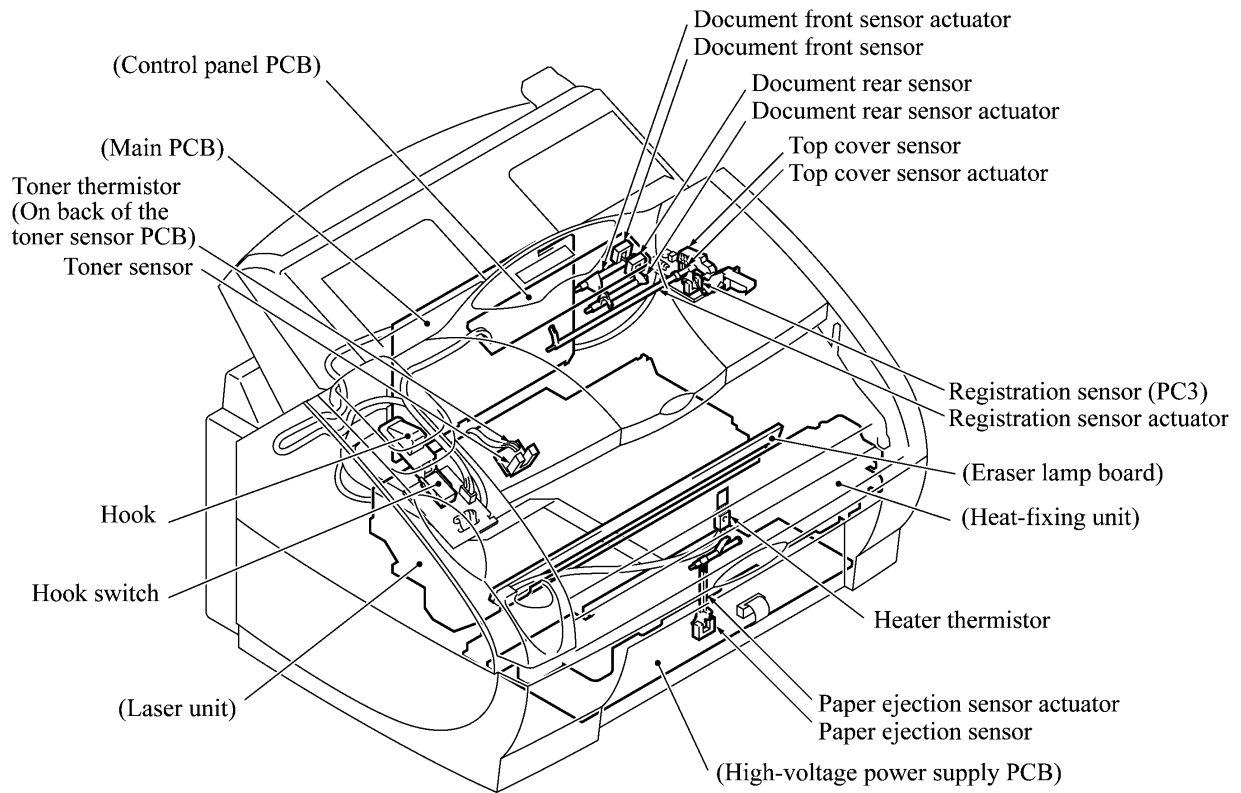

Location of Sensors and Actuators

3.3 CONTROL ELECTRONICS

3.3.1 Configuration

The hardware configuration of the facsimile machine is shown below.

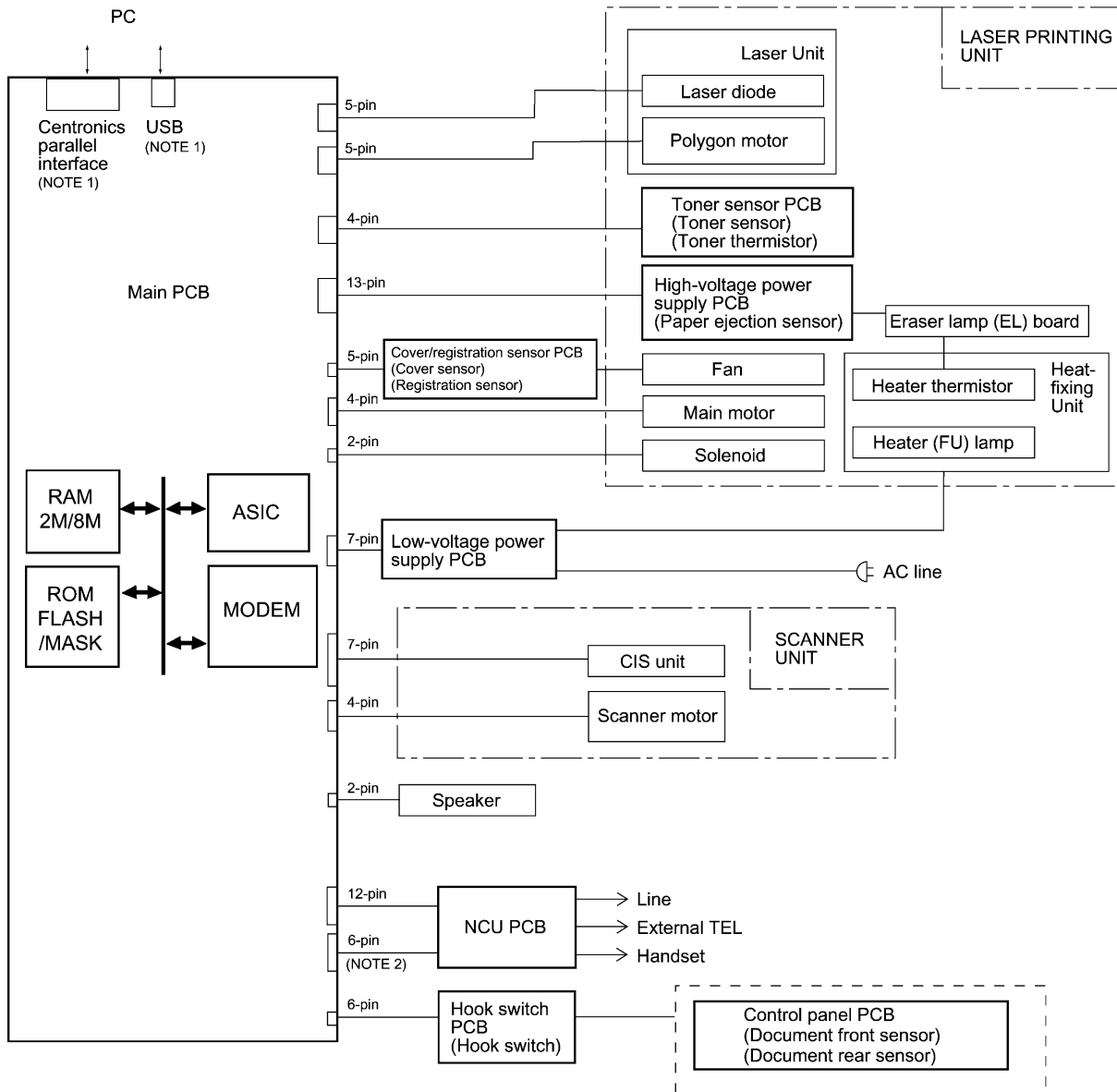

Configuration of Facsimile Machine

(NOTE 1) Not provided on some models.

(NOTE 2) Provided on the European, Pacific, and Asian versions.

CHAPTER 4

DISASSEMBLY/REASSEMBLY AND LUBRICATION

CHAPTER 4 DISASSEMBLY/REASSEMBLY AND LUBRICATION

CONTENTS

4.1 DISASSEMBLY/REASSEMBLY	4-1
■ Safety Precautions	4-1
Tightening Torque List	4-2
■ Preparation	4-3
■ How to Access the Object Component	4-3
■ Disassembly Order Flow	4-4
4.1.1 Document Guide Base	4-5
4.1.2 Board Access Cover	4-5
4.1.3 Auto Sheet Feeder (ASF)	4-6
4.1.4 Handset Mount and Control Panel ASSY	4-12
4.1.5 Panel Rear Cover and Control Panel	4-14
4.1.6 Top Cover	4-17
4.1.7 CIS Unit	4-19
4.1.8 Hook Switch PCB	4-20
4.1.9 Document Feed Roller ASSY, Scanner Drive Unit, and Document Ejection Roller ASSY	4-21
4.1.10 Separation Roller and its Gear	4-23
4.1.11 Heat-fixing Unit, FU Lamp, and Paper Ejection Sensor Actuator	4-25
4.1.12 Laser Unit and Toner Sensor PCB	4-27
4.1.13 Main PCB	4-28
4.1.14 Bottom Plate	4-30
4.1.15 Low-voltage Power Supply PCB	4-31
4.1.16 High-voltage Power Supply PCB	4-32
4.1.17 Cover/Registration Sensor PCB, Duct, and Fan	4-33
4.1.18 Top Cover Sensor Actuator	4-34
4.1.19 Power Supply Shield	4-34
4.1.20 Speaker	4-35
4.1.21 Gear Drive Unit	4-36

4.1.22 PCB Support and NCU PCB	4-38
4.1.23 Side Covers R and L	4-39
4.1.24 Scanner Grounding Plate	4-40
4.1.25 EL (Eraser Lamp) Board	4-41
4.1.26 Harness Routing.....	4-42
4.1.27 Cleaning of High-voltage Contacts and Grounding Contacts.....	4-46
4.2 LUBRICATION	4-47

4.1 DISASSEMBLY/REASSEMBLY

■ Safety Precautions

To prevent the creation of secondary problems by mishandling, observe the following precautions during maintenance work.

- (1) Unplug the power cord from the power outlet before replacing parts or units. When having access to the power supply, be sure to unplug the power cord from the power outlet.
- (2) When servicing the optical system of the laser printing unit, be careful not to place screwdrivers or other reflective objects in the path of the laser beam. Be sure to take off any personal accessories such as wrist watches and rings before working on the printer. A reflected beam, though invisible, can permanently damage your eyes.
- (3) If the machine has been printing, allow the heat-fixing unit sufficient time to cool down before starting maintenance jobs. It is HOT!
- (4) Be careful not to lose screws, washers, or other parts removed for parts replacement.
- (5) Do not remove gears from the document feed roller ASSY or ejection roller ASSY if at all possible. Once removed, they will become unusable and new gears will have to be put back in.
- (6) When using soldering irons and other heat-generating tools, take care not to damage the resin parts such as wires, PCBs, and covers.
- (7) Before handling the PCBs, touch a metal portion of the machine to discharge static electricity; otherwise, the electronic parts may be damaged due to the electricity charged in your body.
- (8) When transporting PCBs, be sure to wrap them in conductive sheets such as aluminum foil.
- (9) Be sure to reinsert self-tapping screws correctly, if removed.
- (10) Tighten screws to the torque values listed on the next page.
- (11) When connecting or disconnecting cable connectors, hold the connector bodies not the cables. If the connector has a lock, always slide the connector lock to unlock it.
- (12) Before reassembly, apply the specified lubricant to the specified points. (Refer to Subsection 4.2 in this chapter.)
- (13) After repairs, check not only the repaired portion but also that the connectors and other related portions function properly before operation checks.

Tightening Torque List

Location	Screw type	Q'ty	Tightening torque N•m (kgf•cm)	
Board access cover	Taptite, bind B M4x12	2	0.78 ±0.10	(8 ±1)
Release lever	Taptite, bind B M4x10	1	0.98 ±0.20	(10 ±2)
Grounding leaf spring R	Taptite, bind B M2.6x8	1	0.39 ±0.10	(4 ±1)
Grounding leaf spring L	Taptite, bind B M2.6x8	2	0.39 ±0.10	(4 ±1)
ADF parts	Taptite, pan B M3x6	1	0.49 ±0.20	(5 ±2)
Panel rear cover	Taptite, cup B M3x8	2	0.49 ±0.20	(5 ±2)
Link stoppers	Taptite, pan B M4x6D 10	2	0.49 ±0.20	(5 ±2)
FG wire & main PCB	Taptite, cup S M3x6	1	0.69 ±0.20	(7 ±2)
CIS shield plate	Taptite, cup B M3x6	3	0.49 ±0.20	(5 ±2)
Scanner drive unit	Taptite, cup B M3x8	2	0.49 ±0.20	(5 ±2)
Scanner motor	Screw, pan (washer) M3x6DA	1	0.69 ±0.20	(7 ±2)
Heat-fixing unit	Taptite, cup B M4x16	2	0.98 ±0.20	(10 ±2)
Fixing unit upper cover	Taptite, bind B M3x12	2	0.69 ±0.20	(7 ±2)
Lock plate	Taptite, pan B M3x10	1	0.69 ±0.20	(7 ±2)
Fuse plate R	Screw, pan (washer) M2.6x6DA	1	0.39 ±0.10	(4 ±1)
Laser unit	Taptite, bind B M4x12	3	0.98 ±0.20	(10 ±2)
Main shield	Taptite, cup S M3x6	2	0.69 ±0.20	(7 ±2)
Parallel interface connector	Taptite, pan S M3x12	2	0.69 ±0.20	(7 ±2)
Main PCB	Taptite, cup S M3x6	1	0.69 ±0.20	(7 ±2)
Bottom plate	Taptite, bind B M4x12	5	0.98 ±0.20	(10 ±2)
	Taptite, cup S M3x6	4	0.69 ±0.20	(7 ±2)
Low-voltage power supply PCB (Low-voltage insulator sheet)	Taptite, cup S M3x6	2	0.69 ±0.20	(7 ±2)
Grounding wire	Screw, pan (washer) M4x8DB	1	0.39 ±0.20	(4 ±2)
Power inlet support	Taptite, cup S M3x6	1	0.69 ±0.20	(7 ±2)
High-voltage power supply PCB	Taptite, bind B M4x12	1	0.98 ±0.20	(10 ±2)
Duct	Taptite, bind B M4x12	2	0.98 ±0.20	(10 ±2)
Fan support	Taptite, cup B M3x8	1	0.49 ±0.20	(5 ±2)
Power supply shield	Taptite, cup S M3x6	2	0.69 ±0.20	(7 ±2)
Gear drive unit	Taptite, bind B M4x14	4	0.98 ±0.20	(10 ±2)
Main motor	Taptite, cup S M3x6	2	0.69 ±0.20	(7 ±2)
Motor support plate	Taptite, cup S M3x16	2	0.69 ±0.20	(7 ±2)
PCB support	Taptite, bind B M4x12	2	0.98 ±0.20	(10 ±2)
NCU shield	Taptite, cup S M3x6	2	0.69 ±0.20	(7 ±2)
NCU PCB	Taptite, cup S M3x6	1	0.69 ±0.20	(7 ±2)
Scanner grounding plate	Taptite, cup B M3x8	1	0.49 ±0.20	(5 ±2)
Side covers R and L	Taptite, bind B M4x12	4	0.98 ±0.20	(10 ±2)

■ Preparation

Prior to proceeding to the disassembly procedure,

(1) Unplug

- the modular jack of the telephone line,
- the modular jack of the curled cord (and remove the handset),
- the PC interface cable (parallel cable or USB cable) if connected (Not shown below), and
- the modular jack of an external telephone set if connected (Not shown below).

(2) Remove

- the paper support,
- the document support,
- the document tray,
- the paper tray, and
- the drum unit (with the toner cartridge loaded)

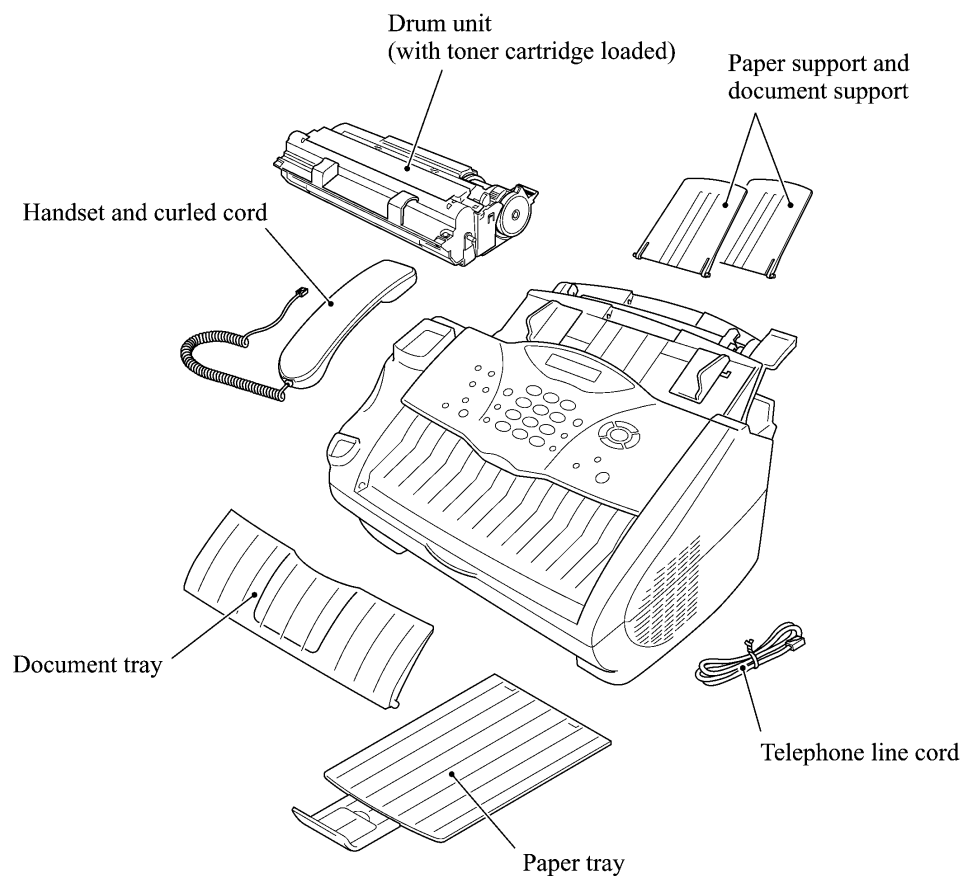

■ How to Access the Object Component

- On the next page is a disassembly order flow which helps you access the object components. To remove the gear drive unit, for example, first find it on the flow and learn its number (21 in this case). You need to remove parts numbered ①, ②, ③, ⑥, ⑪, ⑭, ⑮, and ⑲ so as to access the gear drive unit.
- Unless otherwise specified, the disassembled parts or components should be reassembled in the reverse order of removal.

Disassembly Order Flow

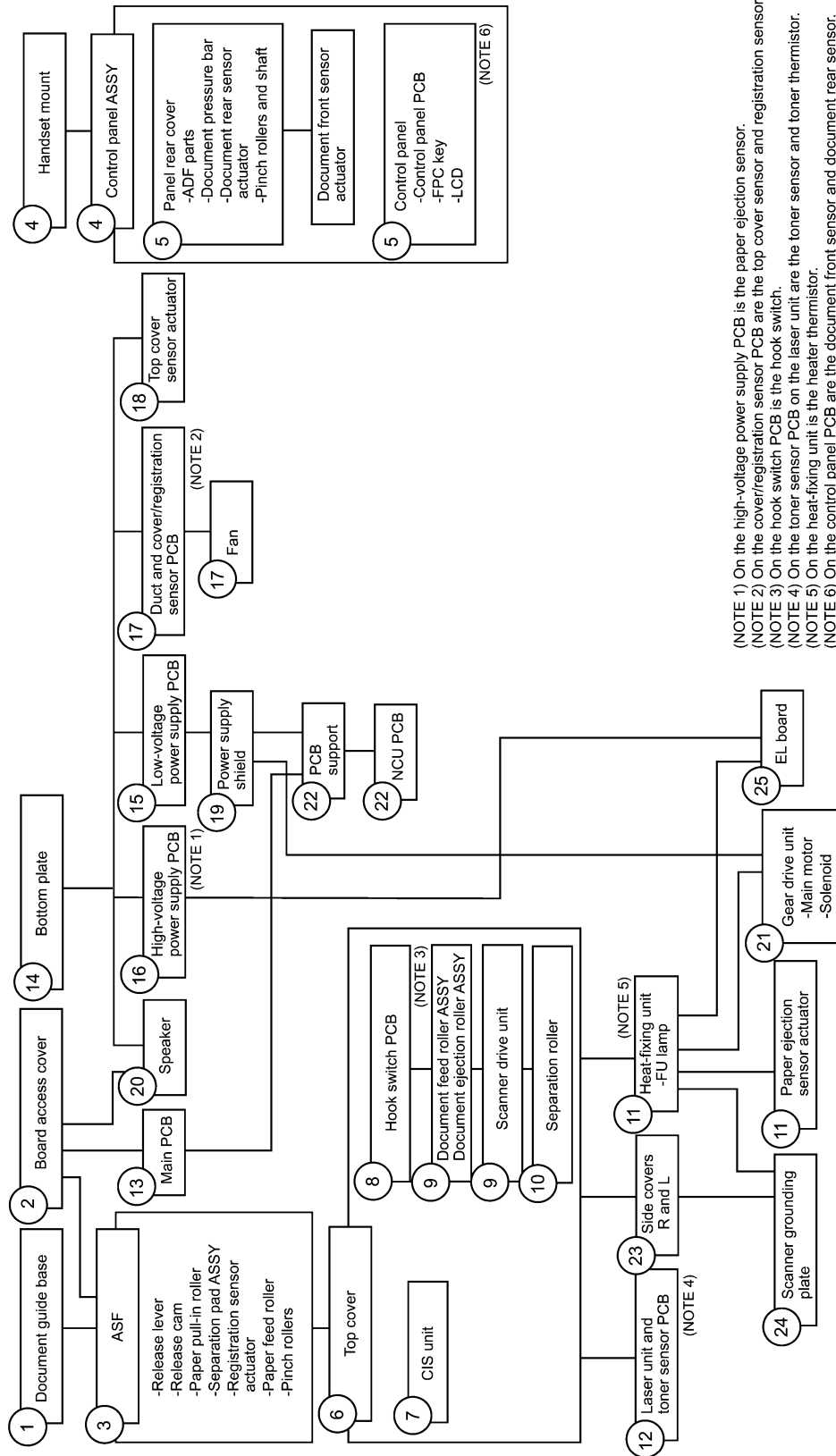

(NOTE 1) On the high-voltage power supply PCB, is the paper ejection sensor.
 (NOTE 2) On the cover/registration sensor PCB are the top cover sensor and registration sensor.
 (NOTE 3) On the hook switch PCB is the hook switch.
 (NOTE 4) On the toner sensor PCB on the laser unit are the toner sensor and toner thermistor.
 (NOTE 5) On the heat-fixing unit is the heater thermistor.
 (NOTE 6) On the control panel PCB are the document front sensor and document rear sensor.

4.1.1 Document Guide Base

- (1) Lift up the document guide base.

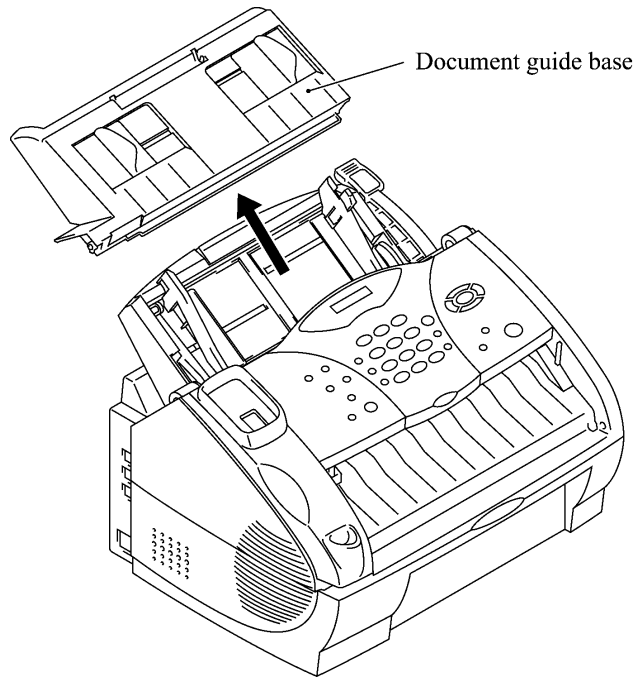

4.1.2 Board Access Cover

- (1) Remove two screws.
- (2) Push down the top of the board access cover to release the two latches from the main cover, then pull it to the rear.

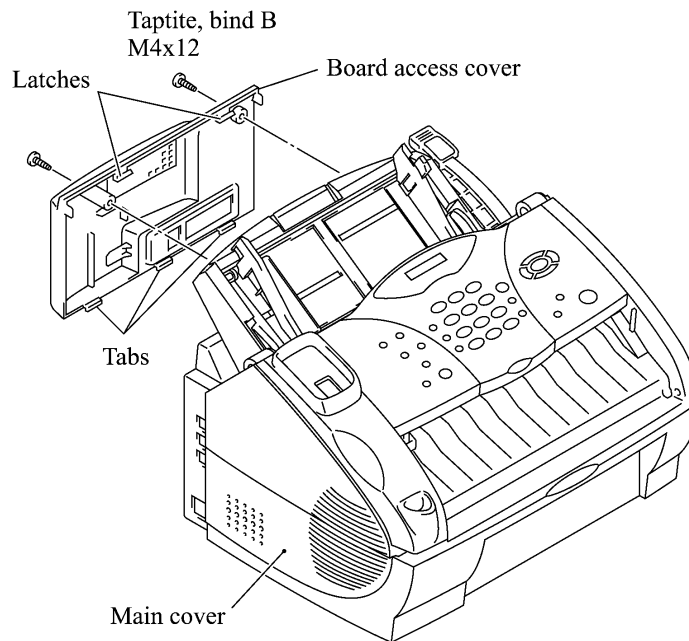

4.1.3 Auto Sheet Feeder (ASF)

- (1) If the board access cover has not been removed in Subsection 4.1.2, you need to remove the two screws with which the board access cover and ASF are fastened together to the main cover.
- (2) Open the top cover.
- (3) Pull the ASF to the front and then lift it up.

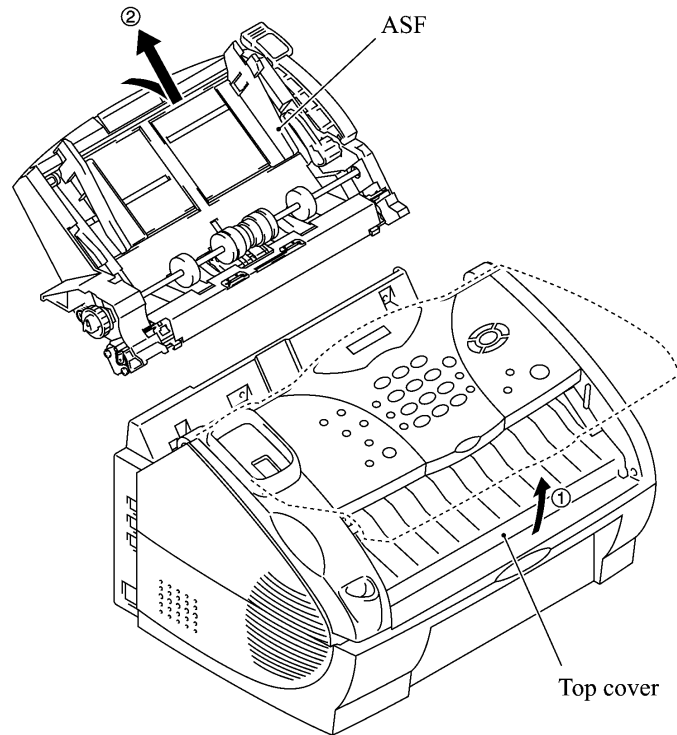

[Disassembling the ASF]

- 1) Unhook the release lever spring.
- 2) Remove screw "a" and pull out the release lever.
- 3) Turn the release cam to the front and pull it out to the left.

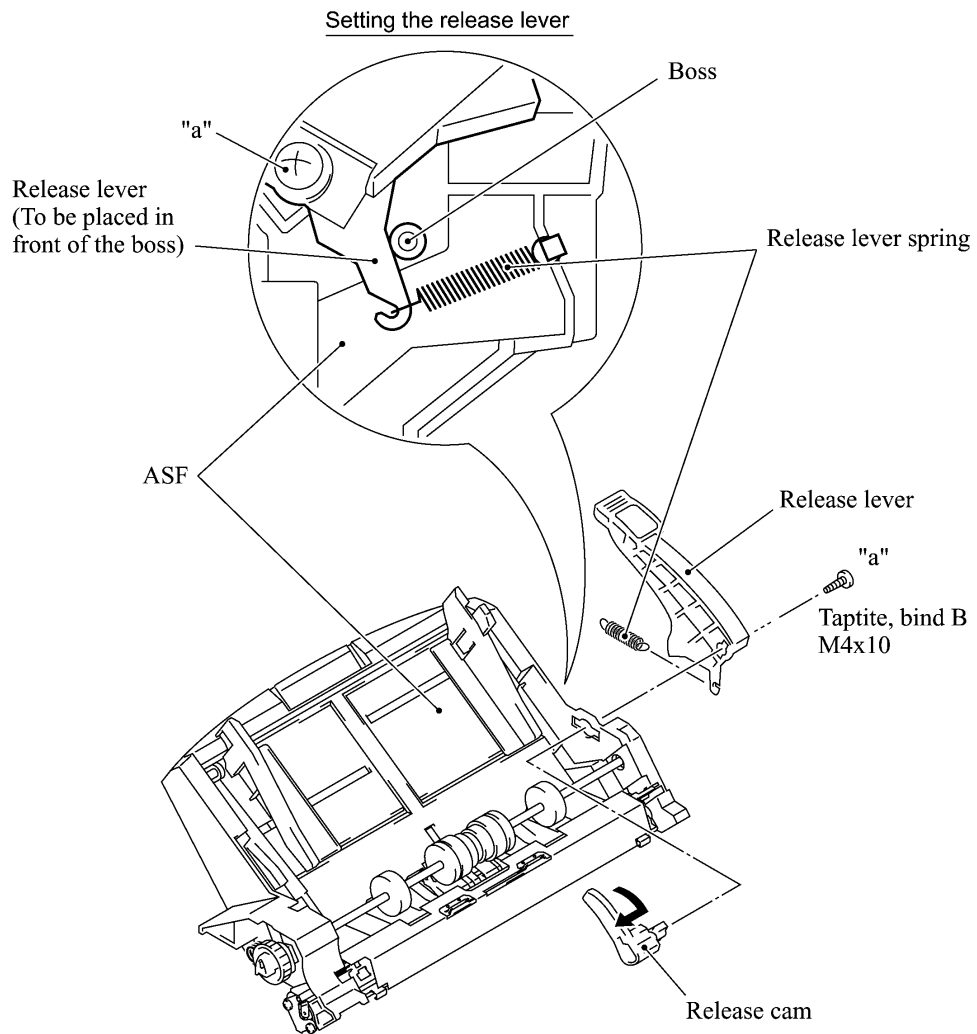

- 4) At the right end of the ASF, remove the screw from the grounding leaf spring R. (It is not necessary to remove the leaf spring.) Next pull out the pawled bushing R.

At the left end of the ASF, remove the sector gear and its spring. Unlatch the pawled bushing L to the left and then remove it from the paper pull-in roller shaft. Remove the paper pull-in roller.

Hooking the sector gear spring

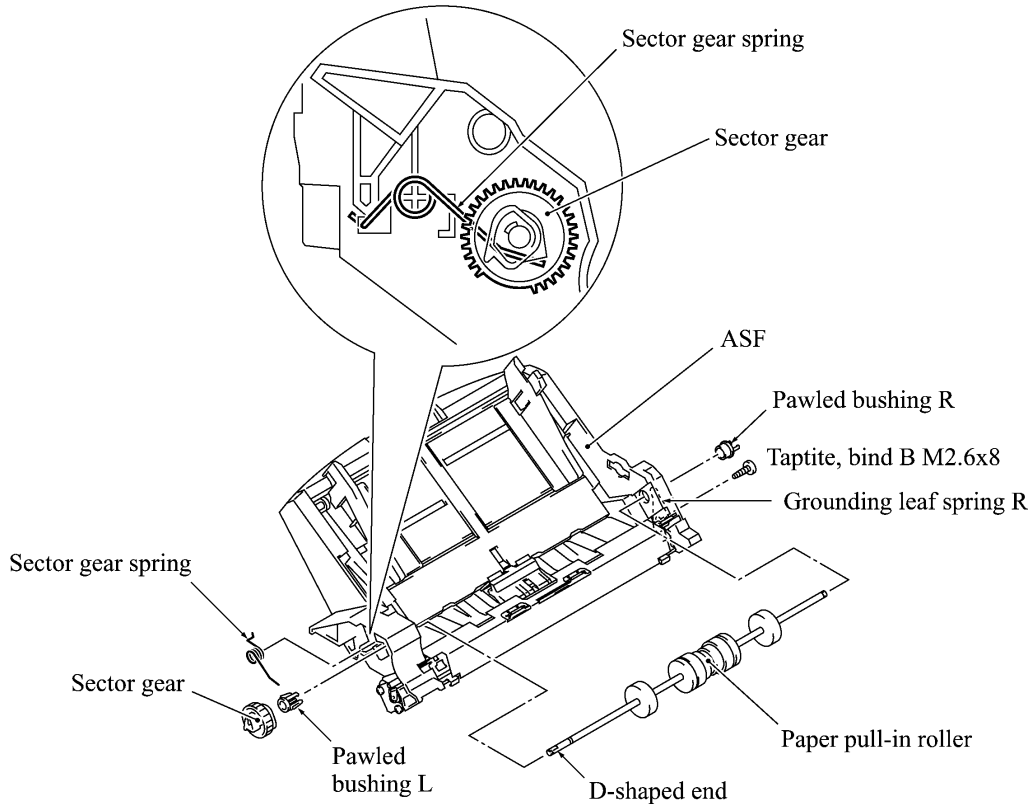

- 5) Push the right and left ends of the separation pad ASSY inwards and take it out. The spring also comes off.

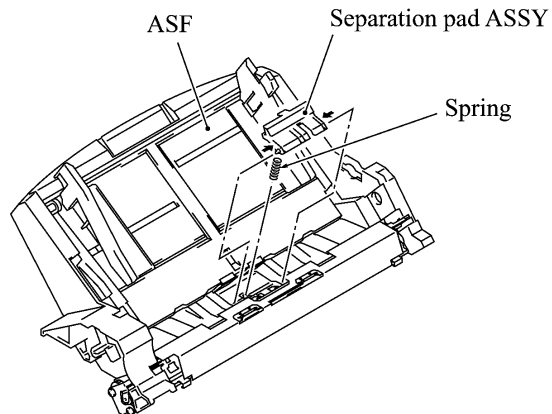

- 6) Turn the ASF upside down, then remove the registration sensor actuator.

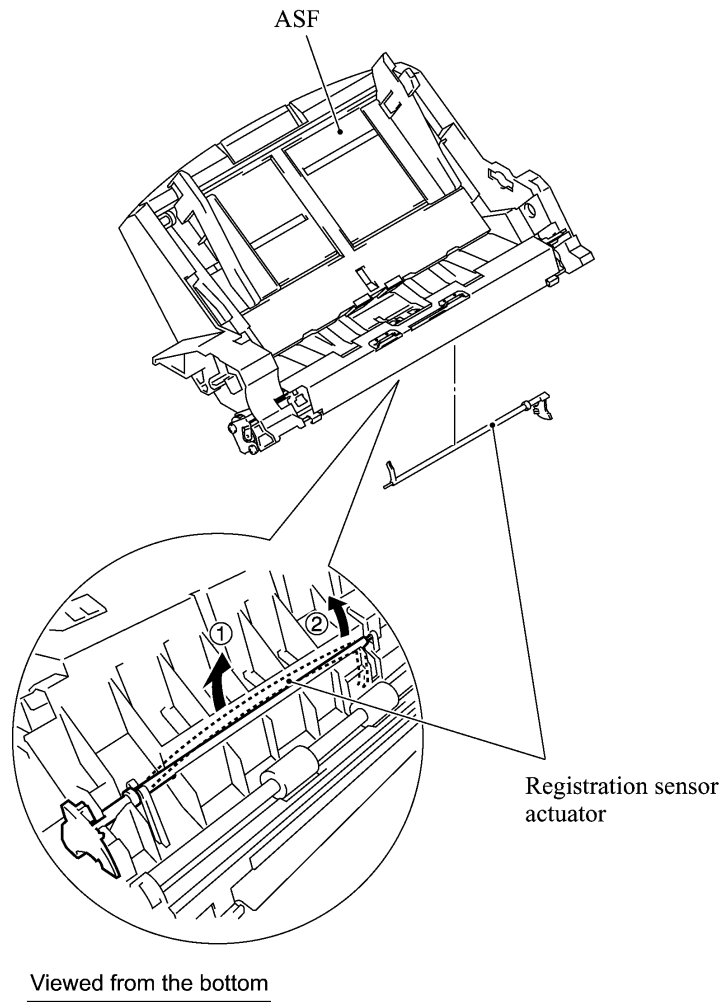

- 7) There are two sets of pinch roller units. At each set, remove the leaf spring (in the order of ① to ③ shown below), pinch rollers, and pinch roller shaft.
 - 8) At the right end of the paper feed roller, remove the screw and take off the grounding leaf spring R if you have not removed it in step 4) above.
 - 9) At the left end of the paper feed roller, remove two screws and take off the grounding leaf spring L, pawled PF gear, and idle gear.
- Then, remove the paper feed roller.

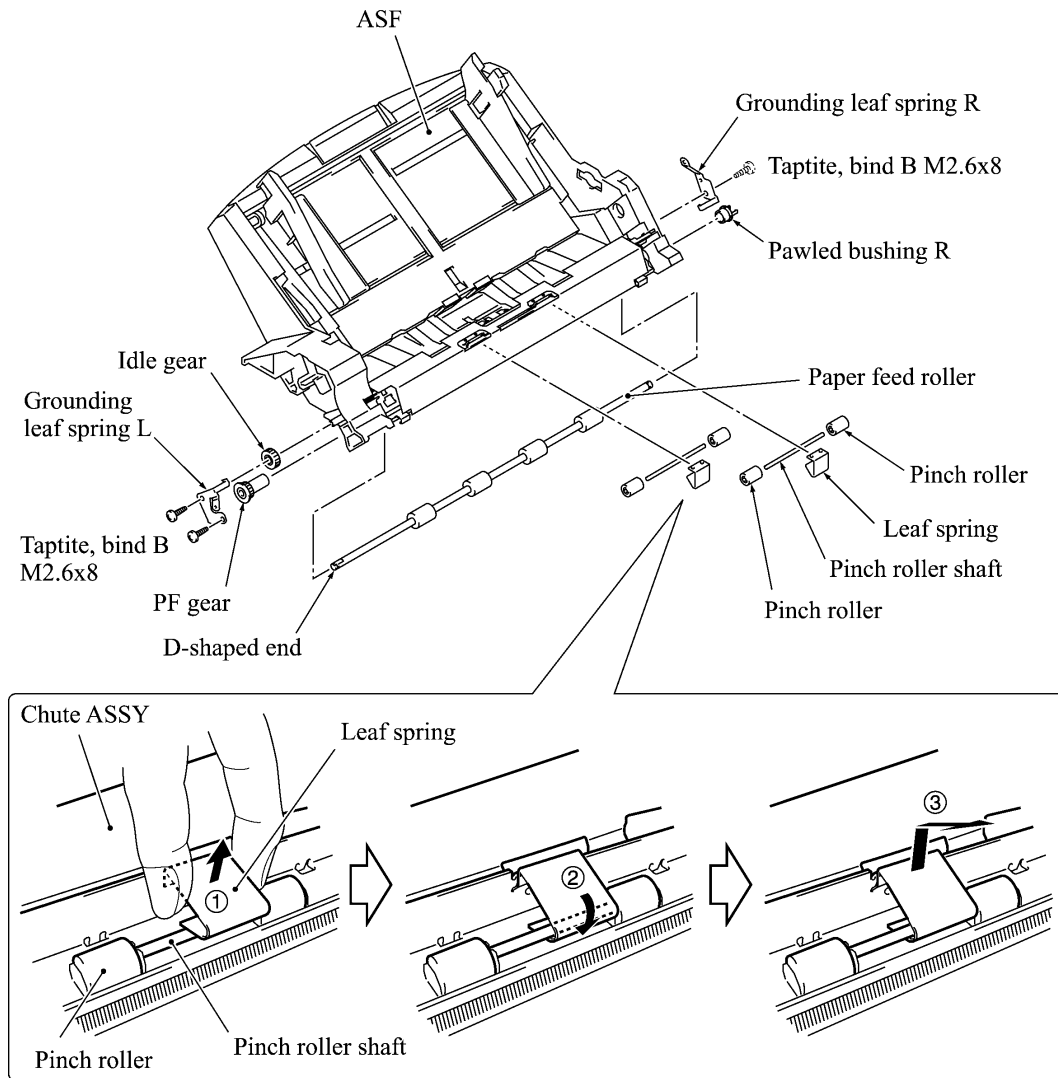

Removing the leaf spring from the pinch roller shaft

- 10) Press the lock arm provided at the left inside of the ASF to the rear with a screwdriver, slide the ASF chute ASSY to the left, and take it out to the front.

NOTE: To replace only the black film attached to the chute, do not remove the ASF chute ASSY from the ASF.

NOTE: A new chute and black film will be provided separately. When replacing the chute ASSY, first set the chute into the ASF and then attach the black film to the chute. If you first attach the black film to the chute and then set the ASF chute ASSY, then the black film may be bent or wrinkled.

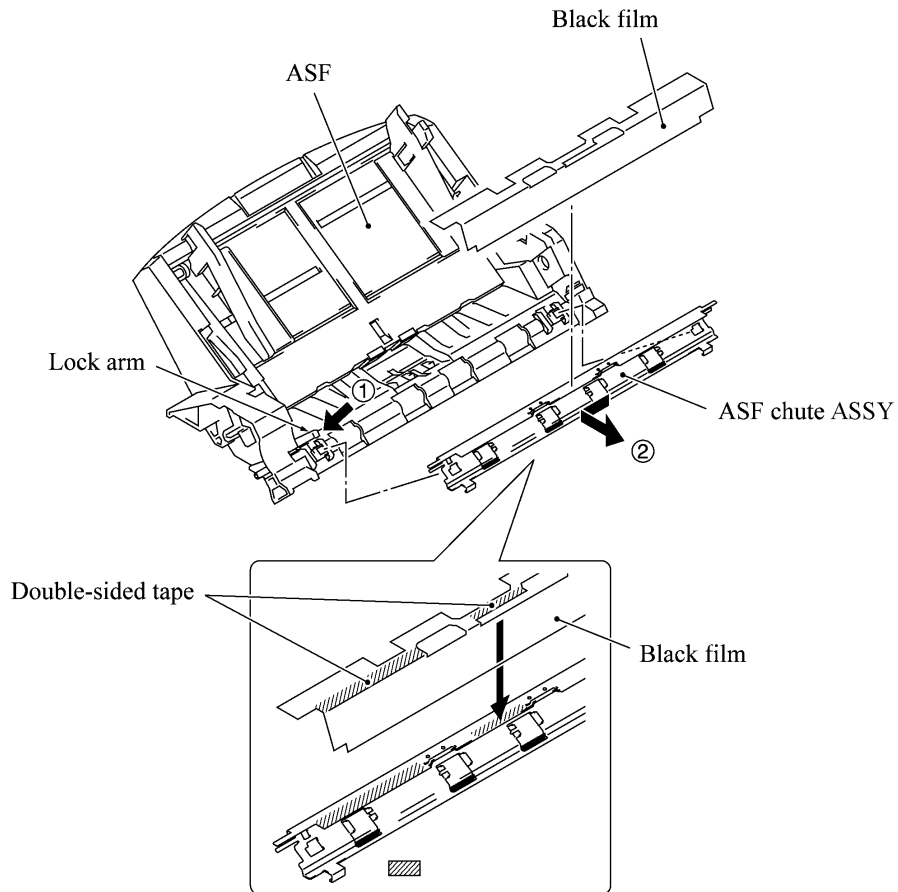

■ Reassembling Notes

- Set the paper feed roller into the ASF with the D-shaped end facing leftwards.
- Set the paper pull-in roller into the ASF with the D-shaped end facing leftwards.
- When setting the release lever back into place, turn the release cam to the rear and then set the release lever so that the bottom end of the release lever comes in the front of the boss provided on the ASF as illustrated on page 4-7.

4.1.4 Handset Mount and Control Panel ASSY

- (1) Open the control panel ASSY.
- (2) Open the top cover.
- (3) Unhook the three latches of the handset mount from the top cover and remove it.

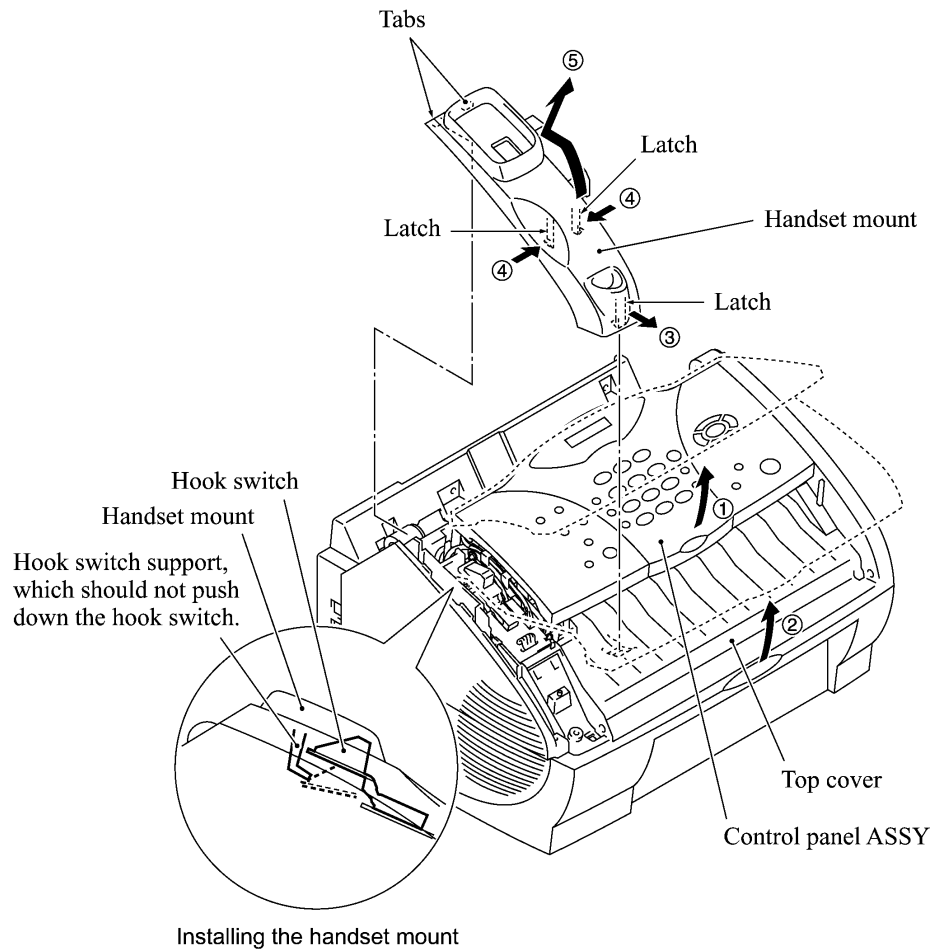

- (4) Disconnect the panel-hook SW harness from the hook sensor PCB and take it out from the cable guides.
- (5) Push the right-hand arm of the control panel ASSY inwards with your finger and open the control panel ASSY further. Then lift up the control panel ASSY.

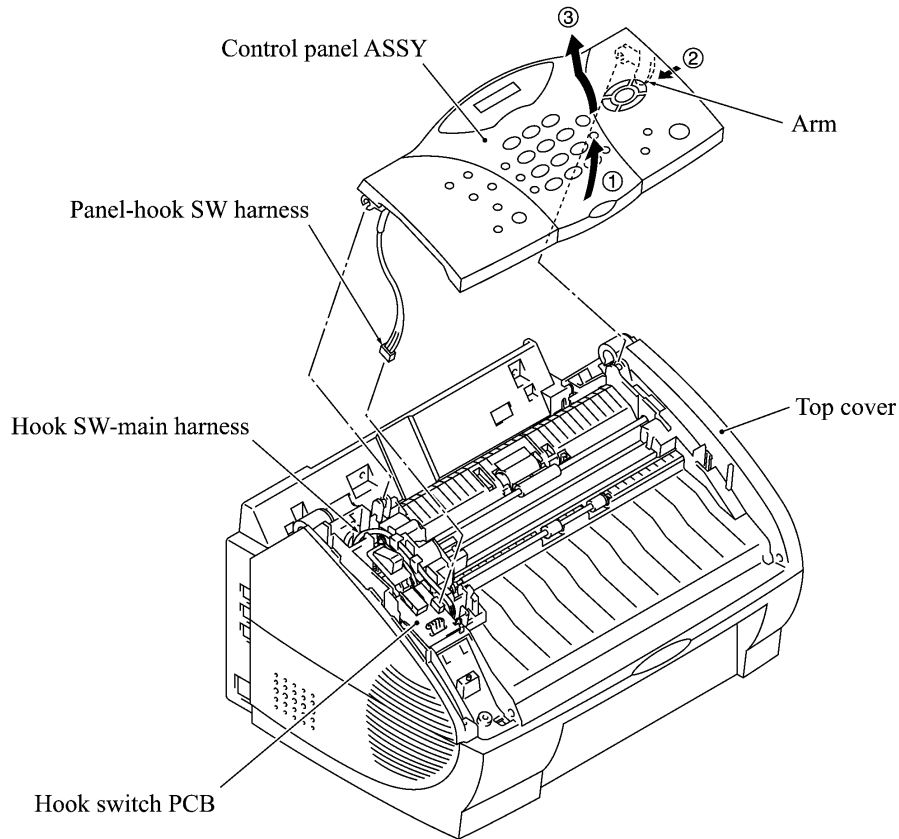

■ Reassembling Notes

- Route the panel-hook SW harness together with the hook SW-main harness through the two cable guides provided on the scanner drive unit, as illustrated in Subsection 4.1.26, "Harness routing B."
- When installing the handset mount, first fit the two tabs provided at the upper section into the top cover and then snap the handset mount into place, taking care not to let it hold down the hook switch.

4.1.5 Panel Rear Cover and Control Panel

- (1) Place the control panel ASSY upside down.

If you do not need to remove the ADF parts, pinch rollers and their related parts, anti-static brush, or document rear sensor actuator, skip to step (6).

- (2) To remove the ADF parts (spring plates and separation rubber), remove the screw.
- (3) To remove the pinch rollers and their related parts, press the lock arm to the rear and shift the pinch roller shaft to the left.
- (4) To replace the anti-static brush, remove it.

NOTE: Once removed, the anti-static brush will become unusable and a new part will have to be put back in.

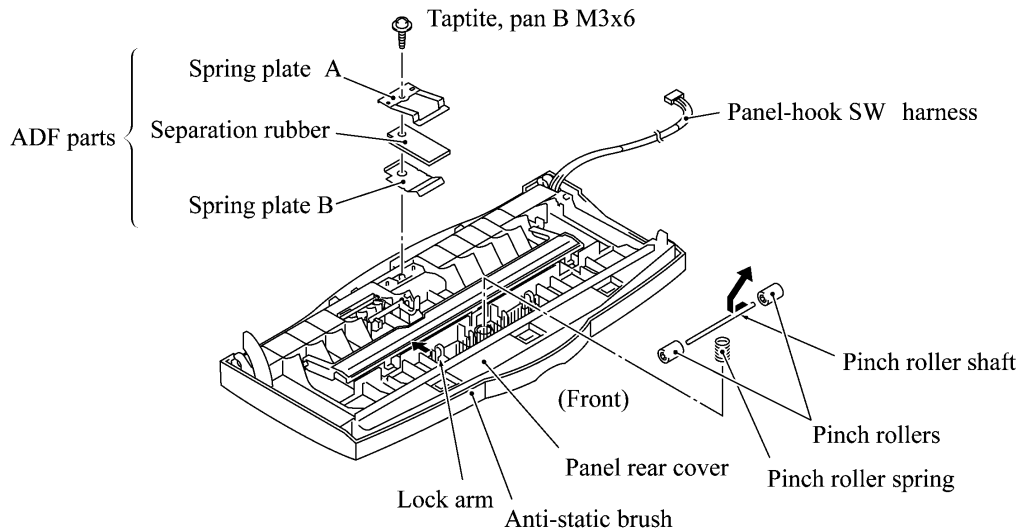

- (5) To remove the document rear sensor actuator, pull support "c" outwards.
- (6) Pull support "a" to the front to release the center tab of the document pressure bar. Next pull either of supports "b" outwards and lift up the document pressure bar. The spring also comes off.

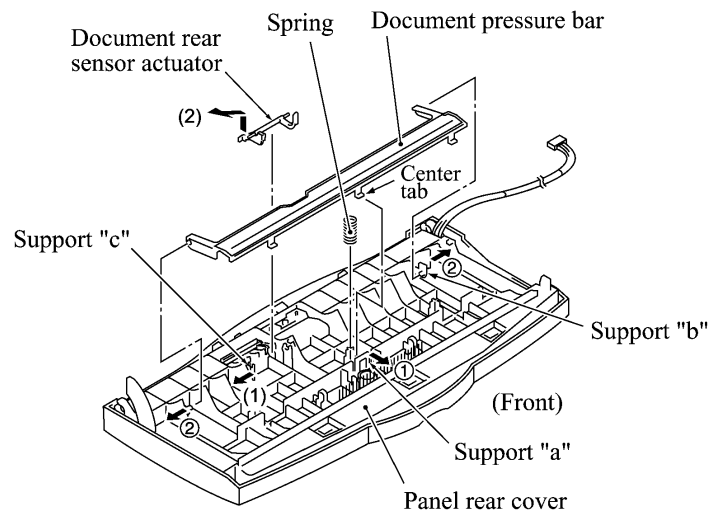

- (7) Remove the two screws from the panel rear cover.
- (8) Unhook the panel rear cover from 10 "X" latches provided on the control panel and take off the panel rear cover.
- (9) Fully turn the document front sensor actuator to the rear and lift it up.
- (10) Unhook the control panel PCB from four "Y" latches.
- (11) Slightly lift up the control panel PCB, then unlock the LCD cable connector and disconnect the LCD flat cable. Next, unlock the FPC key connector and disconnect the FPC key.

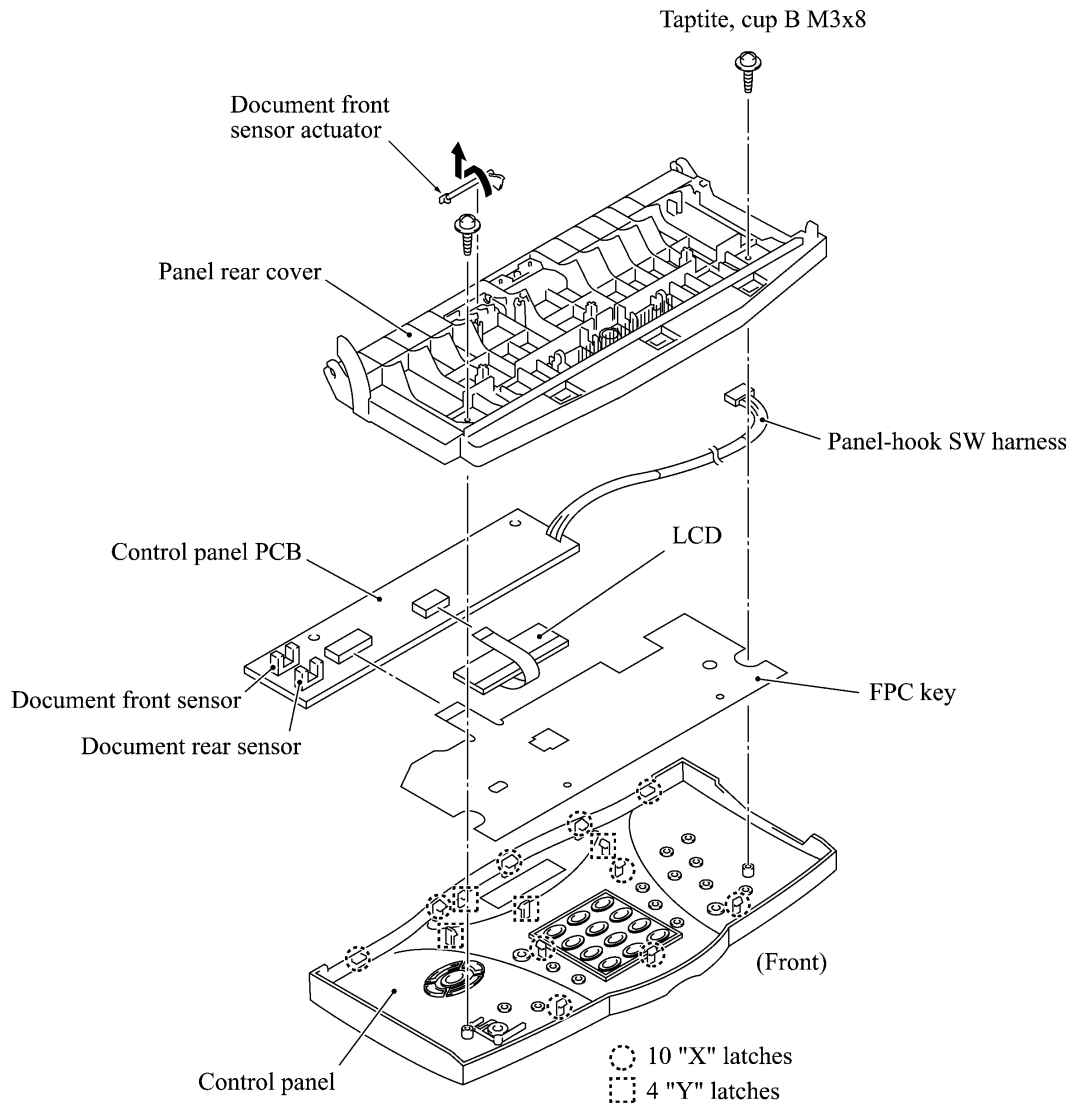

(12) As shown below, pull the clamp outwards to release the LCD and take out the LCD while pulling the LCD flat cable gently.

NOTE: Do not take out the LCD except when the LCD is defective and requires replacement.

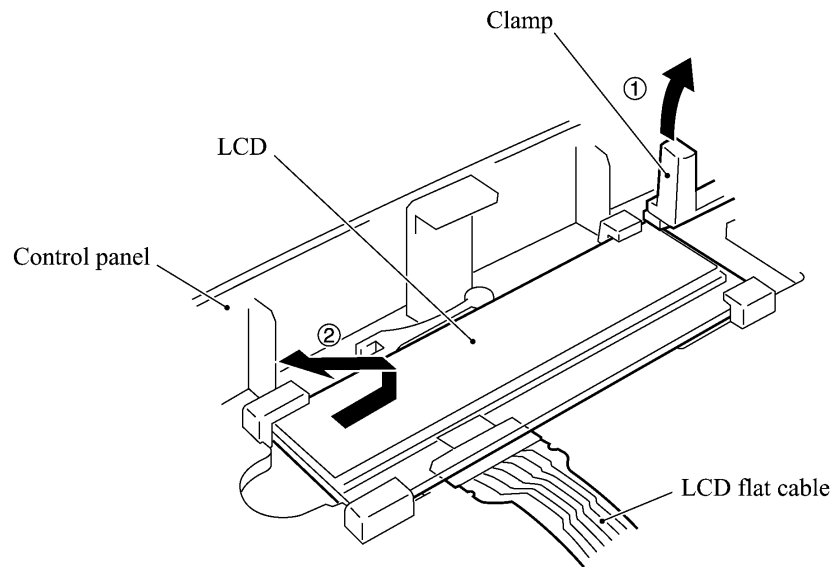

■ Reassembling Notes

- Before reinstalling the LCD to the control panel, wipe fingerprints or dust off the LCD surface and control panel window with a soft cloth.
- A new LCD is covered with a protection sheet. Before installing it, remove the protection sheet.

4.1.6 Top Cover

- (1) Remove the board access cover if installed.
- (2) Disconnect the CIS harness, hook SW-main harness, and scanner motor harness from the main PCB.
- (3) Remove the screw that secures the FG wire to the PCB support.
- (4) Release the hook SW-main harness, scanner motor harness, and FG wire from the two cable guides provided on the main cover. (See Subsection 4.1.26, "Harness routing D.")
- (5) Open the top cover.
- (6) At each of the right and left sides of the top cover, remove the screw from the link stopper. Then pull the link stopper outwards and open the top cover further.
- (7) Turn the top cover upright and then lift it up to the rear.
- (8) Turn each link stopper to the rear and pull it out inwards.

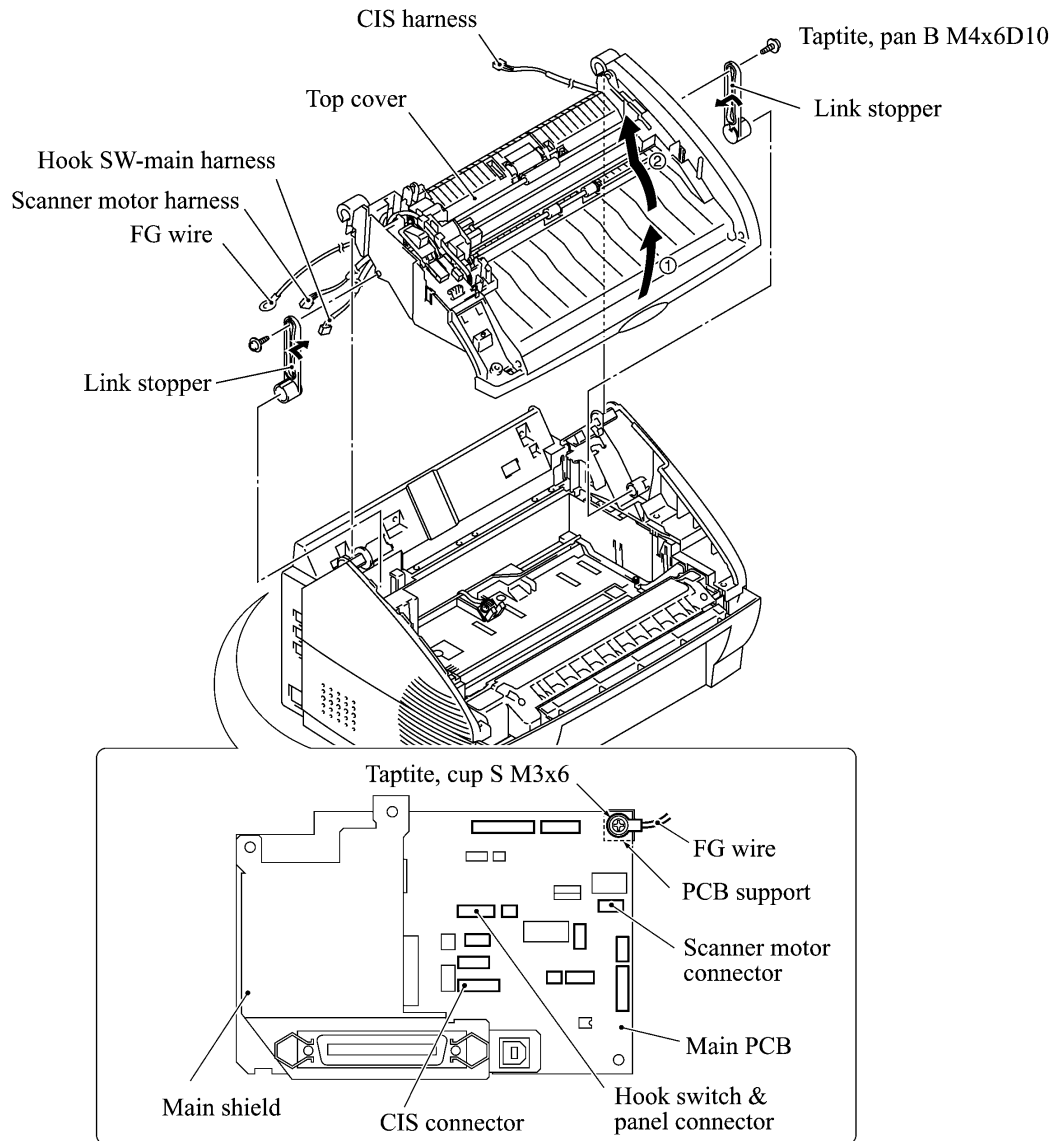

■ Reassembling Notes

- Before reinstalling the top cover, route the FG wire, hook SW-main harness, scanner motor harness, and CIS harness on the underside of the top cover as illustrated in Subsection 4.1.26, "Harness routing C."

After installing the top cover, route the FG wire and those three harnesses on the main cover as illustrated in Subsection 4.1.26, "Harness routing D and E."

- When routing the FG wire, hook SW-main harness, and scanner motor harness through the cable guides, be sure to first route the FG wire and then route those two harnesses. This may prevent the FG wire from working out of the cable guides.
- When disposing of top covers, remove two leaf springs from each top cover with a flat screwdriver to separate *metallic* springs from *plastic* covers.

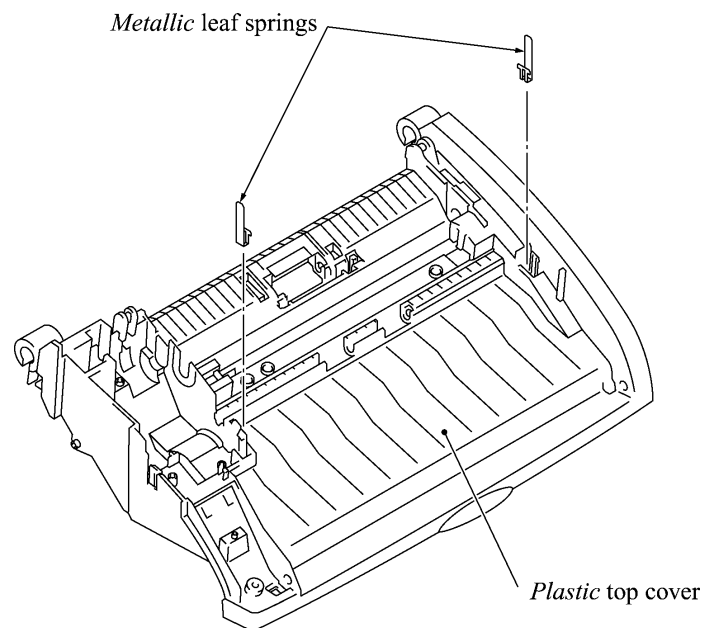

4.1.7 CIS Unit

- (1) Turn the top cover upside down.
- (2) Remove the three screws from the CIS shield plate. The FG wire and feed roller grounding spring also come off.
- (3) Disconnect the CIS harness from the CIS unit.
- (4) Turn the top cover rightside up.
- (5) Slightly pull up the lock arm, move the CIS unit to the left, and lift up the right edge of the CIS unit.
- (6) Remove the two CIS springs.

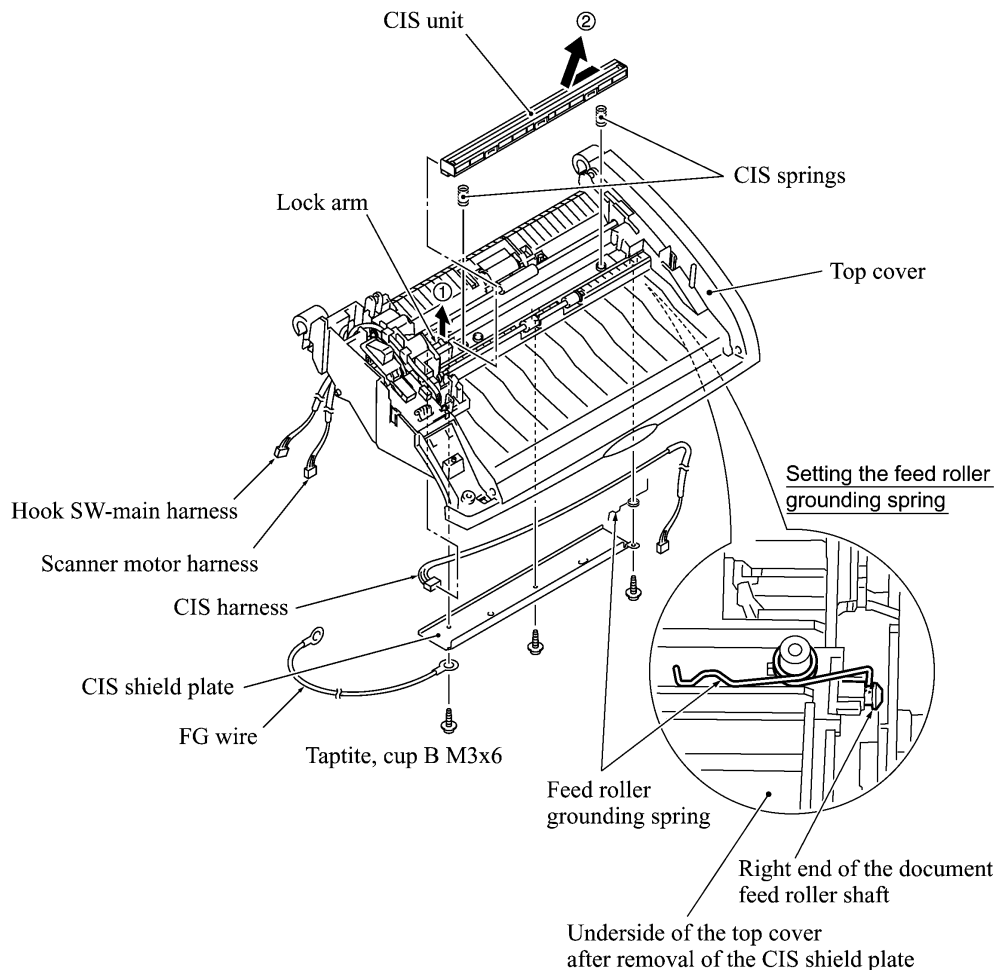

■ Reassembling Notes

- When reinstalling the CIS unit, first insert the left end under the lock arm, put the CIS unit into the top cover, and move it to the right. After installation, wipe fingerprints or dust off the CIS surface with a soft cloth.
- When reinstalling the CIS shield plate, secure it to the top cover together with the feed roller grounding spring and FG wire. The FG wire should be routed as illustrated in Subsection 4.1.26, "Harness routing C."
- Route the CIS harness on the underside of the top cover as illustrated in Subsection 4.1.26, "Harness routing C."

4.1.8 Hook Switch PCB

- (1) From the top cover, unhook the hook switch PCB and take it out.
- (2) Take out the hook SW-main harness from the cable guides provided on the scanner drive unit.

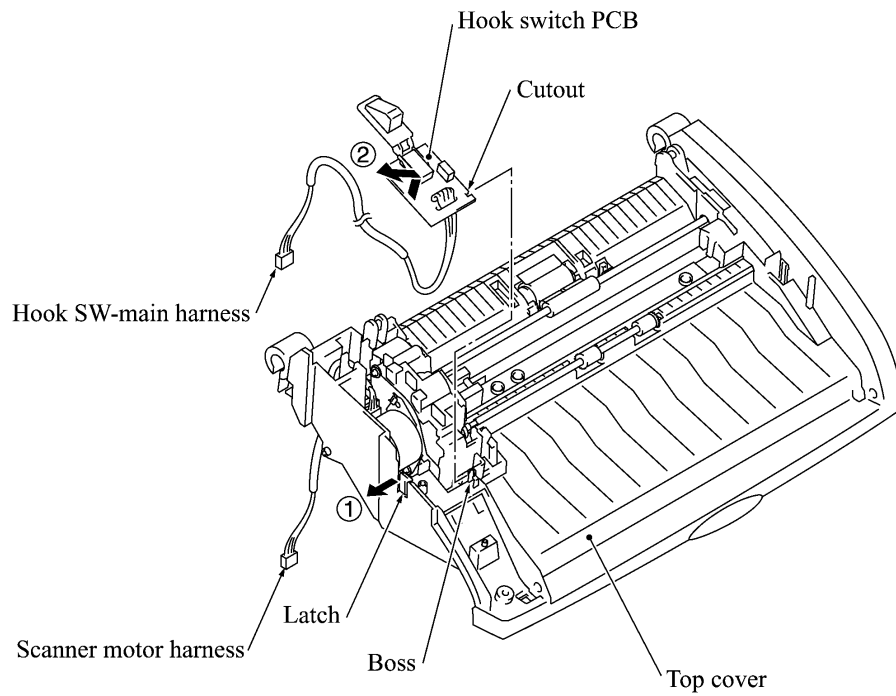

■ Reassembling Notes

- Route the hook SW-main harness through the cable guides provided on the scanner drive unit as illustrated in Subsection 4.1.26, "Harness routing B."

4.1.9 Document Feed Roller ASSY, Scanner Drive Unit, and Document Ejection Roller ASSY

- (1) At the right end of the document feed roller ASSY, unlock the pawled bushing and pull it to the left. Then remove the document feed roller ASSY together with the pawled bushing.
- (2) At the right end of the pressure roller shaft, press the latch to the rear and take out the pressure rollers and their shaft. Then remove the pressure roller springs.

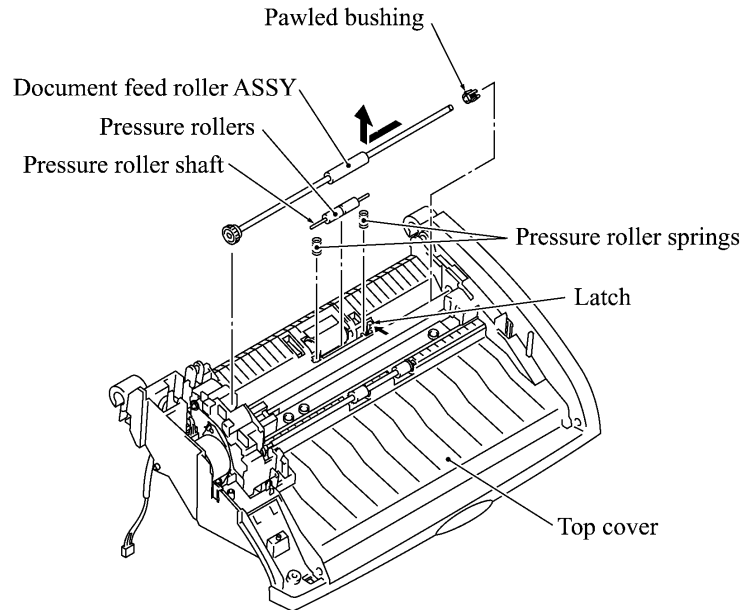

- (3) Remove the two screws from the scanner drive unit.
- (4) Lift up the scanner drive unit together with the document ejection roller ASSY. The bushing also comes off.

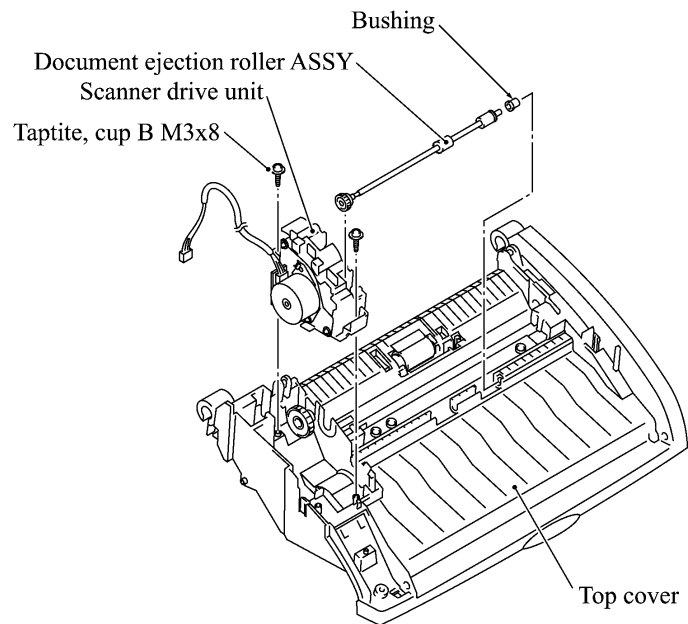

(5) Remove the screw from the scanner motor and take off the motor from the scanner drive unit.

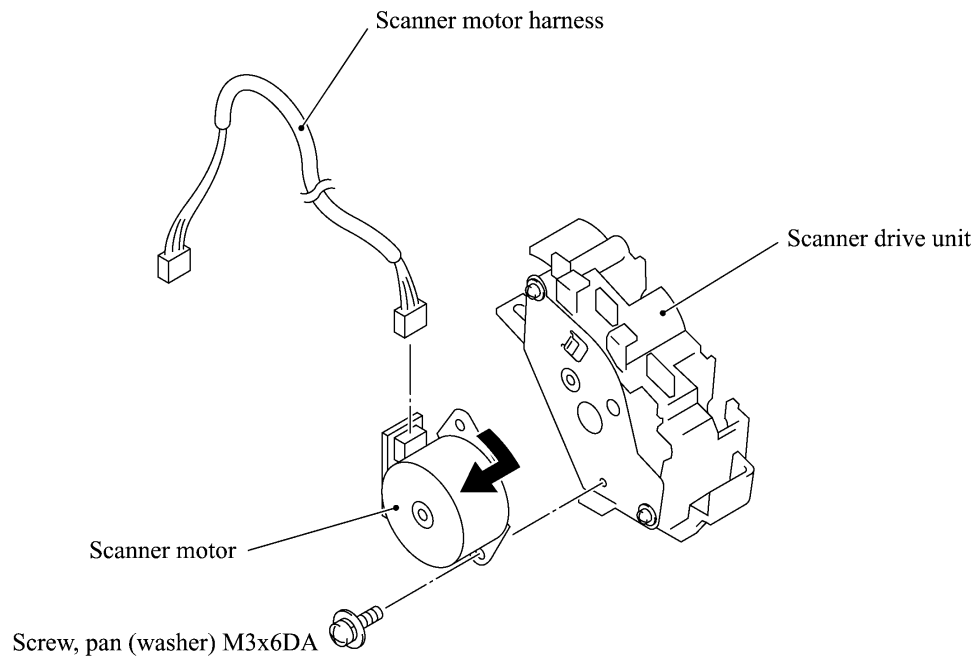

■ Reassembling Notes

- When securing the scanner motor to the scanner drive unit, face the motor connector up as shown above.
- Before putting the scanner drive unit into the top cover, make sure that the stopper of bushing L ("a" in Figure A given on the next page) faces up when viewed from the top. Then move bushing L to the right to fit it in the cutout provided in the top cover.
- Before securing the scanner drive unit to the top cover with two screws, set the document ejection roller ASSY into place.

4.1.10 Separation Roller and its Gear

- (1) Turn the top cover upside down. Place the top cover with its rear edge facing towards you.
- (2) Slightly push down the lock arm and move the separation roller gear to the left together with its bushing L ("a" in the illustration given below). Then take them out from the top cover.
- (3) Move the separation roller to the left and take it out together with its bushing S ("b").
- (4) Slightly push down the lock arm again and remove the bushing L ("c") to the left.

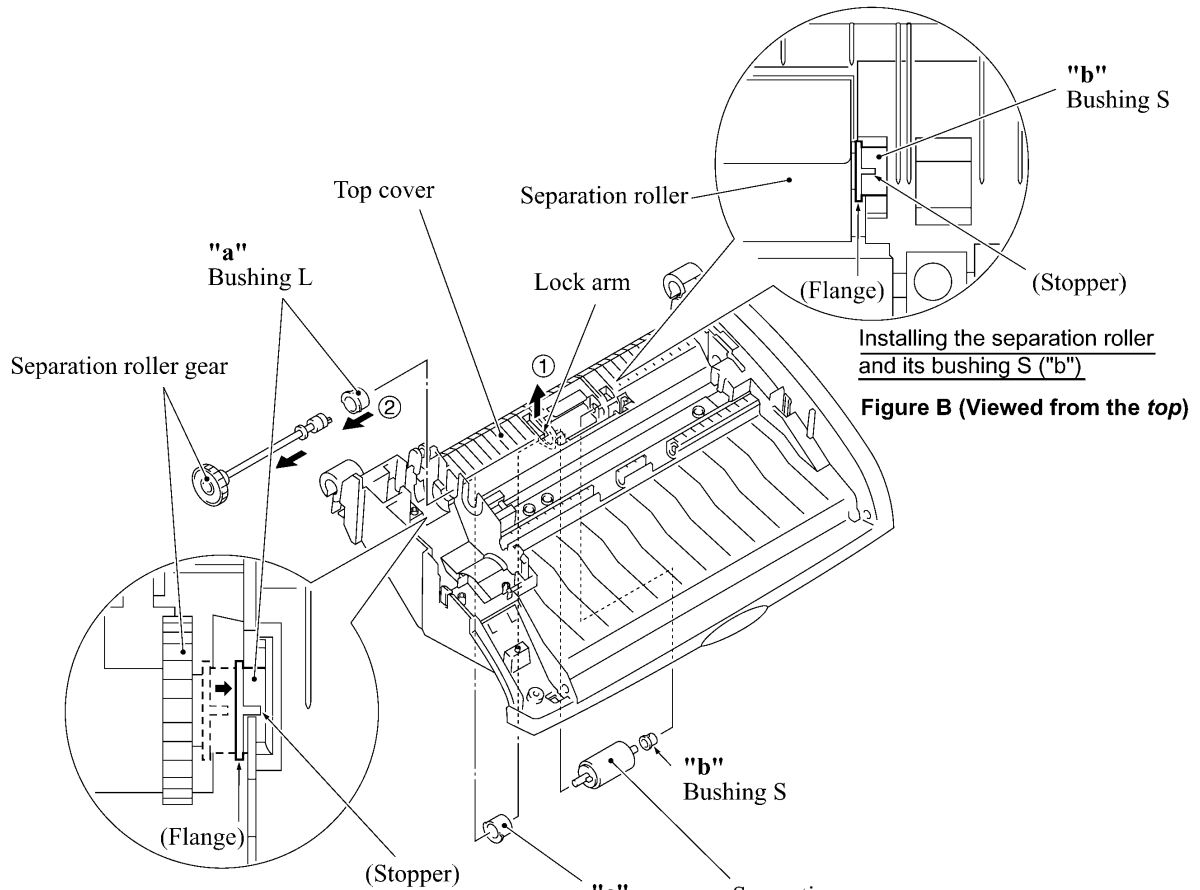

Figure B (Viewed from the top)

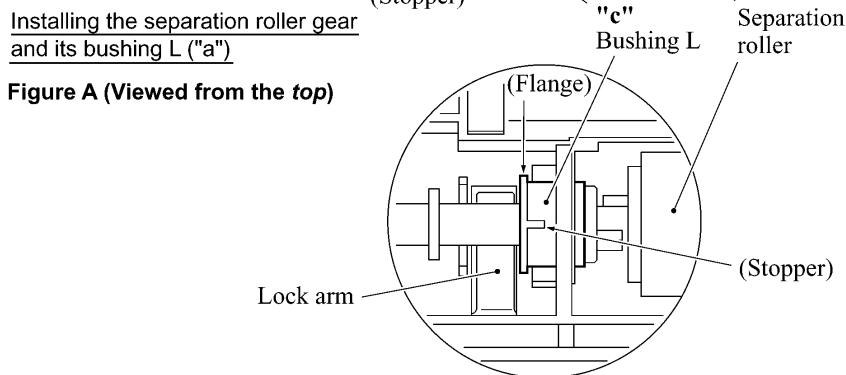

Figure A (Viewed from the top)

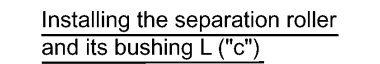

Figure C (Viewed from the bottom)

■ Reassembling Notes

- The separation roller and its related parts use three bushings (two bushings L and one bushing S). When fitting those bushings, be careful with the direction of their flanges and stoppers as shown on the previous page.

What follows is the installation procedure of the separation roller and its related parts.

- 1) Turn the top cover *upside down*. Place the top cover with its rear edge facing towards you.
- 2) Lightly push down the lock arm and fit bushing L ("c") to the top cover with its flange facing to left and with its stopper facing up. (See Figure C on the previous page.)
- 3) Set bushing S ("b") onto the separation roller shaft with its flange facing towards the roller. First insert the left end of the roller shaft into bushing L ("c") and then insert the right end to the top cover with the stopper of bushing S ("b") facing down. (See Figure B.)
- 4) Set bushing L ("a") onto the separation roller gear shaft with its flange facing towards the gear. Insert the right end of the gear shaft through the cutout provided in the top cover and engage it with the separation roller shaft.

Make sure that the separation roller gear is locked by the lock arm.

- 5) Turn the top cover to the normal position. Move bushing L ("a") to the right so that it will be fitted to the cutout provided in the top cover with its stopper facing up when viewed from the top. (See Figure A.)

- Once removed, the separation roller film will become unusable and new one will have to be put back in. When attaching a new film, align its left and top edges with the left and top edges of the recessed section as illustrated below. In particular, take care not to let the film override the rear edge of the recessed section.

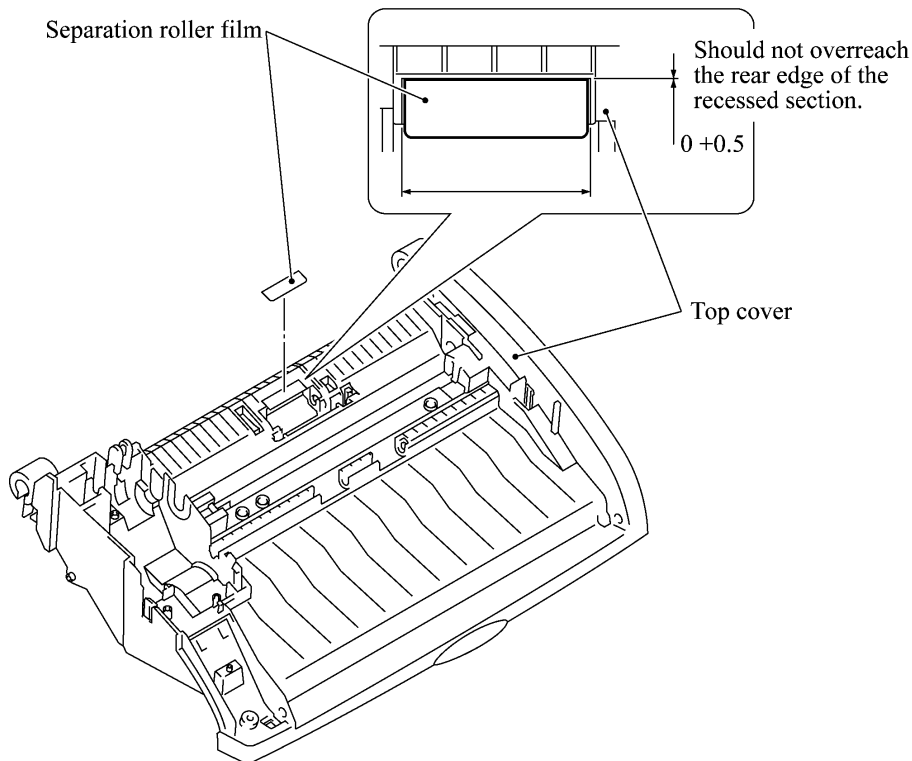

4.1.11 Heat-fixing Unit, FU Lamp, and Paper Ejection Sensor Actuator

- (1) Remove the two screws from the heat-fixing unit.
- (2) Lift up the heat-fixing unit and disconnect the blue and brown heater wires (of the heater harness) from the heat-fixing unit. Then disconnect the heater thermistor harness from the EL (eraser lamp) board.
- (3) Remove the paper ejection sensor actuator from the bottom of the heat-fixing unit.

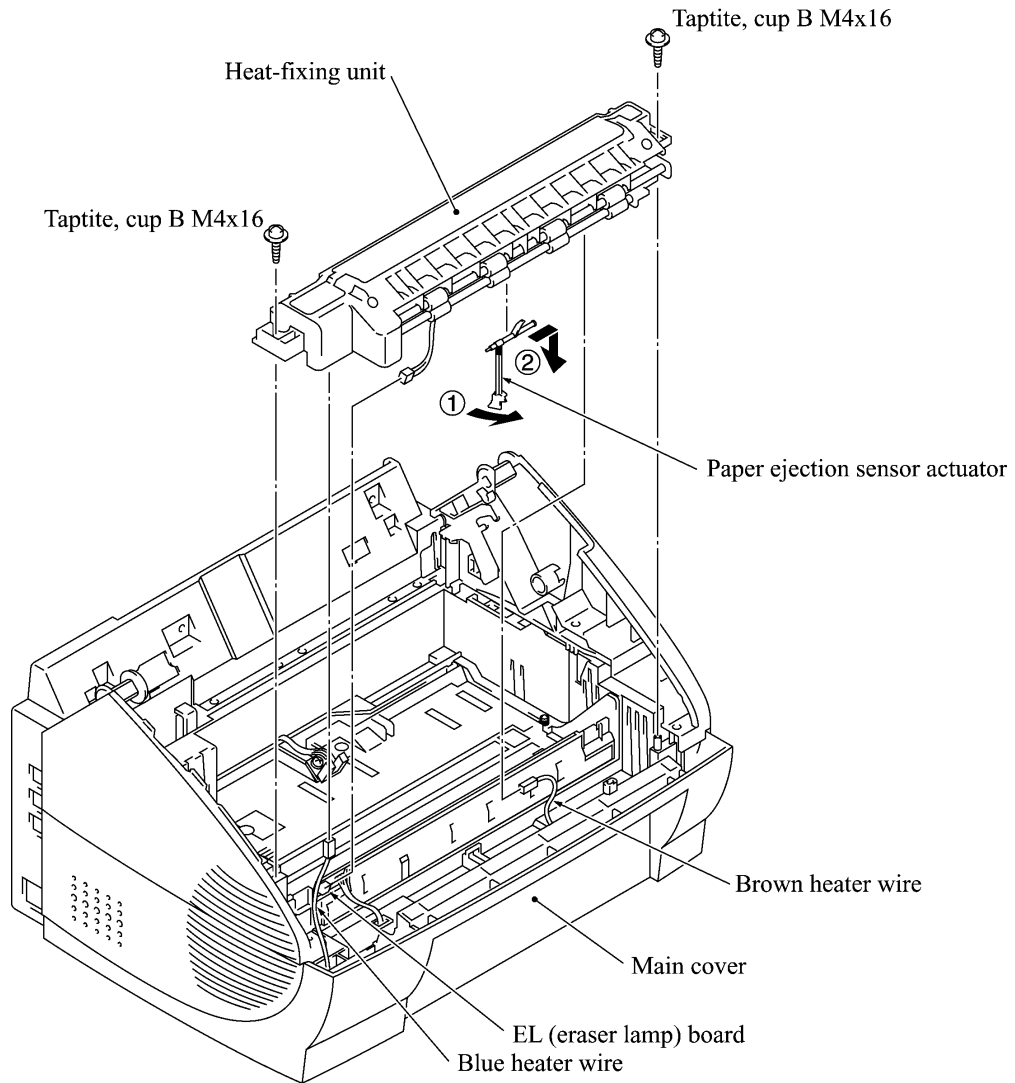

- (4) To take out the FU lamp from the heat-fixing unit, remove two screws "a."
- (5) Fully open the upper cover and remove it.
- (6) Unlatch the idle gear 16 and remove it.
- (7) Loosen screw "b."
- (8) Remove screw "c" and take out the lock plate.
- (9) Slightly lift up the left end of the heater roller and hold the left end of the FU lamp. While pinching the fuse plate R with your right hand, pull out the FU lamp from the heater roller.

CAUTION: Do not touch the FU lamp. If you have touched it, clean it thoroughly with alcohol.

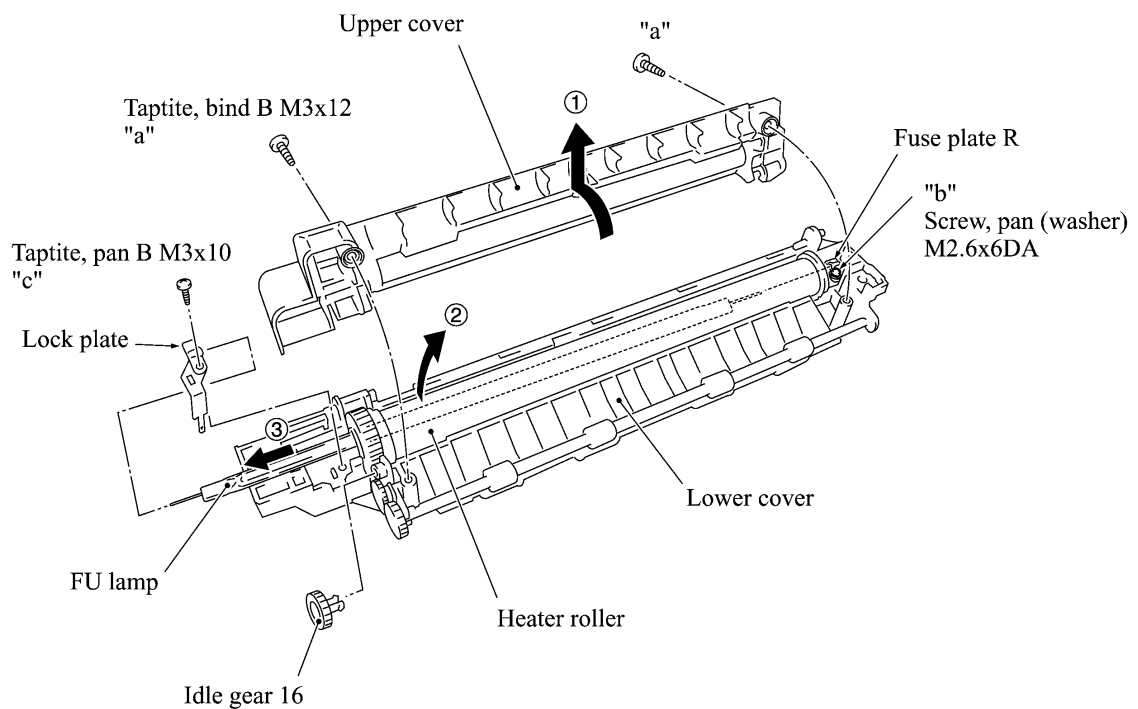

■ Reassembling Notes

- When setting the FU lamp into the heat-fixing unit, be sure to insert the right edge of the wire into the folded fuse plate R.
- A new heat-fixing unit will be provided with the heater thermistor harness being taped to the unit. When installing the unit, remove the tape.
- Route the blue and brown heater wires on the main cover as illustrated in Subsection 4.1.26, "Harness routing F."

4.1.12 Laser Unit and Toner Sensor PCB

- (1) Disconnect the polygon motor flat cable, toner sensor harness, and laser diode harness from the main PCB.
- (2) Remove the three screws from the laser unit.
- (3) Lift up the laser unit.

NOTE: When handling the laser unit, take care not to touch the inside of the unit, glass, or mirror.

NOTE: On the small PCB at the right side of the laser unit is a 2-pin connector which is for the adjustment in the factory. Do not disturb it.

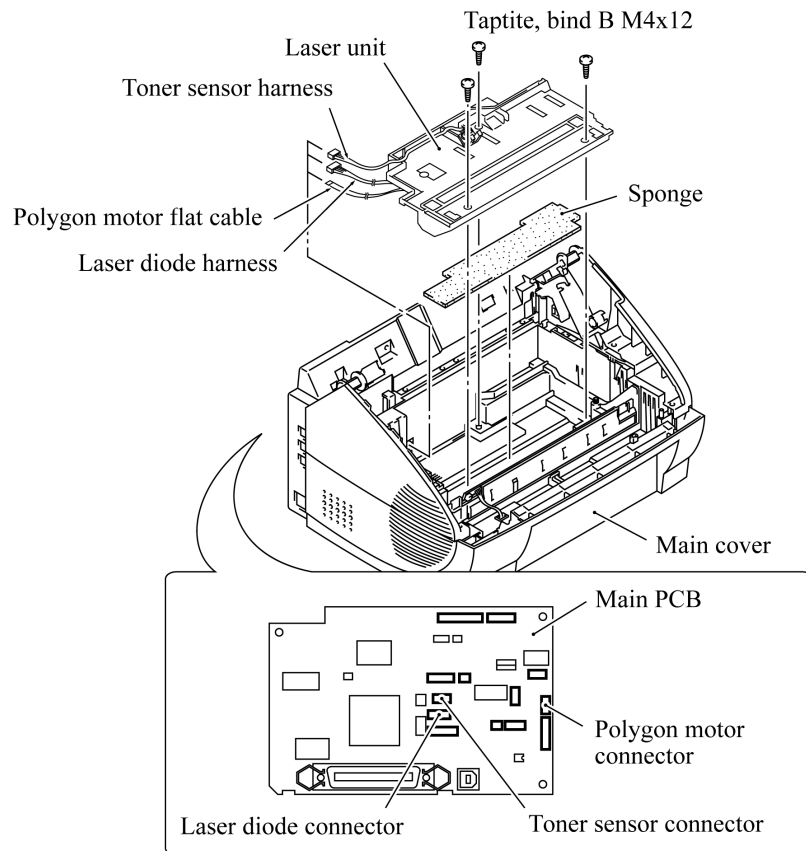

■ Reassembling Notes

- On the underside of the laser unit, route the laser diode harness, polygon motor flat cable, and toner sensor harness as illustrated in Subsection 4.1.26, "Harness routing G."
- Before putting the laser unit back into place, check for any toner particles, paper dust or dirt, and clean them out.
- Make sure that the sponge is placed below the laser unit.

4.1.13 Main PCB

- (1) Disconnect the following harnesses and flat cable from the main PCB:
 - NCU harness
 - Low-voltage power harness
 - Main motor harness
 - High-voltage power flat cable
 - Cover/registration sensor & fan harness
 - Solenoid harness
 - Speaker harness
- (2) Remove two screws "a" from the main shield.
- (3) Remove two screws "b" from the parallel interface connector.
- (4) Remove two screws "c" from the main PCB and then take it off from the PCB support. (The upper one of these screws has been removed to release the FG wire when you have removed the top cover in Subsection 4.1.6.)

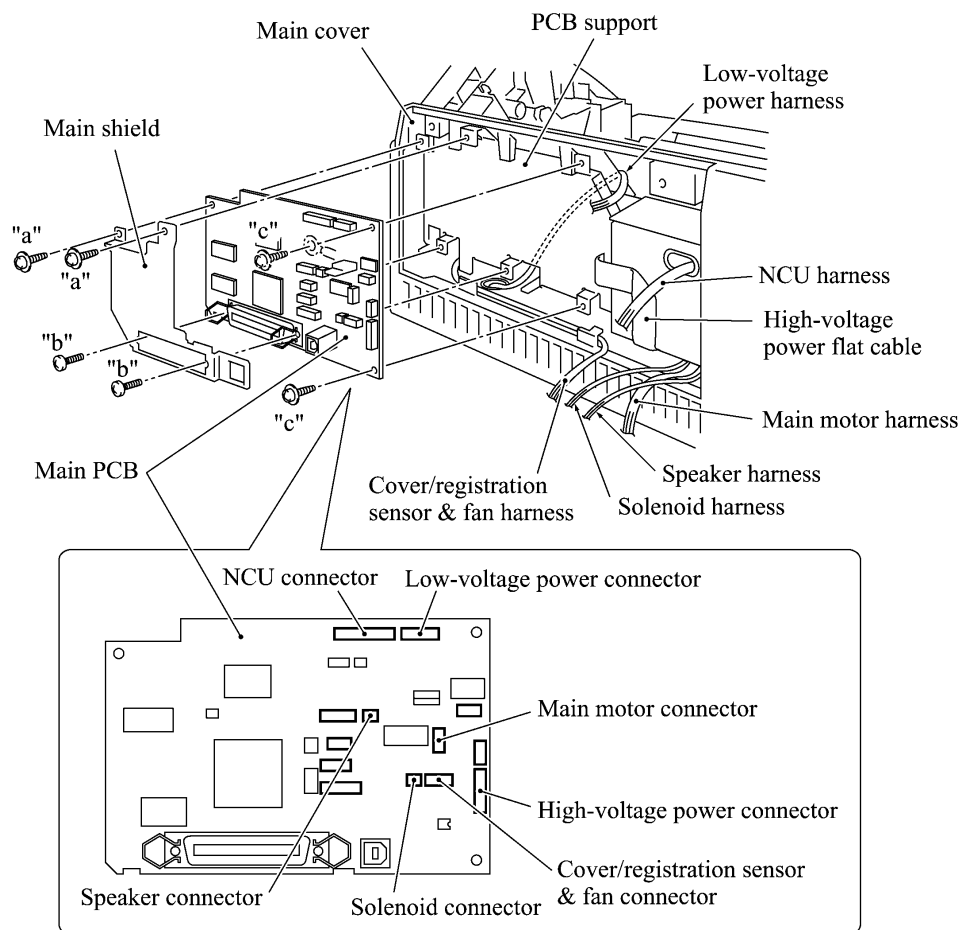

"a" and "c": Taptite, cup S M3x6
"b": Taptite, pan S M3x12

■ Reassembling Notes

- Be sure to route the harnesses and flat cable as illustrated in Subsection 4.1.26, "Harness routing A."
- After you replace the main PCB, be sure to follow the flowchart given on the next page.

Setting up the main PCB after replacement

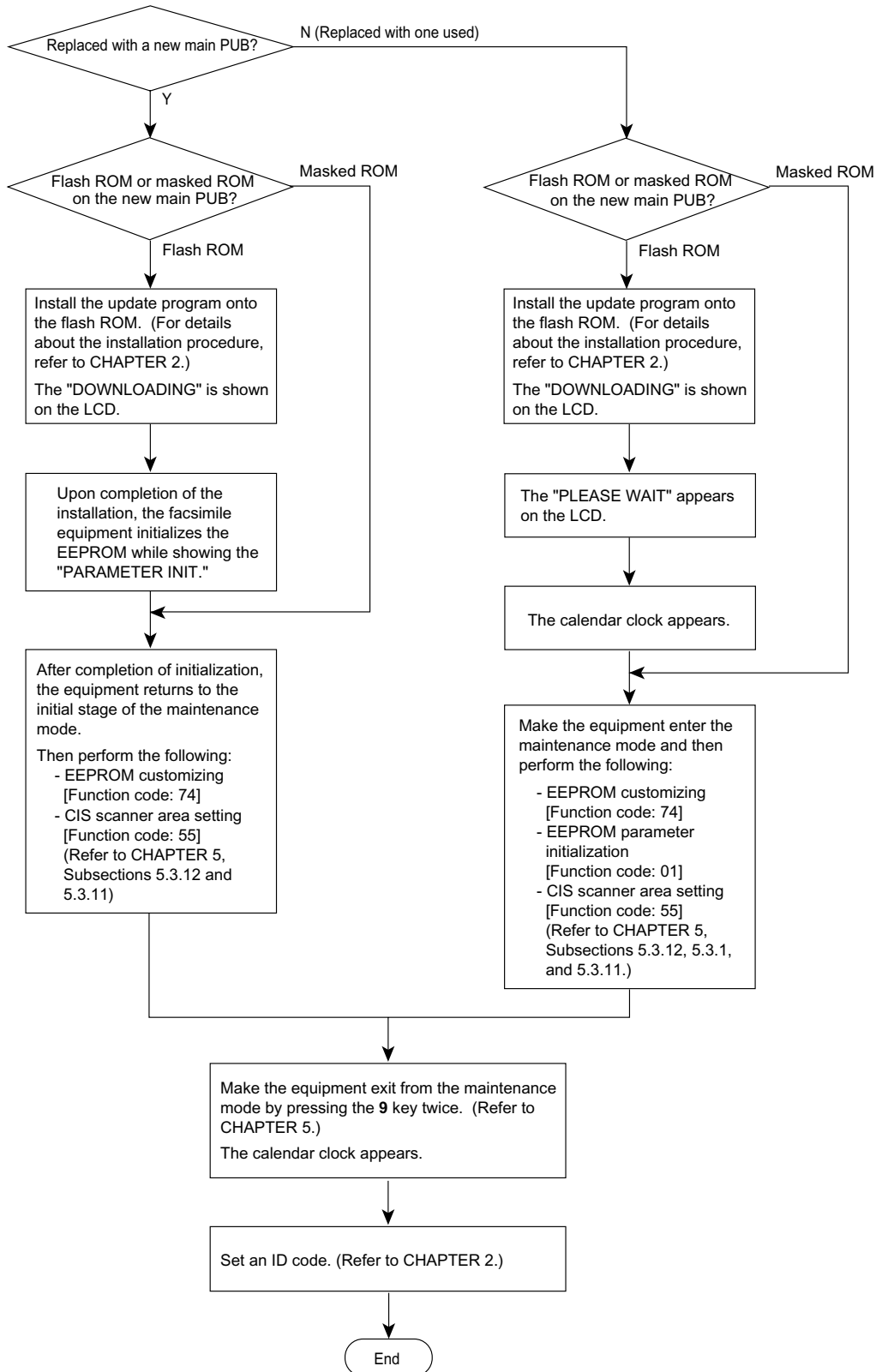

4.1.14 Bottom Plate

- (1) Turn the machine upside down.
- (2) Remove the nine screws (four "x" and five "y") from the bottom plate, then lift it up.

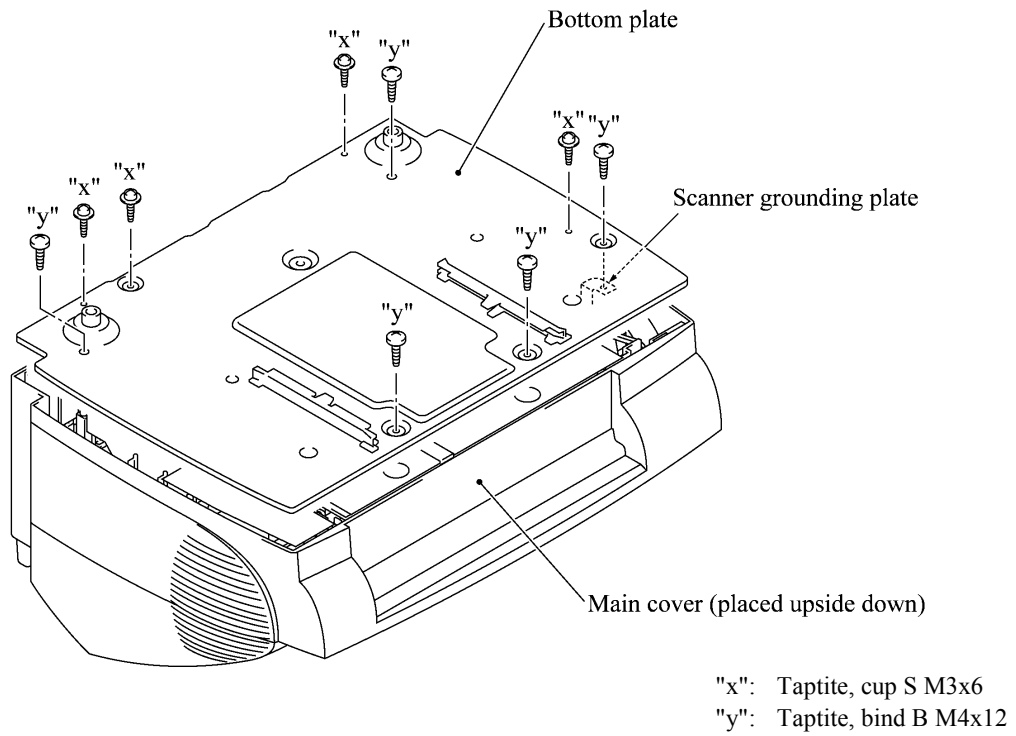

4.1.15 Low-voltage Power Supply PCB

- (1) Remove screw "a" and take off the low-voltage insulator sheet.
- (2) Remove screws "b" and "c" from the low-voltage power supply PCB and grounding wire, respectively.
- (3) Remove screw "d" and lift up the power inlet support.
For the new type of the power inlet support having an opening: You need to cut off the binder that fastens the blue and brown lead wires of the AC power cord to the power inlet support.
- (4) Slightly lift up the low-voltage power supply PCB and disconnect the low-voltage power harness and heater harness (of the blue and brown wires).

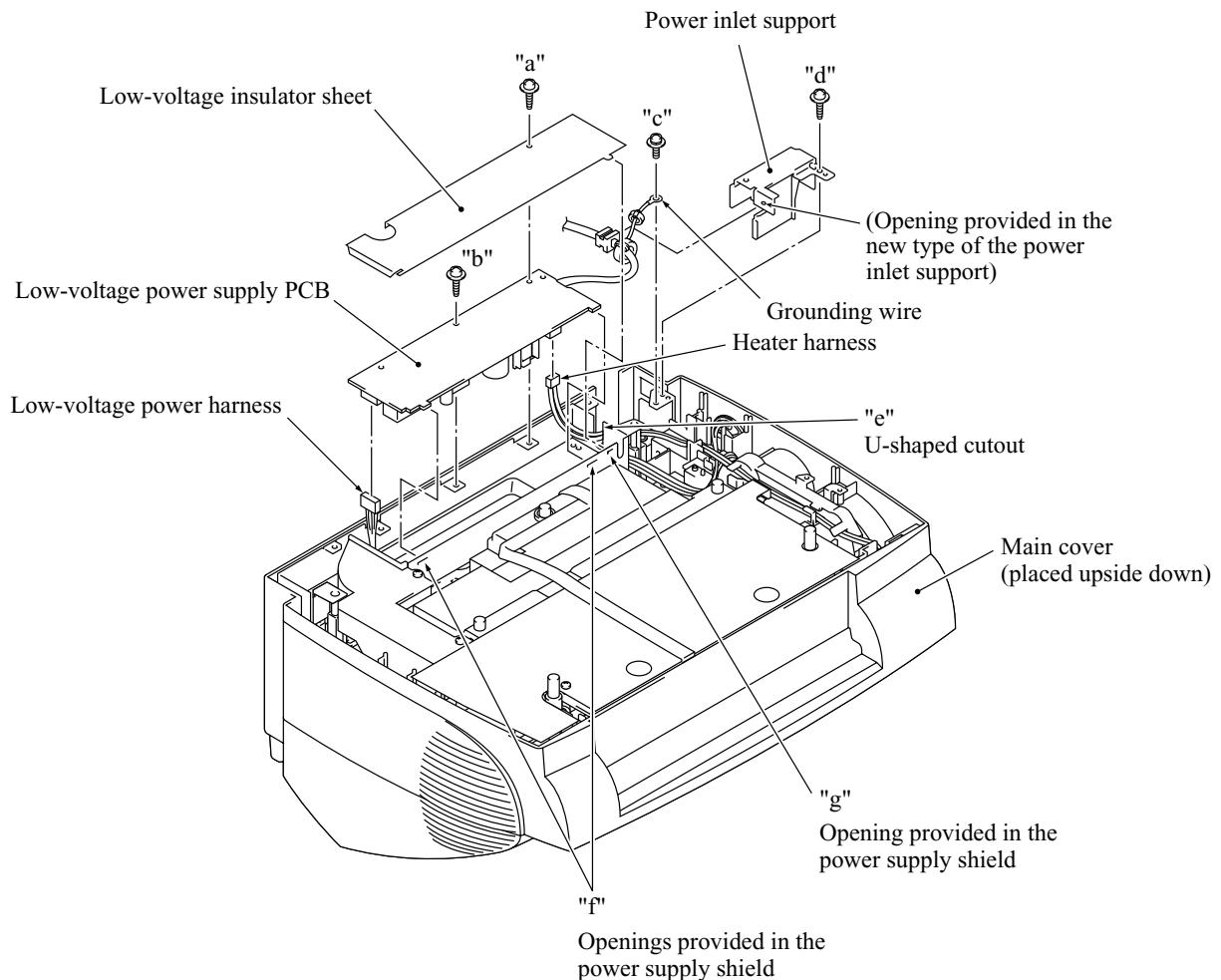

"a," "b," and "d": Taptite, cup S M3x6
"c": Screw, pan (washer) M4x8DB

■ Reassembling Notes

- Be sure to route the heater harness through U-shaped cutout "e" provided in the power supply shield. Then, route the AC power cable through the same cutout "e" on the heater harness. (Refer to Subsection 4.1.26, "Harness routing H.")
- Fit the front tabs of the low-voltage power supply PCB in openings "f."
- Fit the front tab of the insulator sheet in opening "g."

- To prevent the blue and brown lead wires of the AC power cord from getting damaged by the edge of the power inlet support or the end of screw "c," be sure to observe the following routing instructions:

For the power inlet support having no opening

- 1) Route the grounding wire between the boss and the power supply shield as shown below.
- 2) Push down the ferrite cores of the AC lead wires and grounding wire.
- 3) Secure the grounding terminal to the power inlet support with screw "c" at an angle shown below.

Push down these ferrite cores.

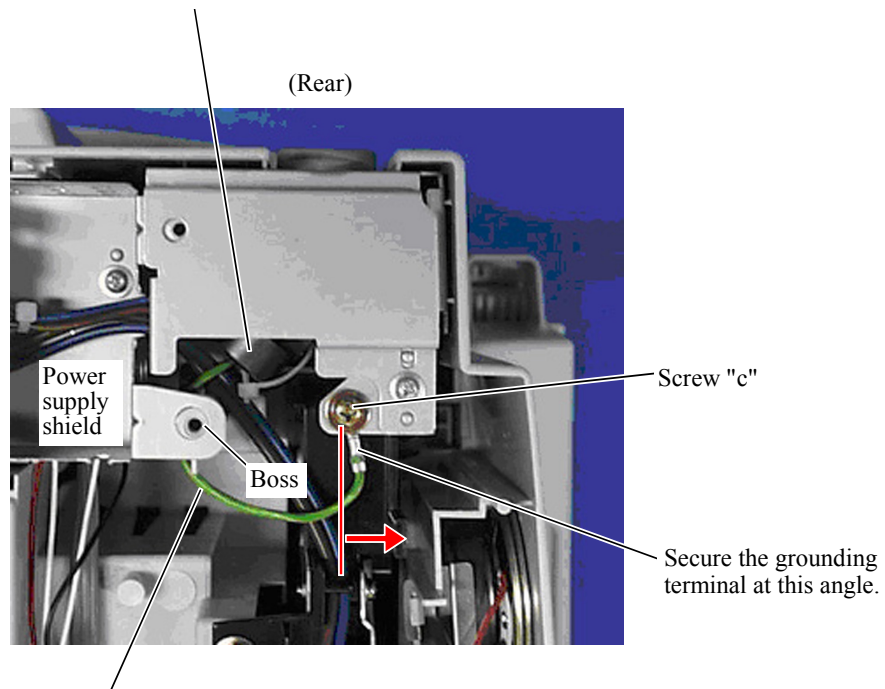

For the new type of the power inlet support having an opening

- 1) Route the AC lead wires (blue and brown) through the opening provided in the power inlet support and pull them in the direction shown below to bring the ferrite cores closer to the opening.
- 2) Fasten the AC lead wires to the power inlet support with a binder.

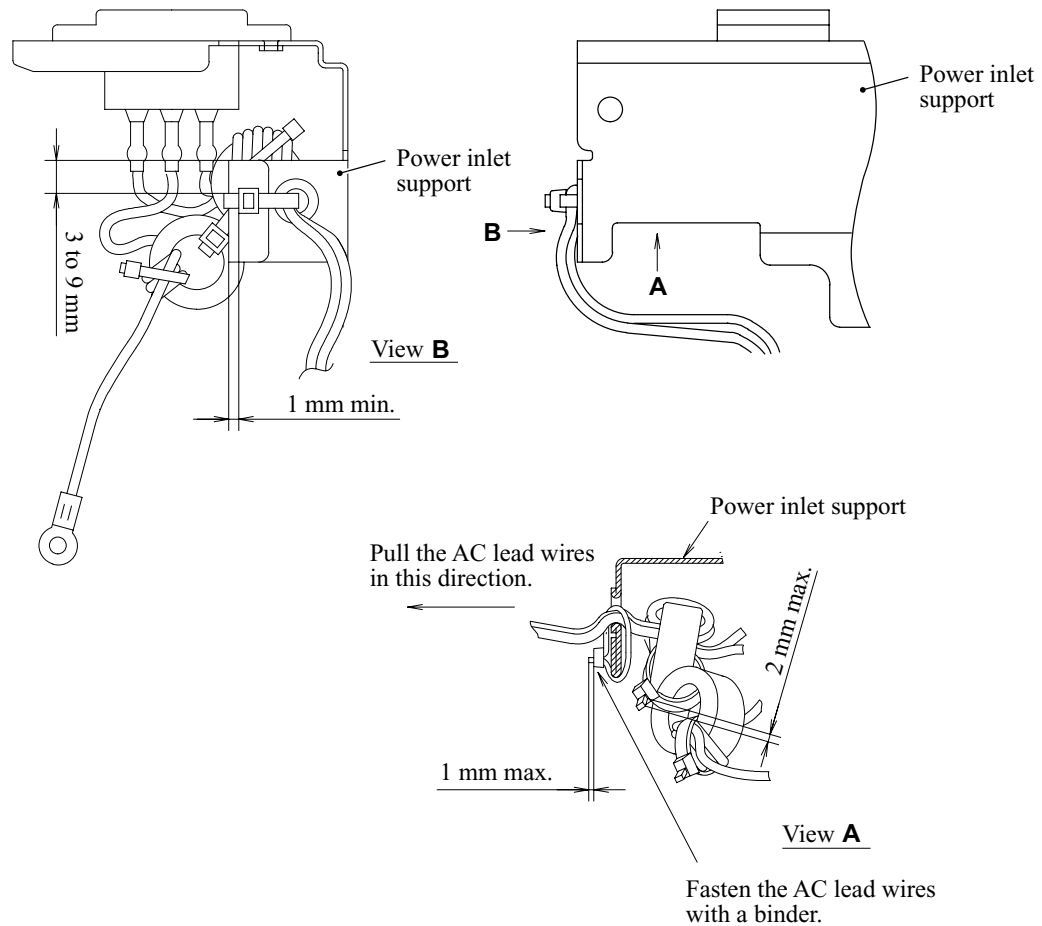

- 3) Secure the grounding wire to the power inlet support with screw "c."

4.1.16 High-voltage Power Supply PCB

- (1) Remove the screw and take off the high-voltage insulator sheet.
- (2) Slightly lift up the high-voltage power supply PCB and disconnect the high-voltage power flat cable and EL (eraser lamp) harness.

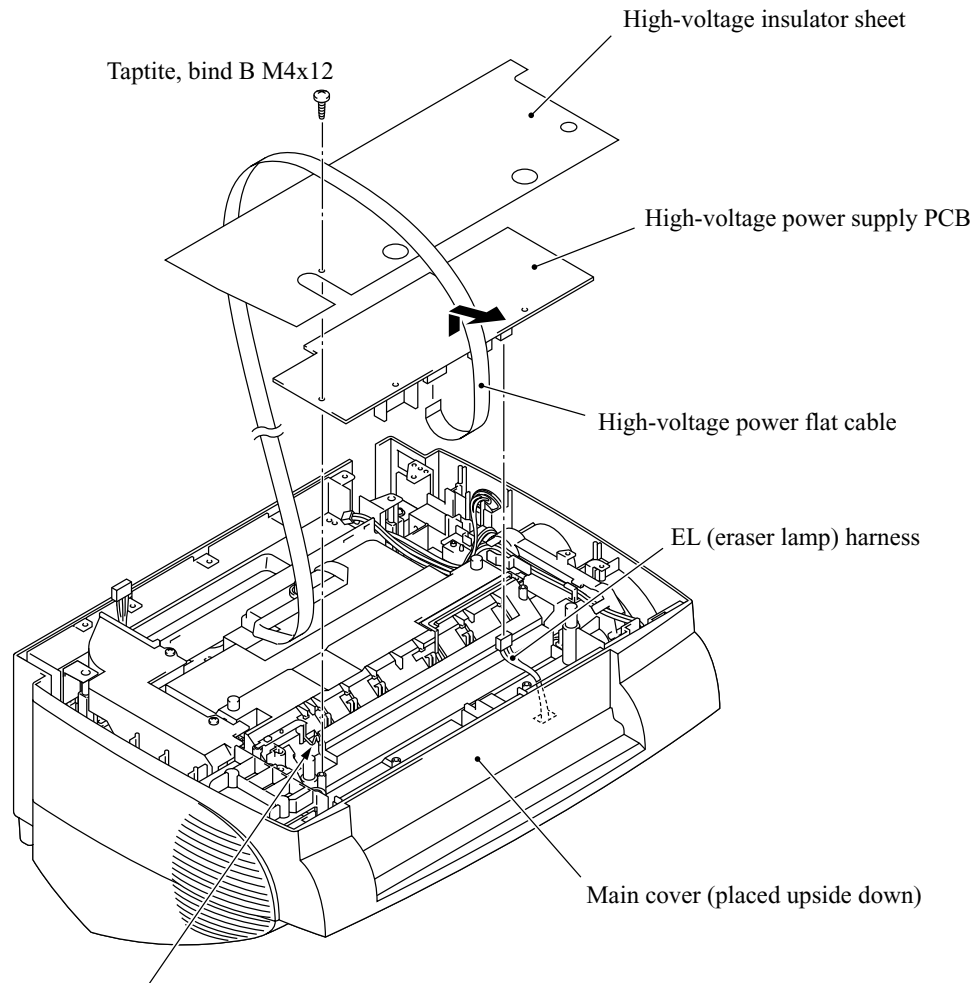

Take care not to bend this high-voltage plate.

■ Reassembling Notes

- Fold the high-voltage power flat cable and route it as illustrated above.
- Before reinstalling the high-voltage power supply PCB, check the high-voltage contacts for any toner particles, paper dust or dirt, and clean them out.
- Take care not to bend the high-voltage plate.

4.1.17 Cover/Registration Sensor PCB, Duct, and Fan

- (1) Take off the duct by removing the two screws.
- (2) Unlatch the cover/registration sensor PCB and lift it up and out of the main cover.
- (3) Disconnect the fan harness from the PCB.
- (4) Take off the fan support by removing the screw.
- (5) Lift up the fan.

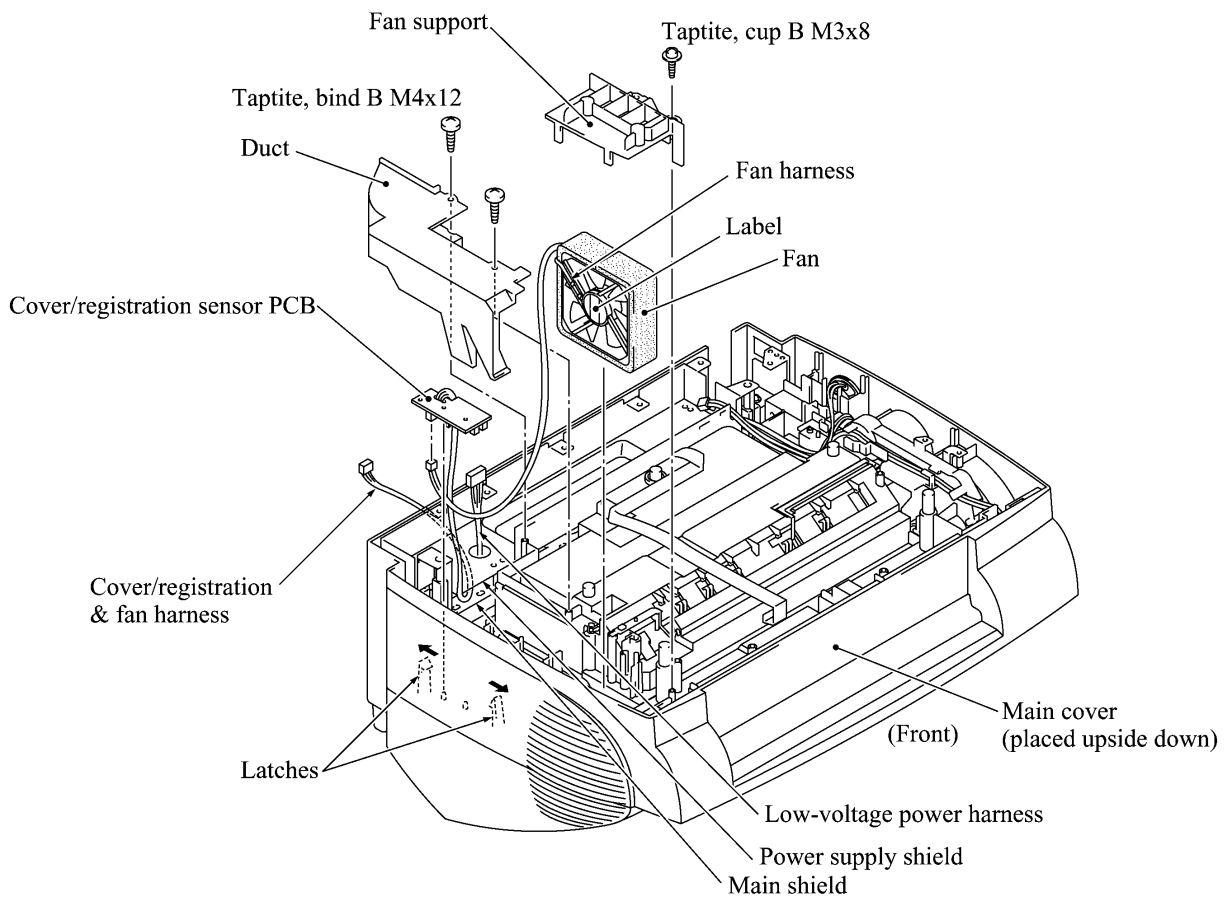

■ Reassembling Notes

- Route the fan harness on the fan as illustrated above.
- Put the fan back into place with the label side facing outwards and with its harness directed as shown above.

4.1.18 Top Cover Sensor Actuator

- (1) Pull up the top cover sensor actuator.

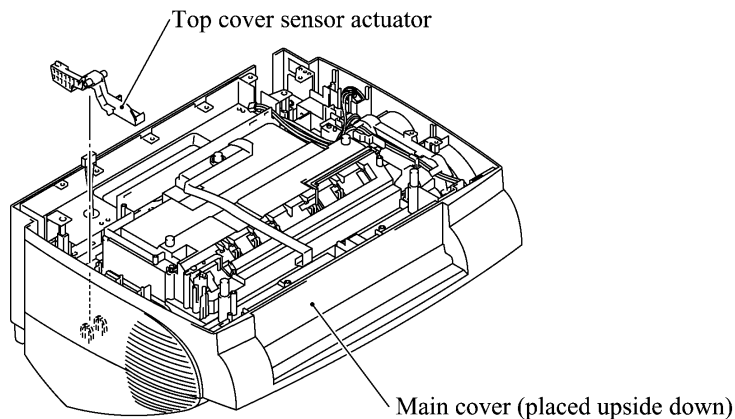

4.1.19 Power Supply Shield

- (1) Remove the two screws and lift up the power supply shield.

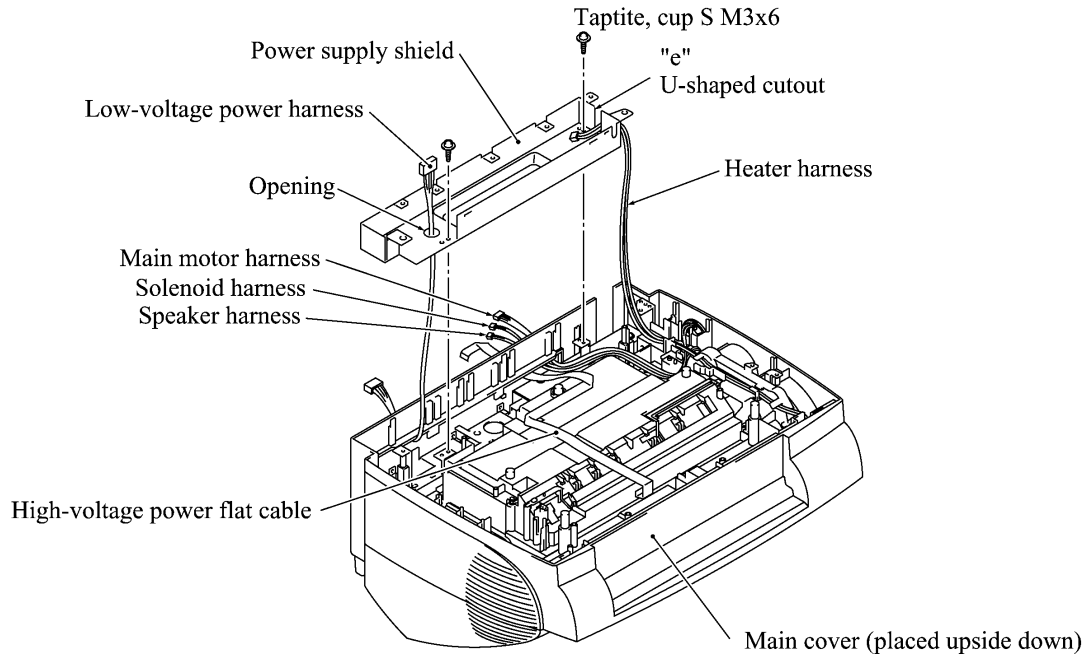

■ Reassembling Notes

- When reinstalling the power supply shield, route the low-voltage power harness through the opening and route the heater harness through U-shaped cutout "e" as shown above.

4.1.20 Speaker

- (1) Pull the speaker spring inwards and pull up the speaker together with the spring.

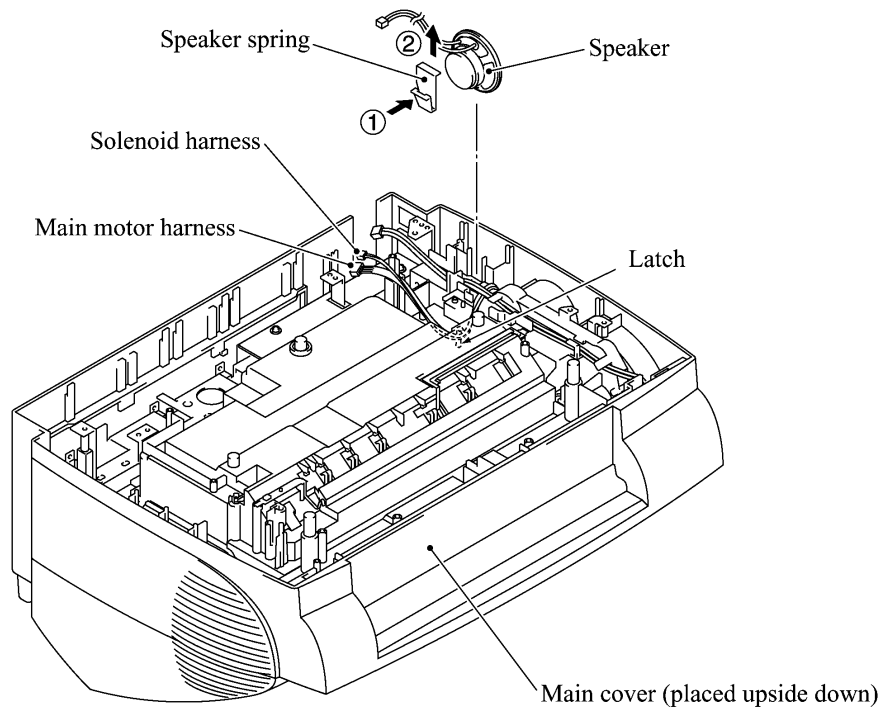

■ Reassembling Notes

- Put the speaker into place with its harness facing up.
- Route the speaker harness through the latch together with the solenoid harness and main motor harness as shown above.

4.1.21 Gear Drive Unit

- (1) Make sure that the heat-fixing unit is removed.
- (2) Take out the heater harness from the cable guides provided on the top of the gear drive unit.
- (3) Remove the four screws and lift up the gear drive unit.

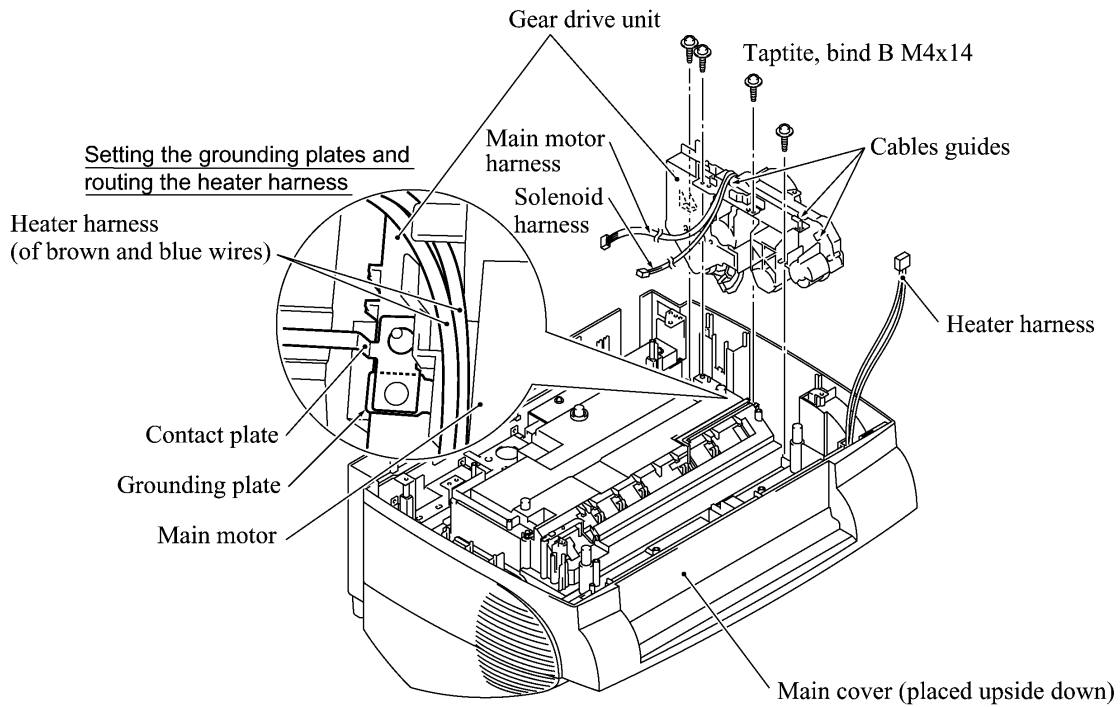

- (4) Remove the two screws and take off the main motor.

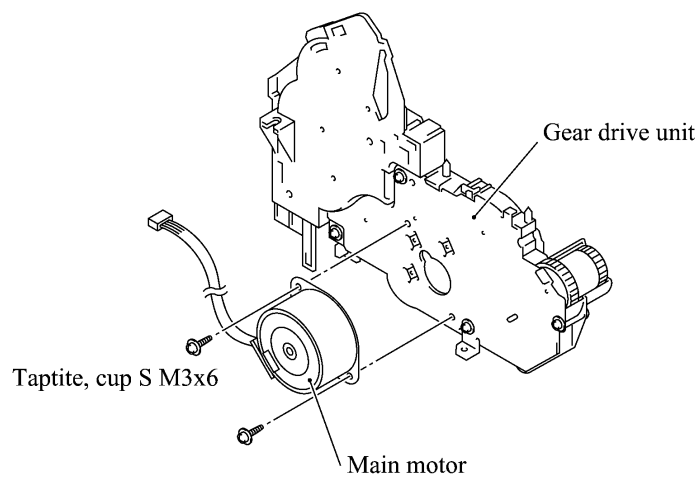

- (5) To take off the paper feed solenoid, solenoid lever, or clutch release lever, remove the two screws.

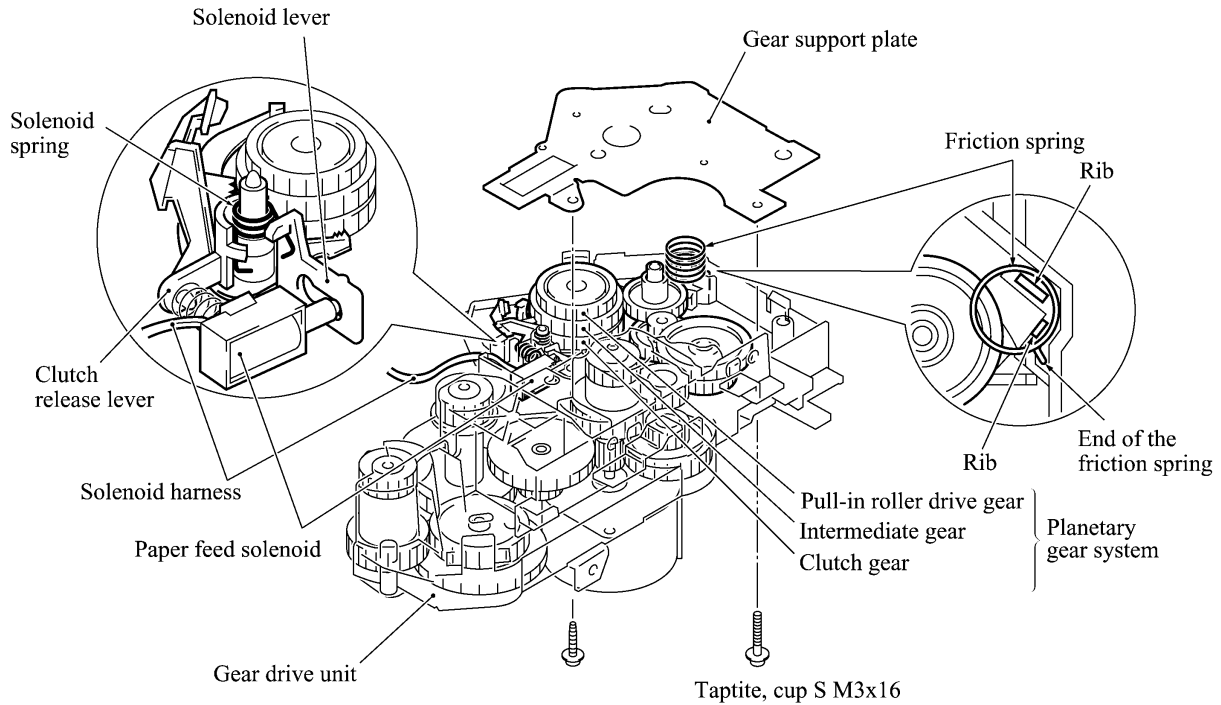

■ Reassembling Notes

- If the friction spring in the gear drive unit slips off, fit the straight end of the spring in the support hole of the gear drive unit as illustrated above.
- When putting the gear drive unit back into the main cover, route the solenoid harness and main motor harness along the outside of the gear drive unit. Be sure to sandwich the grounding plate between the contact plate and gear drive unit. See the illustration given on the previous page.
- After securing the gear drive unit, route the heater harness through the cable guides provided on the top of the gear drive unit.

4.1.22 PCB Support and NCU PCB

- (1) Remove the two screws and lift up the PCB support.

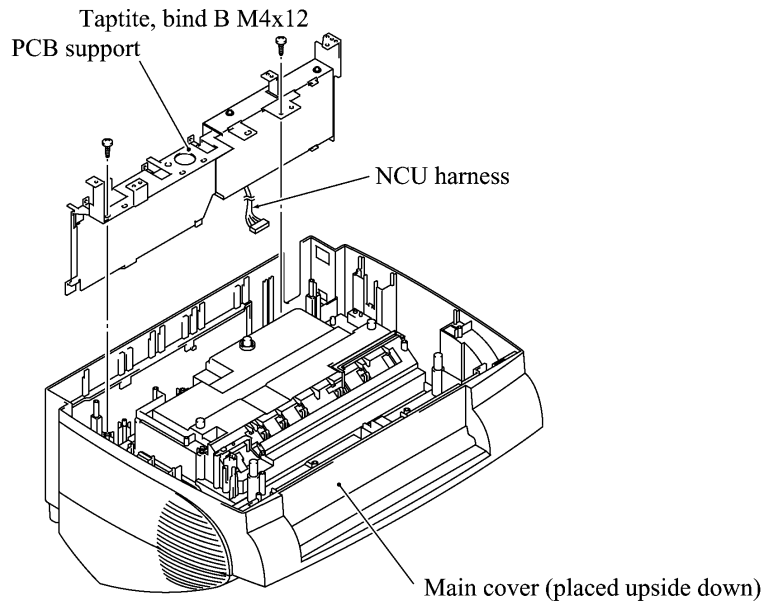

- (2) Remove the two screws and take off the NCU shield.
- (3) Remove the screw and take off the NCU PCB from the PCB support.
- (4) Disconnect the NCU harness.

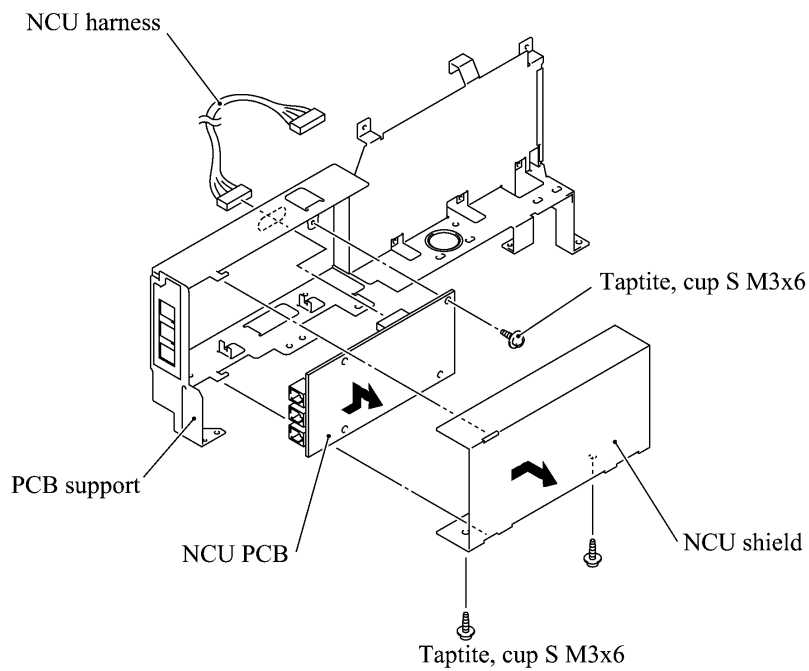

4.1.23 Side Covers R and L

- (1) To take off the side cover R: Remove the two screws, lift up the front end of the side cover R, then pull it to the front.
- (2) To take off the side cover L: Remove the two screws. While pushing the left side of the scanner grounding plate to the right (in the direction of arrow ①), lift up the front end of the side cover L and pull it to the front (arrow ②).

NOTE: If you pull up the side cover L without pushing the left side of the scanner grounding plate, the "X" section of the side cover L will catch on the scanner grounding plate.

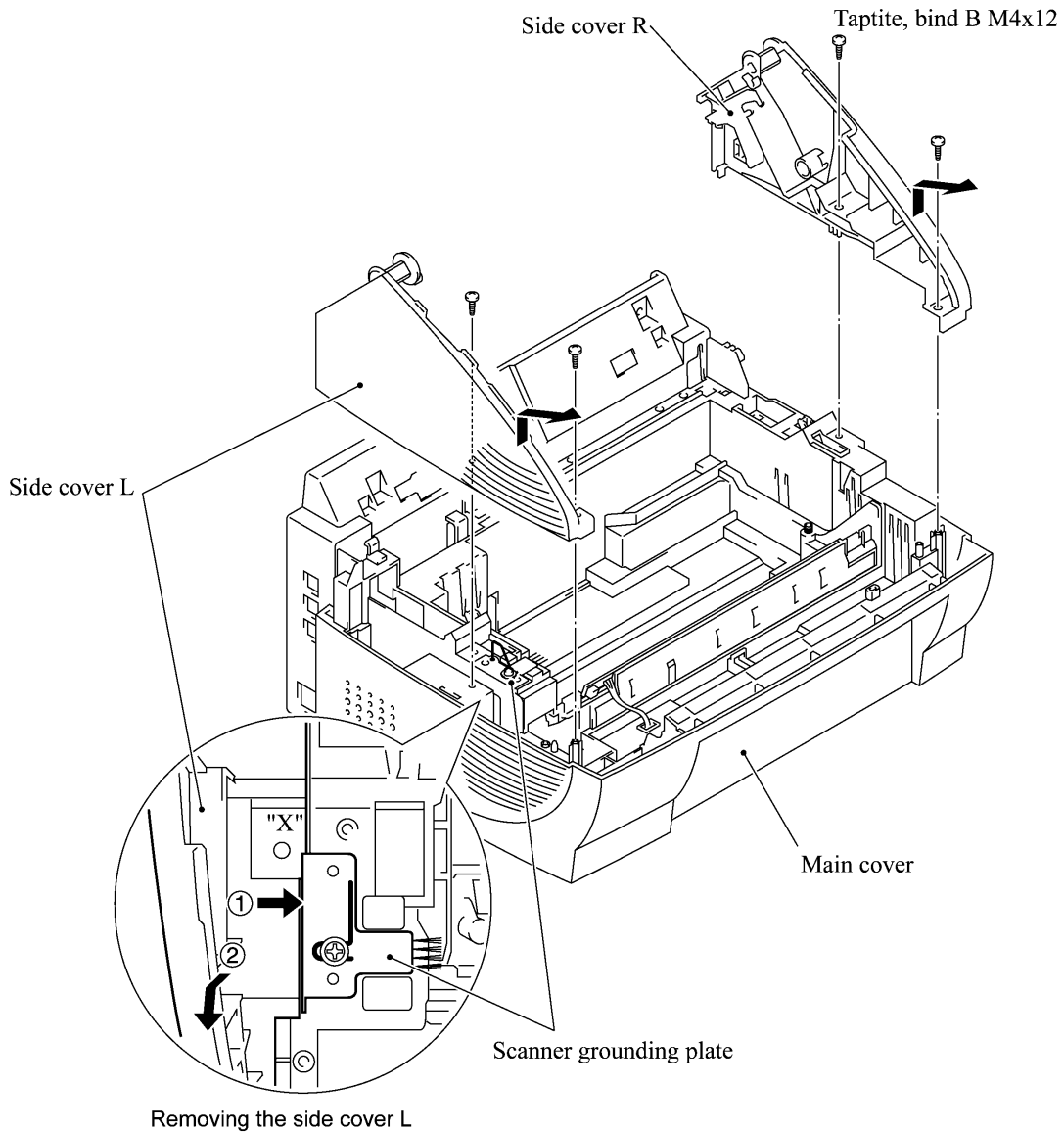

4.1.24 Scanner Grounding Plate

- (1) Make sure that the heat-fixing unit is removed.
- (2) Remove the screw from the scanner grounding plate. (If the bottom plate has not been removed, remove screw "y" also (see page 4-30) that secures both the scanner grounding plate and bottom plate.)
- (3) Slightly lift up the scanner grounding plate and unhook the spring.
- (4) You may peel off the anti-static brush from the scanner grounding plate.

NOTE: Once removed, the anti-static brush will become unusable and a new one will have to be put back in.

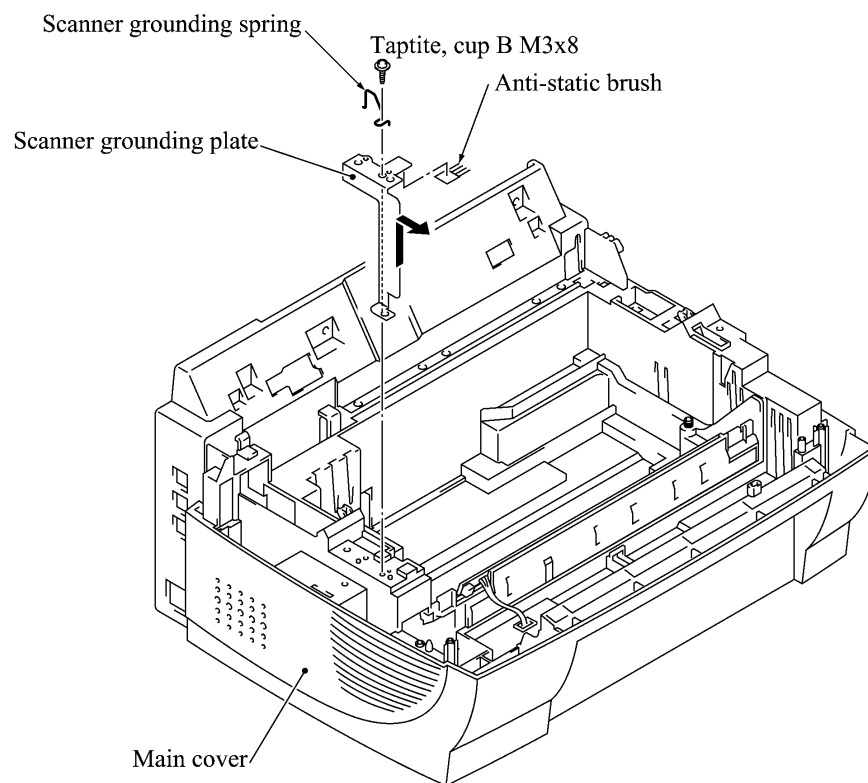

■ Reassembling Notes

- Before attaching a new anti-static brush onto the scanner grounding plate, wipe the surface of the attaching place with a cloth dampened with alcohol.
- When reinstalling the scanner grounding plate, fit it over the two bosses of the main cover.

4.1.25 EL (Eraser Lamp) Board

Only when you need to replace the EL board (which is attached with double-sided adhesive tape), remove it according to the steps below.

- (1) Make sure that the EL harness is disconnected from the high-voltage power supply PCB. (Refer to Subsection 4.1.16.)
- (2) Make sure that the heat-fixing unit is removed.
- (3) Peel off the EL board from the main cover and clear adhesive tape if remaining.

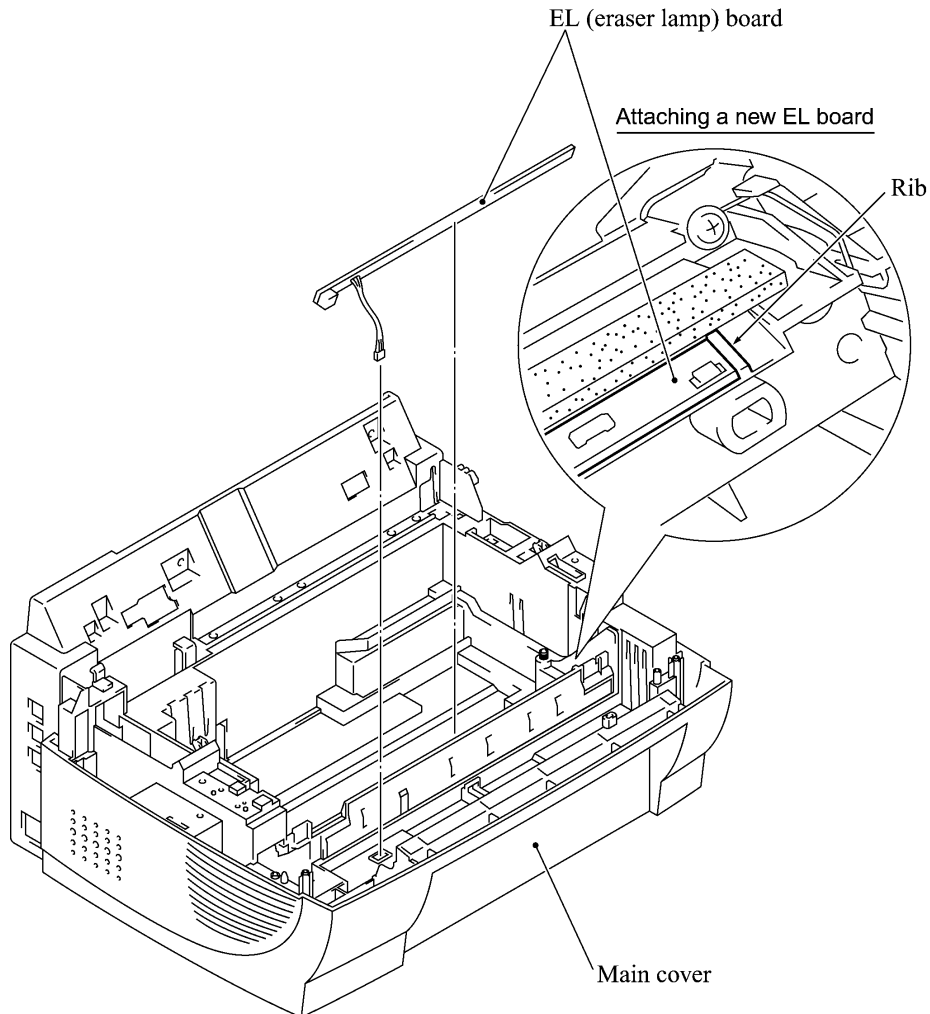

■ Reassembling Notes

- When attaching a new EL board, bring the right end into contact with the rib provided on the main cover.

4.1.26 Harness Routing

Harness routing A: Main PCB-related harnesses

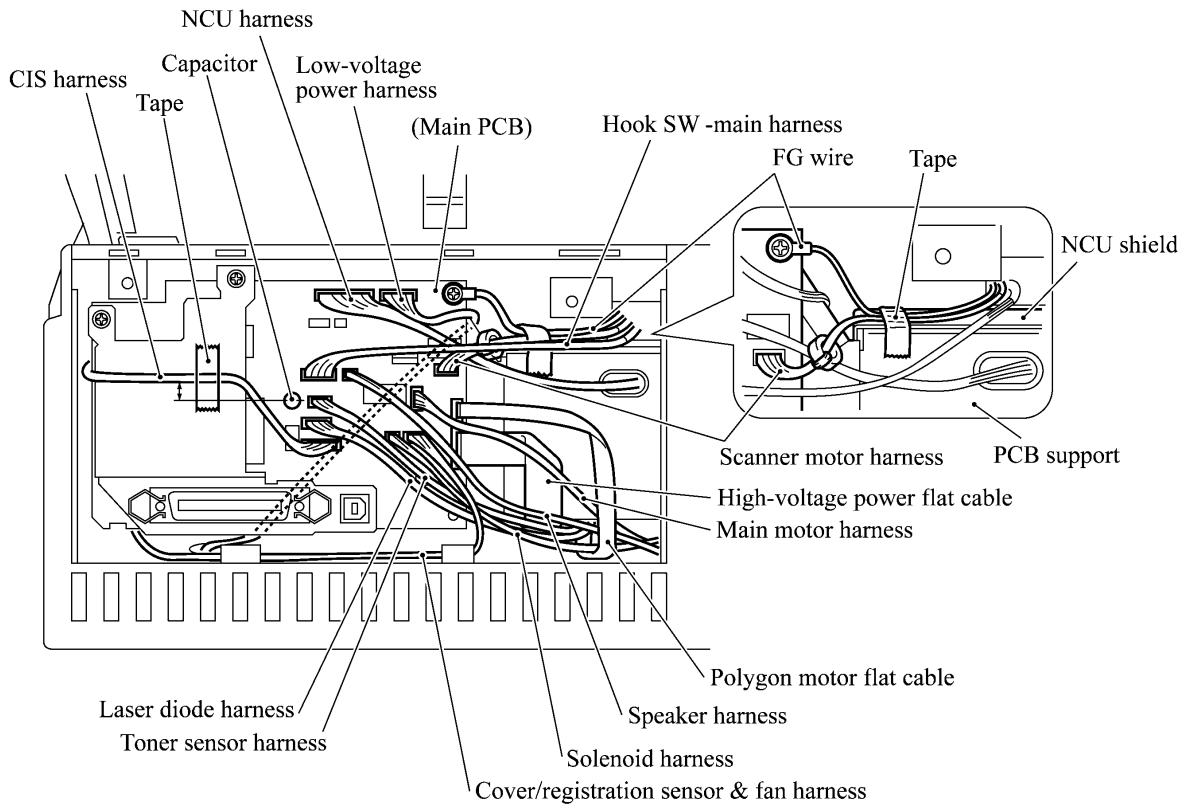

Harness routing B: Panel-hook SW harness, hook SW-main harness, and scanner motor harness on the main cover

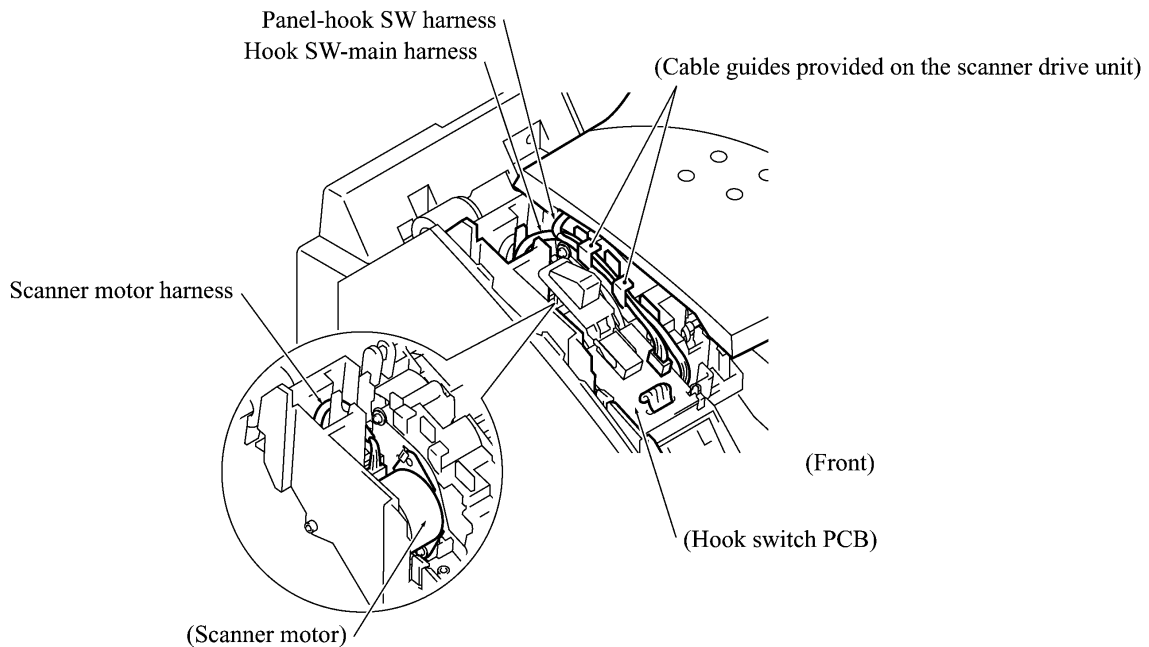

Harness routing C: Hook SW-main harness, scanner motor harness, FG wire, and CIS harness on the underside of the top cover

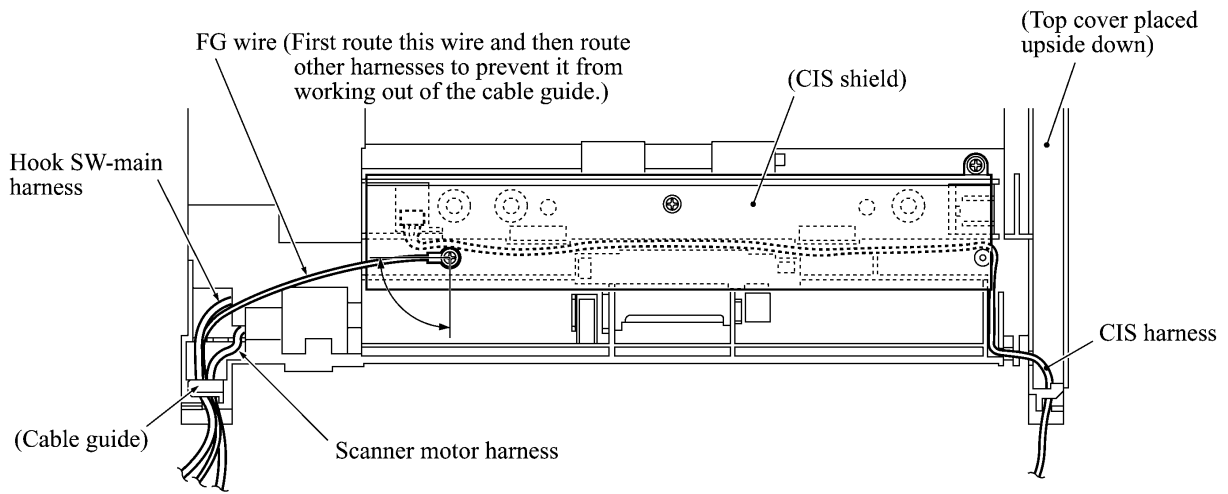

Harness routing D: Hook SW-main harness, scanner motor harness, and FG wire on the top of the main cover

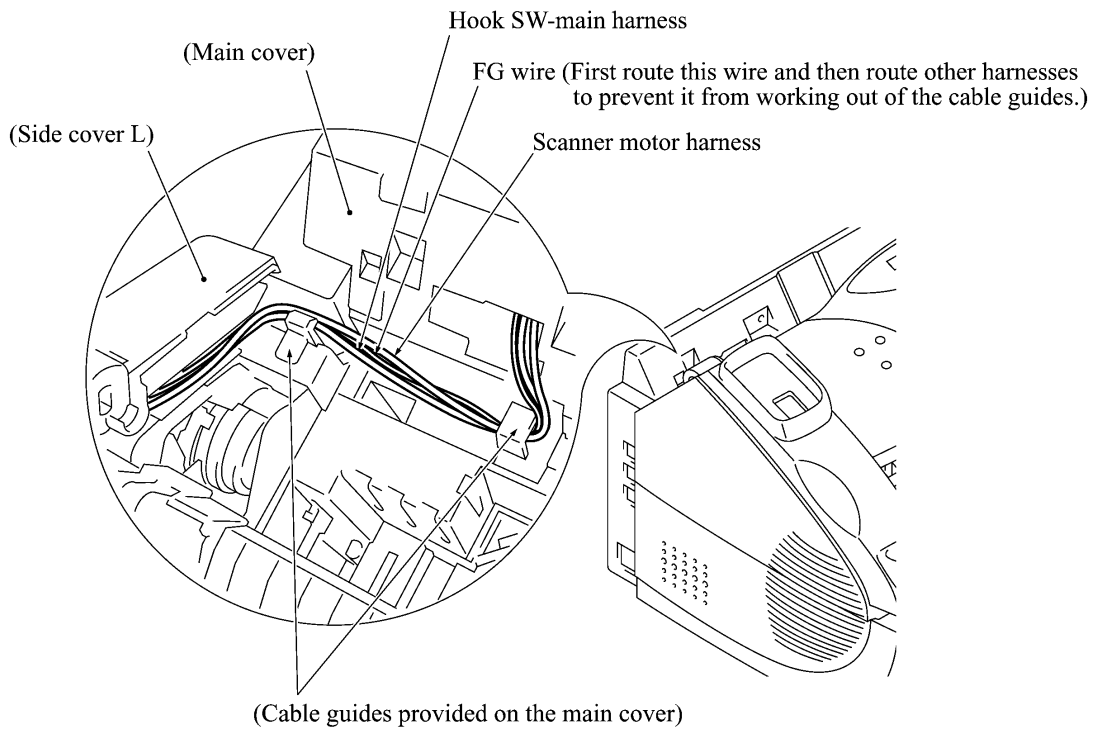

Harness routing E: CIS harness on the top of the main cover

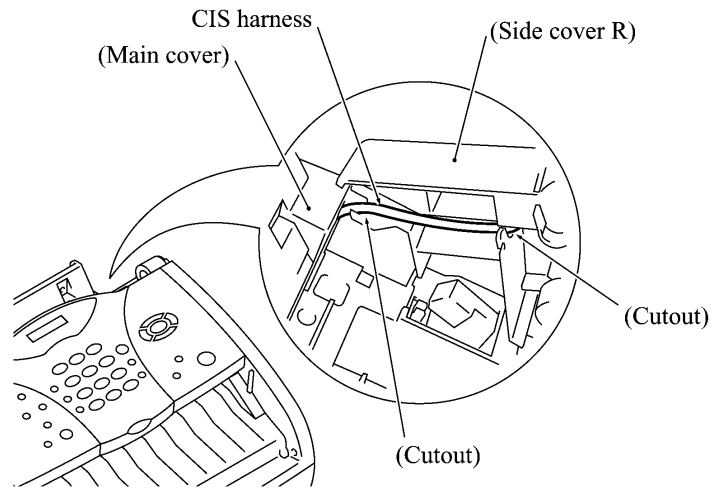

Harness routing F: Heater harness on the top of the main cover

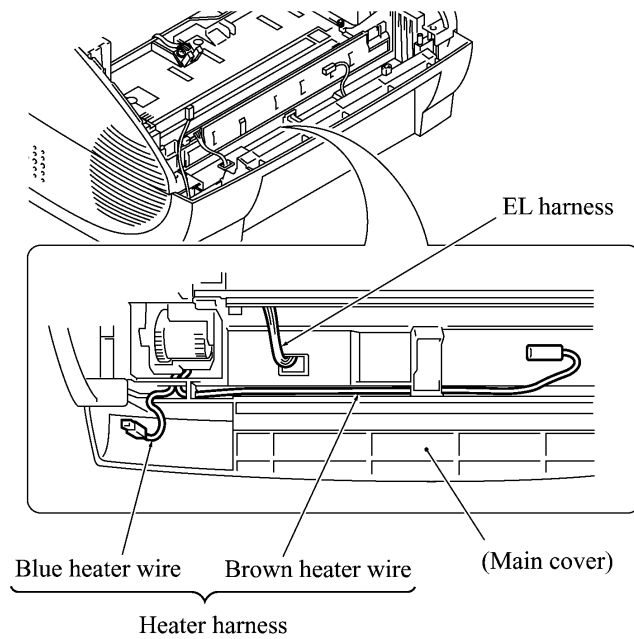

Harness routing G: Laser diode harness, polygon motor flat cable, and toner sensor harness on the laser unit

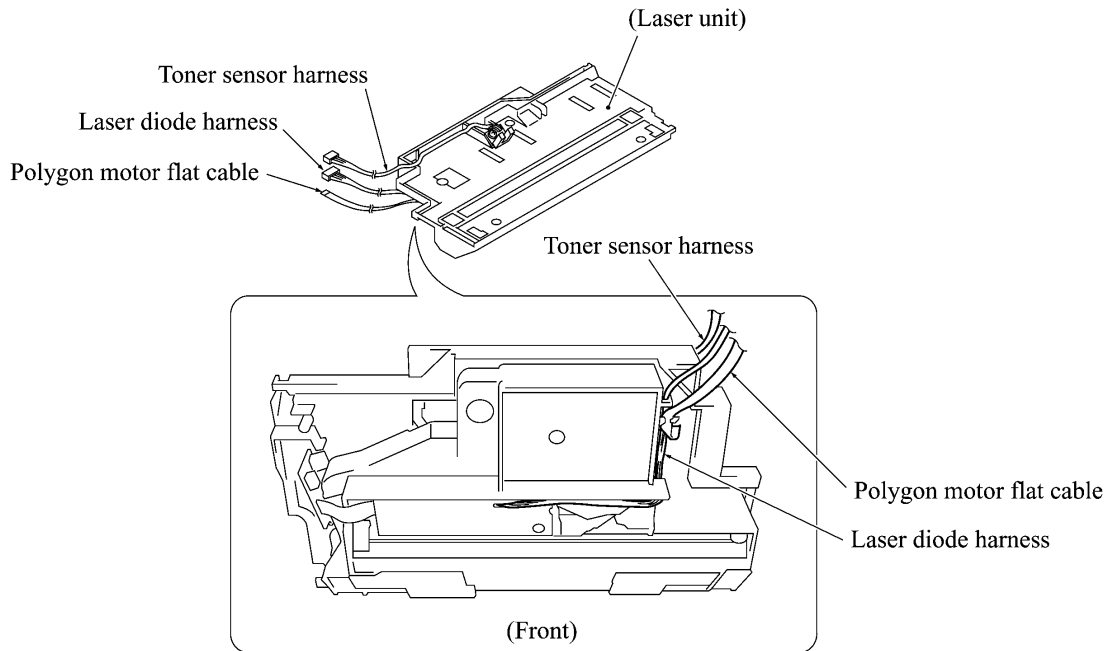

Harness routing H: Harnesses viewed from the bottom of the machine

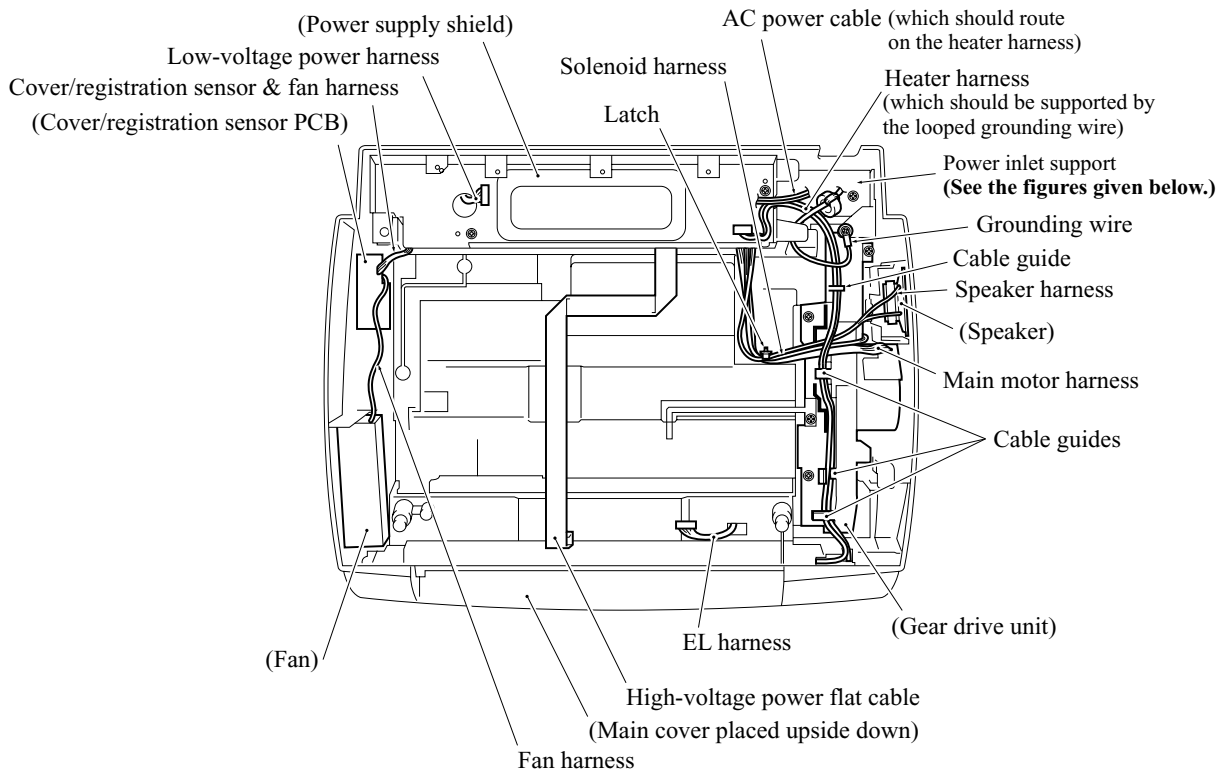

For the power inlet support having no opening

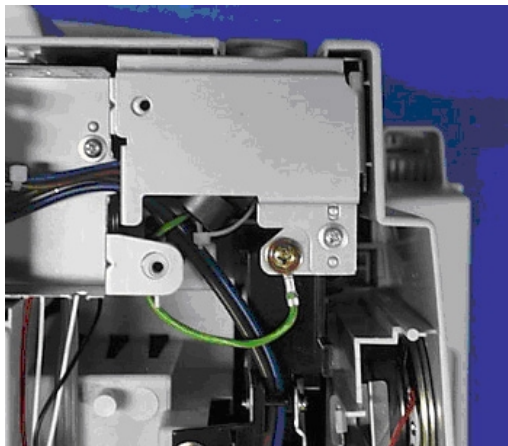

For the power inlet support having an opening

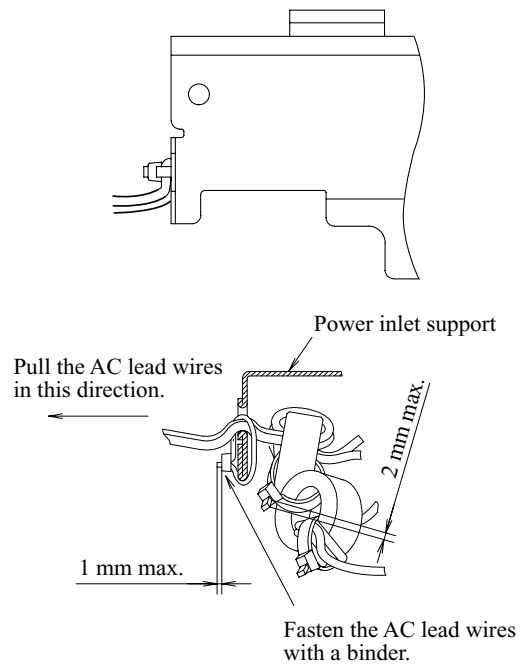

For the harness routing around the power inlet support, see page 4-31-2.

4.1.27 Cleaning of High-voltage Contacts and Grounding Contacts

If any toner particles, paper dust or dirt are on the contacts, clean them out. This will ensure that power flows correctly to enable printing.

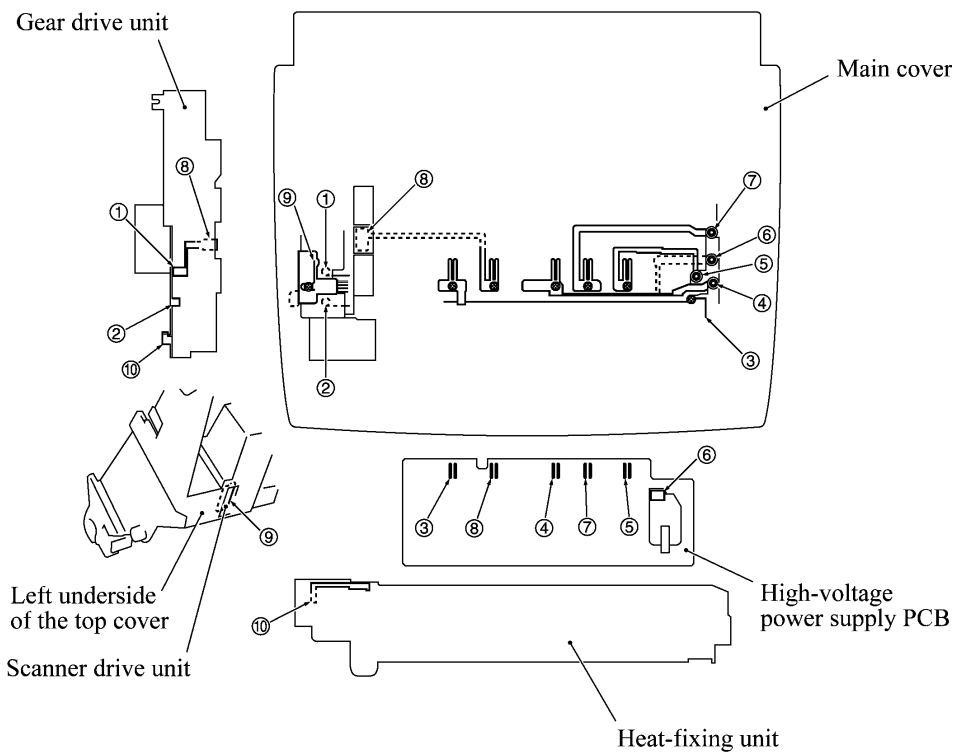
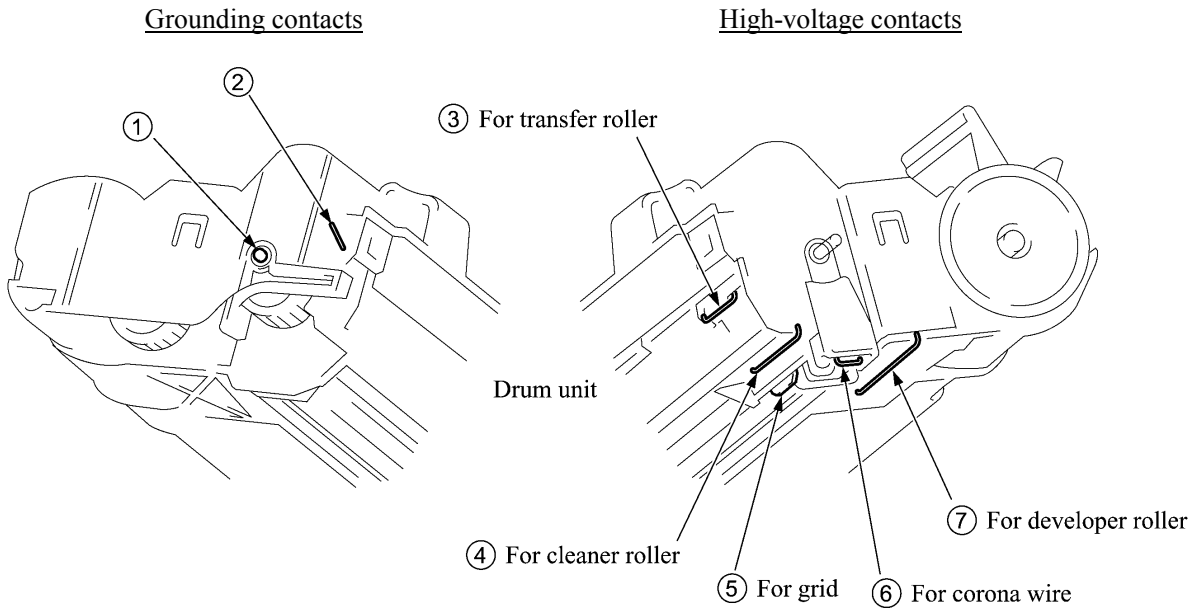

4.2 LUBRICATION

Apply the specified lubricants to the lubrication points as shown below.

Lubricant type (Manufacturer)	Lubricant amount		
	Half of rice-sized pinch of grease (2 mm dia. ball)	Rice-sized pinch of grease (3 mm dia. ball)	Two rice-sized pinches of grease (4 mm dia. ball)
Molykote EM-D110 (Dow Corning)	_____	(EMD1)	_____
Molykote grease PG-662 (Dow Corning)	_____	(PG1)	(PG2)
Conductive grease FLOIL GE676 (Kanto Kasei Ltd.)	(GE0.5)	_____	_____

[1] Separation pad

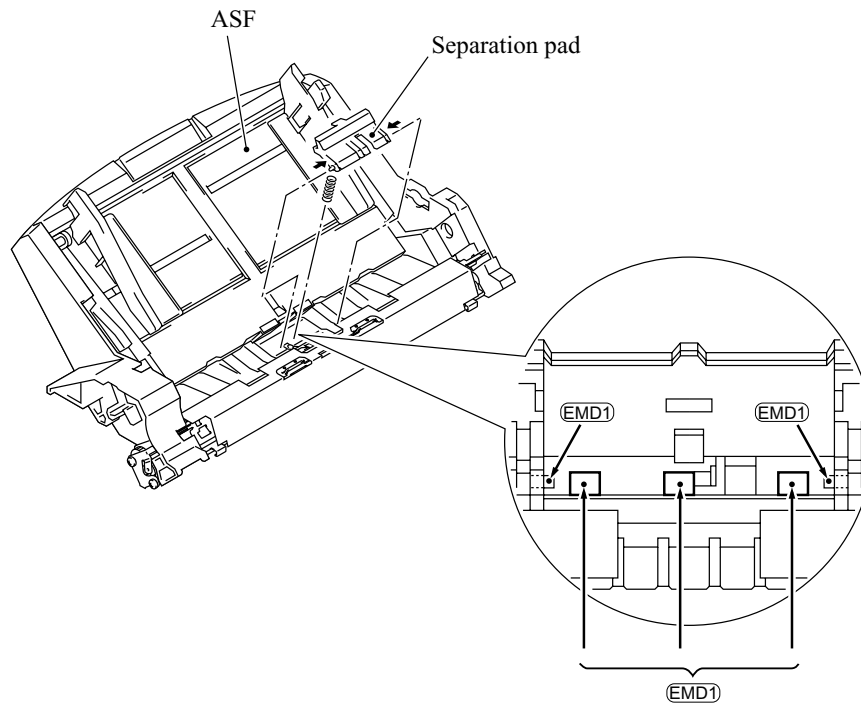

(Apply thin coat of grease to these sections with a brush where the separation pad is to be mounted.)

[2] Scanner drive unit

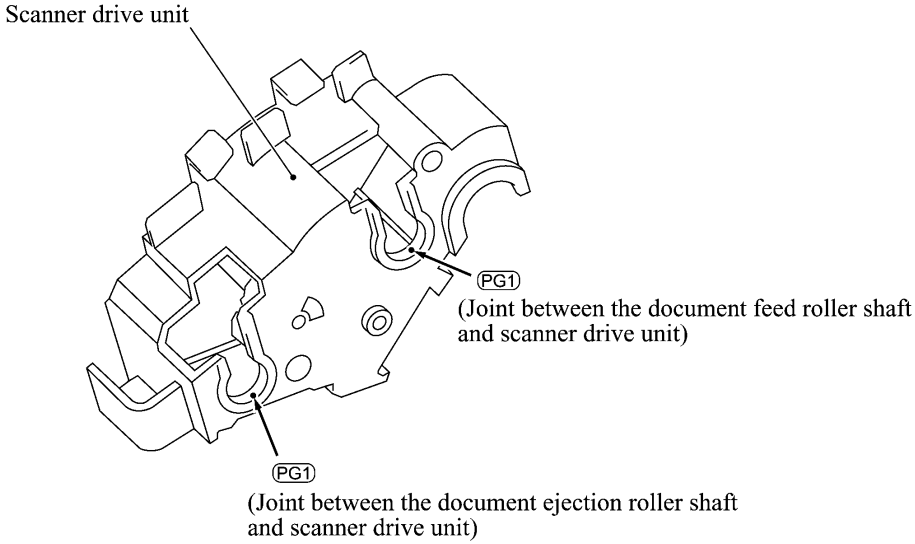

[3] Separation roller

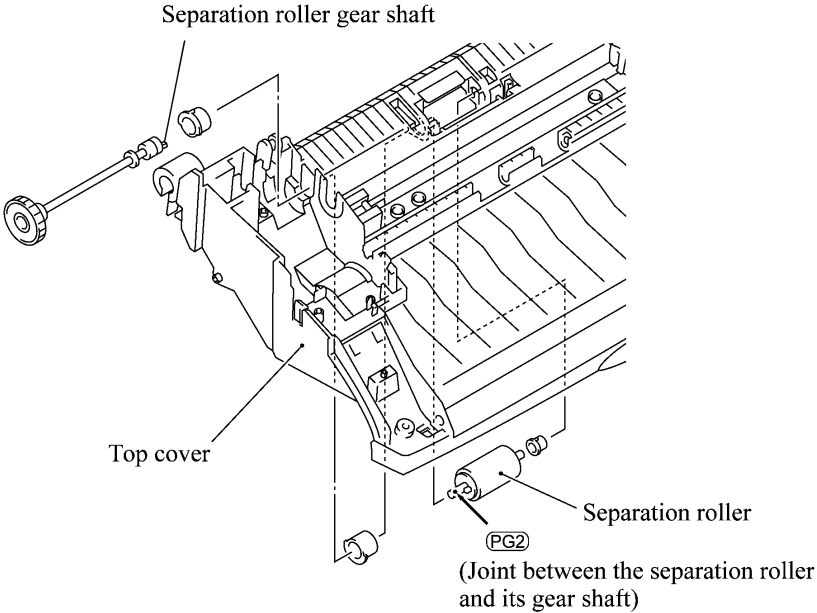

[4] Document feed roller

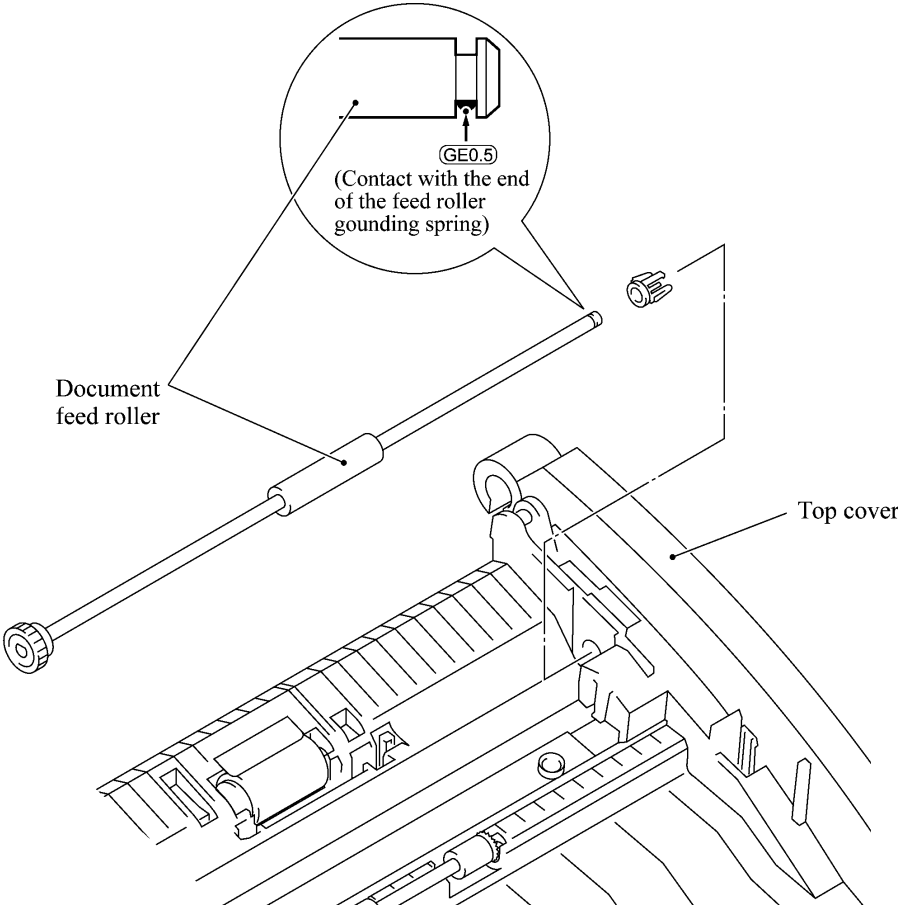

CHAPTER 5

MAINTENANCE MODE

CHAPTER 5 MAINTENANCE MODE

CONTENTS

5.1	ENTRY INTO THE MAINTENANCE MODE	5-1
5.2	LIST OF MAINTENANCE-MODE FUNCTIONS	5-2
5.3	DETAILED DESCRIPTION OF MAINTENANCE-MODE FUNCTIONS	5-4
5.3.1	EEPROM Parameter Initialization	5-4
5.3.2	Printout of Scanning Compensation Data	5-5
5.3.3	ADF Performance Test	5-7
5.3.4	Test Pattern 1	5-8
5.3.5	Firmware Switch Setting and Printout	5-9
5.3.6	Operational Check of LCD	5-12
5.3.7	Operational Check of Control Panel PCB	5-12
5.3.8	Receiver Volume Adjustment (applicable to the American version only)	5-14
5.3.9	Sensor Operational Check	5-15
5.3.10	Fine Adjustment of Scanning Start/End Position	5-16
5.3.11	CIS Scanner Area Setting	5-17
5.3.12	EEPROM Customizing	5-17
5.3.13	Display of the Equipment's Log Information	5-18
5.3.14	Equipment Error Code Indication	5-19
5.3.15	Output of Transmission Log to the Telephone Line	5-19
5.3.16	Cancellation of the Memory Security Mode (applicable to the European version only)	5-20

5.1 ENTRY INTO THE MAINTENANCE MODE

To make the equipment enter the maintenance mode, press the **Menu**, *****, **2**, **8**, **6**, and **4** keys in this order.

|← Within 2 seconds →|

The equipment beeps for approx. one second and displays " ■■ MAINTENANCE ■■■ " on the LCD, indicating that it is placed in the initial stage of the maintenance mode, a mode in which the equipment is ready to accept entry from the keys.

To select one of the maintenance-mode functions listed in Section 5.2, enter the corresponding 2-digit function code with the numerical keys on the control panel. (The details of each maintenance-mode function are described in Section 5.3.)

- NOTES:**
- Pressing the **9** key twice in the initial stage of the maintenance mode makes the equipment exit from the maintenance mode, restoring it to the standby state.
 - Pressing the **Stop** key after entering only one digit restores the equipment to the initial stage of the maintenance mode.
 - If an invalid function code is entered, the equipment resumes the initial stage of the maintenance mode.

5.2 LIST OF MAINTENANCE-MODE FUNCTIONS

Maintenance-mode Functions

Function Code	Function	Reference Subsection (Page)
01	EEPROM Parameter Initialization	5.3.1 (5-4)
02	_____	_____
03	_____	_____
04	_____	_____
05	Printout of Scanning Compensation Data	5.3.2 (5-5)
06	_____	_____
07	_____	_____
08	ADF* Performance Test	5.3.3 (5-7)
09	Test Pattern 1	5.3.4 (5-8)
10	Firmware Switch Setting	5.3.5 (5-9)
11	Printout of Firmware Switch Data	5.3.5 (5-11)
12	Operational Check of LCD	5.3.6 (5-12)
13	Operational Check of Control Panel PCB (Check of Keys and Buttons)	5.3.7 (5-12)
14	_____	_____
15	_____	_____
16	Receiver Volume Adjustment (applicable to the American version only)	5.3.8 (5-14)
32	Sensor Operational Check	5.3.9 (5-15)
54	Fine Adjustment of Scanning Start/End Position	5.3.10 (5-16)
55	CIS Scanner Area Setting	5.3.11 (5-17)
74	EEPROM Customizing	5.3.12 (5-17)
80	Display of the Equipment's Log Information	5.3.13 (5-18)
82	Equipment Error Code Indication	5.3.14 (5-19)
87	Output of Transmission Log to the Telephone Line	5.3.15 (5-19)
91	EEPROM Parameter Initialization (except the telephone number storage area)	5.3.1 (5-4)
99	Exit from the Maintenance Mode	---- (5-1)

* ADF: Automatic document feeder

----- **IMPORTANT** -----

Basically, the maintenance-mode functions listed on the previous page should be accessed by service personnel only. However, you may allow end users to access some of these under the guidance of service personnel (e.g., by telephone).

The user-accessible functions (codes 10, 11, 12, 54, 80, 82, 87 and 91) are shaded in the table given on the previous page. Function code 10 accesses the firmware switches, each of which has eight selectors. You should not allow end users to access all of those selectors, but you may allow them to access user-accessible selectors which are shaded in the firmware switch tables in Appendix 2.

The service personnel should instruct end users to follow the procedure given below.

- (1) Press the **Menu** and **Receive Mode** keys in this order.

The LCD clears the current display.

NOTE: The **Receive Mode** key is inoperable during standby for redialing and timer.

- (2) Press the **0** key.
- (3) Enter the desired function code (10, 11, 12, 54, 80, 82, 87, or 91) with the numerical keys.
For function code 10, access the desired firmware switch according to the operating procedure described in Appendix 2.
- (4) To make the equipment return to the standby state, press the **Stop** key.

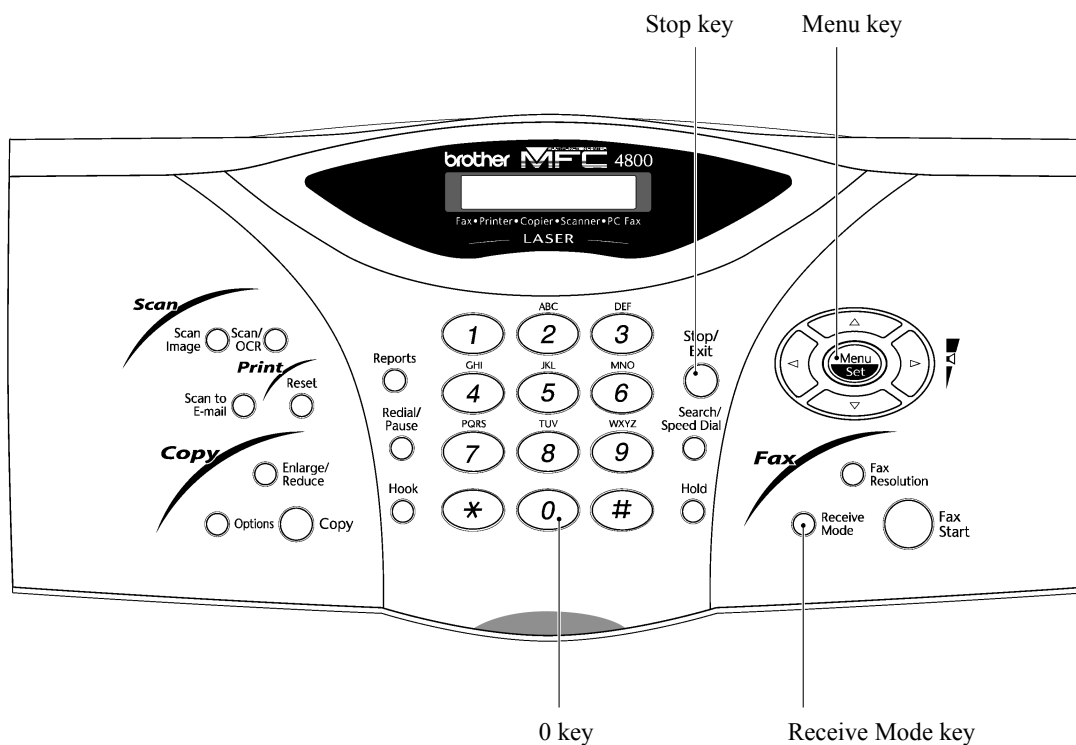

5.3 DETAILED DESCRIPTION OF MAINTENANCE-MODE FUNCTIONS

5.3.1 EEPROM Parameter Initialization

■ Function

The equipment initializes the parameters, user switches, and firmware switches registered in the EEPROM, to the initial values. Entering the function code 01 initializes all of the EEPROM areas, but entering 91 does not initialize some areas, as listed below.

Function code	01	91
Data item		
Maintenance-mode functions	All of these will be initialized	These will be initialized
User switches		
Firmware switches		
Remote activation code		
Activity report	All of these will be initialized	These will <u>not</u> be initialized
Station ID data		
Outside line number		
Telephone function registration		
One-touch dialing		
Speed dialing		
Group dialing		
Received FAX messages temporarily stored in the flash memory (Not applicable to the American version)	These will <u>not</u> be initialized.	
EEPROM customizing code (4-digit)	(Note that the first digit of the 4-digit customizing code will be initialized to "0." If the code is <u>1</u> 001, for example, it will be initialized to <u>0</u> 001.)	

NOTE: If you replace the main PCB with one used for other facsimile equipment, carry out this procedure and then customize the EEPROM (maintenance-mode function code 74 in Subsection 5.3.12).

■ Operating Procedure

- (1) Press the **0** and **1** keys (or the **9** and **1** keys according to your need) in this order in the initial stage of the maintenance mode.

The "PARAMETER INIT" will appear on the LCD.

- (2) Upon completion of parameter initialization, the equipment returns to the initial stage of the maintenance mode.

5.3.2 Printout of Scanning Compensation Data

■ Function

The equipment prints out the white and black level data for scanning compensation.

■ Operating Procedure

Do not start this function merely after powering on the equipment but start it after carrying out a sequence of scanning operation. Unless the equipment has carried out any scanning operation, this function cannot print out correct scanning compensation data. This is because at the start of scanning operation, the equipment initializes white and black level data and takes in the scanning compensation reference data.

- (1) Press the **0** and **5** keys in this order in the initial stage of the maintenance mode.

The "WHITE LEVEL 1" will appear on the LCD.

- (2) The equipment prints out the scanning compensation data list containing the following:

- a) LED light intensity value (1 byte)
- b) A/D-high value (1 byte)
- c) Compensation data for background color (1 byte)
- d) 2-value quantization black level data (1664 bytes)
- e) 2-value quantization white level data (1664 bytes)

- (3) Upon completion of recording of the compensation data list, the equipment returns to the initial stage of the maintenance mode.

NOTE: If any data is abnormal, its code will be printed in inline style, as shown on the next page.

1999-01-12-05:54

- a) 4004abde : 82
- b) 4004abd8 : a3
- c) 4004abel : 00

501c1000	:	3d 34 34 31 38 2e 38 37 31 35 32 34 2f 37 34 34
501c1010	:	36 35 3b 2d 34 2a 35 36 2e 33 35 34 33 2f 32 39
501c1020	:	30 33 34 31 30 2d 33 2f 2c 2f 2d 2d 33 32 2e 35
501c1030	:	
501c1040	:	501c1400 : 4f 4f 4d 49 4b 4c 45 48 42 47 44 3d 43 47 43 48
501c1050	:	501c1410 : 49 4d 46 4d 48 49 46 4e 3e 48 4c 42 3d 46 47 4b
501c1060	:	501c1420 : 47 4f 43 45 47 48 47 4e 41 4b 45 46 48 44 4b 42
501c1070	:	501c1430 :
501c1080	:	501c1440 :
501c1090	:	501c1450 :
501c10a0	:	501c1460 :
501c10b0	:	501c1470 :
501c10c0	:	501c1480 :
501c10d0	:	501c1490 :
501c10e0	:	501c14a0 :
501c10f0	:	501c14b0 :
501c1100	:	501c14c0 :
501c1110	:	501c14d0 :
501c1120	:	501c14e0 :
501c1130	:	501c14f0 :
501c1140	:	501c1500 :
501c1150	:	501c1510 :
501c1160	:	501c1520 :
501c1170	:	501c1530 :
501c1180	:	501c1540 :
501c1190	:	501c1550 :
501c11a0	:	501c1560 :
501c11b0	:	501c1570 :
501c11c0	:	501c1580 :
501c11d0	:	501c1590 :
501c11e0	:	501c15a0 :
501c11f0	:	501c15b0 :
501c1200	:	501c15c0 :
501c1210	:	501c15d0 :
501c1220	:	501c15e0 :
501c1230	:	501c15f0 :
501c1240	:	501c1600 :
501c1250	:	501c1610 :
501c1260	:	501c1620 :
501c1270	:	501c1630 :
501c1280	:	501c1640 :
501c1290	:	501c1650 :
501c12a0	:	501c1660 :
501c12b0	:	501c1670 :
501c12c0	:	
501c12d0	:	
501c12e0	:	
501c12f0	:	
501c1300	:	
501c1310	:	
501c1320	:	
501c1330	:	
501c1340	:	
501c1350	:	
501c1360	:	
501c1370	:	
501c1380	:	
501c1390	:	
501c13a0	:	
501c13b0	:	
501c13c0	:	
501c13d0	:	
501c13e0	:	
501c13f0	:	
	:	501c2800 : 7f 78 7a 78 7b 71 7c 7c 75 7b 7b 7b 73 7b 7a 7c
	:	501c2810 : 7c 7e 88 79 7e 73 7f 81 79 81 86 85 81 7e 80 89
	:	501c2820 : 81 86 8b 89 88 84 89 86 82 87 88 89 8d 8a 85 8b
	:	501c2830 :
	:	501c2840 :
	:	501c2850 :
	:	501c2c00 : a5 a9 a8 a3 a4 a3 9b a1 9c a5 a3 99 9b a1 9b a2
	:	501c2c10 : a8 b0 a9 ad a6 a7 a5 ae 9d ad b1 a4 9b a4 a6 ab
	:	501c2c20 : a7 b3 a8 a8 a9 a8 a6 af a2 b1 ae ab aa a7 ad a6
	:	501c2c30 : a9 aa ad a5 ac a6 a8 a7 aa a6 a8 a7 a4 a3 a2 a7
	:	501c2c40 : a1 ab ae a0 a9 a5 a6 a3 a7 a6 a2 ae a0 9d a0 a0
	:	501c2c50 : a0 a2 a7 a8 a3 a7 9f a0 9f a0 a9 97 99 9c 94 9c
	:	501c2c60 : a4 b2 a7 a2 a5 a2 a0 a0 a5 a3 aa a3 a8 a4 a5 a9
	:	501c2c70 : a8 ae a8 a8 9d a1 9d 9e 9c a5 a6 9f 98 9d a2 a1
	:	501c2c80 : a0 a8 a3 a2 9d a2 96 9f a0 a1 a3 a1 9e a2 a0 9b
	:	501c2c90 : a4 a1 a6 9e a1 9b 9f 9c 9d a7 a7 9d 9d 9d aa
	:	501c2ca0 : a4 ab a9 aa 9e a4 9d a1 a0 a4 9f 9f a1 9b 9d 8f
	:	501c2cb0 : 9e 9d a4 93 9a 95 90 97 96 94 97 8d 8d 91 8d
	:	501c2cc0 : a0 96 98 9b 93 94 9a 95 99 9e a2 9c 97 9c 9b 99
	:	501c2cd0 : a1 a0 9d 9e 97 9b 9a 98 9b a0 a7 9d 9e 9c a0 9d
	:	501c2ce0 : 9c 97 8b 88 84 86 87 87 81 8a 8b 8c 88 7e 8b 85
	:	501c2cf0 : 8b 7d 8c 87 82 82 81 83 83 85 8c 86 89 7e 89 88
	:	501c2d00 : 83 84 81 7e 7d 80 83 84 83 88 82 7f 80 81 81 7d
	:	501c2d10 : 7c 88 83 76 82 7a 7f 7b 77 7d 79 73 74 83 7b 78
	:	501c2d20 : 80 82 81 75 7c 79 72 73 74 60 4b 4a 4a 4b 4b
	:	501c2d30 : 4b 4a 4e 4e 4b 4b 47 45 47 41 45 45 43 43 45 4a 4b
	:	501c2d40 : 4e 4b 4b 4b 4b 4b 4b 4b 4b 4b 4b 4b 4b 4b 4b 4b
	:	501c2d50 : 4b 4b 4b 4b 4b 4b 4b 4b 4b 4b 4b 4b 4b 4b 4b 4b
	:	501c2d60 : 5b 4b 4b 4b 66 69 77 81 75 85 82 84 79 77 7d 77 7b
	:	501c2d70 : 7e 7a 82 79 74 7c 7c 7e 78 7c 7a 72 77 77 79 73
	:	501c2d80 : 7a 7b 7e 75 7b 74 76 82 76 80 78 79 77 7a 7f 7f
	:	501c2d90 : 83 82 7d 7e 77 80 7c 7d 82 85 7f 77 75 77 81 7c
	:	501c2da0 : 79 84 7d 7a 7e 83 76 79 7c 7b 7c 88 85 8f 90
	:	501c2db0 : 95 9b 96 94 8b 8c 91 8e 94 94 95 90 8a 89 8d 92
	:	501c2dc0 : 97 95 91 8d 8d 95 89 93 98 90 93 8a 87 92 93 8f
	:	501c2dd0 : 98 9b 9c 91 90 94 90 93 94 96 95 8d 8c 8b 8e 89
	:	501c2de0 : 9d 9a 9c 92 97 8f 94 9c 95 9d 99 97 9b 93 9c 9c
	:	501c2df0 : 9c 9f 95 8f 8c 8c 94 92 93 9c 9a 98 8f 8f 99 8e
	:	501c2e00 : 9a 95 98 92 91 8e 94 93 93 9e a0 9b 99 94 9e 97
	:	501c2e10 : 9b 9f 9a 95 93 86 94 97 97 98 99 96 94 91 93 9c
	:	501c2e20 : 98 99 98 93 95 90 93 92 96 9b 94 8e 99 90 92 92
	:	501c2e30 : 8c 97 8e 88 90 8b 8a 8d 87 8b 8f 8a 88 89 82 87
	:	501c2e40 : 8e 90 90 8a 89 86 8b 93 8b 95 8e 92 8e 87 8c 93
	:	501c2e50 : 93 8f 90 92 91 84 8b 8d 90 99 90 88 88 86 91 8a
	:	501c2e60 : 88 96 93 91 92 90 8c 89 92 96 8f 94 8d 8a 92 8d
	:	501c2e70 : 94 8d 93 8e 8c 92 91 94 92 99 93 93 93 91 87 94

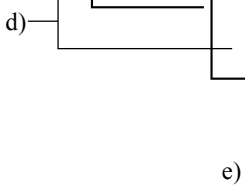

Scanning Compensation Data List

5.3.3 ADF Performance Test

■ Function

The equipment counts the documents fed by the automatic document feeder (ADF) and displays the count on the LCD for checking the ADF performance.

■ Operating Procedure

- (1) Set documents. (Allowable up to the ADF capacity.)

The "DOC. READY" will appear on the LCD.

- (2) Press the **0** and **8** keys in this order.

While counting the documents, the equipment feeds them in and out, displaying the current count on the LCD as shown below.

ADF CHECK P.01

↑ Current count (1st page in this example)

- (3) After showing the final count, the equipment beeps for one second. To return the equipment to the initial stage of the maintenance mode, press the **Stop** key.

5.3.4 Test Pattern 1

■ Function

This function, much like the copying function, prints out test pattern 1 to allow the service personnel to check for record data missing or print quality.

■ Operating Procedure

Press the **0** and **9** keys in this order in the initial stage of the maintenance mode.

The figure below shows test pattern 1.

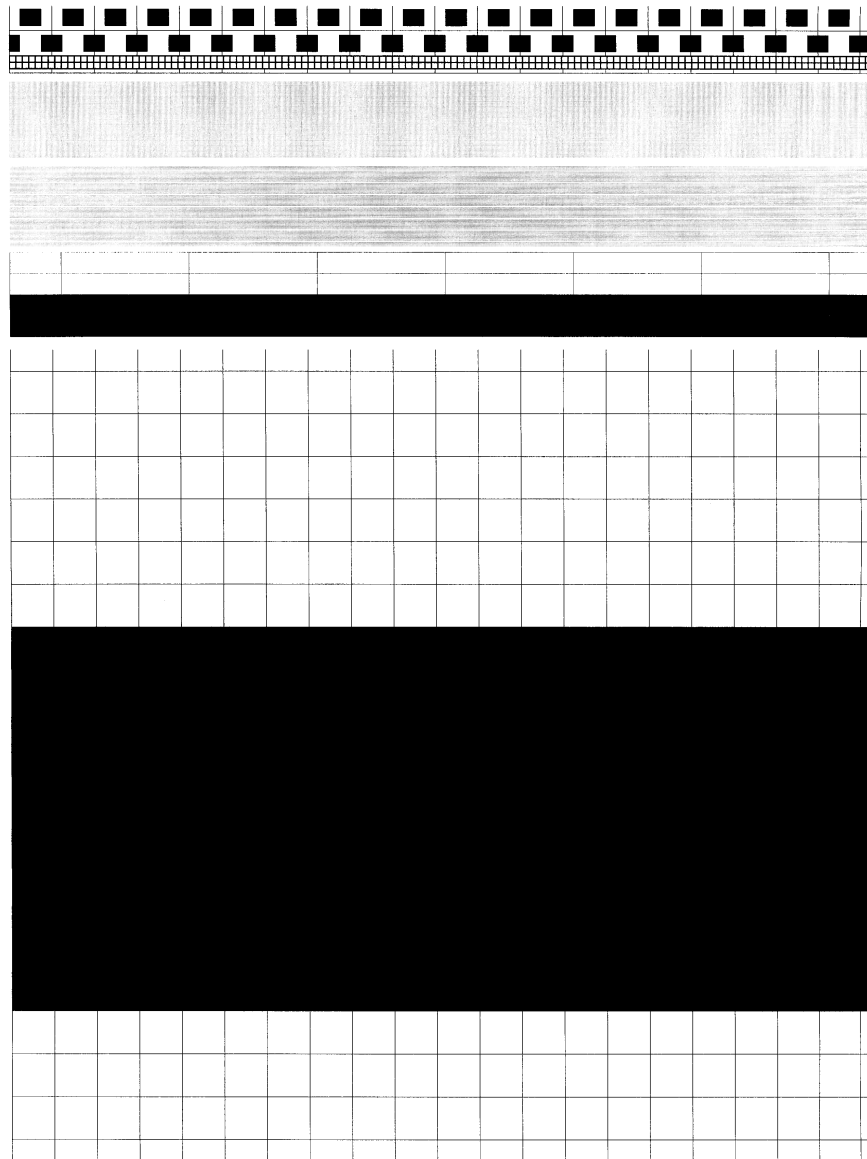

Test Pattern 1

5.3.5 Firmware Switch Setting and Printout

[A] Firmware switch setting

■ Function

The facsimile equipment incorporates the following firmware switch functions which may be activated with the procedures using the control panel keys and buttons.

The firmware switches have been set at the factory in conformity to the communications standards and codes of each country. Do not disturb them unless necessary. Some firmware switches may not be applicable in some versions. The firmware switch data list indicates "Not used." for those inapplicable switches.

Firmware Switches (WSW01 through WSW46)

WSW No.	Function
WSW01	Dial pulse setting
WSW02	Tone signal setting
WSW03	PABX mode setting
WSW04	TRANSFER facility setting
WSW05	1st dial tone and busy tone detection
WSW06	Pause key setting and 2nd dial tone detection
WSW07	Dial tone setting 1
WSW08	Dial tone setting 2
WSW09	Protocol definition 1
WSW10	Protocol definition 2
WSW11	Busy tone setting
WSW12	Signal detection condition setting
WSW13	Modem setting
WSW14	AUTO ANS facility setting
WSW15	REDIAL facility setting
WSW16	Function setting 1
WSW17	Function setting 2
WSW18	Function setting 3
WSW19	Transmission speed setting in V. 17 mode
WSW20	Overseas communications mode setting
WSW21	TAD setting 1
WSW22	ECM setting
WSW23	Communications setting
WSW24	TAD setting 2
WSW25	TAD setting 3
WSW26	Function setting 4
WSW27	Function setting 5
WSW28	Function setting 6
WSW29	Function setting 7
WSW30	Function setting 8
WSW31	Function setting 9
WSW32	Function setting 10
WSW33	Function setting 11

Firmware Switches (WSW01 through WSW46) *Continued*

WSW No.	Function
WSW34	Function setting 12
WSW35	Function setting 13
WSW36	Function setting 14
WSW37	Function setting 15
WSW38	Function setting 16 in V. 34 mode
WSW39	Transmission speed setting in V. 34 mode
WSW40	Function setting 17 in V. 34 mode
WSW41	CCD fluorescent lamp and modem attenuator in V. 34 mode
WSW42	Function setting 18
WSW43	Function setting 19
WSW44	Speeding up scanning-1
WSW45	Speeding up scanning-2
WSW46	Monitor of PC ON/OFF state

■ **Operating Procedure**

- (1) Press the **1** and **0** keys in this order in the initial stage of the maintenance mode.

The equipment displays the "WSW00" on the LCD and becomes ready to accept a firmware switch number.

- (2) Enter the desired number from the firmware switch numbers (01 through 46).

The following appears on the LCD:

Selector No. 1 Selector No. 8
 ↓ ↓
 WSWXX = 0 0 0 0 0 0 0

- (3) Use the right and left arrow keys to move the cursor to the selector position to be modified.
- (4) Enter the desired number using the **0** and **1** keys.
- (5) Press the **Set** key. This operation saves the newly entered selector values onto the EEPROM and readies the equipment for accepting a firmware switch number.
- (6) Repeat steps (2) through (5) until the modification for the desired firmware switches is completed.
- (7) Press the **Set** or **Stop** key to return the equipment to the initial stage of the maintenance mode.

NOTES:

- To cancel this operation and return the equipment to the initial stage of the maintenance mode during the above procedure, press the **Stop** key.
- If there is a pause of more than one minute after a single-digit number is entered for double-digit firmware switch numbers, the equipment will automatically return to the initial stage of the maintenance mode.

■ **Details of Firmware Switches**

The details of the firmware switches are described in Appendix 2 in which the user-accessible selectors of the firmware switches are shaded.

[B] Printout of firmware switch data

■ Function

The equipment prints out the setting items and contents specified by the firmware switches.

■ Operating Procedure

- (1) Press the **1** key twice in the initial stage of the maintenance mode.
The "PRINTING" will appear on the LCD.
- (2) The equipment prints out the configuration list as shown in the figure below.
- (3) Upon completion of printing, the equipment returns to the initial stage of the maintenance mode.

CONFIGURATION LIST

MODEL : 8X5-613
TIME : 01/12/1999 05:46
REV. : U0104110907VER.0
PCI : 5.00
SUM : 941D
SER.# : BR0100000134

```
WSW01 = 00000010
WSW02 = 11111010
WSW03 = 10000000
WSW04 = 00010111
WSW05 = 00000110
WSW06 = 00101100
WSW07 = 01001100
WSW08 = 01100100
WSW09 = 00000000
WSW10 = 00010100
WSW11 = 01011000
WSW12 = 10011011
WSW13 = 00011010
WSW14 = 01100110
WSW15 = 00001110
WSW16 = 01100010
WSW17 = 00100011
WSW18 = 10001010
WSW19 = 11100000
WSW20 = 10011111
WSW21 = 00101000
WSW22 = 00000000
WSW23 = 00001110
WSW24 = 01000010
WSW25 = 00011010
WSW26 = 00110010
WSW27 = 00100001
WSW28 = 00000000
WSW29 = 01101001
WSW30 = 10000000
WSW31 = 11100101
WSW32 = 01010000
WSW33 = 10000010
WSW34 = 00010000
WSW35 = 01000000
WSW3 = 00001000
WSW37 = 10000101
WSW38 = 00010100
WSW39 = 11110000
WSW40 = 00000000
WSW41 = 00000111
WSW42 = 11110100
WSW43 = 00000001
WSW44 = 00000010
WSW45 = 00000000
WSW46 = 00000000
```

Configuration List

5.3.6 Operational Check of LCD

■ Function

This function allows you to check whether the LCD on the control panel works normally.

■ Operating Procedure

- (1) Press the **1** and **2** keys in this order in the initial stage of the maintenance mode.

The LCD shows

- (2) Press the **Fax Start** key. Each time you press the **Fax Start** key, the LCD cycles through the displays shown at right.

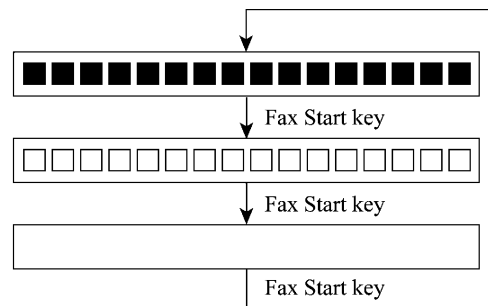

- (3) Press the **Stop** key in any process of the above display cycle. The equipment beeps for one second and returns to the initial stage of the maintenance mode.

5.3.7 Operational Check of Control Panel PCB

■ Function

This function allows you to check the control panel PCB for normal operation.

■ Operating Procedure

- (1) Press the **1** and **3** keys in this order in the initial stage of the maintenance mode.

The "00 " will appear on the LCD.

- (2) Press the keys and buttons in the order designated in the illustration shown below.

The LCD shows the corresponding number in decimal notation each time a key or button is pressed. Check that the displayed number is correct by referring to the illustration below.

If a key or button is pressed out of order, the equipment beeps and displays the "INVALID OPERATE" on the LCD. To return to the status ready to accept key & button entry for operational check, press the **Stop** key.

- (3) After the last number key or button is pressed, the equipment beeps and returns to the initial stage of the maintenance mode.

To terminate this operation, press the **Stop** key. The equipment returns to the initial stage of the maintenance mode.

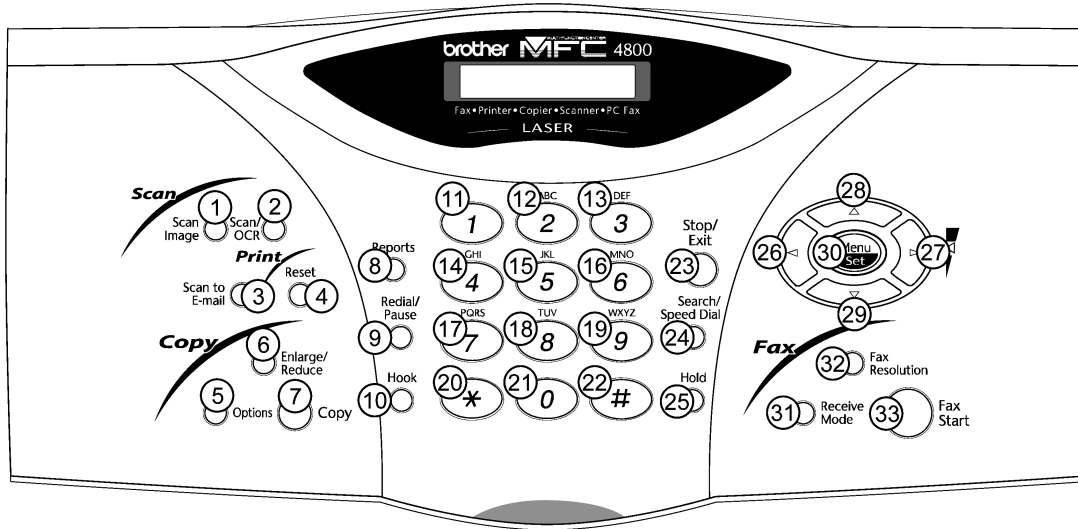

Key & Button Entry Order

5.3.8 Receiver Volume Adjustment (applicable to the American version only)

■ Function

The facsimile equipment may switch the handset receiver's volume between three levels--Low, High, and Amplify*.

(*Amplify level: Extra-high volume for users who are deaf or hard of hearing.)

The volume at Low or Amplify level is fixed and not adjustable. The volume at High level will be influenced by the characteristics of the FET on the main PCB, so it requires fine adjustment according to the procedure given below.

■ Operating Procedure

- (1) Connect the telephone line cord to the modular jack of the facsimile equipment and the telephone wall socket.
- (2) Pick up the handset and listen to the dial tone. If the receiver volume is not appropriate, proceed to the following steps:
- (3) Press the **1** and **6** keys in this order in the initial stage of the maintenance mode.

The LCD shows the current receiver volume (default: High).

Low level	L O W ■ ■ _ _ _ _ H I G H _ _ _
High level (default)	L O W ■ ■ ■ ■ _ _ H I G H _ _ _
Amplify level	L O W ■ ■ ■ ■ ■ ■ H I G H _ _ _

- (4) If the current receiver volume is not High, use the up or down arrow key to choose High.

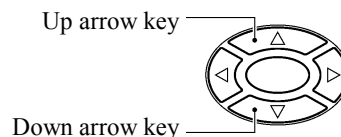

- (5) Press the **Fax Start** key.

The equipment enters the receiver volume adjustment mode and shows the PWM duty ratio at the right end of the LCD.
- (6) Adjust the receiver volume by using the **1**, **3**, **4**, or **6** key.
 - 1** key: Decrease 10H
 - 3** key: Increase 10H
 - 4** key: Decrease 1H
 - 6** key: Increase 1H
- (7) To escape from the receiver volume adjustment mode, press the **Set** key.

The LCD shows the "PWM SETTING." One second later, the LCD returns to the screen shown in step (3).
- (8) To return the equipment to the initial stage of the maintenance mode, press the **Stop** key.

5.3.9 Sensor Operational Check

■ Function

This function allows you to check whether the seven sensors (six sensors on European models)--document front sensor, document rear sensor, cover sensor, registration sensor, toner sensor, paper ejection sensor, and hook switch*--operate correctly.

(*European models have no hook switch.)

■ Operating Procedure

- (1) Press the **3** and **2** keys in this order in the initial stage of the maintenance mode. The equipment beeps 1100 Hz and 400 Hz tones cyclically through the following volumes for testing the speaker.

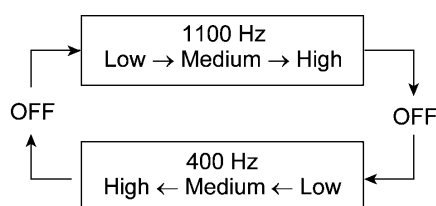

NOTE: To stop beeping, press the **Menu** key.

If the sensing status are as listed below, the LCD will show the following:

"DFDRCVRGPO TNHK" on American models

"DFDRCVRGPO TN" on European models

Given below is the relationship between the LCD indication, sensor names and sensor status.

LCD	Sensors	Sensing status
DF	Document front sensor	No document detected.
DR	Document rear sensor	No document detected.
CV	Cover sensor	Top cover closed.
RG	Registration sensor	No paper detected.
PO	Paper ejection sensor	No paper jam.
TN	Toner sensor	Toner detected.
HK	Hook switch*	On-hook state.

- (2) Change the detecting conditions (e.g., insert paper through the document sensors or the registration sensor(s), open the top cover, jam paper at the paper outlet, remove the toner cartridge, and lift up the handset*), and then check that the indication on the LCD changes according to the sensor states.
- (3) To stop this operation and return the equipment to the initial stage of the maintenance mode, press the **Stop** key.

5.3.10 Fine Adjustment of Scanning Start/End Position

■ Function

This function allows you to adjust the scanning start/end position.

■ Operating Procedure

- (1) Press the **5** and **4** keys in this order in the initial stage of the maintenance mode.

The "SCAN START ADJ." appears on the LCD. After two seconds, the current scanning position correction value appears.

You may adjust the correction value to 11 levels from +5 to -5 (mm).

- (2) To increase the correction value, press the left arrow key; to decrease it, press the right arrow key.

If you press the **Stop** key, the equipment returns to the initial stage of the maintenance mode without making change of the correction value.

- (3) Press the **Set** key.

The "ACCEPTED" appears on the LCD. After one second, the equipment returns to the initial stage of the maintenance mode.

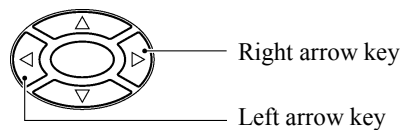
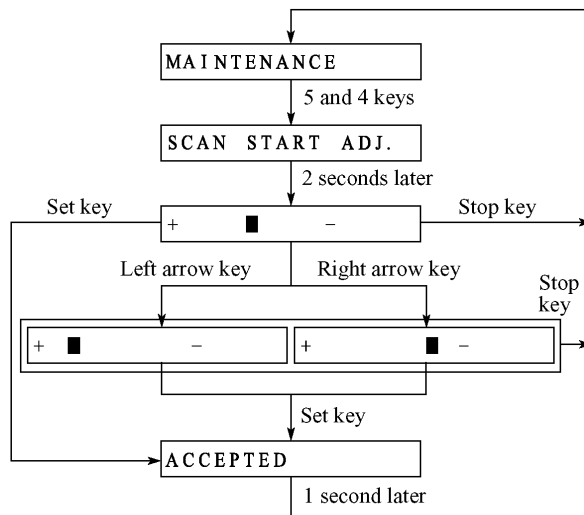

NOTE: The relationship between the scanning start/end positions and their correction values is shown below.

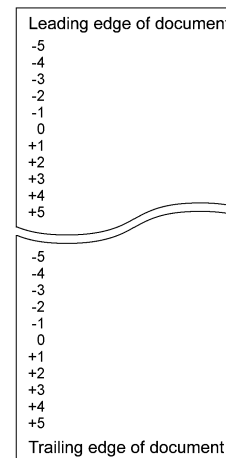

5.3.11 CIS Scanner Area Setting

■ Function

The equipment sets the CIS scanner area and stores it into the EEPROM.

■ Operating Procedure

- (1) Press the **5** key twice in the initial stage of the maintenance mode.

The "SCANNER AREA SET" will appear on the LCD.

The equipment checks and sets the area to be scanned.

If no error is noted, the equipment returns to the initial stage of the maintenance mode.

If any error is noted, the "SCANNER ERROR" will appear on the LCD. To return the equipment to the initial stage of the maintenance mode, press the **Stop** key.

5.3.12 EEPROM Customizing

■ Function

This function allows you to customize the EEPROM according to language, function settings, and firmware switch settings. The customizing codes list is given in Appendix 1.

NOTE: If you replace the main PCB, be sure to carry out this procedure.

■ Operating Procedure

- (1) Press the **7** and **4** keys in this order in the initial stage of the maintenance mode.

The current customizing code (e.g., 9101 in the case of MFC4800 USA version) appears.

- (2) Enter the desired customizing code (e.g., 0002 in the case of FAX2800 Canadian version).

The newly entered code appears.

***NOTE:** If a wrong 4-digit code is entered, the equipment will malfunction.*

- (3) Press the **Fax Start** key.

The equipment saves the setting and returns to the initial stage of the maintenance mode.

If you press the **Stop** key or no keys are pressed for one minute in the above procedure, the equipment stops the procedure and returns to the initial stage of the maintenance mode.

5.3.13 Display of the Equipment's Log Information

■ Function

The equipment may display the its log information on the LCD.

■ Operating Procedure

- (1) Press the **8** and **0** keys in this order in the initial stage of the maintenance mode.
The USB serial number appears on the LCD.
- (2) Press the **Fax Start** key. Each time the **Fax Start** key is pressed, one of the following log information items appears on the LCD in the order given below.
 - 1) Jam count, indicating how many times a paper jam has been occurred
 - 2) Page count, indicating how many pages the current drum has been printed
 - 3) Total page count, indicating how many pages the equipment has been printed since produced
 - 4) Drum count, indicating how many times the drum has been rotated
 - 5) Drum change count, indicating how many times drum replacement has been made
 - 6) Toner change count, indicating how many times toner replacement has been made
 - 7) Copy page count, indicating how many copies have been made
 - 8) PC print page count, indicating how many pages the equipment has been printed as an output device of the connected PC
 - 9) FAX page count, indicating how many received FAX pages have been printed
 - 10) Error code of the most recent machine error
 - 11) Error code of the most recent communications error
 - 12) ADF jam count, indicating how many times a document jam has been occurred
 - 13) ADF page count, indicating how many documents have been fed
- (3) To stop this operation and return to the equipment to the initial stage of the maintenance mode, press the **Stop** key.

5.3.14 Equipment Error Code Indication

■ Function

This function displays an error code of the last error on the LCD.

■ Operating Procedure

- (1) Press the **8** and **2** keys in this order in the initial stage of the maintenance mode.
The LCD shows the "MACHINE ERROR X X."
- (2) To stop this operation and return the equipment to the initial stage of the maintenance mode, press the **Stop** key.

5.3.15 Output of Transmission Log to the Telephone Line

■ Function

This function outputs the transmission log (that the equipment has stored about the latest transmission) to the telephone line. It allows the service personnel to receive the transmission log of the user's equipment at a remote location and use it for analyzing problems arising in the user's equipment.

■ Operating Procedure

- (1) If the user's equipment has a transmission-related problem, call the user's equipment at a remote location from your equipment.
- (2) If the line is connected, have the user perform the following:
 - 1) Press the **Menu**, **Receive Mode**, and **0** keys in this order.
 - 2) Press the **8** and **7** keys.

The above operation makes the user's equipment send CNG to your equipment for sending the transmission log.

- (3) If you hear the CNG sent from the user's equipment, press the **Fax Start** key of your equipment.

Your equipment will start to receive the transmission log from the user's equipment.

5.3.16 Cancellation of the Memory Security Mode (applicable to the European version only)

■ Function

This procedure can cancel the memory security mode. Use this procedure if the user forgets his/her password entered when setting the memory security mode so as not to exit from the memory security mode.

NOTE: Carrying out this procedure will lose passwords previously entered but retain FAX messages received in the memory security mode.

■ Operating Procedure

- (1) When the SECURE MODE is displayed on the LCD, press the **Menu** and **#** keys *at the same time*. Within two seconds, start to press the **2**, **7**, **9**, **0**, and **0** keys.

The memory security mode will be canceled and the equipment returns to the calendar clock screen.

CHAPTER 6

ERROR INDICATION AND TROUBLESHOOTING

CHAPTER 6 ERROR INDICATION AND TROUBLESHOOTING

CONTENTS

6.1	ERROR INDICATION.....	6-1
6.1.1	Equipment Errors	6-1
[1]	Error messages on the LCD	6-1
[2]	Error codes shown in the "MACHINE ERROR <u>X X</u> " message.....	6-5
6.1.2	Communications Errors.....	6-7
6.2	TROUBLESHOOTING.....	6-17
6.2.1	Introduction.....	6-17
6.2.2	Precautions	6-17
6.2.3	Checking prior to Troubleshooting	6-17
6.2.4	Troubleshooting Procedures	6-19
[1]	Control panel related.....	6-19
[2]	Telephone related	6-19
[3]	Communications related	6-20
[4]	Paper/document feeding related.....	6-20
[5]	Print-image related.....	6-21
	<u>Location of High-voltage Contacts and Grounding Contacts</u>	6-28

6.1 ERROR INDICATION

To help the user or the service personnel promptly locate the cause of a problem (if any), the facsimile equipment incorporates the self-diagnostic functions which display error messages for equipment errors and communications errors.

For the communications errors, the equipment also prints out the transmission verification report and the communications list.

6.1.1 Equipment Errors

If an equipment error occurs, the facsimile equipment emits an audible alarm (continuous beeping) for approximately 4 seconds and shows the error message on the LCD. For the error messages, see [1] below.

To display detailed error information, use the maintenance-mode function code 82 described in CHAPTER 5, Subsection 5.3.14 (that is, make the equipment enter the maintenance mode and then press the **8** and **2** keys). Following the MACHINE ERROR, one of the error codes listed in [2] will appear on the LCD.

[1] Error messages on the LCD

Messages on the LCD	Probable Cause
CHANGE DRUM SOON	The service life of the drum unit will expire soon. This message appears for one minute. (You can turn this message indication on or off by the maintenance-mode function code 10, WSW31, selector 8. Refer to Appendix 2.)
CHECK ORIGINAL Remove original, and then press STOP KEY. (These messages appear alternately.) (See NOTE below.) or CHECK DOCUMENT Remove document, then press STOP KEY. (These messages appear alternately.)	<ul style="list-style-type: none"> ■ Document jam <ol style="list-style-type: none"> (1) The document length exceeds the limitation (400 or 90 cm) registered by firmware switch WSW16. (Refer to Appendix 2.) (Both the document front and rear sensors stay ON after the document has been fed by the registered length.) (2) The document rear sensor detects no trailing edge of a document after the document has been fed by 400 cm. (The document rear sensor stays ON even after the document has been fed when the document front and rear sensors were OFF and ON, respectively.)

NOTE: This message appears in North American models.

Messages on the LCD	Probable Cause
<p>CHECK ORIGINAL Remove original, and then press STOP KEY. (These messages appear alternately.) (See NOTE below.) or CHECK DOCUMENT Remove document, then press STOP KEY. (These messages appear alternately.)</p>	<p>■ Document loading error</p> <p>(1) The document rear sensor detects no leading edge of a document within 10 seconds from the start of document loading operation. (The document rear sensor stays OFF even after the document has been fed when the document front sensor was ON.)</p> <p>(2) The loaded document is too short. (Since the document is shorter than the distance between the document front and rear sensors, the document front sensor is turned OFF before the document rear sensor is turned ON.)</p>
<p>CHECK DRUM UNIT Open cover, then reinstall drum unit. (These messages appear alternately.)</p>	<p>No drum unit is loaded.</p>
<p>CHECK PAPER Reload paper by using lever, then press FAX START. (These messages appear alternately.)</p>	<p>Even after paper pick-up operation, the registration sensor does not detect paper.</p>
<p>CHECK PAPER SIZE Reload correct paper, then press FAX START. (These messages appear alternately.)</p>	<p>The registration sensor detects that paper shorter than the specified length has been fed. (This message appears only when a received message is printed.)</p>
<p>CLEAN UP SCANNER</p>	<p>In the scanning compensation data list printed by the maintenance-mode function code 05, less than fifty percent of the white level data is faulty. (This message may appear only in the maintenance mode.)</p>
<p>COOLING DOWN WAIT FOR A WHILE (These messages appear alternately.)</p>	<p>The controller, which monitors the internal resistance of toner thermistor, has detected that the toner temperature exceeded the specified level. If the temperature exceeds the preset level, recording is no longer possible. If the toner temperature drops, the equipment will be automatically recovered from the error state.</p>

NOTE: This message appears in North American models.

Messages on the LCD	Probable Cause
<p>COVER OPEN PLS CLOSE COVER</p> <p>(These messages appear alternately.)</p>	<p>The cover sensor detects that the top cover is not closed.</p>
<p>MACHINE ERROR XX Unplug machine, then call Brother.</p> <p>(These messages appear alternately.)</p>	<p>"XX" indicates an error code. Refer to [2] on pages 6-5 and 6-6.</p>
<p>PAPER JAM Open cover, then remove jammed paper.</p> <p>(These messages appear alternately.)</p>	<p>Paper jam</p> <ol style="list-style-type: none"> (1) The registration sensor detects no paper within the specified time length after the start of paper pulling-in. (2) The registration sensor has been ON for less than the specified time length (paper of approx. 3.15" long) or for more than the specified time length (paper of approx. 16" long). (3) When the equipment is switched on or the top cover is opened and then closed, the registration sensor or paper ejection sensor is ON. (4) The paper ejection sensor sticks to ON. (5) The paper ejection sensor does not come ON within the specified time length after the registration sensor has come ON. (6) The paper ejection sensor is kept ON after the specified time length although the registration sensor has come ON.
<p>PLS OPEN COVER</p>	<p>To display the relating detailed error code, use maintenance-mode function code 82. (Refer to CHAPTER 5, Subsection 5.3.14.)</p> <p>If this message appears, open and close the top cover. The message may disappear if opening/closing the top cover removes the error. If the error persists, the "MACHINE ERROR XX" will appear.</p>
<p>SCANNER ERROR</p>	<p>In the scanning compensation data list printed by the maintenance-mode function code 05, fifty percent or more of the white level data is faulty.</p> <p>(This message may appear only in the maintenance mode.)</p>

Messages on the LCD	Probable Cause
<p>TONER EMPTY</p> <p>Open cover, then replace new toner cartridge.</p> <p>(These messages appear alternately.)</p>	<p>The toner sensor has detected that there is no toner in the cartridge or that no toner cartridge is loaded. If this message appears, recording is no longer possible.</p>
<p>TONER LOW</p>	<p>The toner sensor has detected that there is not enough toner.</p>

If only an alarm beep is heard without any message on the LCD when the equipment is powered up, the ROM or RAM will be defective.

[2] Error codes shown in the "MACHINE ERROR X X" message

Error Code <u>X X</u> (Hex.)	Error factor
(71	Polygon motor does not synchronize with the reference clock.)
(72	Cannot detect Beam Detect signal.)
(73	No toner cartridge loaded.)
(74	Toner empty.)
(75	In-casing temperature error.)
(76	Heater harness disconnected or broken. Or heater thermistor harness disconnected or broken when the power is turned on, the top cover is opened and closed, or the machine exits from the sleep mode.)
(77	Power turned off and on at the occurrence of error 76 or 78.)
(78	Heater thermistor short-circuited. Or heater thermistor harness disconnected or broken when the machine is on standby.)
(79	Toner thermistor harness disconnected or broken.)
(80	Paper size setting error.)
(82	Paper feeding error.)
(83	Paper jam. The registration sensor remains ON.)
(84	Paper jam. The paper ejection sensor remains ON.)
(88	Paper jam. Even after the registration sensor has gone OFF, the paper ejection sensor still stays OFF.)
(A1	Top cover opened.)
(A2	Document too long to scan.)
(A3	Document not detected by the document rear sensor.)
(A4	50% or more faulty of white level data.)
(A7	One-line feeding timeout error.)
(A8	One-line scanning timeout error.)
(A9	Abnormal scanning reference voltage.)
(AC	Less than 50% faulty of white level data.)

Error codes in parentheses do not appear in the "MACHINE ERROR X X", since those errors are displayed as messages described in "[1] Error messages on the LCD." In the maintenance mode (Function code 82), those error codes may be displayed.

Error Code <u>X X</u> (Hex.)	Error factor
(B9	Light emission intensity error of the LED array.)
(D5	The MODEM fails to complete the command transmission sequence.)
(E4	Out of recording paper.)
E6	Write error in EEPROM.
(E8	Data scanning error during transmission.)
(EA	Document removed in phase B.)
(F5	EOL not found in page memory transmission mode.)
(F6	PC interface error.)

Error codes in parentheses do not appear in the "MACHINE ERROR X X", since those errors are displayed as messages described in "[1] Error messages on the LCD." In the maintenance mode (Function code 82), those error codes may be displayed.

6.1.2 Communications Errors

If a communications error occurs, the facsimile equipment

- ① emits an audible alarm (intermittent beeping) for approximately 4 seconds,
- ② displays the corresponding error message, and
- ③ prints out the transmission verification report if the equipment is in sending operation.

■ **Definition of Error Codes on the Communications List**

(1) Calling

Code 1	Code 2	Causes
10	08	Wrong number called.
10	20	Retrieval file error.
10	21	Image data entry error.
11	01	No dial tone detected before start of dialing.
11	02	Busy tone detected before dialing.
11	03	2nd dial tone not detected.
11	05	No loop current detected.*
11	06	Busy tone detected after dialing or called.
11	07	No response from the remote station in sending.
11	10	No tone detected after dialing.
17	07	No response from the calling station in receiving.
1A	01	Calling impossible due to memory full.

*Available in German versions only.

(2) Command reception

Code 1	Code 2	Causes
20	01	Unable to detect a flag field.
20	02	Carrier was OFF for 200 ms or longer.
20	03	Abort detected ("1" in succession for 7 bits or more).
20	04	Overrun detected.
20	05	A frame for 3 seconds or more received.
20	06	CRC error in answerback.
20	07	Undefined command received.
20	08	Invalid command received.
20	09	Command ignored once for document setting or for dumping-out at turn-around transmission.
20	0A	T5 timeout error
20	0B	CRP received.

Code 1	Code 2	Causes
20	0C	EOR and NULL received.
20	0D	Effective command not received.
20	10	Unable to reserve a command receiver memory.
20	11	Image data file error.

(3) Compatibility [checking the NSF and DIS]

Code 1	Code 2	Causes
32	01	Remote terminal only with V.29 capability in 2400 or 4800 bps transmission.
32	02	Remote terminal not ready for polling.
32	10	Remote terminal not equipped with password function or its password switch OFF.
32	11	Remote terminal not equipped with or not ready for confidential mail box function.
32	12	Remote terminal not equipped with or not ready for relay broadcasting function.
32	13	No confidential mail in the remote terminal.
32	14	The available memory space of the remote terminal is less than that required for reception of the confidential or relay broadcasting instruction.

(4) Instructions received from the remote terminal [checking the NSC, DTC, NSS, and DCS]

Code 1	Code 2	Causes
40	02	Illegal coding system requested.
40	03	Illegal recording width requested.
40	05	ECM requested although not allowed.
40	06	Polled while not ready.
40	07	No document to send when polled.
40	10	Nation code or manufacturer code not coincident.
40	11	Unregistered group code entered for relay broadcasting function, or the specified number of broadcasting subscribers exceeding the limit.
40	12	Retrieval attempted when not ready for retrieval.
40	13	Polled by any other manufacturers' terminal while waiting for secure polling.
40	17	Invalid resolution selected.

(5) Command reception [checking the NSF and DIS after transmission of NSS and DCS]

Code 1	Code 2	Causes
50	01	Vertical resolution capability changed after compensation of background color.

(6) ID checking

Code 1	Code 2	Causes
63	01	Password plus "lower 4 digits of telephone number" not coincident.
63	02	Password not coincident.
63	03	Polling ID not coincident.
63	04	Entered confidential mail box ID uncoincident with the mail box ID.
63	05	Relay broadcasting ID not coincident.
63	06	Entered retrieval ID uncoincident with that of the mail box ID.

(7) DCN reception

Code 1	Code 2	Causes
74		DCN received.

(8) TCF transmission/reception

Code 1	Code 2	Causes
80	01	Fallback impossible.

(9) Signal isolation

Code 1	Code 2	Causes
90	01	Unable to detect video signals and commands within 6 seconds after CFR is transmitted.
90	02	Received PPS containing invalid page count or block count.

(10) Video signal reception

Code 1	Code 2	Causes
A0	03	Error correction sequence not terminated even at the final transmission speed for fallback.
A0	11	Receive buffer empty. (5-second time-out)
A0	12	Receive buffer full during operation except receiving into memory.
A0	13	Decoding error continued on 500 lines.
A0	14	Decoding error continued for 10 seconds.
A0	15	Timeout: Five seconds or more for one-line transmission.
A0	16	RTC not found and carrier OFF signal detected for 6 seconds.
A0	17	RTC found but no command detected for 60 seconds.
A0	18	Receive buffer full during receiving into memory.
A0	19	Unable to obtain compressed image data to be sent in phase C.
A8	01	RTN, PIN, or ERR received at the calling terminal.*
A9	01	RTN, PIN, or ERR received at the called terminal.*

* Available in German versions only

(11) General communications-related

Code 1	Code 2	Causes
B0	02	Unable to receive the next-page data.
B0	03	Unable to receive polling even during turn-around transmission due to call reservation.
B0	04	PC interface error.
BF	01	Transmission canceled by pressing the Stop key (before completion of the G3 FAX negotiation).
BF	02	Transmission canceled by pressing the Stop key (after completion of the G3 FAX negotiation).
BF	03	Transmission canceled due to a scanning error.

(12) Transmission in V. 34 mode

Code 1	Code 2	Causes
C0	01	No common modulation mode or failed to poll.
C0	02	Unable to detect JM.
C0	03	Unable to detect CM.
C0	04	Unable to detect CJ.
C0	10	Cannot finish V. 34 negotiation or training.
C0	11	Modem error detected during V. 34 negotiation or training. (For modem error details, refer to the table given on the next page.)
C0	20	Modem error detected during sending of commands. (For modem error details, refer to the table given on the next page.)
C0	21	Modem error detected during receiving of commands. (For modem error details, refer to the table given on the next page.)
C0	22	Control channel connection time-out.
C0	30	Modem error detected during sending of video signals. (For modem error details, refer to the table given on the next page.)
C0	31	Modem error detected during receiving of video signals. (For modem error details, refer to the table given on the next page.)

Modem error details (Code 3)

Code 3	Causes
21	Timeout waiting for INFO0.
22	Checksum error in INFO0.
23	Timeout waiting for tone A or B.
24	Timeout waiting for first phase reverse.
25	Timeout waiting for probing cut-off tone.
26	Timeout waiting for second phase reverse.
27	Timeout waiting for end of probing.
28	Timeout waiting for third phase reverse.
29	Timeout waiting for INFO1.
2A	Checksum error in INFO1.
2B	Tone detected preceding INFO0.
2C	Unexpected INFO0 detected.
31	Timeout waiting for turning off the receive control channel.
91	Error occurred in the first CC train.
92	Timeout waiting for PPh.
93	Tone A/B detected in the CC retrain.
94	Timeout waiting for ALT.
95	ACh found.
96	FED turned off during reception of CC data.
97	Timeout waiting for turning off the CC.
A1	Retraining forced for problems not fixed in phase 2.
B0	Problem with S-sequence of HDX-resync.
B1	FED turned off in the S-sequence of HDX-resync.
B2	S-sequence finished before prediction in HDX-resync.
B3	Timeout waiting for S-Sbar in HDX-resync.
B4	Timeout waiting for S-Sbar in HDX-resync.
B5	Timeout waiting for S in HDX-resync.
B6	Timeout waiting for synchronization with PP.
C0	Problem with S-sequence in phase 3.
C1	FED turned off in the S-sequence in phase 3.

Code 3	Causes
C2	S-sequence finished before prediction in phase 3.
C3	Timeout waiting for S-Sbar in phase 3.
C4	Timeout waiting for S-Sbar in phase 3.
C5	Timeout waiting for S in phase 3.
C7	Training after TRN failure.
D0	Problem with S-sequence in phase 4.
D1	FED turned off in S-sequence in phase 4.
D2	S-sequence finished before prediction in phase 4.
D3	Timeout waiting for S-Sbar in phase 4.
D4	Timeout waiting for S-Sbar in phase 4.
D5	Timeout waiting for S in phase 4.
D6	Timeout waiting for MP.
D8	Timeout waiting for E.
DA	Timed out in re-negotiation of the transmitter rate.
DB	Timed out in the transmitter MPh.
E2	Retraining detected in phase 2.
E3	Retraining detected in phase 3.
E4	Retraining detected in phase 4.
FE	DTR turned off during retraining.
FF	Tx set-abort flag.
71	Did not write onto the first mapping frame.

(13) Maintenance mode

Code 1	Code 2	Causes
E0	01	Failed to detect 1300 Hz signal in burn-in operation.
E0	02	Failed to detect PB signals in burn-in operation.
E0	03	Failed to detect commands from the RS-232C in burn-in operation.

(14) Equipment error

Code 1	Code 2	Causes
FF	00	Burn-in operation canceled by pressing the Stop key.
FF	FF	Unrecoverable MODEM error.

6.2 TROUBLESHOOTING

6.2.1 Introduction

This section gives the service personnel some of the troubleshooting procedures to be followed if an error or malfunction occurs with the facsimile equipment. It is impossible to anticipate all of the possible problems which may occur in future and determine the troubleshooting procedures, so this section covers some sample problems. However, those samples will help service personnel pinpoint and repair other defective elements if he/she analyzes and examines them well.

6.2.2 Precautions

Be sure to observe the following to prevent the secondary troubles from happening:

- (1) Always unplug the AC power cord from the outlet when removing the covers and PCBs, adjusting the mechanisms, or conducting continuity testing with a circuit tester.
- (2) When disconnecting the connectors, do not pull the lead wires but hold the connector housings.
- (3)
 - Before handling the PCBs, touch a metal portion of the machine to discharge static electricity charged in your body.
 - When repairing the PCBs, handle them with extra care.

After repairing the defective section, be sure to check again if the repaired section works correctly. Also record the troubleshooting procedure so that it would be of use for future trouble occurrence.

6.2.3 Checking prior to Troubleshooting

Prior to proceeding to the troubleshooting procedures given in Subsection 6.2.4, make the following initial checks:

Environmental conditions

Check that:

- (1) The machine is placed on a flat, firm surface.
- (2) The machine is used in a clean environment at or near normal room temperature (10°C to 32.5°C) with normal relative humidity (20 to 80%).
- (3) The machine is not subjected to rapid change of the ambient temperature. (Moving the machine from a cold place to warm place will cause condensation inside the machine. If it takes place, leave the machine in the warm place for approx. two hours before turning on the power.) Powering on the machine with dew condensation will result in damaged electronic devices.
- (4) The machine is not exposed to direct sunlight or harmful gases.

Power requirements

Check that:

- (1) The power supply specified on the rating plate located on the bottom of the machine is used.
The supply voltage stays within the rating $\pm 10\%$.
- (2) Each voltage level on AC input lines and DC lines is correct.
- (3) All cables and harnesses are firmly connected.
- (4) None of the fuses are blown.

Recording paper

Check that:

- (1) A recommended type of recording paper is used.
- (2) The recording paper is not dampened.

6.2.4 Troubleshooting Procedures

[1] Control panel related

Trouble	Check:
(1) LCD shows nothing.	<ul style="list-style-type: none"> • Panel-main harness between the main PCB and the control panel PCB • Control panel PCB • Low-voltage power supply PCB • Main PCB • LCD
(2) Control panel inoperative.	<ul style="list-style-type: none"> • Panel-main harness between the main PCB and the control panel PCB • Control panel PCB • FPC key • Main PCB

[2] Telephone related

Trouble	Check:
(1) No phone call can be made.	<ul style="list-style-type: none"> • FPC key • Control panel PCB • NCU PCB • Main PCB
(2) Speed dialing or one-touch dialing will not work.	<ul style="list-style-type: none"> • Ordinary dialing function (other than the speed and one-touch dialing) <p>If it works normally, check the main PCB; if not, refer to item (1) above.</p>
(3) Speaker silent during on-hook dialing.	<ul style="list-style-type: none"> • Ordinary dialing function (other than the on-hook dialing with the hook key) <p>If it works normally, proceed to the following checks; if not, refer to item (1) above.</p>
(4) Dial does not switch between tone and pulse.	<ul style="list-style-type: none"> • Main PCB • NCU PCB
(5) Telephone does not ring.	<ul style="list-style-type: none"> • Speaker • NCU PCB • Main PCB

[3] Communications related

Trouble	Check:
(1) No tone is transmitted.	<ul style="list-style-type: none">• Main PCB• NCU PCB



[4] Paper/document feeding related

Trouble	Check:
(1) Neither "COPY: PRESS COPY" nor "FAX: NO. & START" message appears although documents are set.	<ul style="list-style-type: none">• Sensors by using the maintenance-mode function code 32. (Refer to CHAPTER 5, Subsection 5.3.9.)• Document front sensor actuator and document rear sensor actuator• Main PCB
(2) Document not fed.	<ul style="list-style-type: none">• ADF and its related sections• Scanner motor and its harness• Document feed roller and its related gears• Main PCB
(3) Document double feeding	<ul style="list-style-type: none">• ADF parts• Nip-related parts
(4) Recording paper not fed.	<ul style="list-style-type: none">• ASF• Drum unit• Heat-fixing unit• Drive gear ASSY• Main PCB
(5) Recording paper double feeding	<ul style="list-style-type: none">• Separation pad on the ASF

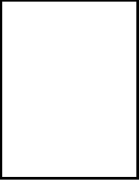

[5] Print-image related

If the received or sent image has any problem, first make a copy with the facsimile equipment.

If the copied image is normal, the problem may be due to the remote terminal; if it is abnormal, proceed to the following checks:

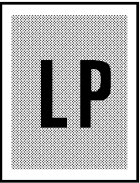

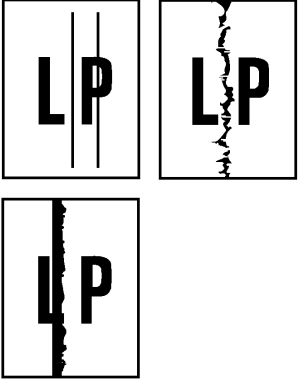
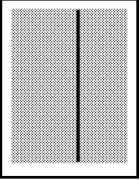
Trouble	Action to be taken
<p>(1) Completely blank</p> 	<p><u>At the scanner</u></p> <p>Check the following components:</p> <ul style="list-style-type: none"> - CIS harness - Main PCB - CIS unit <p><u>At the printer side</u></p> <ul style="list-style-type: none"> • Clean the high-voltage contacts for the developer roller on the drum unit, main cover, and high-voltage power supply PCB. (Contacts ③ in the illustration given on page 6-28) • Clean the grounding contacts on the drum unit, main cover, and high-voltage power supply PCB. (Contacts ① in the illustration given on page 6-28) • Check that the grounding plate is sandwiched between the contact plate and gear drive unit. (Refer to CHAPTER 4, Subsection 4.1.21, page 4-36.) • Replace the toner cartridge. • Replace the drum unit. • Check the connection of the laser flat cable on the main PCB. • Replace the main PCB. • Replace the laser unit. • Replace the high-voltage power supply PCB.
<p>(2) All black</p> 	<p><u>At the scanner</u></p> <p>Check the following components:</p> <ul style="list-style-type: none"> - CIS harness - CIS unit - Main PCB <p><u>At the printer side</u></p> <ul style="list-style-type: none"> • Clean the high-voltage contacts for the grid and charger on the drum unit, main cover, and high-voltage power supply PCB. (Contacts ⑤ and ⑥ in the illustration given on page 6-28) • Clean the charger (corona wires) itself. • Check the connection of the laser flat cable on the main PCB. • Replace the drum unit. • Replace the high-voltage power supply PCB. • Replace the main PCB.

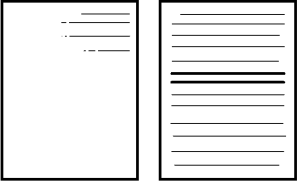

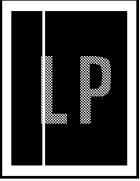
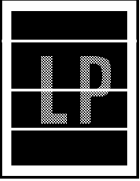
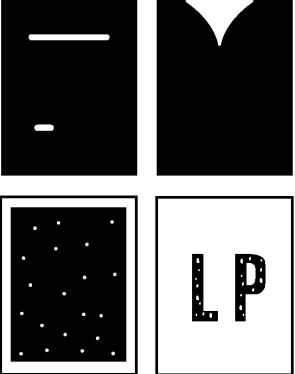
Trouble	Action to be taken
<p>(3) Light</p> 	<p><u>At the scanner</u></p> <p>Check the following components:</p> <ul style="list-style-type: none"> - CIS unit - Main PCB <p><u>At the printer side</u></p> <ul style="list-style-type: none"> • Replace the toner cartridge with a new one and print 4 to 5 pages. If the problem persists, proceed to the next step. • Remove the toner cartridge and start printing. If printing takes place, clean the toner sensors (LED and light-receiver), check the sensor harnesses, and then replace the toner sensor PCBs. • Clean the high-voltage contacts for the transfer roller on the drum unit, main cover, and high-voltage power supply PCB. (Contacts ③ in the illustration given on page 6-28) • Clean the high-voltage contacts for the developer roller on the drum unit, main cover, and high-voltage power supply PCB. (Contacts ⑦ in the illustration given on page 6-28) • Clean the grounding contacts on the drum unit, gear drive unit, and main cover. (Contacts ① and ② in the illustration given on page 6-28) • Check the connection of the high-voltage power flat cable on the main PCB and high-voltage power supply PCB. • Replace the drum unit. • Replace the high-voltage power supply PCB. • Replace the main PCB. • Replace the laser unit.
<p>(4) Dark</p> 	<p><u>At the scanner</u></p> <p>Check the following components:</p> <ul style="list-style-type: none"> - CIS unit - Main PCB <p><u>At the printer side</u></p> <ul style="list-style-type: none"> • Slide the wire cleaner to clean the corona wire inside the drum unit. • Clean the high-voltage contacts for the grid and charger on the drum unit, main cover, and high-voltage power supply PCB. (Contacts ⑤ and ⑥ in the illustration given on page 6-28) • Replace the toner cartridge. • Replace the drum unit. • Replace the high-voltage power supply PCB. • Replace the main PCB.

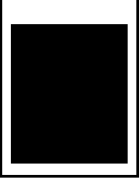
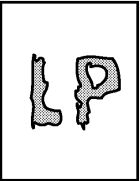
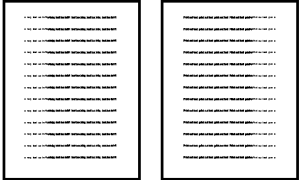
Trouble	Action to be taken
<p>(5) Black and blurred vertical stripes or band</p> 	<p><u>At the scanner</u></p> <p>Check the following components:</p> <ul style="list-style-type: none"> - CIS unit <p><u>At the printer side</u></p> <ul style="list-style-type: none"> • Clean the paper path which may be contaminated with toner. • Slide the wire cleaner to clean the corona wire inside the drum unit. • Make sure that the wire cleaner is returned to its home position. • Replace the toner cartridge. • Replace the drum unit. • Replace the heat-fixing unit.
<p>(6) Black vertical streaks on gray background</p> 	<p><u>At the printer side</u></p> <ul style="list-style-type: none"> • Clean the laser beam window (glass) on the laser unit. • Replace the laser unit.
<p>(7) Black and blurred horizontal stripes</p> 	<p><u>At the printer side</u></p> <ul style="list-style-type: none"> • Slide the wire cleaner to clean the corona wire inside the drum unit. • If they appear at 94-mm or 17-mm intervals, replace the drum unit. • If they appear at 54-mm intervals, replace the heat-fixing unit. • Replace the high-voltage power supply PCB.
<p>(8) Horizontal lines</p> 	<p><u>At the printer side</u></p> <ul style="list-style-type: none"> • Check the connection between the right end of the paper feed roller and the grounding wire. (Contact ⑦ in the illustration given on page 6-28.)

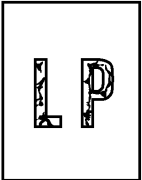
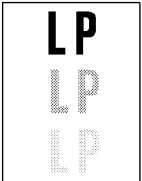
Trouble	Action to be taken
<p>(9) White vertical streaks</p> 	<p><u>At the scanner</u></p> <p>Check the following components:</p> <ul style="list-style-type: none"> - CIS unit <p><u>At the printer side</u></p> <ul style="list-style-type: none"> • Clean the laser beam window on the laser unit. • Replace the toner cartridge. • Replace the drum unit.
<p>(10) White horizontal stripes</p> 	<p><u>At the printer side</u></p> <ul style="list-style-type: none"> • Replace the drum unit.
<p>(11) Dropout, white spots, or hollow print</p> 	<p><u>At the printer side</u></p> <ul style="list-style-type: none"> • Check the connection of the high-voltage power flat cable on the main PCB and high-voltage power supply PCB. • Replace the toner cartridge. • Gently wipe off the surface of the photo-sensitive drum with a cotton swab. • Replace the drum unit. • Replace the high-voltage power supply PCB.

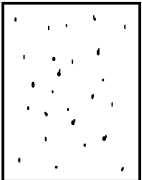
Trouble	Action to be taken
<p>(12) Faulty image registration (Leading edge of image starts too late on paper)</p> 	<p><u>At the printer side</u></p> <ul style="list-style-type: none"> • Instruct the user not to load paper exceeding the limit in the ASF. • Instruct the user to use the recommended types of paper. • Replace the ASF. • Check the position of the registration sensor. • Replace the gear drive unit.
<p>(13) Image distortion or improper image alignment</p> 	<p><u>In communications</u></p> <p>Check the following components:</p> <ul style="list-style-type: none"> - Error code displayed. (Refer to Section 6.1, "ERROR INDICATION" in this chapter.) - NCU PCB - Main PCB <p><u>At the scanner</u></p> <p>Check the following components:</p> <ul style="list-style-type: none"> - Document take-in roller, separation roller, and their related sections - Document feed roller and its related gears - Scanner motor and its harness - Main PCB <p><u>At the printer side</u></p> <ul style="list-style-type: none"> • Check that the laser unit is secured with the screws without looseness. • Check the connection of the polygon motor harness. • Check the connection of the laser flat cable on the main PCB. • Replace the laser unit.
<p>(14) Blurred at either side</p> 	<p><u>At the printer side</u></p> <ul style="list-style-type: none"> • Check that the equipment is placed on a flat surface. • Shake the toner cartridge horizontally. If the problem persists, replace it. • Clean the laser beam window (glass) on the laser unit. • Replace the laser unit.

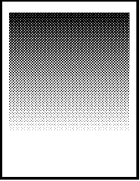
Trouble	Action to be taken
<p>(15) Dirt back of paper</p> 	<p><u>At the printer side</u></p> <ul style="list-style-type: none"> • Clean the pressure roller in the heat-fixing unit. Replace the heat-fixing unit. • Replace the drum unit. • Replace the high-voltage power supply PCB.
<p>(16) Poor fixing</p> 	<p><u>At the printer side</u></p> <ul style="list-style-type: none"> • Instruct the user to use paper of the recommended weight (16 to 42 lb./m²). • Clean the toner sensors (LED and light-receiver). • Replace the toner cartridge. • Replace the drum unit. • Check the fitting of the heater thermistor. Replace the heat-fixing unit. • Replace the low-voltage power supply PCB.
<p>(17) Ghost</p> 	<p><u>At the printer side</u></p> <ul style="list-style-type: none"> • Instruct the user to use paper of the recommended weight (16 to 42 lb./m²). • Replace the drum unit. • Replace the high-voltage power supply PCB.
<p>(18) Black spots</p> 	<p><u>At the printer side</u></p> <ul style="list-style-type: none"> • Gently wipe off the surface of the photo-sensitive drum with a cotton swab. • Replace the drum unit. • Replace the heat-fixing unit. • Replace the high-voltage power supply PCB.
<p>(19) Light rain</p> 	<p><u>At the printer side</u></p> <ul style="list-style-type: none"> • Replace the drum unit. • Replace the high-voltage power supply PCB.

Trouble	Action to be taken
<p>(20) Fading (black to white)</p> 	<p><u>At the printer side</u></p> <ul style="list-style-type: none"> • Replace the toner cartridge. • Replace the high-voltage power supply PCB.
<p>(21) Gray background</p> 	<p><u>At the printer side</u></p> <ul style="list-style-type: none"> • Instruct the user to use paper of the recommended weight (16 to 42 lb./m²). • Clean the toner sensors (LED and light-receiver). • Check the toner sensor harnesses. • Replace the toner cartridge. • Replace the drum unit. • Replace the high-voltage power supply PCB.
<p>(22) Toner specks</p> 	<p><u>At the printer side</u></p> <ul style="list-style-type: none"> • Instruct the user to use paper of the recommended weight (16 to 42 lb./m²). • Replace the toner cartridge. • Replace the drum unit.

Location of High-voltage Contacts and Grounding Contacts

Grounding Contacts

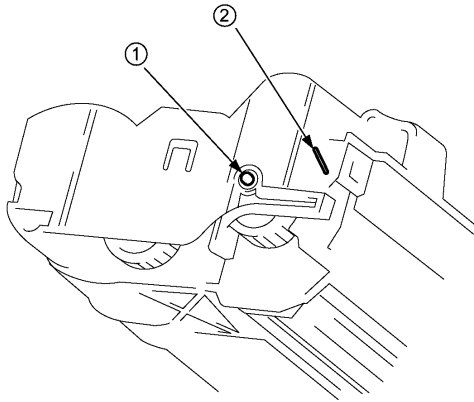

High-voltage Contacts

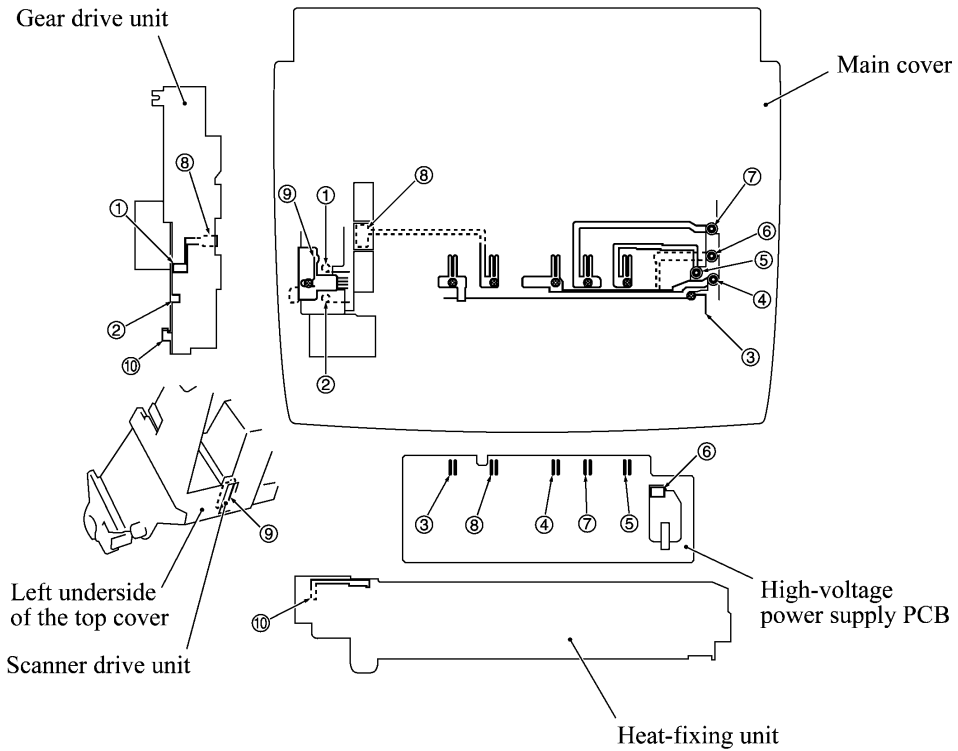
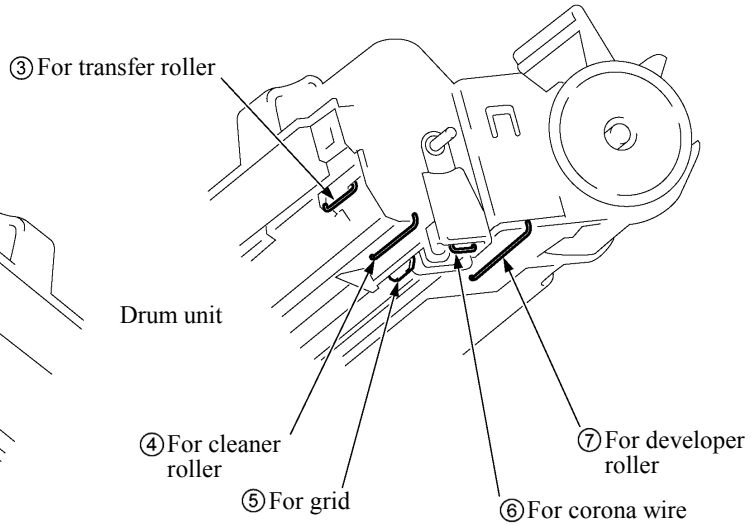

**FAX2800/FAX2900/FAX3800/MFC4800
FAX8070P/MFC9030/MFC9070**

Appendix 1. EEPROM Customizing Codes

EEPROM CUSTOMIZING CODES

This function allows you to customize the EEPROM according to language, function settings, and firmware switch settings.

■ Operating Procedure

- (1) To make the equipment enter the maintenance mode, press the **Menu**, *, **2**, **8**, **6**, and **4** keys in this order. |← Within 2 seconds →|

The equipment beeps for approx. one second and displays "■■ MAINTENANCE ■■■" on the LCD.

- (2) Press the **7** and **4** keys in this order in the initial stage of the maintenance mode.
The current customizing code (e.g., 9101 in the case of MFC4800 U.S.A. version) appears.

- (3) Enter the desired customizing code (e.g., 0002 in the case of FAX2800 Canadian version).
The newly entered code appears.

***NOTE:** If a wrong 4-digit code is entered, the equipment will malfunction.*

- (4) Press the **Fax Start** key.

The equipment saves the setting and returns to the initial stage of the maintenance mode.

If you press the **Stop** key or no keys are pressed for one minute in the above procedure, the equipment stops the procedure and returns to the initial stage of the maintenance mode.

■ **EEPROM Customizing Codes List**

Versions	Model			
	FAX2800 (FAX2850)	FAX2900	FAX3800	MFC4800
U.S.A.	9001	9201	9001	9101
CANADA	0002	0202	0002	0102
AUSTRALIA	0006	---	---	0106
NEW ZEALAND	0027	---	---	0127
ASIA (SINGAPORE)	0040	---	---	0140
HONG KONG	0040	---	---	---
ARGENTINA	---	---	---	0101
BRAZIL	---	---	---	9101
KOREA	0040	---	---	---

Versions	Model		
	FAX8070P	MFC9030	MFC9070
GERMANY	0003	0203	0103
U.K.	0004	0204	0104
FRANCE	0005	0205	0105
NORWAY	0007	---	0107
BELGIUM	0008	---	0108
NETHERLANDS	0009	---	0109
SWITZERLAND	0010	---	0110
IRELAND	0004	---	0104
FINLAND	0012	---	0112
DENMARK	0013	---	0113
AUSTRIA	0003	---	0103
SPAIN	0015	---	0115
ITALY	0016	---	0116
SOUTH AFRICA	0004	---	0104
SWEDEN	0026	---	0126
POLAND	0039	---	0139
EURO GENERIC	---	---	0150

**FAX2800/FAX2900/FAX3800/MFC4800
FAX8070P/MFC9030/MFC9070**

Appendix 2. Firmware Switches (WSW)

WSW No.	Function	Reference Page
WSW01	Dial pulse setting	2
WSW02	Tone signal setting	3
WSW03	PABX mode setting	4
WSW04	TRANSFER facility setting	6
WSW05	1st dial tone and busy tone detection	7
WSW06	Pause key setting and 2nd dial tone detection	9
WSW07	Dial tone setting 1	11
WSW08	Dial tone setting 2	12
WSW09	Protocol definition 1	13
WSW10	Protocol definition 2	14
WSW11	Busy tone setting	15
WSW12	Signal detection condition setting	16
WSW13	Modem setting	17
WSW14	AUTO ANS facility setting	18
WSW15	REDIAL facility setting	19
WSW16	Function setting 1	20
WSW17	Function setting 2	21
WSW18	Function setting 3	22
WSW19	Transmission speed setting in V. 17 mode	23
WSW20	Overseas communications mode setting	24
WSW21	TAD setting 1	25
WSW22	ECM setting	25
WSW23	Communications setting	26
WSW24	TAD setting 2	27
WSW25	TAD setting 3	28
WSW26	Function setting 4	29
WSW27	Function setting 5	30
WSW28	Function setting 6	31
WSW29	Function setting 7	32
WSW30	Function setting 8	32
WSW31	Function setting 9	33
WSW32	Function setting 10	34
WSW33	Function setting 11	34
WSW34	Function setting 12	35
WSW35	Function setting 13	35
WSW36	Function setting 14	36
WSW37	Function setting 15	37
WSW38	Function setting 16 in V. 34 mode	38
WSW39	Transmission speed setting in V. 34 mode	39
WSW40	Function setting 17 in V. 34 mode	40
WSW41	CCD fluorescent lamp and modem attenuator in V. 34 mode	41
WSW42	Function setting 18	42
WSW43	Function setting 19	42
WSW44	Speeding up scanning-1	43
WSW45	Speeding up scanning-2	44
WSW46	Monitor of PC ON/OFF state and parallel port kept at High	45

WSW01 (Dial pulse setting)

Selector No.	Function	Setting and Specifications
1 2	Dial pulse generation mode	No. 1 2 0 0 : N 0 1 : N+1 1 0 : 10-N 1 1 : N
3 4	Break time length in pulse dialing	No. 3 4 0 0 : 60 ms 0 1 : 67 ms 1 0 : 40 ms (for 16 PPS) 1 1 : 64 ms (at 106-ms intervals)
5 6	Inter-digit pause	No. 5 6 0 0 : 800 ms 0 1 : 850 ms 1 0 : 950 ms 1 1 : 600 ms
7	Switching between pulse (DP) and tone (PB) dialing, by the function switch	0: Yes 1: No
8	Default dialing mode, pulse (DP) or tone (PB) dialing	0: PB 1: DP

NOTE: In models supporting no pulse (DP) dialing mode (e.g., U.S.A. version), selector 7 takes no effect even if it may be set.

- **Selectors 1 and 2: Dial pulse generation mode**

These selectors set the number of pulses to be generated in pulse dialing.

N: Dialing "N" generates "N" pulses. (Dialing "0" generates 10 pulses.)

N + 1: Dialing "N" generates "N + 1" pulses.

10 - N: Dialing "N" generates "10 - N" pulses.

- **Selectors 3 and 4: Break time length in pulse dialing**

These selectors set the break time length in pulse dialing.

(Example: If "1," "2," and "3" are dialed when N is set by selectors 1 and 2.)

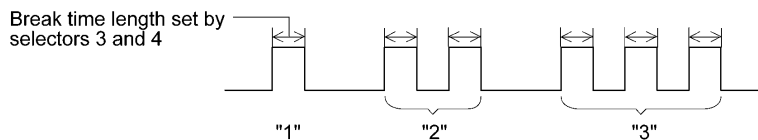

- **Selectors 5 and 6: Inter-digit pause**

These selectors set the inter-digit pause in pulse dialing.

(Example: If "1," "2," and "3" are dialed when N is set by selectors 1 and 2.)

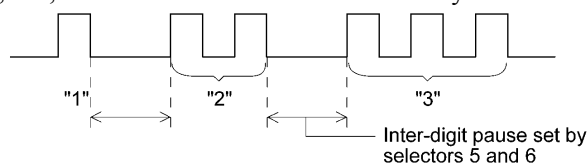

- **Selector 7: Switching between pulse (DP) and tone (PB) dialing, by the function switch**

This selector determines whether or not the dialing mode may be switched between the pulse (DP) and tone (PB) dialing by using the function switch.

- **Selector 8: Default dialing mode, pulse (DP) or tone (PB) dialing**

This selector sets the default dialing mode (pulse dialing or tone dialing) which may be changed by the function switch. If the user switches it with the function switch when selector 7 is set to "0," the setting specified by this selector will also be switched automatically.

WSW02 (Tone signal setting)

Selector No.	Function	Setting and Specifications
1 2	Tone signal transmission time length	No. 1 2 0 0 : 70 ms 0 1 : 80 ms 1 0 : 90 ms 1 1 : 100 ms
3 4	Min. pause in tone dialing	No. 3 4 0 0 : 70 ms 0 1 : 80 ms 1 0 : 90 ms 1 1 : 140 ms
5 8	Attenuator for pseudo ring backtone to the line (selectable in the range of 0-15 dB)	0 : 0 dB 1: 8 dB 0 : 0 dB 1: 4 dB 0 : 0 dB 1: 2 dB 0 : 0 dB 1: 1 dB

- **Selectors 1 through 4: Tone signal transmission time length and Min. pause in tone dialing**

These selectors set the tone signal transmission time length and minimum pause in tone dialing. (Example: If "1," "2," "3," "4," and "5" are dialed.)

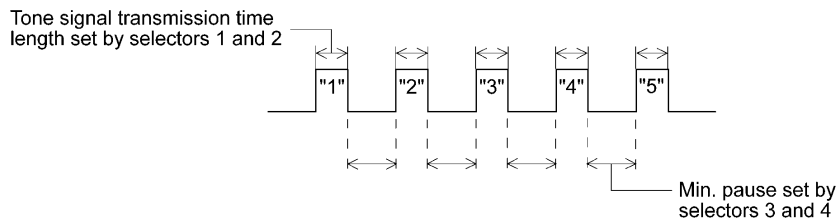

- **Selectors 5 through 8: Attenuator for pseudo ring backtone to the line**

These selectors are used to adjust the sound level of beep generated as a ring backtone in the F/T mode or as a signal during remote control operation or at the start of ICM recording.

Setting two or more selectors to "1" produces addition of attenuation assigned to each selector.

WSW03 (PABX* mode setting)

Selector No.	Function	Setting and Specifications
1	CNG detection when sharing a modular wall socket with a telephone	0: A 1: B
2 4	Min. detection time length of PABX* dial tone, required for starting dialing	No. 2 3 4 0 0 0 : 50 ms 0 0 1 : 210 ms 0 1 0 : 500 ms 0 1 1 : 800 ms 1 0 0 : 900 ms 1 0 1 : 1.5 sec. 1 1 0 : 2.0 sec. 1 1 1 : 2.5 sec.
5	CNG detection when sharing a modular wall socket with a telephone	0: A 1: B
6 7	Dial tone detection in PABX*	No. 6 7 0 0 : No detection (3.5 sec. WAIT) 0 1 : No detection (5 sec. WAIT) 1 0 : No detection (7 sec. WAIT) 1 1 : Detection (Frequency only)
8	Not used.	

* PABX: Private automatic branch exchange

NOTE: Selectors 2 through 4, 6 and 7 are not applicable where no PABX is installed.

• **Selectors 1 and 5: CNG detection when sharing a modular wall socket with a telephone**

These selectors determine whether or not the equipment detects a CNG signal when a line is connected to a telephone sharing a modular wall socket with the equipment. Upon detection of CNG signals by the number of cycles specified by these selectors, the equipment interprets CNG as an effective signal and then starts FAX reception.

Selector No. 1 No. 5		Cycle
0 (A)	0 (A)	0.5 cycle
0 (A)	1 (B)	1.0 cycle
1 (B)	0 (A)	1.5 cycles
1 (B)	1 (B)	2.0 cycles

• **Selectors 2 through 4: Min. detection time length of PABX dial tone, required for starting dialing**

Upon detection of the PABX dial tone for the time length set by these selectors, the equipment starts dialing.

These selectors are effective only when both selectors 6 and 7 are set to "1" (Detection).

- **Selectors 6 and 7: Dial tone detection in PABX**

These selectors activate or deactivate the dial tone detection function which detects a dial tone when a line is connected to the PABX.

Setting both of these selectors to "1" activates the dial tone detection function so that the equipment starts dialing upon detection of a dial tone when a line is connected.

Other setting combinations deactivate the dial tone detection function so that the equipment starts dialing after the specified WAIT (3.5, 5.0, or 7.0 sec.) without detection of a dial tone when a line is connected.

WSW04 (TRANSFER facility setting)

Selector No.	Function	Setting and Specifications
1	Earth function in transfer facility	0: Provided 1: Not provided
2 4	Not used.	
5 6	Earth time length for earth function	No. 5 6 0 0 : 200 ms 0 1 : 300 ms 1 0 : 500 ms 1 1 : 700 ms
7 8	Break time length for flash function	No. 7 8 0 0 : 80 ms 0 1 : 110 ms 1 0 : 250 ms 1 1 : 500 ms

NOTE: Selectors 5 through 8 are not applicable in those countries where no transfer facility is supported.

- **Selector 1: Earth function in transfer facility**

This selector determines whether or not the earth function is added to the transfer setting menu to be accessed by the function switch.

- **Selectors 5 and 6: Earth time length for earth function**

These selectors set the short-circuiting time length of the telephone line (La or Lb) to ground.

This setting is effective only when the earth function is selected for the R key by using the function switch.

- **Selectors 7 and 8: Break time length for flash function**

These selectors set the break time length.

This setting is effective only when the flash function is selected for the R key by using the function switch.

WSW05 (1st dial tone and busy tone detection)

Selector No.	Function	Setting and Specifications
1 3	1st dial tone detection	No. 1 2 3 0 0 0 : 3.5 sec. WAIT 0 0 1 : 7.0 sec. WAIT 0 1 0 : 10.5 sec. WAIT 0 1 1 : 14.0 sec. WAIT 1 0 0 : 17.5 sec. WAIT 1 0 1 : 21.0 sec. WAIT 1 1 0 : 24.5 sec. WAIT 1 1 1 : Detection (Without WAIT)
4	Max. pause time allowable for remote ID code detection	0 : 2 seconds 1: 1 second
5 6	Busy tone detection in automatic sending mode	No. 5 6 0 0 : No detection 0 1 : Detection only after dialing 1 0 : No detection 1 1 : Detection before and after dialing
7	Busy tone detection in automatic receiving mode	0: Yes 1: No
8	Not used.	

NOTE: Selectors 5 through 7 are not applicable in those countries where no busy tone detection is supported.

● **Selectors 1 through 3: 1st dial tone detection**

These selectors activate or deactivate the 1st dial tone detection function which detects the 1st dial tone issued from the PSTN when a line is connected to the PSTN.

Setting all of these selectors to "1" activates the dial tone detection function so that the equipment starts dialing upon detection of a dial tone when a line is connected. For the detecting conditions of the 1st dial tone, refer to WSW07 and WSW08.

Other setting combinations deactivate the dial tone detection function so that the equipment starts dialing after the specified WAIT (3.5, 7.0, 10.5, 14.0, 17.5, 21.0, or 24.5 seconds) without detection of a dial tone when a line is connected to the PSTN.

● **Selector 4: Max. pause time allowable for remote ID code detection**

This selector sets the maximum pause time allowable for detecting the second digit of a remote ID code after detection of the first digit in remote reception.

If selector 4 is set to "0" (2 seconds), for instance, only a remote ID code whose second digit is detected within 2 seconds after detection of the first digit will become effective so as to activate the remote function.

- **Selectors 5 and 6: Busy tone detection in automatic sending mode**

These selectors determine whether or not the equipment automatically disconnects a line upon detection of a busy tone in automatic sending mode.

Setting selector 6 to "0" ignores a busy tone so that the equipment does not disconnect the line.

Setting selectors 5 and 6 to "0" and "1," respectively, makes the equipment detect a busy tone only after dialing and disconnect the line.

Setting both of selectors 5 and 6 to "1" makes the equipment detect a busy tone before and after dialing and then disconnect the line.

- **Selector 7: Busy tone detection in automatic receiving mode**

This selector determines whether or not the equipment automatically disconnects a line upon detection of a busy tone in automatic receiving mode.

WSW06 (Pause key setting and 2nd dial tone detection)

Selector No.	Function	Setting and Specifications
1 3	Pause key setting and 2nd dial tone detection	No. 1 2 3 0 0 0 : No pause 0 0 1 : 3.5 sec. WAIT 0 1 0 : 7 sec. WAIT 0 1 1 : 10.5 sec. WAIT 1 0 0 : 14 sec. WAIT 1 1 0 : 2nd dial tone detection only in pulse dialing (DP) system 1 0 1 : } 2nd dial tone detection 1 1 1 : } both in DP and push-button (PB) dialing system
4 6	Detection of 2nd dial tone	No. 4 5 6 0 0 0 : 50 ms 0 0 1 : 210 ms 0 1 0 : 500 ms 0 1 1 : 800 ms 1 0 0 : 900 ms 1 0 1 : 1.5 sec. 1 1 0 : 2.0 sec. 1 1 1 : 2.5 sec.
7	No. of 2nd dial tone detection times	0: Once 1: Twice
8	2nd dial tone interrupt detecting time	0: 30 ms 1: 50 ms

- **Selectors 1 through 3: Pause key setting and 2nd dial tone detection**

Selectors			
1	2	3	
0	0	0	No WAIT is inserted even if the Pause key is pressed.
0	0	1	If you press the Pause key during dialing, the facsimile equipment will insert WAIT as defined in the above table. If the Pause key is pressed repeatedly, the equipment inserts the specified WAIT multiplied by the number of depressions. It applies also in hook-up dialing.
0	1	0	
0	1	1	
1	0	0	
1	0	1	When these selectors are set to "1, 0, 1": If you press the Pause key during dialing, the equipment will wait for the 2nd dial tone to be sent via the communications line. When these selectors are set to "1, 1, 0" or "1, 1, 1": If you press the Pause key during dialing, the equipment will first wait for the 2nd dial tone to be sent via the communications line. After that, the equipment will insert a WAIT of 3.5 seconds. If no 2nd dial tone is received within the specified time length (set by WSW08), the equipment will disconnect the line if in automatic dialing, or it will start transmitting the dial signal if given after depression of the Pause key in hook-up dialing.
1	1	0	
1	1	1	

- **Selectors 4 through 6: Detection of 2nd dial tone**

Upon detection of the 2nd dial tone for the time length specified by these selectors, the equipment starts dialing.

This setting is effective only when the 2nd dial tone detection function is activated by selectors 1 through 3 (Setting 101, 110, or 111).

This function does not apply in those countries where no dial tone detection function is supported.

- **Selector 7: No. of 2nd dial tone detection times**

This selector sets the number of dial tone detection times required for starting dialing.

- **Selector 8: 2nd dial tone interrupt detecting time**

This selector sets the allowable time length of an interrupt which should not be interpreted as an interrupt in the 2nd tone dialing.

WSW07 (Dial tone setting 1)

Selector No.	Function	Setting and Specifications
1 2	Frequency band range	No. 1 2 0 0 : Narrows by 10 Hz 0 1 : Initial value 1 X : Widens by 10 Hz
3	Line current detection	0: No 1: Yes
4 6	2nd dial tone detection level (Z = 600 Ω)	No. 4 5 6 0 0 0 : -21 dBm 0 0 1 : -24 dBm 0 1 0 : -27 dBm 0 1 1 : -30 dBm 1 0 0 : -33 dBm 1 0 1 : -36 dBm 1 1 0 : -39 dBm 1 1 1 : -42 dBm
7	1st dial tone interrupt detecting time	0: 30 ms 1: 50 ms
8	Not used.	

NOTE: Selectors 1 through 7 are not applicable in those countries where no dial tone or line current detection is supported, e.g., U.S.A.

- **Selectors 1 and 2: Frequency band range**

These selectors set the frequency band for the 1st dial tone and the busy tone (before dialing) to be detected.

This setting is effective only when selectors 1 through 3 of WSW05 are set to "1,1,1."

- **Selector 3: Line current detection**

This selector determines whether or not the equipment should detect a line current before starting dialing.

- **Selectors 4 through 6: 2nd dial tone detection level**

These selectors set the detection level of the 2nd dial tone.

- **Selector 7: 1st dial tone interrupt detecting time**

This selector sets the allowable time length of an interrupt which should not be interpreted as an interrupt in the 1st dial tone dialing.

WSW08 (Dial tone setting 2)

Selector No.	Function	Setting and Specifications
1 3	1st dial tone detection time length	No. 1 2 3 0 0 0 : 50 ms 0 0 1 : 210 ms 0 1 0 : 500 ms 0 1 1 : 800 ms 1 0 0 : 900 ms 1 0 1 : 1.5 sec. 1 1 0 : 2.0 sec. 1 1 1 : 2.5 sec.
4 5	Time-out length for 1st and 2nd dial tone detection	No. 4 5 0 0 : 10 sec. 0 1 : 20 sec. 1 0 : 15 sec. 1 1 : 30 sec.
6 8	Detection level of 1st dial tone and busy tone before dialing	No. 6 7 8 0 0 0 : -21 dBm 0 0 1 : -24 dBm 0 1 0 : -27 dBm 0 1 1 : -30 dBm 1 0 0 : -33 dBm 1 0 1 : -36 dBm 1 1 0 : -39 dBm 1 1 1 : -42 dBm

NOTE: The WSW08 is not applicable in those countries where no dial tone detection is supported, e.g., U.S.A.

- **Selectors 1 through 3: 1st dial tone detection time length**

Upon detection of the 1st dial tone for the time length set by these selectors, the equipment starts dialing.

This setting is effective only when selectors 1 through 3 of WSW05 are set to "1,1,1."

- **Selectors 4 and 5: Time-out length for 1st and 2nd dial tone detection**

These selectors set the time-out length for the 1st and 2nd dial tone detection so that the equipment waits dial tone input for the specified time length and disconnects itself from the line when no dial tone is inputted.

WSW09 (Protocol definition 1)

Selector No.	Function	Setting and Specifications	
1	Frame length selection	0: 256 octets 1: 64 octets	
2	Use of non-standard commands	0: Allowed 1: Prohibited	
3 4	No. of retries	No. 3 4 0 0 : 4 times 0 1 : 3 times 1 0 : 2 times 1 1 : 1 time	
5		T5 timer	0: 300 sec. 1: 60 sec.
6		T1 timer	0: 35 sec. 1: 40 sec.
7 8		Elapsed time for time-out control for no response from the called station in automatic sending mode	No. 7 8 0 0 : 60 sec. (55 sec. for US and Canada) 0 1 : 140 sec. 1 0 : 90 sec. 1 1 : 35 sec.

NOTE: Selectors 1 through 6 are not applicable in those models which do not support ECM.

- **Selector 1: Frame length selection**

Usually a single frame consists of 256 octets (1 octet = 8 bits). For communications lines with higher bit error rate, however, set selector 1 to "1" so that the facsimile equipment can divide a message into 64-octet frames.

Remarks: The error correction mode (ECM) is a facsimile transmission manner in which the equipment divides a message into frames for transmission so that if any data error occurs on the transmission line, the equipment retransmits only those frames containing the error data.

- **Selector 2: Use of non-standard commands**

If this selector is set to "0," the equipment may use non-standard commands (the machine's native-mode commands, e.g., NSF, NSC, and NSS) for communications. If it is set to "1," the equipment will use standard commands only.

- **Selectors 3 and 4: No. of retries**

These selectors set the number of retries in each specified modem transmission speed.

- **Selector 5: T5 timer**

This selector sets the time length for the T5 timer.

- **Selector 6: T1 timer**

This selector sets the time length for the T1 timer.

- **Selectors 7 and 8: Elapsed time for time-out control**

If the equipment receives no response (no G3 command) from the called terminal in automatic sending during the time set by these selectors, it disconnects the line.

WSW10 (Protocol definition 2)

Selector No.	Function	Setting and Specifications
1	Switching of DPS, following the CML ON/OFF	0: No 1: Yes
2	Time length from transmission of the last dial digit to CML ON	0: 100 ms 1: 50 ms
3	Time length from CML ON to CNG transmission	0: 2 sec. 1: 4 sec.
4	Time length from CML ON to CED transmission (except for facsimile-to-telephone switching)	0: 0.5 sec. 1: 2 sec.
5 6	No. of training retries	No. 5 6 0 0 : 1 time 0 1 : 2 times 1 0 : 3 times 1 1 : 4 times
7	Encoding system (Compression)	MR 0: Allowed 1: Not allowed
8		MMR 0: Allowed 1: Not allowed

- **Selector 1: Switching of DPS, following the CML ON/OFF**
Setting this selector to "1" automatically switches DPS following the CML ON/OFF operation.
- **Selector 2: Time length from transmission of the last dial digit to CML ON**
This selector sets the time length from when the equipment transmits the last dial digit until the CML relay comes on.
- **Selector 3: Time length from CML ON to CNG transmission**
This selector sets the time length until the equipment transmits a CNG after it turns on the CML relay.
- **Selector 4: Time length from CML ON to CED transmission**
This selector sets the time length until the equipment transmits a CED after it turns on the CML relay. This setting does not apply to switching between facsimile and telephone.
- **Selectors 5 and 6: No. of training retries**
These selectors set the number of training retries to be repeated before automatic fallback.
- **Selectors 7 and 8: Encoding system (Compression)**
This selector determines whether or not use of the MR/MMR coding system will be allowed.

WSW11 (Busy tone setting)

Selector No.	Function	Setting and Specifications
1 2	Frequency band range	No. 1 2 0 0 : Narrows by 10 Hz 0 1 : Initial value 1 x : Widens by 10 Hz
3	Not used.	
4	ON/OFF time length ranges (More than one setting allowed)	1: 400-600/400-600 ms
5		1: 175-440/175-440 ms
6		1: 100-1000/17-660 ms
7		1: 110-410/320-550 ms
8		1: 100-660/100-660 ms

NOTE: WSW11 is not applicable in those countries where no busy tone detection is supported.

NOTE: The setting of WSW11 is effective only when selectors 5 and 6 of WSW05 are set to "0, 1" or "1, 1" (Busy tone detection).

- **Selectors 1 and 2: Frequency band range**

These selectors set the frequency band for busy tone to be detected.

- **Selectors 4 through 8: ON/OFF time length ranges**

These selectors set the ON and OFF time length ranges for busy tone to be detected. If more than one selector is set to "1," the ranges become wider. For example, if selectors 4 and 5 are set to "1," the ON and OFF time length ranges are from 175 to 600 ms.

WSW12 (Signal detection condition setting)

Selector No.	Function	Setting and Specifications
1 2	Min. OFF time length of calling signal (Ci)	No. 1 2 0 0 : 1500 ms 0 1 : 500 ms 1 0 : 700 ms 1 1 : 900 ms
3 4	Max. OFF time length of calling signal (Ci)	No. 3 4 0 0 : 6 sec. 0 1 : 7 sec. 1 0 : 9 sec. 1 1 : 11 sec.
5 6	Detecting time setting	No. 5 6 0 0 : 800 ms 0 1 : 200 ms 1 0 : 250 ms 1 1 : 150 ms
7	Delay	0: Yes 1: No
8	Not used.	

- **Selectors 1 through 4: Min. and max. OFF time length of calling signal (Ci)**

If the equipment detects the OFF state of calling signal (Ci) for a time length which is greater than the value set by selectors 1 and 2 and less than the value set by selectors 3 and 4, then it interprets the Ci signal as OFF.

- **Selectors 5 and 6: Detecting time setting**

These selectors set the time length required to make the equipment acknowledge itself to be called. That is, if the equipment continuously detects calling signals with the frequency set by selectors 1 through 4 of WSW14 during the time length set by these selectors 5 and 6, it acknowledges the call.

- **Selector 7: Delay**

Setting this selector to "0" allows the equipment to insert a 900 ms WAIT after acknowledgment of the call until the equipment turns on the CML relay to start receiving operation.

WSW13 (Modem setting)

Selector No.	Function	Setting and Specifications
1 2	Cable equalizer	No. 1 2 0 0 : 0 km 0 1 : 1.8 km 1 0 : 3.6 km 1 1 : 5.6 km
3 4	Reception level	No. 3 4 0 0 : -43 dBm 0 1 : -47 dBm 1 0 : -49 dBm 1 1 : -51 dBm
5 8	Modem attenuator	0: 0 dB 1: 8 dB 0: 0 dB 1: 4 dB 0: 0 dB 1: 2 dB 0: 0 dB 1: 1 dB

The modem should be adjusted according to the user's line conditions.

- **Selectors 1 and 2: Cable equalizer**

These selectors are used to improve the pass-band characteristics of analogue signals on a line. (Attenuation in the high-band frequency is greater than in the low-band frequency.)

Set these selectors according to the distance from the telephone switchboard to the facsimile equipment.

- **Selectors 3 and 4: Reception level**

These selectors set the optimum receive signal level.

- **Selectors 5 through 8: Modem attenuator**

These selectors are used to adjust the transmitting level of the modem when the reception level at the remote station is improper due to line loss. This function applies to G3 protocol signals.

Setting two or more selectors to "1" produces addition of attenuation assigned to each selector.

This setting will be limited if selector 8 of WSW23 is set to "0."

WSW14 (AUTO ANS facility setting)

Selector No.	Function	Setting and Specifications
1 2	Frequency band selection (Lower limit)	No. 1 2 0 0 : 13 Hz 0 1 : 15 Hz 1 0 : 23 Hz 1 1 : 20 Hz
3 4	Frequency band selection (Upper limit)	No. 3 4 0 0 : 30 Hz 0 1 : 55 Hz 1 0 : 70 Hz 1 1 : 200 Hz
5 8	No. of rings in AUTO ANS mode	No. 5 6 7 8 0 0 0 0 : Fixed to once 0 0 0 1 : Fixed to 2 times 0 0 1 0 : Fixed to 3 times 0 0 1 1 : Fixed to 4 times 0 1 0 0 : 1 to 2 times 0 1 0 1 : 1 to 3 times 0 1 1 0 : 1 to 4 times 0 1 1 1 : 1 to 5 times 1 0 0 0 : 2 to 3 times 1 0 0 1 : 2 to 4 times 1 0 1 0 : 2 to 5 times 1 0 1 1 : 2 to 6 times 1 1 0 0 : 1 to 10 times 1 1 0 1 : 2 to 10 times 1 1 1 0 : 3 to 5 times 1 1 1 1 : 4 to 10 times

- **Selectors 1 through 4: Frequency band selection**

These selectors are used to select the frequency band of calling signals for activating the AUTO ANS facility.

In the French versions, if the user sets the PBX to OFF from the control panel, the setting made by selectors 1 and 2 will take no effect and the frequency's lower limit will be fixed to 32 Hz. (Even if the setting made by these selectors does not apply, it will be printed on the configuration list.)

- **Selectors 5 through 8: No. of rings in AUTO ANS mode**

These selectors set the number of rings to initiate the AUTO ANS facility.

WSW15 (REDIAL facility setting)

Selector No.	Function	Setting and Specifications
1 2	Selection of redial interval	No. 1 2 0 0 : 5 minutes 0 1 : 1 minute 1 0 : 2 minutes 1 1 : 3 minutes
3 6	No. of redialings	No. 3 4 5 6 0 0 0 0 : 16 times 0 0 0 1 : 1 times 0 0 1 0 : 2 times 0 0 1 1 : 3 times 1 1 1 1 : 15 times
7	Redialing for no response sent from the called terminal	0: Redialing 1: No redialing
8	Not used.	

NOTE: Selector 7 is not applicable in those countries where no busy tone detection is supported.

- **Selectors 1 through 6: Selection of redial interval and No. of redialings**

The equipment redials by the number of times set by selectors 3 through 6 at intervals set by selectors 1 and 2.

This setting is effective only when selector 7 is set to "0."

- **Selectors 7: Redialing for no response sent from the called terminal**

This selector determines whether or not the equipment redials if no G3 command response comes from the called station after dialing within the time length set by selectors 7 and 8 of WSW09.

WSW16 (Function setting 1)

Selector No.	Function	Setting and Specifications
1	Not used.	
2	CCITT superfine recommendation	0: OFF 1: ON
3 6	Not used.	
7	Max. document length limitation	0: 400 cm 1: 90 cm
8	Stop key pressed during reception	0: Not functional 1: Functional

- **Selector 2: CCITT superfine recommendation**

If this selector is set to "1," the equipment communicates in CCITT recommended superfine mode (15.4 lines/mm). If it is set to "0," it communicates in native superfine mode.

- **Selector 7: Max. document length limitation**

This selector is used to select the maximum length of a document to be sent.

- **Selector 8: Stop key pressed during reception**

If this selector is set to "1," pressing the **Stop** key can stop the current receiving operation. The received data will be lost.

WSW17 (Function setting 2)

Selector No.	Function	Setting and Specifications
1 2	Off-hook alarm	No. 1 2 0 0 : No alarm 0 1 : Always valid 1 X : Valid except when 'call reservation' is selected.
3 4	Not used.	
5	Calendar clock type	0: U.S.A. type 1: European type
6	Not used.	
7	Non-ring reception	0: OFF 1: ON
8	Not used.	

- **Selectors 1 and 2: Off-hook alarm**

These selectors activate or deactivate the alarm function which sounds an alarm when the communication is completed with the handset being off the hook.

- **Selector 5: Calendar clock type**

If this selector is set to "0" (USA), the MM/DD/YY hh:mm format applies; if it is set to "1" (Europe), the DD/MM/YY hh:mm format applies: DD is the day, MM is the month, YY is the last two digits of the year, hh is the hour, and mm is the minute.

- **Selector 7: Non-ring reception**

Setting this selector to "1" makes the equipment receive calls without ringer sound if the ring delay is set to 0.

WSW18 (Function setting 3)

Selector No.	Function	Setting and Specifications
1	Not used.	
2 3	Detection enabled time for CNG and no tone	No. 2 3 0 0 : 40 sec. 0 1 : 0 sec. (No detection) 1 0 : 5 sec. 1 1 : 80 sec.
4 5	Not used.	
6	Registration of station ID	0: Permitted 1: Prohibited
7 8	Tone sound monitoring	No. 7 8 0 X : No monitoring 1 0 : Up to phase B at the calling station only 1 1 : All transmission phases both at the calling and called stations

- **Selectors 2 and 3: Detection enabled time for CNG and no tone**

After the line is connected via the external telephone or by picking up the handset of the facsimile equipment, the equipment can detect a CNG signal or no tone for the time length specified by these selectors. The setting specified by these selectors becomes effective only when selector 8 of WSW20 is set to "1."

- **Selectors 7 and 8: Tone sound monitoring**

These selectors set monitoring specifications of the tone sound inputted from the line.

WSW19 (Transmission speed setting in V. 17 mode)

Selector No.	Function	Setting and Specifications
1 3	First transmission speed choice for fallback	No. 1 2 3 No. 4 5 6 0 0 0 : 2,400 bps 0 0 1 : 4,800 bps 0 1 0 : 7,200 bps 0 1 1 : 9,600 bps 1 0 0 : 12,000 bps 1 0 1 : } 1 1 0 : } 14,400 bps 1 1 1 : }
4 6	Last transmission speed choice for fallback	
7	V. 34 mode	0: Permitted 1: Prohibited
8	V. 17 mode	0: Permitted 1: Prohibited

NOTE: For the transmission speed setting in V.34 mode, refer to WSW39.

- **Selectors 1 through 6: First and last choices of transmission speed for fallback**

These selectors are used to set the modem speed range. With the first transmission speed choice specified by selectors 1 through 3, the equipment attempts to establish the transmission link via the modem. If the establishment fails, the equipment automatically steps down to the next highest speed and attempts to establish the transmission link again. The equipment repeats this sequence while stepping down the transmission speed to the last choice specified by selectors 4 through 6.

If the modem always falls back to a low transmission speed (e.g., 4,800 bps), set the first transmission speed choice to the lower one (e.g., modify it from 12,000 bps to 7,200 bps) in order to deactivate the high-speed modem function and reduce the training time for shorter transmission time.

Generally, to save the transmission time, set the last transmission speed choice to a higher one.

- **Selector 7: V. 34 mode**

This selector determines whether or not the equipment communicates with the remote station in the V. 34 mode when that station supports the V. 34 mode.

WSW20 (Overseas communications mode setting)

Selector No.	Function	Setting and Specifications
1	EP* tone prefix	0: OFF 1: ON
2	Overseas communications mode (Reception)	0: 2100 Hz 1: 1100 Hz
3	Overseas communications mode (Transmission)	0: OFF 1: Ignores DIS once.
4 5	Min. time length from reception of CFR to start of transmission of video signals	No. 4 5 0 0 : 100 ms 0 1 : 200 ms 1 0 : 300 ms 1 1 : 400 ms
6 7	Chattering noise elimination at detection of CNG	No. 6 7 0 0 : Yes (When CNG goes either ON or OFF) 0 1 : Yes (Only when CNG goes OFF) 1 0 : No 1 1 : No
8	CNG detection on/off	0: OFF 1: ON

* EP: Echo protection

- **Selector 1: EP tone prefix**

Setting this selector to "1" makes the equipment transmit a 1700 Hz echo protection (EP) tone immediately preceding training in V.29 modulation system to prevent omission of training signals.

Prefixing an EP tone is effective when the equipment fails to transmit at the V.29 modem speed and always has to fall back to 4800 bps transmission.

- **Selectors 2 and 3: Overseas communications mode**

These selectors should be used if the facsimile equipment malfunctions in overseas communications. According to the communications error state, select the signal specifications.

Setting selector 2 to "1" allows the equipment to use 1100 Hz CED signal instead of 2100 Hz in receiving operation. This prevents malfunctions resulting from echoes, since the 1100 Hz signal does not disable the echo suppressor (ES) while the 2100 Hz signal does.

Setting selector 3 to "1" allows the equipment to ignore a DIS signal sent from the called station once in sending operation. This operation suppresses echoes since the first DIS signal immediately follows a 2100 Hz CED (which disables the ES) so that it is likely to be affected by echoes in the disabled ES state. However, such a disabled ES state will be removed soon so that the second and the following DIS signals are not susceptible to data distortion due to echoes. Note that some models when called may cause error by receiving a self-outputted DIS.

- **Selectors 8: CNG detection on/off**

If this selector is set to "1," the equipment detects a CNG signal according to the condition preset by selectors 2 and 3 of WSW18 after a line is connected. If it is set to "0," the equipment detects a CNG signal as long as the line is connected.

WSW21 (TAD setting 1)

Selector No.	Function	Setting and Specifications
1 7	Not used.	
8	Erasure of message stored in the memory after the message transfer	0: Yes 1: No

- **Selector 8: Erasure of message**

Setting this selector to "0" will erase the message recorded in the memory after the document retrieval feature transfers the message.

WSW22 (ECM setting)

Selector No.	Function	Setting and Specifications
1	ECM* in sending	0: ON 1: OFF
2	ECM* in receiving	0: ON 1: OFF
3	Call Waiting Caller ID	0: ON 1: OFF
4	Not used.	
5 8	Acceptable TCF bit error rate (%) (Only at 4800 bps)	0: 0% 1: 8% 0: 0% 1: 4% 0: 0% 1: 2% 0: 0% 1: 1%

* ECM: Error correction mode

NOTE: Selector 3 is applicable to the American version only, but not applicable to those models equipped with high-speed modem.

NOTE: Selectors 5 through 8 are applicable to the Asian version only.

- **Selector 3: Call Waiting Caller ID**

Setting this selector to "0" allows the user to decide whether or not to interrupt the current call when a new call comes in. If Call Waiting Caller ID service is available in the area and the user subscribes to it, he/she can see information about his/her incoming call.

- **Selectors 5 through 8: Acceptable TCF bit error rate (%)**

Setting two or more selectors to "1" produces addition of percent assigned to each selector. If you set selectors 7 and 8 to "1," the acceptable TCF bit error rate will be 3%.

WSW23 (Communications setting)

Selector No.	Function	Setting and Specifications
1	Starting point of training check (TCF)	0: From the head of a series of zeros 1: From any arbitrary point
2 3	Allowable training error rate	No. 2 3 0 0 : 0% 0 1 : 0.5% 1 0 : 1% 1 1 : 2%
4 5		No. 4 5 0 0 : 16% 0 1 : 14% 1 0 : 10% 1 1 : 8%
6 7	Not used.	
8	Limitation of attenuation level	0: Yes 1: No

NOTE: Selector 8 is not applicable to the French versions.

- **Selector 1: Starting point of training check (TCF)**

At the training phase of receiving operation, the called station detects for 1.0 second a training check (TCF) command, a series of zeros which is sent from the calling station for 1.5 seconds to verify training and give the first indication of the acceptability of the line.

This selector sets the starting point from which the called station should start counting those zeros. If this selector is set to "0," the called station starts counting zeros 100 ms after the head of a series of zeros is detected.

If it is set to "1," the called station starts counting zeros upon detection of 10-ms successive zeros 50 ms after the head of a series of zeros is detected. In this case, if the detection of 10-ms successive zeros is too late, the data counting period will become less than 1.0 second, making the called station judge the line condition unacceptable.

- **Selectors 2 and 3: Allowable training error rate**

The called station checks a series of zeros gathered in training (as described in Selector 1) according to the allowable training error rate set by these selectors. If the called station judges the line condition to be accepted, it responds with CFR; if not, it responds with FTT.

- **Selectors 4 and 5: Decoding error rate for transmission of RTN**

The facsimile equipment checks the actual decoding errors and then transmits an RTN according to the decoding error rate (Number of lines containing an error per page ÷ Total number of lines per page) set by these selectors.

- **Selector 8: Limitation of attenuation level**

Setting this selector to "0" limits the transmitting level of the modem to 10 dB.

This setting has priority over the settings selected by WSW02 (selectors 5 through 8) and WSW13 (selectors 5 through 8).

WSW24 (TAD setting 2)

Selector No.	Function	Setting and Specifications
1 2	Not used.	
3 4	Time length from CML ON to start of pseudo ring backtone transmission	No. 3 4 0 0 : 4 sec. 0 1 : 3 sec. 1 0 : 2 sec. 1 1 : 1 sec.
5 8	Attenuator for playback of ICM/OGM to the line (Selectable from the range of 0-15 dB)	0: 0 dB 1: 8 dB 0: 0 dB 1: 4 dB 0: 0 dB 1: 2 dB 0: 0 dB 1: 1 dB

- **Selectors 3 and 4: Time length from CML ON to start of pseudo ring backtone transmission**

These selectors set the length of time from CML-ON up to the start of pseudo ring backtone transmission.

In those versions which have an OGM facility, the settings made by these selectors also apply to the length of time from CML-ON up to the start of OGM transmission.

- **Selectors 5 through 8: Attenuator for playback of ICM/OGM to the line**

Setting two or more selectors to "1" produces addition of attenuation assigned to each selector.

This setting will not be limited by selector 8 of WSW23.

WSW25 (TAD setting 3)

Selector No.	Function	Setting and Specifications
1 2	Delay time for starting detection of voice signal	No. 1 2 0 0 : 0 sec. 0 1 : 8 sec. 1 0 : 16 sec. 1 1 : 24 sec.
3 4	Detection level for no voice signal	No. 3 4 0 0 : -43 dB (A) 0 1 : -46 dB (B) 1 0 : -49 dB (C) 1 1 : -51 dB (D)
5 7	Pause between paging number and PIN	No. 5 6 7 0 0 0 : 2 sec. 0 0 1 : 4 sec. 0 1 0 : 6 sec. 0 1 1 : 8 sec. 1 0 0 : 10 sec. 1 0 1 : 12 sec. 1 1 0 : 14 sec. 1 1 1 : 16 sec.
8	Not used.	

NOTE: Selectors 1 through 4 are not applicable to the U.S.A. versions.

NOTE: Selectors 5 through 7 are applicable to those models equipped with a built-in TAD.

● **Selectors 1 and 2: Delay time for starting detection of voice signal**

These selectors take effect only in TAD mode (when the external TAD is connected to the equipment). The equipment delays starting detection of the voice signal by the time length specified by these selectors.

The total length of the delay time specified by these selectors and the maximum waiting time specified by WSW21 (selectors 1 through 5) should not exceed 40 seconds.

● **Selectors 3 and 4: Detection level for no voice signal**

These selectors set the detection level for no voice signal in the TAD mode (when the external TAD is connected to the equipment).

● **Selectors 5 through 7: Pause between paging number and PIN**

These selectors set the pause time between a telephone number being paged and PIN (private identification number) for the paging feature.

WSW26 (Function setting 4)

Selector No.	Function	Setting and Specifications
1 2	Not used.	
3	Dialing during document reading into the temporary memory in in-memory message transmission	0: Disabled 1: Enabled
4 5	No. of CNG cycles to be detected (when the line is connected via the external telephone except in the external TAD mode or via the built-in telephone of the facsimile equipment)	No. 4 5 0 0 : 0.5 (A) 0 1 : 1 (B) 1 0 : 1.5 (C) 1 1 : 2 (D)
6 8	Not used.	

- **Selector 3: Dialing during document reading into the temporary memory in in-memory message transmission**

If this selector is set to "0," the equipment waits for document reading into the memory to complete and then starts dialing. This enables the equipment to list the total number of pages in the header of the facsimile message.

- **Selectors 4 and 5: No. of CNG cycles to be detected**

The equipment interprets a CNG as an effective signal if it detects a CNG signal by the number of cycles specified by these selectors in any of the following cases:

- when the line is connected via the external telephone except in the external TAD mode.
- when the line is connected via the built-in telephone of the facsimile equipment.

WSW27 (Function setting 5)

Selector No.	Function	Setting and Specifications
1	Definition of programmable key	0: TEL key 1: TEL/POLLING key
2	Ringer OFF setting	0: Yes 1: No
3	Not used.	
4	Detection of distinctive ringing pattern	0: Yes 1: No
5 7	Not used.	
8	Toner save mode	0: Yes 1: No

NOTE: Selector 1 takes effect only in models/versions having a TEL key.

NOTE: Selector 4 is applicable only to the U.S.A. version.

- **Selector 1: Definition of programmable key**

This selector defines a programmable key as a TEL key or TEL/POLLING key.

Setting this selector to "1" allows the programmable key to function as either a TEL or POLLING key if pressed when the handset is off or on the hook, respectively.

- **Selector 2: Ringer OFF setting**

This selector determines whether or not the ringer can be set to OFF.

- **Selector 4: Detection of distinctive ringing pattern**

If this selector is set to "1," the equipment detects only the number of rings; if it is set to "0," the equipment detects the number of rings and the ringing time length to compare the detected ringing pattern with the registered distinctive one.

WSW28 (Function setting 6)

Selector No.	Function	Setting and Specifications
1 3	Transmission level of DTMF high-band frequency signal	No. 1 2 3 0 0 0 : 0 dB 0 0 1 : +1 dB 0 1 0 : +2 dB 0 1 1 : +3 dB 1 0 0 : 0 dB 1 0 1 : -1 dB 1 1 0 : -2 dB 1 1 1 : -3 dB
4 6	Transmission level of DTMF low-band frequency signal	No. 4 5 6 0 0 0 : 0 dB 0 0 1 : +1 dB 0 1 0 : +2 dB 0 1 1 : +3 dB 1 0 0 : 0 dB 1 0 1 : -1 dB 1 1 0 : -2 dB 1 1 1 : -3 dB
7 8	Not used.	

- **Selectors 1 through 6: Transmission level of DTMF high-/low-band frequency signal**

These selectors are intended for the manufacturer who tests the equipment for the Standard. Never access them.

WSW29 (Function setting 7)

Selector No.	Function	Setting and Specifications
1 6	Not used.	
7	Impedance switching control in pulse dialing	0: OFF 1: ON
8	Beep when the memory area for the activity report becomes full	0: No 1: Yes

NOTE: Selectors 7 and 8 are applicable to the European version only.

- **Selector 8: Beep when the memory area for the activity report becomes full**

If this selector is set to "1," the equipment will beep when the memory area for the activity report becomes full (as well as displaying a message on the LCD, prompting the output of the activity report).

WSW30 (Function setting 8)

Selector No.	Function	Setting and Specifications
1 3	Not used.	
4	Duty cycle control of pulsed current for the heat-fixing unit	0: OFF 1: ON
5 8	Not used.	

NOTE: Selector 4 is applicable to the European version only.

- **Selector 4: Duty cycle control of pulsed current for the heat-fixing unit**

Setting this selector to "1" activates the duty cycle control that suppresses the rush current. The duty cycle is 10-ms ON and 20-ms OFF.

However, the duty cycle control may emit switching noise to the AC line. Depending upon the codes and regulations in the country, this selector should be set to "0."

WSW31 (Function setting 9)

Selector No.	Function	Setting and Specifications
1	Not used.	
2	Default reduction rate for failure of automatic reduction during recording	0: 100% 1: Reduction rate specified according to the current paper size
3 4	Not used.	
5	Minimum short-OFF duration in distinctive ringing	0: 130 ms 1: 90 ms
6 7	Not used.	
8	"CHANGE DRUM SOON" message	0: Yes 1: No

- **Selector 2: Default reduction rate for failure of automatic reduction during recording**

This selector sets the default reduction rate to be applied if the automatic reduction function fails to record one-page data sent from the calling station in a single page of the current recording paper.

If it is set to "0," the equipment records one-page data at full size (100%) without reduction; if it is set to "1," the equipment records it at the size specified according to the current paper size.

- **Selector 5: Minimum short-OFF duration in distinctive ringing**

The ringer pattern consists of short and long rings, e.g., short-short-long rings. This selector sets the minimum OFF duration following a short ring in order to avoid missing ringer tones in distinctive ringing.

If this selector is set to "1," when the short-OFF duration is a minimum of 90 ms long, then the equipment will interpret the short-OFF as OFF.

- **Selector 8: "CHANGE DRUM SOON" message**

This selector determines whether or not the "CHANGE DRUM SOON" message should appear on the LCD when the service life of the laser-sensitive drum in the laser unit will expire soon.

WSW32 (Function setting 10)

Selector No.	Function	Setting and Specifications
1 4	Not used.	
5 6	Default resolution	No. 5 6 0 0 : Standard 0 1 : Fine 1 0 : Super fine 1 1 : Photo
7 8	Default contrast	No. 7 8 0 X : Automatic 1 0 : Super light 1 1 : Super dark

- **Selectors 5 and 6: Default resolution**

These selectors set the default resolution which applies when the equipment is powered up or completes a transaction.

- **Selectors 7 and 8: Default contrast**

These selectors set the default contrast which applies when the equipment is powered up or completes a transaction.

WSW33 (Function setting 11)

Selector No.	Function	Setting and Specifications
1 5	Not used.	
6	Report output of polled transmission requests	0: Yes 1: No
7 8	Not used.	

NOTE: Selector 6 is not applicable to American versions.

WSW34 (Function setting 12)

Selector No.	Function	Setting and Specifications
1 3	Not used.	
4 5	No. of CNG cycles to be detected (when the line is connected via the facsimile equipment in the F/T mode or via the external telephone in the external TAD mode)	No. 4 5 0 0 : 0.5 (A) 0 1 : 1 (B) 1 0 : 1.5 (C) 1 1 : 2 (D)
6 7	Number of DTMF tone signals for inhibiting the detection of CNG during external TAD operation	No. 6 7 0 0 : 3 0 1 : 2 1 0 : 1 1 1 : OFF
8	CNG detection when the external telephone is connected with a line in TAD mode	0: Only when the equipment detects itself being called 1: Always

NOTE: Selectors 4 and 5 are not applicable to the American version.

- **Selectors 4 and 5: No. of CNG cycles to be detected**

The equipment interprets a CNG as an effective signal if it detects a CNG signal by the number of cycles specified by these selectors when the line is connected via the facsimile equipment in the F/T mode or via the external telephone in the external TAD mode.

- **Selectors 6 and 7: Number of DTMF tone signals for inhibiting the detection of CNG during external TAD operation**

If the equipment receives this specified number of DTMF tone signals during external TAD operation, then it will not detect CNG afterwards.

If these selectors are set to "1, 1," the CNG detection will not be inhibited.

- **Selector 8: CNG detection when the external telephone is connected with a line in TAD mode**

If this selector is set to "0," the equipment will detect a CNG signal only when it detects itself being called. If the external telephone is connected with a line before the equipment detects itself being called, the equipment will no longer detect a CNG signal.

If this selector is set to "1," the equipment will detect a CNG signal every time the external telephone is connected with a line, even without detecting itself being called.

WSW35 (Function setting 13)

Selector No.	Function	Setting and Specifications
1 8	Not used.	

WSW36 (Function setting 14)

Selector No.	Function	Setting and Specifications
1	ECP* mode	0: ON 1: OFF
2	Recovery from inactive PC interface	0: Disabled 1: Enabled
3	PC power-off recognition time	0: Normal 1: Long
4	Not used.	
5	Escape from phase C	0: Yes 1: No
6 8	Lower limit of frequency to be ignored after detection of calling signals (Ci)	No. 6 7 8 0 0 0 : 0 (Not ignored) 0 0 1 : 4 (448 Hz) 0 1 0 : 8 (244 Hz) 0 1 1 : 12 (162 Hz) 1 0 0 : 16 (122 Hz) 1 0 1 : 20 (97 Hz) 1 1 0 : 24 (81 Hz) 1 1 1 : 28 (69 Hz)

*ECP (Enhanced Capabilities Port)

- **Selector 1: ECP mode**

The ECP mode enhances the normal bidirectional communications between the facsimile equipment and the connected PC for higher transmission speed.

- **Selector 2: Recovery from inactive PC interface**

If the facsimile equipment recognizes via the STROBE signal line that the connected PC is powered off, then it will turn the PC interface output Low to protect the PC from hazards that could be caused by weak electric current accidentally flown from the equipment.

This selector determines whether the equipment should recover from the inactive PC interface to normal interfacing state upon receipt of data from the PC.

- **Selector 3: PC power-off recognition time**

This selector sets the time length from when the equipment detects the PC powered off until it recognizes the detected state as power-off.

If selector 2 is set to "0," it is recommended that selector 3 be set to "1": otherwise, the equipment may mistakenly detect PC powered off.

- **Selector 5: Escape from phase C**

This selector determines whether or not the equipment will escape from phase C when it detects an RTC (Return to Control) in non-ECM mode or an RCP (Return to Control Partial page) in ECM mode.

- **Selectors 6 through 8: Lower limit of frequency to be ignored after detection of calling signals (Ci)**

At the start of reception, if the equipment detects the frequency of calling signals (Ci) specified by selectors 1 through 4 of WSW14, it will start the ringer sounding. When doing so, the equipment may fail to detect the calling signals normally due to noises superimposed at the time of reception. To prevent it, use selectors 6 through 8 of WSW36.

If the equipment detects higher frequencies than the lower limit specified by these selectors, then it will regard them as noise and interpret that detecting state as being normal, allowing the ringer to keep sounding (until the equipment starts automatic reception of FAX data if in the FAX mode or enters the TAD mode if set in the TEL mode, according to the preset number of ringers).

WSW37 (Function setting 15)

Selector No.	Function	Setting and Specifications
1	Printout of the stored image data of an unsent document onto the error report	0: No 1: Yes
2	Erasure of the stored image data of an unsent document at the time of the subsequent in-memory message transmission	0: No 1: Yes
3 8	Not used.	

- **Selector 1: Printout of the stored image data of an unsent document onto an error report**

This selector determines whether or not the 1st-page image data of a document will be printed out onto the error report if the document image data stored in the temporary memory cannot be transmitted normally.

- **Selector 2: Erasure of the stored image data of an unsent document at the time of the subsequent in-memory message transmission**

If in-memory message transmission fails repeatedly when selector 1 is set to "1," the temporary memory will be occupied with image data. Setting selector 2 to "1" will automatically erase the stored 1st-page image data of an unsent document at the time of the subsequent in-memory message transmission only when recording paper or toner runs out.

WSW38 (Function setting 16 in V. 34 mode)

Selector No.	Function	Setting and Specifications
1 2	Setting of the equalizer	No. 1 2 0 X : Automatic 1 0 : Fixed to 4 points 1 1 : Fixed to 16 points
3	Sending level of guard tone at phase 2	0: Normal - 7 db 1: Normal
4	Stepping down the transmission speed at fallback each	0: 2400 bps 1: 4800 bps
5 6	Automatic control of modem's EQM gain for proper transmission speed choice	No. 5 6 0 0 : For higher transmission speed than the current setting 0 1 : No change from the current setting 1 0 : For lower transmission speed than the current setting 1 1 : For further lower transmission than the setting made by 1, 0
7	Redialing when a communications error occurs	0: ON 1: OFF
8	Not used.	

NOTE: WSW38 takes effect only in V. 34 mode.

- **Selectors 1 and 2: Setting of the equalizer**

These selectors set the equalizer's training level to be applied if the facsimile equipment fails to send training due to weak line connection. If these selectors are set to "0, X," the modem will automatically set the appropriate training level.

- **Selector 3: Sending level of guard tone at phase 2**

This selector sets the sending level of guard tone for 1800 Hz to be sent at Phase 2 in the V. 34 mode.

- **Selector 4: Stepping down the transmission speed at fallback each**

This selector determines how much the modem steps down the transmission speed at fallback when called by the remote station. If this selector is set to "1," the modem may step down the transmission speed from 33600 bps to 28800 bps by one-time fallback.

- **Selectors 5 and 6: Automatic control of modem's EQM gain for proper transmission speed choice**

These selectors determine how the modem controls the EQM (Eye Quality Monitor) gain for proper choice of the transmission speed, which applies if the modem selects higher transmission speed than the possible speed so that it always repeats falling back.

WSW39 (Transmission speed setting in V. 34 mode)

Selector No.	Function	Setting and Specifications
1 4	First transmission speed choice for fallback	No. 1 2 3 4 No. 5 6 7 8
		0 0 0 0 : 2400 bps
		0 0 0 1 : 4800 bps
		0 0 1 0 : 7200 bps
		0 0 1 1 : 9600 bps
		0 1 0 0 : 12000 bps
		0 1 0 1 : 14400 bps
		0 1 1 0 : 16800 bps
5 8	Last transmission speed choice for fallback	0 1 1 1 : 19200 bps
		1 0 0 0 : 21600 bps
		1 0 0 1 : 24000 bps
		1 0 1 0 : 26400 bps
		1 0 1 1 : 28800 bps
		1 1 0 0 : 31200 bps
		1 1 0 1 : 33600 bps
		1 1 1 0 : 33600 bps
1 1 1 1 : 33600 bps		

NOTE: WSW39 takes effect only in V. 34 mode. For the transmission speed setting in other modes, refer to WSW19.

• **Selectors 1 through 8: First and last choices of transmission speed for fallback**

These selectors are used to set the modem speed range. With the first transmission speed choice specified by selectors 1 through 4, the equipment attempts to establish the transmission link via the modem. If the establishment fails, the equipment automatically steps down to the next highest speed and attempts to establish the transmission link again. The equipment repeats this sequence while stepping down the transmission speed to the last choice specified by selectors 5 through 8.

If the modem always falls back to a low transmission speed (e.g., 24,000 bps), set the first transmission speed choice to the lower one (e.g., modify it from 31,200 bps to 26,400 bps) in order to deactivate the high-speed modem function and reduce the training time for shorter transmission time.

WSW39 will be limited by selectors 3 through 8 of WSW40.

WSW40 (Function setting 17 in V. 34 mode)

Selector No.	Function	Setting and Specifications			
1 2	Not used.				
3 8	Masking of symbol rate(s)	Not masking		Masking	
		No. 3	0	1	3429 symbols/sec
		No. 4	0	1	3200 symbols/sec
		No. 5	0	1	3000 symbols/sec
		No. 6	0	1	2800 symbols/sec
		No. 7	-	-	Not used.
		No. 8	0	1	2400 symbols/sec

NOTE: WSW40 takes effect only in V. 34 mode.

● **Selectors 3 and 8: Masking of symbol rate(s)**

These selectors allow you to limit the transmission speed range in V. 34 mode by masking the desired symbol rate(s). Transmission speeds assigned to the symbol rates are listed below. The setting made by these selectors will limit the setting made by selectors 1 through 4 of WSW39.

If selector 3 is set to "1" to mask the 3429 symbols/second when the first transmission speed choice is 33600 bps (specified by selectors 1 through 4 of WSW39), for example, then the allowable maximum transmission speed will be limited to 31200 bps. If selector 8 is set to "1" to mask the 2400 symbols/second when the first transmission speed choice is 33600 bps, then the allowable maximum transmission speed remains 33600 bps.

If selector 8 is set to "1" to mask the 2400 symbols/second when the first transmission speed choice is 21600 bps (specified by selectors 1 through 4 of WSW39), then the allowable maximum transmission speed remains 21600 bps but the minimum transmission speed will be limited to 4800 bps.

Symbol rate	Transmission speed (bps)	Symbol rate	Transmission speed (bps)	Symbol rate	Transmission speed (bps)
2400	2400	3000	4800	3429	4800
	4800		7200		7200
	7200		9600		9600
	9600		12000		12000
	12000		14400		14400
	14400		16800		16800
	16800		19200		19200
	19200		21600		21600
	21600		24000		24000
	21600		24000		24000
2800	4800	3200	4800		4800
	7200		7200		7200
	9600		9600		9600
	12000		12000		12000
	14400		14400		14400
	16800		16800		16800
	19200		19200		19200
	21600		21600		21600
	24000		24000		24000
	26400		26400		26400
	26400		26400		26400
	26400		28800		28800
	26400		31200		31200
	26400		31200		31200

WSW41 (CCD fluorescent lamp and modem attenuator in V. 34 mode)

Selector No.	Function	Setting and Specifications
1 3	ON-duration of the fluorescent lamp built in the CCD unit	No. 1 2 3 0 0 0 : 16 hours 0 0 1 : 24 hours 0 1 0 : 12 hours 0 1 1 : 8 hours 1 0 0 : 4 hours 1 0 1 : 2 hours 1 1 0 : 10 minutes 1 1 1 : 0 minute
4	Not used.	
5 8	Modem attenuator	No. 5 6 7 8 0 0 0 0 : -10 dBm 0 0 0 1 : -11 dBm 0 0 1 0 : -12 dBm 0 0 1 1 : -13 dBm 0 1 0 0 : -14 dBm 1 1 1 1 : -25 dBm

NOTE: Selectors 1 through 3 are applicable only to models equipped with a flat-bed scanner.

NOTE: Selectors 5 through 8 take effect only in V. 34 mode.

- **Selectors 1 through 3: ON-duration of the fluorescent lamp built in the CCD unit**

If the scanning operation is started when the fluorescent lamp is off, then the lamp will come on and stay on for the time length specified by these selectors.

If these selectors are set to "1, 1, 1," the fluorescent lamp will go off after the scanning sequence.

- **Selectors 5 through 8: Modem attenuator**

These selectors are used to adjust the transmitting level of the modem when the reception level at the remote station is improper due to line loss. This function applies to super G3 protocol signals.

WSW42 (Function setting 18)

Selector No.	Function	Setting and Specifications
1	Incoming mail server POP* ¹	0: OFF 1: ON
2	Incoming mail server SMTP* ²	0: OFF 1: ON
3	Internet-FAX forward function	0: OFF 1: ON
4	JBIG* ³ coding system	0: Disabled 1: Enabled
5 8	Not used.	

*¹ POP: Post Office Protocol
 *² SMTP: Simple Mail Transfer Protocol
 *³ JBIG: Joint Bi-level Image Group

NOTE: Selectors 1 through 3 are applicable to those models equipped with LAN interface.

- **Selector 3: Internet-FAX forward function**

If this selector is set to "ON," the machine may forward a FAX message received through Internet to other remote G3 facsimile equipment.

WSW43 (Function setting 19)

Selector No.	Function	Setting and Specifications
1	Not used.	
2 3	Wait time for PCFax reception (Class 2) and FPTS command transmission	No. 2 3 0 0 : 50 ms 0 1 : 100 ms 1 0 : 150 ms 1 1 : 0 ms
4 5		No. 4 5 0 0 : 200 ms 0 1 : 300 ms 1 0 : 400 ms 1 1 : 500 ms
6 8		Not used.

WSW44 (Speeding up scanning-1)

Selector No.	Function	Setting and Specifications
1 5	Not used.	
6 8	Effective time length of the white level compensation data obtained beforehand	No. 6 7 8 0 0 0 : Obtained compensation data ineffective 0 0 1 : 1 min. 0 1 0 : 3 min. 0 1 1 : 5 min. 1 0 0 : 10 min. 1 0 1 : 15 min. 1 1 0 : 20 min. 1 1 1 : 30 min.

NOTE: WSW44 is applicable only to models equipped with a flat-bed scanner.

- **Selectors 6 through 8: Effective time length of the white level compensation data obtained beforehand**

If you set documents in the ADF and the document front sensor detects them or if you open the document tray ASSY and the document tray open sensor detects the open state, then the controller will make correction of the reference voltage to be applied to white level compensation for document scanning before the Copy button is pressed.

These selectors determine how long compensation data obtained beforehand will keep effective.

WSW45 (Speeding up scanning-2)

Selector No.	Function	Setting and Specifications
1 3	Delay time from when documents are set until the ADF starts drawing them in	No. 1 2 3 0 0 0 : No automatic drawing-in 0 0 1 : 1 sec. 0 1 0 : 2 sec. 0 1 1 : 3 sec. 1 0 0 : 4 sec. 1 0 1 : 5 sec. 1 1 0 : 6 sec. 1 1 1 : 7 sec.
4 6	Periodical correction intervals of the reference voltage to be applied to white level compensation for document scanning, during standby	No. 4 5 6 0 0 0 : No correction of reference voltage during standby 0 0 1 : 10 sec. 0 1 0 : 30 sec. 0 1 1 : 1 min. 1 0 0 : 3 min. 1 0 1 : 5 min. 1 1 0 : 10 min. 1 1 1 : 30 min.
7 8	Not used.	

NOTE: WSW45 is applicable only to models equipped with a flat-bed scanner.

- **Selectors 1 through 3: Delay time from when documents are set until the ADF starts drawing them in**

These selectors determine how long the ADF will delay automatic drawing-in of documents (to the scanning standby position) after you set them in the ADF, as well as determining whether or not the ADF automatically draws in documents.

- **Selectors 4 through 6: Periodical correction intervals of the reference voltage applied to white level compensation for document scanning, during standby**

These selectors set the correction intervals (in seconds) of the reference voltage to be applied to white level compensation for document scanning during standby, as well as determining whether or not the controller makes the reference voltage correction during standby. (Conventionally, the correction has been made immediately before the start of actual scanning)

This function takes effect in copying. Making the correction during standby may shorten the preparation time for copying.

NOTE: Do not access these selectors.

WSW46 (Monitor of PC ON/OFF state and parallel port kept at high)

Selector No.	Function	Setting and Specifications
1 2	Monitoring the PC ON/OFF state	No. 1 2 0 0 : Disabled 0 1 : Monitor SELECT IN 1 0 : Monitor STROBE 1 1 : Monitor both SELECT IN and STROBE
3	Parallel port output pins kept at high level	0: Enabled 1: Disabled
4 8	Not used.	

NOTE: Selector 3 is applicable only to models equipped with a parallel interface.

- **Selectors 1 and 2: Monitoring the PC ON/OFF state**

For the related functions, refer to WSW36, selectors 2 and 3.

- **Selector 3: Parallel port output pins kept at high level**

Setting this selector to "0" will keep all parallel output pins of the facsimile equipment at high level. Use this setting if Resource Manager (bundled with MFC models) installed to WindowsNT running on the connected PC fails to monitor the power ON/OFF state of the facsimile equipment.

FAX2800/FAX2900/FAX3800/MFC4800 FAX8070P/MFC9030/MFC9070

Appendix 3. Circuit Diagrams

- A. Main PCB
- B. Network Control Unit (NCU) PCB
- C. Control Panel PCB
- D. Power Supply PCBs

NOTE: Terms in circuit diagrams

セラC: Ceramic capacitor

デンC: Chemical capacitor

A. Main PCB (1/5)

1. FOR PCB: B03K0527-7
 2. 指示なき部材は、セラミックコンデンサのサイズは 1608

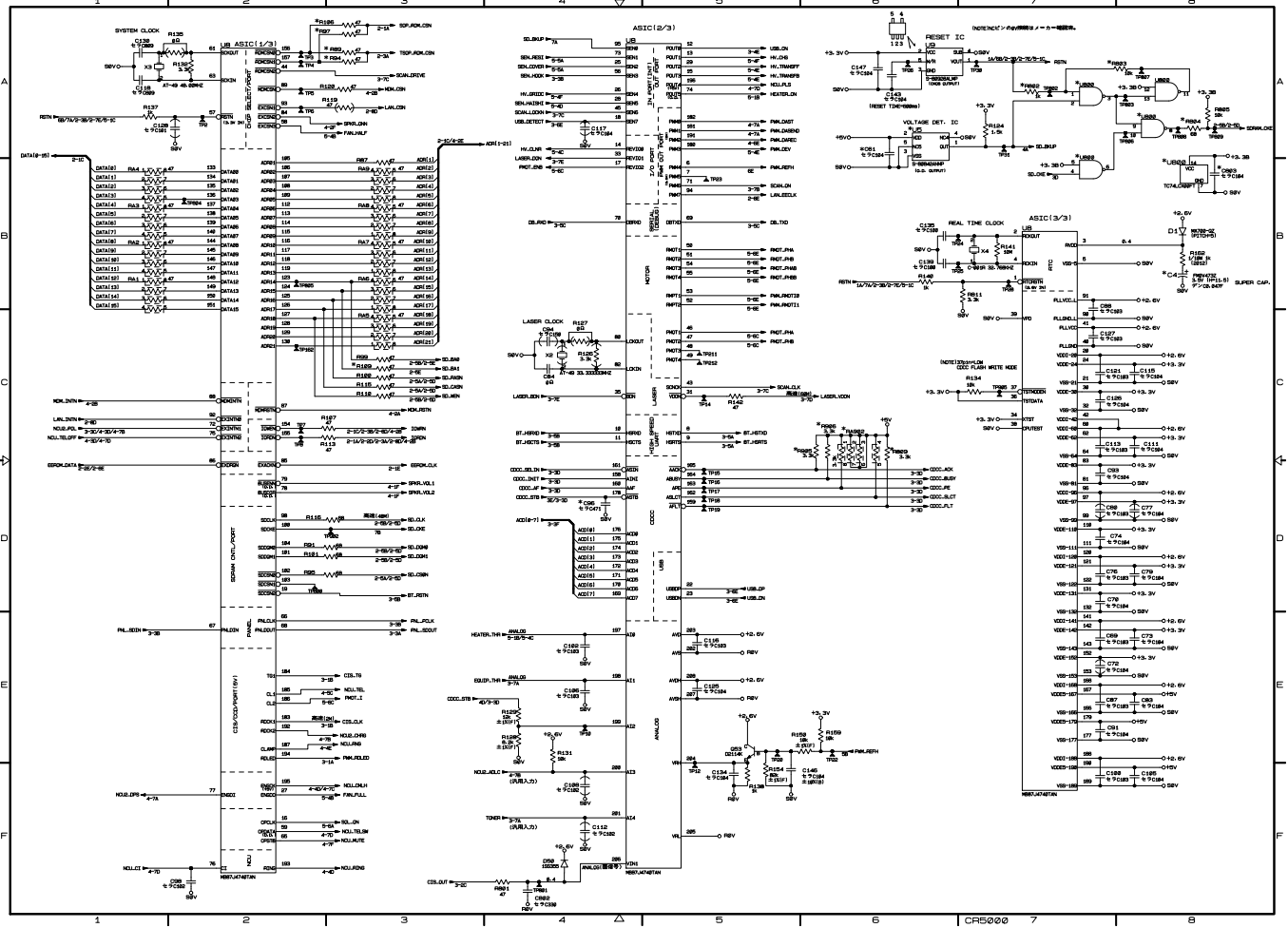

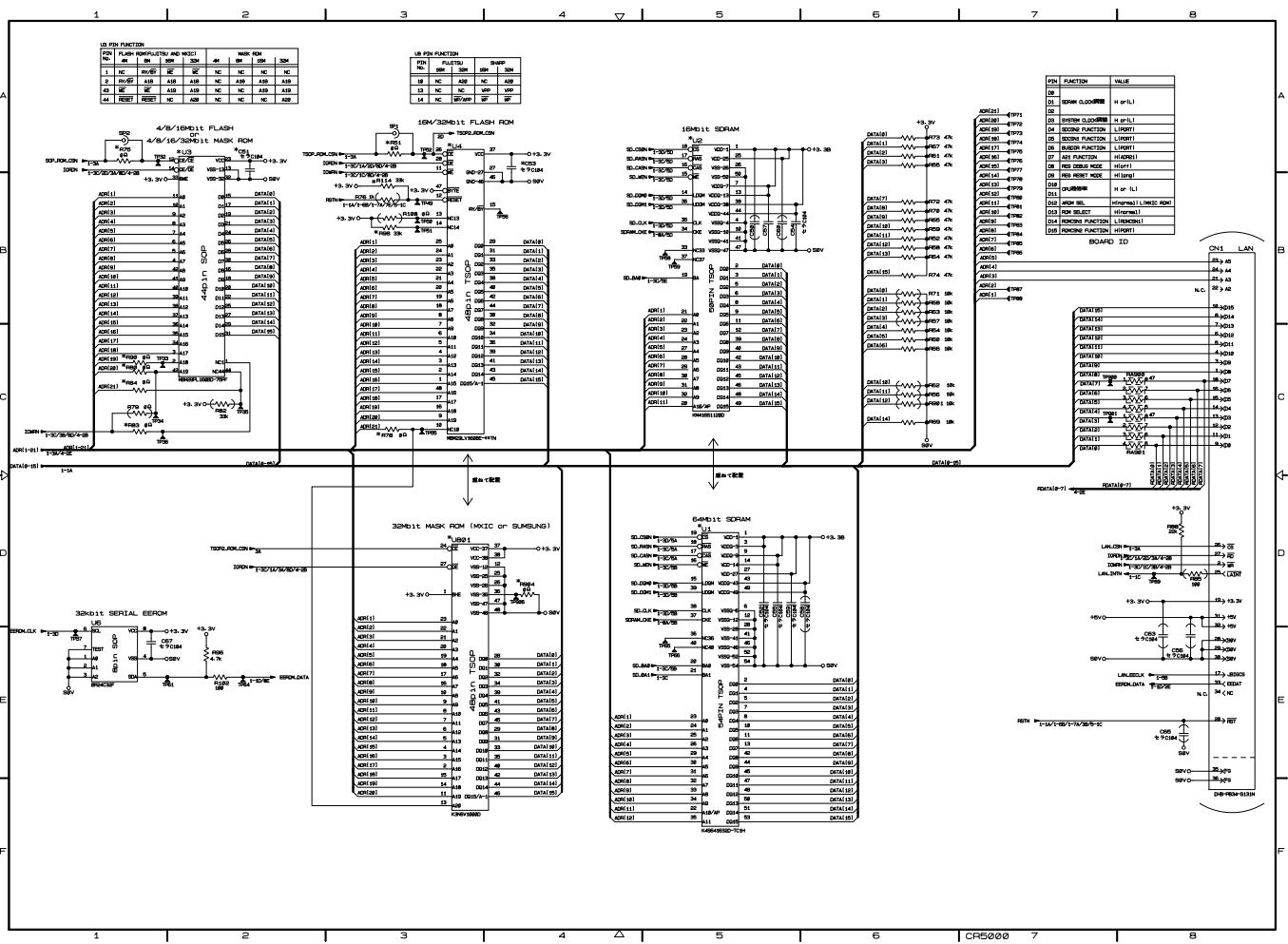

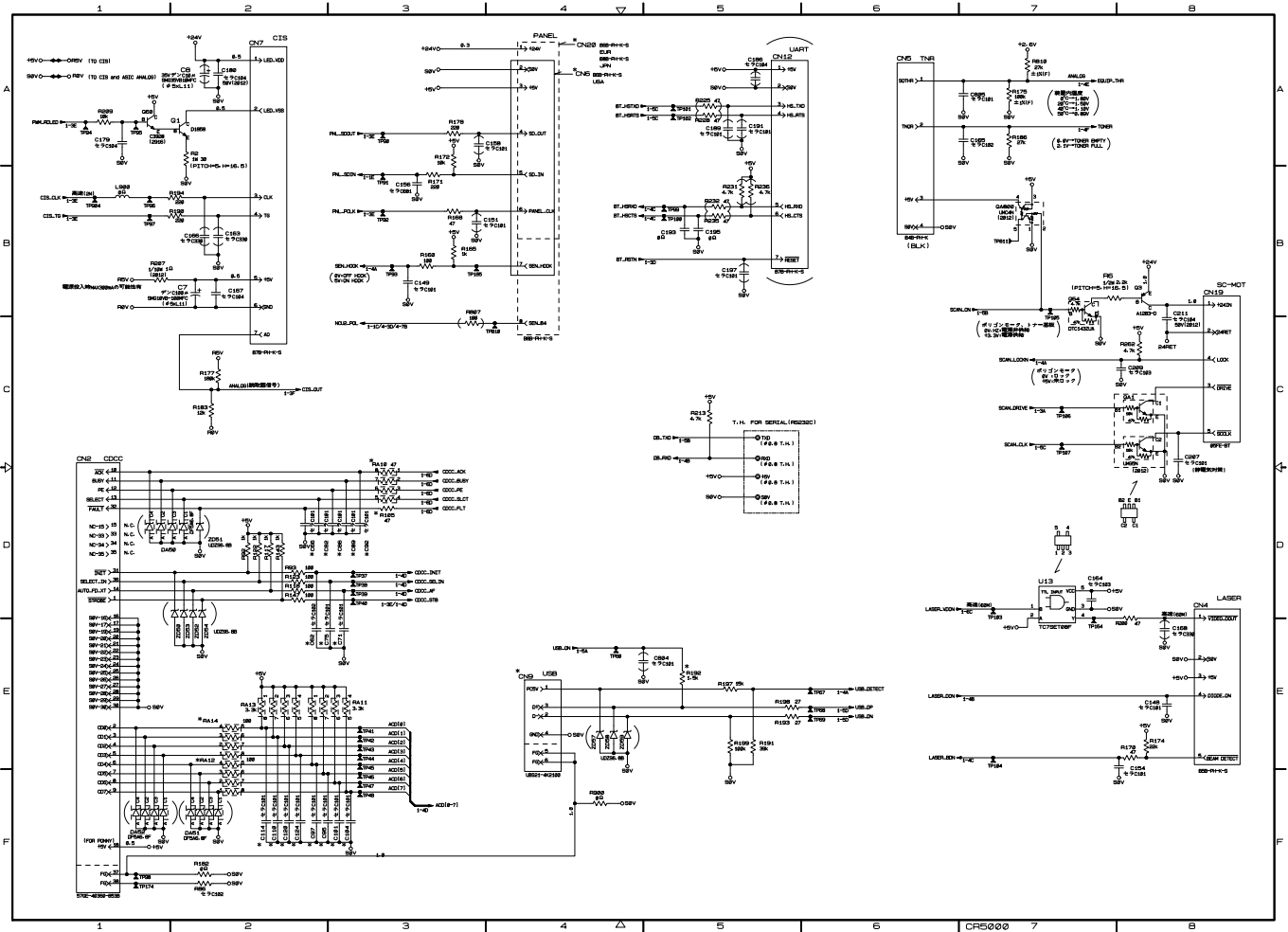

A. Main PCB (4/5)

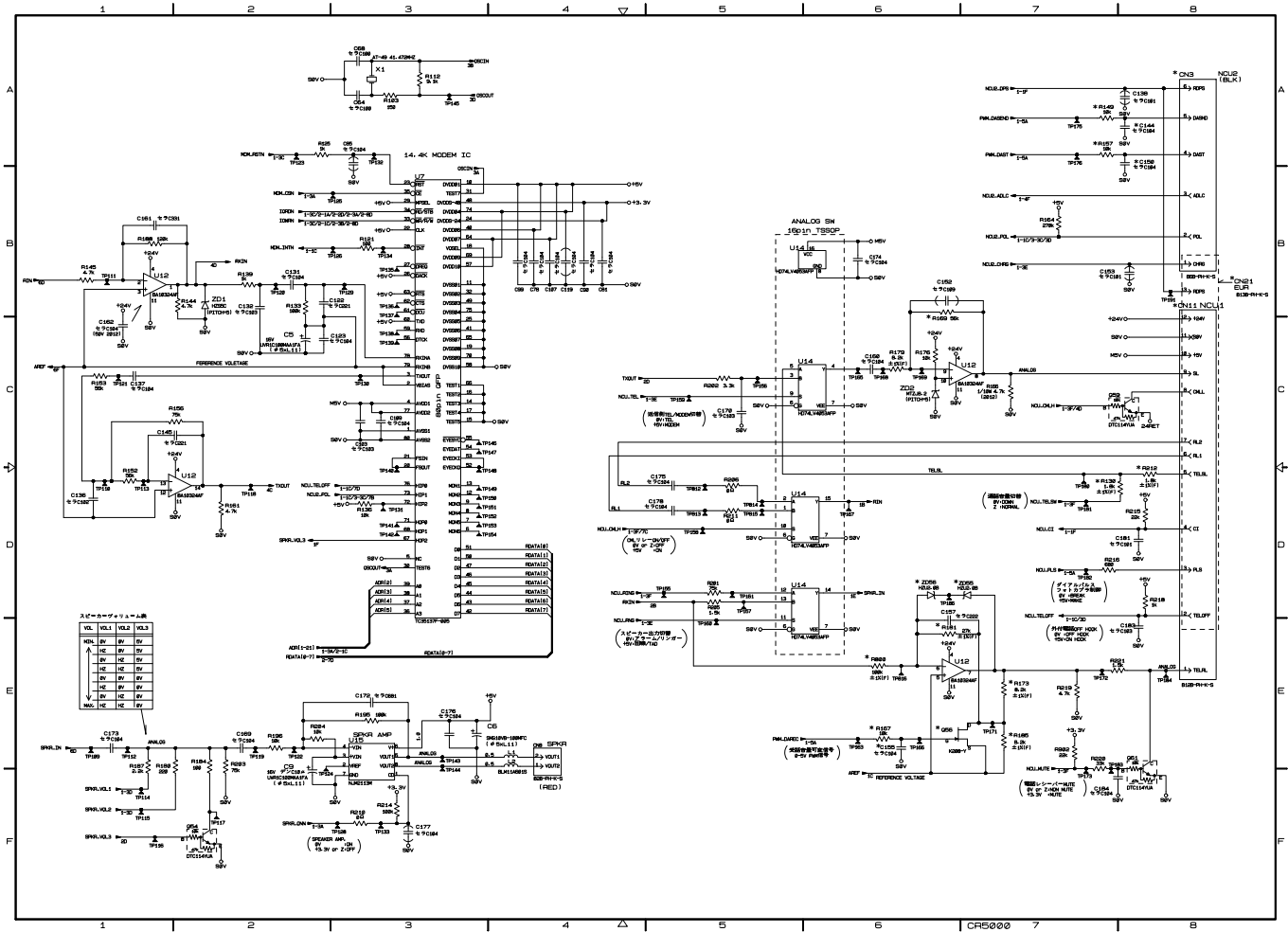

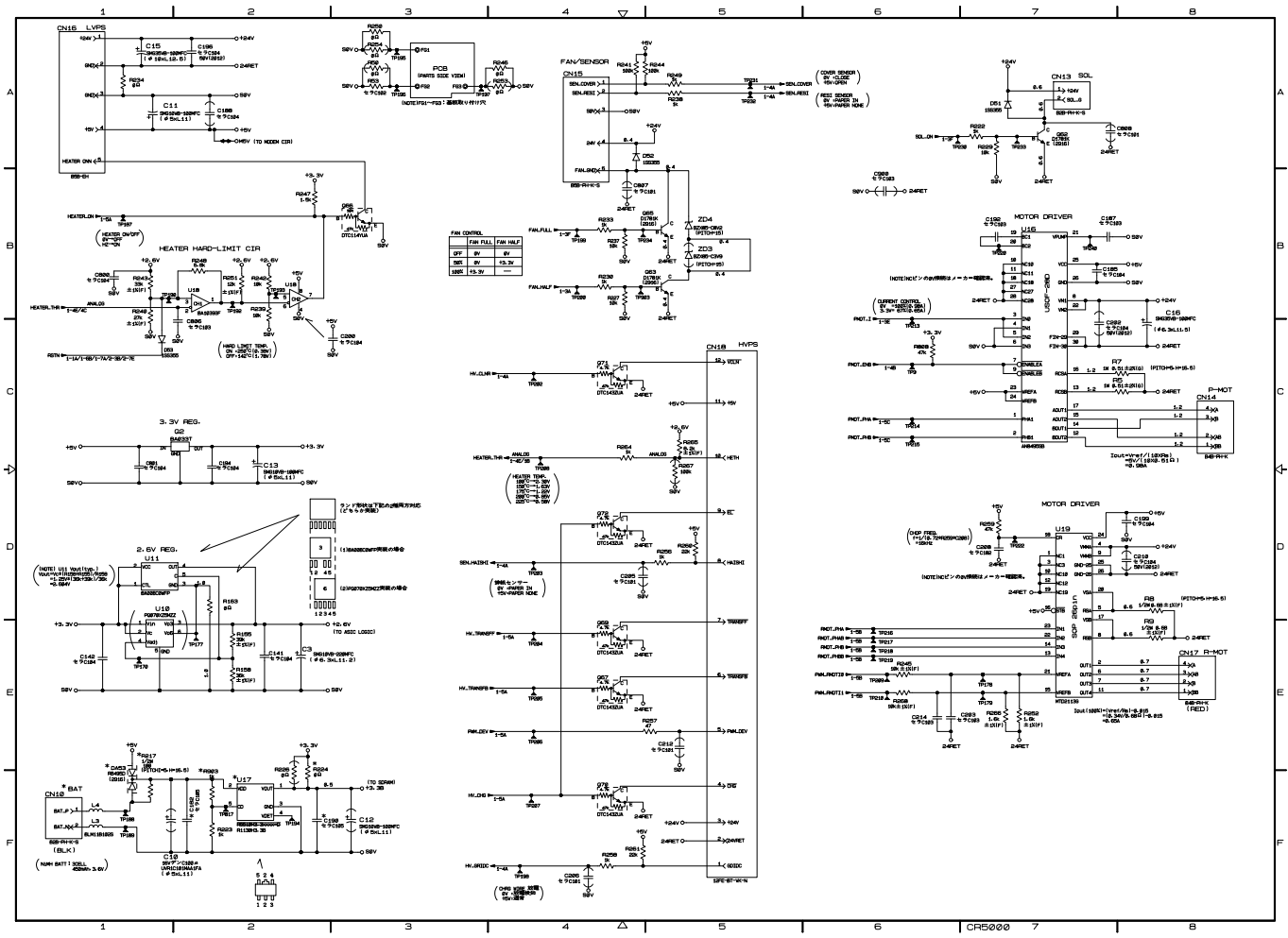

B. NCU PCB
(U.S.A., Canada)

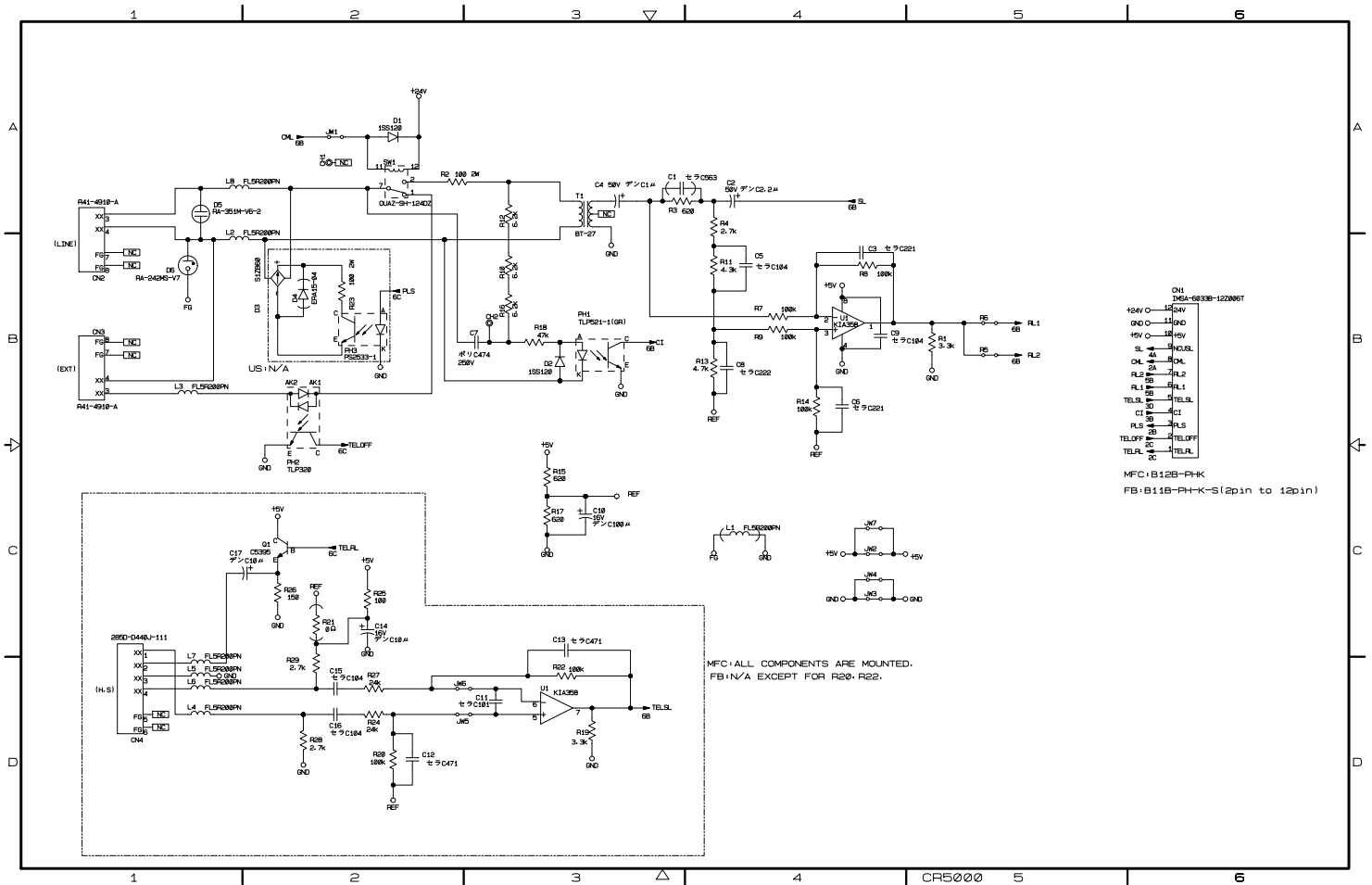

B. NCU PCB
 (U.K., Norway, Netherlands, Finland, Denmark, Sweden)

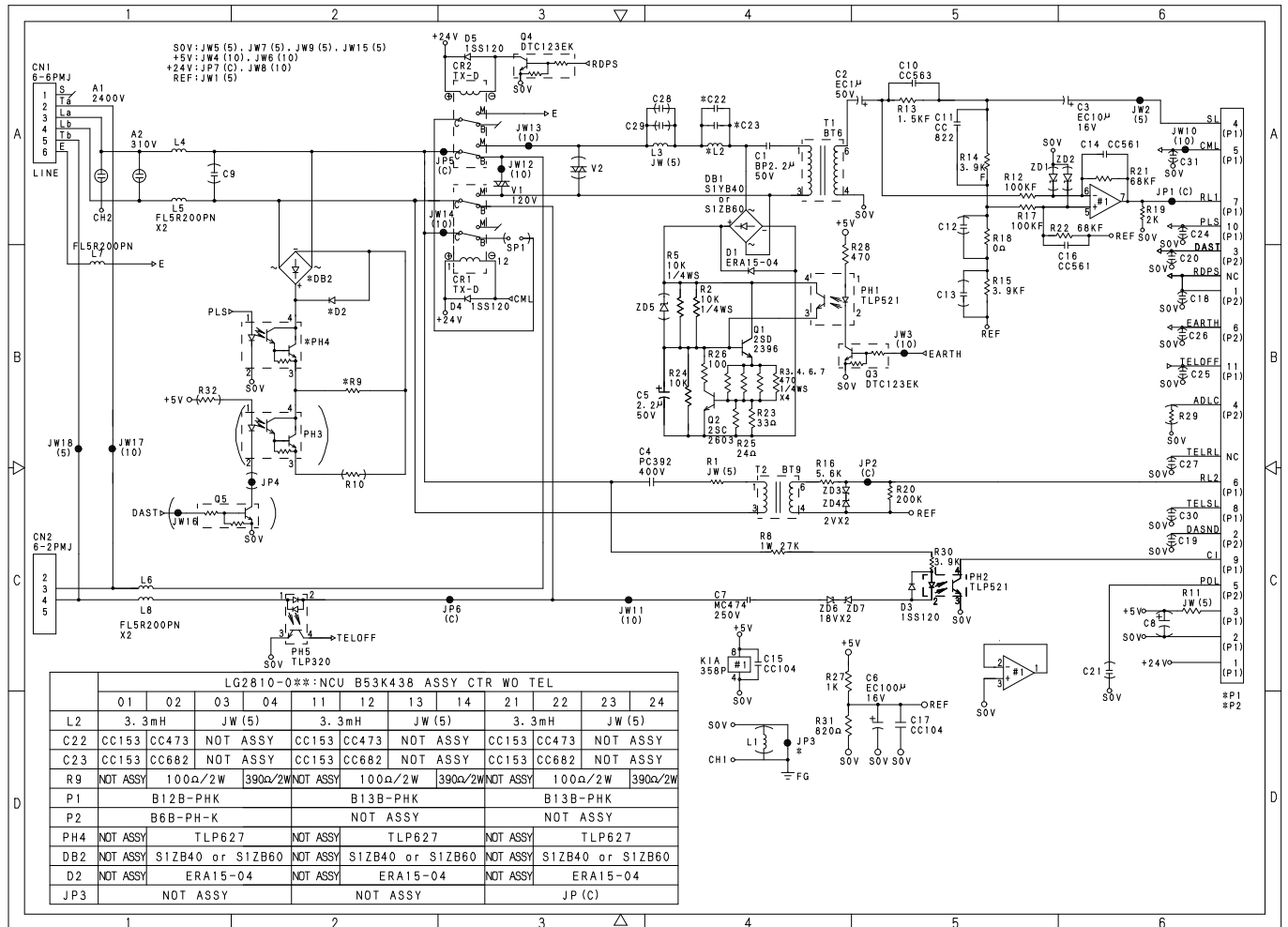

B. NCU PCB
 (Germany, France, Belgium, Switzerland, Ireland,
 Austria, Spain, Italy, South Africa)

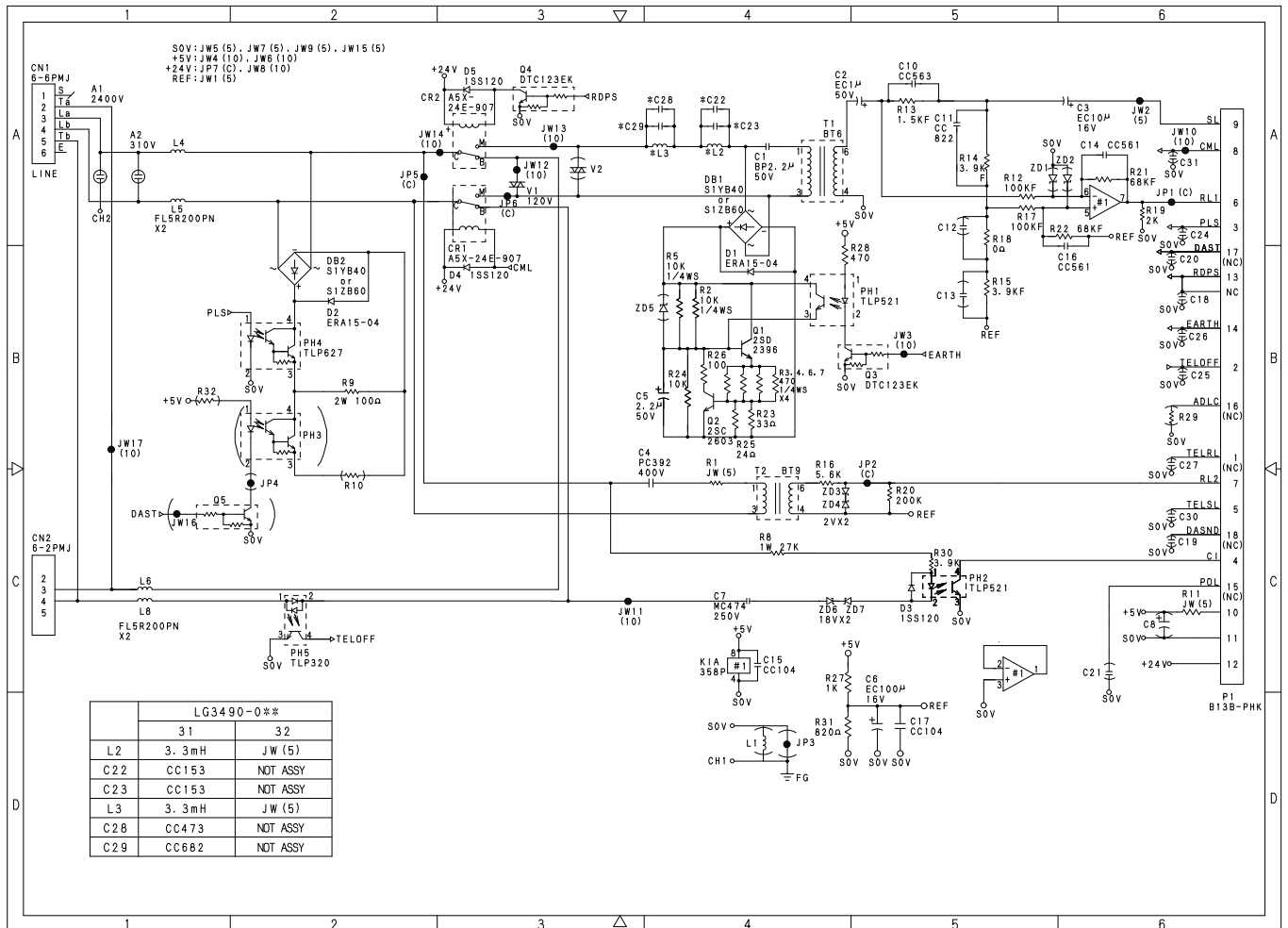

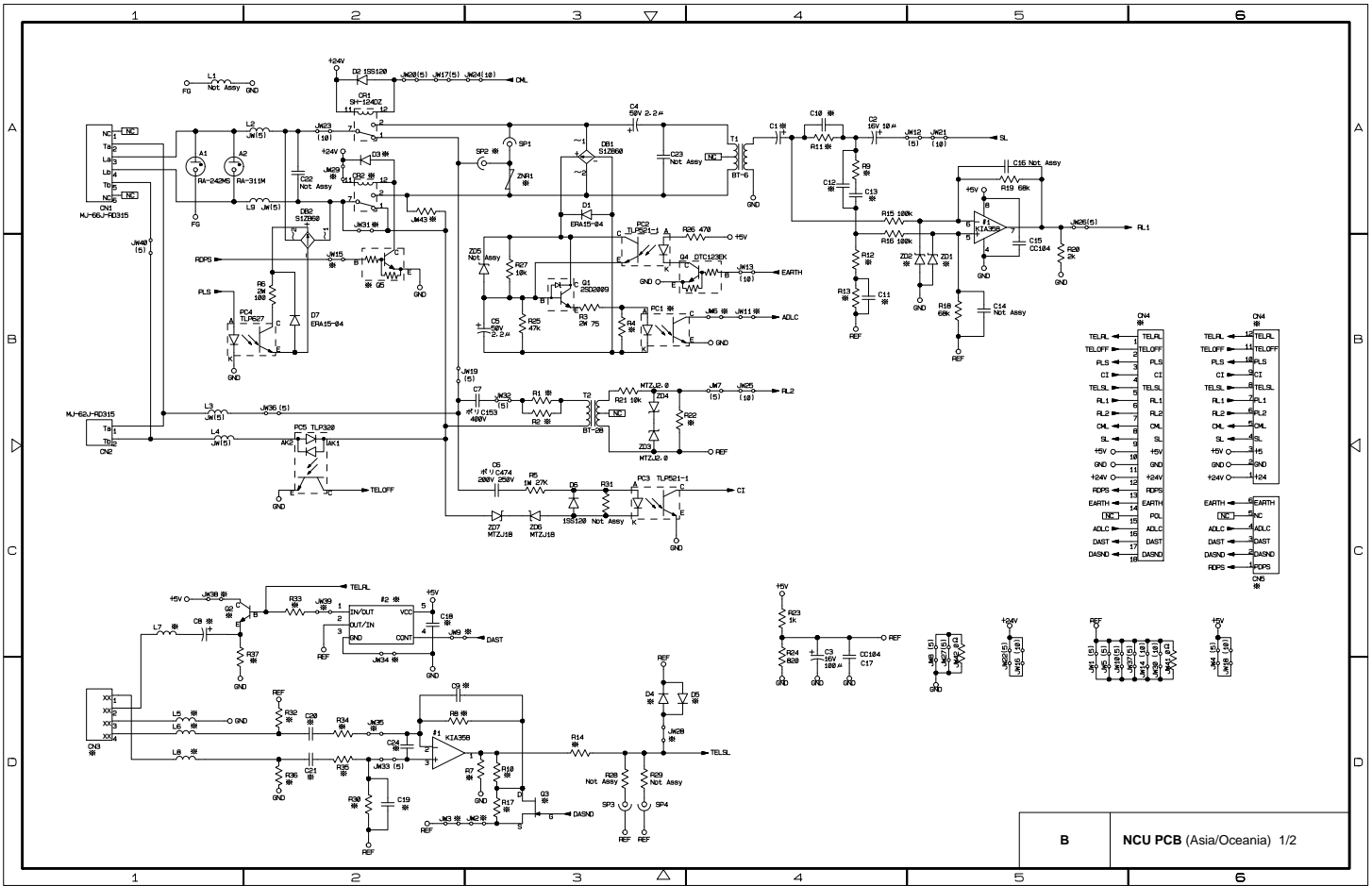

B NCU PCB (Asia/Oceania) 1/2

ASSY	NCU B53K479 ASSY OCE	NCU B53K479 ASSY ASA
ADRS.	NAME	NAME
ZNR1	ENC121D07A	Not Assy
SP2	1/16W 0	Not Assy
CR2	SH-124DZ	Not Assy
Q5	DTC123EK	Not Assy
D3	1SS120	Not Assy
JW15	JW(10)	Not Assy
JW29	JW (5)	Not Assy
JW31	Not Assy	JW (5)
JW43	Not Assy	1/16W 0
PC1	Not Assy	TLP521-1G
R4	JW (5)	1/4W 20
JW6;JW11	Not Assy	JW (5)
ZD1;ZD2	Not Assy	MTJ5.1B
R1	Not Assy	1/4W 22K
R2	JW (5)	1/4W 22K
R9	1/16W 1% 2.7K	1/16W 1% 4.7K
R11	1/16W 1% 1.10K	1/16W 1% 910
R12	CERAMIC 16C224B	1/16W 1% 2K
R13	1/16W 1% 3.9K	1/16W 1% 9.1K
R22	1/16W 20K	Not Assy
C1	ALUM-ELEC 50B10-1	ALUM-ELEC 16B100
C10	CERAMIC 50C563B	Not Assy
C11	Not Assy	CERAMIC 50C103B
C12	CERAMIC 50C562B	Not Assy
C13	RESISTOR 0	CERAMIC 16C224B
CN3	MODULAR 4-4P	MODULAR 4-4P
CN5	B6B-PH	B6B-PH
CN4	B12B-PH	B12B-PH
Q2	2SC5395	2SC5395
R7	1/16W 680	1/16W 680
R8;R30	1/16W 1% 270K	1/16W 1% 100K
R14	1/16W 1% 1.6K	1/16W 1% 1K
R32;R36	1/16W 1K	1/16W 1K
R34;R35	1/16W 1% 13K	1/16W 1% 20K
R37	1/16W 150	1/16W 150
C8	ALUM-ELEC 16B100	ALUM-ELEC 16B100
C9;C19	CERAMIC 50C391B	CERAMIC 50C821B
C20;C21	CERAMIC 25C104B	CERAMIC 25C104B
C24	CERAMIC 50C101B	CERAMIC 50C101B
JW35;JW38;L5;L6;L7;L8	JW (5)	JW (5)
D4;D5	1SS120	Not Assy
JW28	JW (5)	Not Assy
#2	Not Assy	TC7S66F
R33	Not Assy	1/16 1% 1.3K
C18	Not Assy	CERAMIC 25C104
JW9;JW34;JW39	Not Assy	JW (5)
Q3	Not Assy	2SK208
R10	1/16W 0	1/16W 1% 1K
R17	Not Assy	1/16W 1% 680
JW2;JW3	Not Assy	JW (5)

B

NCU PCB (Asia/Oceania) 2/2

C. Control Panel PCB

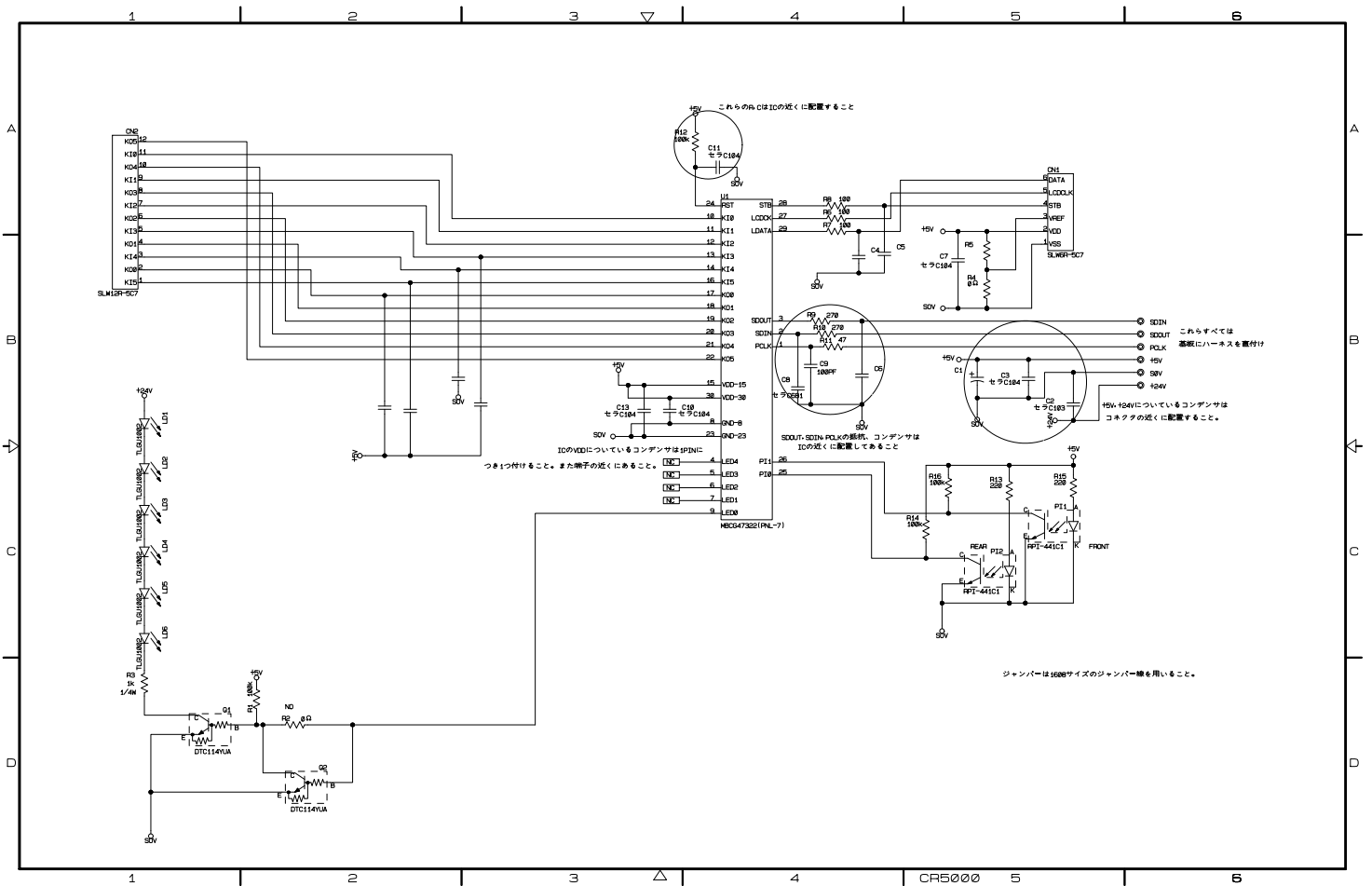

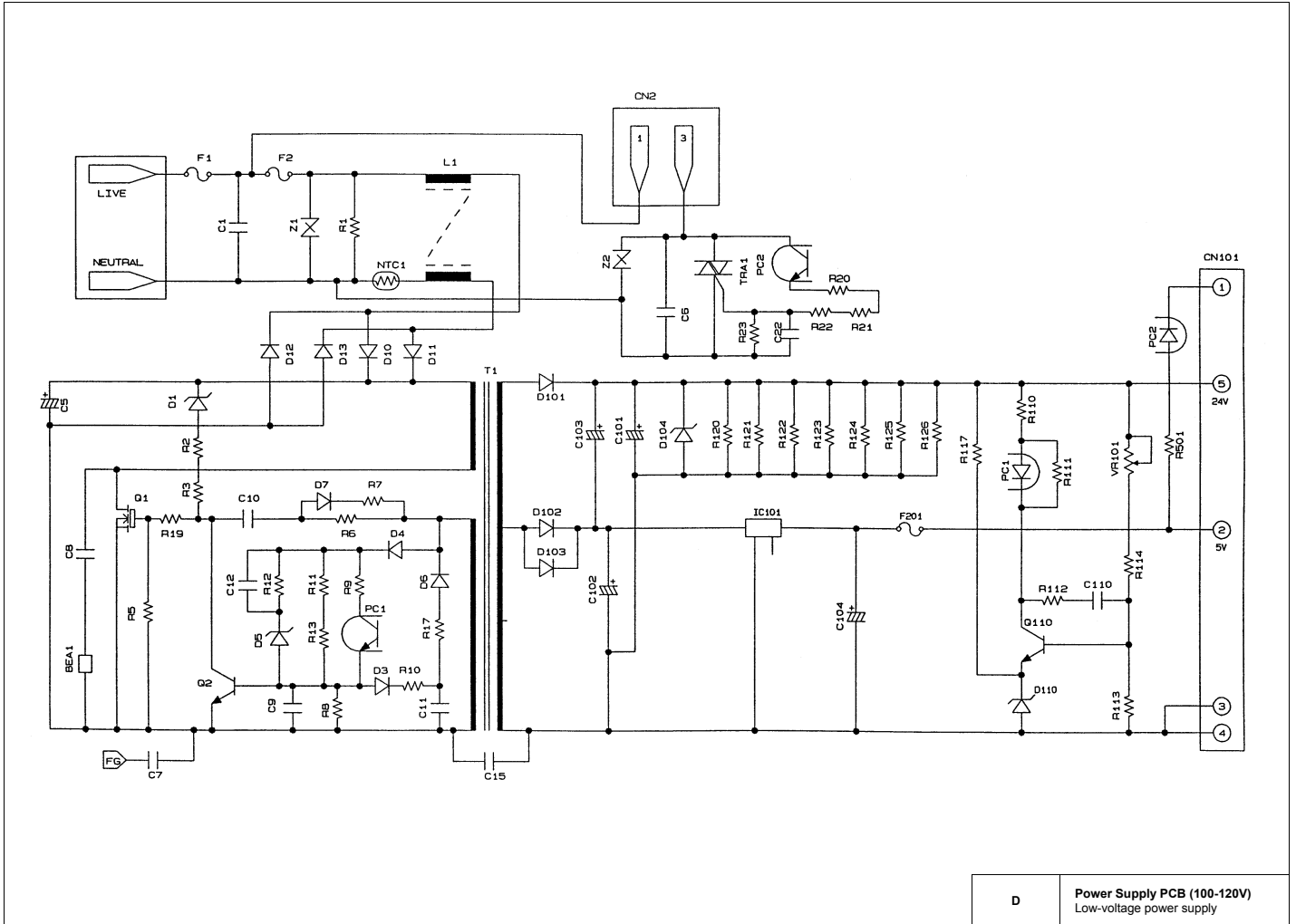

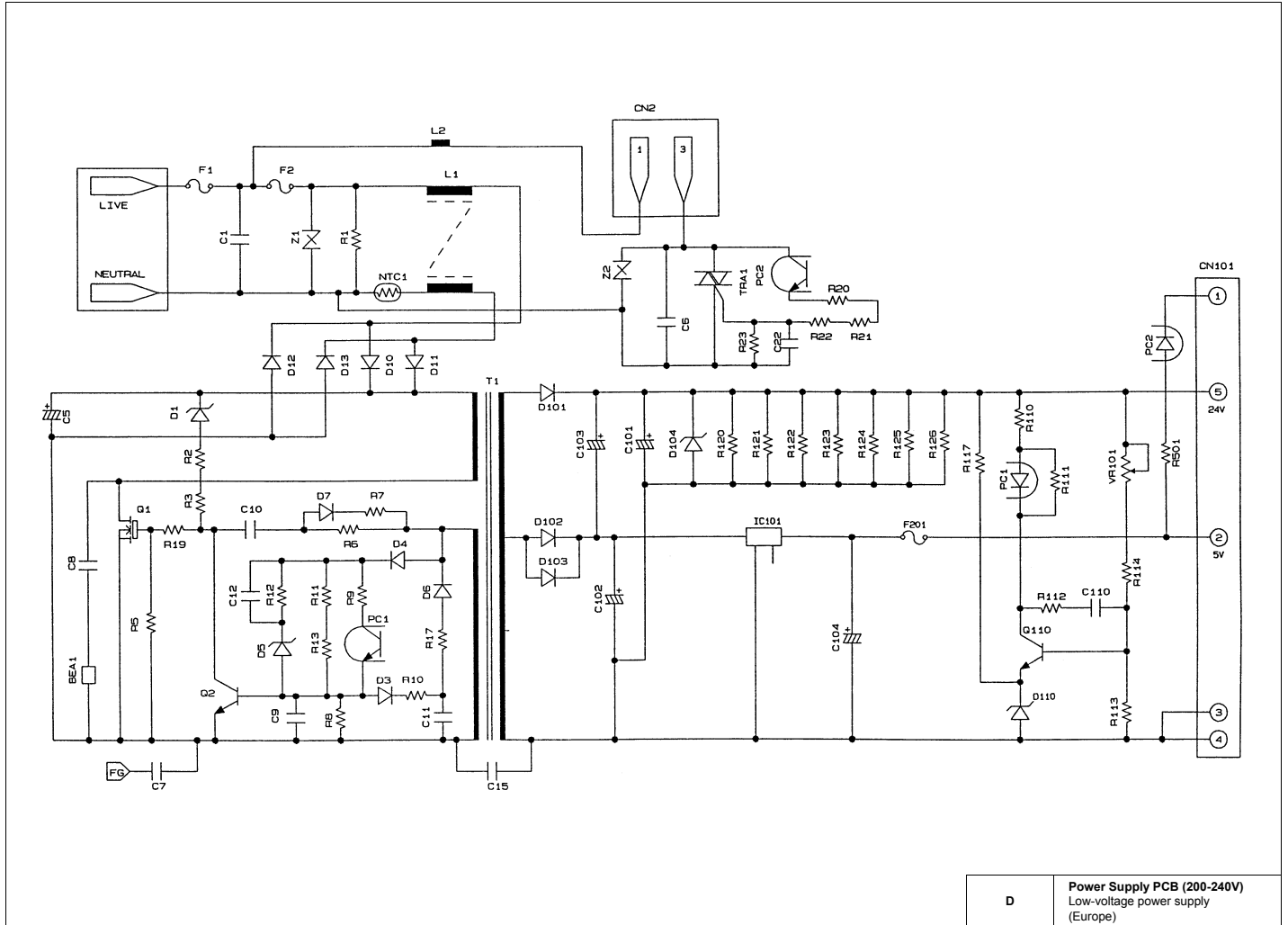

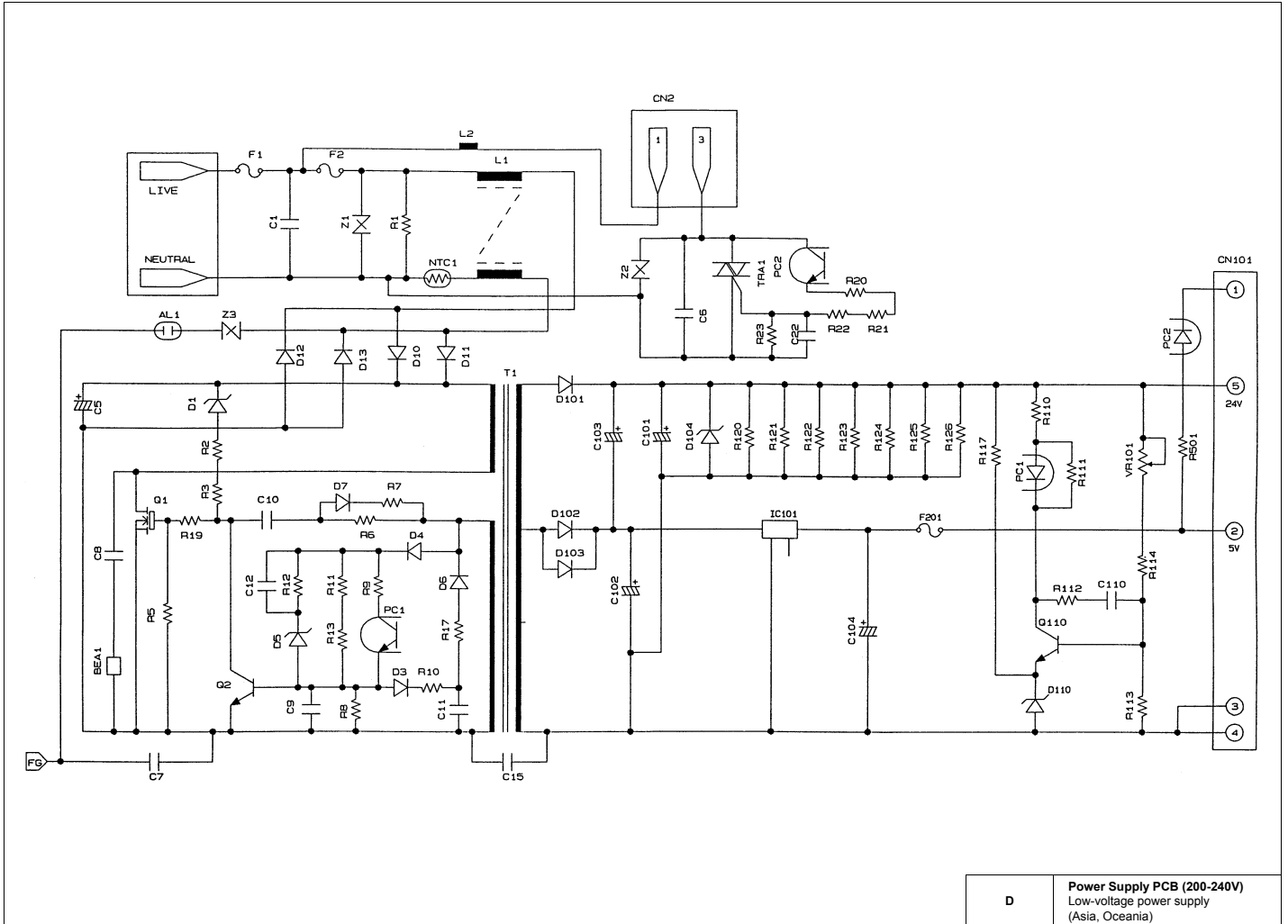

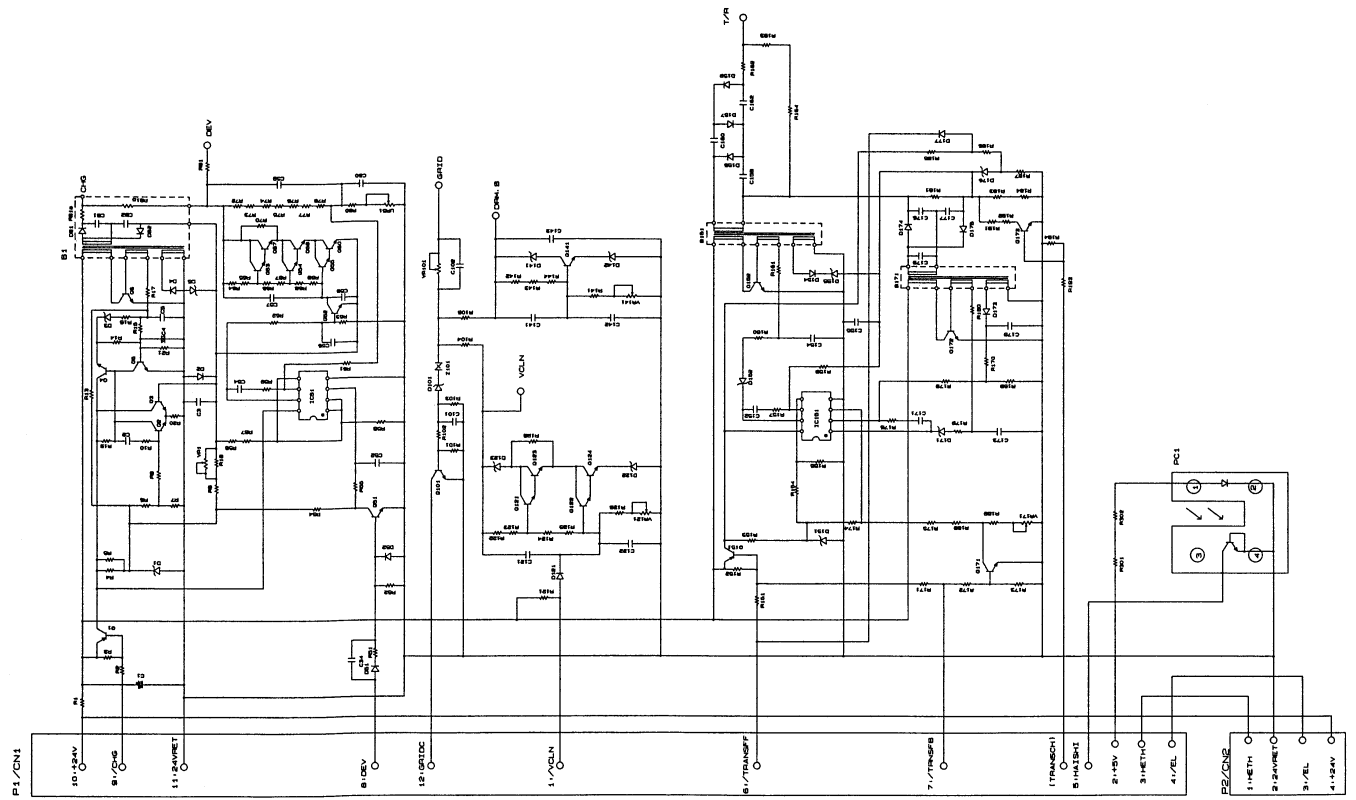

D	Power Supply PCB High-voltage power supply
---	--

brother®

April '02
SM-FAX002②
8X5601
Printed in Japan