



**FACSIMILE EQUIPMENT  
SERVICE MANUAL**

**MODEL: MFC8500/FAX4100/FAX4750e/FAX5750e  
MFC9660/FAX8360P**

© Copyright Brother 2002

All rights reserved.

No part of this publication may be reproduced in any form or by any means without permission in writing from the publisher.

Specifications are subject to change without notice.

All products and company names mentioned in this manual are trademarks or registered trademarks of their respective holders.

## **PREFACE**

This publication is a Service Manual covering the specifications, construction, theory of operation, and maintenance of the Brother facsimile equipment. It includes information required for field troubleshooting and repair--disassembly, reassembly, and lubrication--so that service personnel will be able to understand equipment function, to rapidly repair the equipment and order any necessary spare parts.

To perform appropriate maintenance so that the facsimile equipment is always in best condition for the customer, the service personnel must adequately understand and apply this manual.

This manual is made up of six chapters and appendices.

<b>CHAPTER I.</b>	<b>GENERAL DESCRIPTION</b>
<b>CHAPTER II.</b>	<b>INSTALLATION</b>
<b>CHAPTER III.</b>	<b>THEORY OF OPERATION</b>
<b>CHAPTER IV.</b>	<b>DISASSEMBLY/REASSEMBLY AND LUBRICATION</b>
<b>CHAPTER V.</b>	<b>MAINTENANCE MODE</b>
<b>CHAPTER VI.</b>	<b>ERROR INDICATION AND TROUBLESHOOTING</b>
<b>Appendix 1.</b>	<b>EEPROM Customizing Codes</b>
<b>Appendix 2.</b>	<b>Firmware Switches (WSW)</b>
<b>Appendix 3.</b>	<b>Circuit Diagrams</b>
<b>Appendix 4.</b>	<b>Toner Cartridge Weight</b>

This manual describes the models and their versions to be destined for major countries. The specifications and functions are subject to change depending upon each destination.

## **SAFETY INFORMATION**

### **Laser Safety (110-120V Model only)**

This printer is certified as a Class 1 laser product under the US Department of Health and Human Services (DHHS) Radiation Performance Standard according to the Radiation Control for Health and Safety Act of 1968. This means that the printer does not produce hazardous laser radiation.

Since radiation emitted inside the printer is completely confined within the protective housings and external covers, the laser beam cannot escape from the machine during any phase of user operation.

### **CDRH Regulations (110-120V Model only)**

The Center for Device and Radiological Health (CDRH) of the US Food and Drug Administration implemented regulations for laser products on August 2, 1976. These regulations apply to laser products manufactured from August 1, 1976. Compliance is mandatory for products marketed in the United States. The label shown below indicates compliance with the CDRH regulations and must be attached to laser products marketed in the United States.

The label for Chinese products

MANUFACTURED: JULY 1999 C
BROTHER CORP. (ASIA) LTD.
BROTHER BUJI NAN LING FACTORY
Gold Garden Industry, Nan Ling Village, Buji,
Rong Gang, Shenzhen, China.
This product complies with FDA radiation
performance standards, 21 CFR Subchapter J.

# **CHAPTER I.**

## **GENERAL DESCRIPTION**

# CHAPTER I. GENERAL DESCRIPTION

## CONTENTS

<b>1.</b>	<b>EQUIPMENT OUTLINE .....</b>	<b>I-1</b>
1.1	External Appearance and Weight.....	I-1
1.2	Components .....	I-1
<b>2.</b>	<b>SPECIFICATIONS.....</b>	<b>I-2</b>

# 1. EQUIPMENT OUTLINE

## 1.1 External Appearance and Weight

The figure below shows the equipment appearance and approximate dimensions.

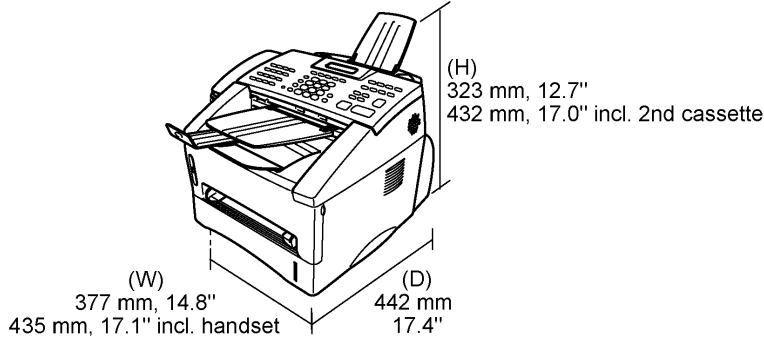

Weight:		w/o 2nd cassette	w/ 2nd cassette
Machine proper		10.5 kg	14.0 kg
Machine (incl. drum unit & toner cartridge)		12.0 kg	15.5 kg
In package		16.5 kg	22.0 kg

## 1.2 Components

The equipment consists of the following major components:

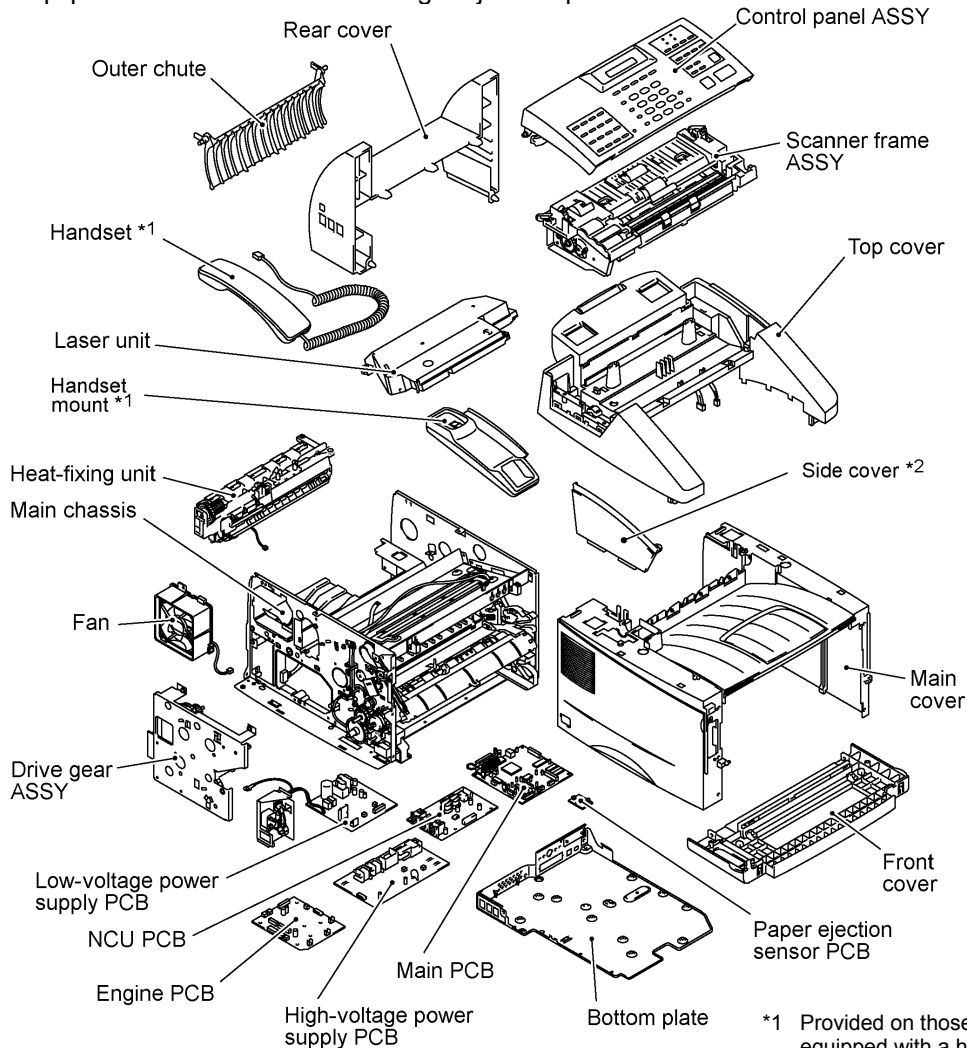

\*1 Provided on those models equipped with a handset.

\*2 Provided on those models without handset.

## 2. SPECIFICATIONS

(1/4)

Model Name	MFC8500	F AX4100
<b>GENERAL</b>		
Print Engine	Laser (ZLe)	Laser (ZLe)
Modem Speed(bps)	14,400(Fax)	<b>14,400(Fax)</b>
Transmission Speed(sec.)	Approx. 6	<b>Approx. 6</b>
ITU-T Group	G3	G3
Coding Method	MH/MR/MMR	<b>MH/MR/MMR</b>
Input/Output Width	5.8"-8.5"/2.75"-8.5"	5.8"-8.5"/2.75"-8.5"
ADF(pages)	30	30 (50:Conditional *1)
LCD Size	16 Characters x 2 Lines	16 Characters x 2 Lines
On-Screen Programming	Yes	Yes
Backup Clock	Yes (9 hours)	Yes (9 hours)
Memory Capacity(MB)	8 MB	8 MB
Backup Memory	N / A	N / A
Memory Security	N / A	N / A
Optional Memory	N / A	N / A
Paper Capacity(sheets)	250	250
Additional Paper Capacity(sheets)	250 (User Option)	250 (User Option)
Dimensions (WxDxH)	17.1x17.4x12.7 inches 435x442x323 mm	17.1x17.4x12.7 inches 435x442x323 mm
Weight	26.4 lbs/(12 kg)	26.4 lbs/(12 kg)
Color	Gray 1495	Gray 1495
Standby Mode	Yes	Yes
<b>PC-Fax Protocol Compliance</b>	Class 2	N / A
Simultaneous Operation	Yes	Yes
Data Modem	N / A	N / A
Energy Star Compliance (for U.S.A.)	Yes	Yes
LCD Back Light	N / A	N / A
Operating Environment Temperature	10 - 32.5 degrees Centigrade	10 - 32.5 degrees Centigrade
Humidity	20 - 80%(without condensation)	20 - 80%(without condensation)
Power Source	120VAC 50/60Hz	120VAC 50/60Hz
Power Consumption (Sleep/Standby/Peak)	Less than 10W / 70W / 940W	Less than 10W / 70W / 940W
Toner Life (Standard Yield : TN-430) (High Yield : TN-460)	3,000 A4 pages@5% 6,000 A4 pages@5%	3,000 A4 pages@5% 6,000 A4 pages@5%
Drum Life (DR-400)	up to 20,000 pages	up to 20,000 pages
Bundled Cable	N / A	N / A
<b>TELEPHONE</b>		
Automatic Redial	Yes	Yes
Handset	Yes	Yes
One-Touch Dial	16 (8x2)	32 (16x2)
Speed Dial	100	<b>100</b>
Telephone Index	Yes	Yes
Speaker Phone	N / A	N / A
Chain Dialing	Yes	Yes
Caller ID	Yes	Yes
Call Waiting Caller ID	Yes by Search/Speed Dial key	N / A
<b>Call Waiting Ready</b>	<b>Yes by Search/Speed Dial key</b>	<b>Yes by Search/Speed Dial key</b>
Transfer Method	Flash	Flash
PBX Feature	N / A	N / A
Distinctive Ringing	Yes	Yes
Hold/Mute Key	Yes	Yes
Power Failure Dialing	N / A	N / A
Speaker Volume	Yes (3 steps + OFF)	Yes (3 steps + OFF)
Ring Volume	Yes (3 steps + OFF)	Yes (3 steps + OFF)
Handset Volume	Yes (2 steps + 1(Hearing Amplify) step)	Yes (2 steps + 1(Hearing Amplify) step)
Figures of One-Touch & Speed Dial	20 digits	20 digits
Resisterable Number Of Characters	15 chars	15 chars



<b>Model Name</b>	<b>FAX4750e</b>	<b>FAX5750e</b>
<b>GENERAL</b>		
Print Engine	Laser (ZLe)	Laser (ZLe)
<b>Modem Speed(bps)</b>	<b>33,600(Fax)</b>	<b>33,600(Fax)</b>
<b>Transmission Speed(sec.)</b>	<b>Approx. 2</b>	<b>Approx. 2</b>
ITU-T Group	<b>Super G3</b>	<b>Super G3</b>
<b>Coding Method</b>	<b>MH/MR/MMR/JBIG</b>	<b>MH/MR/MMR/JBIG</b>
Input/Output Width	5.8"-8.5"/2.75"-8.5"	5.8"-8.5"/2.75"-8.5"
ADF(pages)	30 (50:Conditional *1)	30 (50:Conditional *1)
LCD Size	16 Characters x 2 Lines	16 Characters x 2 Lines
On-Screen Programming	Yes	Yes
Back up Clock	Yes (9 hours)	Yes (9 hours)
Memory Capacity(MB)	8 MB	8 MB
Back up Memory	<b>Yes ( for 4 days )</b>	<b>Yes ( for 4 days )</b>
Memory Security	<b>Yes</b>	<b>Yes</b>
Optional Memory	<b>Yes(16/32 Mbyte:DIMM)</b>	<b>Yes(16/32 Mbyte:DIMM)</b>
Paper Capacity(sheets)	250	<b>500(250+250)</b>
Additional Paper Capacity(sheets)	250 (User Option)	N/A
Dimensions (WxDxH)	17.1x17.4x12.7 inches 435x442x323 mm	17.1x17.4x17.0 inches 435x442x432 mm
Weight	26.4 lbs/(12 kg)	34.3 lbs/(15.5kg)
Color	Gray 1495	Gray 1495
Standby Mode	Yes	Yes
<b>PC-Fax Protocol Compliance</b>	<b>Class 2</b>	<b>Class 2</b>
Simultaneous Operation	Yes	Yes
Data Modem	N / A	N / A
Energy Star Compliance (for U.S.A.)	Yes	Yes
LCD Back Light	N / A	N / A
Operating Environment Temperature Humidity	10 - 32.5 degrees Centigrade 20 - 80%(without condensation)	10 - 32.5 degrees Centigrade 20 - 80%(without condensation)
Power Source	120VAC 50/60Hz	120VAC 50/60Hz
Power Consumption (Sleep/Standby/Peak)	Less than 10W / 70W / 940W	Less than 10W / 70W / 940W
Toner Life (Standard Yield : TN-430) (High Yield : TN-460)	3,000 A4 pages@5% 6,000 A4 pages@5%	3,000 A4 pages@5% 6,000 A4 pages@5%
Drum Life (DR-400)	up to 20,000 pages	up to 20,000 pages
Bundled Cable	N / A	N / A
<b>TELEPHONE</b>		
Automatic Redial	Yes	Yes
Handset	Yes	Yes
One-Touch Dial	32 (16x2)	32 (16x2)
Speed Dial	<b>200 *5</b>	<b>200 *5</b>
Telephone Index	Yes	Yes
Speaker Phone	N / A	N / A
Chain Dialing	Yes	Yes
Caller ID	Yes	Yes
Call Waiting Caller ID	N / A	N / A
<b>Call Waiting Ready</b>	<b>Yes by Search/Speed Dial key</b>	<b>Yes by Search/Speed Dial key</b>
Transfer Method	Flash	Flash
PBX Feature	N / A	N / A
Distinctive Ringing	Yes	Yes
Hold/Mute Key	Yes	Yes
Power Failure Dialing	N / A	N / A
Speaker Volume	Yes (3 steps + OFF)	Yes (3 steps + OFF)
Ring Volume	Yes (3 steps + OFF)	Yes (3 steps + OFF)
Handset Volume	Yes (2 steps + 1(Hearing Amplify) step)	Yes (2 steps + 1(Hearing Amplify) step)
Figures of One-Touch & Speed Dial	20 digits	20 digits
Resisterable Number Of Characters	15 chars	15 chars

<b>Model Name</b>	<b>MFC8500</b>	<b>F AX4100</b>
<b>FAX</b>		
Internet FAX	N / A	N / A
Easy Receive/Fax Detect	Yes	Yes
Fax/Tel Switch	Yes	Yes
Super Fine	Yes (TX & RX)	Yes (TX & RX)
300dpi Transmission	N / A	N / A
Gray Scale	64	64
Contrast	Yes (Auto/S.Light/S.Dark)	Yes (Auto/S.Light/S.Dark)
Smoothing	Yes	Yes
Call Reservation Over Auto TX	N / A	N / A
Password Check	N / A	N / A
Enhanced Remote Activate	Yes	Yes
Multi Resolution Transmission	N / A	N / A
Multi Transmission	N / A	N / A
Next-Fax Reservation	Yes (Dual Access)	Yes (Dual Access)
Delayed Timer	Yes (up to 50)	Yes (up to 50)
Polling	Yes (Std/Seq)	Yes (Std/Seq)
Quick Scan (Memory Transmission)	Approx. 2 sec./page (A4:standard)	Approx. 2 sec./page (A4:standard)
Broadcasting	Yes (166 locations)	<b>Yes (182 locations)</b>
Batch Transmission	Yes	Yes
Auto Reduction	Yes	Yes
<b>Out-of-Paper Reception *2</b>	<b>up to 500 pages(MMR)</b>	<b>up to 500 pages(MMR)</b>
Dual Access	Yes	Yes
ECM(Error Correction Mode)	Yes	Yes
ITU SUB Addressing	N / A	N / A
Group Dial	Yes (6)	Yes (6)
Resend After Receive Error Signal	N / A	N / A
Confidential	N / A	N / A
Station ID	1 (20 digits/20 chars)	1 (20 digits/20 chars)
Off Hook Alarm	N / A	N / A
Remote Maintenance	Yes	Yes
Call Reservation Over Manual TX	N / A	N / A
RX Mode Indication	LED	LED
Resolution Indication	LED	LED
<b>LIST REPORT</b>		
Activity Report/Journal Report	Yes (up to 200)	Yes (up to 200)
Transmission Verification Report	Yes	Yes
Coverpage	Yes (Super)	Yes (Super)
Help List	Yes	Yes
Call Back Message	N / A	N / A
Caller ID List	Yes	Yes
<b>Demo Sheet</b>	<b>Yes by Stop/Exit &amp; Fax Start keys</b>	<b>Yes by Stop/Exit &amp; Fax Start keys</b>
<b>INTERFACE</b>		
External TAD Interface	Yes	Yes
Missing Link/PC Interface	N / A	N / A
Host Interface	<b>Yes (Auto switching : Parallel/USB *3)</b>	<b>Yes (Auto switching : Parallel/USB *3) *4</b>
LAN Interface	N / A	N / A

<b>Model Name</b>	<b>FAX4750e</b>	<b>FAX5750e</b>
<b>FAX</b>		
Internet FAX	<b>Available with Option[NC-8100h]</b>	<b>Yes</b>
Easy Receive/Fax Detect	Yes	Yes
Fax/Tel Switch	Yes	Yes
Super Fine	Yes (TX & RX)	Yes (TX & RX)
300dpi Transmission	N / A	N / A
Gray Scale	64	64
Contrast	Yes (Auto/S.Light/S.Dark)	Yes (Auto/S.Light/S.Dark)
Smoothing	Yes	Yes
Call Reservation Over Auto TX	N / A	N / A
Password Check	N / A	N / A
Enhanced Remote Activate	Yes	Yes
Multi Resolution Transmission	N / A	N / A
Multi Transmission	N / A	N / A
Next-Fax Reservation	Yes (Dual Access)	Yes (Dual Access)
Delayed Timer	Yes (up to 50)	Yes (up to 50)
Polling	Yes (Std/Seq)	Yes (Std/Seq)
Quick Scan (Memory Transmission)	Approx. 2 sec./page (A4:standard)	Approx. 2 sec./page (A4:standard)
Broadcasting	<b>Yes (282 locations)</b>	<b>Yes (282 locations)</b>
Batch Transmission	Yes	Yes
Auto Reduction	Yes	Yes
<b>Out-of-Paper Reception *2</b>	<b>up to 600 pages(JBIG)</b>	<b>up to 600 pages(JBIG)</b>
Dual Access	Yes	Yes
ECM(Error Correction Mode)	Yes	Yes
ITU SUB Addressing	N / A	N / A
Group Dial	Yes (6)	Yes (6)
Resend After Receive Error Signal	Yes	Yes
Confidential	N / A	N / A
Station ID	1 (20 digits/20 chars)	1 (20 digits/20 chars)
Off Hook Alarm	N / A	N / A
Remote Maintenance	Yes	Yes
Call Reservation Over Manual TX	N / A	N / A
RX Mode Indication	LED	LED
Resolution Indication	LED	LED
<b>LIST REPORT</b>		
Activity Report/Journal Report	Yes (up to 200)	Yes (up to 200)
Transmission Verification Report	Yes	Yes
Coverpage	Yes (Super)	Yes (Super)
Help List	Yes	Yes
Call Back Message	N / A	N / A
Caller ID List	Yes	Yes
<b>Demo Sheet</b>	N / A	N / A
<b>INTERFACE</b>	<b>Interface backside to be covered with plastic cover.</b>	<b>No cover</b>
External TAD Interface	Yes	Yes
Missing Link/PC Interface	N / A	N / A
Host Interface	<b>Yes (Auto switching : Parallel/USB *3) *4</b>	<b>Yes (Auto switching : Parallel/USB *3)</b>
LAN Interface	<b>Available with Option[NC-8100h]</b>	<b>Yes</b>

<b>Model Name</b>	<b>MFC8500</b>	<b>FAX4100</b>
<b>PRINTER</b>	<b>Yes</b>	<b>Available with Web download</b>
Color/Mono	Mono	Mono
Engine Type	Laser(ZL)	Laser(ZLe)
Resolution(dpi)	600x600	600x600
Speed(ppm)	up to 15 (Letter size)	up to 15 (Letter size)
Output Paper Capacity(sheets)	150	150
Standard Print Language	Windows GDI(600x600)	Windows GDI(600x600)
Emulation	PCL4	N / A
Resident Fonts	24 Bitmap (PCL4 Comp.)	N / A
Fonts Disk Based	Yes (35 TrueType)	N / A
Paper Handling Size	LTR, LGL, A4, B5, A5, EXE	LTR, LGL, A4, B5, A5, EXE
Manual Feed Slot	Custom Size (2.75x5 - 8.5x14) Envelop(DL/C5/CM10/Mona)	Custom Size (2.75x5 - 8.5x14) Envelop(DL/C5/CM10/Mona)
Other Paper Type	OHP, Envelopes, Labels, Organizer	OHP, Envelopes, Labels, Organizer
Sheet Weight (Paper Cassette) (Manual Slot)	64-105 g/m2 (17 - 28 lb) 64-157 g/m2 (17 - 43 lb)	64-105 g/m2 (17 - 28 lb) 64-157 g/m2 (17 - 43 lb)
Printer Driver	Win95/98(SE)/Me and NT4.0/2000 Driver with Auto Installer Program	Win95/98/Me/NT4.0/2000/XP Driver with Auto Installer Program
<b>Utility Software</b>	<b>Yes (Remote Printer Console for PCL4 )</b>	<b>N / A</b>
<b>COPY</b>		
Color	N / A	N / A
Speed(cpm)	up to 15 (Letter size)	up to 15 (Letter size)
Multi Copy(Stack)	up to 99	up to 99
Multi Copy(Sort)	Yes	Yes
Reduction/Enlargement(%)	50 -- 200 in 1% increments	50 -- 200 in 1% increments
Resolution(dpi)	600 dpi class	600 dpi class
<b>SCANNER</b>	<b>Yes</b>	<b>N / A</b>
Color/Mono	Mono	N / A
Resolution(dpi)	9,600x9,600(Int.)/300x600(Opt.)	N / A
Gray Scale	256	N / A
TWAIN Compliant	Yes	N / A
OCR	Yes(ScanSoft TextBridge)	N / A
<b>MESSAGE CENTER/MESSAGE MANAGE</b>	<b>N / A</b>	<b>N / A</b>
ICM Recording Time	N / A	N / A
Page Memory	N / A	N / A
OGM (MC/MC Pro/Paging)	N / A	N / A
TAD Type	N / A	N / A
Memo/Recording Conversation	N / A	N / A
Toll Saver	N / A	N / A
Fax Forwarding	Yes	Yes
Fax Retrieval	Yes	Yes
Paging	Yes	Yes
Remote Access	Yes	Yes

<b>Model Name</b>	<b>FAX4750e</b>	<b>FAX5750e</b>
<b>PRINTER</b>	<b>Available with Web download</b>	<b>Yes - standard</b>
Color/Mono	Mono	Mono
Engine Type	Laser(ZLe)	Laser(ZLe)
Resolution(dpi)	600x600	600x600
Speed(ppm)	up to 15(Letter size)	up to 15(Letter size)
Output Paper Capacity(sheets)	150	150
Standard Print Language	Windows GDI(600x600)	Windows GDI(600x600)
Emulation	N / A	<b>PCL5e</b>
Resident Fonts	N / A	N / A
Fonts Disk Based	N / A	N / A
Paper Handling Size	LTR, LGL, A4, B5, A5, EXE	LTR, LGL, A4, B5, A5, EXE
Manual Feed Slot	Custom Size (2.75x5 - 8.5x14) Envelop(DL/C5/CM10/Mona)	Custom Size (2.75x5 - 8.5x14) Envelop(DL/C5/CM10/Mona)
Other Paper Type	OHP, Envelopes, Labels, Organizer	OHP, Envelopes, Labels, Organizer
Sheet Weight (Paper Cassette) (Manual Slot)	64-105 g/m2 (17 - 28 lb) 64-157 g/m2 (17 - 43 lb)	64-105 g/m2 (17 - 28 lb) 64-157 g/m2 (17 - 43 lb)
Printer Driver	Win95/98/Me//NT4.0/2000/XP Driver with Auto Installer Program	Win95/98/Me//NT4.0/2000/XP Driver with Auto Installer Program
<b>Utility Software</b>	N / A	<b>Yes (Remote Printer Console for PCL5e )</b>
<b>COPY</b>		
Color	N / A	N / A
Speed(cpm)	up to 15 (Letter size)	up to 15 (Letter size)
Multi Copy(Stack)	up to 99	up to 99
Multi Copy(Sort)	Yes	Yes
Reduction/Enlargement(%)	50 -- 200 in 1% increments	50 -- 200 in 1% increments
Resolution(dpi)	600 dpi class	600 dpi class
<b>SCANNER</b>	<b>Available with web download</b>	<b>Yes - standard</b>
Color/Mono	Mono	Mono
Resolution(dpi)	9,600x9,600(Int.)/300x600(Opt.)	9,600x9,600(Int.)/300x600(Opt.)
Gray Scale	256	256
TWAIN Compliant	Yes	Yes
OCR	Yes (ScanSoft TextBridge)	Yes (ScanSoft TextBridge)
<b>MESSAGE CENTER/MESSAGE MANAGE</b>	<b>N / A</b>	<b>N / A</b>
ICM Recording Time	N / A	N / A
Page Memory	N / A	N / A
OGM (MC/MC Pro/Paging)	N / A	N / A
TAD Type	N / A	N / A
Memo/Recording Conversation	N / A	N / A
Toll Saver	N / A	N / A
Fax Forwarding	Yes	Yes
Fax Retrieval	Yes	Yes
Paging	Yes	Yes
Remote Access	Yes	Yes

<b>Model Name</b>	<b>MFC8500</b>	<b>F AX4100</b>
<b>APPLICATION SOFTWARE</b>		
<b>For Windows</b>		
<b>Printer Driver (Brother)</b>	Yes	<b>Downloadable from the web site</b>
TWAIN (Brother)	Yes	N / A
POP UP menu	Yes	N / A
PC Fax (Brother; both TX & RX )	Yes	N / A
Remote Setup	Yes	N / A
Auto Email Printing	Yes	N / A
Support OS version (Win95/98(SE)/Me, WinNT4.0/2K/XP)	Yes	N / A
BRAdmin Professional	Yes	N / A
Network Print Software (LRP) for Win95/98(SE)/Me/XP)	Yes	N / A
Network Print Software (NetBIOS/SMTP)	Yes	N / A
<b>For iMAC</b>		
<b>Printer Driver (Brother)</b>	Yes	<b>Downloadable from the web site</b>
TWAIN (TII/Brother)	Yes	N / A
Viewer (ScanSoft PaperPort)	Yes	N / A
POP UP menu	Yes	N / A
PC Fax (Brother)	Yes	N / A
Remote Setup	Yes	N / A
Auto Email Printing	Yes	N / A
Support OS version Printer 8.5 - 9.1	Yes	N / A
Others 8.6 - 9.2	Yes	N / A

\*1: Xerox 4200 20lb paper under Office Condition (Temperature/Humidity)

\*2: Brother Chart #1 with JBIG Coding System and Standard Resolution

\*3: USB - Windows98/Me/2000/XP and iBook/iMAC/G3/G4 only.

\*4: The interface connector is covered with a plastic plate.

\*5: Email address can be stored up to 100 locations; from 01 -100.

<b>Model Name</b>	<b>FAX4750e</b>	<b>FAX5750e</b>
<b>APPLICATION SOFTWARE</b>		
<b>For Windows</b>		
<b>Printer Driver (Brother)</b>	Downloadable from the web site	Yes - standard
TWAIN (Brother)	Downloadable from the web site	Yes - standard
POP UP menu	Downloadable from the web site	Yes - standard
PC Fax (Brother; both TX & RX )	Downloadable from the web site	Yes - standard
Remote Setup	Downloadable from the web site	Yes - standard
Auto Email Printing	N / A	N / A
Support OS version (Win95/98(SE)/Me, WinNT4.0/2K/XP)	Downloadable from the web site	Yes - standard
BRAdmin Professional	Downloadable from the web site	Yes - standard
Network Print Software (LRP) for Win95/98(SE)/Me/XP)	Downloadable from the web site	Yes - standard
Network Print Software (NetBIOS/SMTTP)	Downloadable from the web site	Yes - standard
<b>For iMAC</b>		
<b>Printer Driver (Brother)</b>	Downloadable from the web site	Yes - standard
TWAIN (TII/Brother)	Downloadable from the web site	Yes - standard
Viewer (ScanSoft PaperPort)	Downloadable from the web site	Yes - standard
POP UP menu	Downloadable from the web site	Yes - standard
PC Fax (Brother)	Downloadable from the web site	Yes - standard
Remote Setup	Downloadable from the web site	Yes - standard
Auto Email Printing	N / A	N / A
Support OS version Printer 8.5 - 9.1	Downloadable from the web site	Yes - standard
Others 8.6 - 9.2	Downloadable from the web site	Yes - standard

- \*1: Xerox 4200 20lb paper under Office Condition (Temperature/Humidity)
- \*2: Brother Chart #1 with JBIG Coding System and Standard Resolution
- \*3: USB - Windows98/Me/2000/XP and iBook/iMAC/G3/G4 only.
- \*4: The interface connector is covered with a plastic plate.
- \*5: Email address can be stored up to 100 locations; from 01 -100.

<b>Model Name</b>	<b>MFC-9660</b>	<b>FAX8360P</b>
<b>GENERAL</b>		
Print Engine	Laser (ZLe)	Laser (ZLe)
Modem Speed(bps)	33,600(Fax)	33,600(Fax)
Transmission Speed(sec.)	Approx.2 ( Brother#1, JBIG )	Approx.2 ( Brother#1, JBIG )
ITU-T Group	Super G3	Super G3
Coding Method	MH/MR/MMR/JBIG	MH/MR/MMR/JBIG
Input/Output Width	5.8"-8.5"/2.75"-8.5"	5.8"-8.5"/2.75"-8.5"
ADF(pages)	Up to 30	Up to 30
LCD Size	16 Characters x 2 Lines	16 Characters x 2 Lines
On-Screen Programming	Yes	Yes
Back up Clock	Yes (9 hours)	Yes (9 hours)
Memory Capacity (Physical: MByte)	8 Mbyte(RAM)	8 Mbyte(RAM)
Memory Backup	Yes( Max 4 days)	Yes( Max 4 days)
Optional Memory	Yes( 16/32 MByte:DIMM)	Yes( 16/32 MByte:DIMM)
Optional Paper Tray	Yes(250pages:LT-400)	Yes(250pages:LT-400)
Dimensions w/carton (WxDxH)	471 x 560 x 460 mm	471 x 560 x 460 mm
Dimensions w/out carton (WxDxH)	377 x 442 x 323 mm	377 x 442 x 323 mm
Weight w/carton	16.5 Kg	16.5 Kg
Weight w/out carton	12 Kg	12 Kg
Color	Gray 1495	Gray 1495
Standby Mode	Yes	Yes
PC-Fax Protocol Compliance(TX/RX)	Class 2	-
Simultaneous Operation	Yes ( Print/Fax, Print/Copy, Print/Scan )	N/A
Data Modem	N/A	N/A
Energy Star Compliance	N/A	N/A
Operating Environment Temperature Humidity	10 - 32.5 degrees Centigrade 20 - 80%(without condensation)	10 - 32.5 degrees Centigrade 20 - 80%(without condensation)
Power Source	220-240VAC 50/60Hz	220-240VAC 50/60Hz
Power Consumption(Sleep/Standby/Peak)	10W / 70W / 940W or less	10W / 70W / 940W or less
Demo Model	No	No
<b>TELEPHONE</b>		
Automatic Redial	Yes	Yes
Handset	No	No
One-Touch Dial	32 (16x2) locations	32 (16x2) locations
Speed Dial	100	200
Telephone Index	Yes ( Normal )	Yes ( Normal )
Speaker Phone	N/A	N/A
Chain Dialing	Yes	Yes
Caller ID	N/A	N/A
Call Waiting Caller ID	N/A	N/A
Distinctive Ringing	Yes(UK, DEN Only)	Yes(UK, DEN Only)
Hold/Mute Key	N/A	N/A
Power Failure Dialing	N/A	N/A
Speaker Volume	Yes (3 steps + OFF)	Yes (3 steps + OFF)
Ring Volume	Yes (3 steps + OFF)	Yes (3 steps + OFF)
Handset Volume	N/A	N/A
PBX Feature	Yes	Yes
Transfer Method	Flash	Flash
Figures of One-touch & Speed Dial	20 digits	20 digits
Resisterable Number of Characters	15 characters	15 characters



<b>Model Name</b>	<b>MFC-9660</b>	<b>FAX8360P</b>
<b>FAX</b>		
Internet FAX	Available with Option ( NC8100h )	-
Easy Receive/Fax Detect	Yes	Yes
Fax/Tel Switch	Yes	Yes
Super Fine	Yes (TX & RX)	Yes (TX & RX)
300dpi Transmission	No	No
Gray Scale	64	64
Contrast	Yes (Auto/Light/Dark)	Yes (Auto/Light/Dark)
Smoothing	Yes	Yes
Call Reservation Over Auto TX	No	No
Password Check	No	No
Enhanced Remote Activate	Yes	Yes
Multi Resolution Transmission	No	No
Multi Transmission (>Dual Access )	No	No
Next-Fax Reservation (>Dual Access)	No	No
Delayed Timer	Yes (up to 50 locations )	Yes (up to 50 locations )
Polling	Yes (Std/Seq/Sec/Del)	Yes (Std/Seq/Sec/Del)
Quick Scan (Memory Transmission)	Yes as default, approx. 2 sec./page (A4 :standard)	Yes as default, approx. 2 sec./page (A4 :standard)
Broadcasting	Yes (182 locations)	Yes (282 locations)
Batch Transmission	Yes	Yes
Auto Reduction	Yes	Yes
Out-of-Paper Reception (ITU-T#1 Chart) *1	Up to 500 pages ( JBIG/Standard Resolution )	Up to 500 pages ( JBIG/Standard Resolution )
Dual Access	Yes	Yes
ECM(Error Correction Mode)	Yes	Yes
ITU SUB Addressing	No	-
Resend After Receive Error Signal	Yes	Yes
Confidential	No	No
Station ID	1 (20digits/20char)	1 (20digits/20char)
Off Hook Alarm	No	No
Remote Maintenance	Yes	Yes
Call Reservation Over Manual TX	No	No
RX Mode Indication	LED	LED
Resolution Indication	LED	LED
<b>LIST REPORT</b>		
Activity Report/Journal Report	Yes (up to 200)	Yes (up to 200)
Transmission Verification Report	Yes	Yes
Coverpage	Yes (Super)	Yes (Super)
Help List	Yes( Reports key )	Yes( Reports key )
Call Back Message	No	No
Caller ID List	No	No
<b>INTERFACE</b>		
External TAD Interface	Yes	-
Missing Link/PC Interface(=Serial I/F)	No	-
Host Interface(Serial)	No	-
Host Interface(IEEE1284)	Yes	-
Host Interface(USB)	Yes	-
LAN Interface	Ethernet Auto Switching 10/100 Base-TX Available With Optional NC-8100h	-

<b>Model Name</b>	<b>MFC-9660</b>	<b>FAX8360P</b>
<b>PRINTER</b>		
Color/Mono	Mono	-
Engine Type	Laser(ZLe)	-
Resolution(dpi)	600x600	-
Speed(ppm)	up to 14	-
Paper Capacity(sheets)	250	-
Additional Paper Capacity(sheets)	250 (User Option)	-
Output Paper Capacity(sheets)	150	-
Standard Print Language	Windows GDI(600x600)	-
Emulation	PCL5e	-
Resident Fonts	Yes (Bitmap font:Letter Gothic 16.66, OCR-A, OCR-B, Scaleable font; 49 fonts )	-
Fonts Disk Based	Yes (49 TrueType)	-
Paper Handling Size	LTR, EXE, A4, A5, A6, ISO B5, ISO B6	-
Manual Feed Slot	Custom Size (2.75x5 - 8.5x14) Envelop(DL/C5/CM10/Mona)	-
Other Paper Type	OHP, Envelopes, Labels, Organizer	-
Sheet Weight (Paper Cassette) (ADF) (Manual Slot)	60-105 g/m2 64 - 90 g/m2 60-161 g/m2	-
Printer Driver	Win95/98(SE)/Me and NT4.0/2000 MacOS 8.5-9.1	-
Utility Software	Yes (Remote Printer Console for PCL5e)	-
Toner Life (Standard Yield : TN-6300) (High Yield : TN-6600)	Up to 3,000 A4 pages@5% Up to 6,000 A4 pages@5%	-
Drum Life (DR-6000)	Up to 20,000 pages ( by Continuous printing )	-
Interface Type	Parallel & USB *2	-
Bundled Cable	No	-
<b>COPY</b>		
Speed(cpm)	Up to 14	Up to 14
Multi Copy(Stack)	Yes ( Up to 99 )	Yes ( Up to 99 )
Multi Copy(Sort)	Yes	Yes
Poster	No	No
Reduction/Enlargement(%)	50 -- 200 in 1% increments	50 -- 200 in 1% increments
Resolution(dpi)	600x300	600x300
<b>SCANNER</b>		
Colour/Mono	Mono	-
Resolution(dpi) Optical	300x600	-
Resolution(dpi) Interpolated	9,600x9,600	-
Colour Depth	No	-
Gray Scale	256	-
TWAIN Compliant & Operating System	Win95/98/98SE/Me MacOS 8.6-9.1	-
Scan to Image key	Yes	-
Scan to OCR key	Yes	-
Scan to E-mail key	Yes	-

<b>Model Name</b>	<b>MFC-9660</b>	<b>FAX8360P</b>
<b>MESSAGE CENTER/MESSAGE MANAGER</b>		
ICM Recording Time	N / A	N / A
Page Memory	N / A	N / A
OGM (MC/MC Pro/Paging)	N / A	N / A
TAD Type	N / A	N / A
Memo/Recording Conversation	N / A	N / A
Toll Saver	N / A	N / A
Fax Forwarding	Yes	Yes
Fax Retrieval	Yes	Yes
Paging	No	No
Remote Access	Yes	Yes
<b>MESSAGE CENTER Pro/MESSAGE MANAGER</b>	<b>N/A</b>	<b>N/A</b>
<b>MESSAGE CENTER (PC MC)</b>	<b>N/A</b>	<b>N/A</b>
<b>VIDEO CAPTURE</b>	<b>N/A</b>	<b>N/A</b>
<b>PHOTO CAPTURE CENTER</b>	<b>N/A</b>	<b>N/A</b>
<b>BUNDLED SOFTWARE</b>		
For Windows		
Support OS version	Win95/98/98SE/Me, WinNT4.0/2K	-
Printer Driver	Yes(Brother )	-
Viewer	Yes ( PaperPort by ScanSoft including Text Bridge OCR)	-
TWAIN	Yes(Brother )	-
PC Fax	Yes ( Brother: both TX & RX )	-
For MAC		
Support OS version    Printer	Mac OS 8.5 - 9.1	-
Others	Mac OS 8.6 - 9.1	-
Printer Driver	Yes(Brother )	-
Viewer	No	-
TWAIN	Yes(Brother )	-
PC Fax	Yes(Brother; TX only)	-

\*1: Brother Chart #1 with JBIG Coding System and Standard Resolution

\*2: The interface connector is covered with a plastic plate.

# **CHAPTER II.**

# **INSTALLATION**

## **CHAPTER 2 INSTALLATION**

### **CONTENTS**

1. **INSTALLING THE UPDATE DATA TO THE FACSIMILE MACHINE..... II-1**
2. **SETTING ID CODES TO FACSIMILE MACHINES..... II-3**

# 1. INSTALLING THE UPDATE DATA TO THE FACSIMILE MACHINE

If you want to update the current program stored in the flash ROM of the main PCB to the newer version or after you replace the main PCB, install the update program onto the flash ROM.

**The program installation requires a PC/AT-compatible computer (which is capable of running MS-DOS or its compatible OS).**

## Connecting the facsimile machine to your computer

- (1) Make sure that your computer is turned off.
- (2) Make sure that the machine's power cord is unplugged from a wall socket. (If the machine has a power ON/OFF switch, make sure that the switch is turned off.)
- (3) Connect the parallel interface cable to the parallel port on the back of the machine and secure it with the lock wires.
- (4) Connect the other end of the interface cable to the printer port of your computer and secure it with the two screws.
- (5) While pressing the **5** key on the machine's control panel, plug the machine's power cord into a wall socket (or turn on the power ON/OFF switch if the machine has the switch).
- (6) Check to see that the following pattern displays on the LCD. If it does not display, go back to step (2) above.



- (7) Turn on your computer.

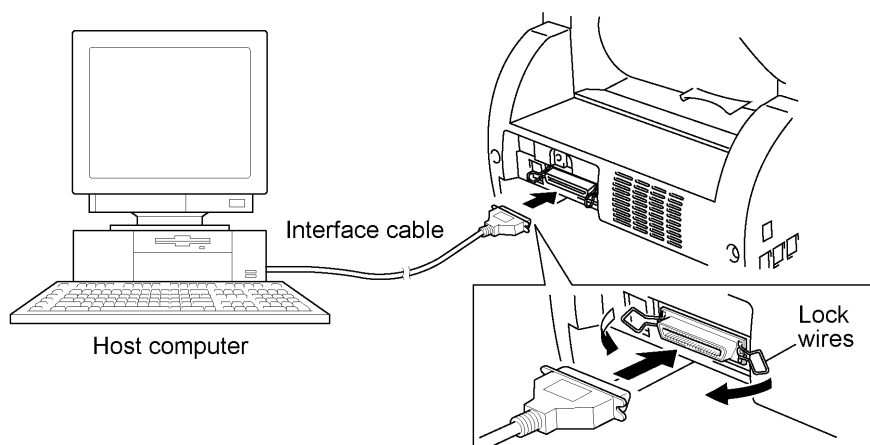

## Installing the update data onto the flash ROM of the facsimile machine

**NOTE:** The following is an installation procedure example on a PC that is running Windows 95/98.

- (1) Copy the update data and transfer utility onto the desired directory of the hard disk.  
e.g., C:\UPDATE
- (2) Click the Start button, point to Programs, and then click MS-DOS Prompt to open an MS-DOS window.
- (3) Type the drive letter where the update data and transfer utility are located. In the above example, type C:\ from the command line and press the **ENTER** key.

Then type CD UPDATE and press the **ENTER** key.

- (4) Check that your computer is connected with the facsimile machine correctly.
- (5) To start the transfer utility transmitting the update data to the flash ROM of the facsimile machine, type the following:

```
ICEN filename /b
```

Where *filename* is an update data file, e.g., 8500x.upd.

Then press the **ENTER** key.

During downloading, the machine beeps *intermittently*.

Upon completion of the downloading, the machine beeps *continuously*.

**NOTE:** If the facsimile machine cannot return to the standby state after completion of downloading, turn the power off and on.

## 2. SETTING ID CODES TO FACSIMILE MACHINES

Brother facsimile machines are assigned unique ID codes (character strings) at the factory. If you replace the main PCB of the machine, the machine will lose its assigned ID code so that it will not be identified by the connected PC\*.

You need to assign a unique ID code (character string) to the machine according to the procedure given here. For models covered by this manual, set serial numbers given to individual machines as ID codes.

(\*ID codes are essential when more than one machine is connected to a single PC via USB.)

### Connecting the facsimile machine to your PC (See the illustration on page II-1.)

- (1) Make sure that your PC is turned off.
- (2) Make sure that the machine's power cord is unplugged from a wall socket or other power source.
- (3) Connect the interface cable to the parallel interface port on the back of the facsimile machine and secure it with the lock wires.
- (4) Connect the other end of the interface cable to the printer port of your PC and secure it with the two screws.
- (5) Plug the machine's power cord into a wall socket or other power source.
- (6) Turn on your PC.

### Operating procedure

- (1) On your PC, run the ID setting utility. Follow the instructions shown on the PC's screen and enter the 9-digit serial number (e.g., G01012345) printed on the nameplate labeled to the back of the facsimile machine as an ID code. Then press the Enter key.

The ID setting utility will transmit the ID code data from your PC to the facsimile machine and then it will terminate.

The facsimile machine will automatically return to the standby mode.

- (2) To check whether the entered character string (ID code) is correct, make the machine enter the maintenance mode (refer to CHAPTER V, Section 1) and then press the **1** key twice (Subsection 3.5).

The facsimile machine will print out a Configuration List. At the right top of the list, "SER.#: BROXXXXXXXXXX" is printed.

- (3) Check that the character string entered in step (2) is printed in "XXXXXXXXXX."

If it is OK, press the **9** key twice to exit from the maintenance mode.

If something other than that is printed in XXXXXXXXXXXX, check the connection between the PC and facsimile machine and go back to step (1).



# **CHAPTER III.**

## **THEORY OF OPERATION**

## CHAPTER III. THEORY OF OPERATION

### CONTENTS

<b>1. OVERVIEW .....</b>	<b>III-1</b>
<b>2. MECHANISMS .....</b>	<b>III-2</b>
2.1 Scanner Mechanism.....	III-3
2.1.1 Document feeding and ejecting mechanism.....	III-3
2.1.2 Scanner.....	III-3
2.2 Laser Printing Mechanism.....	III-4
2.2.1 Paper pick-up and registration mechanism .....	III-4
2.2.2 Print process mechanism.....	III-5
(1) Charging process.....	III-6
(2) Exposing process.....	III-6
(3) Developing process .....	III-7
(4) Transferring process.....	III-7
2.2.3 Heat-fixing mechanism .....	III-8
2.2.4 Paper ejecting mechanism.....	III-9
2.3 Sensors and Actuators.....	III-10
<b>3. CONTROL ELECTRONICS.....</b>	<b>III-12</b>

# 1. OVERVIEW

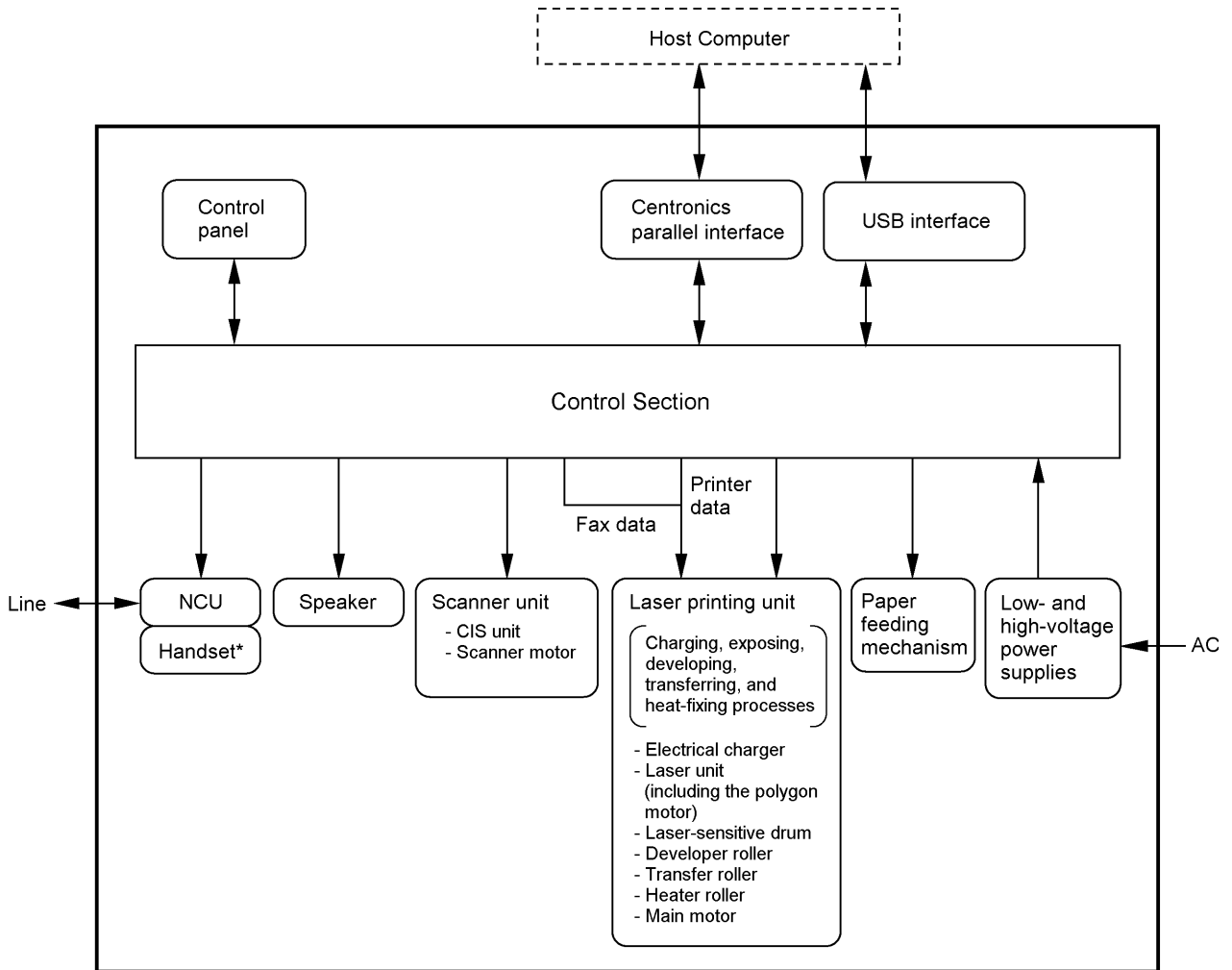

\*Not provided on those models without handset.

## 2. MECHANISMS

The facsimile equipment is classified into the following mechanisms:

- SCANNER MECHANISM
  - Document feeding and ejecting mechanism
  - Document scanning mechanism
  
- LASER PRINTING MECHANISM
  - Paper pick-up and registration mechanism
  - Print process mechanism (consisting of charging, exposing, developing, and transferring processes) with paper feeding mechanism
  - Heat-fixing mechanism with paper feeding mechanism
  - Paper ejecting mechanism
  
- SENSORS AND ACTUATORS

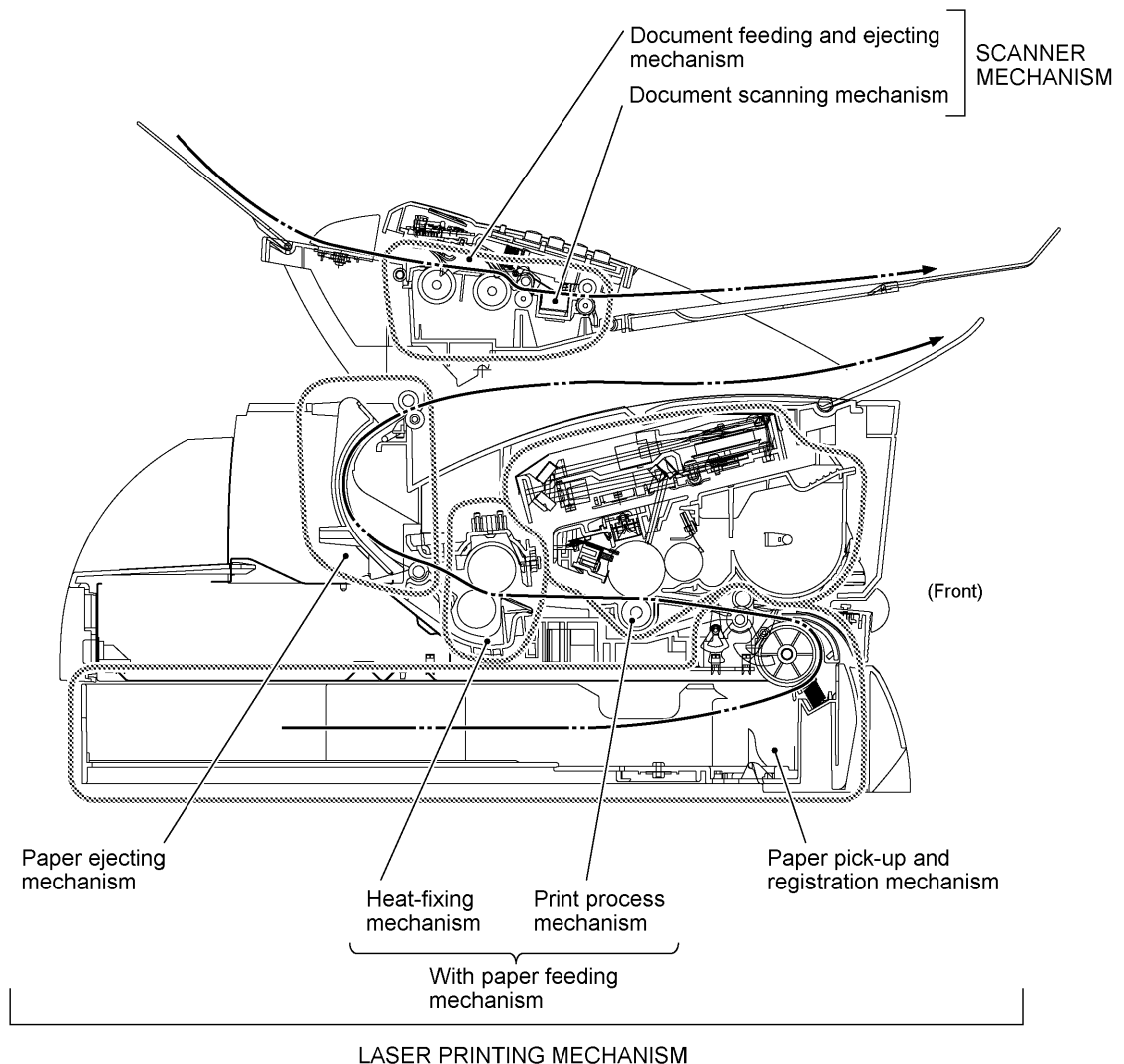

## 2.1 Scanner Mechanism

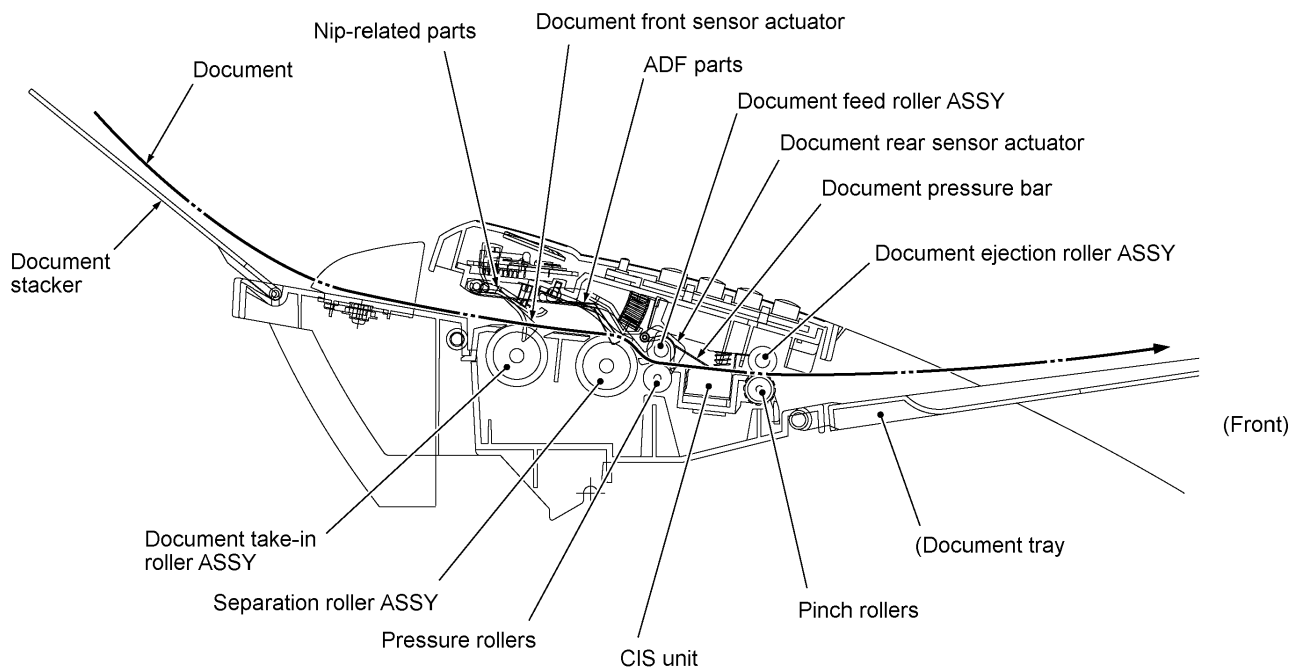

### 2.1.1 Document feeding and ejecting mechanism

This mechanism consists of the document stacker, automatic document feeder (ADF), document ejection roller ASSY, and document sensors. (For details about the sensors, refer to Section 2.3.)

If you set documents on the document stacker with their faces down and start scanning operation, then the scanner motor rotates so that the ADF (which consists of the document take-in roller ASSY, nip-related parts, separation roller ASSY, and ADF parts) feeds those documents into the equipment, starting from the bottom sheet (first page) to the top (last page), page by page. Each document advances with the document feed roller ASSY to the scanner, and then it is fed out of the equipment with the document ejection roller ASSY.

### 2.1.2 Scanner

The scanner uses a contact image sensor (CIS) unit which consists of an LED array illuminating documents, a self-focus lens array collecting the reflected light, a CIS PCB carrying out photoelectric conversion to output picture element data, and a cover glass on which a document advances. When the document passes between the document pressure bar and the cover glass, it is scanned.

## 2.2 Laser Printing Mechanism

### 2.2.1 Paper pick-up and registration mechanism

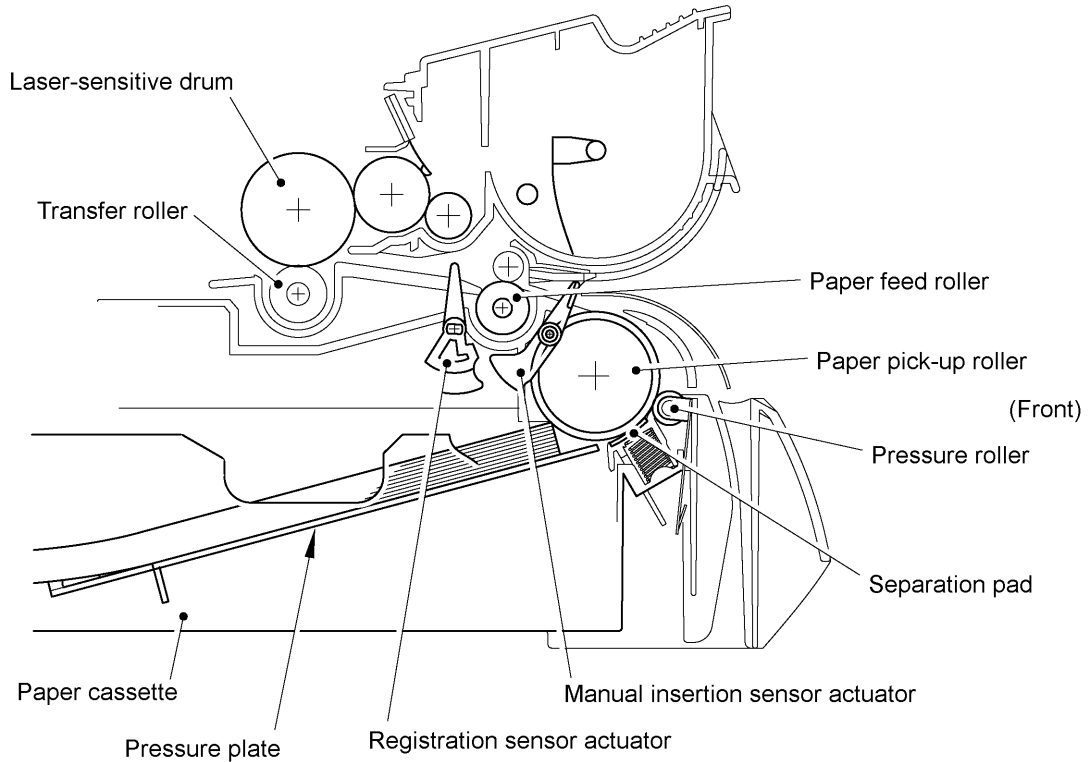

At the 1st stage, the controller drives the main motor without energizing the solenoid so that the paper feed roller simply idles.

At the 2nd stage, the controller energizes the solenoid so that the paper feed roller no longer rotates and the paper pick-up roller starts rotating to pick up paper into the equipment, a sheet at a time. After the leading edge of the pulled-in paper passes through the manual insertion sensor actuator, the paper is further fed for the specified time length. Accordingly, the leading edge will reach the paper feed roller where the paper skew will be eliminated.

At the 3rd stage, the controller deenergizes the solenoid to rotate the paper feed roller for feeding paper to the transfer block in the drum unit.

When the leading and trailing edges of the paper pass through the registration sensor actuator, the sensor signals them to the controller. According to those signals, the controller may determine the first print position on the paper.

2.2.2 Print process mechanism

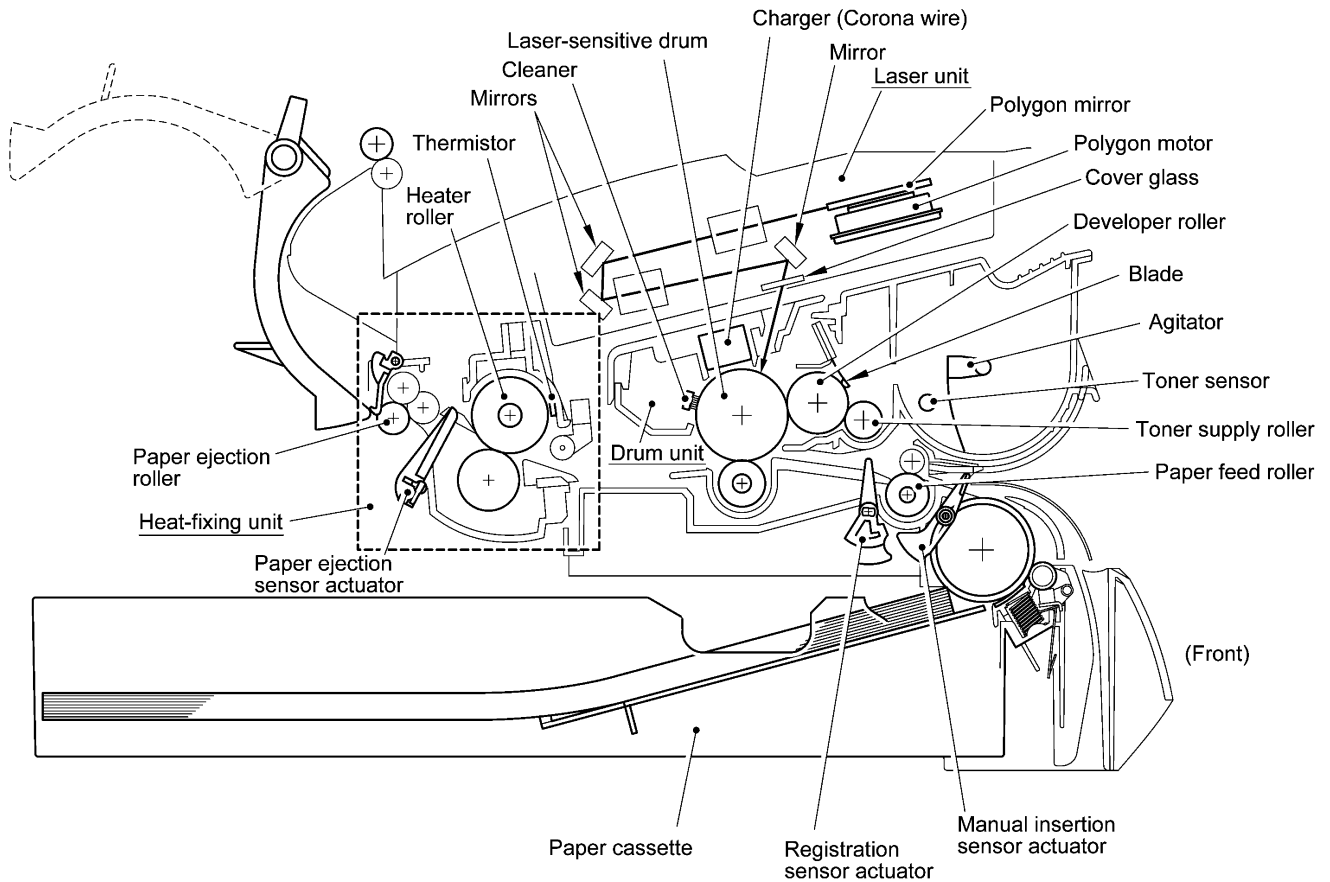

The print process unit works with laser beam, electrical charges, and toner. The graph below shows the transition of electrical charge on the surface of the laser-sensitive drum through the four processes: charging, exposing, and transferring processes.

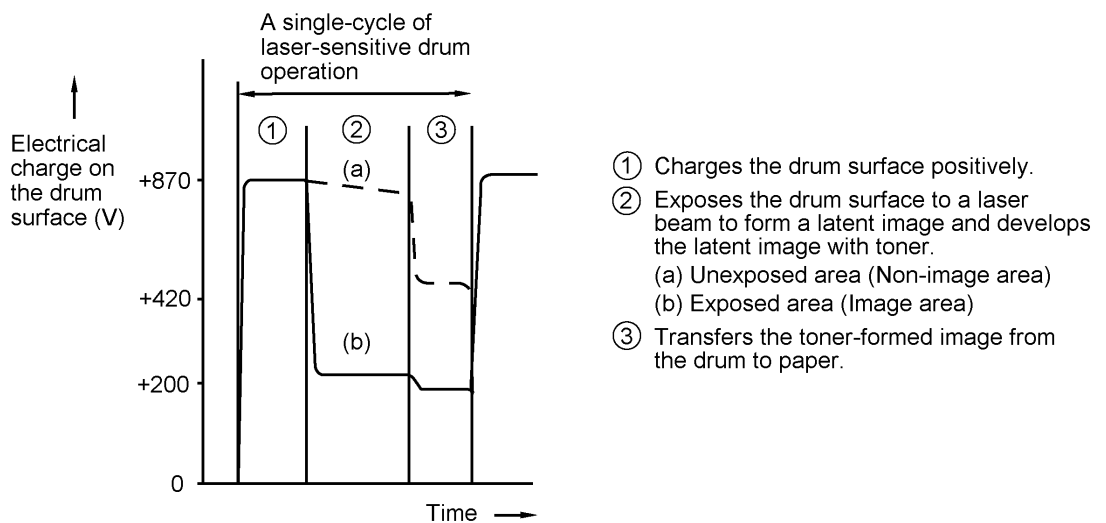

**(1) Charging process**

The high-voltage power supply applies DC bias to the corona wire to generate ion on the grid. The ion uniformly charges the surface of the laser-sensitive drum to approx. 870V which is kept by the voltage regulator grounding the grid to the frame.

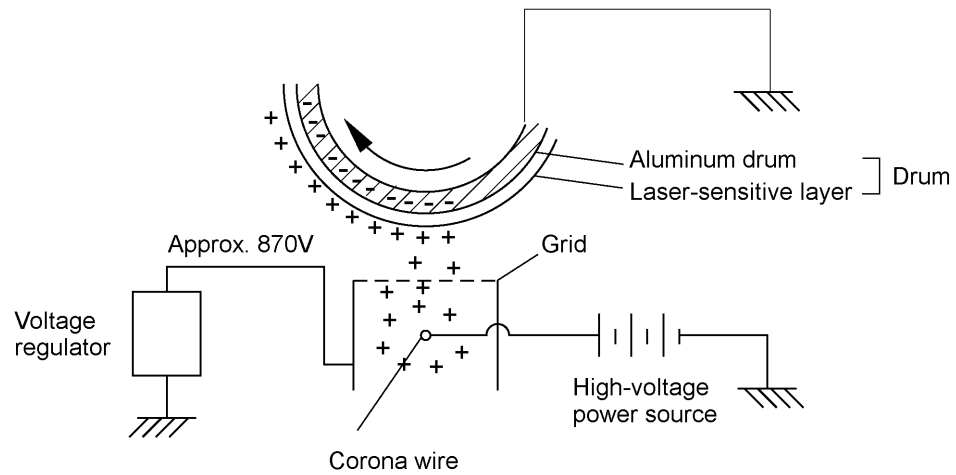

**(2) Exposing process**

When the laser-sensitive drum holds a positive electrical charge, the laser beam issued from the laser unit scans the drum according to the print image to expose the drum surface for neutralizing the spots where black should be, forming an electrostatic latent image.

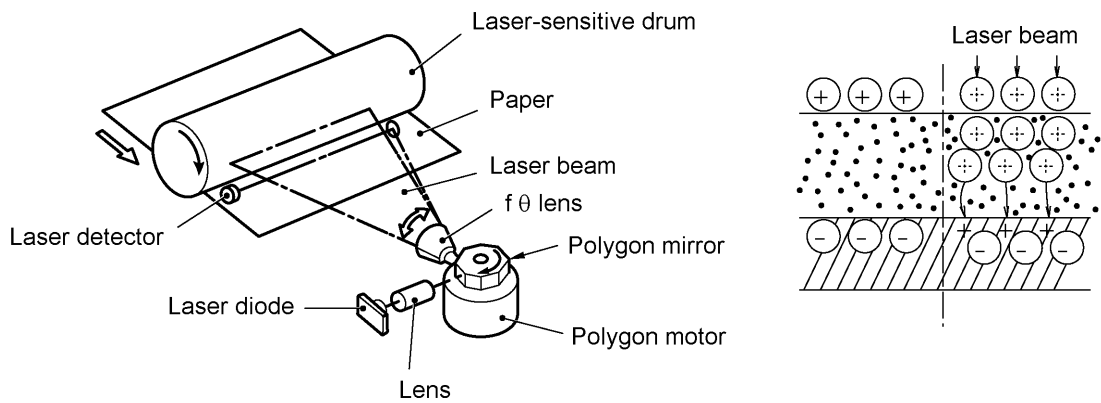



**(3) Developing process**

The developing process develops an electrostatic latent image formed on the drum in the exposing process, into a toner image.

The developer roller attracts the toner particles fed from the toner cartridge by the toner supply roller, and then conveys them to the contact section with the laser-sensitive drum

On the contact section between the developer roller and drum, the positive toner particles stick to the neutralized spots on the drum according to the principles of attraction and repulsion, transforming a latent image into a toner image.

The agitator (which agitate toner particles in the chamber) and the blade allow toner particles to be fed onto the developer roller at an even thickness.

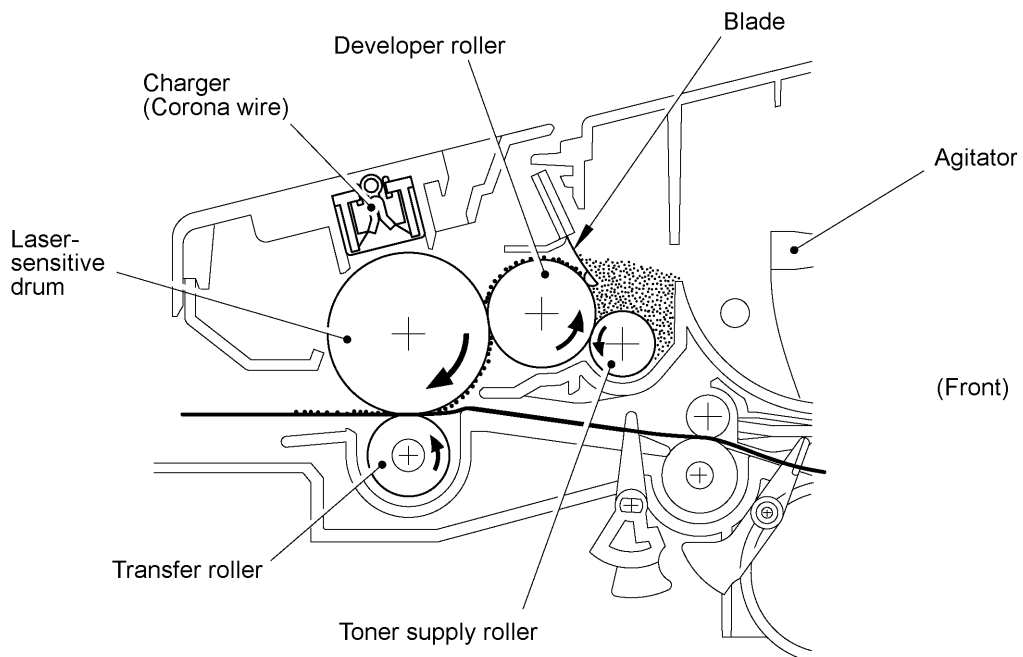

**(4) Transferring process**

When a paper passes between the drum and the transfer roller, the controller negatively charges the transfer roller. The toner is positive, so the toner image formed on the drum will be transferred onto the paper according to the same principle as for the developing process.

Cleaning the transfer roller

In the transferring process, the transfer roller may be contaminated with toner since not all the toner particles on the drum are transferred onto the paper but some toner particles will remain on the drum and will be transferred from the drum to the transfer roller. If paper jam or other errors occur, the toner image fails to stick to the paper and will stick to the transfer roller.

To repulse this toner, the controller positively charges the transfer roller. The toner returns from the transfer roller to the drum. During non-printing rotation of the drum, the toner particles on the drum will be returned to the chamber through the developer roller.

2.2.3 Heat-fixing mechanism

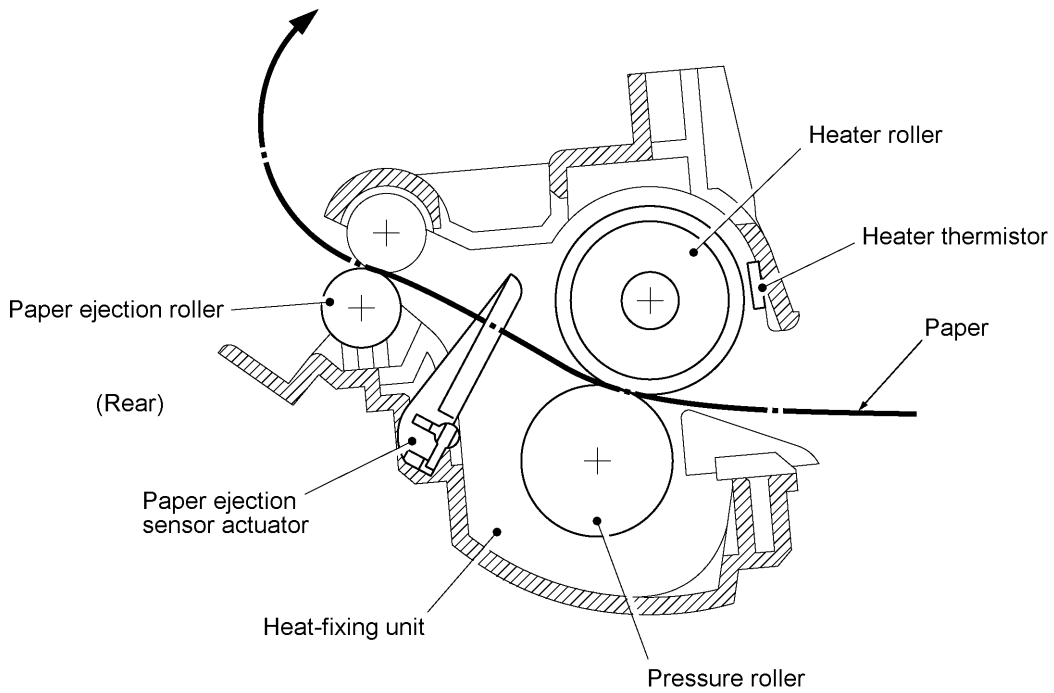

As the paper passes between the heater roller and the pressure roller in the heat-fixing unit, the heater roller fuses the toner on the paper.

The controller monitors the internal resistance of the heater thermistor to keep the surface temperature of the heater roller constant by turning the halogen heater lamp on and off.

2.2.4 Paper ejecting mechanism

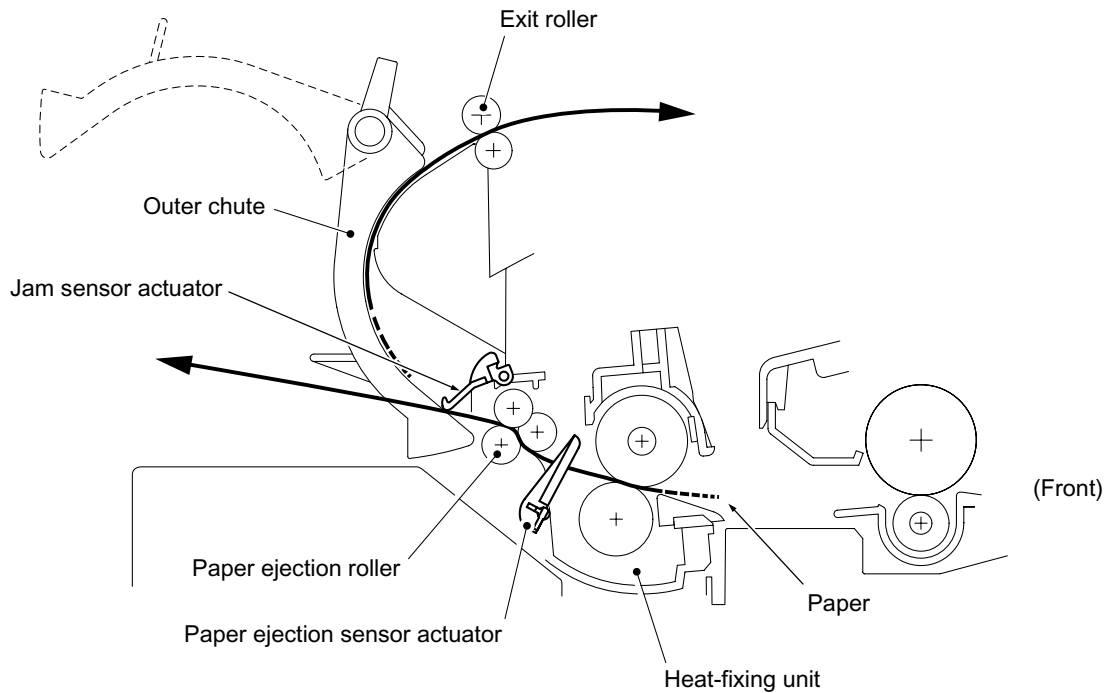

After the paper passes through the heat-fixing process, it will be ejected from the heat-fixing unit by the paper ejection roller.

If the leading edge of the paper pushes up the actuator of the paper ejection sensor, the sensor signals the start of paper ejection. If the trailing edge has passed through the sensor actuator, the sensor signals the completion of paper ejection.

If the jam sensor actuator will not be pushed up within the specified period after the leading edge of the paper pushes down the paper ejection sensor actuator, then the controller will interpret such an event as a paper jam inside the heat-fixing unit and display a jam error on the LCD.

The paper will be turned over along the outer chute and ejected onto the main cover by the exit roller.

### 2.3 Sensors and Actuators

This machine has 12 sensors: nine photosensors, two thermistors and a mechanical switch as described below.

Sensor name	Type	Located on
Document front sensor	Photosensor	Control panel PCB
Document rear sensor	Photosensor	Document sensor PCB
Manual insertion sensor	Photosensor	Engine PCB
Registration sensor	Photosensor	Engine PCB
Cassette sensor	Photosensor	Engine PCB
Paper ejection sensor	Photosensor	Paper ejection sensor PCB
Toner sensor	Photosensor	Toner sensor (LED) PCB and toner sensor (light-receiver) PCB
Cover sensor	Photosensor	Toner sensor (LED) PCB
Jam sensor	Photosensor	Heat-fixing unit
Heater thermistor	Thermistor	Heat-fixing unit
In-casing temperature sensor	Thermistor	Left-hand plate of the main chassis
Hook switch*	Mechanical switch	Hook switch PCB*

\*For models equipped with a handset

- Document front sensor which detects the presence of documents.
- Document rear sensor which detects the leading and trailing edges of pages to tell the control circuitry when the leading edge of a new page has reached the starting position and when the scan for that page is over.
- Manual insertion sensor which detects whether paper is inserted manually through the paper slot or whether paper fed through the paper cassette has jammed.
- Registration sensor which detects the leading and trailing edges of recording paper, which allows the controller to determine the registration timing and check paper jam.
- Cassette sensor which detects whether the paper cassette is loaded.
- Paper ejection sensor which detects whether the recording paper goes out of the equipment.
- Toner sensor which detects whether there is toner or a toner cartridge is loaded.
- Cover sensor which detects whether the front cover is closed.
- Jam sensor which detects whether paper is jammed inside the heat-fixing unit.
- Heater thermistor which allows the controller to monitor the temperature of the heater roller of the fixing unit.
- In-casing temperature sensor which allows the controller to monitor the temperature inside the equipment.
- Hook switch\* which detects whether the handset is placed on the handset mount\*.

The above photosensors are a photo-interrupter consisting of a light-emitting diode and a light-sensitive transistor. Each of them has an actuator separately arranged as shown on the next page.

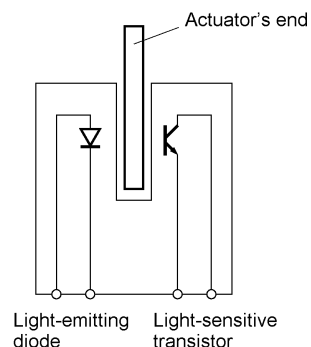

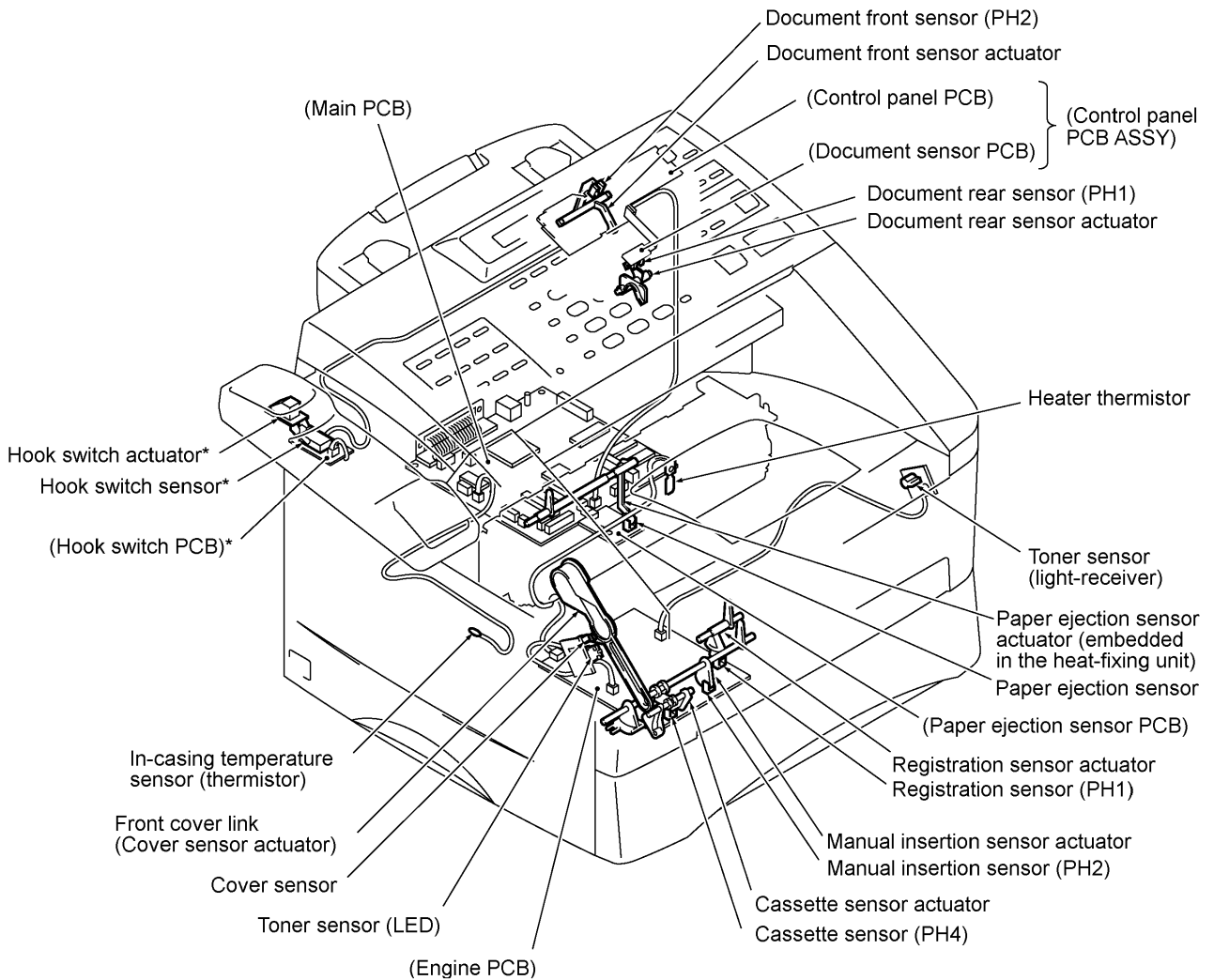

\* Provided on models equipped with a handset.

**NOTE:** Jam sensor

The machine has a jam sensor (not shown in the above illustration) which is on the heat-fixing unit.

**Location of Sensors and Actuators**

### 3. CONTROL ELECTRONICS

The hardware configuration of the facsimile equipment is shown below.

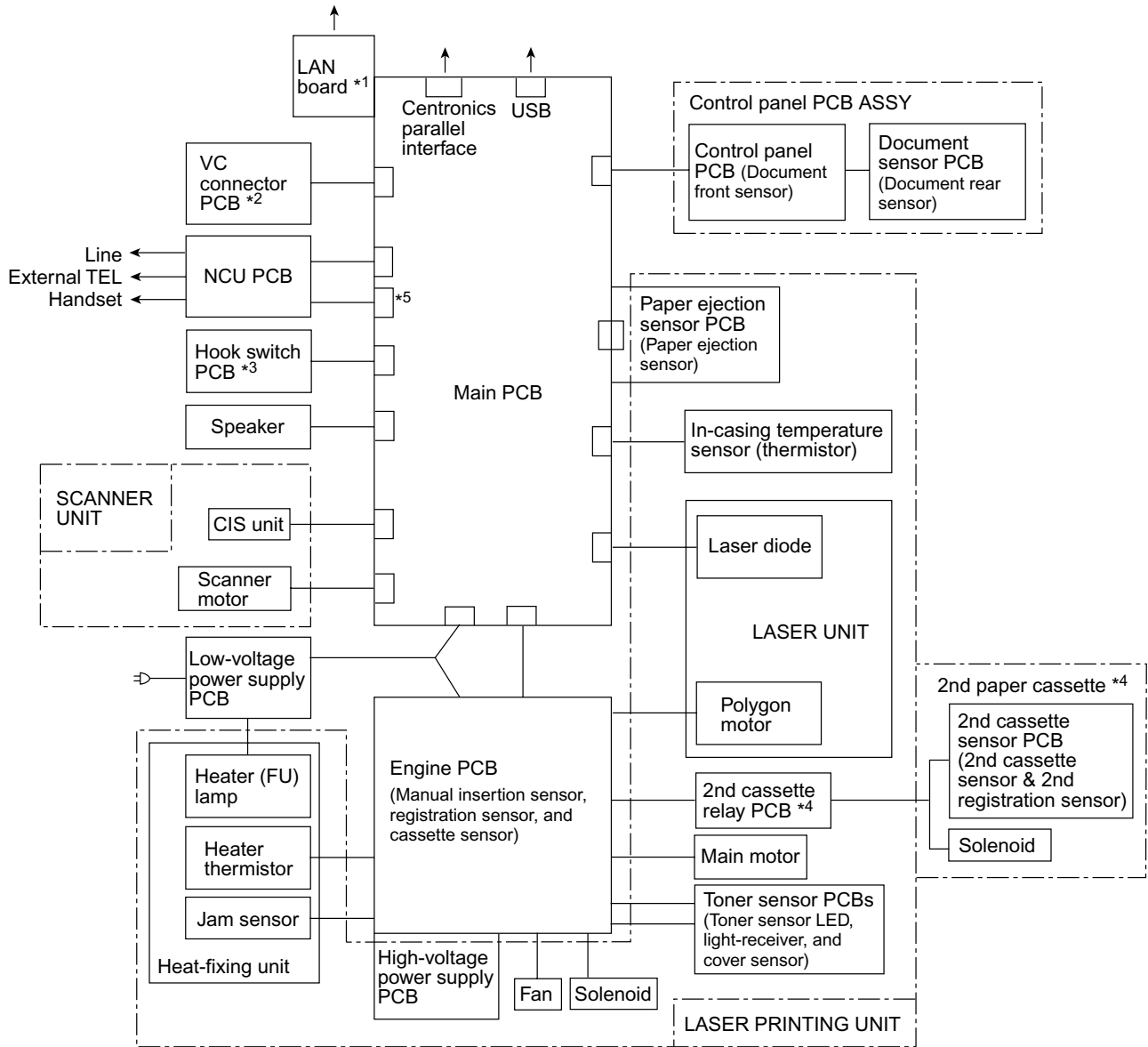

- \*1 Provided on models supporting LAN interface.
- \*2 Models supporting the video capture are not available now.
- \*3 Provided on models equipped with a handset.
- \*4 Provided on models available with a 2nd paper cassette (as an option or standard).
- \*5 Provided on European models.

Configuration of Facsimile Equipment

# **CHAPTER IV.**

## **DISASSEMBLY/REASSEMBLY AND LUBRICATION**

# CHAPTER IV. DISASSEMBLY/REASSEMBLY AND LUBRICATION

## CONTENTS

<b>1.</b>	<b>DISASSEMBLY/REASSEMBLY .....</b>	<b>IV-1</b>
■	Safety Precautions .....	IV-1
■	Preparation.....	IV-2
■	How to Access the Object Component .....	IV-2
■	Disassembly Order Flow.....	IV-3
1.1	Rear Cover .....	IV-4
1.2	Access Plates R and F .....	IV-4
1.3	Control Panel ASSY .....	IV-5
1.4	Panel Rear Cover and Control Panel .....	IV-6
1.5	Document Feed Roller ASSY, Document Ejection Roller ASSY, and Pinch Rollers .....	IV-9
1.6	CIS Unit .....	IV-10
1.7	Scanner Frame ASSY (Scanner Motor, Scanner Drive Unit, Document Take-in Roller, Separation Roller, Pressure Rollers, and Control Panel Locks) .....	IV-11
1.8	Top Cover (Exit Roller, Speaker, and Document Guides).....	IV-15
1.9	Handset Mount and Hook Switch PCB (for models equipped with a handset) Side Cover (for models without handset) .....	IV-21
1.10	Paper Sub Tray .....	IV-23
1.11	VC Cover, VC Bracket, and VC Connector PCB (for models supporting video capture) .....	IV-24
1.12	Front Cover Front Sub Cover (for models not supporting video capture) .....	IV-25
1.13	Outer Chute and Paper Pinch Rollers .....	IV-26
1.14	Main Cover .....	IV-27
1.15	Switch Cover .....	IV-28
1.16	Laser Unit .....	IV-29
1.17	Heat-fixing Unit and FU Lamp .....	IV-30
	[Disassembling the heat-fixing unit].....	IV-32
1.18	Fan .....	IV-44
1.19	Drive Gear ASSY and Main Motor ASSY .....	IV-46
1.20	NCU Shield and NCU PCB.....	IV-48
1.21	Bottom Plate, Main PCB and Bottom Insulation Film .....	IV-50
1.22	Low-voltage Power Supply PCB and Power Inlet.....	IV-54



1.23	Inner Insulation Film, High-voltage Power Supply PCB, Engine PCB, and 2nd Cassette Relay PCB* .....	IV-56
1.24	Toner Sensor (light-receiver) PCB and Toner Sensor (LED) PCB.....	IV-58
1.25	Gears and Paper Pick-up Roller.....	IV-59
1.26	Paper Feed Roller ASSY .....	IV-60
1.27	Clutch Levers, Cassette Guide L, and Solenoid.....	IV-61
1.28	Paper Cassette.....	IV-62
1.29	Cleaning of High-voltage Contacts and Grounding Contacts .....	IV-63
<b>2.</b>	<b>LUBRICATION .....</b>	<b>IV-65</b>
[ 1 ]	Document feed roller ASSY and document ejection roller ASSY.....	IV-65
[ 2 ]	Control panel locks .....	IV-66
[ 3 ]	Scanner frame ASSY, document take-in roller and its shaft, and separation roller and its shaft .....	IV-66
[ 4 ]	Top cover .....	IV-67
[ 5 ]	Drive gear ASSY .....	IV-68
[ 6 ]	Paper cassette .....	IV-69

# 1. DISASSEMBLY/REASSEMBLY

## ■ Safety Precautions

To prevent the creation of secondary problems by mishandling, observe the following precautions during maintenance work.

- (1) Unplug the power cord from the power outlet before accessing parts or units inside the machine. When having access to the power supply, be sure to unplug the power cord from the power outlet.
- (2) When servicing the optical system of the laser printing unit, be careful not to place screwdrivers or other reflective objects in the path of the laser beam. Be sure to take off any personal accessories such as wrist watches and rings before working on the printer. A reflected beam, though invisible, can permanently damage your eyes.
- (3) If the equipment has been printing, allow the heat-fixing unit (inside this unit is a red-colored heater roller) sufficient time to cool down before starting maintenance jobs. It is HOT!
- (4) Be careful not to lose screws, washers, or other parts removed for parts replacement.
- (5) Do not remove gears from the document feed roller ASSY or document ejection roller ASSY if at all possible. Once removed, they will become unusable and new gears will have to be put back in.
- (6) When using soldering irons and other heat-generating tools, take care not to damage the resin parts such as wires, PCBs, and covers.
- (7) Before handling the PCBs, touch a metal portion of the equipment to discharge static electricity; otherwise, the electronic parts may be damaged due to the electricity charged in your body.
- (8) When transporting PCBs, be sure to wrap them in conductive sheets such as aluminum foil.
- (9) Be sure to reinsert self-tapping screws correctly, if removed. Unless otherwise specified, tighten screws to the following torque values:

Taptite, bind B and cup B	M3: 0.7 N•m
	M4: 0.8 N•m
Taptite, cup S	M3: 0.8 N•m
Other screws	M3: 0.7 N•m
	M4: 0.8 N•m

- (10) When connecting or disconnecting cable connectors, hold the connector bodies not the cables. If the connector has a lock, always slide the connector lock to unlock it.
- (11) Before reassembly, apply the specified lubricant to the specified points. (Refer to Section 2 in this chapter.)
- (12) After repairs, check not only the repaired portion but also that the connectors and other related portions function properly before operation checks.

## ■ Preparation

Prior to proceeding to the disassembly procedure,

### (1) Unplug

- the power cord,
- the modular jack of the telephone line,
- the modular jack of the curled cord (and remove the handset)\*,
- the PC interface cable, and
- the modular jack of an external telephone set if connected. (Not shown below.)

### (2) Remove

- the document support,
- the document tray,
- the paper cassette, and
- the drum unit (with toner cartridge loaded)

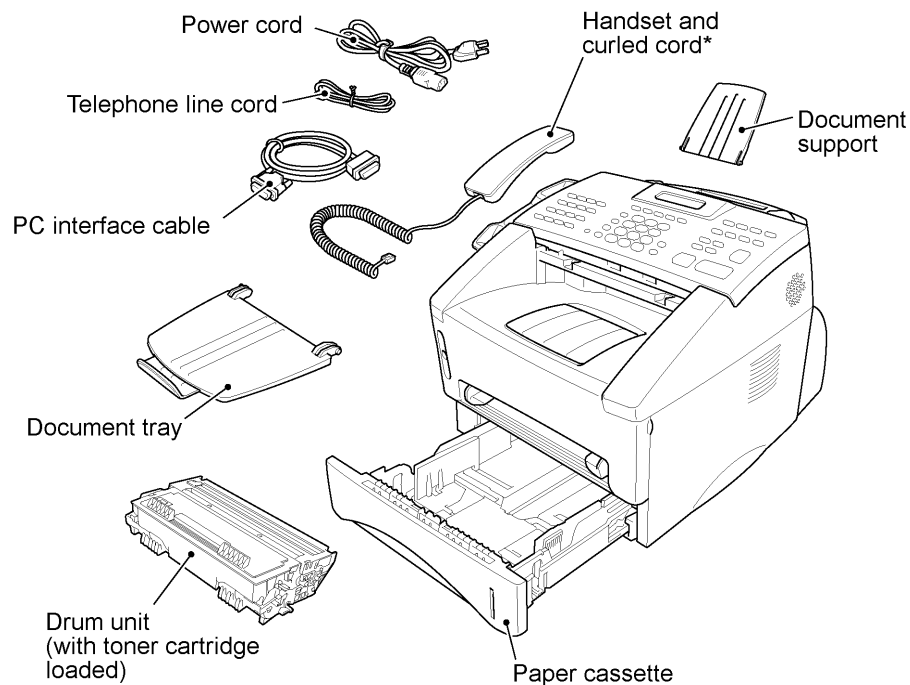

(\*For those models equipped with handset.)

## ■ How to Access the Object Component

- On the next page is a disassembly order flow which helps you access the object components. To remove the heat-fixing unit, for example, first find it on the flow and learn its number (①.17 in this case). You need to remove parts numbered ①.3, ①.7, ①.8, ①.11, ①.12, and ①.14 so as to access the heat-fixing unit.
- Unless otherwise specified, the disassembled parts or components should be reassembled in the reverse order of removal.

■ Disassembly Order Flow

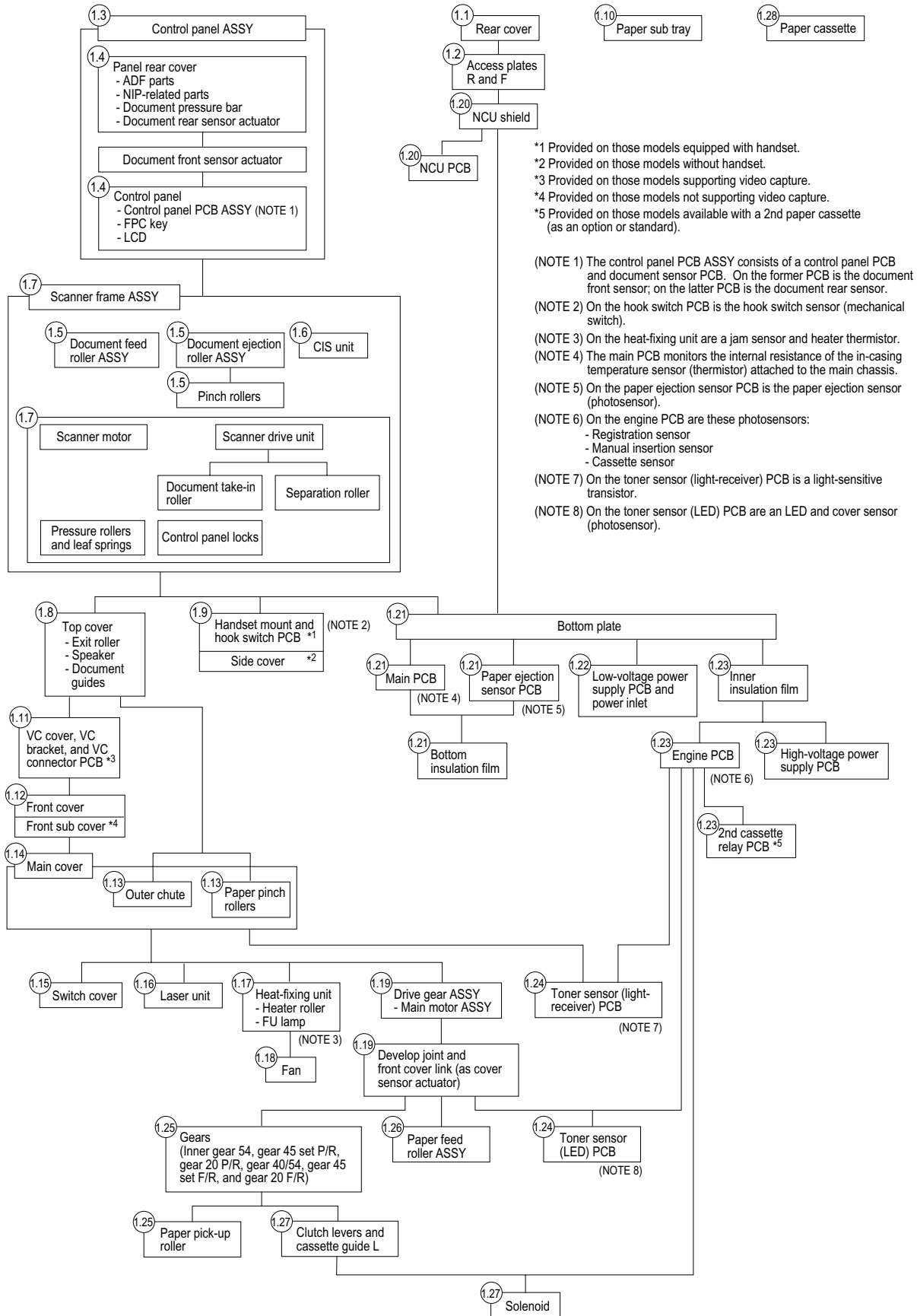

### 1.1 Rear Cover

- (1) FAX8350P and FAX8750P: Remove the sub rear cover.
- (2) Remove the three screws (two "a" and one "b") from the rear cover. Screw "b" is provided on those models available with a 2nd paper cassette (as an option or standard).
- (3) Lightly pressing sections "X," pull out the rear cover.

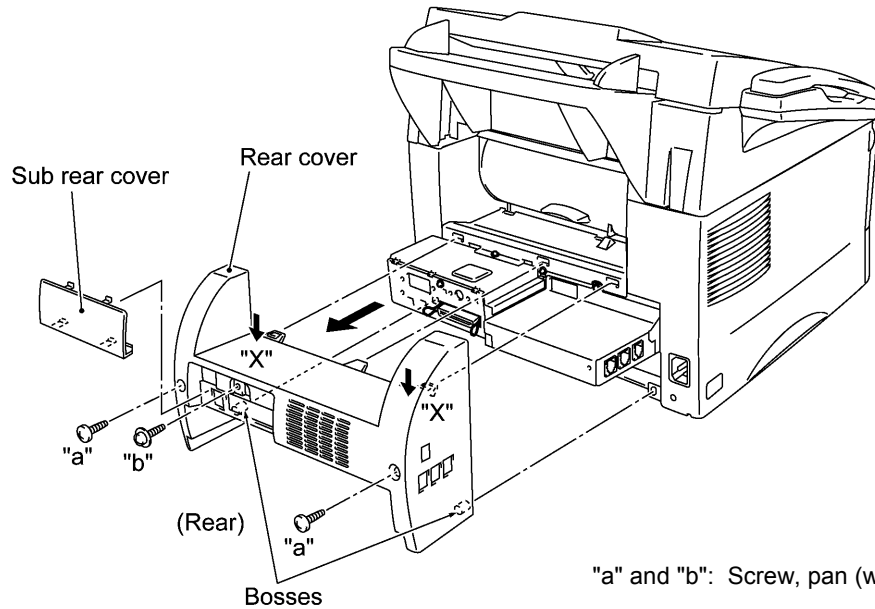

### 1.2 Access Plates R and F

- (1) Remove screw "c" that secures access plates R and F together to the main chassis.
- (2) Remove screws "d" and "e" from access plate R.
- (3) Take out access plates R and F together.
- (4) Remove screw "f" to separate those access plates.

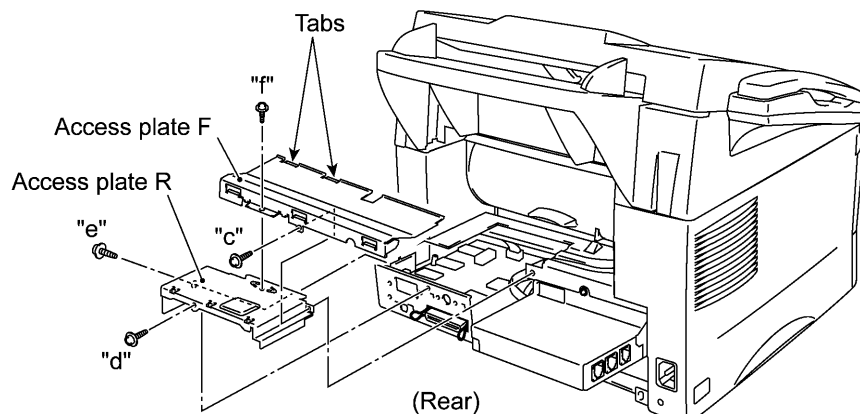

#### ■ Reassembling Notes

- When reinstalling access plate F, fit the two tabs provided on the front end underneath the center edge of the main chassis.

### 1.3 Control Panel ASSY

- (1) Slightly open the control panel ASSY.
- (2) Push the right and left arms of the control panel ASSY outwards (in the direction of arrow ①) with your thumbs, then open the control panel ASSY further (arrow ② to unhook those arms from bosses "x" provided on the scanner frame ASSY) while sliding the control panel ASSY to the front (arrow ③ to release its bosses "y" from the grooves of the scanner frame ASSY).
- (3) Slightly lift up the control panel ASSY and disconnect the panel-main harness from the control panel PCB.

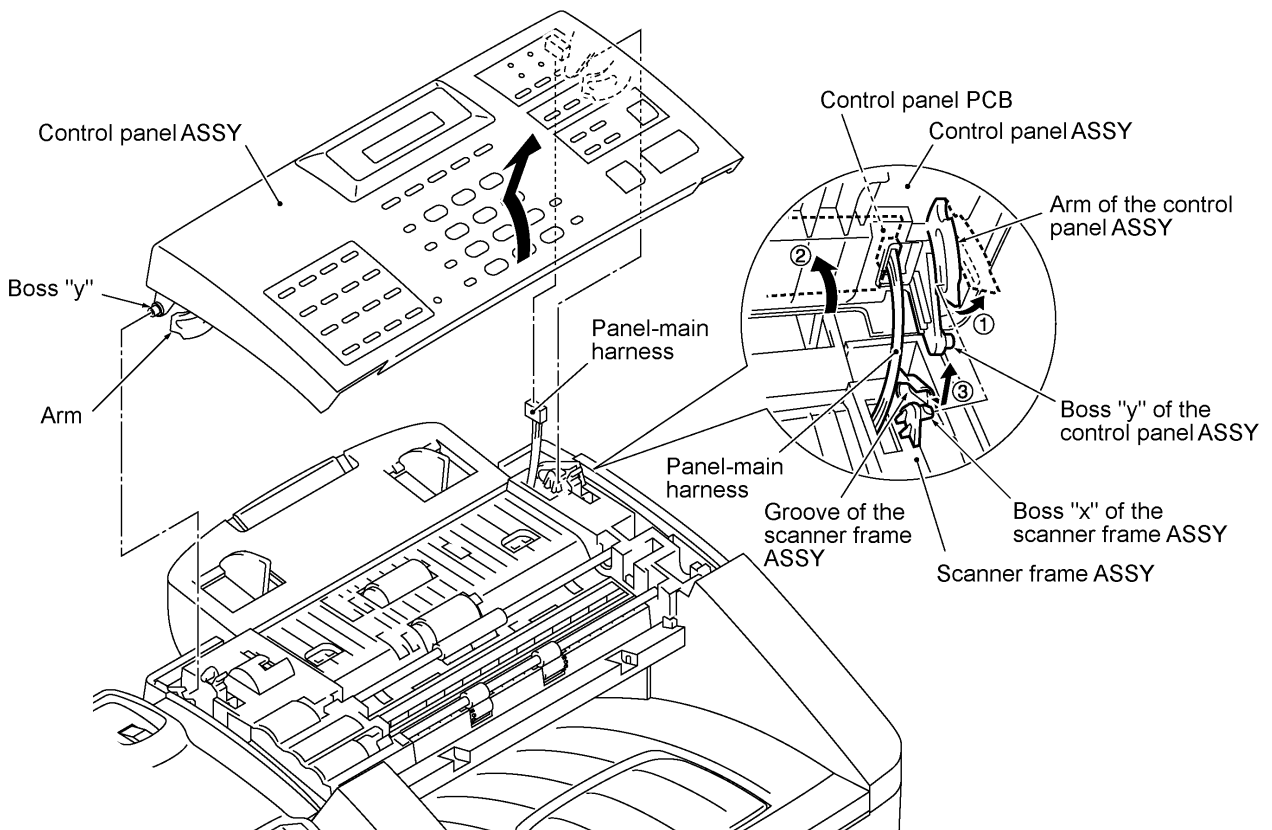

### 1.4 Panel Rear Cover and Control Panel

- (1) Place the control panel ASSY upside down.  
If you do not need to remove the ADF parts, nip-related parts, document pressure bar, or document rear sensor actuator, or anti-static brush, skip to step (7).
- (2) To remove the ADF parts (spring plates, separation rubber and spring), remove the screw.
- (3) To remove the nip-related parts (nip piece and spring), push down the nip piece (arrow ①) and then press either side of the piece inwards (arrow ②).

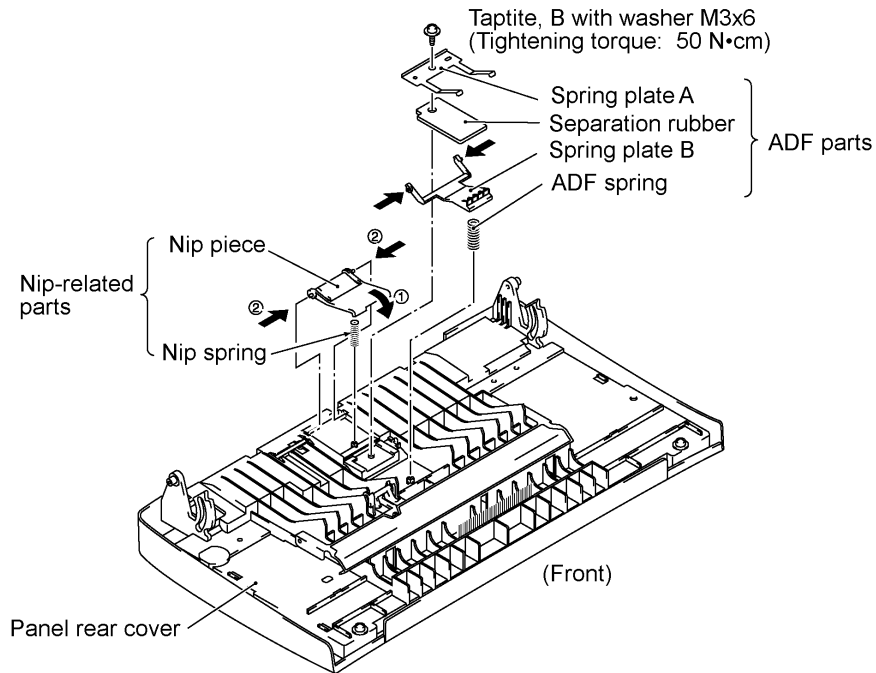

- (4) To remove the document pressure bar, press either of supports "a" provided on the panel rear cover inwards and then lift the pressure bar up and towards the rear to release the three tabs from the cutouts provided in the panel rear cover. The spring also comes off.
- (5) To remove the document rear sensor actuator, pull support "b" on the panel rear cover outwards.
- (6) To replace the anti-static brush, peel it off.

**NOTE:** Once removed, it will become unusable and a new part will have to be put back in.

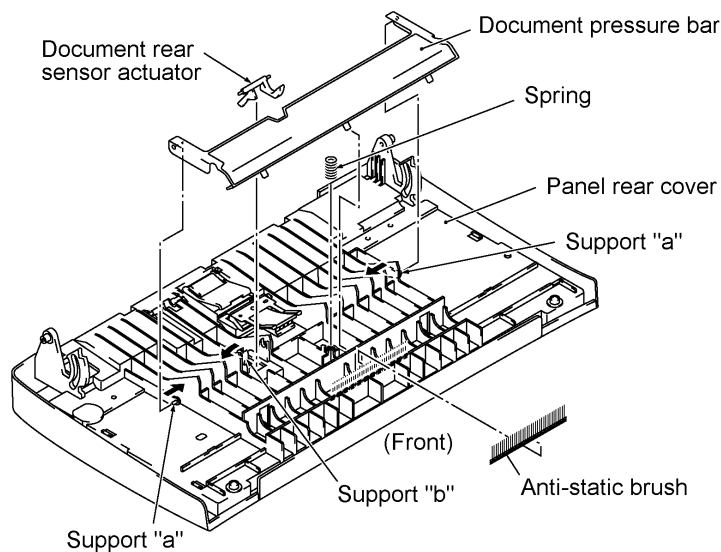

- (7) Remove the two screws from the panel rear cover.
- (8) Unhook the panel rear cover from eight "X" latches provided on the control panel and lift up the panel rear cover.
- (9) Fully turn the document front sensor actuator to the rear and take it out.
- (10) Unhook the document sensor PCB from two "Y" latches.
- (11) Unhook the control panel PCB from three "Z" latches.
- (12) Slightly lift up the control panel PCB, then unlock the LCD cable connector and disconnect the LCD flat cable. Next, unlock the FPC key connector and disconnect the FPC key.

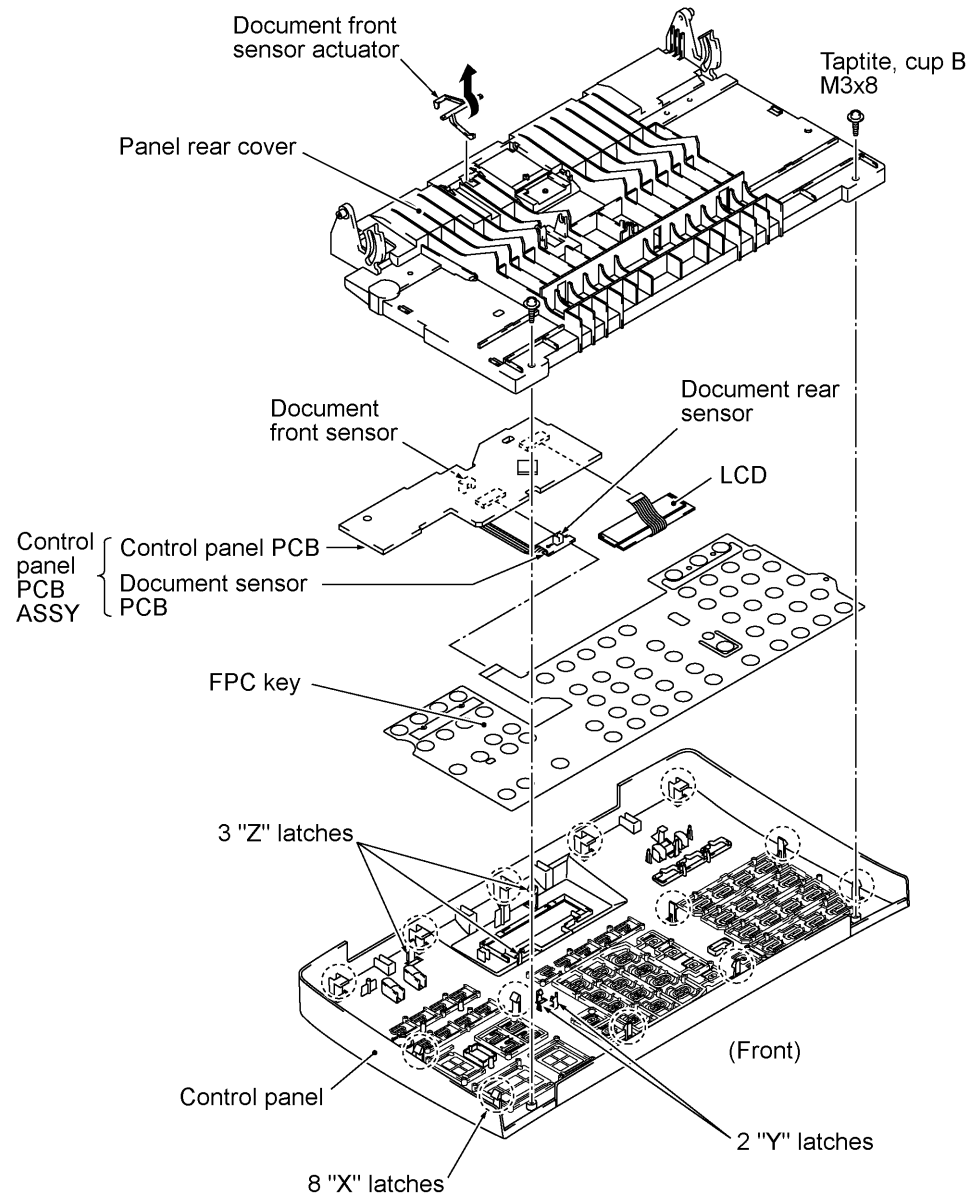



(13) As shown below, slightly pull the clamps to the front and take out the LCD while pulling the LCD flat cable gently.

**NOTE:** Do not take out the LCD except when the LCD is defective and requires replacement.

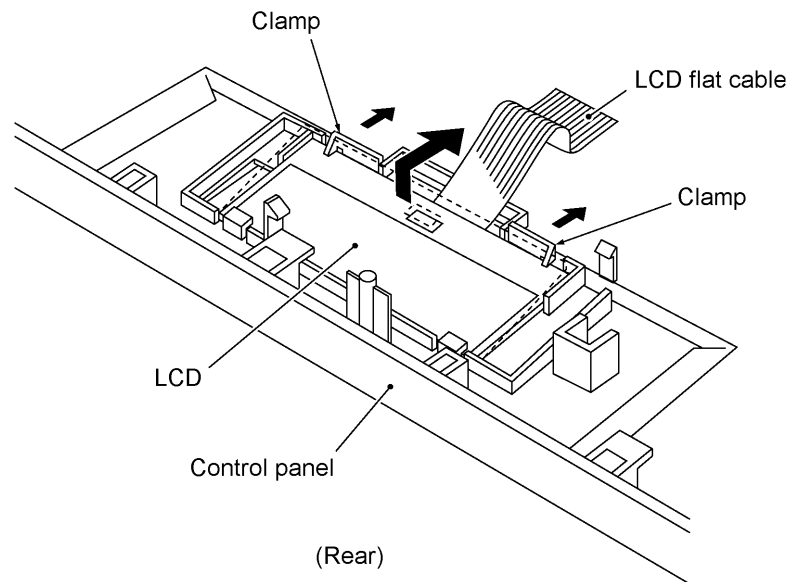

#### ■ Reassembling Notes

- Before reinstalling the LCD to the control panel, wipe fingerprints or dust off the LCD surface and control panel window with a soft cloth.
- A new LCD is covered with a protection sheet. Before installing it, remove the protection sheet.

1.5 Document Feed Roller ASSY, Document Ejection Roller ASSY, and Pinch Rollers

- (1) Lightly push arm rib "a" to the rear, then pull the document feed roller ASSY to the left and upwards.
- (2) Lightly push arm rib "b" to the rear, then pull the document ejection roller ASSY to the left and upwards.

**NOTE:** Take care not to break the arm ribs. They may easily break.

- (3) Pull up the pinch rollers and their shafts (springs).

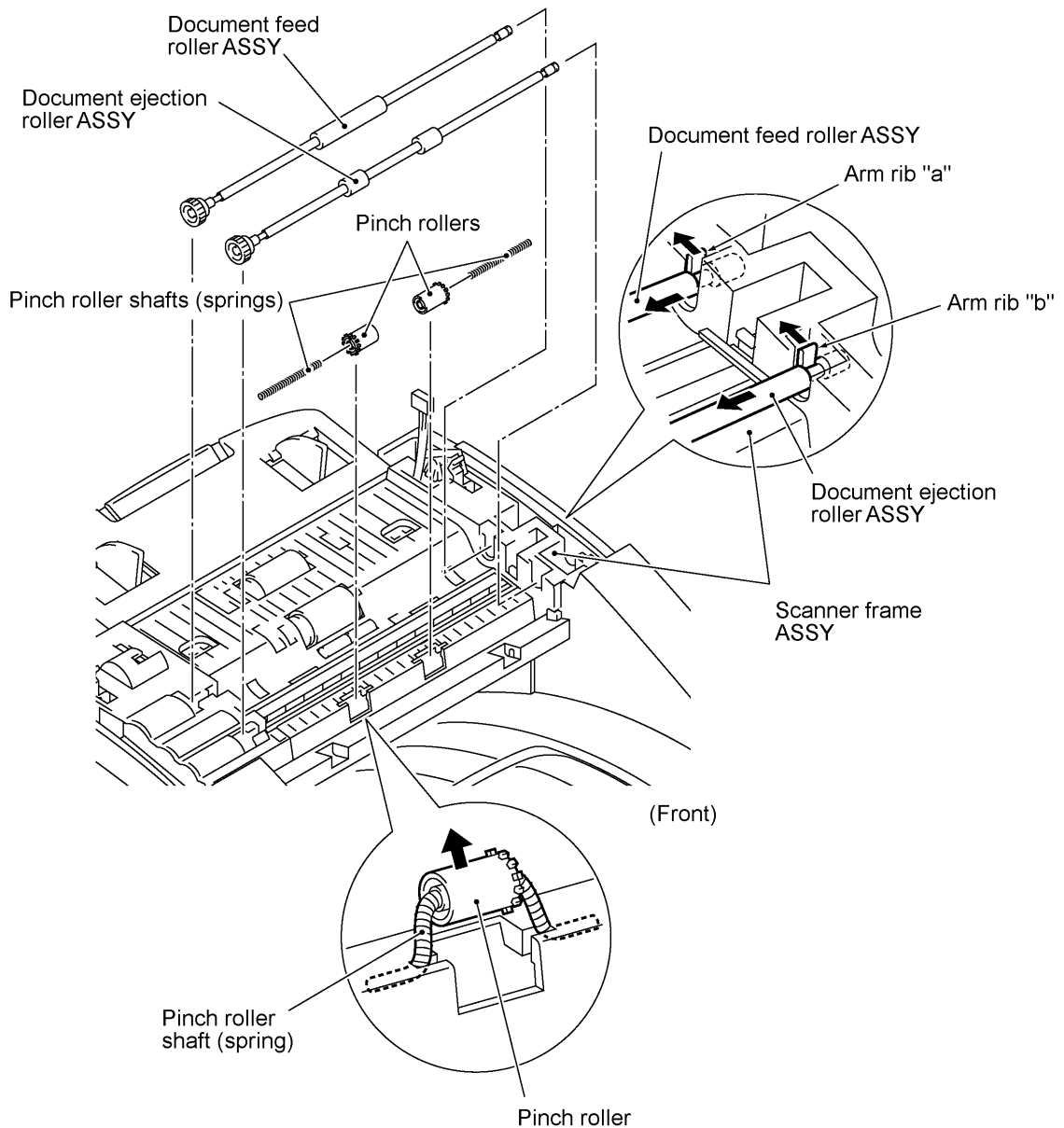

## 1.6 CIS Unit

- (1) Lightly pull up the arm, move the CIS unit to the right, and lift up the left edge of the CIS unit gently.

**NOTE:** Do not lift up the left edge exceeding 30 mm to prevent the CIS harness connector on the CIS unit from getting broken.

- (2) While holding up the CIS unit, disconnect the CIS harness. The CIS springs also come off.

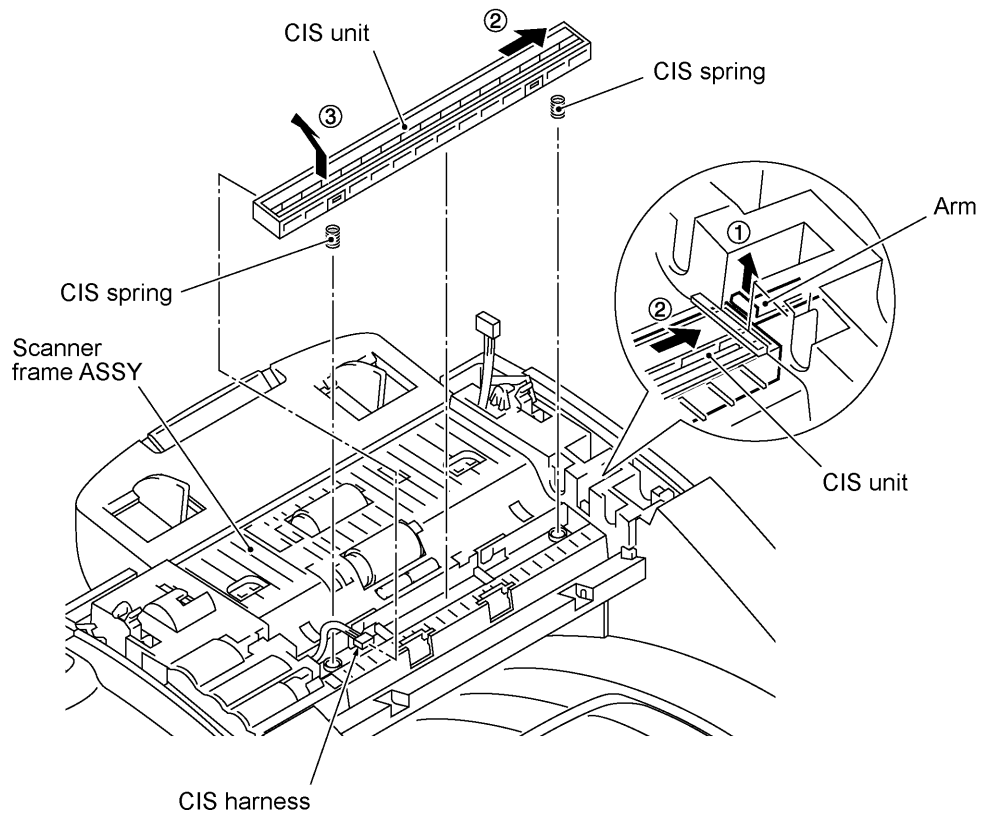

### ■ Reassembling Notes

- When reinstalling the CIS unit, first connect the CIS harness, insert the right end under the arm of the scanner frame, put the CIS unit into the scanner frame, and then move it to left.

**1.7 Scanner Frame ASSY (Scanner Motor, Scanner Drive Unit, Document Take-in Roller, Separation Roller, Pressure Rollers, and Control Panel Locks)**

- (1) Remove the two screws from the scanner frame ASSY.
- (2) Lift up the front edge of the scanner frame ASSY and pull the ASSY towards you to release the three tabs provided on the rear end from the top cover.

**NOTE:** If the CIS unit is mounted, do not lift up the scanner frame ASSY exceeding 30 mm to prevent the CIS harness connector on the CIS unit from getting broken.

- (3) Hold up the ASSY and disconnect the scanner motor harness (and the CIS harness if the CIS is mounted).

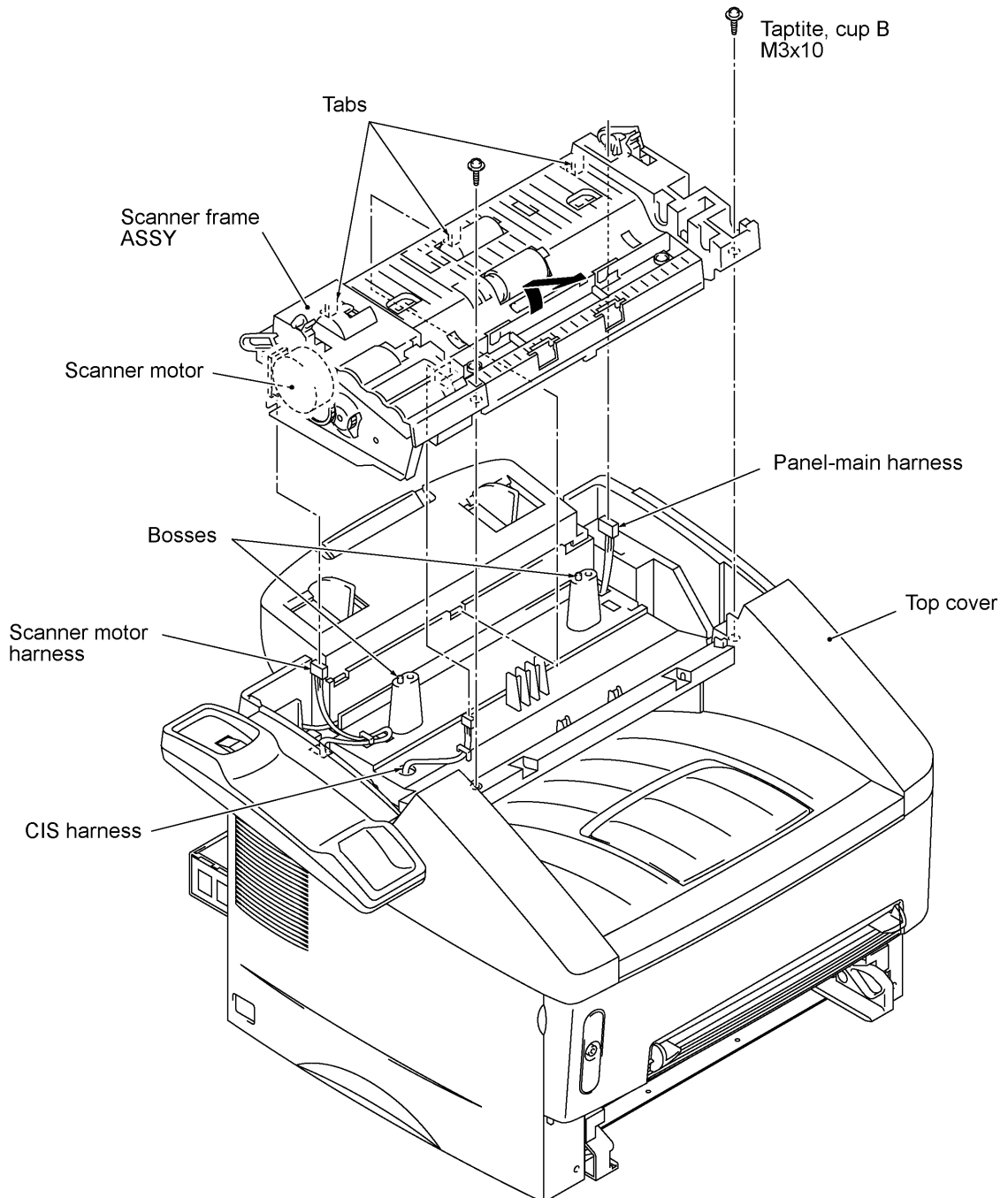

- (4) Turn the scanner frame ASSY upside down.
- (5) Remove the screw from the scanner motor and turn the motor (as shown below) to release it from the latch.

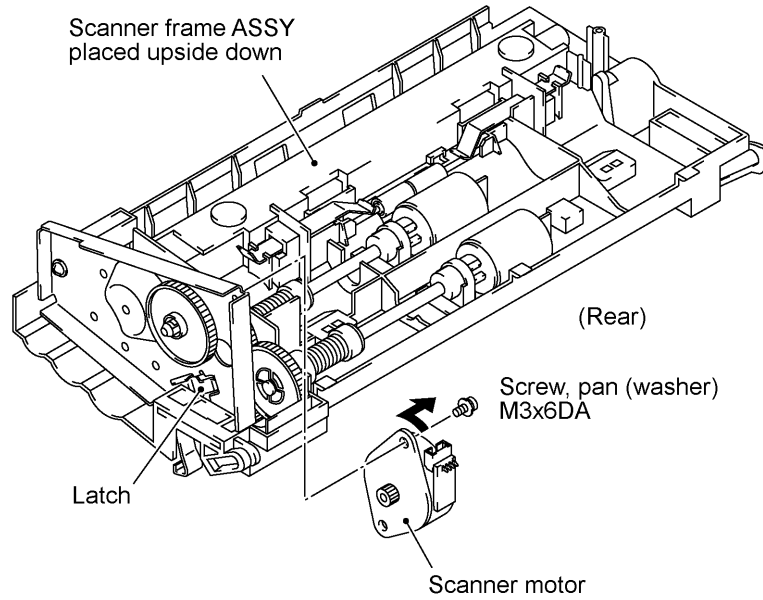

- (6) Remove the two screws and take off the scanner drive unit.

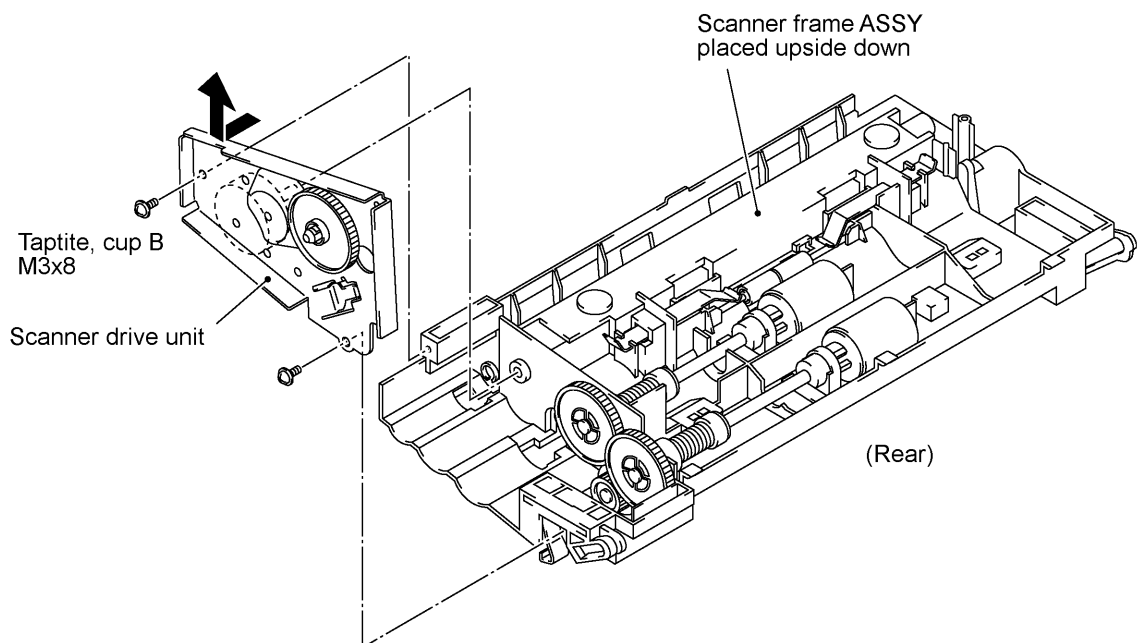

- (7) Remove the document take-in roller gear (in the direction of arrow ①) by pulling its pawls outwards. Slightly push down the arm (arrow ②) and shift the document take-in roller shaft to the left (arrow ③) and take it up.  
Then shift the document take-in roller to the left and take it up.
- (8) Remove the separation roller gear (in the direction of arrow ①) by pulling its pawls outwards. Slightly push down the arm (arrow ②) and shift the separation roller shaft to the left (arrow ③) and take it up.  
Then shift the separation roller to the left and take it up.

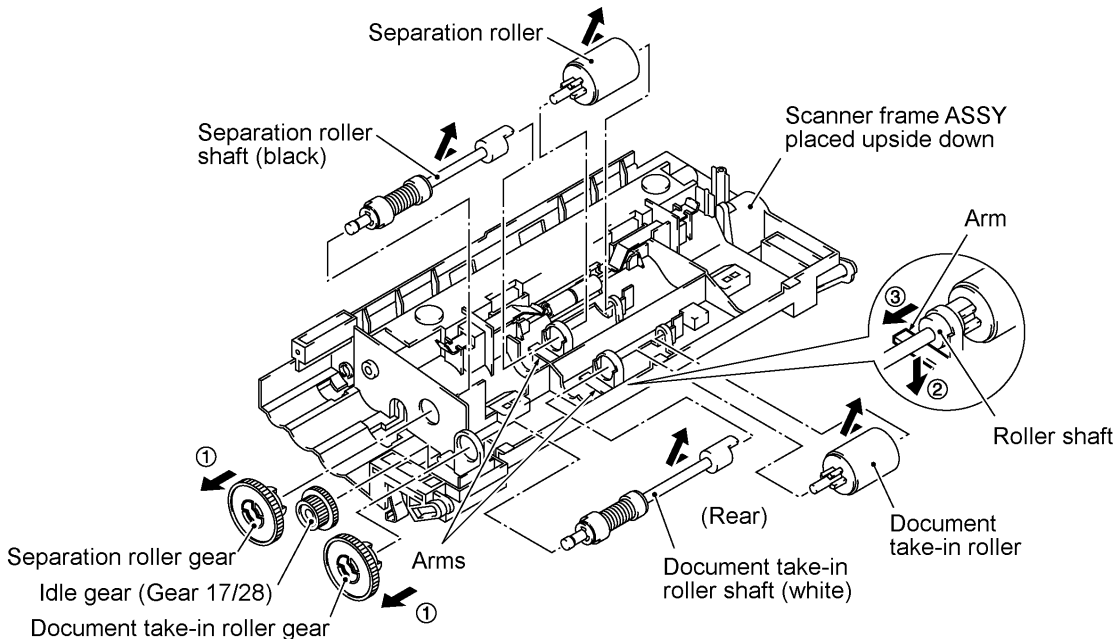

- (9) Remove the two pressure roller leaf springs by pulling them in the direction of arrows ① and ② in this order as shown below. Then remove the pressure rollers and shaft.
- (10) Remove the two control panel locks (leaf springs) with a flat screwdriver in the direction shown below.

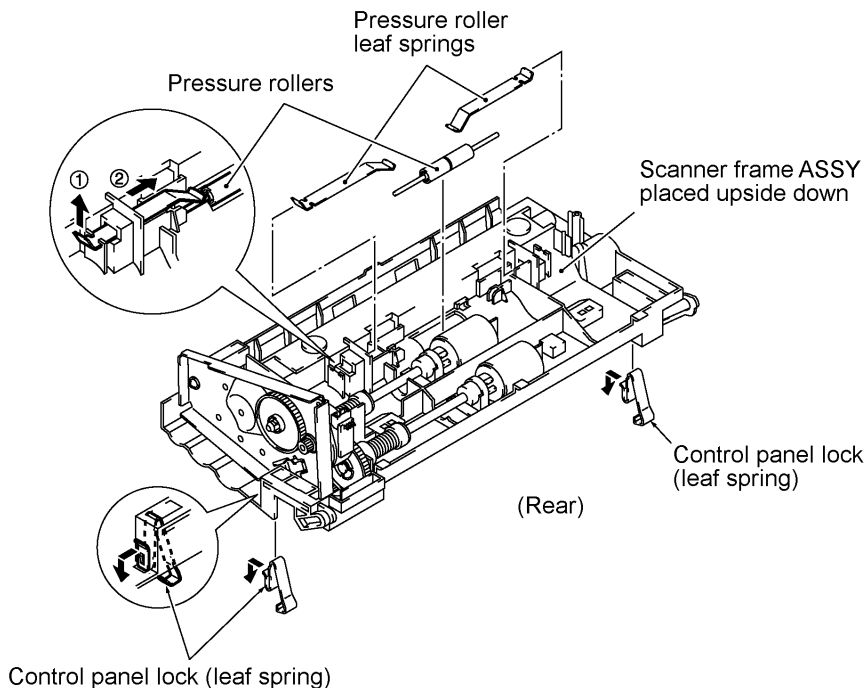

■ **Reassembling Notes**

- The document take-in roller and separation roller are compatible with each other. Their gears are also compatible with each other. However, their shafts are not compatible. The document take-in roller shaft should be a white one; the separation roller shaft should be a black one.

When setting these shafts to their rollers, fit the groove provided in each shaft over the longer boss provided on each roller.

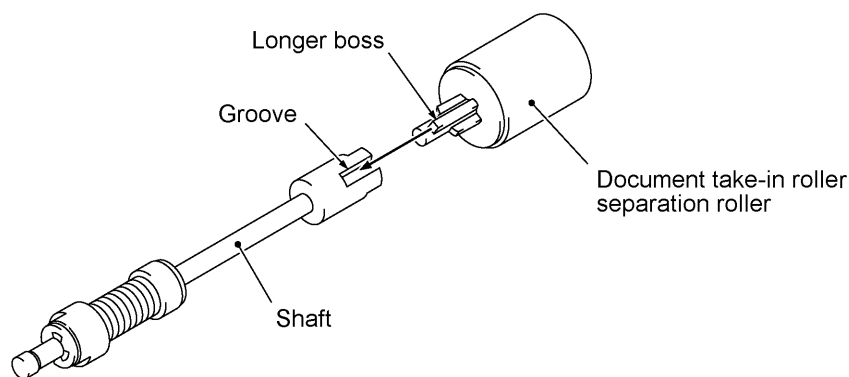

- When reinstalling the scanner motor, fit it in the latch provided on the scanner frame with the connector facing up and then secure it with the screw. (See page IV-12.)
- When setting the scanner frame ASSY back into place, be sure to
  - route the scanner motor harness through the hook on the top cover as shown on page IV-11 and connect it to the scanner motor,
  - route the CIS harness through the hook on the top cover as shown on page IV-11 and connect it to the CIS unit (if the CIS unit is not mounted, route the CIS harness through the left-hand cutout provided in the scanner frame ASSY), and
  - route the panel-main harness through the right-hand cutout provided in the scanner frame ASSY.

1.8 Top Cover (Exit Roller, Speaker, and Document Guides)

- (1) Disconnect the hook switch harness\* and speaker harness from the main PCB.

\*For models equipped with a handset

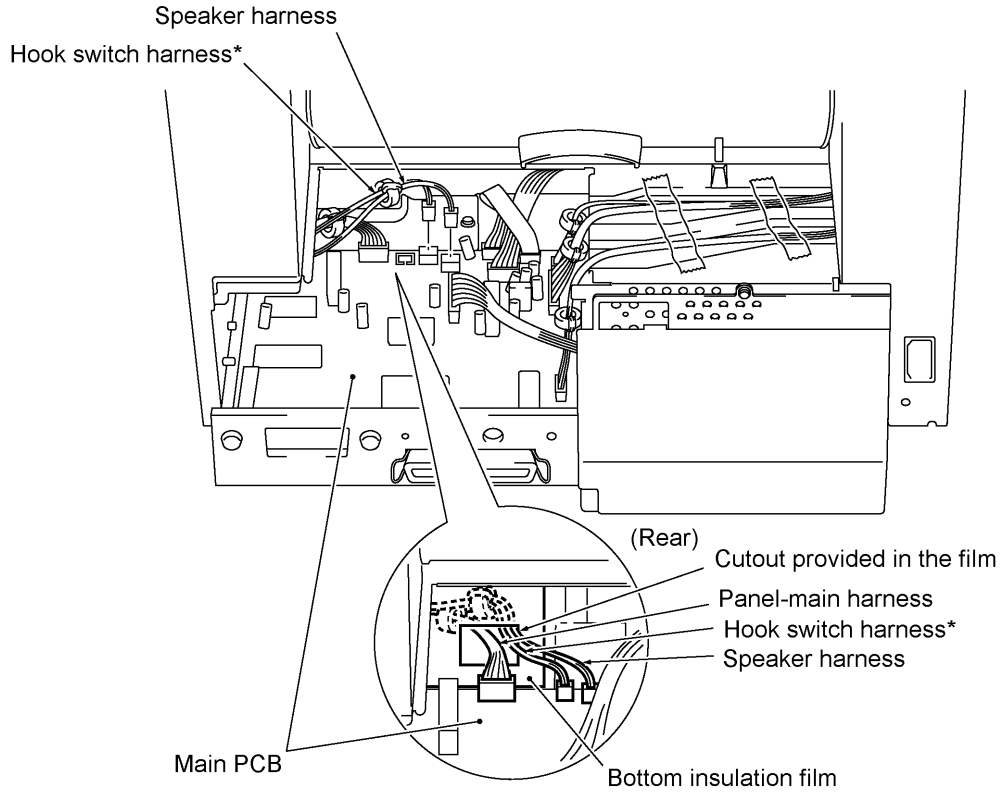

Routing the panel-main harness,  
hook switch harness\* and speaker harness

- (2) Remove the harness support rubbers to release the hook switch harness\*.  
 (3) Release the scanner motor harness and CIS harness from the hooks provided on the top cover.

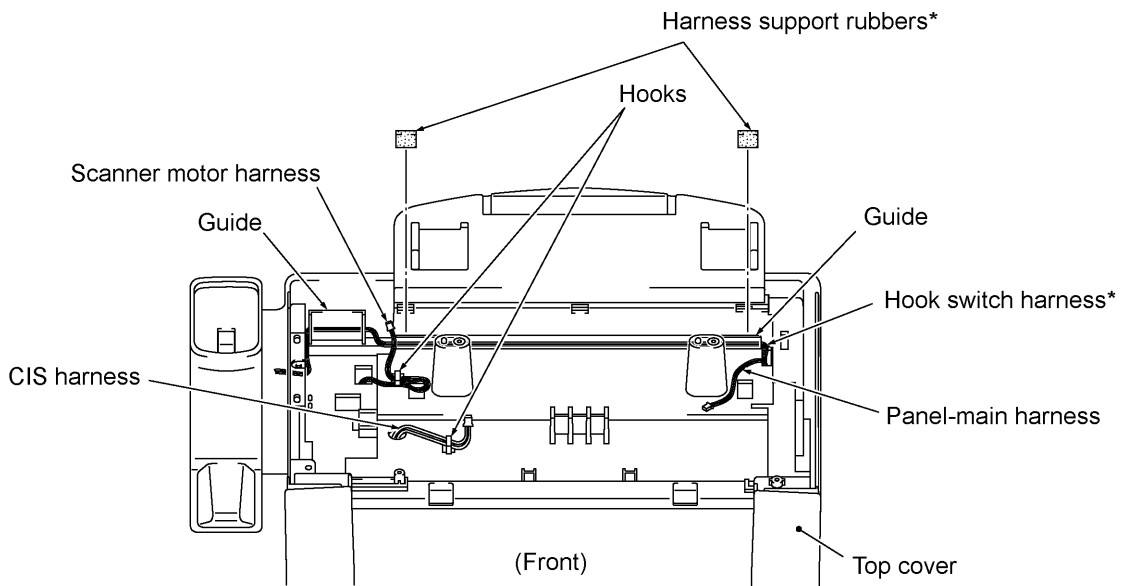



- (4) Remove two screws "a."
- (5) Open the front cover and remove two screws "b."
- (6) Pull the tabs of the top cover to the front and upwards (in the direction of arrows ①) to release them from the bosses provided on the main cover.
- (7) Insert the tip of a flat screwdriver and unhook the latches of the top cover (in the direction of arrows ②), then lift up the top cover (arrow ③).

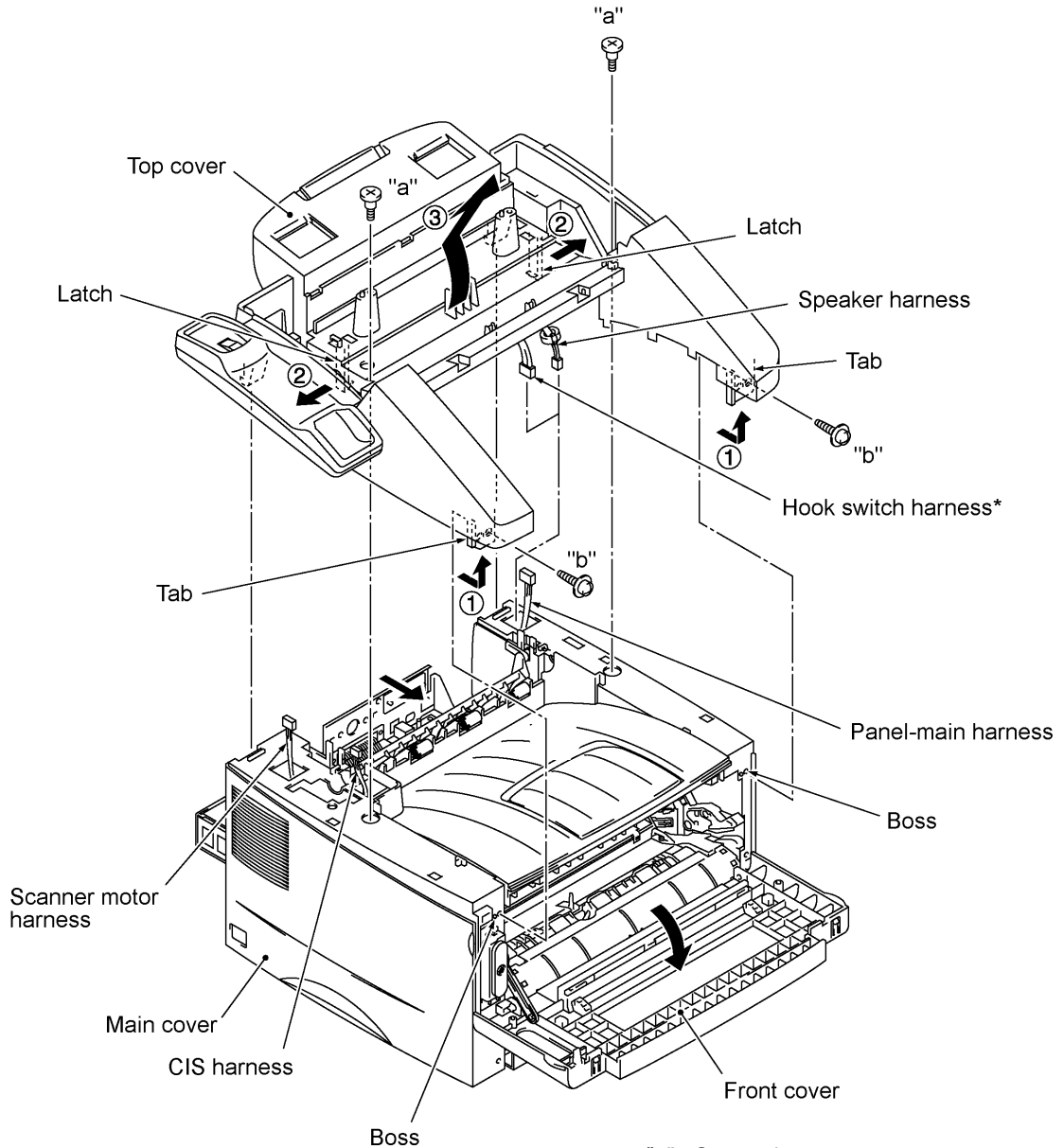

"a": Stepped screw  
 "b": Taptite, cup S M3x10

\*For models equipped with a handset

- (8) Turn the top cover upside down.
- (9) Peel off anti-static brushes.
  - NOTE:** Once removed, they will become unusable and new parts will have to be put back in.
- (10) As shown below, warp the gear-equipped end of the exit roller and remove it.

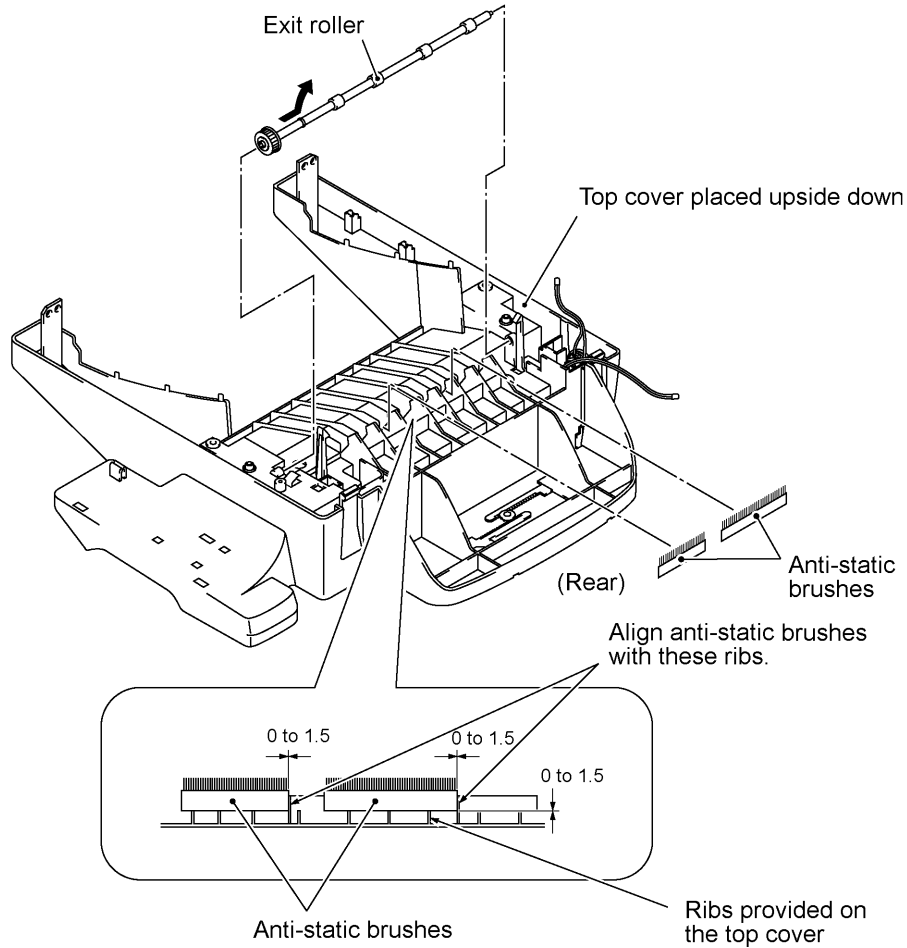

- (11) Unhook the latch from the speaker spring and pull it up. (To make this easier, insert the tip of a flat screwdriver from the bottom of the top cover placed upside down.) Lift up the speaker.

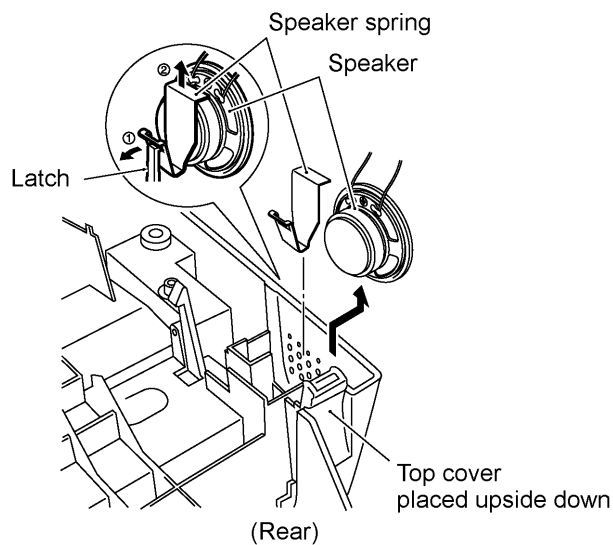

(12) Remove the screw from the inside of the top cover, then remove the document guides L and R as shown below.

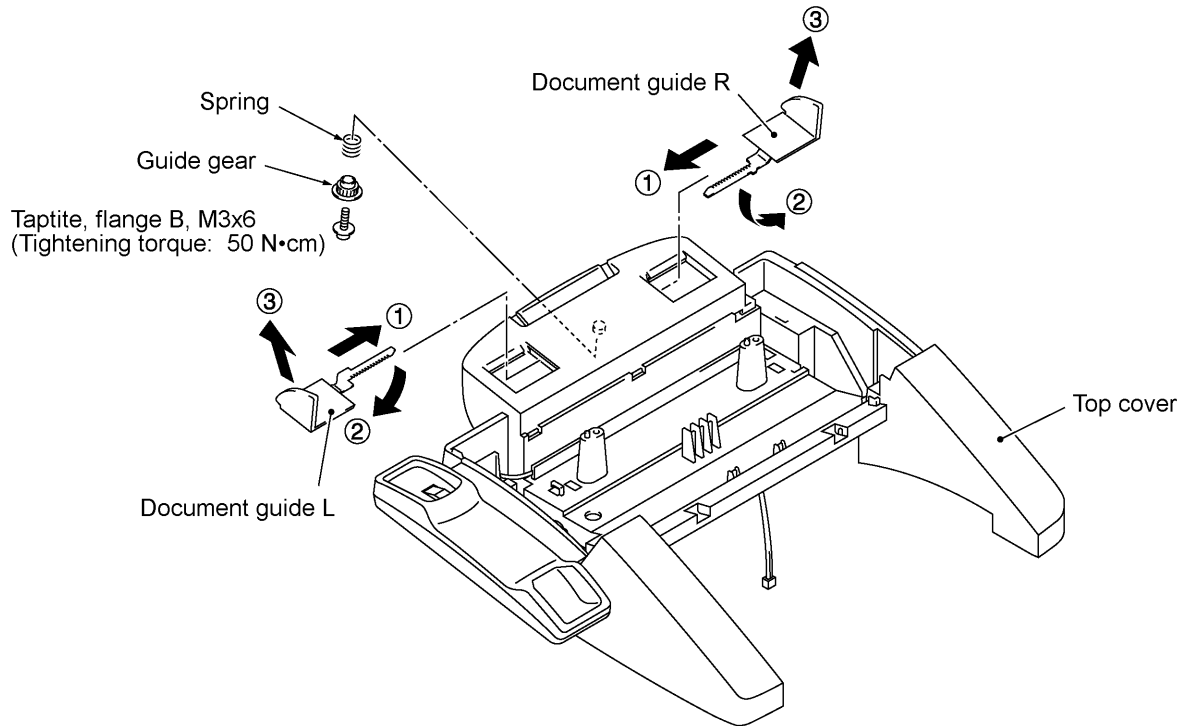

### ■ Reassembling Notes

- When reinstalling the paper guides, set them into place, pull them outwards (in the direction of arrows ①), and then secure them with the spring, guide gear, and screw (arrow ②).

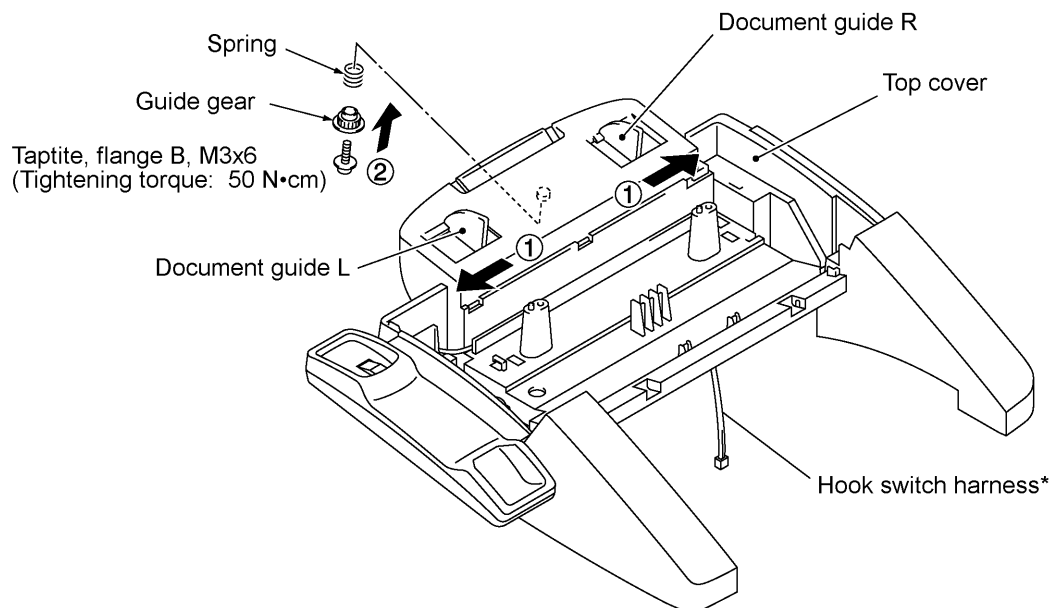

\*For models equipped with a handset

- When setting the top cover back into place:
  - at the right-hand side, put the speaker harness and hook switch harness\* into square cutout "X" provided in the right rear corner of the main cover. Raise the panel-main harness coming through the main cover up and through cutout "x" provided in the top cover (through which the hook switch harness\* passes).

If the panel-main harness has been taken out from the machine, first put it into square cutout "X" with the core-equipped end down and then raise its upper end up and through cutout "x" provided in the top cover.

- at the left-hand side, pull up the scanner motor harness and CIS harness and raise them up and through square and round cutouts ("y" and "z") provided in the top cover, respectively.

If the scanner motor harness or CIS harness has been taken out from the machine, first put it into the respective cutout ("Y" or "Z") provided in the left rear corner of the main cover with the core-equipped end down and then raise its upper end up and through the respective cutout "y" or "z."

\*For models equipped with a handset

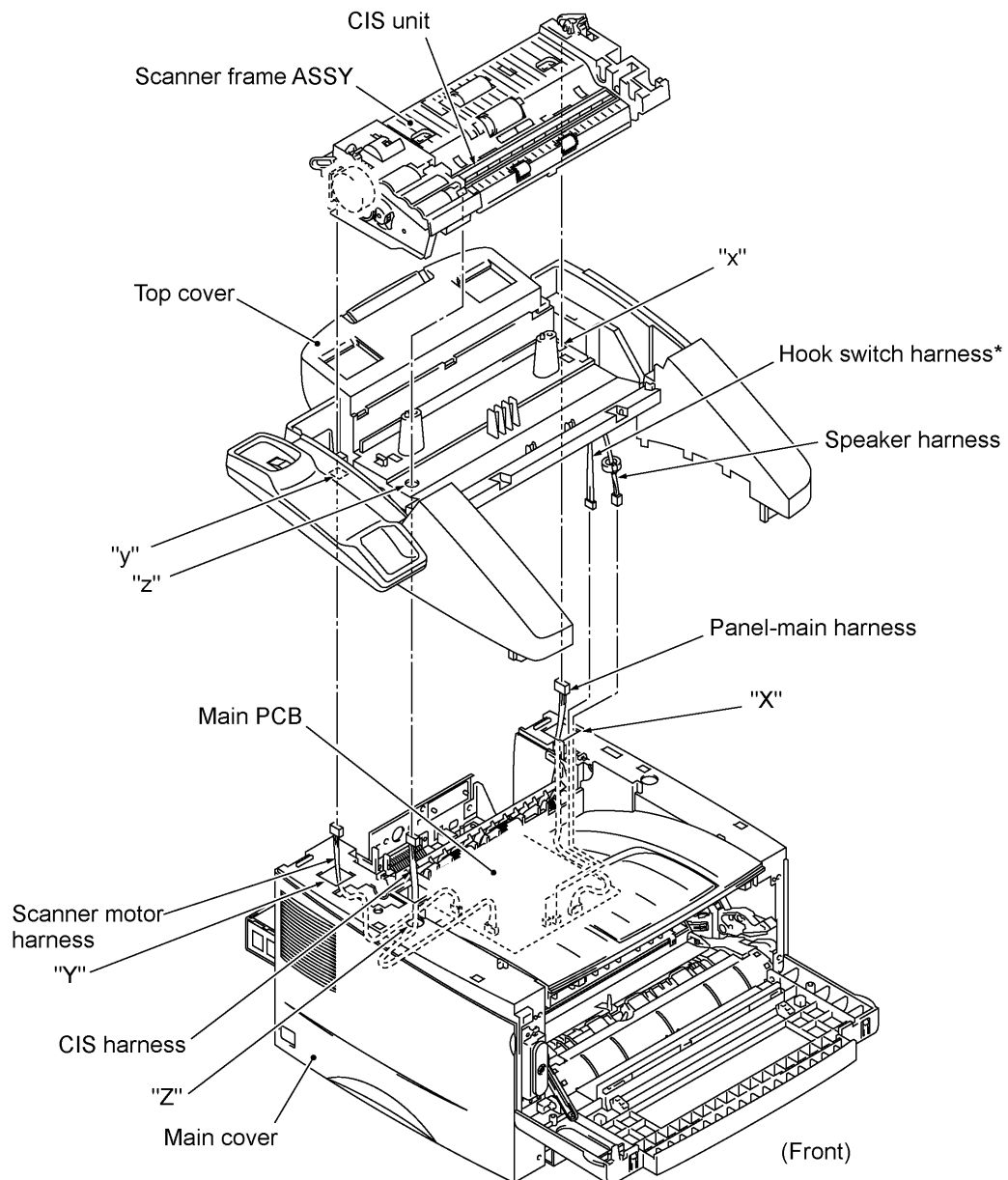

- When connecting the speaker harness and hook switch harness\* to the main PCB:
  - route the hook switch harness\* through the ferrite core of the speaker harness,
  - make sure that the panel-main harness, speaker harness, and hook switch harness\* are routed through the cutout provided in the bottom insulation film, and
  - make sure that the ferrite cores of the pane-main harness and speaker harness lie inside the bottom insulation film.

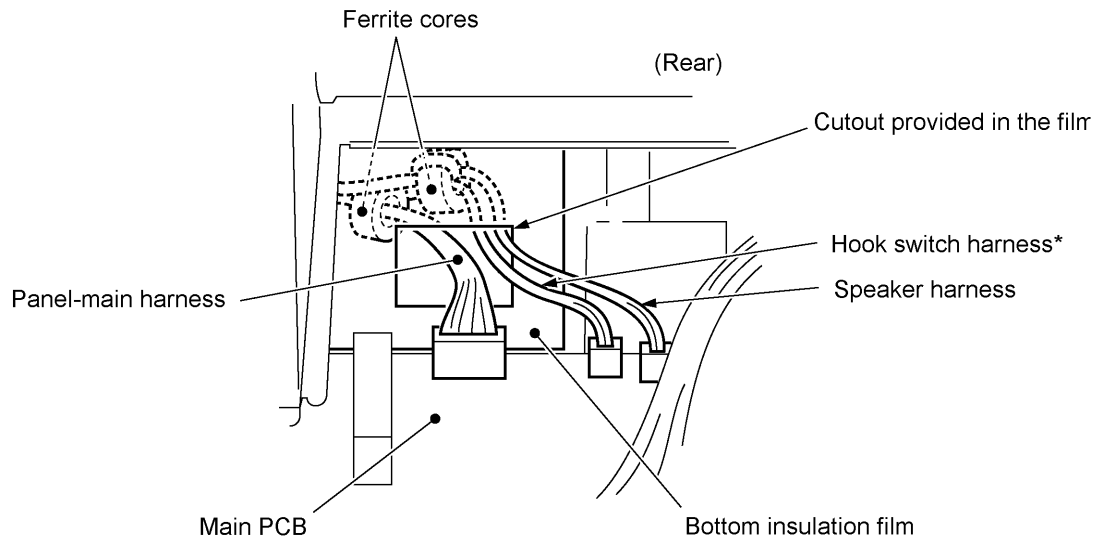

**1.9 Handset Mount and Hook Switch PCB (for models equipped with a handset)  
Side Cover (for models without handset)**

- (1) Remove the two screws from the handset mount\* or side cover\*\*.
- (2) Twist the handset mount\* or side cover\*\* so that it tilts over to the left and its upper end works out of the bosses provided on the top cover.

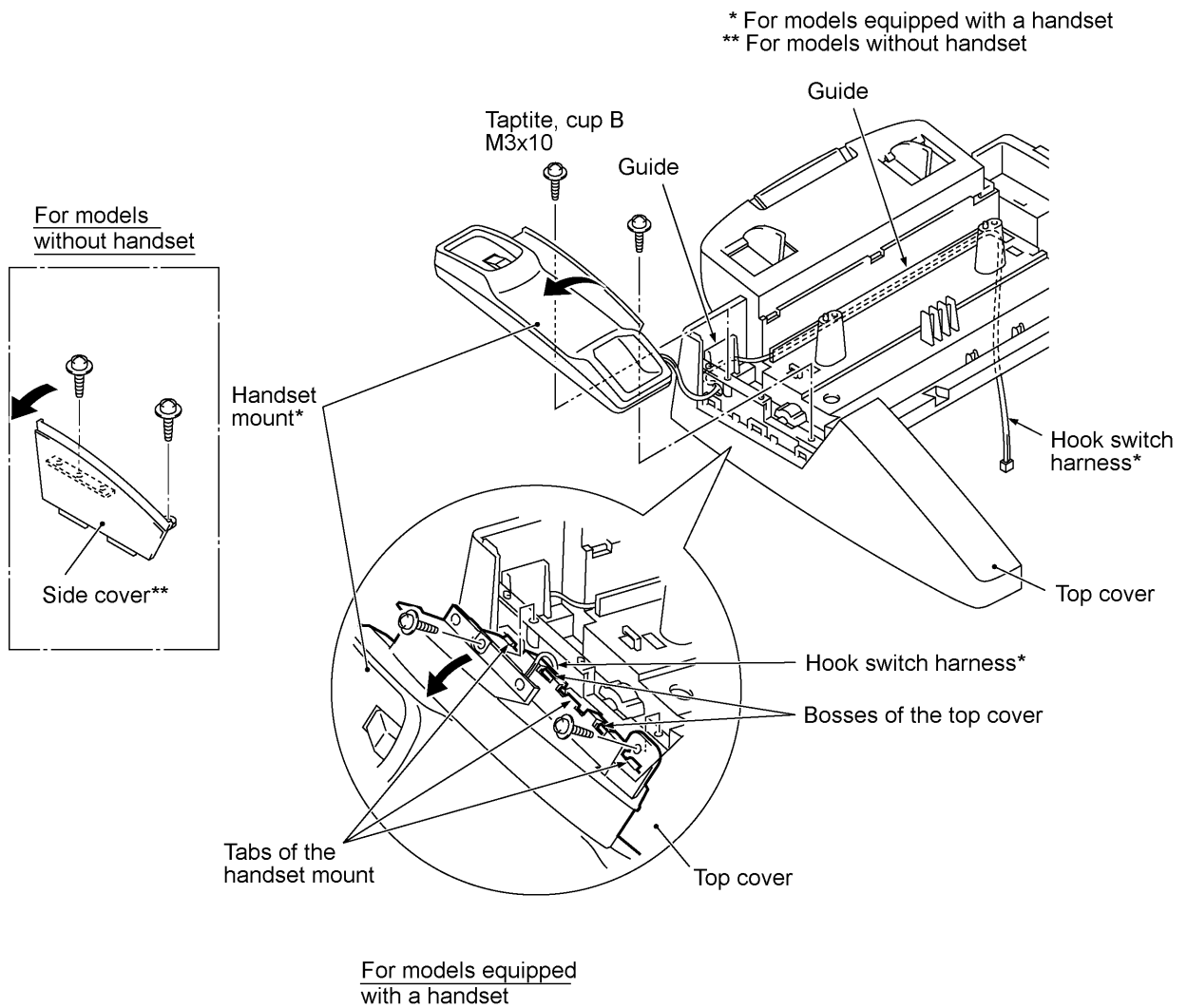

The following steps should apply to those models equipped with a handset:

- (3) Disassemble the handset mount by unhooking two latches "a" of the upper handset mount with a flat screwdriver.
- (4) Remove the hook switch PCB ASSY by unhooking latch "b."
- (5) Disconnect the hook switch harness from the hook switch PCB.

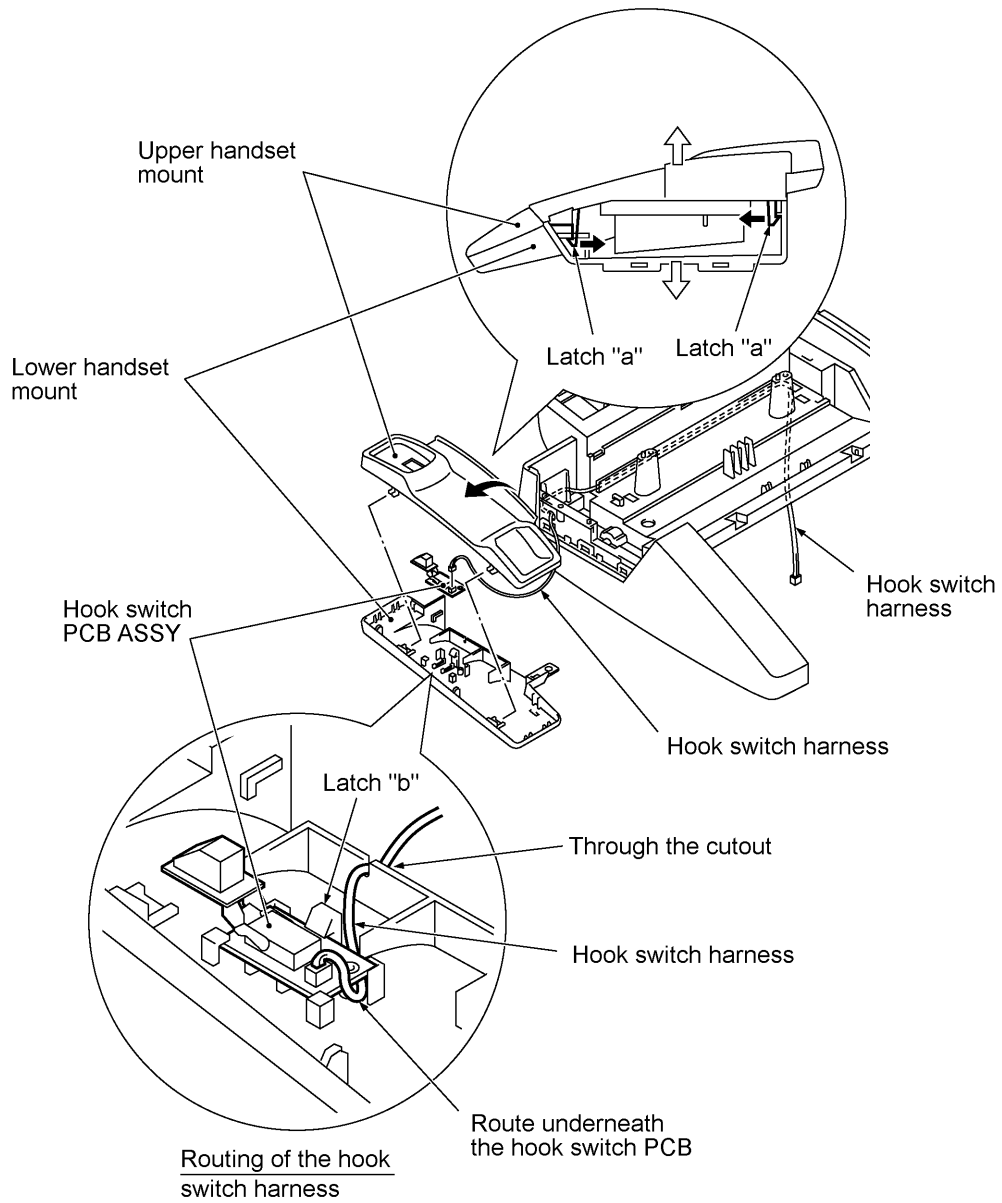

#### ■ Reassembling Notes

- When assembling the upper and lower handset mounts, route the hook switch harness underneath the hook switch PCB and through the cutout as shown above. Take care not to pinch the harness between the upper and lower mounts.
- Make sure that the hook switch harness is routed along the guides on the top cover.

### 1.10 Paper Sub Tray

- (1) Turn the paper sub tray up (in the direction of arrow ①).
- (2) Warp the sub tray and lift it up (arrows ② and ③).

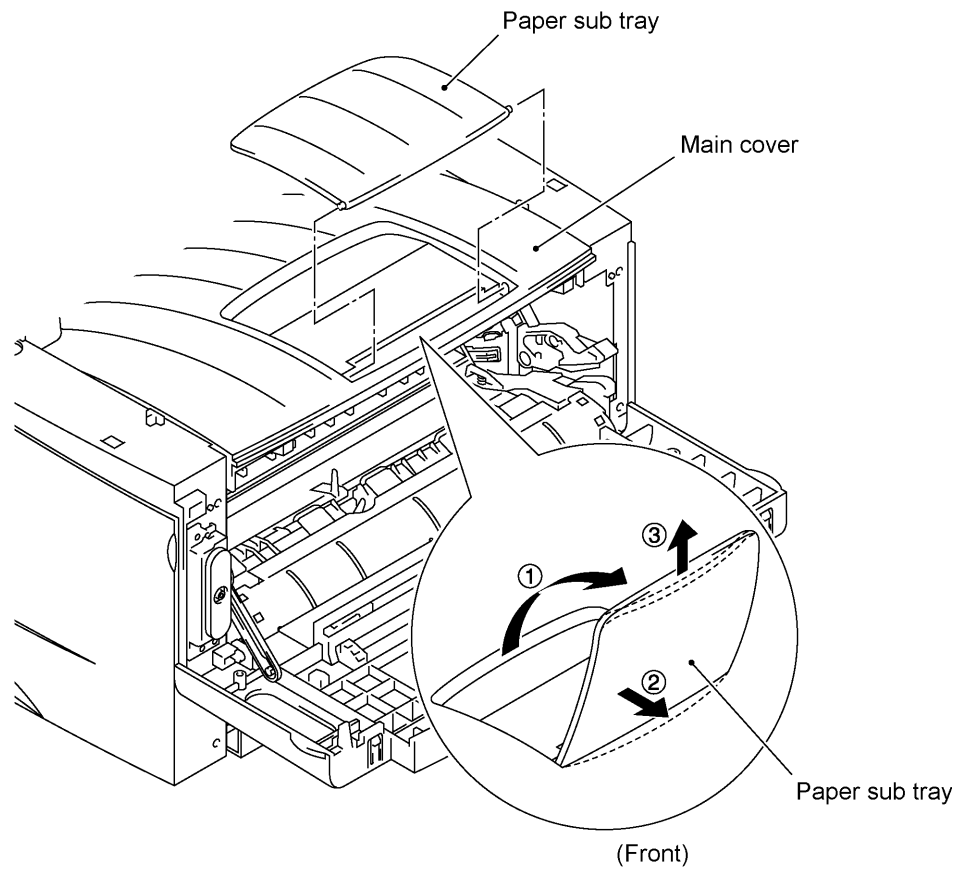



**1.11 VC Cover, VC Bracket, and VC Connector PCB (for models supporting video capture)**

- (1) Remove two screws ("a" and "b"), then take off the VC cover.
- (2) Remove screw "c," take out the VC bracket together with the VC connector PCB, and disconnect the VC harness.
- (3) Remove two screws "d," then take off the VC connector PCB.

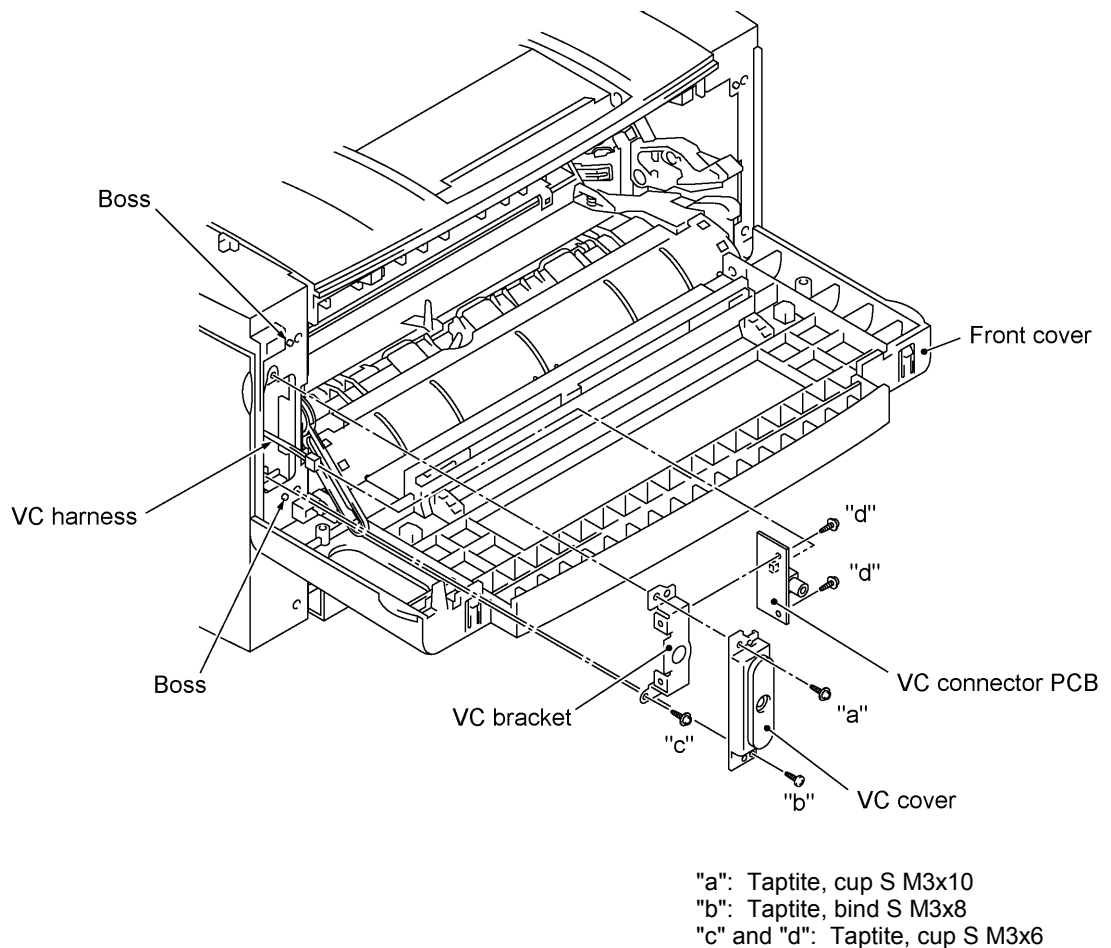

**■ Reassembling Notes**

- The routing of the VC harness is shown on page IV-27.

**1.12 Front Cover**  
**Front Sub Cover (for models not supporting video capture)**

- (1) For models not supporting video capture:  
 Remove the screw and take off the front sub cover from the front cover.

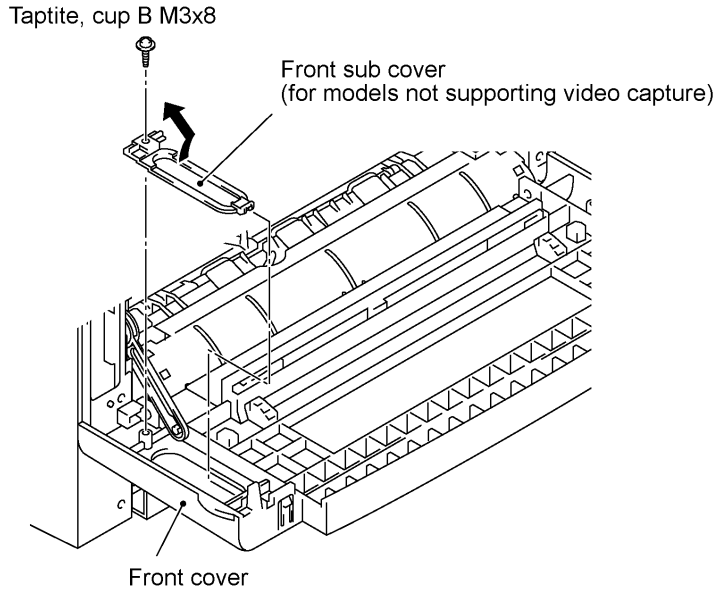

- (2) Remove the screw from the left bottom of the front side of the main cover.  
 (3) Hold the front cover at an angle of 45° and pull the front cover link to the left to release it from the front cover.  
 (4) Pull the bottom left front corner of the main cover to the left (in the direction of arrow ①) and release the front cover from the boss provided on the main cover (arrow ②).

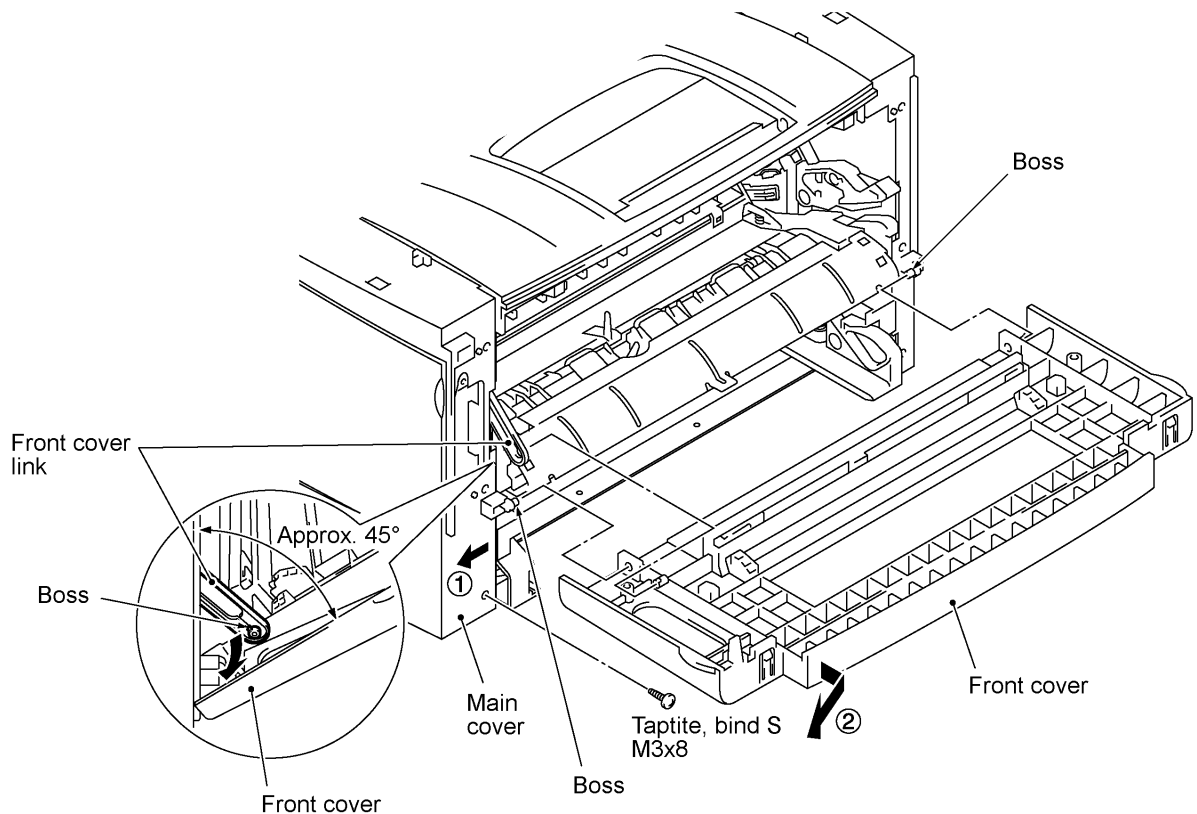

### 1.13 Outer Chute and Paper Pinch Rollers

- (1) Pull up the outer chute and open it (in the direction of arrow ①).
- (2) Remove the chute springs from the hooks provided on the main cover (arrow ②), then lift up the outer chute (arrow ③).

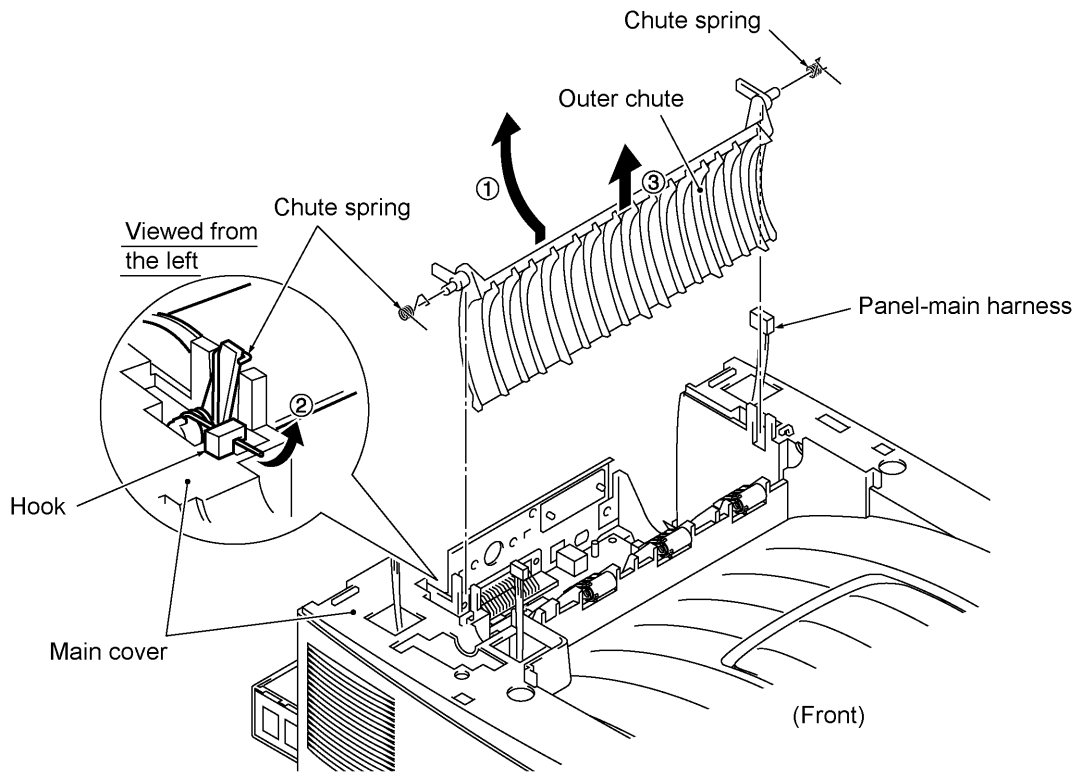

- (3) Remove the paper pinch rollers, their supports, and their springs.

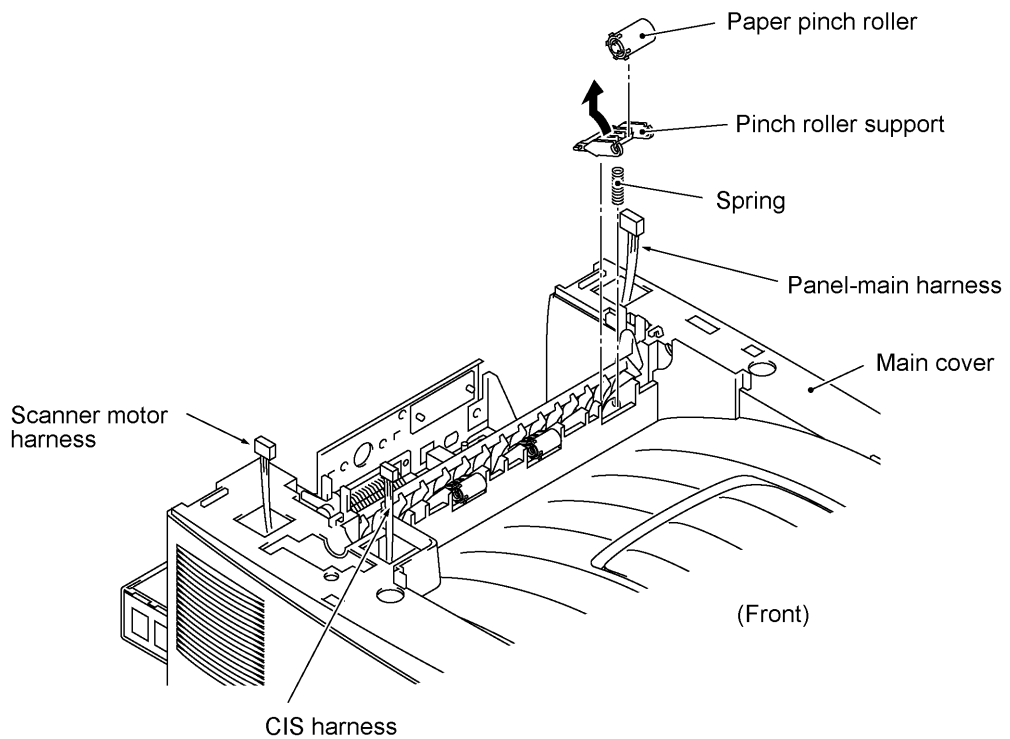

### 1.14 Main Cover

- (1) Remove two screws "a" from the front side of the main cover.
- (2) Remove two screws "b" from the rear side of the main cover, and then pull corner edges "X" outwards to dislocate the main cover from the main chassis. Make sure that the cutout provided in the main cover is dislocated from the power inlet.
- (3) Unhook the two latches with the tip of a flat screwdriver, then lift up the main cover.

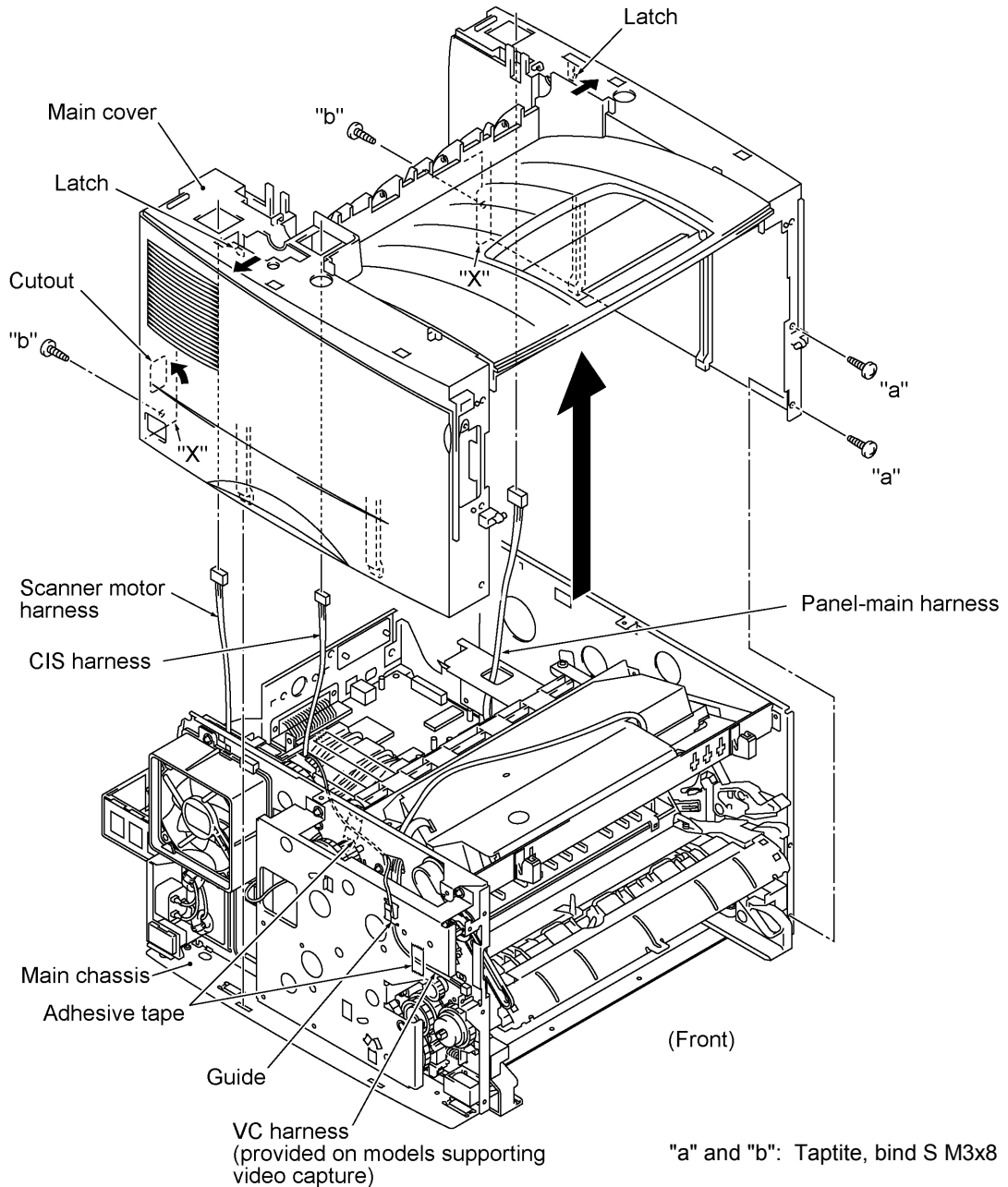

#### ■ Reassembling Notes

- When reinstalling the main cover, route the panel-main harness, CIS harness, and scanner motor harness through the respective cutouts provided in the main cover, as illustrated above.

1.15 Switch Cover

(1) Push the locks of the switch cover as shown below and remove it.

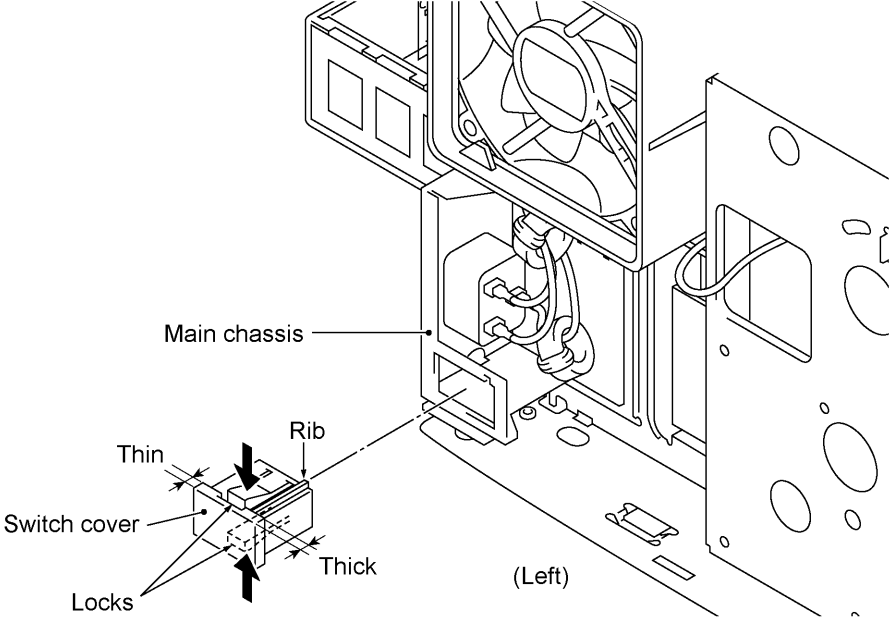

### 1.16 Laser Unit

- (1) Remove screw "a" and take off the harness cover.
- (2) Remove two screws "b."
- (3) Disconnect the polygon motor harness and laser flat cable from the laser unit.
- (4) Lift up the laser unit.

**NOTE:** When handling the laser unit, take care not to touch the inside of the unit, glass, or mirror.

**NOTE:** On the small PCB in the laser unit is a 2-pin connector which is for the adjustment in the factory. Do not disturb it.

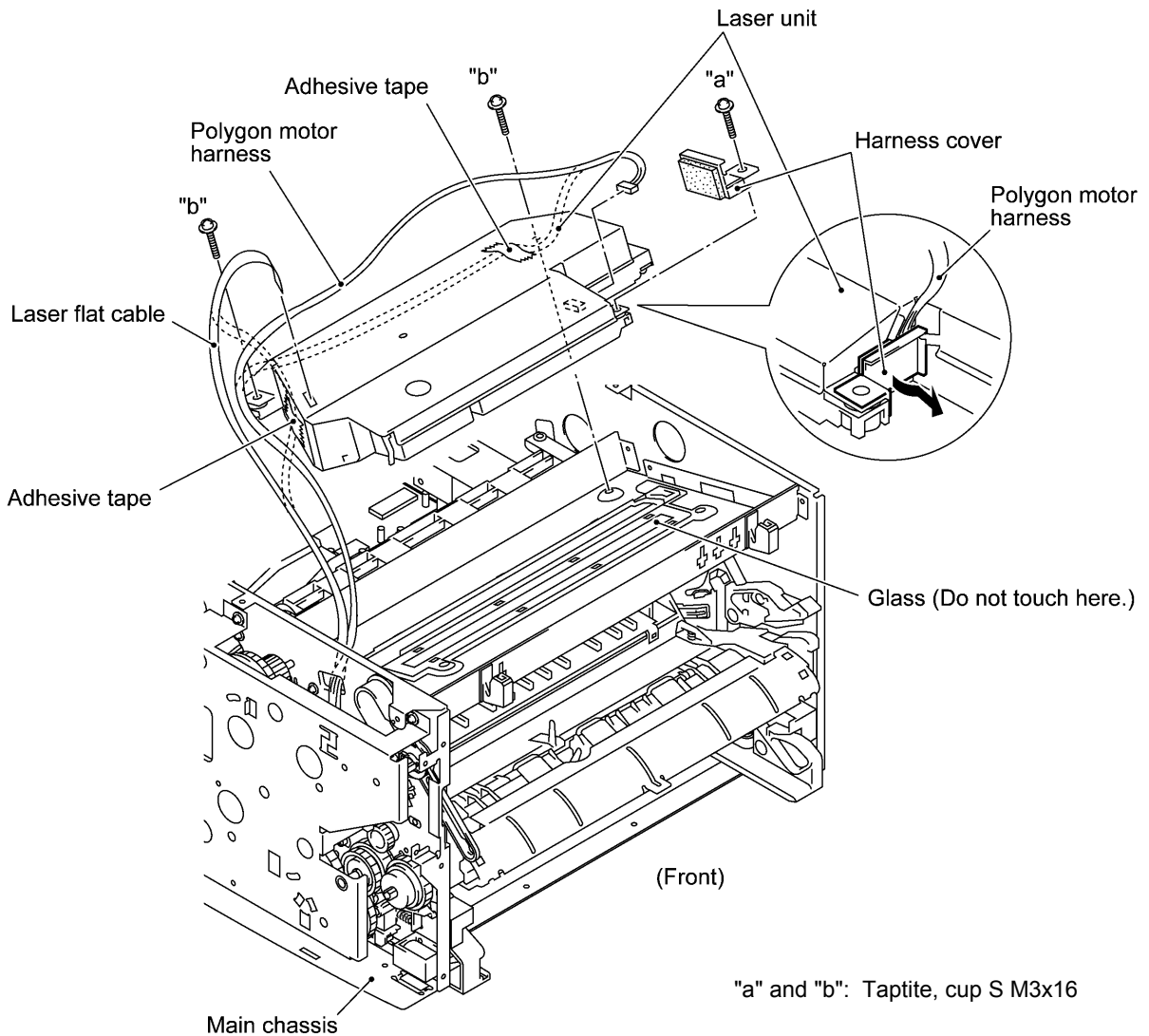

#### ■ Reassembling Notes

- Before putting the laser unit back into place, check for any toner particles, paper dust or dirt, and clean them out.
- After routing the polygon motor harness and laser flat cable, tape them onto the laser unit as shown above.

### 1.17 Heat-fixing Unit and FU Lamp

- (1) Remove the screw from the harness duct.
- (2) Peel off tape and take off the scanner motor harness, CIS harness, and VC harness\* from the harness duct.
- (3) Unhook the harness duct from the main chassis in the directions of arrows ① and ②.

\*Provided on models supporting video capture

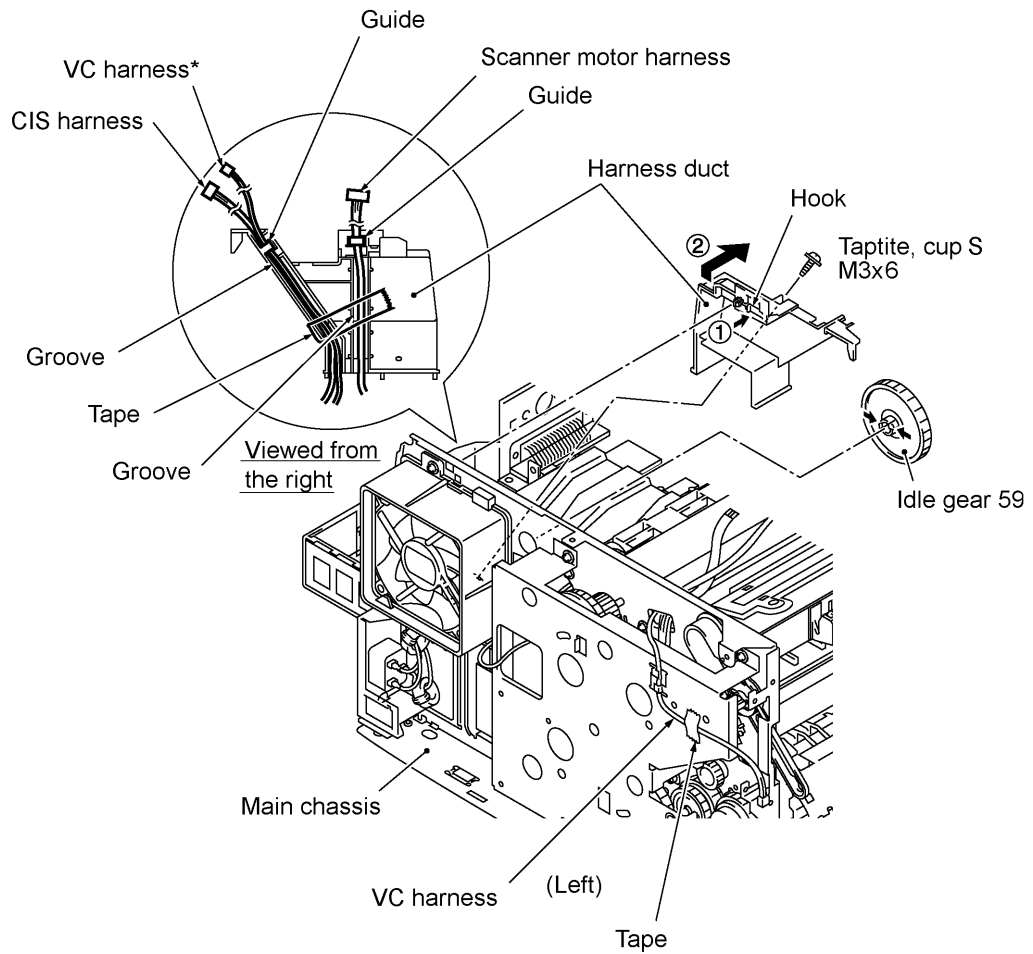

- (4) Remove three screws (two "a" and one "b").
- (5) Disconnect the long heater wire (of the heater harness) from the upper center of the heat-fixing unit.
- (6) Disconnect the short heater wire (of the heater harness) from the left end of the heat-fixing unit.
- (7) Lift up the heat-fixing unit and disconnect the heater thermistor harness from the engine PCB.

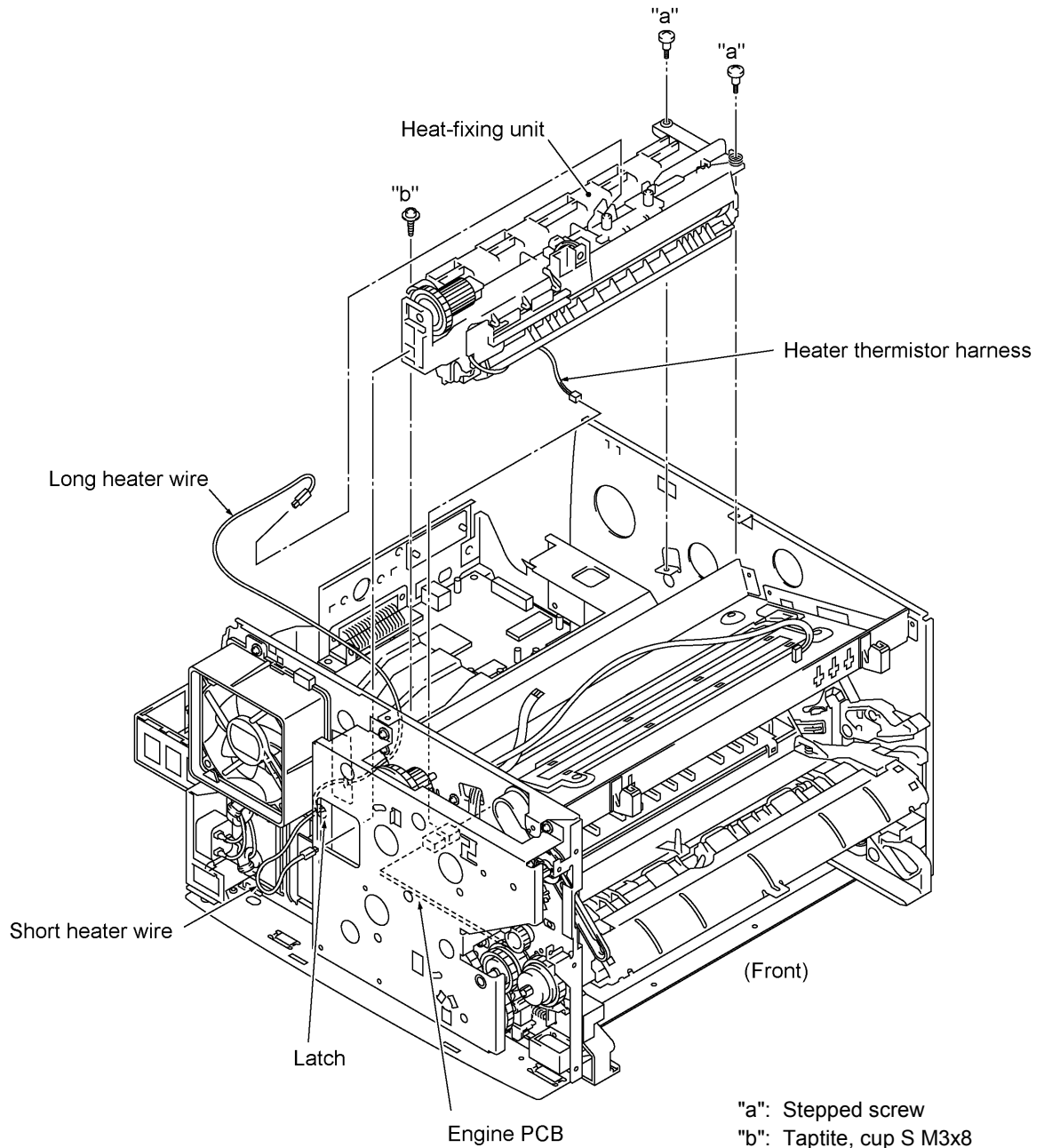



**[Disassembling the heat-fixing unit]**

- (1) Remove the three screws and take off the FU front paper guide.
- (2) Remove the three screws and take off the star wheel holder ASSY.

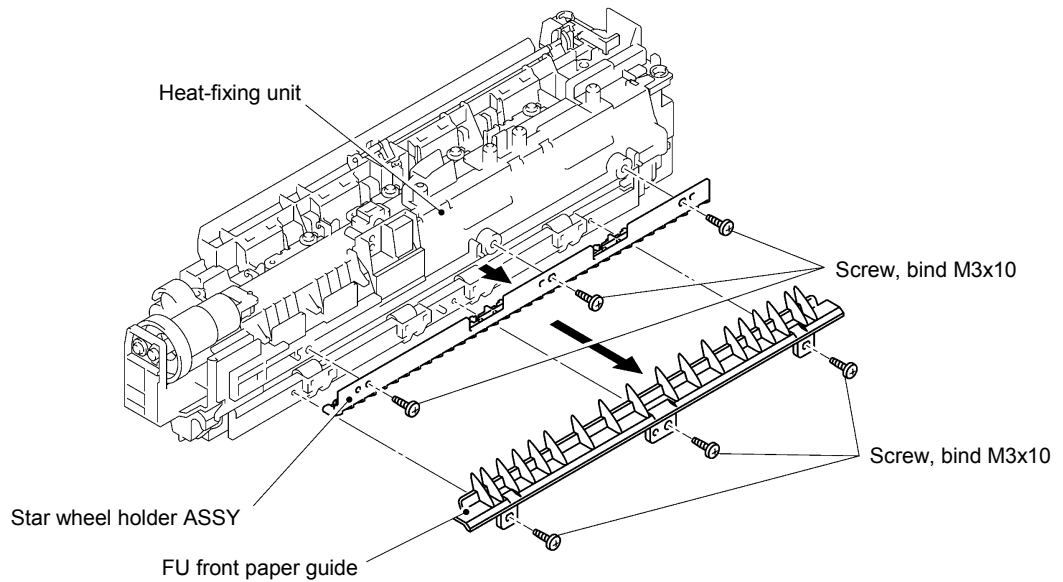

- (3) Release the heater thermistor harness from the three harness guides provided on the underside of the heat-fixing unit.
- (4) Remove the two screws from the top of the heat-fixing unit.
- (5) Unlatch the upper FU frame from the lower one at each of the right and left ends.

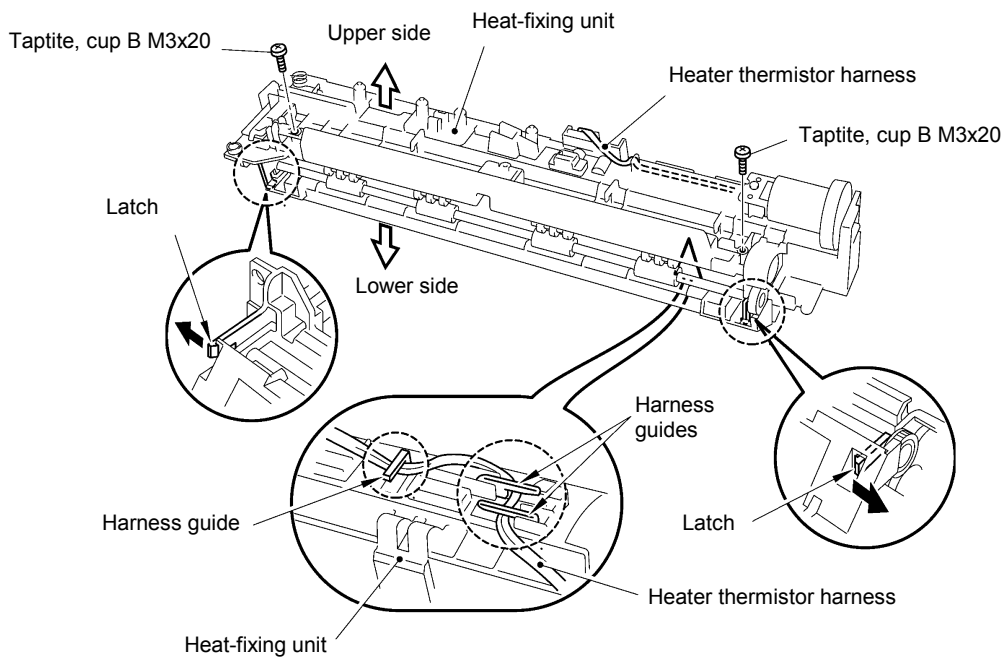

- (6) Separate the lower FU frame from the upper one.

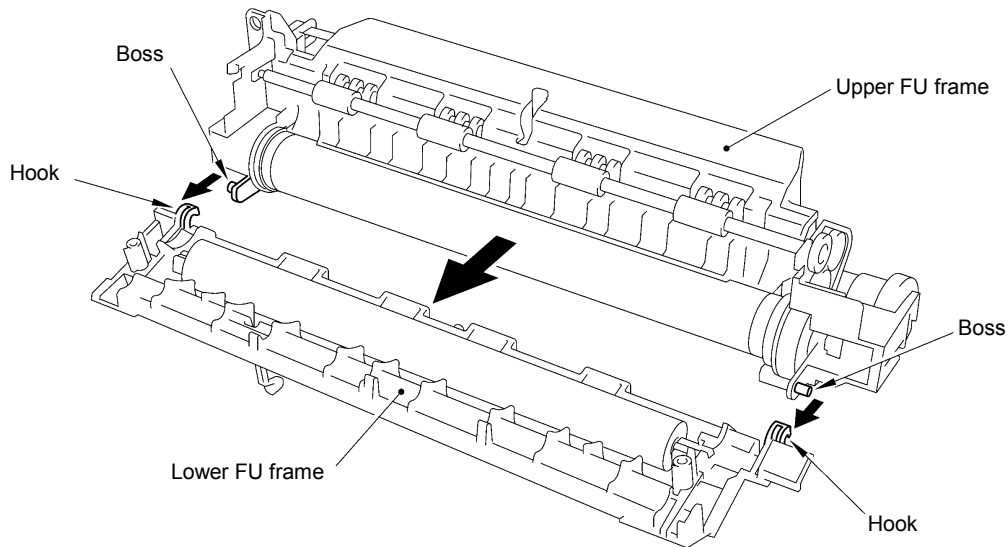

- (7) Remove the screw securing the lamp lock plate at the gear side of the upper FU frame. At the other side, loosen the screw.
- (8) Slightly lift up the right-hand end of the heater roller and pull out the halogen lamp from the heater roller.

**CAUTION:** Do not touch the surface of the halogen lamp. If you have touched it, clean it thoroughly with alcohol.

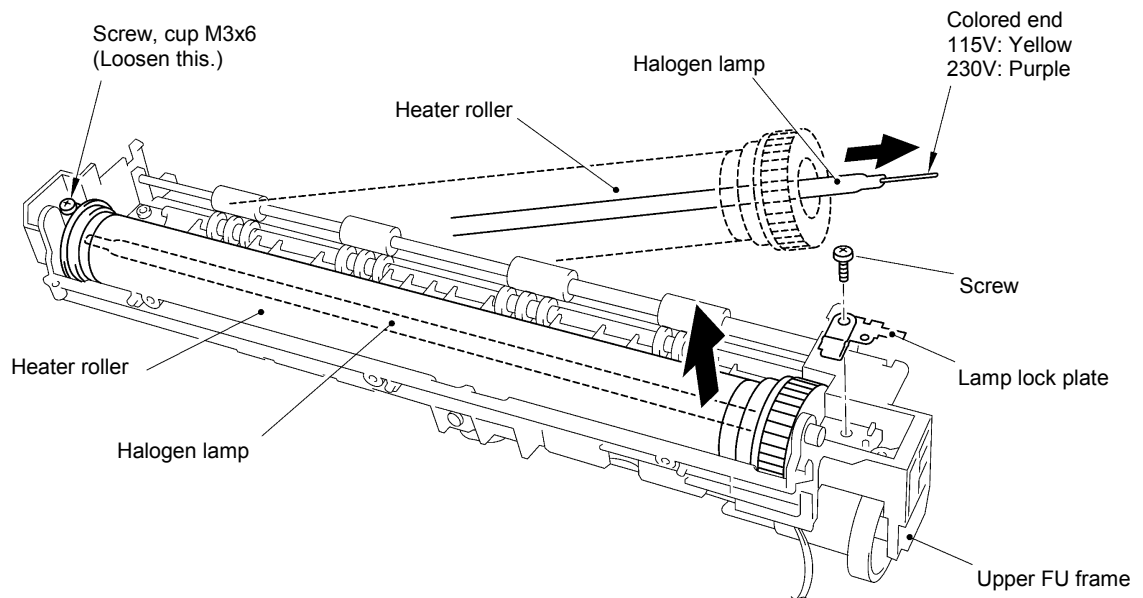

**NOTE:** When setting the halogen lamp into the heat-fixing unit, be careful with the insertion direction as shown above.

**CAUTION:** When securing the halogen lamp to the lamp lock plate with the screw, be sure to use the plastic jig as shown below to avoid damaging the edge of the FU lamp with a screwdriver.

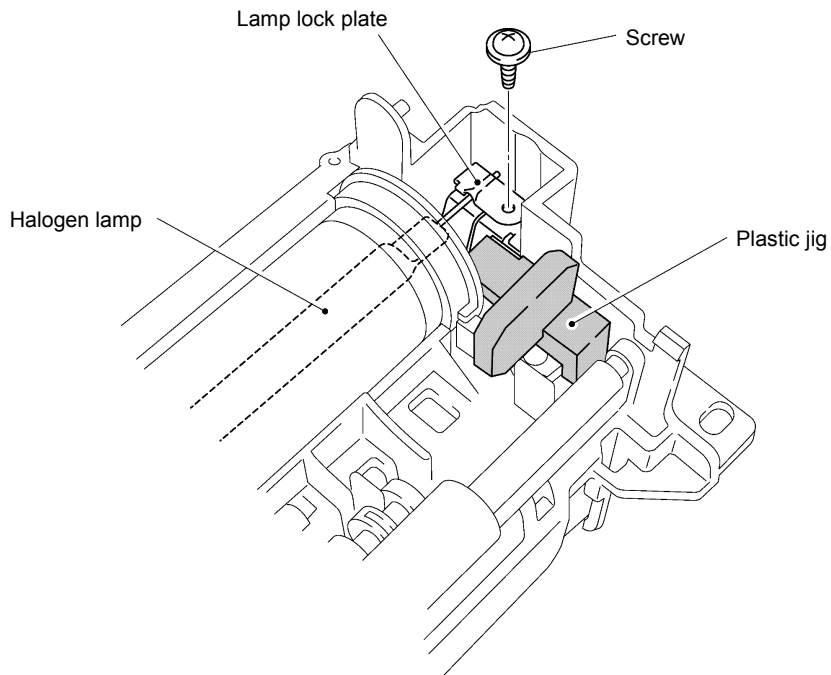

- (9) Take the heater roller out of the upper FU frame.
- (10) At the gear side of the heater roller, remove the HR gear 34, retaining ring 25, washer 25, and bushing 25 in this order.

At the other end of the heater roller, remove the bushing 25.

**CAUTION:** Do not touch the surface of the heater roller. If you have touched it, clean it thoroughly with dry, lint-free cloth.

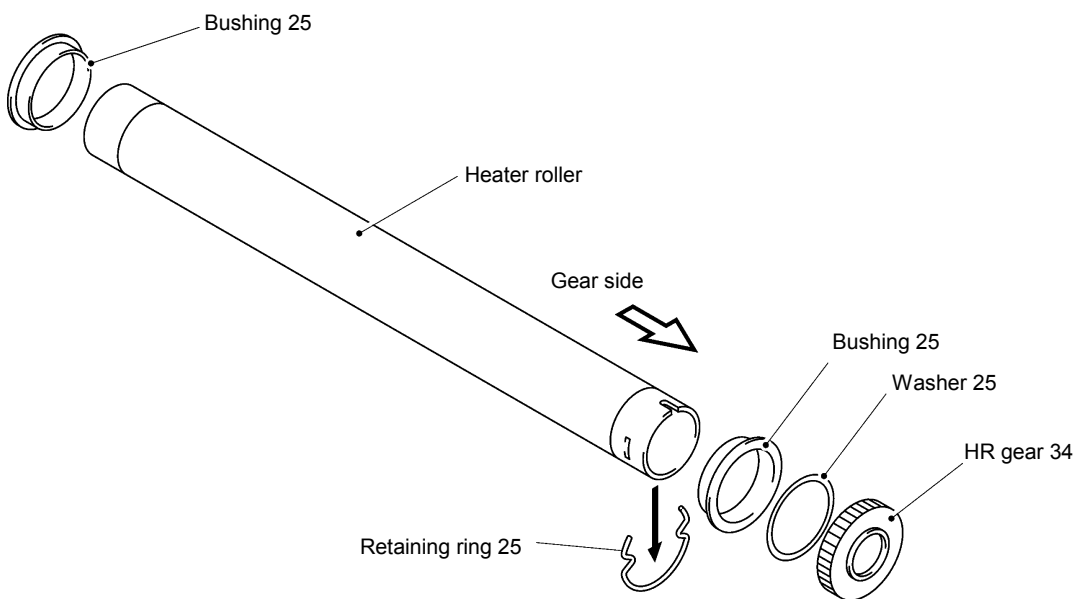

**NOTE:** When setting the heater roller to the upper FU frame, fit the two ribs of the bushing 25 onto the bosses provided on the FU frame as shown below.

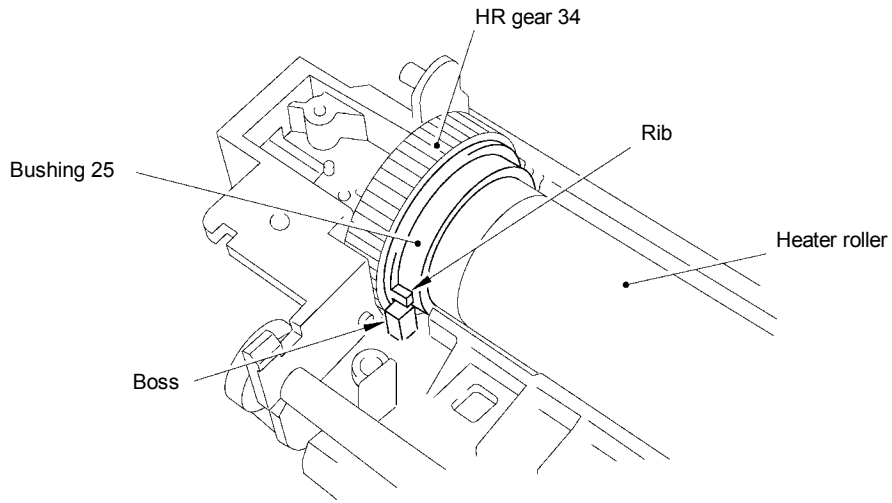

**NOTE:** At the gear side of the heater roller, fit bushing 25 onto the heater roller with the 0.5 mm thick boss facing UP. At the opposite side, fit bushing 25 onto it with the 0.5 mm thick boss facing DOWN.

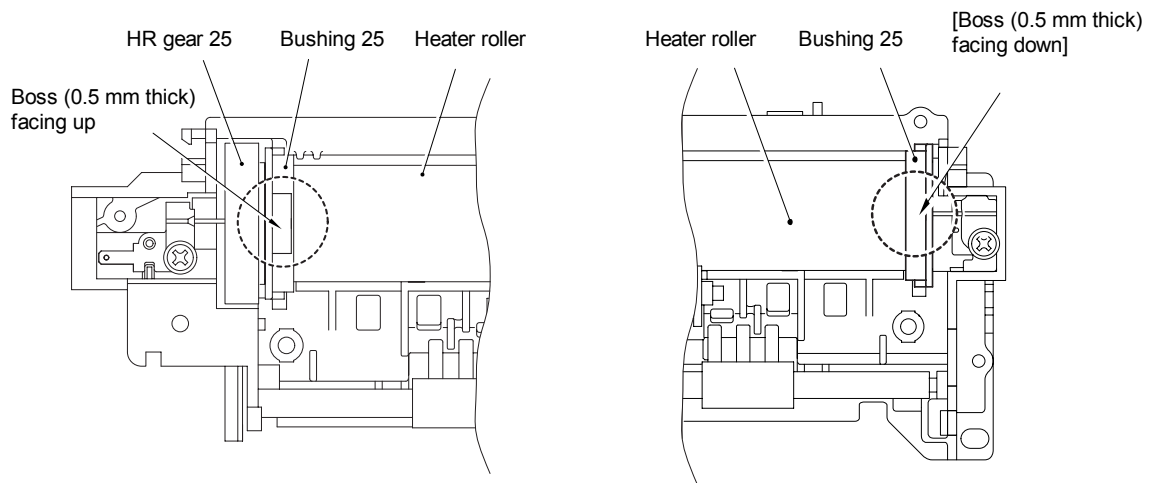

**NOTE:** When setting the heater roller into the upper FU frame, take care not to damage the heater roller with the four hooks.

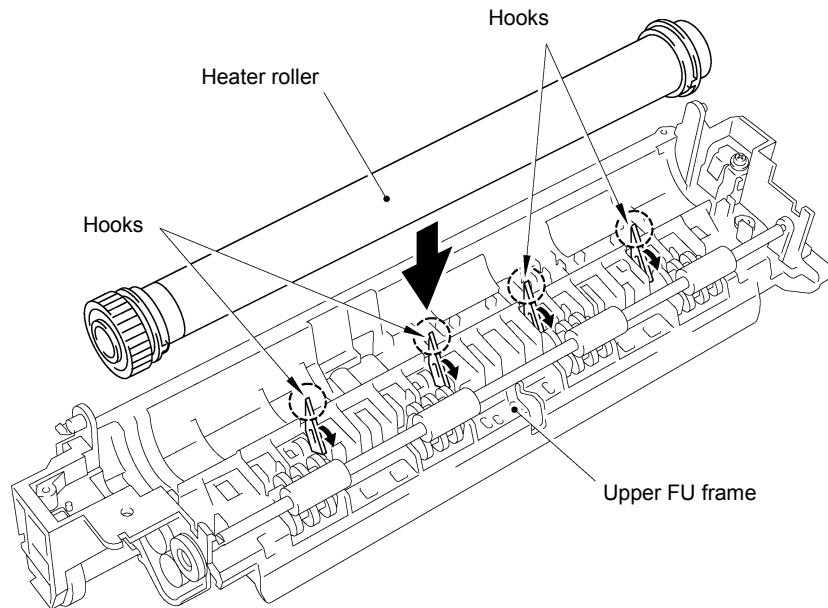

(11) Remove the cleaner ASSY and cleaner spring from the upper FU frame.

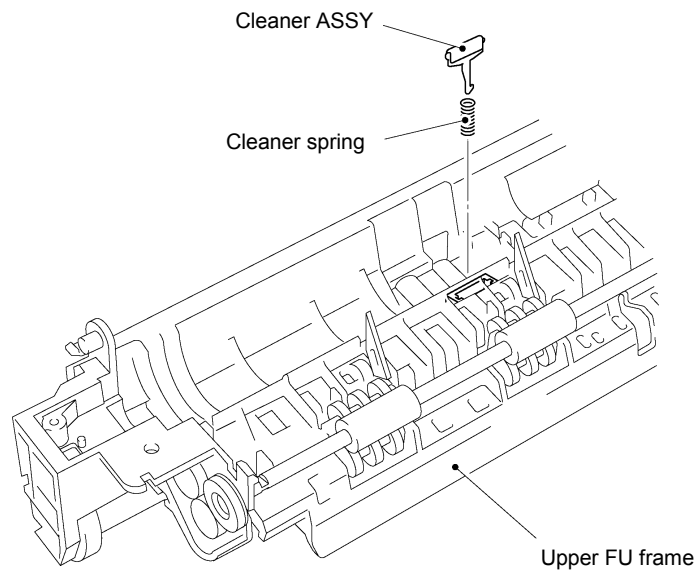

(12) From the lower FU frame, gently lift up the right end of the pressure roller 25 and remove it.

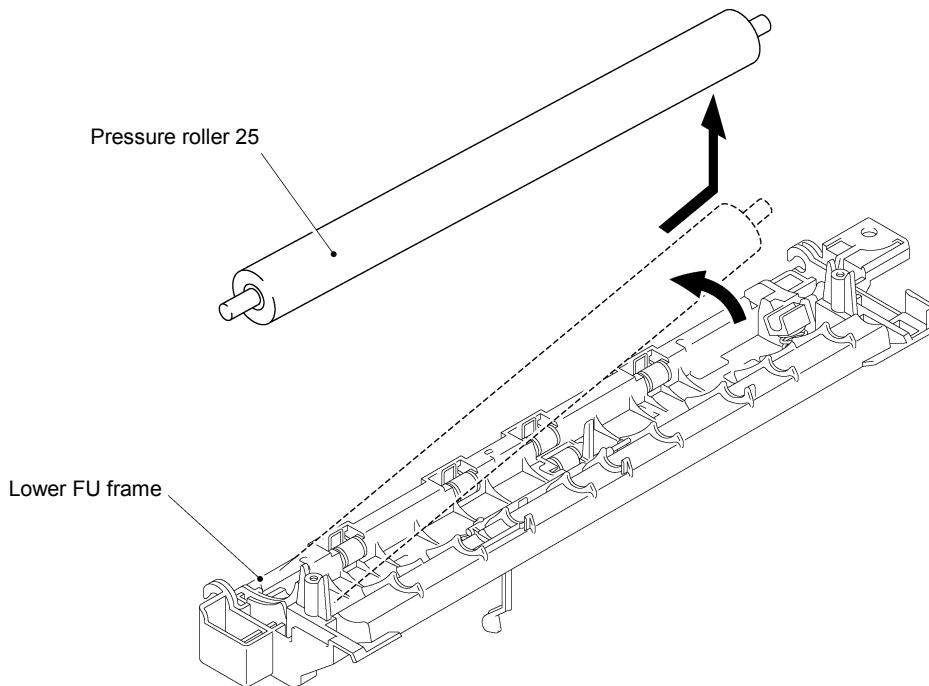

(13) At each of the right and left ends of the lower FU frame, push down the PR bushing to incline it inwards and take it out. Remove the PR springs also.

(14) At each of the four aligned cleaner pinch rollers, pinch section "A" of the claw cleaner spring and pull it up and out of the lower FU frame. Then remove those four cleaner pinch rollers.

(15) At the cleaner pinch roller placed inwards, pinch section "B" of the thermistor cleaner spring and pull it up and out of the lower FU frame.

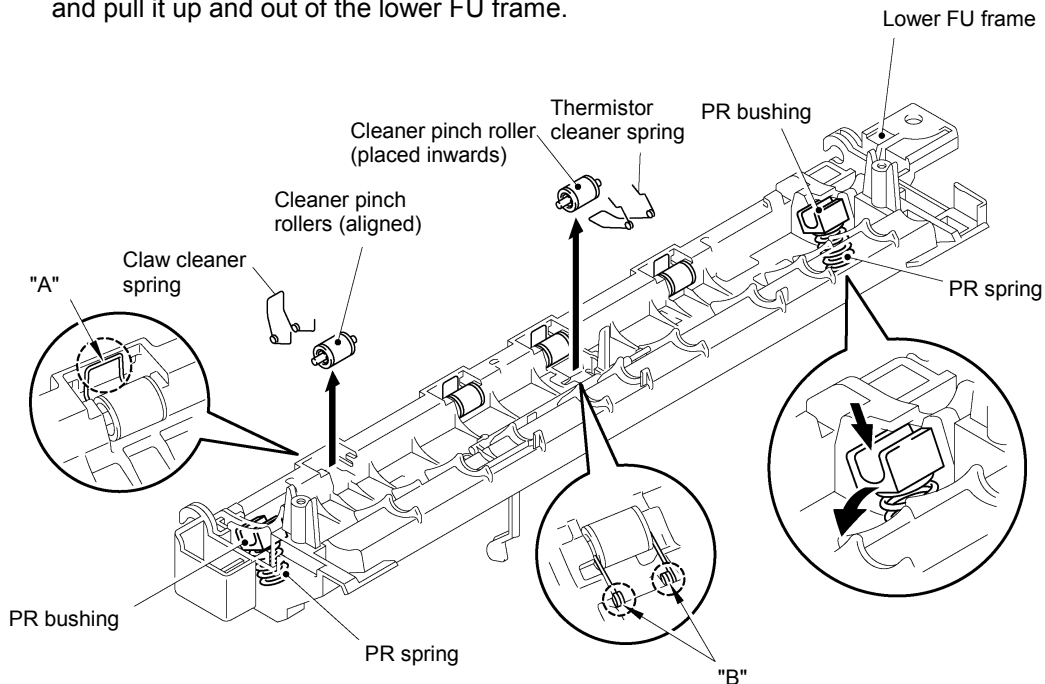

**NOTE:** When setting claw cleaner springs and thermistor cleaner spring into the lower FU frame, fully push them in so that sections A and B will not protrude from the frame.

(16) Release the heater thermistor harness from the harness guides provided on the upper FU frame. Then remove the screw and take off the thermistor.

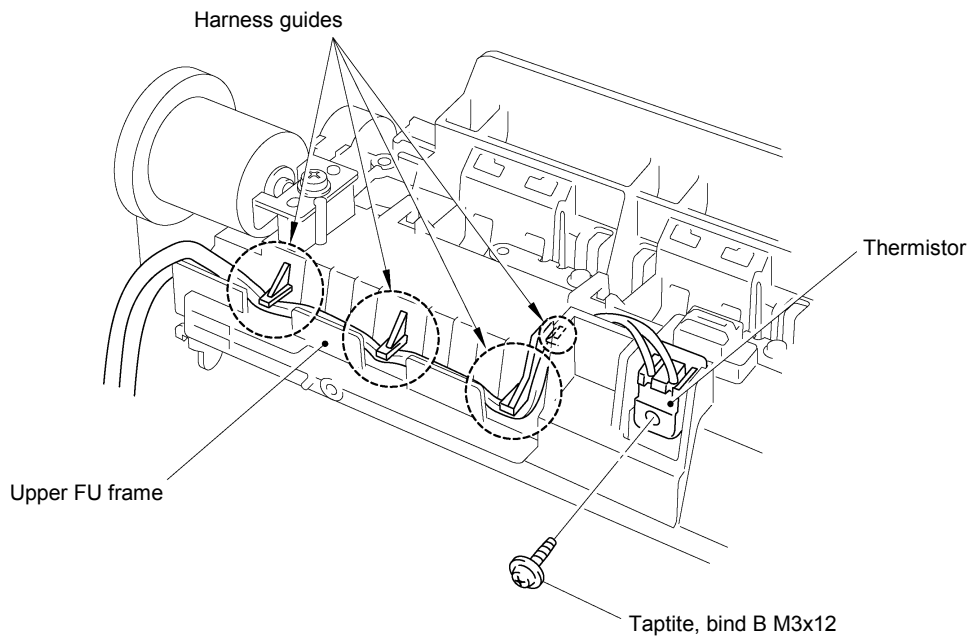

**NOTE:** When setting the thermistor into the upper FU frame, insert it in the direction shown below.

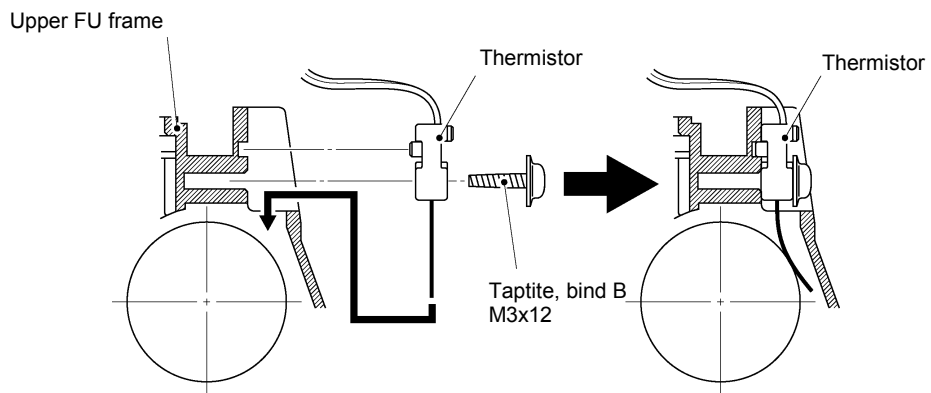

(17) From the upper FU frame, remove the screw and take off the idle gear 13. Then slide the ejection roller to the left and take it out to the front.

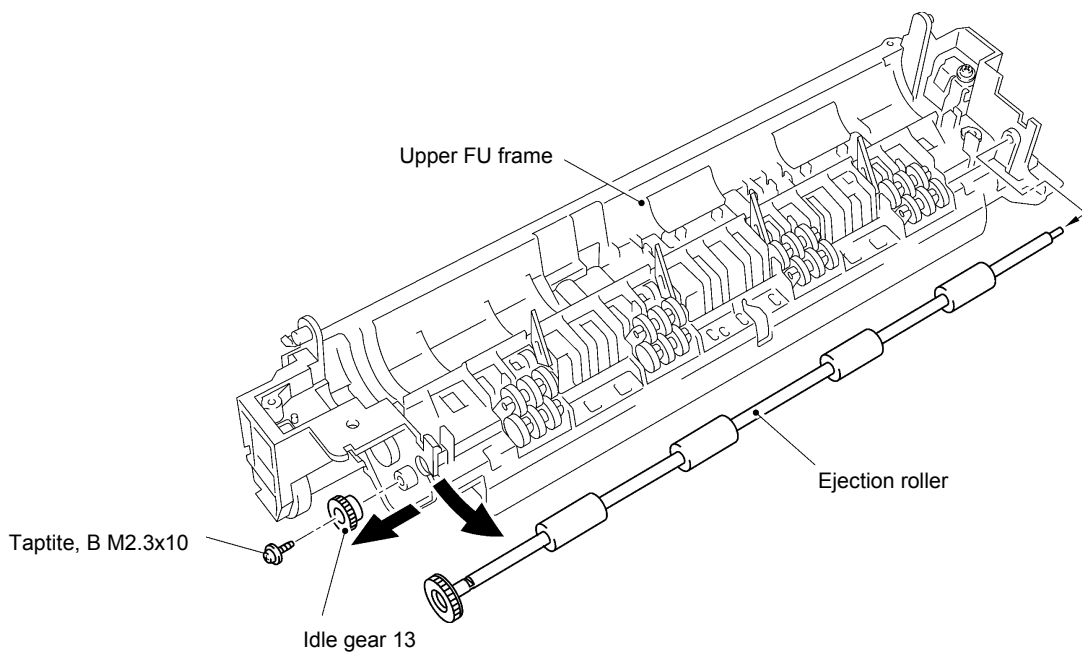

(18) Unlatch each of the four ejection pinch roller holders R and L from the upper FU frame and take it out. Remove the ejection pinch spring from each of those holders.

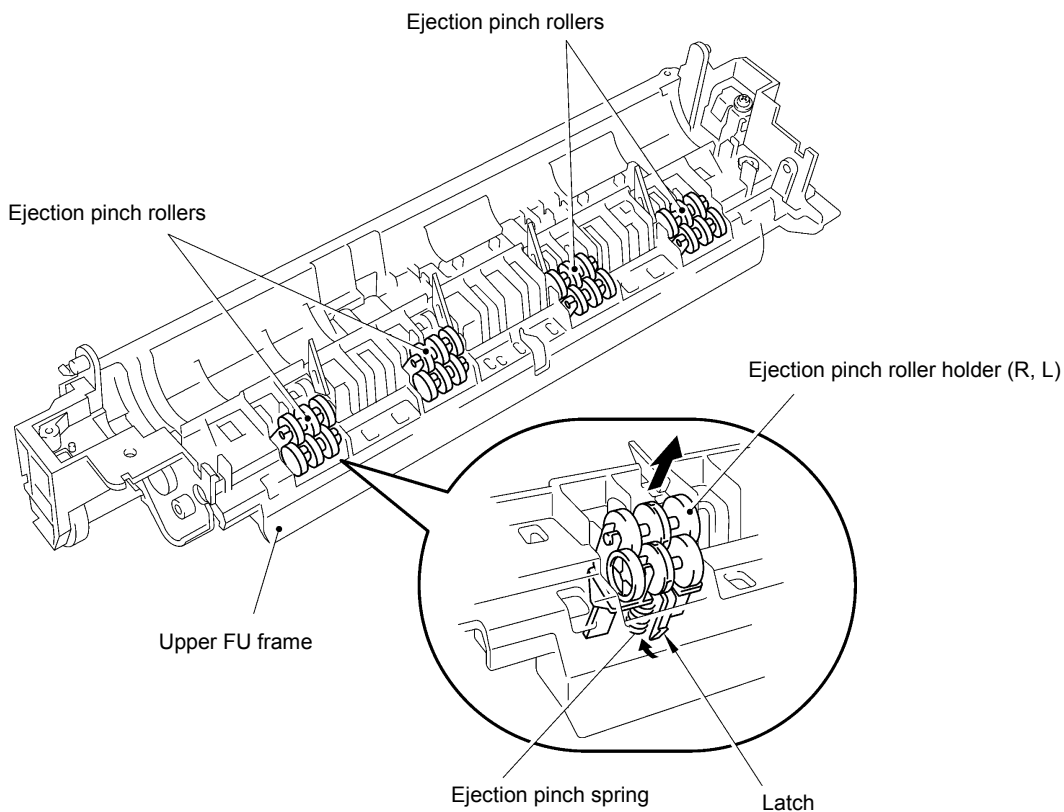



(19) Remove a pair of ejection pinch rollers from each of the ejection pinch roller holders R and L.

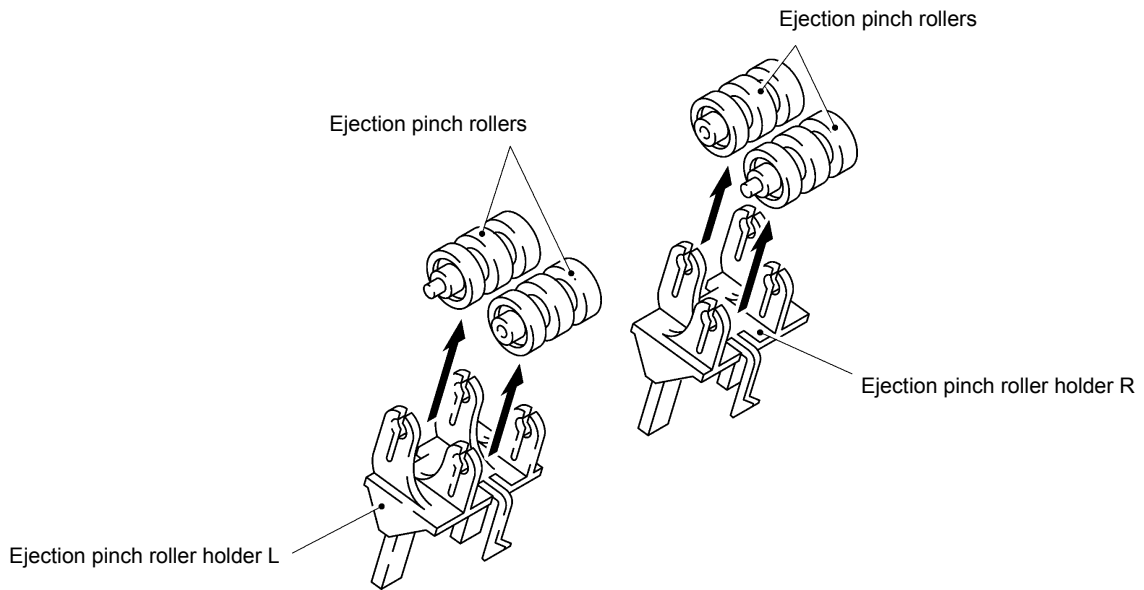

(20) Remove the screw from each of the four claw holder plates and take them off.

Next turn each of the separate claw ASSYs from the bottom to align its cutout with the opening provided in the upper FU frame. Pinch the boss of the separate claw ASSY with tweezers and take it up.

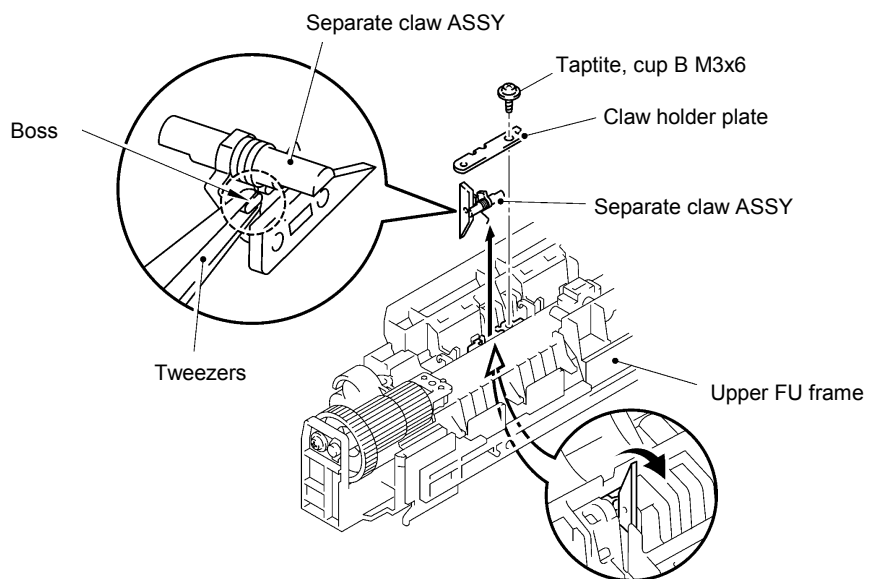

(21) Release the paper ejection sensor actuator from the hook on the lower FU frame and then remove it in the direction of the arrow shown below together with the ejection actuator spring.

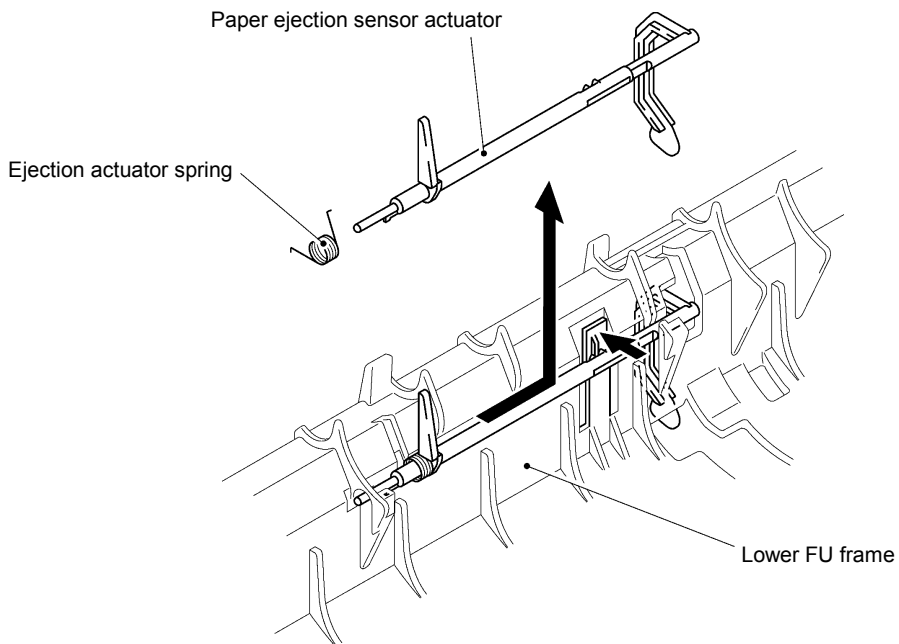

**NOTE:** When setting the paper ejection sensor actuator and its spring, make sure that they are fitted into place as illustrated below.

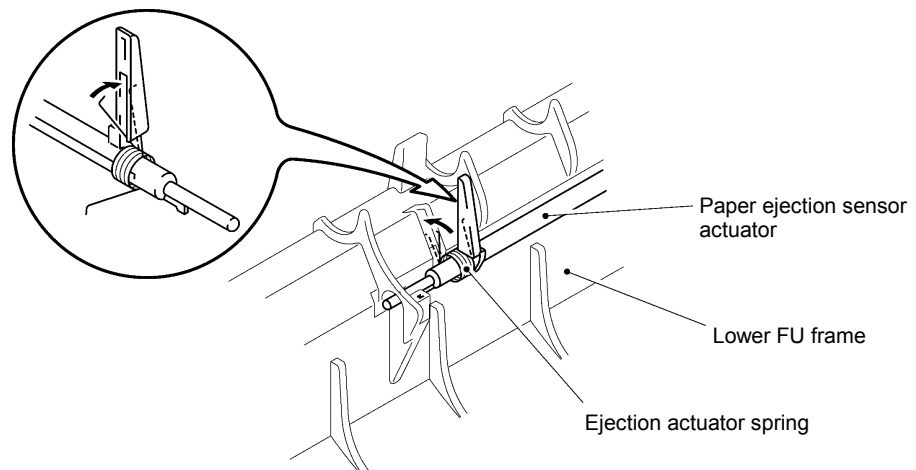

(22) From the upper FU frame, remove the screw, slightly lift up the shutter of the ejection actuator 3, and remove the jam sensor PCB.

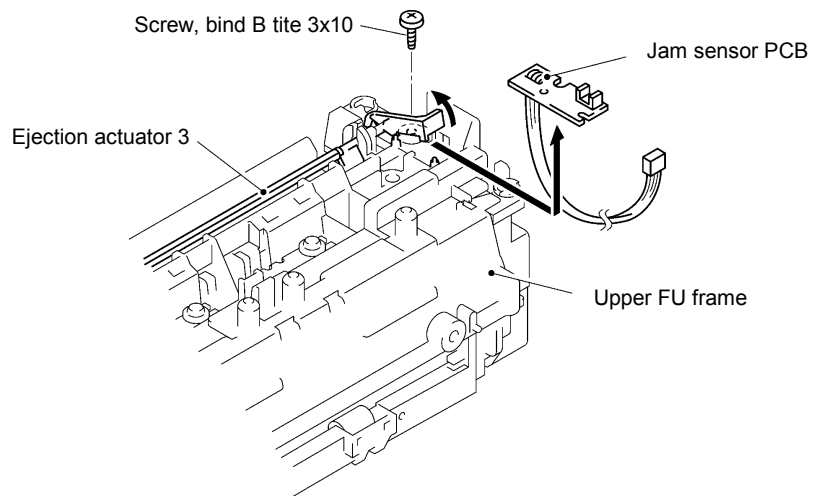

(23) Turn the ejection actuator 3, move it to the right, and lift it up and out of the support.

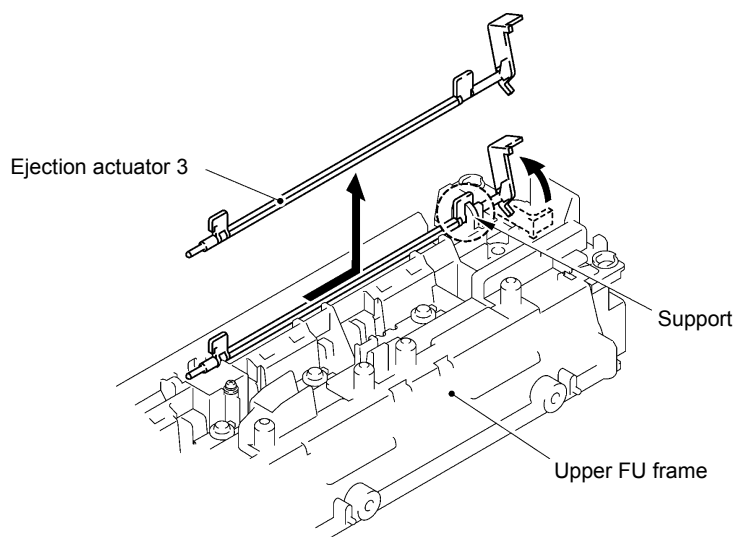

- (24) Remove the screw and take off the actuator holder. Then unhook end "A" of the ejection actuator spring 2 from the upper FU frame and pull up the ejection actuator 2 together with the spring.

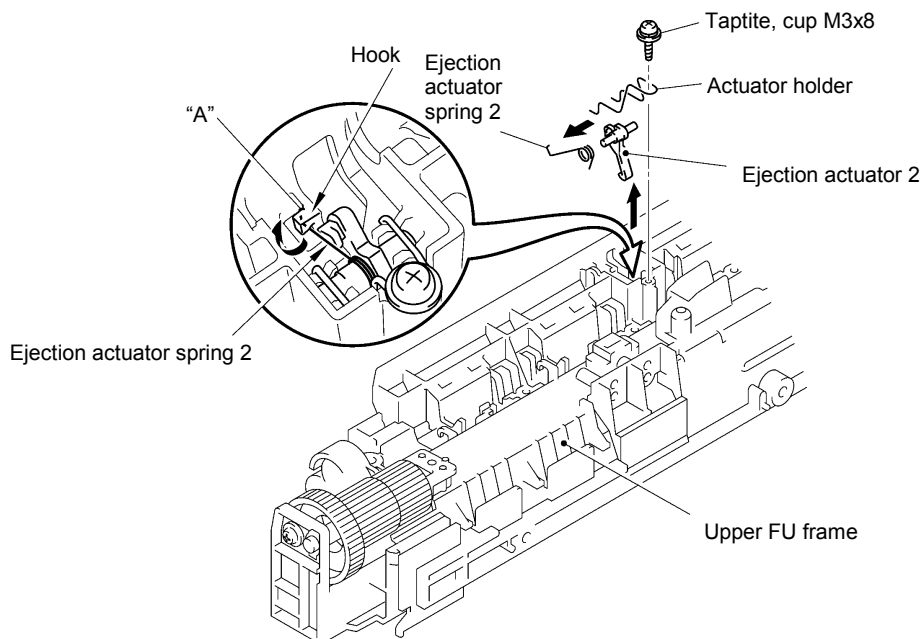

■ **Reassembling Notes**

- A new heat-fixing unit will be provided with the heater thermistor harness being taped to the unit. Before installing the unit, remove the tape.
- If you remove and reinstall the heat-fixing unit because of any failure, make the equipment enter the maintenance mode (by pressing the **Menu**, \* **2**, **8**, **6**, and **4** keys) after completion of reassembly and then make it exit from the mode (by pressing the **9** key twice). Otherwise, the heat-fixing unit may not become energized because of the following reason:

If the failure of the heat-fixing unit is caused by an opening of the thermistor circuit (that senses the temperature of the heat-fixing unit), then the system misinterprets the hot heater as being cold. As a result, the temperature of the heat-fixing unit may become excessively high. To prevent the system from heating the hot heater further at the next powering-on, it is designed so that the heater will not be energized. To cancel this setting, you need to carry out the above maintenance-mode procedure.

1.18 Fan

- (1) Disconnect the fan harness from the engine PCB.
- (2) Remove two screws, take out the heater wires from the latch of the fan duct, and take off the fan duct together with the fan.

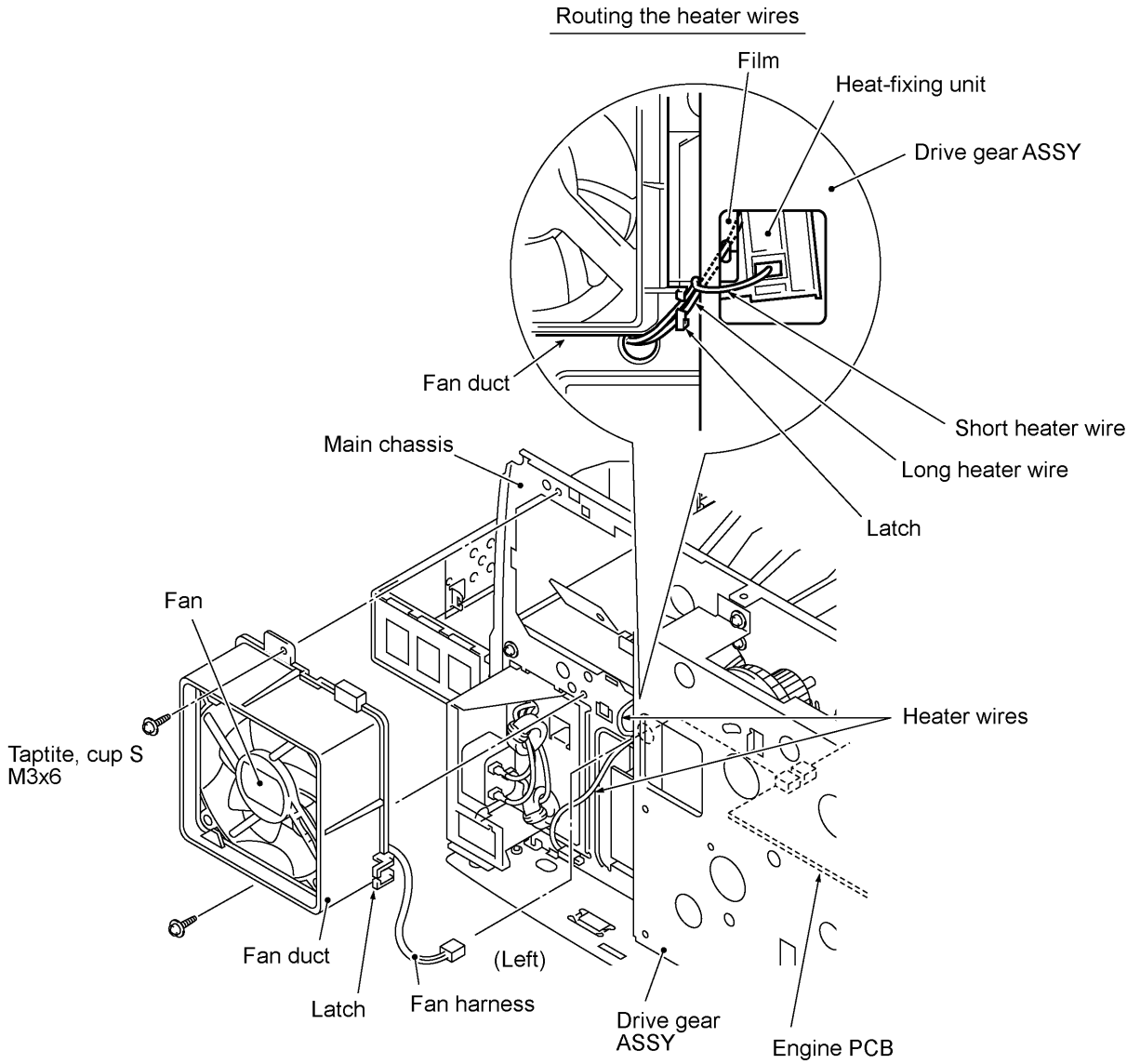

(3) As shown below, pull the fan duct outwards and take out the fan.

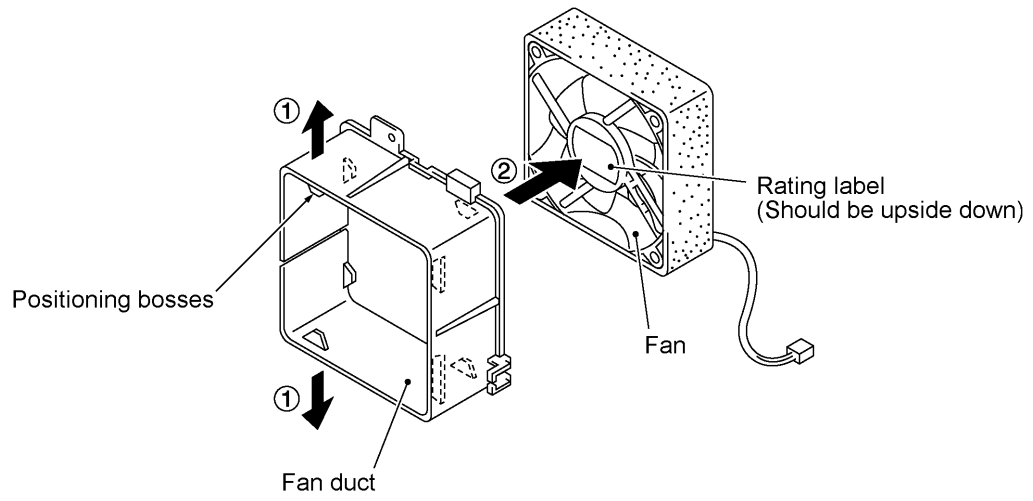

#### ■ Reassembling Notes

- Put the fan back into place so that the rating label faces outwards and upside down.
- Route the heater wires through the latch of the fan duct as shown on the previous page.

**1.19 Drive Gear ASSY and Main Motor ASSY**

- (1) Remove five screws from the drive gear ASSY.
- (2) Tilt the drive gear ASSY towards you while taking care not to drop the develop joint and spring, and then disconnect the main motor harness.
- (3) Remove the front cover link and idle gear 56 from the main chassis.

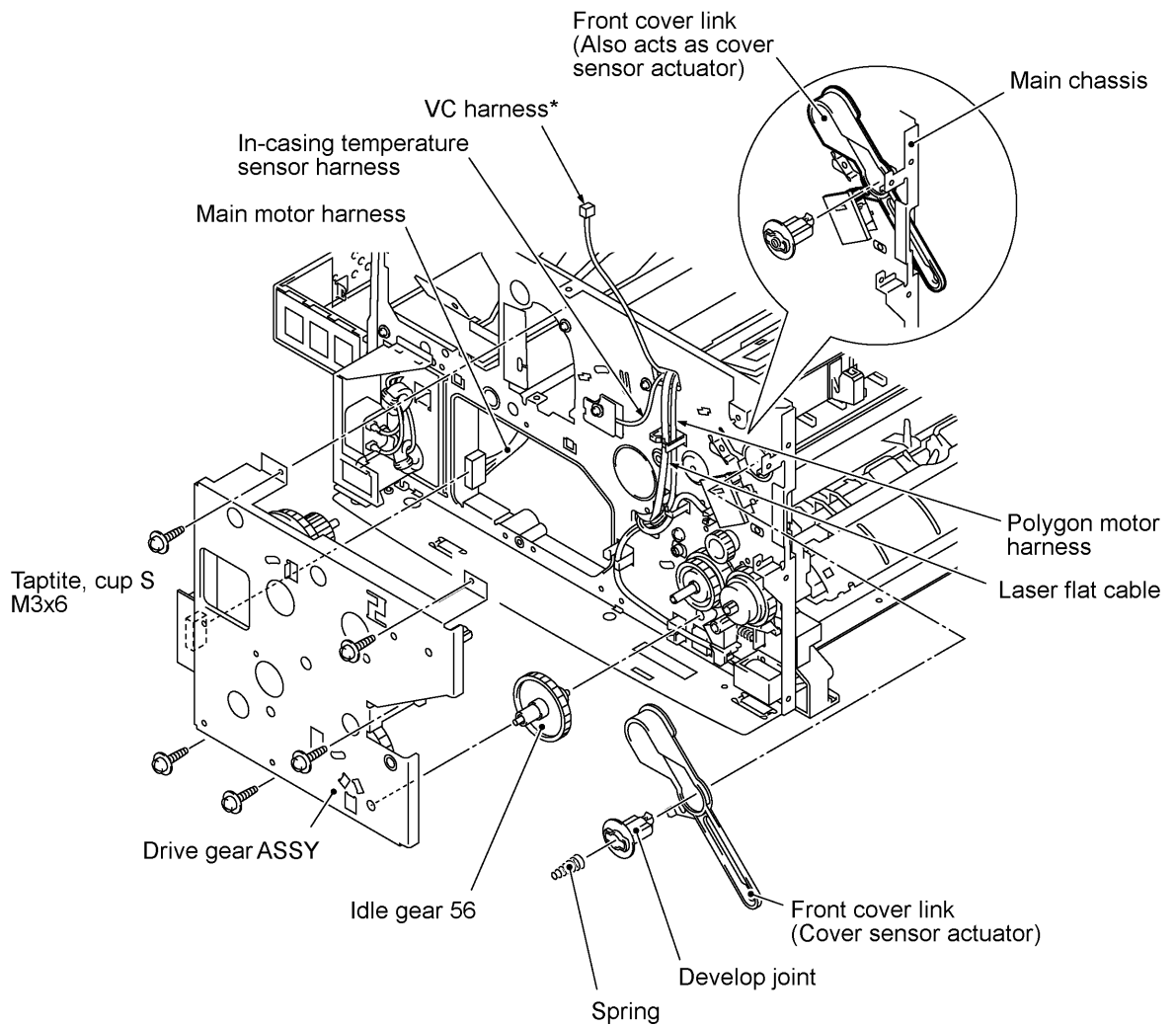

\*Provided on models supporting video capture

- (4) Remove four screws and take off the main motor ASSY from the drive gear ASSY.

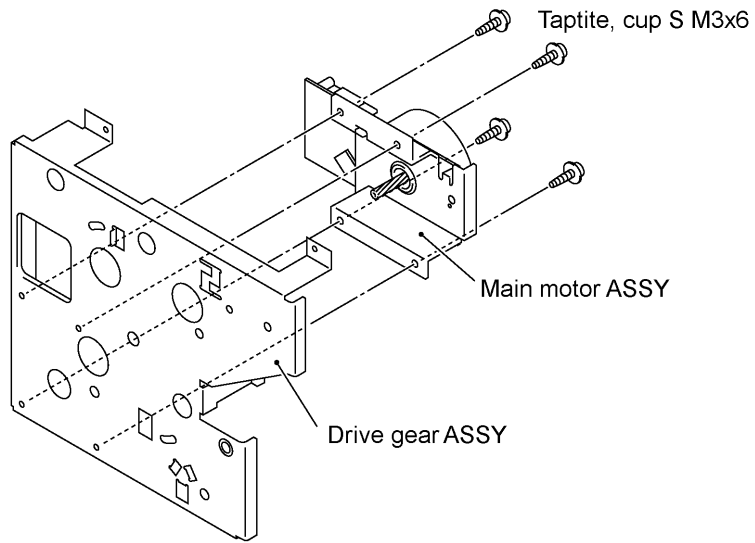

■ **Reassembling Notes**

- If you have removed the gear 39/98 from the drive gear ASSY, hook the spring as shown below.

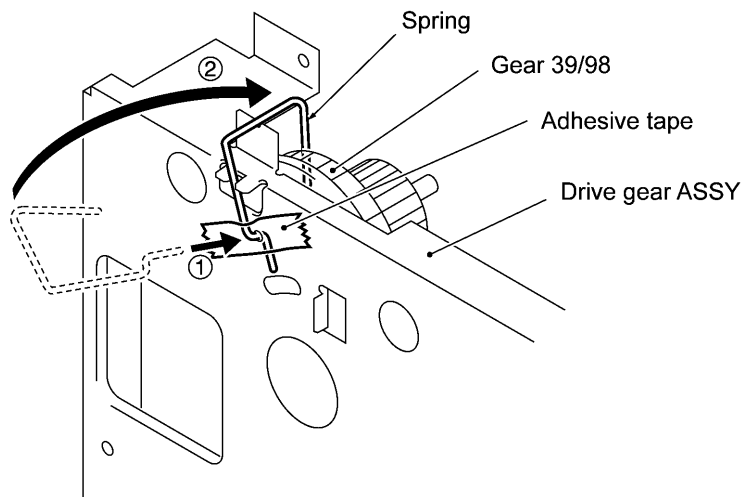



1.20 NCU Shield and NCU PCB

- (1) Remove three screws from the NCU shield, then take off the NCU shield.

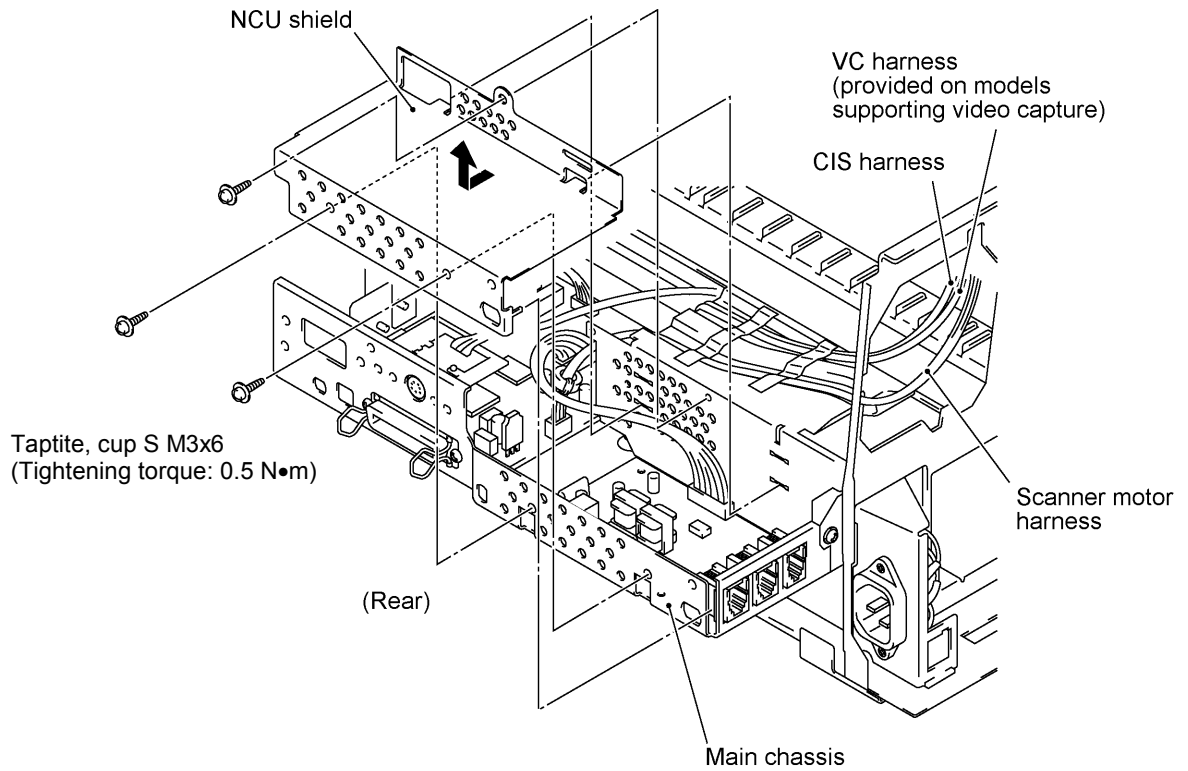

- (2) USA version: Disconnect the main-NCU harness from the main PCB.  
 European version: Disconnect the main-NCU harness and main-NCU harness 2 from the main PCB. See the illustration given on the next page.
- (3) Remove the screw from the NCU PCB and take out the PCB.

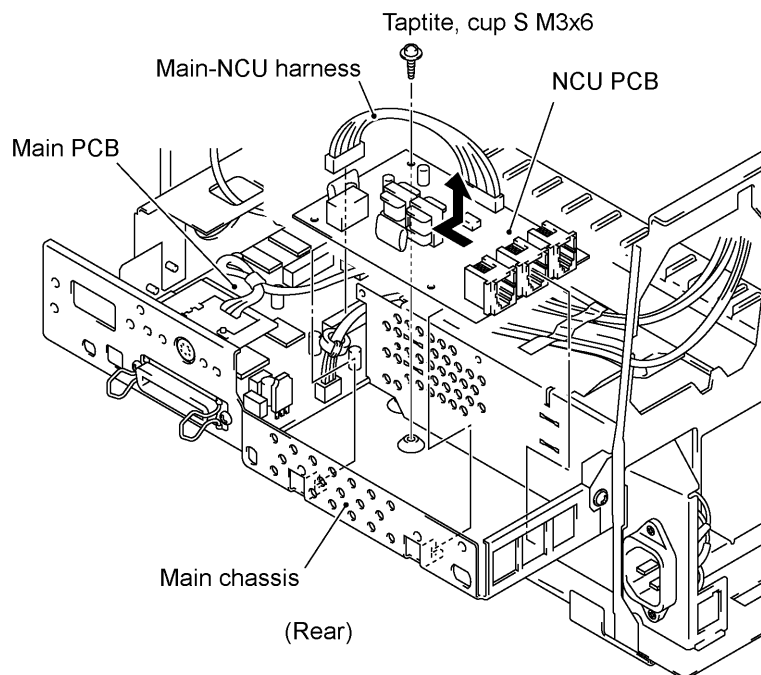

■ **Reassembling Notes**

[USA version]

- Route the main-NCU harness above the scanner motor harness as illustrated below.

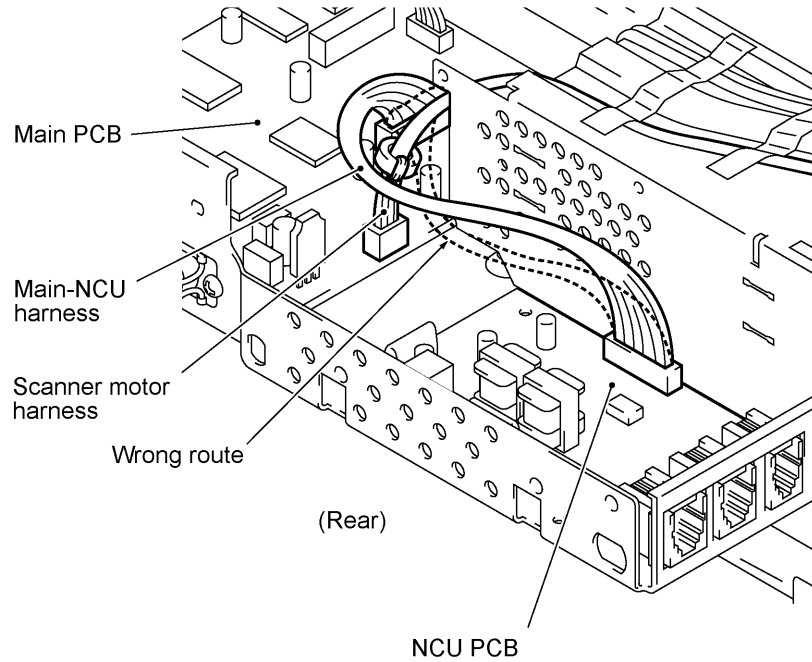

[European version]

- As illustrated below, route the main-NCU harness and main-NCU harness 2 between the NCU PCB and the power supply bracket to prevent them from interfering with the primary circuitry on the NCU PCB. Then install the NCU shield.

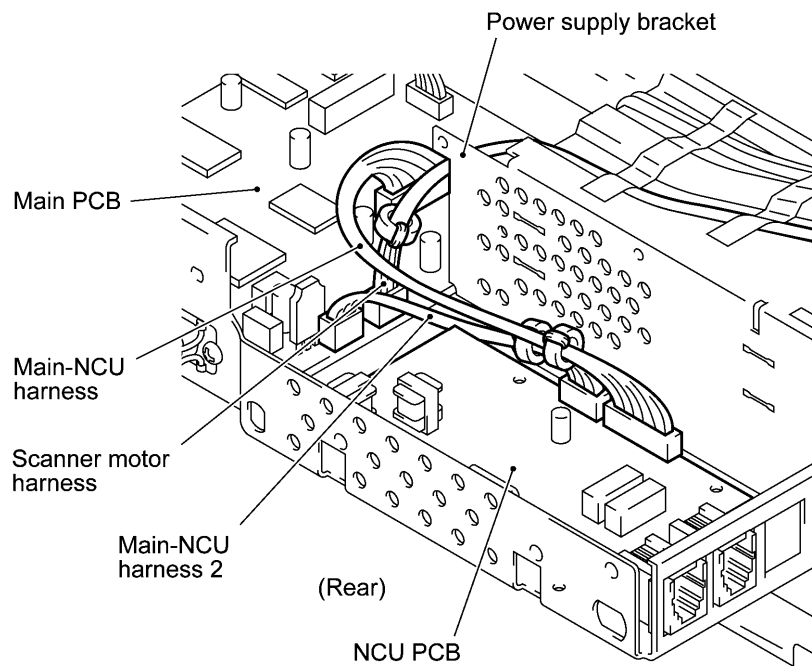

1.21 Bottom Plate, Main PCB, and Bottom Insulation Film

(1) Disconnect the following harnesses and flat cable from the main PCB:

- Panel-main harness (6-pin, P3)
- Main-LV-engine harness (6-pin, P22)
- Laser flat cable (P9)
- Engine-main harness (12-pin, P8)
- VC harness\*<sup>1</sup> (2-pin, P11)
- CIS harness (7-pin, P12)
- In-casing temperature sensor harness (2-pin, P13)
- Scanner motor harness (4-pin, P14)

\*<sup>1</sup> Provided on models supporting video capture  
 \*<sup>2</sup> Provided on models equipped with a handset  
 \*<sup>3</sup> Provided on the European version

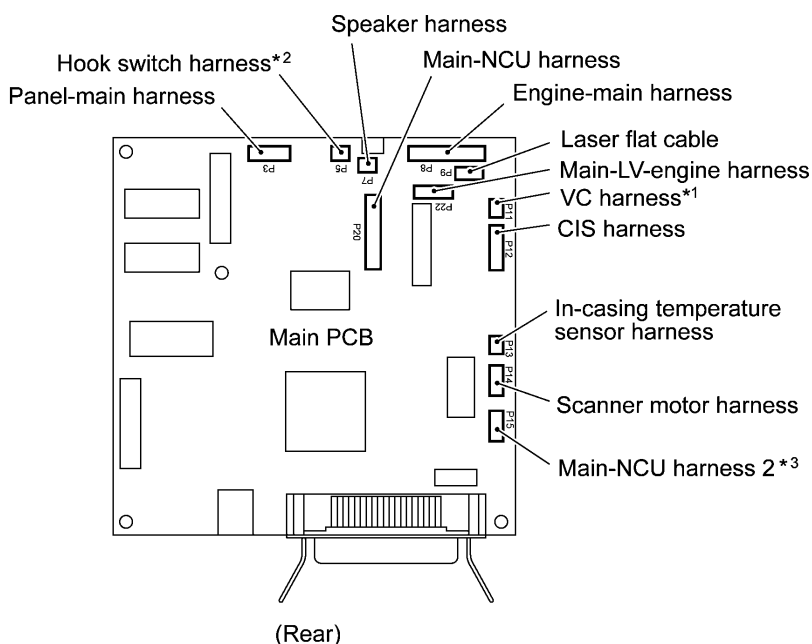
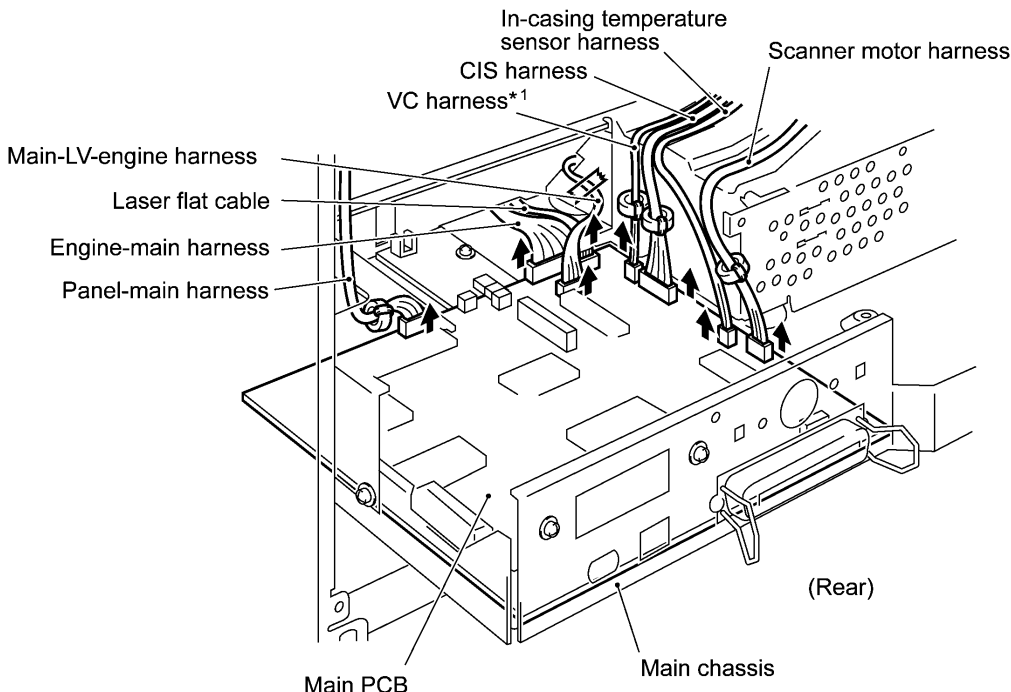

- (2) Turn the main chassis upside down.
- (3) Remove 14 screws (nine "a" and five "b").
- (4) Slightly lift up the bottom plate and pull it to the rear until you can remove screw "c."
- (5) Remove screw "c" to release the grounding wire.
- (6) For models available with a 2nd paper cassette: Unhook the 2nd cassette relay PCB bracket from the bottom plate.
- (7) Pull the bottom plate to the rear and out of the main chassis.

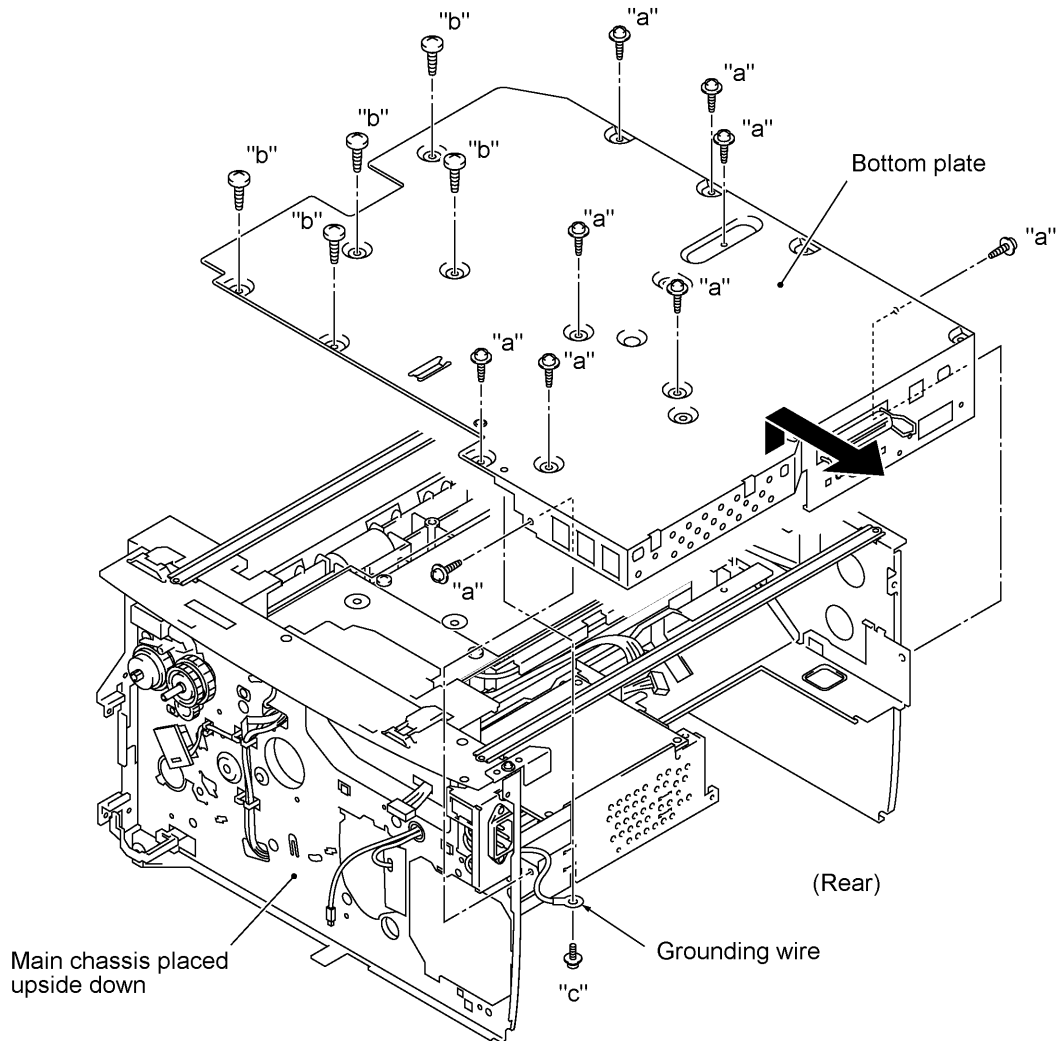

"a": Taptite cup S M3x6  
 "b": Taptite, blind B M4x12  
 "c": Screw, pan (washer) M3.5x6

- (8) Remove screw "d" and disconnect the paper ejection sensor PCB from the main PCB.
- (9) Remove five screws (three "e" and two "f"), then take off the main PCB from the bottom plate.
- (10) Remove the bottom insulation film.

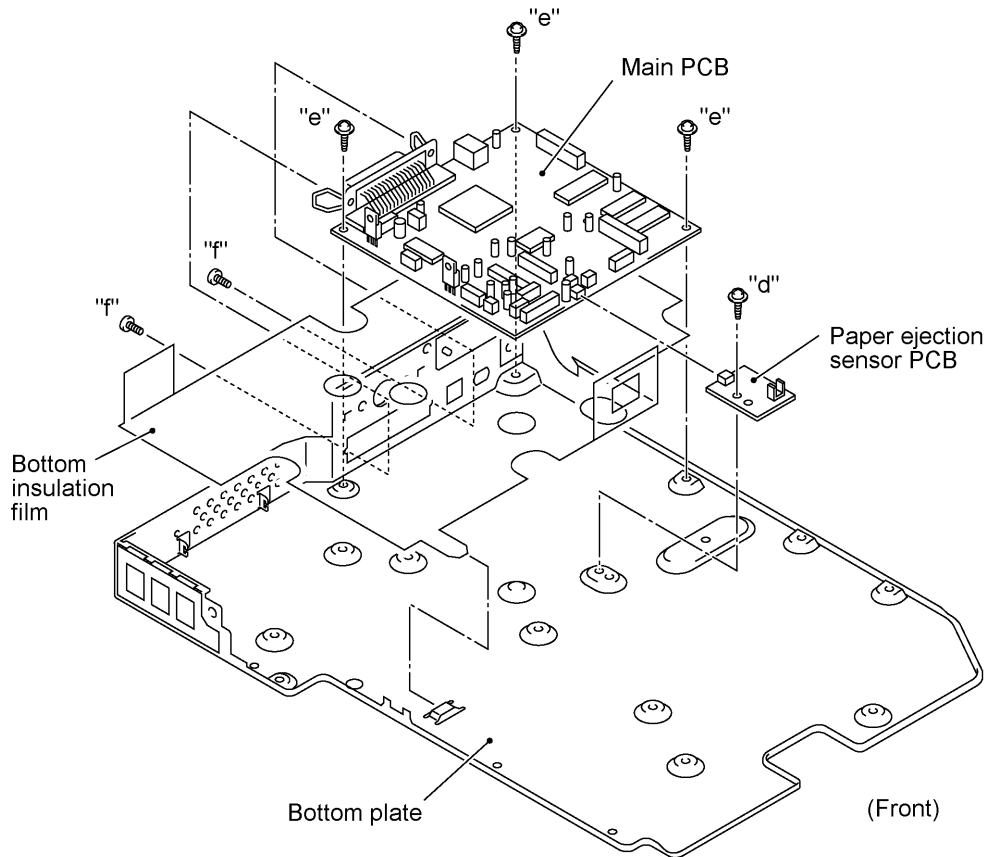

"d" and "e": Taptite, cup S M3x6  
 "f": Machine screw, pan M3x6

#### ■ Reassembling Notes

- When putting the bottom plate back into place, make sure that the grounding wire is looped and routed through the support film (as illustrated on page IV-54) and then secure the grounding wire to the bottom plate with screw "c" (shown on the previous page).
- When connecting the engine-main harness, laser flat cable, and main-LV-engine harness to the main PCB, prevent them from interfering with each other in the vicinity of the connectors.
- After you replace the main PCB, be sure to follow the flowchart given on the next page.

**Setting up the main PCB after replacement**

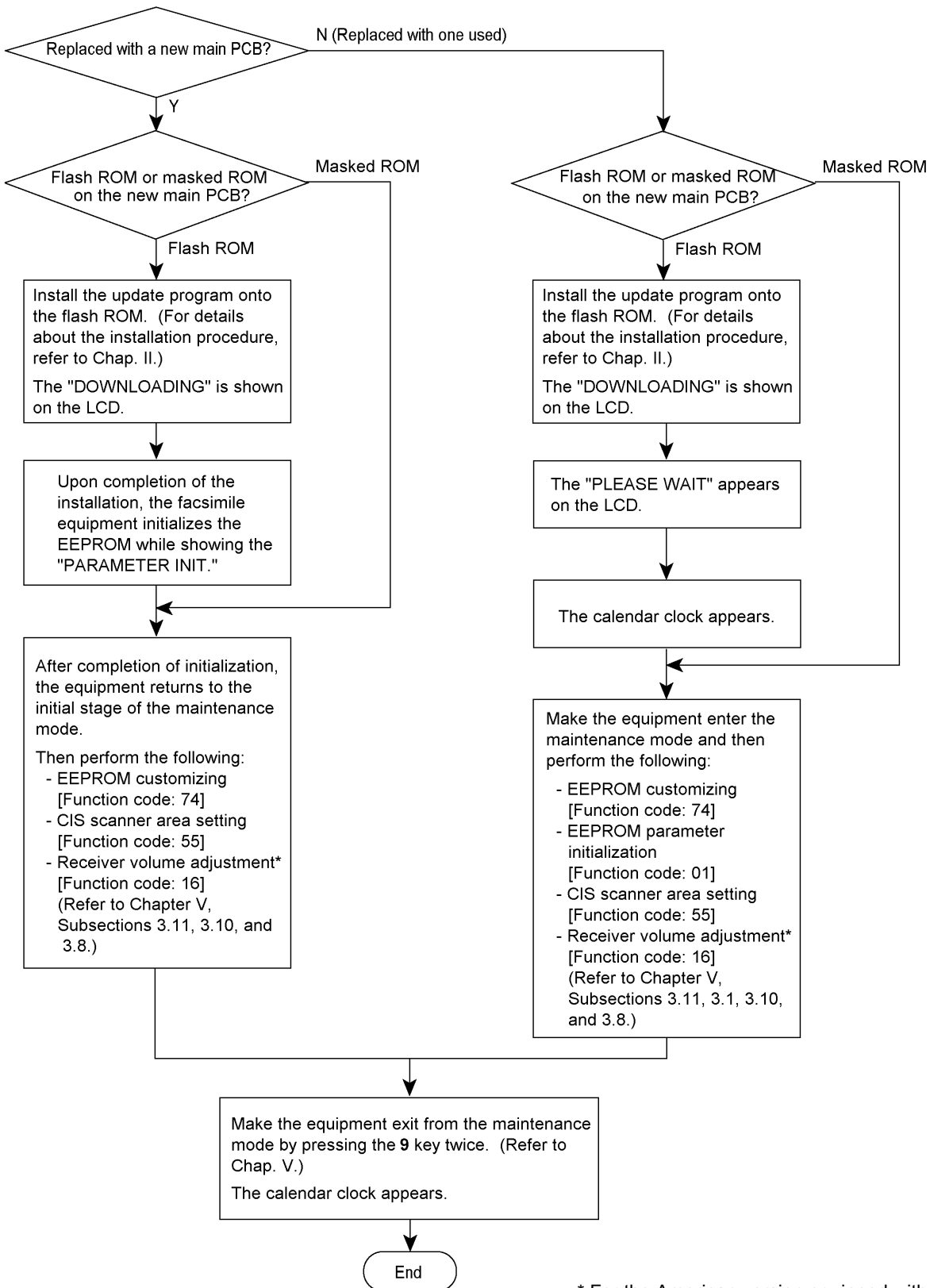

\* For the American version equipped with a handset.

### 1.22 Low-voltage Power Supply PCB and Power Inlet

- (1) Remove two screws "g" and take off the rear underbar.
- (2) Remove screw "h."
- (3) Slightly lift up the low-voltage power supply PCB and disconnect the heater harness and main-LV-engine harness. The low-voltage power supply PCB is connected to the power inlet with soldered lead wires.
- (4) Remove screw "i."
- (5) While holding up the low-voltage power supply PCB, take out the power inlet from the main chassis to the inside in the direction of the arrow shown below.
- (6) To separate the power inlet from the low-voltage power supply PCB, unsolder the two lead wires from the PCB.

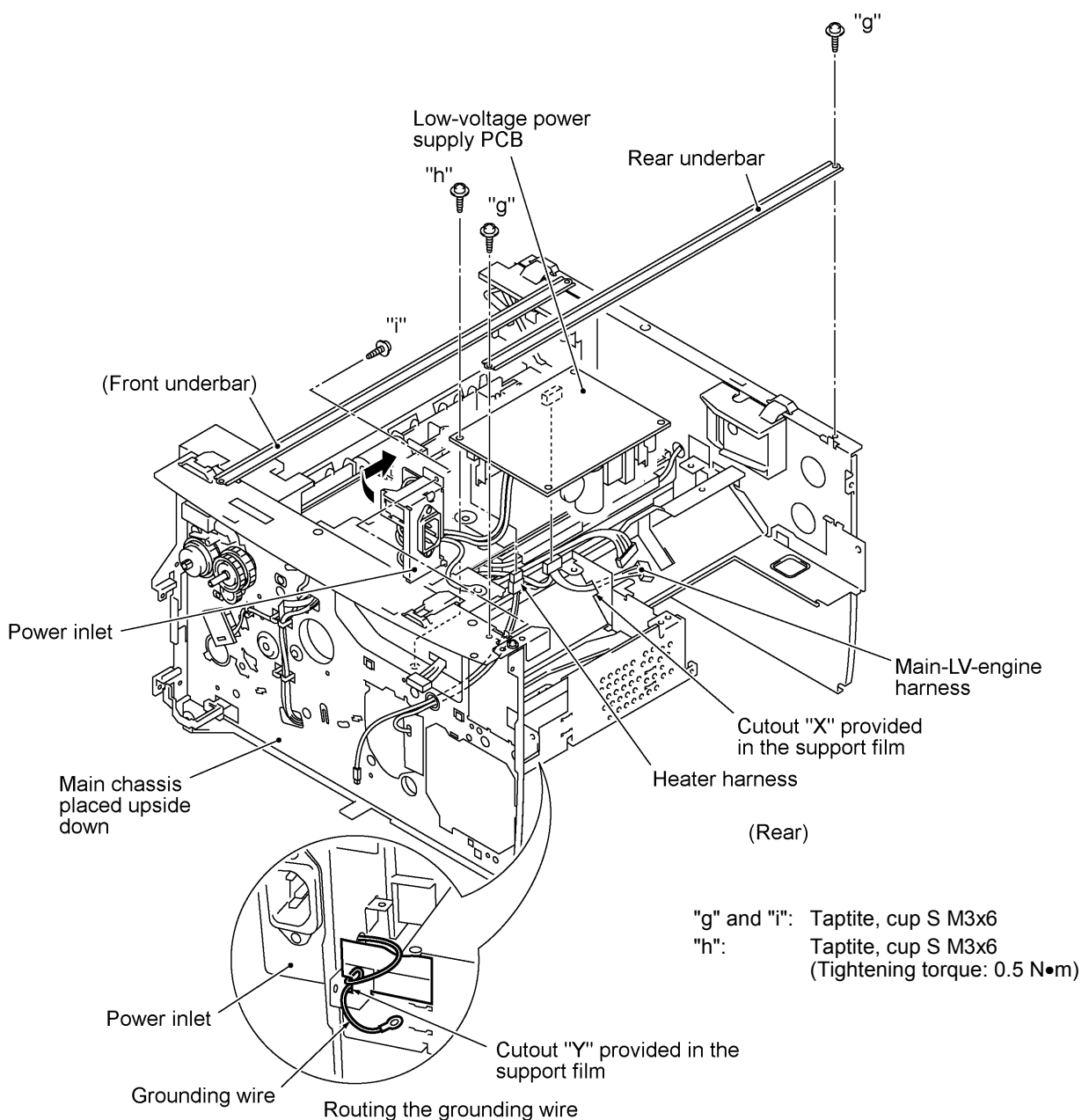

■ **Reassembling Notes**

- When connecting the power inlet to the low-voltage power supply PCB, insert the brown and blue lead wires into eyelets L and N in the PCB, respectively, and then solder those wires on the solder side of the PCB.

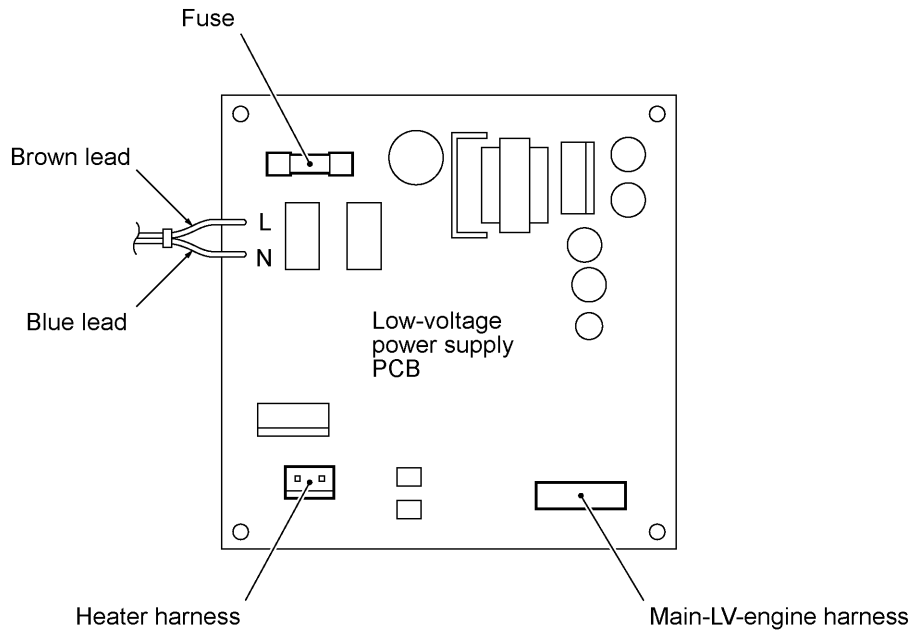

- After setting the power inlet back into place, fold the grounding wire into two and route the fold through cutout "Y" provided in the support film as shown on the previous page.
- When reinstalling the low-voltage power supply PCB, route the main-LV-engine harness through cutout "X" provided in the support film as shown on the previous page.



**1.23 Inner Insulation Film, High-voltage Power Supply PCB, Engine PCB, and 2nd Cassette Relay PCB\***

(\*Provided on models available with a 2nd paper cassette)

- (1) Remove screw "a" and take off the inner insulation film.
- (2) Remove three screws (two "b" and one "c") from the high-voltage power supply PCB and engine PCB.
- (3) Slightly lift up the high-voltage power supply PCB and disconnect it from the engine PCB.
- (4) Pull the spring up and out.
- (5) Slightly hold up the engine PCB and disconnect the following harnesses:
  - Toner sensor (light-receiver) harness (3-pin, P1)
  - Main-LV-engine harness (2-pin, P15)
  - 2nd cassette relay harness\* (8-pin, P8)
  - Heater thermistor harness (2-pin, P6), if the heat-fixing unit has not been removed
  - Fan harness (2-pin, P7), if the fan has not been removed
  - Toner sensor (LED) harness (4-pin, P10)
  - Main motor harness (6-pin, P9)
  - Polygon motor harness (5-pin, P12)
  - Solenoid harness (2-pin, P13)

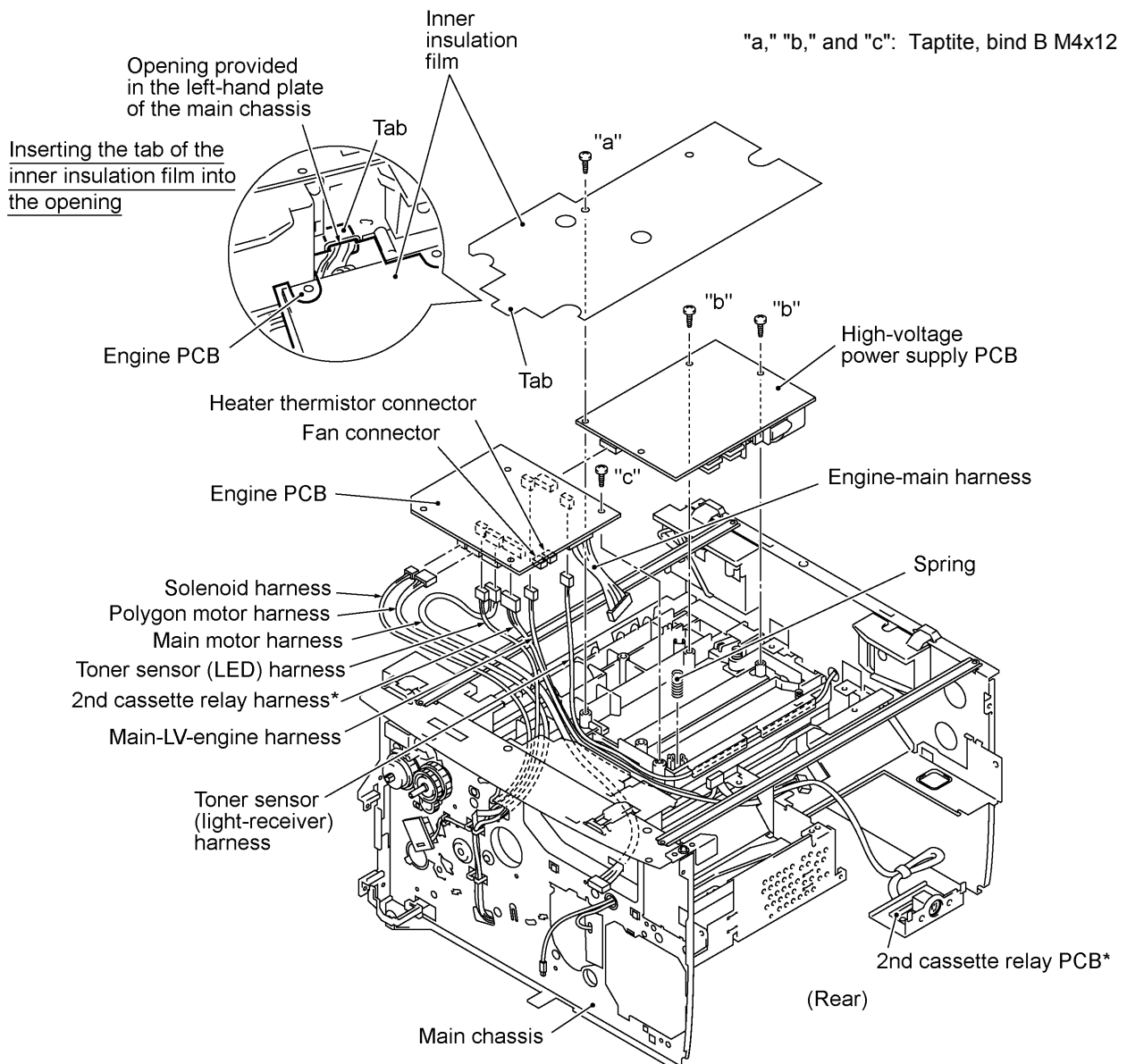

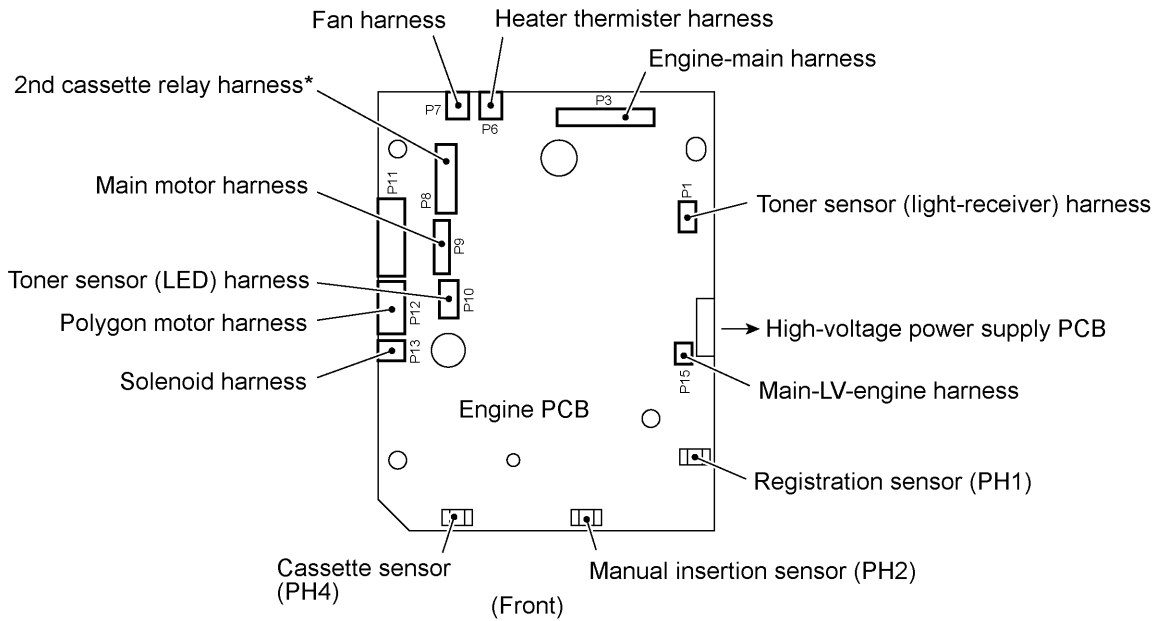

- (6) For models available with a 2nd paper cassette: Pull the 2nd cassette relay PCB bracket to take out its harness. Remove the screw and take off the 2nd cassette relay PCB from its bracket.

■ **Reassembling Notes**

- Before reinstalling the high-voltage power supply PCB, push in the spring with a flat screwdriver until it snaps into place as shown below.

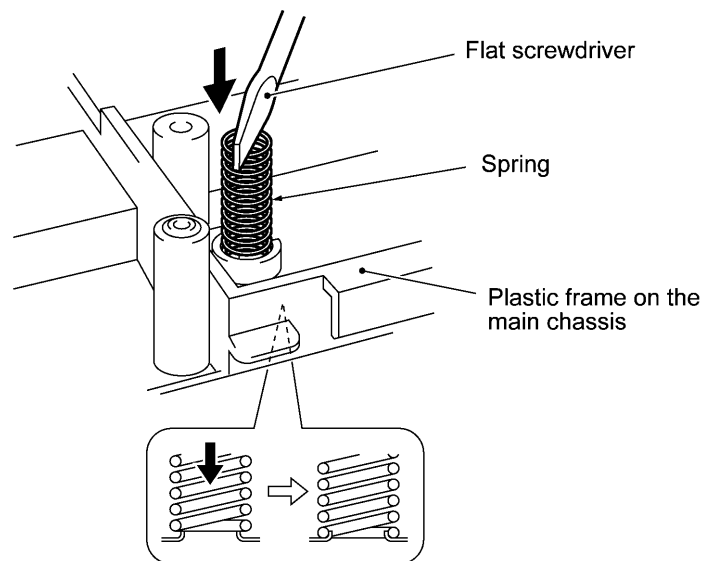

- Before reinstalling the high-voltage power supply PCB, check the high-voltage contacts for any toner particles, paper dust or dirt, and clean them out.

### 1.24 Toner Sensor (light-receiver) PCB and Toner Sensor (LED) PCB

- (1) At the right-hand plate of the main chassis, remove the screw from the toner sensor (light-receiver) PCB, release its harness from the two harness latches, and then pull it out.
- (2) At the left-hand plate of the main chassis, press the both sides of the lens support on the toner sensor (LED) PCB with your fingers to release them from the main chassis, release its harness from the two latches, and then pull it out.

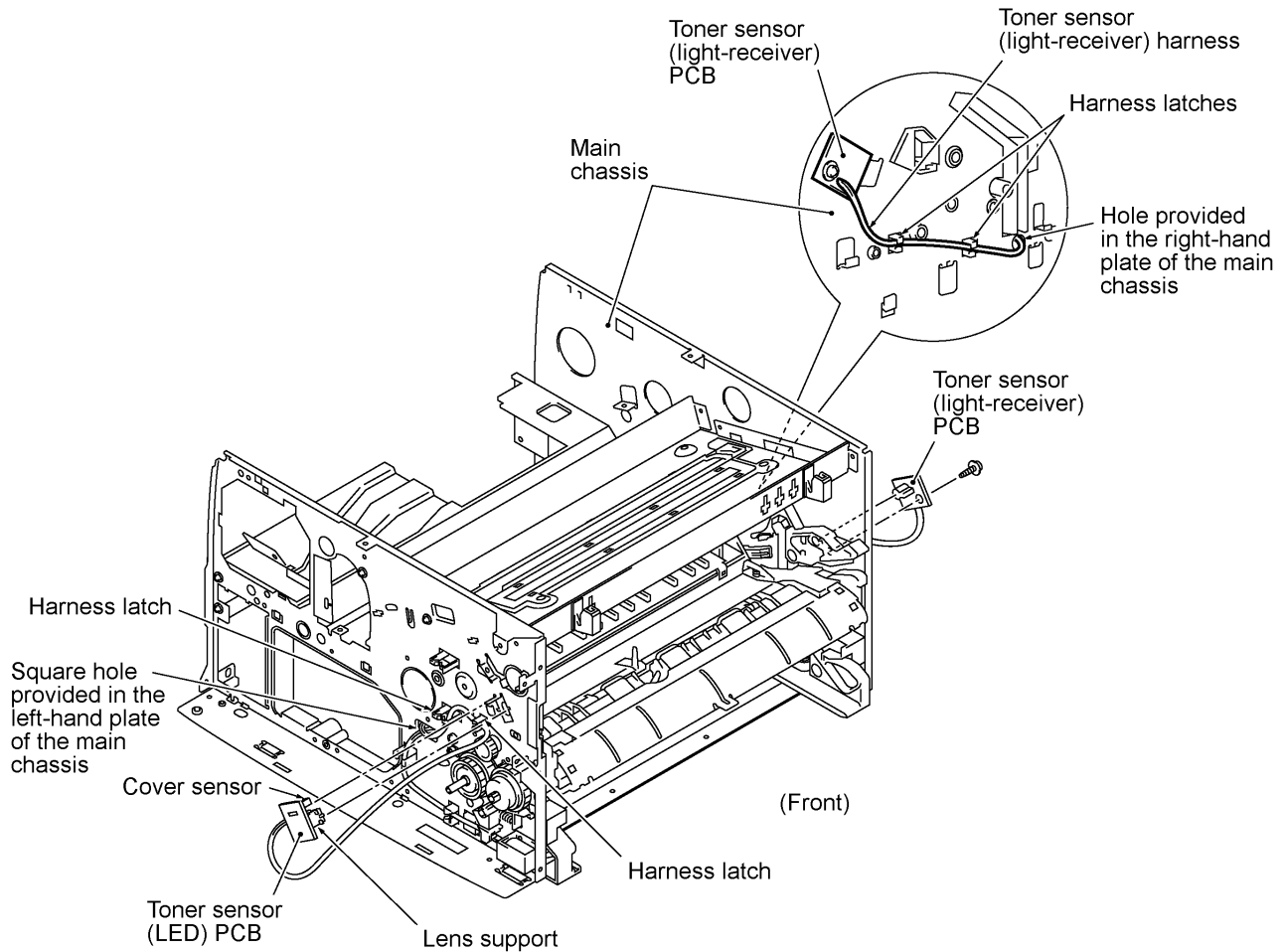

#### ■ Reassembling Notes

- Route the toner sensor (LED) harness on the left-hand side of the main chassis as shown above. Also refer to the illustration given on page IV-56.
- Route the toner sensor (light-receiver) harness on the right-hand side of the main chassis as shown above and on the top of the plastic frame as shown on page IV-56.

### 1.25 Gears and Paper Pick-up Roller

- (1) Place the main chassis upside down.
- (2) Remove the inner gear 54 (by pulling its pawl outwards), gear 45 set P/R, gear 20 P/R, and the bushing from the end of the paper pick-up roller shaft.
- (3) Remove the pawled bushing by pulling its pawl outwards, then remove the paper pick-up roller and its shaft.
- (4) Remove the gear 40/54, gear 45 set F/R, and gear 20 F/R.
- (5) If the engine PCB has been removed, take out the cassette sensor actuator. (This prevents the actuator from dropping during the following disassembly jobs.)

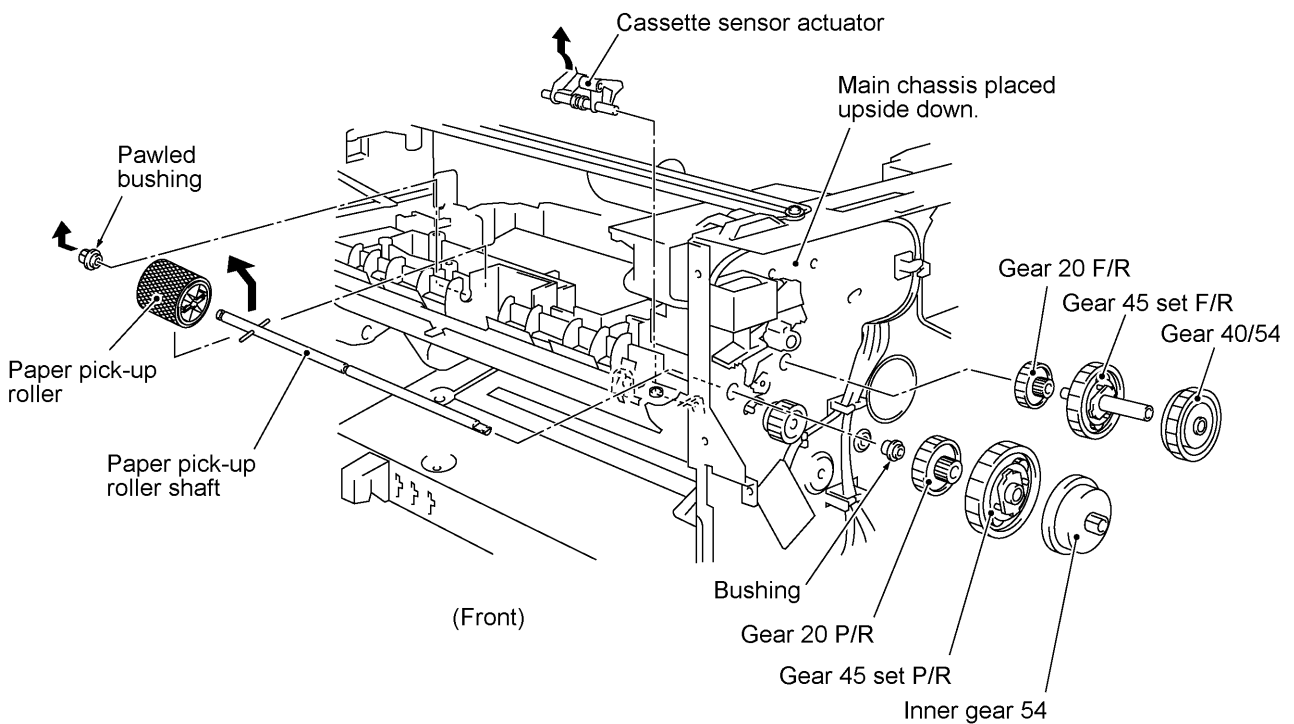

### 1.26 Paper Feed Roller ASSY

- (1) Unhook the latch (arrow ①) provided on the underside of the plastic frame by using a small flat screwdriver and pull out the gear 21 (arrow ②).
- (2) Place the main chassis rightside up.
- (3) At the right end of the paper feed roller shaft, pull up the pawl of the bushing (arrow ③) with the tip of a flat screwdriver and move the paper feed roller ASSY to the left (arrow ④). Then take out the bushing and paper feed roller ASSY.
- (4) Remove the joint (arrow ⑤).

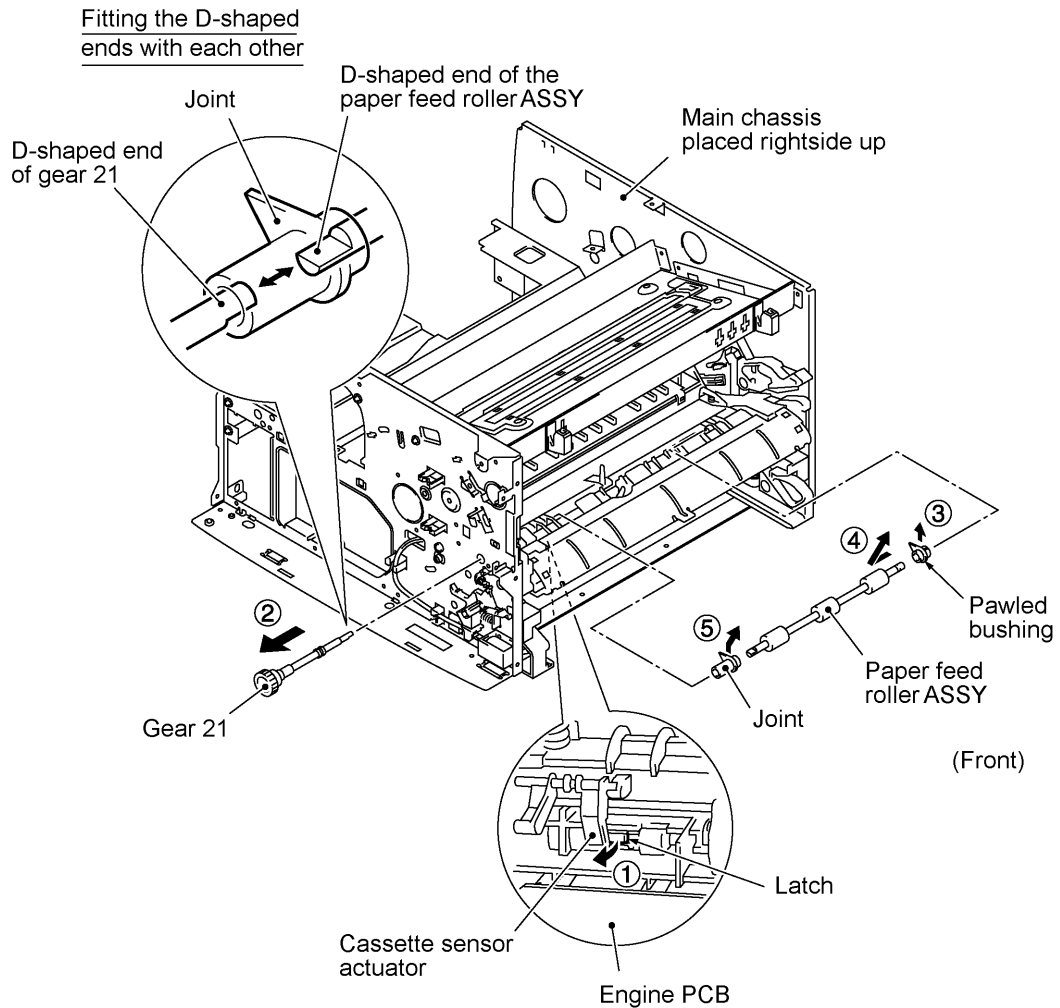

#### ■ Reassembling Notes

- When setting the gear 21 back into place, insert it and turn it so that its D-shaped end becomes fitted with the D-shaped end of the paper feed roller ASSY.

### 1.27 Clutch Levers, Cassette Guide L, and Solenoid

- (1) Turn the main chassis upside down.
- (2) Remove the two screws and take off the front underbar (which is shown on page IV-54).
- (3) Place the main chassis rightside up.
- (4) Remove the clutch lever F/R by pulling its pawl outwards.
- (5) Remove the clutch lever spring and clutch lever P/R.
- (6) Remove the plunger and solenoid release spring.
- (7) Remove two screws "a" and take off the cassette guide L.
- (8) Remove screw "b" and take off the solenoid.

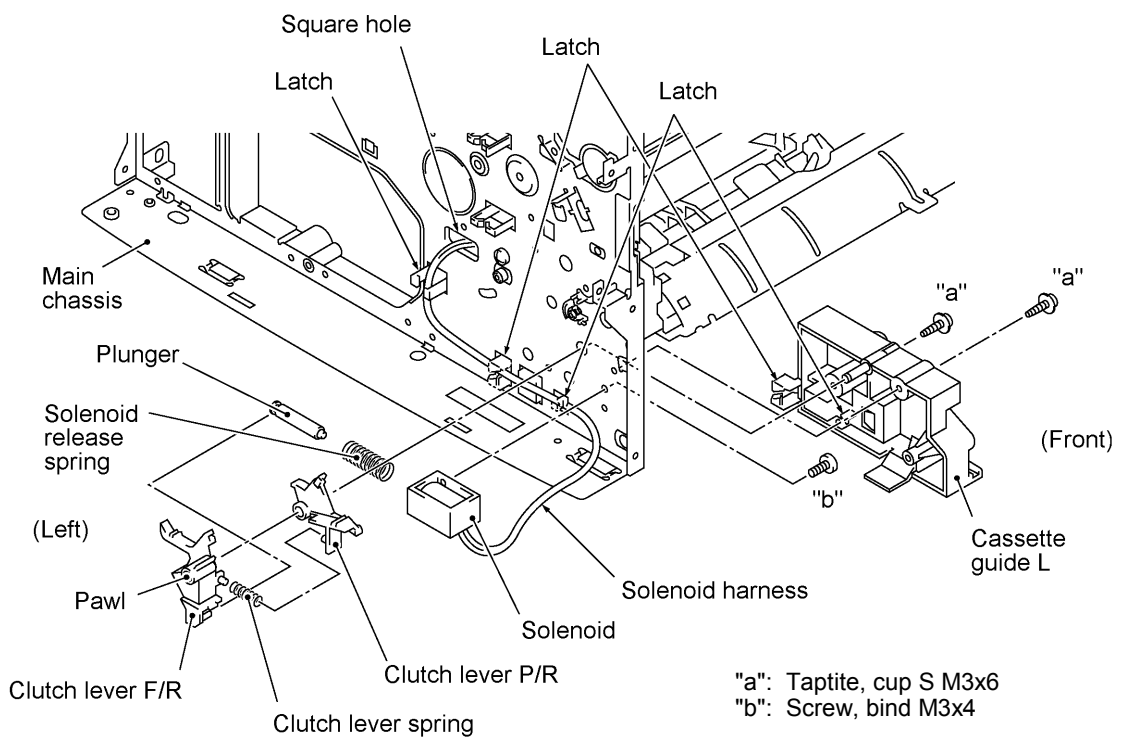

#### ■ Reassembling Notes

- Route the solenoid harness through three latches and pass it through the square hole provided in the left-hand plate of the main chassis.

### 1.28 Paper Cassette

- (1) Pull the pressure plate release lever to the front to release the pressure plate.
- (2) Fully slide the side guide (R or L) inwards (in the direction of arrow ①) and remove the screw. Then release the latches (arrow ②) and pull up the side guide (arrow ③).
- (3) Release the pressure plate from the bosses (arrow ④) and remove it (arrow ⑤).
- (4) Fully slide the paper rear guide to the front and lift it up (arrow ⑥).

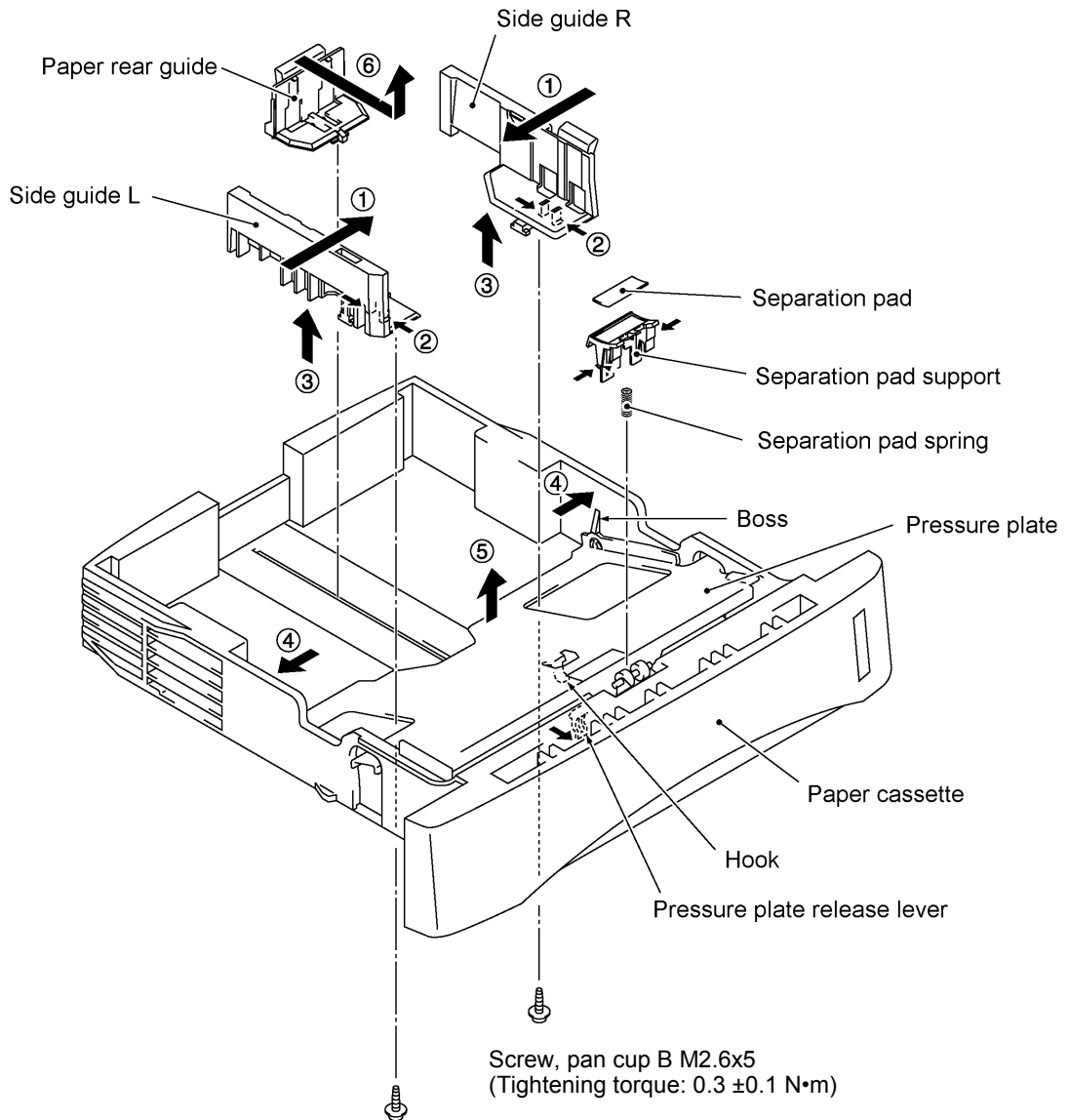

### 1.29 Cleaning of High-voltage Contacts and Grounding Contacts

If any toner particles, paper dust or dirt are on the contacts, clean them out. This will ensure that power flows correctly to enable printing.

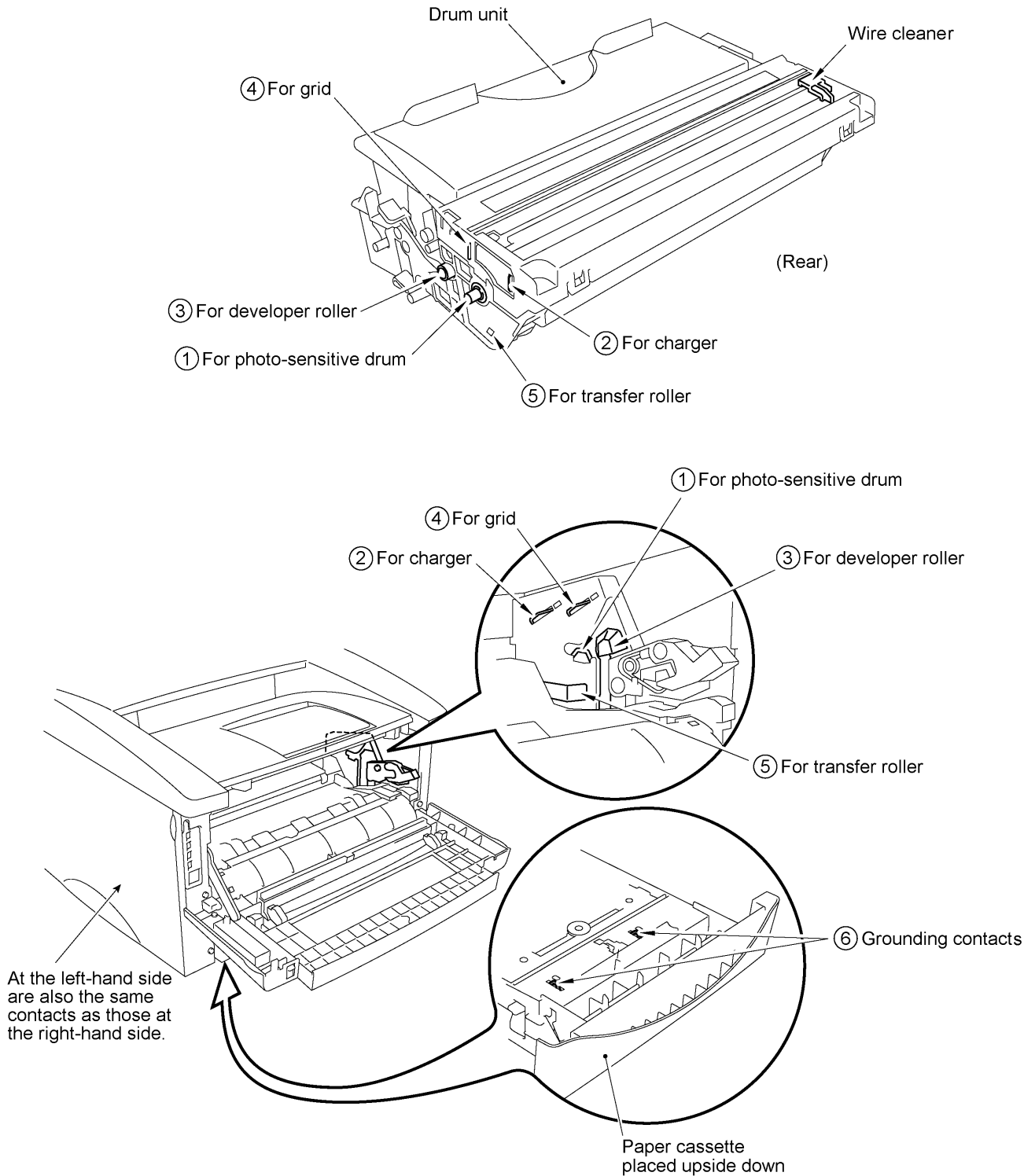



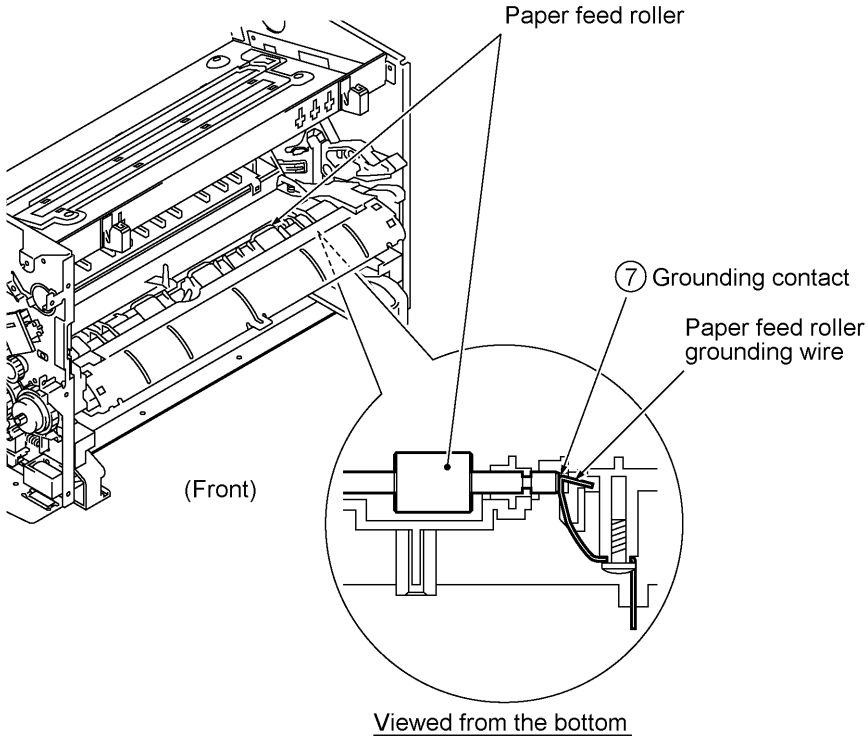

## 2. LUBRICATION

Apply the specified lubricants to the lubrication points as shown below.

Lubricant type (Manufacturer)	Lubricant amount			
	Half of a rice-sized pinch of grease (3 mm <sup>3</sup> )	Rice-sized pinch of grease (6 mm <sup>3</sup> )	Two rice-sized pinches of grease (12 mm <sup>3</sup> )	Five rice-sized pinches of grease (30 mm <sup>3</sup> )
Molykote grease EM-30L (Dow Corning)	EM0.5	EM1	EM2	EM5
Molykote grease EMD-110 (Dow Corning.)	—	EMD1	—	—
Molykote grease PG662 (Dow Corning)	—	PG1	—	—

### [ 1 ] Document feed roller ASSY and document ejection roller ASSY

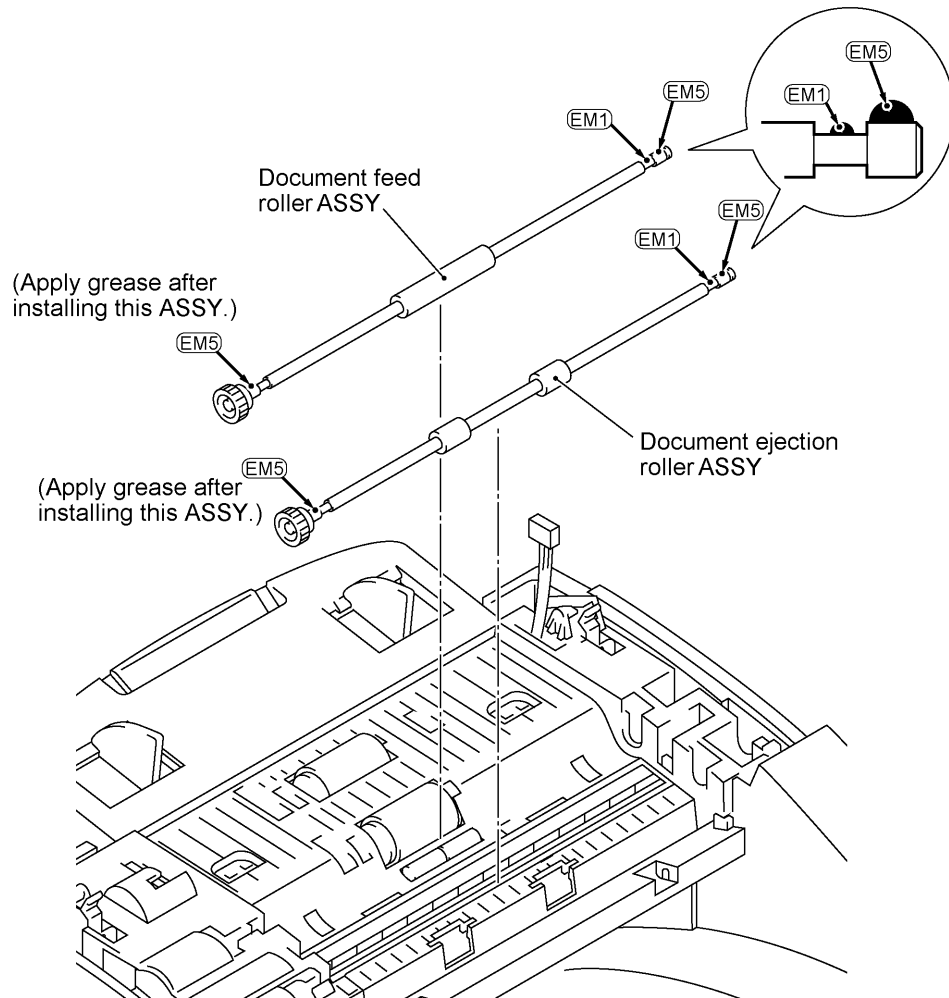

[ 2 ] Control panel locks

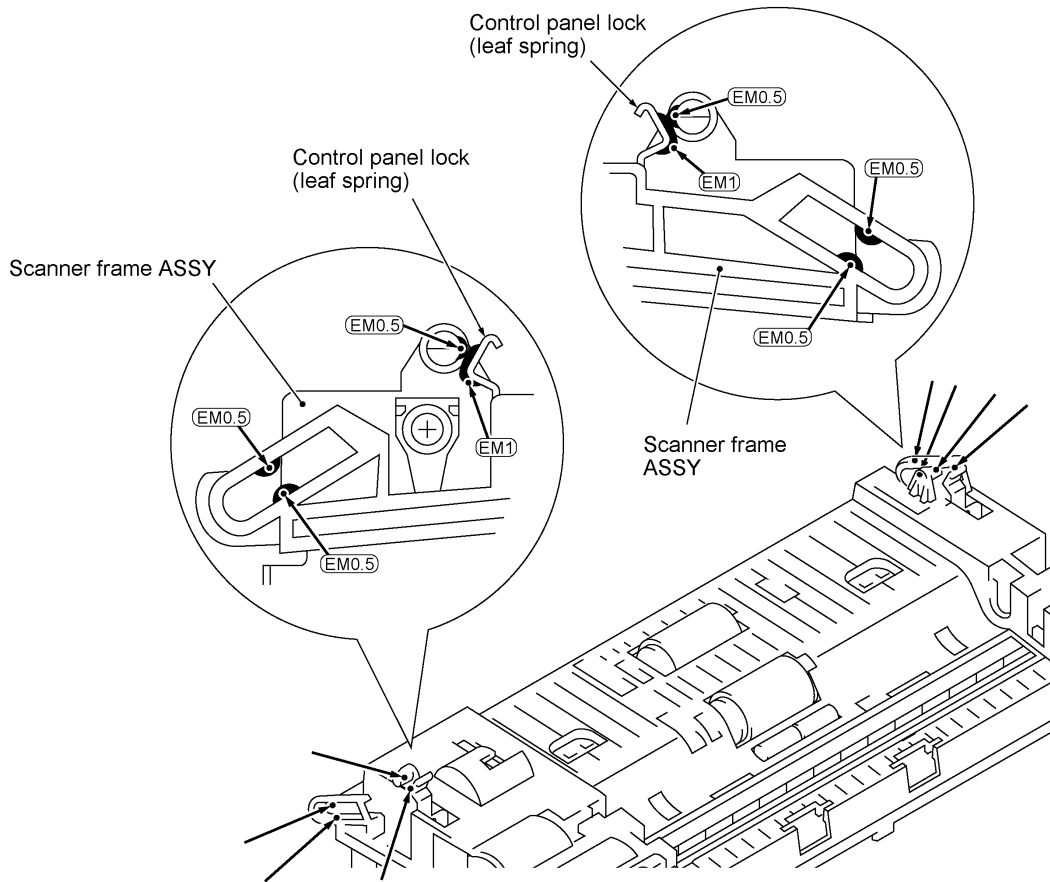

[ 3 ] Scanner frame ASSY, document take-in roller and its shaft, and separation roller and its shaft

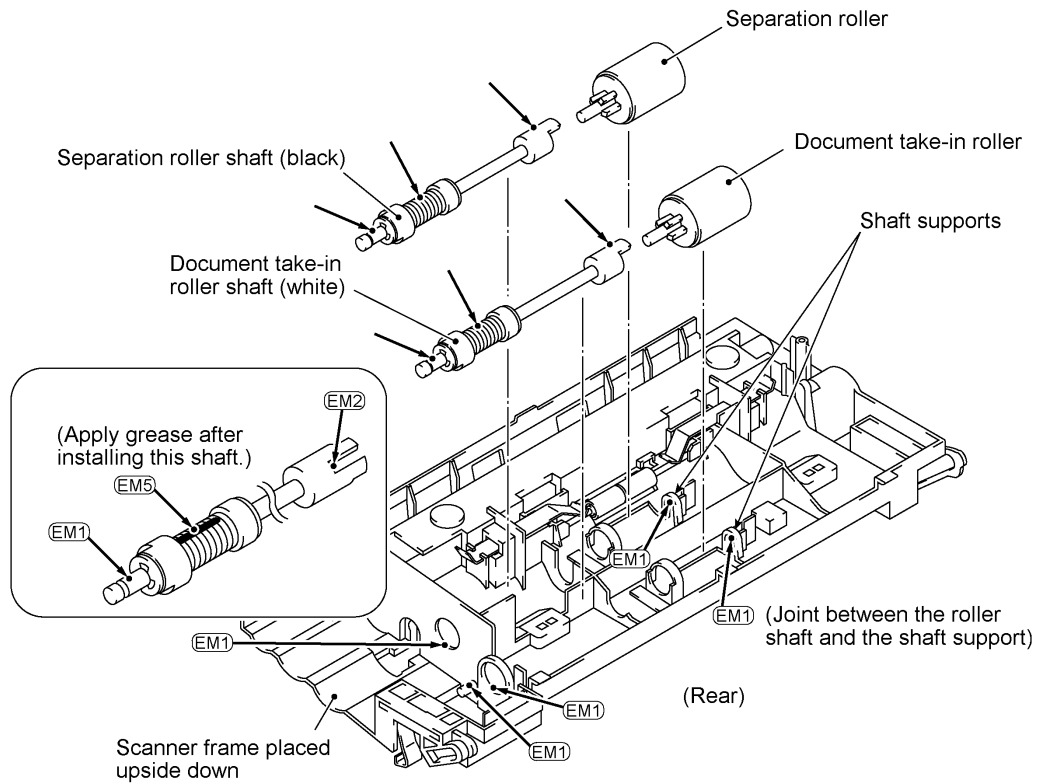

[ 4 ] Top cover

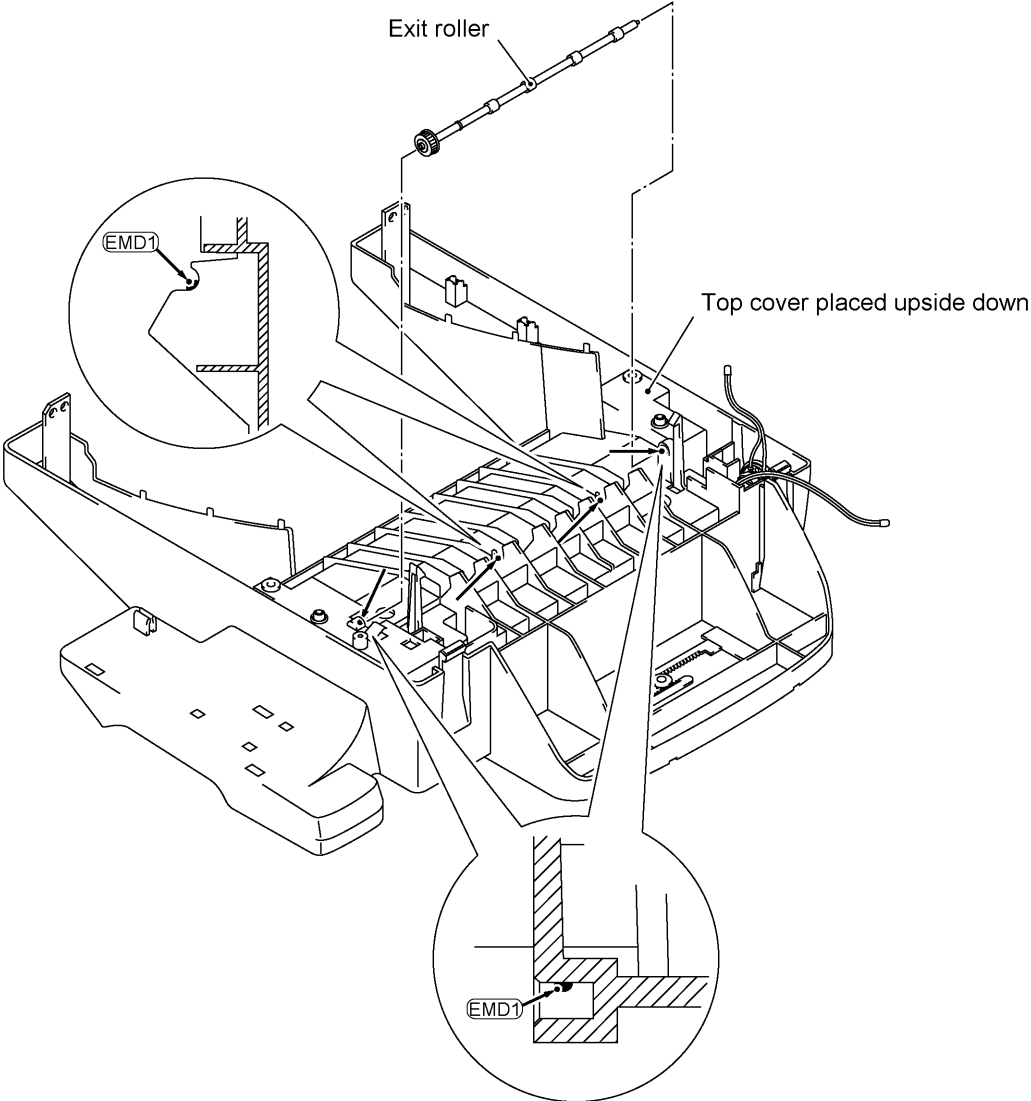

[ 5 ] Drive gear ASSY

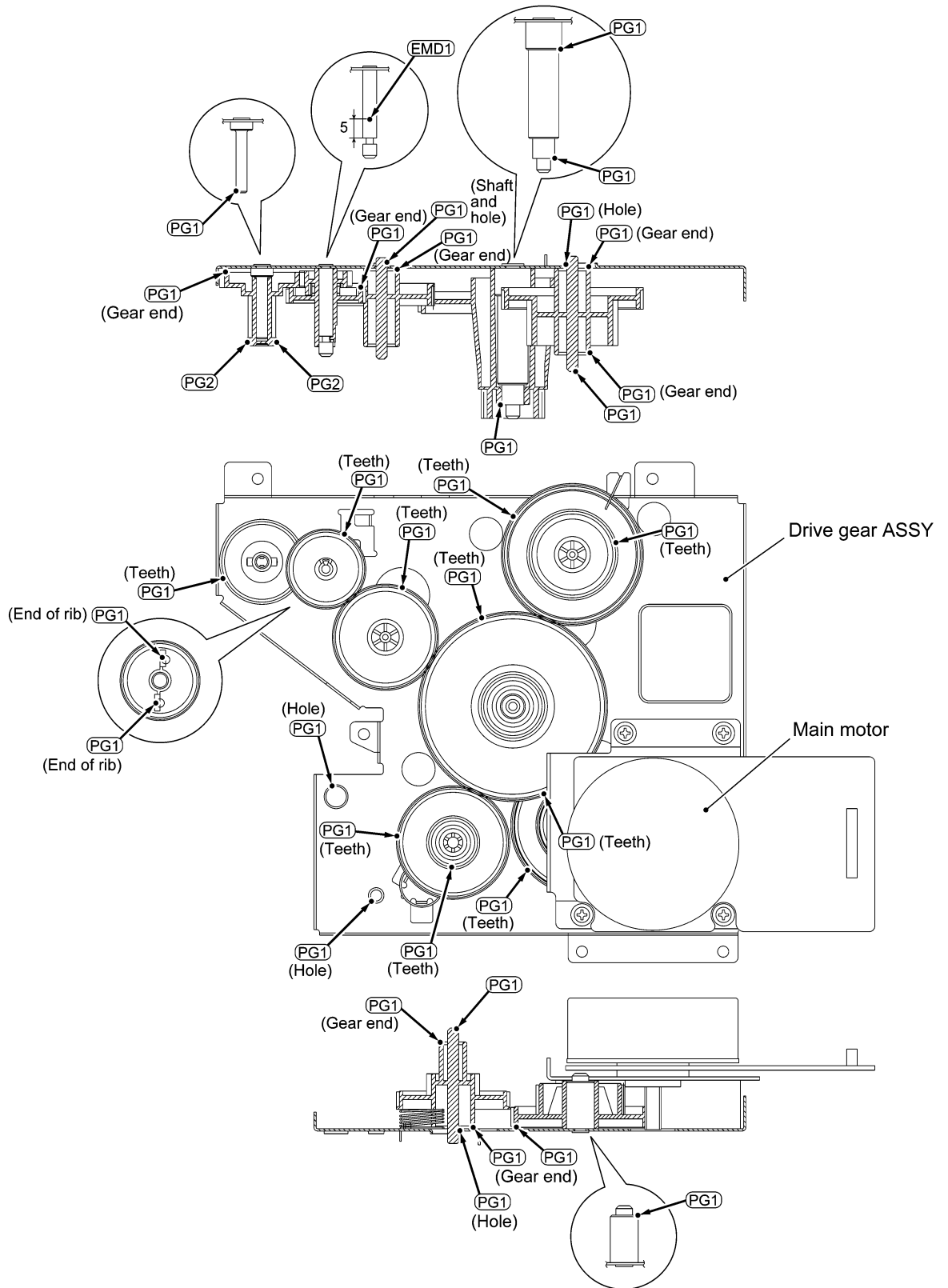

[ 6 ] Paper cassette

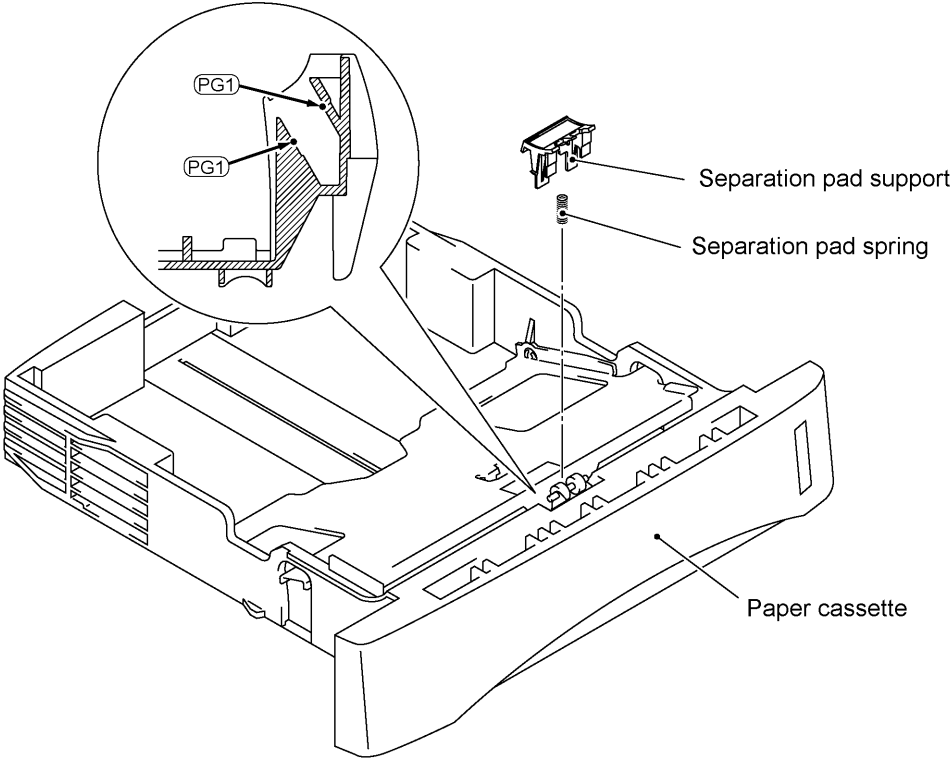

# **CHAPTER V.**

## **MAINTENANCE MODE**

## CHAPTER V. MAINTENANCE MODE

### CONTENTS

<b>1.</b>	<b>ENTRY INTO THE MAINTENANCE MODE .....</b>	<b>V-1</b>
<b>2.</b>	<b>LIST OF MAINTENANCE-MODE FUNCTIONS .....</b>	<b>V-2</b>
<b>3.</b>	<b>DETAILED DESCRIPTION OF MAINTENANCE-MODE FUNCTIONS .....</b>	<b>V-4</b>
3.1	EEPROM Parameter Initialization .....	V-4
3.2	Printout of Scanning Compensation Data .....	V-5
3.3	ADF Performance Test .....	V-7
3.4	Test Pattern 1 .....	V-8
3.5	Firmware Switch Setting and Printout .....	V-9
3.6	Operational Check of LCD .....	V-12
3.7	Operational Check of Control Panel PCB .....	V-12
3.8	Receiver Volume Adjustment (applicable to the American version only).....	V-14
3.9	Sensor Operational Check .....	V-15
3.10	Fine Adjustment of Scanning Start/End Position.....	V-16
3.11	CIS Scanner Area Setting .....	V-17
3.12	EEPROM Customizing .....	V-17
3.13	Display of the Equipment's Log Information.....	V-18
3.14	Equipment Error Code Indication .....	V-19
3.15	Output of Transmission Log to the Telephone Line .....	V-19
3.16	Cancellation of the Memory Security Mode (applicable to the European version only) .....	V-20



# 1. ENTRY INTO THE MAINTENANCE MODE

To make the equipment enter the maintenance mode, press the **Menu**, **\***, **2**, **8**, **6**, and **4** keys in this order.

|← Within 2 seconds →|

The equipment beeps for approx. one second and displays " ■■ MAINTENANCE ■■■ " on the LCD, indicating that it is placed in the initial stage of the maintenance mode, a mode in which the equipment is ready to accept entry from the keys.

To select one of the maintenance-mode functions listed in Section 2, enter the corresponding 2-digit function code with the numerical keys on the control panel. (The details of each maintenance-mode function are described in Section 3.)

**NOTES:**

- Pressing the **9** key twice in the initial stage of the maintenance mode makes the equipment exit from the maintenance mode, restoring it to the standby state.

If you want to initialize the EEPROM (Function code: 01), however, you need to turn the power off after the initialization procedure without pressing the **9** key twice. Pressing the **9** key twice will not fully initialize the EEPROM.

- Pressing the **Stop** key after entering only one digit restores the equipment to the initial stage of the maintenance mode.
- If an invalid function code is entered, the equipment resumes the initial stage of the maintenance mode.

## 2. LIST OF MAINTENANCE-MODE FUNCTIONS

### Maintenance-mode Functions

Function Code	Function	Reference Subsection (Page)
01	EEPROM Parameter Initialization	3.1 (V-4)
02	_____	_____
03	_____	_____
04	_____	_____
05	Printout of Scanning Compensation Data	3.2 (V-5)
06	_____	_____
07	_____	_____
08	ADF* Performance Test	3.3 (V-7)
09	Test Pattern 1	3.4 (V-8)
10	Firmware Switch Setting	3.5 (V-9)
11	Printout of Firmware Switch Data	3.5 (V-11)
12	Operational Check of LCD	3.6 (V-12)
13	Operational Check of Control Panel PCB (Check of Keys and Buttons)	3.7 (V-12)
14	_____	_____
15	_____	_____
16	Receiver Volume Adjustment (applicable to the American version only)	3.8 (V-14)
32	Sensor Operational Check	3.9 (V-15)
54	Fine Adjustment of Scanning Start/End Position	3.10 (V-16)
55	CIS Scanner Area Setting	3.11 (V-17)
74	EEPROM Customizing	3.12 (V-17)
80	Display of the Equipment's Log Information	3.13 (V-18)
82	Equipment Error Code Indication	3.14 (V-19)
87	Output of Transmission Log to the Telephone Line	3.15 (V-19)
91	EEPROM Parameter Initialization (except the telephone number storage area)	3.1 (V-4)
99	Exit from the Maintenance Mode	---- (V-1)

\* ADF: Automatic document feeder

----- IMPORTANT -----

Basically, the maintenance-mode functions listed on the previous page should be accessed by service personnel only. However, you may allow end users to access some of these under the guidance of service personnel (e.g., by telephone).

The user-accessible functions (codes 10, 11, 12, 54, 80, 82, 87 and 91) are shaded in the table given on the previous page. Function code 10 accesses the firmware switches, each of which has eight selectors. You should not allow end users to access all of those selectors, but you may allow them to access user-accessible selectors which are shaded in the firmware switch tables in Appendix 2.

The service personnel should instruct end users to follow the procedure given below.

- (1) Press the **Menu** and **Mode** keys in this order.

The LCD clears the current display.

**NOTE:** The **Mode** key is inoperable during standby for redialing and timer.

- (2) Press the **0** key.
- (3) Enter the desired function code (10, 11, 12, 54, 80, 82, 87, or 91) with the numerical keys.  
For function code 10, access the desired firmware switch according to the operating procedure described in Appendix 2.
- (4) To make the equipment return to the standby state, press the **Stop** key.

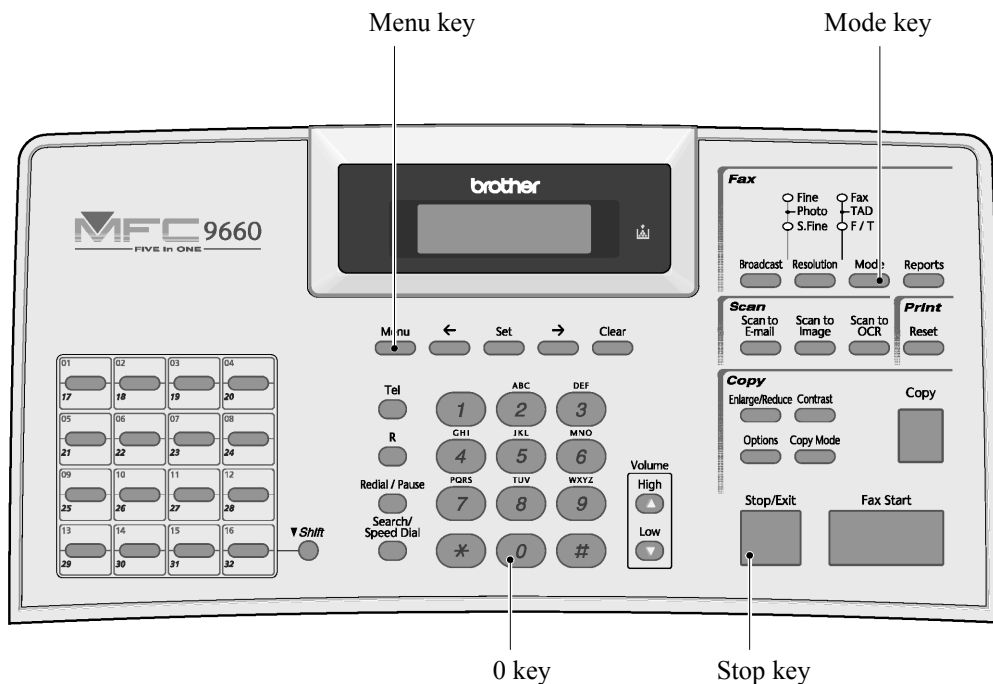

### 3. DETAILED DESCRIPTION OF MAINTENANCE-MODE FUNCTIONS

#### 3.1 EEPROM Parameter Initialization

##### ■ Function

The equipment initializes the parameters, user switches, and firmware switches registered in the EEPROM, to the initial values. Entering the function code 01 initializes all of the EEPROM areas, but entering 91 does not initialize some areas, as listed below.

Function code	01	91
Data item		
Maintenance-mode functions	All of these will be initialized	These will be initialized
User switches		
Firmware switches		
Remote activation code		These will <u>not</u> be initialized
Activity report		
Station ID data		
Outside line number		
Telephone function registration		
One-touch dialing		
Speed dialing		
Group dialing		
Received FAX messages		
EEPROM customizing code (4-digit)	These will <u>not</u> be initialized. (Note that the first digit of the 4-digit customizing code will be initialized to "0." If the code is <u>1001</u> , for example, it will be initialized to <u>0001</u> .)	

**NOTE:** If you replace the main PCB with one used for other facsimile equipment, carry out this procedure and then customize the EEPROM (maintenance-mode function code 74 in Subsection 3.12).

##### ■ Operating Procedure

- (1) Press the **0** and **1** keys (or the **9** and **1** keys according to your need) in this order in the initial stage of the maintenance mode.  
The "PARAMETER INIT" will appear on the LCD.
- (2) Upon completion of parameter initialization, the equipment returns to the initial stage of the maintenance mode.
- (3) Be sure to turn the machine power off. If you press the **9** key twice to exit from the maintenance mode without turning the power off, then the machine will not fully initialize the EEPROM.

### 3.2 Printout of Scanning Compensation Data

#### ■ Function

The equipment prints out the white and black level data for scanning compensation.

#### ■ Operating Procedure

Do not start this function merely after powering on the equipment but start it after carrying out a sequence of scanning operation. Unless the equipment has carried out any scanning operation, this function cannot print out correct scanning compensation data. This is because at the start of scanning operation, the equipment initializes white and black level data and takes in the scanning compensation reference data.

- (1) Press the **0** and **5** keys in this order in the initial stage of the maintenance mode.

The "WHITE LEVEL 1" will appear on the LCD.

- (2) The equipment prints out the scanning compensation data list containing the following:

- a) LED light intensity value (1 byte)
- b) A/D-high value (1 byte)
- c) A/D-low value (1 byte)
- d) Compensation data for background color (1 byte)
- e) 2-value quantization black level data (2464 bytes)
- f) 2-value quantization white level data (2464 bytes)

- (3) Upon completion of recording of the compensation data list, the equipment returns to the initial stage of the maintenance mode.

**NOTE:** If any data is abnormal, its code will be printed in inline style, as shown on the next page.

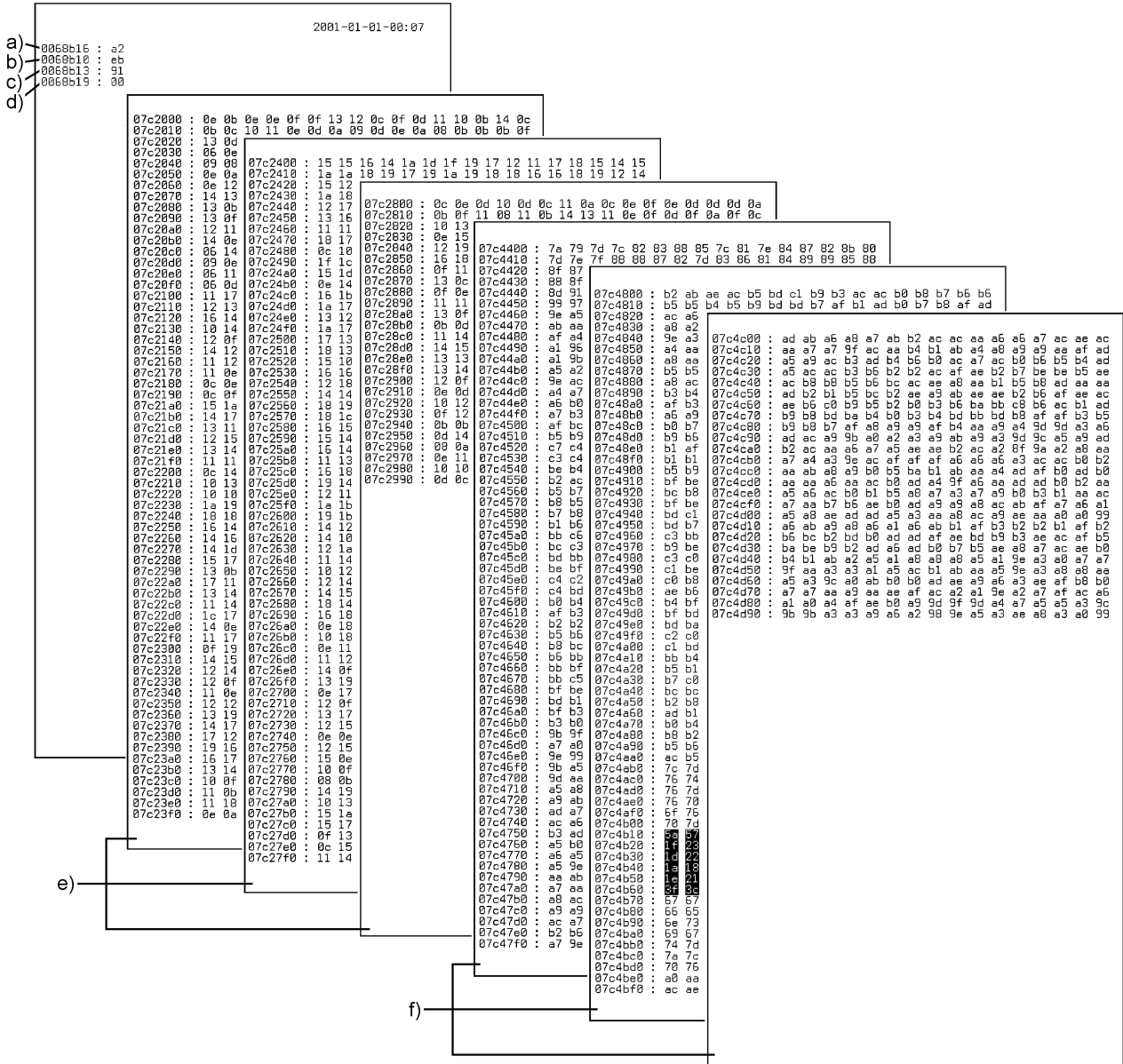

Scanning Compensation Data List

### 3.3 ADF Performance Test

#### ■ Function

The equipment counts the documents fed by the automatic document feeder (ADF) and displays the count on the LCD for checking the ADF performance.

#### ■ Operating Procedure

- (1) Set documents. (Allowable up to the ADF capacity.)

The "DOC. READY" will appear on the LCD.

- (2) Press the **0** and **8** keys in this order.

While counting the documents, the equipment feeds them in and out, displaying the current count on the LCD as shown below.

ADF CHECK P.01

↑  
— Current count (1st page in this example)

- (3) After showing the final count, the equipment beeps for one second. To return the equipment to the initial stage of the maintenance mode, press the **Stop** key.

### 3.4 Test Pattern 1

#### ■ Function

This function, much like the copying function, prints out test pattern 1 to allow the service personnel to check for record data missing or print quality.

#### ■ Operating Procedure

Press the **0** and **9** keys in this order in the initial stage of the maintenance mode.

The figure below shows test pattern 1.

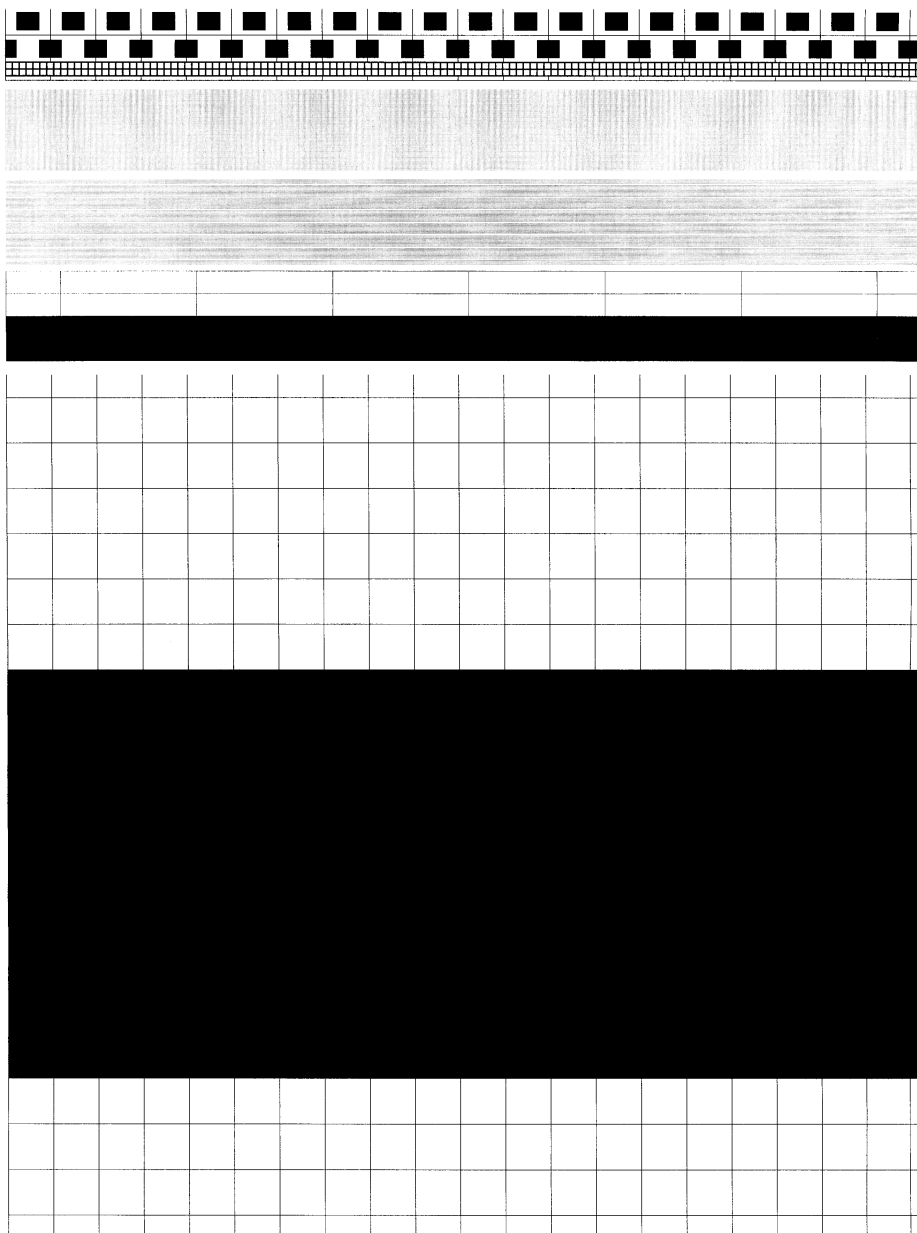

Test Pattern 1



### 3.5 Firmware Switch Setting and Printout

#### [ A ] Firmware switch setting

##### ■ Function

The facsimile equipment incorporates the following firmware switch functions which may be activated with the procedures using the control panel keys and buttons.

The firmware switches have been set at the factory in conformity to the communications standards and codes of each country. Do not disturb them unless necessary. Some firmware switches may not be applicable in some versions. The firmware switch data list indicates "Not used." for those inapplicable switches.

#### Firmware Switches (WSW01 through WSW50)

WSW No.	Function	For details, refer to Appendix 2, Page
WSW01	Dial pulse setting	2
WSW02	Tone signal setting	3
WSW03	PABX mode setting	4
WSW04	TRANSFER facility setting	6
WSW05	1st dial tone and busy tone detection	7
WSW06	<b>Pause</b> key setting and 2nd dial tone detection	9
WSW07	Dial tone setting 1	11
WSW08	Dial tone setting 2	12
WSW09	Protocol definition 1	13
WSW10	Protocol definition 2	14
WSW11	Busy tone setting	15
WSW12	Signal detection condition setting	16
WSW13	Modem setting	17
WSW14	AUTO ANS facility setting	18
WSW15	REDIAL facility setting	19
WSW16	Function setting 1	20
WSW17	Function setting 2	21
WSW18	Function setting 3	22
WSW19	Transmission speed setting in V. 17 mode	23
WSW20	Overseas communications mode setting	24
WSW21	TAD setting 1	25
WSW22	ECM setting	25
WSW23	Communications setting	26
WSW24	TAD setting 2	27
WSW25	TAD setting 3	28
WSW26	Function setting 4	29
WSW27	Function setting 5	30
WSW28	Function setting 6	31
WSW29	Function setting 7	32
WSW30	Function setting 8	32
WSW31	Function setting 9	33
WSW32	Function setting 10	34
WSW33	Function setting 11	34

Firmware Switches (WSW01 through WSW50) *Continued*

WSW No.	Function	Reference Page
WSW34	Function setting 12	35
WSW35	Function setting 13	35
WSW36	Function setting 14	36
WSW37	Function setting 15	37
WSW38	Function setting 16, in V. 34 mode	38
WSW39	Transmission speed setting in V. 34 mode	39
WSW40	Function setting 17, in V. 34 mode	40
WSW41	CCD fluorescent lamp and modem attenuator, in V. 34 mode	42
WSW42	Function setting 18	43
WSW43	Function setting 19	44
WSW44	Speeding up scanning-1	44
WSW45	Speeding up scanning-2	45
WSW46	Monitor of power ON/OFF state and parallel port kept at high	46
WSW47	Delay of FAX line disconnection	47
WSW48 to 50	Not used.	47

### ■ Operating Procedure

- (1) Press the **1** and **0** keys in this order in the initial stage of the maintenance mode.  
The equipment displays the "WSW00" on the LCD and becomes ready to accept a firmware switch number.
- (2) Enter the desired number from the firmware switch numbers (01 through 50).  
The following appears on the LCD:
 

Selector 1	Selector 8
↓	↓
WSWXX = 0 0 0 0 0 0 0 0	
- (3) Use the **◀** and **▶** keys to move the cursor to the selector position to be modified.
- (4) Enter the desired number using the **0** and **1** keys.
- (5) Press the **Set** key. This operation saves the newly entered selector values onto the EEPROM and readies the equipment for accepting a firmware switch number.
- (6) Repeat steps (2) through (5) until the modification for the desired firmware switches is completed.
- (7) Press the **Set** or **Stop** key to return the equipment to the initial stage of the maintenance mode.

**NOTES:**

- To cancel this operation and return the equipment to the initial stage of the maintenance mode during the above procedure, press the **Stop** key.
- If there is a pause of more than one minute after a single-digit number is entered for double-digit firmware switch numbers, the equipment will automatically return to the initial stage of the maintenance mode.

### ■ Details of Firmware Switches

The details of the firmware switches are described in Appendix 2 in which the user-accessible selectors of the firmware switches are shaded.

[ B ] Printout of firmware switch data

■ Function

The equipment prints out the setting items and contents specified by the firmware switches.

■ Operating Procedure

- (1) Press the **1** key twice in the initial stage of the maintenance mode.  
The "PRINTING" will appear on the LCD.
- (2) The equipment prints out the configuration list as shown in the figure below.
- (3) Upon completion of printing, the equipment returns to the initial stage of the maintenance mode.

CONFIGURATION LIST

MODEL : 8X5-513  
TIME : 01/01/2001 00:11  
REV. : U0104041249VER.0  
PCI : 5.00  
SUM : 9BAB  
SER.# : IXXXXXXXXXX

```
WSW01 = 00000010
WSW02 = 11111010
WSW03 = 10000000
WSW04 = 00010111
WSW05 = 00000110
WSW06 = 00101100
WSW07 = 01001100
WSW08 = 01100100
WSW09 = 00000000
WSW10 = 00010100
WSW11 = 01011000
WSW12 = 10011011
WSW13 = 00011010
WSW14 = 01100110
WSW15 = 00001110
WSW16 = 01100010
WSW17 = 00100011
WSW18 = 10001010
WSW19 = 11100000
WSW20 = 10011111
WSW21 = 00101000
WSW22 = 00000000
WSW23 = 00001110
WSW24 = 01000010
WSW25 = 00011010
WSW26 = 00110010
WSW27 = 00100001
WSW28 = 00000000
WSW29 = 01101001
WSW30 = 10000000
WSW31 = 11100101
WSW32 = 01010000
WSW33 = 10000010
WSW34 = 00010000
WSW35 = 01000000
WSW36 = 00001000
WSW37 = 10000101
WSW38 = 00010100
WSW39 = 11110000
WSW40 = 00000000
WSW41 = 00000111
WSW42 = 11110100
WSW43 = 00000001
WSW44 = 00000010
WSW45 = 00000000
```

Configuration List

### 3.6 Operational Check of LCD

#### ■ Function

This function allows you to check whether the LCD on the control panel works normally.

#### ■ Operating Procedure

- (1) Press the **1** and **2** keys in this order in the initial stage of the maintenance mode.

The LCD shows

- (2) Press the **Fax Start** key. Each time you press the **Fax Start** key, the LCD cycles through the displays shown at right.

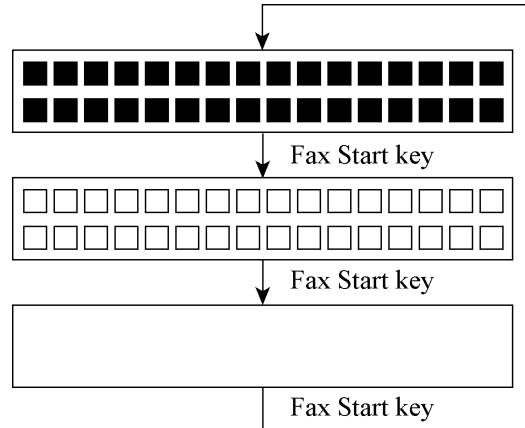

- (3) Press the **Stop** key in any process of the above display cycle. The equipment beeps for one second and returns to the initial stage of the maintenance mode.

### 3.7 Operational Check of Control Panel PCB

#### ■ Function

This function allows you to check the control panel PCB for normal operation.

#### ■ Operating Procedure

- (1) Press the **1** and **3** keys in this order in the initial stage of the maintenance mode.

The "00 " will appear on the LCD.

- (2) Press the keys and buttons in the order designated in the illustration shown below.

The LCD shows the corresponding number in decimal notation each time a key or button is pressed. Check that the displayed number is correct by referring to the illustration below.

If a key or button is pressed out of order, the equipment beeps and displays the "INVALID OPERATE" on the LCD. To return to the status ready to accept key & button entry for operational check, press the **Stop** key.

- (3) After the last number key or button is pressed, the equipment beeps and returns to the initial stage of the maintenance mode.

To terminate this operation, press the **Stop** key. The equipment returns to the initial stage of the maintenance mode.

MFC8500



MFC9660

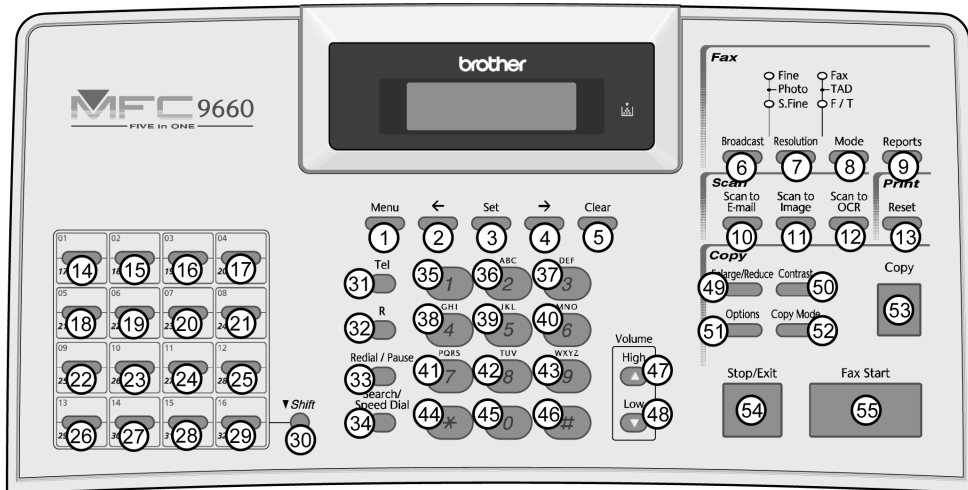

FAX4100/FAX5750e/FAX4750e/FAX8360P

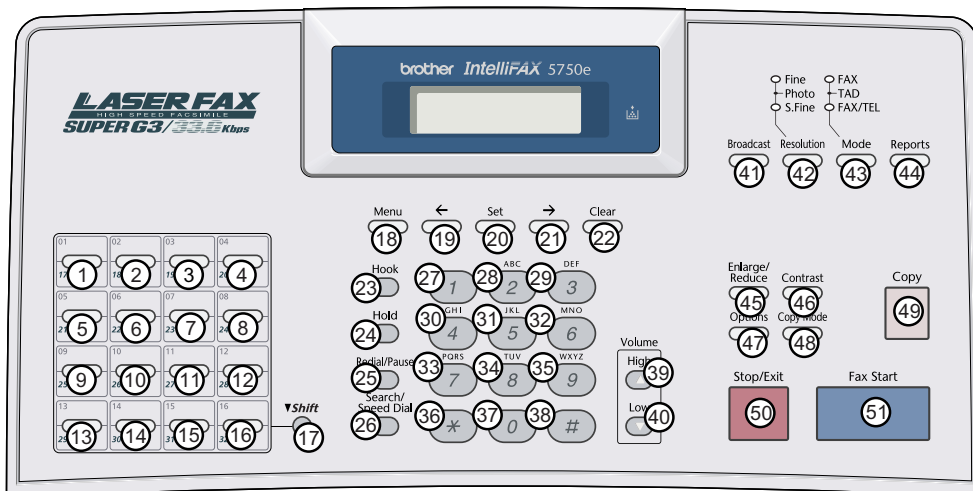

Key & Button Entry Order

### 3.8 Receiver Volume Adjustment (applicable to the American version only)

#### ■ Function

The HIGH level of the handset receiver's volume will be influenced by the characteristics of the FET on the main PCB, so it requires fine adjustment according to the procedure given below.

#### ■ Operating Procedure

- (1) Connect the telephone line cord to the modular jack of the facsimile equipment and the telephone wall socket.
- (2) Pick up the handset and listen to the dial tone. If the receiver volume is not appropriate, proceed to the following steps:
- (3) Press the **1** and **6** keys in this order in the initial stage of the maintenance mode.

The LCD shows the current receiver volume (default: HIGH).

- (4) If the current receiver volume is not HIGH, use the **Volume** keys to choose HIGH.
- (5) Press the **Fax Start** key.

The equipment enters the receiver volume adjustment mode and shows the PWM duty ratio at the right end of the LCD.

- (6) Adjust the receiver volume by using the **1**, **3**, **4**, or **6** key.

**1** key: Decrease 10H

**3** key: Increase 10 H

**4** key: Decrease 1H

**6** key: Increase 1H

- (7) To escape from the receiver volume adjustment mode, press the **Set** key.

The LCD shows the "PWM SETTING." One second later, the LCD returns to the screen shown in step (3).

- (8) To return the equipment to the initial stage of the maintenance mode, press the **Stop** key.

### 3.9 Sensor Operational Check

#### ■ Function

This function allows you to check whether the 12 sensors (11 sensors on European models)--document front sensor, document rear sensor, cover sensor, registration sensor, toner sensor, paper ejection sensor, hook switch\*, 2nd registration sensor\*\*, manual insertion sensor, cassette sensor, 2nd cassette sensor\*\*, and jam sensor--operate correctly.

(\*European models have no hook switch.)

(\*\*These sensors are provided for models supporting a 2nd paper cassette.)

#### ■ Operating Procedure

- (1) Press the **3** and **2** keys in this order in the initial stage of the maintenance mode. The equipment beeps 1100 Hz and 400 Hz tones cyclically through the following volumes for testing the speaker.

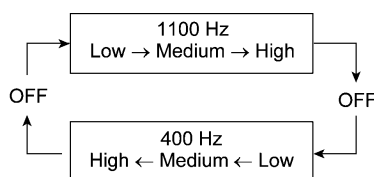

**NOTE:** To stop beeping, press the **Menu** key.

If the sensing status are as listed below, the LCD will show the following two character strings which can be switched by pressing the **Fax Start** key:

##### American models

"DFDRCVVRSTNPOHK " and "MNCS P2"

"DFDRCVVRSTNPOHKR2" and "MNCSC2P2" on models having a 2nd paper cassette

##### European models

"DFDRCVVRSTNPO " and "MNCS P2"

"DFDRCVVRSTNPO R2" and "MNCSC2P2" on models having a 2nd paper cassette

Given below is the relationship between the LCD indication, sensor names and sensor status.

LCD	Sensors	Sensing status
DF	Document front sensor	No document detected.
DR	Document rear sensor	No document detected.
CV	Cover sensor	Top cover closed.
RS	Registration sensor	No paper detected.
TN	Toner sensor	No toner detected.
PO	Paper ejection sensor	No paper jam.
HK	Hook switch*	On-hook state.
R2	2nd registration sensor**	No paper detected.
MN	Manual insertion sensor	No paper detected.
CS	Cassette sensor	No paper cassette loaded.
C2	2nd cassette sensor**	No paper cassette loaded.
P2	Jam sensor	No paper jammed.

- (2) Change the detecting conditions (e.g., insert paper through the document sensors or the registration sensor(s), open the front cover, remove the toner cartridge, jam paper at the paper outlet or inside the heat-fixing unit, lift up the handset\*, and then check that the indication on the LCD changes according to the sensor states.
- (3) To stop this operation and return the equipment to the initial stage of the maintenance mode, press the **Stop** key.

**NOTE:** If you have opened and closed the top cover during the above procedure, you need to open and close the front cover again upon completion of the procedure.

### 3.10 Fine Adjustment of Scanning Start/End Position

#### ■ Function

This function allows you to adjust the scanning start/end position.

#### ■ Operating Procedure

- (1) Press the **5** and **4** keys in this order in the initial stage of the maintenance mode.

The "SCAN START ADJ." appears on the LCD. After two seconds, the current scanning position correction value appears.

You may adjust the correction value to 11 levels from +5 to -5 (mm).

- (2) To increase the correction value, press the left arrow key; to decrease it, press the right arrow key.

If you press the **Stop** key, the equipment returns to the initial stage of the maintenance mode without making change of the correction value.

- (3) Press the **Set** key.

The "ACCEPTED" appears on the LCD. After one second, the equipment returns to the initial stage of the maintenance mode.

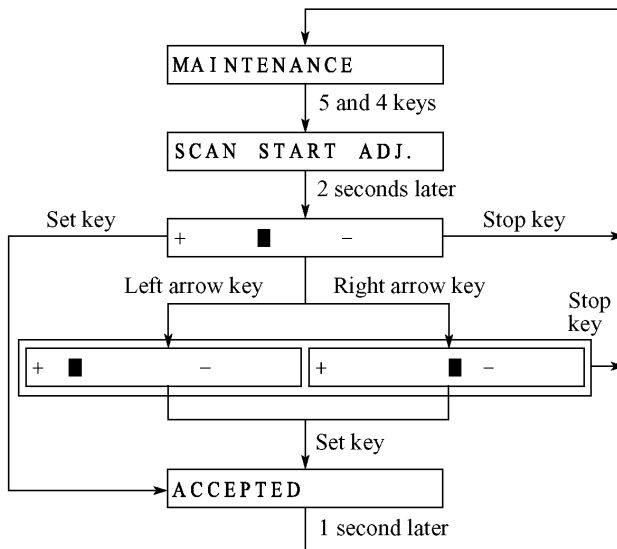

**NOTE:** The relationship between the scanning start/end positions and their correction values is shown below.

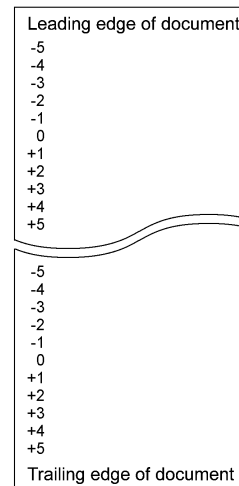



### 3.11 CIS Scanner Area Setting

#### ■ Function

The equipment sets the CIS scanner area and stores it into the EEPROM.

#### ■ Operating Procedure

- (1) Press the **5** key twice in the initial stage of the maintenance mode.

The "SCANNER AREA SET" will appear on the LCD.

The equipment checks and sets the area to be scanned.

If no error is noted, the equipment returns to the initial stage of the maintenance mode.

If any error is noted, the "SCANNER ERROR" will appear on the LCD. To return the equipment to the initial stage of the maintenance mode, press the **Stop** key.

### 3.12 EEPROM Customizing

#### ■ Function

This function allows you to customize the EEPROM according to language, function settings, and firmware switch settings. The customizing codes list is given in Appendix 1.

**NOTE:** If you replace the main PCB, be sure to carry out this procedure.

#### ■ Operating Procedure

- (1) Press the **7** and **4** keys in this order in the initial stage of the maintenance mode.

The current customizing code (e.g., 9001 in the case of MFC8500 USA version) appears.

- (2) Enter the desired customizing code (e.g., 0002 in the case of MFC8500 Canadian version).

The newly entered code appears.

**NOTE:** *If a wrong 4-digit code is entered, the equipment will malfunction.*

- (3) Press the **Fax Start** key.

The equipment saves the setting and returns to the initial stage of the maintenance mode.

If you press the **Stop** key or no keys are pressed for one minute in the above procedure, the equipment stops the procedure and returns to the initial stage of the maintenance mode.

### 3.13 Display of the Equipment's Log Information

#### ■ Function

The equipment may display its log information on the LCD.

#### ■ Operating Procedure

- (1) Press the **8** and **0** keys in this order in the initial stage of the maintenance mode.  
The USB serial number appears on the LCD.
- (2) Press the **Fax Start** key.  
Each time the **Fax Start** key is pressed, one of the following log information items appears on the LCD in the order given below.
  - 1) ID code assigned to the facsimile machine
  - 2) Jam count, indicating how many times a paper jam has been occurred
  - 3) Page count, indicating how many pages the current drum has been printed
  - 4) Total page count, indicating how many pages the equipment has been printed since produced
  - 5) Drum count, indicating how many times the drum has been rotated
  - 6) Drum change count, indicating how many times drum replacement has been made
  - 7) Toner change count, indicating how many times toner replacement has been made
  - 8) Copy page count (not appear on the MFC8500), indicating how many copies have been made
  - 9) PC print page count (not appear on the MFC8500), indicating how many pages the equipment has been printed as an output device of the connected PC
  - 10) FAX page count (not appear on the MFC8500), indicating how many received FAX pages have been printed
  - 11) Error code of the most recent machine error\*<sup>1</sup>
  - 12) Error code of the most recent communications error\*<sup>2</sup>
  - 13) ADF jam count, indicating how many times a document jam has been occurred
  - 14) ADF page count, indicating how many documents have been fed
- (3) To stop this operation and return to the equipment to the initial stage of the maintenance mode, press the **Stop** key.

\*<sup>1</sup> When a machine error is displayed, pressing the **Menu** key toggles between the latest error and 2nd latest error.

\*<sup>2</sup> When a communications error is displayed, pressing the **Menu** key cycles through the latest error, 2nd latest error, and 3rd latest error.

### 3.14 Equipment Error Code Indication

#### ■ Function

This function displays an error code of the last error on the LCD.

#### ■ Operating Procedure

- (1) Press the **8** and **2** keys in this order in the initial stage of the maintenance mode.  
The LCD shows the "MACHINE ERROR X X."
- (2) To stop this operation and return the equipment to the initial stage of the maintenance mode, press the **Stop** key.

### 3.15 Output of Transmission Log to the Telephone Line

#### ■ Function

This function outputs the transmission log (that the equipment has stored about the latest transmission) to the telephone line. It allows the service personnel to receive the transmission log of the user's equipment at a remote location and use it for analyzing problems arising in the user's equipment.

#### ■ Operating Procedure

- (1) If the user's equipment has a transmission-related problem, call the user's equipment at a remote location from your equipment.
- (2) If the line is connected, have the user perform the following:
  - 1) Press the **Menu**, **Mode**, and **0** keys in this order.
  - 2) Press the **8** and **7** keys.

The above operation makes the user's equipment send CNG to your equipment for sending the transmission log.

- (3) If you hear the CNG sent from the user's equipment, press the **Fax Start** key of your equipment.

Your equipment will start to receive the transmission log from the user's equipment.

### 3.16 Cancellation of the Memory Security Mode (applicable to the European version only)

#### ■ Function

This procedure can cancel the memory security mode. Use this procedure if the user forgets his/her password entered when setting the memory security mode so as not to exit from the memory security mode.

**NOTE:** Carrying out this procedure will lose passwords previously entered but retain FAX messages received in the memory security mode.

#### ■ Operating Procedure

- (1) When the SECURE MODE is displayed on the LCD, hold down the **Menu** key and press the # key. Within two seconds, start to press the **2, 7, 9, 0,** and **0** keys.

The memory security mode will be canceled and the equipment returns to the calendar clock screen.

# **CHAPTER VI.**

## **ERROR INDICATION AND TROUBLESHOOTING**

# CHAPTER VI. ERROR INDICATION AND TROUBLESHOOTING

## CONTENTS

<b>1. ERROR INDICATION.....</b>	<b>VI-1</b>
1.1 Equipment Errors .....	VI-1
[ 1 ] Error messages on the LCD .....	VI-1
[ 2 ] Error codes shown in the "MACHINE ERROR <u>X</u> <u>X</u> " message.....	VI-5
1.2 Communications Errors .....	VI-7
<b>2. TROUBLESHOOTING.....</b>	<b>VI-17</b>
2.1 Introduction .....	VI-17
2.2 Precautions .....	VI-17
2.3 Checking prior to Troubleshooting.....	VI-17
2.4 Troubleshooting Procedures.....	VI-19
[ 1 ] Control panel related .....	VI-19
[ 2 ] Telephone related.....	VI-19
[ 3 ] Communications related.....	VI-20
[ 4 ] Paper/document feeding related .....	VI-20
[ 5 ] Print-image related .....	VI-21
Location of High-voltage Contacts and Grounding Contacts .....	VI-28

# 1. ERROR INDICATION

To help the user or the service personnel promptly locate the cause of a problem (if any), the facsimile equipment incorporates the self-diagnostic functions which display error messages for equipment errors and communications errors.

For the communications errors, the equipment also prints out the transmission verification report and the communications list.

## 1.1 Equipment Errors

If an equipment error occurs, the facsimile equipment emits an audible alarm (continuous beeping) for approximately 4 seconds and shows the error message on the LCD. For the error messages, see [ 1 ] below.

To display detailed error information, use the maintenance-mode function code 82 described in Chapter V, Section 3.13 (that is, make the equipment enter the maintenance mode and then press the **8** and **2** keys). Following the MACHINE ERROR, one of the error codes listed in [ 2 ] will appear on the LCD.

### [ 1 ] Error messages on the LCD

Messages on the LCD	Probable Cause
(In the 1st row) CHECK PAPER, CHECK PAPER#1, or CHECK PAPER#2  (In the 2nd row) RELOAD PAPER	Even after paper pick-up operation, the manual insertion sensor does not detect paper.  (For those models available with a 2nd paper cassette, the "CHECK PAPER#1" or "CHECK PAPER#2" will appear if the manual insertion sensor or 2nd registration sensor does not detect paper, respectively. If both sensors detect no paper, the "CHECK PAPER" will appear.)
(In the 1st row) CHECK CASSETTE, CHECK CASSETTE#1, or CHECK CASSETTE#2  (In the 2nd row) Reinstall cassette properly.	The cassette sensor detects that no paper cassette is loaded.  (For those models available with a 2nd paper cassette, the "CHECK CASSETTE#1" or "CHECK CASSETTE#2" will appear if the cassette sensor or the 2nd cassette sensor does not detect paper cassette, respectively. If both sensors detect no cassette, the "CHECK CASSETTE" will appear.)
(In the 1st row) COVER OPEN  (In the 2nd row) PLS CLOSE COVER	The cover sensor detects that the front cover is not closed.

Messages on the LCD	Probable Cause
<p>(In the 1st row) CHECK DOCUMENT CHECK ORIGINAL</p> <p>(In the 2nd row) Remove document, then press STOP KEY.</p>	<p>■ Document jam</p> <p>(1) The document length exceeds the limitation (400 or 90 cm) registered by firmware switch WSW16. (Refer to Appendix 2.) (Both the document front and rear sensors stay ON after the document has been fed by the registered length.)</p> <p>(2) The document rear sensor detects no trailing edge of a document after the document has been fed by 400 cm. (The document rear sensor stays ON even after the document has been fed when the document front and rear sensors were OFF and ON, respectively.)</p> <p>■ Document loading error</p> <p>(1) The document rear sensor detects no leading edge of a document within 10 seconds from the start of document loading operation. (The document rear sensor stays OFF even after the document has been fed when the document front sensor was ON.)</p> <p>(2) The loaded document is too short. (Since the document is shorter than the distance between the document front and rear sensors, the document front sensor is turned OFF before the document rear sensor is turned ON.)</p>
CLEAN UP SCANNER	<p>In the scanning compensation data list printed by the maintenance-mode function code 05, less than fifty percent of the white level data is faulty. (This message may appear only in the maintenance mode.)</p>
SCANNER ERROR	<p>In the scanning compensation data list printed by the maintenance-mode function code 05, fifty percent or more of the white level data is faulty. (This message may appear only in the maintenance mode.)</p>
TONER LOW	The toner sensor has detected that there is not enough toner.
<p>(In the 1st row) TONER EMPTY</p> <p>(In the 2nd row) Open cover, then replace new toner cartridge.</p>	The toner sensor has detected that there is no toner in the cartridge or that no toner cartridge is loaded. If this message appears, recording is no longer possible.
<p>(In the 1st row) COOLING DOWN</p> <p>(In the 2nd row) WAIT FOR A WHILE</p>	The controller, which monitors the internal resistance of the in-casing temperature sensor (thermistor) and heater thermistor, has detected that the temperature inside the equipment or the heater temperature exceeded the specified level. If either temperature exceeds the preset level, recording is no longer possible.



Messages on the LCD	Probable Cause
<p>(In the 1st row) WARMING UP</p> <p>(In the 2nd row) WAIT FOR A WHILE</p>	<p>The controller, which monitors the internal resistance of the in-casing temperature sensor (thermistor) and heater thermistor, has detected that the temperature inside the equipment or the heater temperature has not reached the specified level. If either temperature does not reach the preset level, recording is not possible.</p>
<p>(In the 1st row) MACHINE ERROR XX</p> <p>(In the 2nd row) Unplug machine, then call Brother.</p>	<p>"XX" indicates an error code. Refer to [ 2 ] on pages VI-5 and VI-6.</p>
<p>CHANGE DRUM SOON</p>	<p>The service life of the drum unit will expire soon. This message appears for one minute.</p> <p>(You can turn this message indication on or off by the maintenance-mode function code 10, WSW31, selector 8. Refer to Appendix 2.)</p>
<p>PLS OPEN COVER</p>	<p>To display the relating detailed error code, use maintenance-mode function code 82. (Refer to Chapter V, Section 3.14.)</p> <p>If this message appears, open and close the front cover. The message may disappear if opening/closing the front cover removes the error. If the error persists, the "MACHINE ERROR XX" will appear.</p>
<p>(In the 1st row) PAPER JAM</p> <p>(In the 2nd row) Open cover, then remove jammed paper.</p>	<p>Paper jam</p> <ol style="list-style-type: none"> <li>(1) The registration sensor detects no paper within the specified time length after the start of paper pulling-in.</li> <li>(2) The registration sensor has been ON for less than the specified time length (paper of approx. 3.15" long) or for more than the specified time length (paper of approx. 16" long).</li> <li>(3) When the machine is switched on or the front cover is opened and then closed, the registration sensor or paper ejection sensor is ON.</li> <li>(4) The paper ejection sensor sticks to ON.</li> <li>(5) The paper ejection sensor does not come ON within the specified time length after the registration sensor has come ON.</li> <li>(6) The paper ejection sensor is kept ON after the specified time length although the registration sensor has come ON.</li> </ol>
<p>(In the 1st row) PLS CLEAN DRUM</p> <p>(In the 2nd row) Clean corona wire of drum unit.</p>	<p>The toner sensor detects abnormal discharge that could be caused by the dirtied corona wire of the drum unit.</p>

Messages on the LCD	Probable Cause
(In the 1st row) CHECK PAPER SIZE  (In the 2nd row) Reload correct paper.	The registration sensor detects that paper shorter than the specified length has been fed.

If only an alarm beep is heard without any message on the LCD when the equipment is powered up, the ROM or RAM will be defective.

[ 2 ] Error codes shown in the "MACHINE ERROR X X" message

Error Code <u>X X</u> (Hex.)	Error factor
( 71	Polygon motor does not synchronize with the reference clock. )
( 72	Cannot detect Beam Detect signal. )
( 73	No toner cartridge loaded. )
( 74	Toner empty. )
( 75	In-casing temperature error. )
( 76	Heater harness disconnected or broken. Or heater thermistor harness disconnected or broken when the power is turned on, the front cover is opened and closed, or the machine exits from the sleep mode. )
( 77	Power turned off and on at the occurrence of error 76 or 78. )
( 78	Heater thermistor short-circuited. Or heater thermistor harness disconnected or broken when the machine is on standby. )
( 79	In-casing temperature sensor harness disconnected or broken. )
( 7A	Main motor does not synchronize with the reference clock. )
( 7B	ASIC error on the main PCB. )
( 7C	Engine PCB error. )
( 7D	Abnormal discharge of the corona wire detected by the toner sensor. )
( 80	Paper size setting error. )
( 82	Paper feeding error. )
( 83	Paper jam. The registration sensor, 2nd registration sensor, and/or manual insertion sensor remains ON.)
( 84	Paper jam. The paper ejection sensor remains ON. )
( 85	No paper cassette loaded. )
( 86	No 2nd paper cassette loaded. )
( 88	Paper jam. Even after the registration sensor has gone OFF, the paper ejection sensor still stays OFF.)
( A1	Front cover opened. )
( A2	Document too long to scan. )
( A3	Document not detected by the document rear sensor. )
( A4	50% or more faulty of white level data. )

Error codes in parentheses do not appear in the "MACHINE ERROR X X", since those errors are displayed as messages described in "[ 1 ] Error messages on the LCD." In the maintenance mode (Function code 82), those error codes may be displayed.

Error Code X X (Hex.)	Error factor
( A7	One-line feeding timeout error. )
( A8	One-line scanning timeout error. )
( A9	Abnormal scanning reference voltage. )
( AC	Less than 50% faulty of white level data. )
( B7	A/D converter reference voltage error (at High level). )
( B8	A/D converter reference voltage error (at Low level). )
( B9	Light emission intensity error of the LED array. )
( BA	Magnification error for substantial white level data. )
( BB	Substantial white level data error in black & white mode. )
( BC	Substantial white level data error in photo mode. )
( BD	Black level data error. )
( D5	The MODEM fails to complete the command transmission sequence. )
( E4	Out of recording paper. )
E6	Write error in EEPROM.
( E8	Data scanning error during transmission. )
( EA	Document removed in phase B.)
( F5	EOL not found in page memory transmission mode. )
( F6	PC interface error. )

Error codes in parentheses do not appear in the "MACHINE ERROR X X", since those errors are displayed as messages described in "[ 1 ] Error messages on the LCD." In the maintenance mode (Function code 82), those error codes may be displayed.

## **1.2 Communications Errors**

If a communications error occurs, the facsimile equipment

- ① emits an audible alarm (intermittent beeping) for approximately 4 seconds,
- ② displays the corresponding error message, and
- ③ prints out the transmission verification report if the equipment is in sending operation.

■ Definition of Error Codes on the Communications List

(1) Calling

Code 1	Code 2	Causes
10	08	Wrong number called.
10	20	Retrieval file error.
10	21	Image data entry error.
11	01	No dial tone detected before start of dialing.
11	02	Busy tone detected before dialing.
11	03	2nd dial tone not detected.
11	05	No loop current detected.*
11	06	Busy tone detected after dialing or called.
11	07	No response from the remote station in sending.
11	10	No tone detected after dialing.
17	07	No response from the calling station in receiving.
1A	01	Calling impossible due to memory full.

\*Available in German versions only.

(2) Command reception

Code 1	Code 2	Causes
20	01	Unable to detect a flag field.
20	02	Carrier was OFF for 200 ms or longer.
20	03	Abort detected ("1" in succession for 7 bits or more).
20	04	Overrun detected.
20	05	A frame for 3 seconds or more received.
20	06	CRC error in answerback.
20	07	Undefined command received.
20	08	Invalid command received.
20	09	Command ignored once for document setting or for dumping-out at turn-around transmission.
20	0A	T5 timeout error
20	0B	CRP received.

Code 1	Code 2	Causes
20	0C	EOR and NULL received.
20	0D	Effective command not received.
20	10	Unable to reserve a command receiver memory.
20	11	Image data file error.

**(3) Compatibility [checking the NSF and DIS]**

Code 1	Code 2	Causes
32	01	Remote terminal only with V.29 capability in 2400 or 4800 bps transmission.
32	02	Remote terminal not ready for polling.
32	10	Remote terminal not equipped with password function or its password switch OFF.
32	11	Remote terminal not equipped with or not ready for confidential mailbox function.
32	12	Remote terminal not equipped with or not ready for relay broadcasting function.
32	13	No confidential mail in the remote terminal.
32	14	The available memory space of the remote terminal is less than that required for reception of the confidential or relay broadcasting instruction.

(4) Instructions received from the remote terminal [checking the NSC, DTC, NSS, and DCS]

Code 1	Code 2	Causes
40	02	Illegal coding system requested.
40	03	Illegal recording width requested.
40	05	ECM requested although not allowed.
40	06	Polled while not ready.
40	07	No document to send when polled.
40	10	Nation code or manufacturer code not coincident.
40	11	Unregistered group code entered for relay broadcasting function, or the specified number of broadcasting subscribers exceeding the limit.
40	12	Retrieval attempted when not ready for retrieval.
40	13	Polled by any other manufacturers' terminal while waiting for secure polling.
40	17	Invalid resolution selected.

(5) Command reception [checking the NSF and DIS after transmission of NSS and DCS]

Code 1	Code 2	Causes
50	01	Vertical resolution capability changed after compensation of background color.



(6) ID checking

Code 1	Code 2	Causes
63	01	Password plus "lower 4 digits of telephone number" not coincident.
63	02	Password not coincident.
63	03	Polling ID not coincident.
63	04	Entered confidential mailbox ID uncoincident with the mailbox ID.
63	05	Relay broadcasting ID not coincident.
63	06	Entered retrieval ID uncoincident with that of the mailbox ID.

(7) DCN reception

Code 1	Code 2	Causes
74		DCN received.

(8) TCF transmission/reception

Code 1	Code 2	Causes
80	01	Fallback impossible.

(9) Signal isolation

Code 1	Code 2	Causes
90	01	Unable to detect video signals and commands within 6 seconds after CFR is transmitted.
90	02	Received PPS containing invalid page count or block count.

(10) Video signal reception

Code 1	Code 2	Causes
A0	03	Error correction sequence not terminated even at the final transmission speed for fallback.
A0	11	Receive buffer empty. (5-second time-out)
A0	12	Receive buffer full during operation except receiving into memory.
A0	13	Decoding error continued on 500 lines.
A0	14	Decoding error continued for 10 seconds.
A0	15	Timeout: Five seconds or more for one-line transmission.
A0	16	RTC not found and carrier OFF signal detected for 6 seconds.
A0	17	RTC found but no command detected for 60 seconds.
A0	18	Receive buffer full during receiving into memory.
A0	19	Unable to obtain compressed image data to be sent in phase C.
A8	01	RTN, PIN, or ERR received at the calling terminal.*
A9	01	RTN, PIN, or ERR received at the called terminal.*

\* Available in German versions only

(11) General communications-related

Code 1	Code 2	Causes
B0	02	Unable to receive the next-page data.
B0	03	Unable to receive polling even during turn-around transmission due to call reservation.
B0	04	PC interface error.
BF	01	Transmission canceled by pressing the <b>Stop</b> key (before completion of the G3 FAX negotiation).
BF	02	Transmission canceled by pressing the <b>Stop</b> key (after completion of the G3 FAX negotiation).
BF	03	Transmission canceled due to a scanning error.

(12) Transmission in V. 34 mode

Code 1	Code 2	Causes
C0	01	No common modulation mode or failed to poll.
C0	02	Unable to detect JM.
C0	03	Unable to detect CM.
C0	04	Unable to detect CJ.
C0	10	Cannot finish V. 34 negotiation or training.
C0	11	Modem error detected during V. 34 negotiation or training. (For modem error details, refer to the table below.)
C0	20	Modem error detected during sending of commands. (For modem error details, refer to the table below.)
C0	21	Modem error detected during receiving of commands. (For modem error details, refer to the table below.)
C0	22	Control channel connection time-out.
C0	30	Modem error detected during sending of video signals. (For modem error details, refer to the table below.)
C0	31	Modem error detected during receiving of video signals. (For modem error details, refer to the table below.)

**Modem error details (Code 3)**

Code 3	Causes
21	Timeout waiting for INFO0.
22	Checksum error in INFO0.
23	Timeout waiting for tone A or B.
24	Timeout waiting for first phase reverse.
25	Timeout waiting for probing cut-off tone.
26	Timeout waiting for second phase reverse.
27	Timeout waiting for end of probing.
28	Timeout waiting for third phase reverse.
29	Timeout waiting for INFO1.
2A	Checksum error in INFO1.
2B	Tone detected preceding INFO0.
2C	Unexpected INFO0 detected.
31	Timeout waiting for turning off the receive control channel.
91	Error occurred in the first CC train.
92	Timeout waiting for PPh.
93	Tone A/B detected in the CC retrain.
94	Timeout waiting for ALT.
95	ACh found.
96	FED turned off during reception of CC data.
97	Timeout waiting for turning off the CC.
A1	Retraining forced for problems not fixed in phase 2.
B0	Problem with S-sequence of HDX-resync.
B1	FED turned off in the S-sequence of HDX-resync.
B2	S-sequence finished before prediction in HDX-resync.
B3	Timeout waiting for S-Sbar in HDX-resync.
B4	Timeout waiting for S-Sbar in HDX-resync.
B5	Timeout waiting for S in HDX-resync.
B6	Timeout waiting for synchronization with PP.
C0	Problem with S-sequence in phase 3.
C1	FED turned off in the S-sequence in phase 3.

Code 3	Causes
C2	S-sequence finished before prediction in phase 3.
C3	Timeout waiting for S-Sbar in phase 3.
C4	Timeout waiting for S-Sbar in phase 3.
C5	Timeout waiting for S in phase 3.
C7	Training after TRN failure.
D0	Problem with S-sequence in phase 4.
D1	FED turned off in S-sequence in phase 4.
D2	S-sequence finished before prediction in phase 4.
D3	Timeout waiting for S-Sbar in phase 4.
D4	Timeout waiting for S-Sbar in phase 4.
D5	Timeout waiting for S in phase 4.
D6	Timeout waiting for MP.
D8	Timeout waiting for E.
DA	Timed out in re-negotiation of the transmitter rate.
DB	Timed out in the transmitter MPh.
E2	Retraining detected in phase 2.
E3	Retraining detected in phase 3.
E4	Retraining detected in phase 4.
FE	DTR turned off during retraining.
FF	Tx set-abort flag.
71	Did not write onto the first mapping frame.

**(13) Maintenance mode**

Code 1	Code 2	Causes
E0	01	Failed to detect 1300 Hz signal in burn-in operation.
E0	02	Failed to detect PB signals in burn-in operation.
E0	03	Failed to detect commands from the RS-232C in burn-in operation.

(14) Equipment error

Code 1	Code 2	Causes
FF	00	Burn-in operation canceled by pressing the <b>Stop</b> key.
FF	FF	Unrecoverable MODEM error.

## 2. TROUBLESHOOTING

### 2.1 Introduction

This section gives the service personnel some of the troubleshooting procedures to be followed if an error or malfunction occurs with the facsimile equipment. It is impossible to anticipate all of the possible problems which may occur in future and determine the troubleshooting procedures, so this section covers some sample problems. However, those samples will help service personnel pinpoint and repair other defective elements if he/she analyzes and examines them well.

### 2.2 Precautions

Be sure to observe the following to prevent the secondary troubles from happening:

- (1) Always unplug the AC power cord from the outlet when removing the covers and PCBs, adjusting the mechanisms, or conducting continuity testing with a circuit tester.
- (2) When disconnecting the connectors, do not pull the lead wires but hold the connector housings.
- (3)
  - Before handling the PCBs, touch a metal portion of the machine to discharge static electricity charged in your body.
  - When repairing the PCBs, handle them with extra care.

After repairing the defective section, be sure to check again if the repaired section works correctly. Also record the troubleshooting procedure so that it would be of use for future trouble occurrence.

### 2.3 Checking prior to Troubleshooting

Prior to proceeding to the troubleshooting procedures given in Subsection 2.4, make the following initial checks:

#### Environmental conditions

Check that:

- (1) The machine is placed on a flat, firm surface.
- (2) The machine is used in a clean environment at or near normal room temperature (10°C to 32.5°C) with normal relative humidity (20 to 80%).
- (3) The machine is not subjected to rapid change of the ambient temperature. (Moving the machine from a cold place to warm place will cause condensation inside the machine. If it takes place, leave the machine in the warm place for approx. two hours before turning on the power.) Powering on the machine with dew condensation will result in damaged electronic devices.
- (4) The machine is not exposed to direct sunlight or harmful gases.

#### Power requirements

Check that:

- (1) The power supply specified on the rating plate located on the bottom of the machine is used. The supply voltage stays within the rating  $\pm 10\%$ .
- (2) Each voltage level on AC input lines and DC lines is correct.

- (3) All cables and harnesses are firmly connected.
- (4) None of the fuses are blown.

Recording paper

Check that:

- (1) A recommended type of recording paper is used.
- (2) The recording paper is not dampened.



## 2.4 Troubleshooting Procedures

### [ 1 ] Control panel related

Trouble	Check:
(1) LCD shows nothing.	<ul style="list-style-type: none"> <li>● Panel-main harness between the main PCB and the control panel PCB</li> <li>● Control panel PCB</li> <li>● Low-voltage power supply PCB</li> <li>● Main PCB</li> <li>● LCD</li> </ul>
(2) Control panel inoperative.	<ul style="list-style-type: none"> <li>● Panel-main harness between the main PCB and the control panel PCB</li> <li>● Control panel PCB</li> <li>● FPC key</li> <li>● Main PCB</li> </ul>

### [ 2 ] Telephone related

Trouble	Check:
(1) No phone call can be made.	<ul style="list-style-type: none"> <li>● FPC key</li> <li>● Control panel PCB</li> <li>● NCU PCB</li> <li>● Main PCB</li> </ul>
(2) Speed dialing or one-touch dialing will not work.	<ul style="list-style-type: none"> <li>● Ordinary dialing function (other than the speed and one-touch dialing)</li> </ul> <p>If it works normally, check the main PCB; if not, refer to item (1) above.</p>
(3) Speaker silent during on-hook dialing.	<ul style="list-style-type: none"> <li>● Ordinary dialing function (other than the on-hook dialing with the hook key)</li> </ul> <p>If it works normally, proceed to the following checks; if not, refer to item (1) above.</p>
(4) Dial does not switch between tone and pulse.	<ul style="list-style-type: none"> <li>● Main PCB</li> </ul>
(5) Telephone does not ring.	<ul style="list-style-type: none"> <li>● Speaker</li> <li>● NCU PCB</li> <li>● Main PCB</li> </ul>

**[ 3 ] Communications related**

Trouble	Check:
(1) No tone is transmitted.	<ul style="list-style-type: none"> <li>● Main PCB</li> <li>● NCU PCB</li> </ul>



**[ 4 ] Paper/document feeding related**

Trouble	Check:
(1) Neither "COPY: PRESS COPY" nor "FAX: NO. & START" message appears although documents are set.	<ul style="list-style-type: none"> <li>● Sensors by using the maintenance-mode function code 32. (Refer to Chapter V, Subsection 3.9.)</li> <li>● Document front sensor actuator and document rear sensor actuator</li> <li>● Main PCB</li> </ul>
(2) Document not fed.	<ul style="list-style-type: none"> <li>● ADF and its related sections</li> <li>● Scanner motor and its harness</li> <li>● Document feed roller and its related gears</li> <li>● Main PCB</li> </ul>
(3) Document double feeding	<ul style="list-style-type: none"> <li>● ADF parts</li> <li>● Nip-related parts</li> </ul>
(4) Recording paper not fed.	<ul style="list-style-type: none"> <li>● Paper loaded in the paper cassette(s)</li> <li>● Paper cassette(s)</li> <li>● Drum unit</li> <li>● Heat-fixing unit</li> <li>● Drive gear ASSY</li> <li>● Engine PCB</li> <li>● Main PCB</li> </ul>
(5) Recording paper double feeding	<ul style="list-style-type: none"> <li>● Separation pad on the paper cassette(s)</li> </ul>

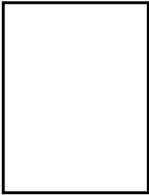

[ 5 ] Print-image related

If the received or sent image has any problem, first make a copy with the facsimile equipment.

If the copied image is normal, the problem may be due to the remote terminal; if it is abnormal, proceed to the following checks:

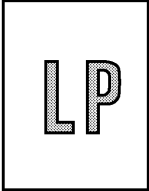
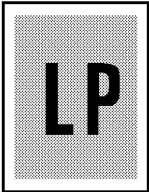
Trouble	Action to be taken
<p>(1) Completely blank</p> 	<p><u>At the scanner</u></p> <p>Check the following components:</p> <ul style="list-style-type: none"> <li>- CIS harness</li> <li>- Main PCB</li> <li>- CIS unit</li> </ul> <p><u>At the printer side</u></p> <ul style="list-style-type: none"> <li>● Clean the high-voltage contacts for the developer roller on the drum unit, main cover, and high-voltage power supply PCB. (Contacts ③ in the illustration given on page VI-28)</li> <li>● Clean the grounding contacts on the drum unit, main cover, and high-voltage power supply PCB. (Contacts ① in the illustration given on page VI-28)</li> <li>● Replace the toner cartridge.</li> <li>● Replace the drum unit.</li> <li>● Check the connection of the laser flat cable on the main PCB.</li> <li>● Replace the main PCB.</li> <li>● Replace the laser unit.</li> <li>● Replace the high-voltage power supply PCB.</li> </ul>
<p>(2) All black</p> 	<p><u>At the scanner</u></p> <p>Check the following components:</p> <ul style="list-style-type: none"> <li>- CIS harness</li> <li>- CIS unit</li> <li>- Main PCB</li> </ul> <p><u>At the printer side</u></p> <ul style="list-style-type: none"> <li>● Clean the high-voltage contacts for the grid and charger on the drum unit, main cover, and high-voltage power supply PCB. (Contacts ④ and ② in the illustration given on page VI-28)</li> <li>● Clean the charger (corona wires) itself.</li> <li>● Check the connection of the laser flat cable on the main PCB.</li> <li>● Replace the drum unit.</li> <li>● Replace the high-voltage power supply PCB.</li> <li>● Replace the main PCB.</li> </ul>

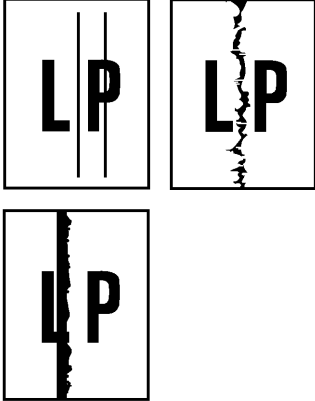
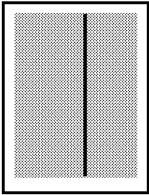
Trouble	Action to be taken
<p>(3) Light</p> 	<p><u>At the scanner</u></p> <p>Check the following components:</p> <ul style="list-style-type: none"> <li>- CIS unit</li> <li>- Main PCB</li> </ul> <p><u>At the printer side</u></p> <ul style="list-style-type: none"> <li>● Replace the toner cartridge with a new one and print 4 to 5 pages. If the problem persists, proceed to the next step.</li> <li>● Remove the toner cartridge and start printing. If printing takes place, clean the toner sensors (LED and light-receiver), check the sensor harnesses, and then replace the toner sensor PCBs.</li> <li>● Clean the high-voltage contacts for the transfer roller on the drum unit, main cover, and high-voltage power supply PCB. (Contacts ⑤ in the illustration given on page VI-28)</li> <li>● Clean the high-voltage contacts for the developer roller on the drum unit, main cover, and high-voltage power supply PCB. (Contacts ③ in the illustration given on page VI-28)</li> <li>● Clean the grounding contacts on the drum unit and main cover. (Contacts ① in the illustration given on page VI-28)</li> <li>● Check the connection of the main PCB and high-voltage power supply PCB.</li> <li>● Replace the drum unit.</li> <li>● Replace the high-voltage power supply PCB.</li> <li>● Replace the engine PCB.</li> <li>● Replace the main PCB.</li> <li>● Replace the laser unit.</li> </ul>
<p>(4) Dark</p> 	<p><u>At the scanner</u></p> <p>Check the following components:</p> <ul style="list-style-type: none"> <li>- CIS unit</li> <li>- Main PCB</li> </ul> <p><u>At the printer side</u></p> <ul style="list-style-type: none"> <li>● Slide the wire cleaner to clean the corona wire inside the drum unit.</li> <li>● Clean the high-voltage contacts for the grid and charger on the drum unit, main cover, and high-voltage power supply PCB. (Contacts ④ and ② in the illustration given on page VI-28)</li> <li>● Replace the toner cartridge.</li> <li>● Replace the drum unit.</li> <li>● Replace the high-voltage power supply PCB.</li> <li>● Replace the main PCB.</li> <li>● Replace the engine PCB.</li> </ul>

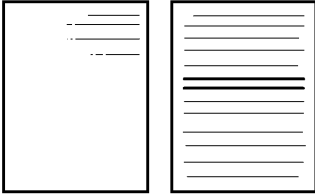

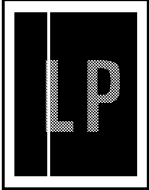
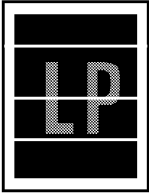
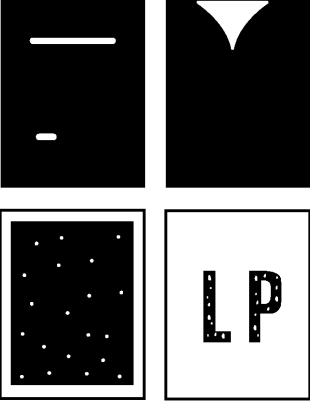
Trouble	Action to be taken
<p>(5) Black and blurred vertical stripes or band</p> 	<p><u>At the scanner</u> Check the following components:</p> <ul style="list-style-type: none"> <li>- CIS unit</li> </ul> <p><u>At the printer side</u></p> <ul style="list-style-type: none"> <li>• Clean the paper path which may be contaminated with toner.</li> <li>• Slide the wire cleaner to clean the corona wire inside the drum unit.</li> <li>• Make sure that the wire cleaner is returned to its home position.</li> <li>• Replace the toner cartridge.</li> <li>• Replace the drum unit.</li> <li>• Replace the heat-fixing unit.</li> </ul>
<p>(6) Black vertical streaks on gray background</p> 	<p><u>At the printer side</u></p> <ul style="list-style-type: none"> <li>• Clean the laser beam window (glass) on the laser unit.</li> <li>• Replace the laser unit.</li> </ul>
<p>(7) Black and blurred horizontal stripes</p> 	<p><u>At the printer side</u></p> <ul style="list-style-type: none"> <li>• Slide the wire cleaner to clean the corona wire inside the drum unit.</li> <li>• If the horizontal stripes appear at 39-mm intervals, replace the toner cartridge.</li> <li>• If they appear at 94-mm intervals, replace the drum unit.</li> <li>• If they appear at 79-mm intervals, replace the heat-fixing unit.</li> <li>• Clean the grounding contacts. (Contacts ① in the illustration given on page VI-28.)</li> <li>• Replace the high-voltage power supply PCB.</li> </ul>
<p>(8) Horizontal lines</p> 	<p><u>At the printer side</u></p> <ul style="list-style-type: none"> <li>• Check the connection between the right end of the paper feed roller and the grounding wire. (Contact ⑦ in the illustration given on page VI-29.)</li> </ul>

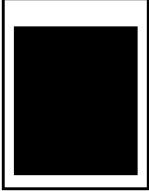
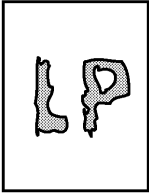
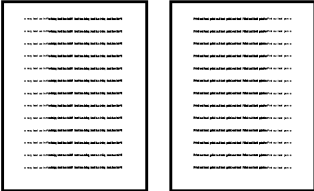
Trouble	Action to be taken
<p>(9) White vertical streaks</p> 	<p><u>At the scanner</u></p> <p>Check the following components:</p> <ul style="list-style-type: none"> <li>- CIS unit</li> </ul> <p><u>At the printer side</u></p> <ul style="list-style-type: none"> <li>• Clean the laser beam window on the laser unit.</li> <li>• Replace the toner cartridge.</li> <li>• Replace the drum unit.</li> </ul>
<p>(10) White horizontal stripes</p> 	<p><u>At the printer side</u></p> <ul style="list-style-type: none"> <li>• Replace the drum unit.</li> </ul>
<p>(11) Dropout, white spots, or hollow print</p> 	<p><u>At the printer side</u></p> <ul style="list-style-type: none"> <li>• Check the connection of the main PCB and high-voltage power supply PCB.</li> <li>• Replace the toner cartridge.</li> <li>• Gently wipe off the surface of the photo-sensitive drum with a cotton swab.</li> <li>• Replace the drum unit.</li> <li>• Replace the high-voltage power supply PCB.</li> </ul>

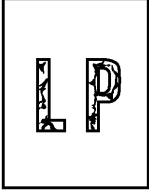
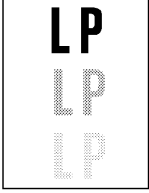
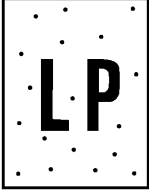
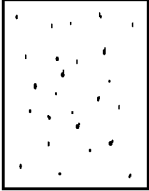
Trouble	Action to be taken
<p>(12) Faulty image registration (Leading edge of image starts too late on paper)</p> 	<p><u>At the printer side</u></p> <ul style="list-style-type: none"> <li>● Instruct the user not to load paper exceeding the limit on the paper cassette(s).</li> <li>● Instruct the user to use the recommended types of paper.</li> <li>● Replace the paper cassette(s).</li> <li>● Check the position of the registration sensor.</li> <li>● Replace the drive gear ASSY.</li> </ul>
<p>(13) Image distortion or improper image alignment</p> 	<p><u>In communications</u></p> <p>Check the following components:</p> <ul style="list-style-type: none"> <li>- Error code displayed. (Refer to Section 1, "ERROR INDICATION" in this chapter.)</li> <li>- NCU PCB</li> <li>- Main PCB</li> </ul> <p><u>At the scanner</u></p> <p>Check the following components:</p> <ul style="list-style-type: none"> <li>- Document take-in roller, separation roller, and their related sections</li> <li>- Document feed roller and its related gears</li> <li>- Scanner motor and its harness</li> <li>- Main PCB</li> </ul> <p><u>At the printer side</u></p> <ul style="list-style-type: none"> <li>● Check that the laser unit is secured with the screws without looseness.</li> <li>● Check the connection of the polygon motor harness on the engine PCB.</li> <li>● Check the connection of the laser flat cable on the main PCB.</li> <li>● Replace the laser unit.</li> </ul>
<p>(14) Blurred at either side</p> 	<p><u>At the printer side</u></p> <ul style="list-style-type: none"> <li>● Check that the equipment is placed on a flat surface.</li> <li>● Shake the toner cartridge horizontally. If the problem persists, replace it.</li> <li>● Clean the laser beam window (glass) on the laser unit.</li> <li>● Replace the laser unit.</li> </ul>

Trouble	Action to be taken
<p>(15) Dirt back of paper</p> 	<p><u>At the printer side</u></p> <ul style="list-style-type: none"> <li>• Clean the pressure roller in the heat-fixing unit. Replace the heat-fixing unit.</li> <li>• Replace the drum unit.</li> <li>• Replace the high-voltage power supply PCB.</li> </ul>
<p>(16) Poor fixing</p> 	<p><u>At the printer side</u></p> <ul style="list-style-type: none"> <li>• Instruct the user to use paper of the recommended weight (less than 36 lb./m<sup>2</sup>).</li> <li>• Clean the toner sensors (LED and light-receiver).</li> <li>• Replace the toner cartridge.</li> <li>• Replace the drum unit.</li> <li>• Check the fitting of the heater thermistor. Replace the heat-fixing unit.</li> <li>• Replace the low-voltage power supply PCB.</li> </ul>
<p>(17) Ghost</p> 	<p><u>At the printer side</u></p> <ul style="list-style-type: none"> <li>• Instruct the user to use paper of the recommended weight (less than 36 lb./m<sup>2</sup>).</li> <li>• Replace the drum unit.</li> <li>• Replace the high-voltage power supply PCB.</li> </ul>
<p>(18) Black spots</p> 	<p><u>At the printer side</u></p> <ul style="list-style-type: none"> <li>• Gently wipe off the surface of the photo-sensitive drum with a cotton swab.</li> <li>• Replace the drum unit.</li> <li>• Replace the heat-fixing unit.</li> <li>• Replace the high-voltage power supply PCB.</li> </ul>
<p>(19) Light rain</p> 	<p><u>At the printer side</u></p> <ul style="list-style-type: none"> <li>• Replace the drum unit.</li> <li>• Replace the high-voltage power supply PCB.</li> </ul>

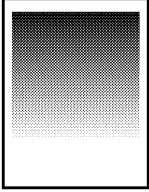
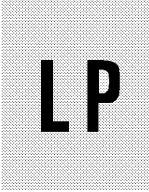

Trouble	Action to be taken
<p>(20) Fading (black to white)</p> 	<p><u>At the printer side</u></p> <ul style="list-style-type: none"> <li>● Replace the toner cartridge.</li> <li>● Replace the high-voltage power supply PCB.</li> </ul>
<p>(21) Gray background</p> 	<p><u>At the printer side</u></p> <ul style="list-style-type: none"> <li>● Instruct the user to use paper of the recommended weight (less than 36 lb./m<sup>2</sup>).</li> <li>● Clean the toner sensors (LED and light-receiver).</li> <li>● Check the toner sensor harnesses.</li> <li>● Replace the toner cartridge.</li> <li>● Replace the drum unit.</li> <li>● Replace the high-voltage power supply PCB.</li> </ul>
<p>(22) Toner specks</p> 	<p><u>At the printer side</u></p> <ul style="list-style-type: none"> <li>● Instruct the user to use paper of the recommended weight (less than 36 lb./m<sup>2</sup>).</li> <li>● Replace the toner cartridge.</li> <li>● Replace the drum unit..</li> </ul>

**Location of High-voltage Contacts and Grounding Contacts**

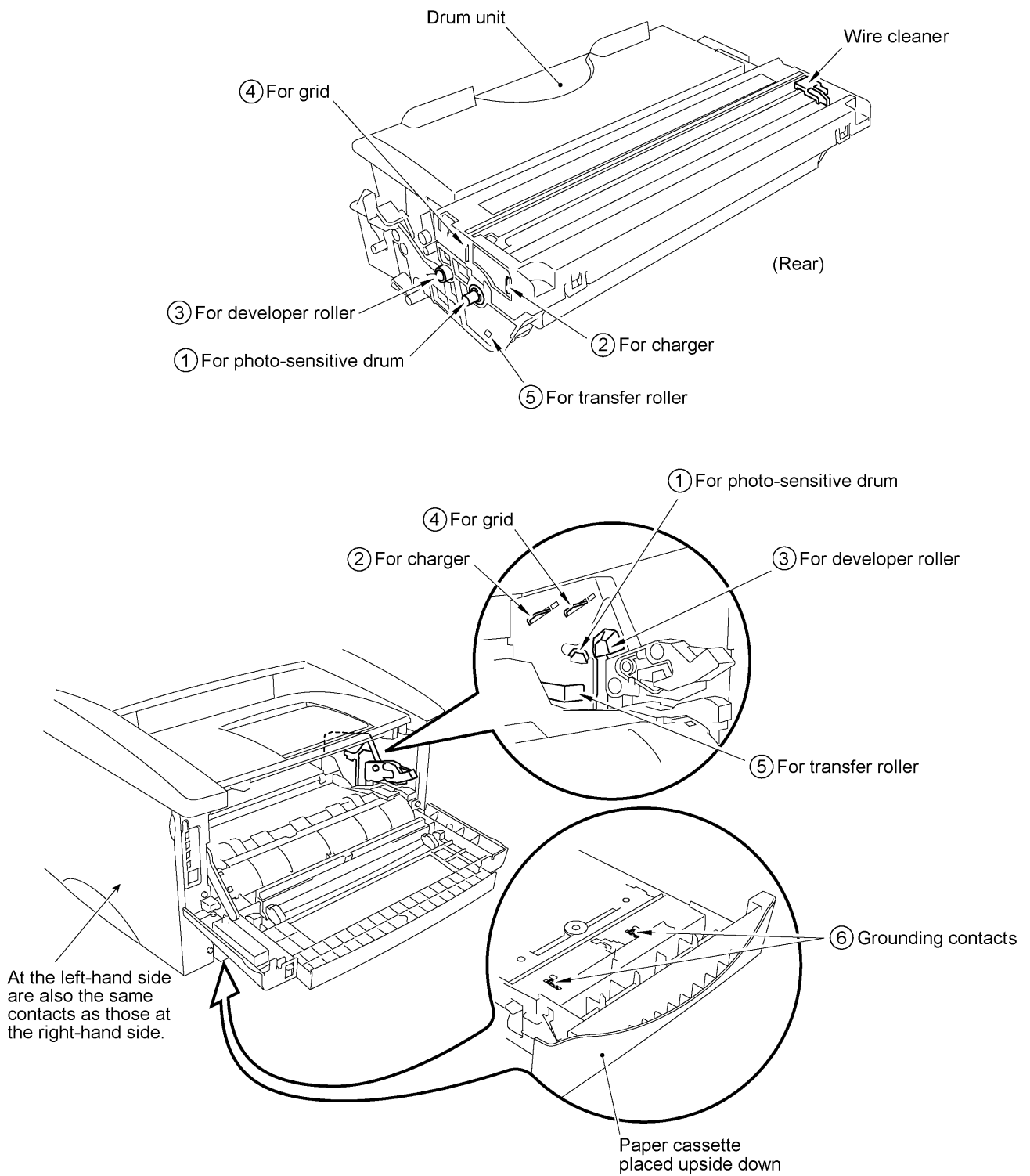

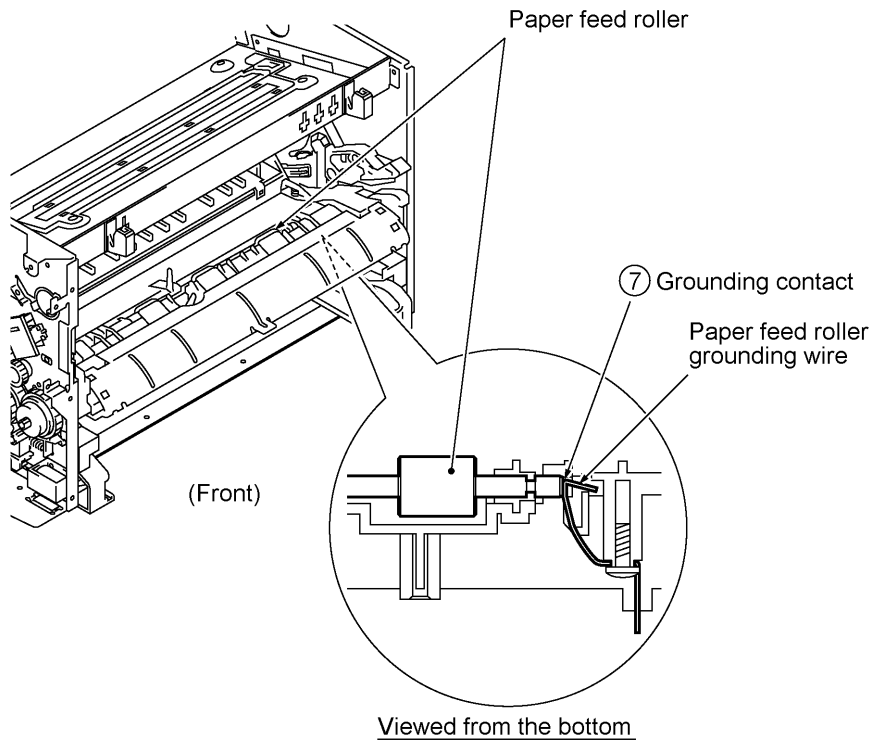

**MFC8500/FAX4100/FAX4750e/FAX5750e  
MFC9660/FAX8360P**

## **Appendix 1. EEPROM Customizing Codes**

## EEPROM Customizing Codes

This function allows you to customize the EEPROM according to language, function settings, and firmware switch settings.

### ■ Operating Procedure

- (1) To make the equipment enter the maintenance mode, press the **Menu**, **\***, **2**, **8**, **6**, and **4** keys in this order.

← Within 2 seconds →

The equipment beeps for approx. one second and displays "■■■ MAINTENANCE ■■■" on the LCD.

- (2) Press the **7** and **4** keys in this order in the initial stage of the maintenance mode.

The current customizing code (e.g., 9001 in the case of MFC8500 USA version) appears.

- (3) Enter the desired customizing code (e.g., 0002 in the case of MFC8500 Canadian version).

The newly entered code appears.

**NOTE:** *If a wrong 4-digit code is entered, the equipment will malfunction.*

- (4) Press the **Fax Start** key.

The equipment saves the setting and returns to the initial stage of the maintenance mode.

If you press the **Stop** key or no keys are pressed for one minute in the above procedure, the equipment stops the procedure and returns to the initial stage of the maintenance mode.

■ **EEPROM Customizing Codes List**

Versions	Model			
	MFC8500	FAX4100	FAX4750e	FAX5750e
U.S.A.	9001	9001	9101	9201
CANADA	0002	-	9102	-

Versions	Model	
	MFC9660	FAX8360P
GERMANY	0003	0003
U.K.	0004	0004
FRANCE	0005	0005
AUSTRALIA	0006	0006
NORWAY	0007	0007
BELGIUM	0008	0008
NETHERLANDS	0009	0009
SWITZERLAND	0010	0010
IRELAND	0004	0004
FINLAND	0012	-
DENMARK	0013	-
AUSTRIA	0003	0003
SPAIN	0015	0015
ITALY	0016	-
SOUTH AFRICA	-	0004
SWEDEN	0026	0026
NEW ZEALAND	0027	0027
ASIA (SINGAPORE)	0040	0040
GENERIC	0050	0050

**MFC8500/FAX4100/FAX4750e/FAX5750e  
MFC9660/FAX8360P**

## **Appendix 2. Firmware Switches (WSW)**

WSW No.	Function	Page
WSW01	Dial pulse setting	2
WSW02	Tone signal setting	3
WSW03	PABX mode setting	4
WSW04	TRANSFER facility setting	6
WSW05	1st dial tone and busy tone detection	7
WSW06	<b>Pause</b> key setting and 2nd dial tone detection	9
WSW07	Dial tone setting 1	11
WSW08	Dial tone setting 2	12
WSW09	Protocol definition 1	13
WSW10	Protocol definition 2	14
WSW11	Busy tone setting	15
WSW12	Signal detection condition setting	16
WSW13	Modem setting	17
WSW14	AUTO ANS facility setting	18
WSW15	REDIAL facility setting	19
WSW16	Function setting 1	20
WSW17	Function setting 2	21
WSW18	Function setting 3	22
WSW19	Transmission speed setting in V. 17 mode	23
WSW20	Overseas communications mode setting	24
WSW21	TAD setting 1	25
WSW22	ECM setting	25
WSW23	Communications setting	26
WSW24	TAD setting 2	27
WSW25	TAD setting 3	28
WSW26	Function setting 4	29
WSW27	Function setting 5	30
WSW28	Function setting 6	31
WSW29	Function setting 7	32
WSW30	Function setting 8	32
WSW31	Function setting 9	33
WSW32	Function setting 10	34
WSW33	Function setting 11	34
WSW34	Function setting 12	35
WSW35	Function setting 13	35
WSW36	Function setting 14	36
WSW37	Function setting 15	37
WSW38	Function setting 16, in V. 34 mode	38
WSW39	Transmission speed setting in V. 34 mode	39
WSW40	Function setting 17, in V. 34 mode	40
WSW41	CCD fluorescent lamp and modem attenuator, in V. 34 mode	42
WSW42	Function setting 18	43
WSW43	Function setting 19	44
WSW44	Speeding up scanning-1	44
WSW45	Speeding up scanning-2	45
WSW46	Monitor of power ON/OFF state and parallel port kept at high	46
WSW47	Delay of FAX line disconnection	47
WSW48 to 50	Not used.	47



WSW01 (Dial pulse setting)

Selector No.	Function	Setting and Specifications
1 2	Dial pulse generation mode	No. 1 2 0 0 : N 0 1 : N+1 1 0 : 10-N 1 1 : N
3 4	Break time length in pulse dialing	No. 3 4 0 0 : 60 ms 0 1 : 67 ms 1 0 : 40 ms (for 16 PPS) 1 1 : 64 ms (at 106-ms intervals)
5 6	Inter-digit pause	No. 5 6 0 0 : 800 ms 0 1 : 850 ms 1 0 : 950 ms 1 1 : 600 ms
7	Switching between pulse (DP) and tone (PB) dialing, by the function switch	0: Yes                      1: No
8	Default dialing mode, pulse (DP) or tone (PB) dialing	0: PB                      1: DP

**NOTE:** In models supporting no pulse (DP) dialing mode (e.g., U.S.A. version), selector 7 takes no effect even if it may be set.

• **Selectors 1 and 2: Dial pulse generation mode**

These selectors set the number of pulses to be generated in pulse dialing.

N: Dialing "N" generates "N" pulses. (Dialing "0" generates 10 pulses.)

N + 1: Dialing "N" generates "N + 1" pulses.

10 - N: Dialing "N" generates "10 - N" pulses.

• **Selectors 3 and 4: Break time length in pulse dialing**

These selectors set the break time length in pulse dialing.

(Example: If "1," "2," and "3" are dialed when N is set by selectors 1 and 2.)

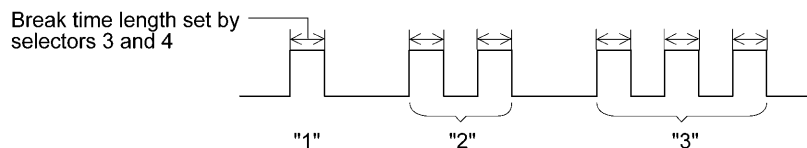

• **Selectors 5 and 6: Inter-digit pause**

These selectors set the inter-digit pause in pulse dialing.

(Example: If "1," "2," and "3" are dialed when N is set by selectors 1 and 2.)

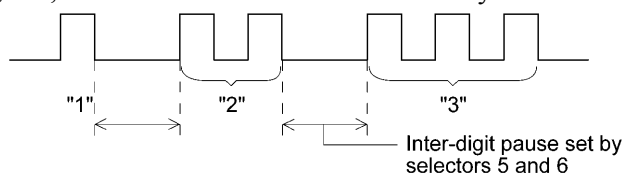

- Selector 7: Switching between pulse (DP) and tone (PB) dialing, by the function switch**  
 This selector determines whether or not the dialing mode may be switched between the pulse (DP) and tone (PB) dialing by using the function switch.
- Selector 8: Default dialing mode, pulse (DP) or tone (PB) dialing**  
 This selector sets the default dialing mode (pulse dialing or tone dialing) which may be changed by the function switch. If the user switches it with the function switch when selector 7 is set to "0," the setting specified by this selector will also be switched automatically.

**WSW02 (Tone signal setting)**

Selector No.	Function	Setting and Specifications
1 2	Tone signal transmission time length	No. 1 2 0 0 : 70 ms 0 1 : 80 ms 1 0 : 90 ms 1 1 : 100 ms
3 4	Min. pause in tone dialing	No. 3 4 0 0 : 70 ms 0 1 : 80 ms 1 0 : 90 ms 1 1 : 140 ms
5   8	Attenuator for pseudo ring backtone to the line (selectable in the range of 0-15 dB)	0 : 0 dB    1: 8 dB 0 : 0 dB    1: 4 dB 0 : 0 dB    1: 2 dB 0 : 0 dB    1: 1 dB

- Selectors 1 through 4: Tone signal transmission time length and Min. pause in tone dialing**  
 These selectors set the tone signal transmission time length and minimum pause in tone dialing. (Example: If "1," "2," "3," "4," and "5" are dialed.)

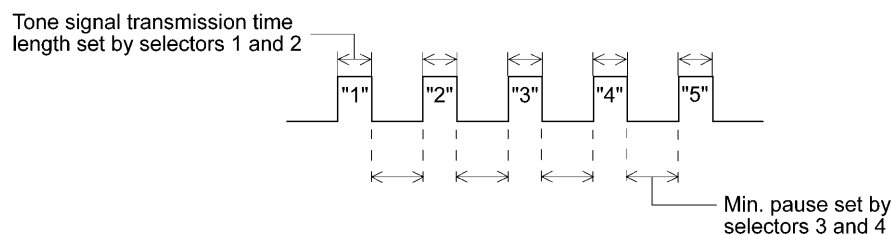

- Selectors 5 through 8: Attenuator for pseudo ring backtone to the line**  
 These selectors are used to adjust the sound level of beep generated as a ring backtone in the F/T mode or as a signal during remote control operation or at the start of ICM recording. Setting two or more selectors to "1" produces addition of attenuation assigned to each selector.

WSW03 (PABX\* mode setting)

Selector No.	Function	Setting and Specifications
1	CNG detection when sharing a modular wall socket with a telephone	0: A      1: B
2   4	Min. detection time length of PABX* dial tone, required for starting dialing	No. 2 3 4 0 0 0 : 50 ms 0 0 1 : 210 ms 0 1 0 : 500 ms 0 1 1 : 800 ms 1 0 0 : 900 ms 1 0 1 : 1.5 sec. 1 1 0 : 2.0 sec. 1 1 1 : 2.5 sec.
5	CNG detection when sharing a modular wall socket with a telephone	0: A      1: B
6 7	Dial tone detection in PABX*	No. 6 7 0 0 : No detection (3.5 sec. WAIT) 0 1 : No detection (5 sec. WAIT) 1 0 : No detection (7 sec. WAIT) 1 1 : Detection (Frequency only)
8	Not used.	

\* PABX: Private automatic branch exchange

**NOTE:** Selectors 2 through 4, 6 and 7 are not applicable where no PABX is installed.

● **Selectors 1 and 5: CNG detection when sharing a modular wall socket with a telephone**

These selectors determine whether or not the equipment detects a CNG signal when a line is connected to a telephone sharing a modular wall socket with the equipment. Upon detection of CNG signals by the number of cycles specified by these selectors, the equipment interprets CNG as an effective signal and then starts FAX reception.

Selector		Cycle
No. 1	No. 5	
0 (A)	0 (A)	0.5 cycle
0 (A)	1 (B)	1.0 cycle
1 (B)	0 (A)	1.5 cycles
1 (B)	1 (B)	2.0 cycles

● **Selectors 2 through 4: Min. detection time length of PABX dial tone, required for starting dialing**

Upon detection of the PABX dial tone for the time length set by these selectors, the equipment starts dialing.

These selectors are effective only when both selectors 6 and 7 are set to "1" (Detection).

- **Selectors 6 and 7: Dial tone detection in PABX**

These selectors activate or deactivate the dial tone detection function which detects a dial tone when a line is connected to the PABX.

Setting both of these selectors to "1" activates the dial tone detection function so that the equipment starts dialing upon detection of a dial tone when a line is connected.

Other setting combinations deactivate the dial tone detection function so that the equipment starts dialing after the specified WAIT (3.5, 5.0, or 7.0 sec.) without detection of a dial tone when a line is connected.

WSW04 (TRANSFER facility setting)

Selector No.	Function	Setting and Specifications
1	Earth function in transfer facility	0: Provided      1: Not provided
2   4	Not used.	
5  6	Earth time length for earth function	No. 5 6 0 0 : 200 ms 0 1 : 300 ms 1 0 : 500 ms 1 1 : 700 ms
7  8	Break time length for flash function	No. 7 8 0 0 : 80 ms 0 1 : 110 ms 1 0 : 250 ms 1 1 : 500 ms

**NOTE:** Selectors 5 through 8 are not applicable in those countries where no transfer facility is supported.

- **Selector 1: Earth function in transfer facility**

This selector determines whether or not the earth function is added to the transfer setting menu to be accessed by the function switch.

- **Selectors 5 and 6: Earth time length for earth function**

These selectors set the short-circuiting time length of the telephone line (La or Lb) to ground.

This setting is effective only when the earth function is selected for the R key by using the function switch.

- **Selectors 7 and 8: Break time length for flash function**

These selectors set the break time length.

This setting is effective only when the flash function is selected for the R key by using the function switch.

## WSW05 (1st dial tone and busy tone detection)

Selector No.	Function	Setting and Specifications
1   3	1st dial tone detection	No. 1 2 3 0 0 0 : 3.5 sec. WAIT 0 0 1 : 7.0 sec. WAIT 0 1 0 : 10.5 sec. WAIT 0 1 1 : 14.0 sec. WAIT 1 0 0 : 17.5 sec. WAIT 1 0 1 : 21.0 sec. WAIT 1 1 0 : 24.5 sec. WAIT 1 1 1 : Detection (Without WAIT)
4	Max. pause time allowable for remote ID code detection	0 : 2 seconds      1: 1 second
5 6	Busy tone detection in automatic sending mode	No. 5 6 0 0 : No detection 0 1 : Detection only after dialing 1 0 : No detection 1 1 : Detection before and after dialing
7	Busy tone detection in automatic receiving mode	0: Yes              1: No
8	Not used.	

**NOTE:** Selectors 5 through 7 are not applicable in those countries where no busy tone detection is supported.

- **Selectors 1 through 3: 1st dial tone detection**

These selectors activate or deactivate the 1st dial tone detection function which detects the 1st dial tone issued from the PSTN when a line is connected to the PSTN.

Setting all of these selectors to "1" activates the dial tone detection function so that the equipment starts dialing upon detection of a dial tone when a line is connected. For the detecting conditions of the 1st dial tone, refer to WSW07 and WSW08.

Other setting combinations deactivate the dial tone detection function so that the equipment starts dialing after the specified WAIT (3.5, 7.0, 10.5, 14.0, 17.5, 21.0, or 24.5 seconds) without detection of a dial tone when a line is connected to the PSTN.

- **Selector 4: Max. pause time allowable for remote ID code detection**

This selector sets the maximum pause time allowable for detecting the second digit of a remote ID code after detection of the first digit in remote reception.

If selector 4 is set to "0" (2 seconds), for instance, only a remote ID code whose second digit is detected within 2 seconds after detection of the first digit will become effective so as to activate the remote function.

- **Selectors 5 and 6: Busy tone detection in automatic sending mode**

These selectors determine whether or not the equipment automatically disconnects a line upon detection of a busy tone in automatic sending mode.

Setting selector 6 to "0" ignores a busy tone so that the equipment does not disconnect the line.

Setting selectors 5 and 6 to "0" and "1," respectively, makes the equipment detect a busy tone only after dialing and disconnect the line.

Setting both of selectors 5 and 6 to "1" makes the equipment detect a busy tone before and after dialing and then disconnect the line.

- **Selector 7: Busy tone detection in automatic receiving mode**

This selector determines whether or not the equipment automatically disconnects a line upon detection of a busy tone in automatic receiving mode.

WSW06 (Pause key setting and 2nd dial tone detection)

Selector No.	Function	Setting and Specifications
1   3	Pause key setting and 2nd dial tone detection	No. 1 2 3 0 0 0 : No pause 0 0 1 : 3.5 sec. WAIT 0 1 0 : 7 sec. WAIT 0 1 1 : 10.5 sec. WAIT 1 0 0 : 14 sec. WAIT 1 1 0 : 2nd dial tone detection only in pulse dialing (DP) system 1 0 1 : } 2nd dial tone detection 1 1 1 : } both in DP and push-button (PB) dialing system
4   6	Detection of 2nd dial tone	No. 4 5 6 0 0 0 : 50 ms 0 0 1 : 210 ms 0 1 0 : 500 ms 0 1 1 : 800 ms 1 0 0 : 900 ms 1 0 1 : 1.5 sec. 1 1 0 : 2.0 sec. 1 1 1 : 2.5 sec.
7	No. of 2nd dial tone detection times	0: Once      1: Twice
8	2nd dial tone interrupt detecting time	0: 30 ms      1: 50 ms



● **Selectors 1 through 3: Pause key setting and 2nd dial tone detection**

Selectors			
1	2	3	
0	0	0	No WAIT is inserted even if the <b>Pause</b> key is pressed.
0	0	1	If you press the <b>Pause</b> key during dialing, the facsimile equipment will insert WAIT as defined in the above table. If the <b>Pause</b> key is pressed repeatedly, the equipment inserts the specified WAIT multiplied by the number of depressions. It applies also in hook-up dialing.
0	1	0	
0	1	1	
1	0	0	
1	0	1	When these selectors are set to "1, 0, 1": If you press the <b>Pause</b> key during dialing, the equipment will wait for the 2nd dial tone to be sent via the communications line. When these selectors are set to "1, 1, 0" or "1, 1, 1": If you press the <b>Pause</b> key during dialing, the equipment will first wait for the 2nd dial tone to be sent via the communications line. After that, the equipment will insert a WAIT of 3.5 seconds. If no 2nd dial tone is received within the specified time length (set by WSW08), the equipment will disconnect the line if in automatic dialing, or it will start transmitting the dial signal if given after depression of the <b>Pause</b> key in hook-up dialing.
1	1	0	
1	1	1	

● **Selectors 4 through 6: Detection of 2nd dial tone**

Upon detection of the 2nd dial tone for the time length specified by these selectors, the equipment starts dialing.

This setting is effective only when the 2nd dial tone detection function is activated by selectors 1 through 3 (Setting 101, 110, or 111).

This function does not apply in those countries where no dial tone detection function is supported.

● **Selector 7: No. of 2nd dial tone detection times**

This selector sets the number of dial tone detection times required for starting dialing.

● **Selector 8: 2nd dial tone interrupt detecting time**

This selector sets the allowable time length of an interrupt which should not be interpreted as an interrupt in the 2nd tone dialing.

## WSW07 (Dial tone setting 1)

Selector No.	Function	Setting and Specifications
1 2	Frequency band range	No. 1 2 0 0 : Narrows by 10 Hz 0 1 : Initial value 1 X : Widens by 10 Hz
3	Line current detection	0: No      1: Yes
4   6	2nd dial tone detection level (Z = 600 Ω)	No. 4 5 6 0 0 0 : -21 dBm 0 0 1 : -24 dBm 0 1 0 : -27 dBm 0 1 1 : -30 dBm 1 0 0 : -33 dBm 1 0 1 : -36 dBm 1 1 0 : -39 dBm 1 1 1 : -42 dBm
7	1st dial tone interrupt detecting time	0: 30 ms      1: 50 ms
8	Not used.	

**NOTE:** Selectors 1 through 7 are not applicable in those countries where no dial tone or line current detection is supported, e.g., U.S.A.

- **Selectors 1 and 2: Frequency band range**

These selectors set the frequency band for the 1st dial tone and the busy tone (before dialing) to be detected.

This setting is effective only when selectors 1 through 3 of WSW05 are set to "1,1,1."

- **Selector 3: Line current detection**

This selector determines whether or not the equipment should detect a line current before starting dialing.

- **Selectors 4 through 6: 2nd dial tone detection level**

These selectors set the detection level of the 2nd dial tone.

- **Selector 7: 1st dial tone interrupt detecting time**

This selector sets the allowable time length of an interrupt which should not be interpreted as an interrupt in the 1st dial tone dialing.

## WSW08 (Dial tone setting 2)

Selector No.	Function	Setting and Specifications
1   3	1st dial tone detection time length	No. 1 2 3 0 0 0 : 50 ms 0 0 1 : 210 ms 0 1 0 : 500 ms 0 1 1 : 800 ms 1 0 0 : 900 ms 1 0 1 : 1.5 sec. 1 1 0 : 2.0 sec. 1 1 1 : 2.5 sec.
4 5	Time-out length for 1st and 2nd dial tone detection	No. 4 5 0 0 : 10 sec. 0 1 : 20 sec. 1 0 : 15 sec. 1 1 : 30 sec.
6   8	Detection level of 1st dial tone and busy tone before dialing	No. 6 7 8 0 0 0 : -21 dBm 0 0 1 : -24 dBm 0 1 0 : -27 dBm 0 1 1 : -30 dBm 1 0 0 : -33 dBm 1 0 1 : -36 dBm 1 1 0 : -39 dBm 1 1 1 : -42 dBm

**NOTE:** The WSW08 is not applicable in those countries where no dial tone detection is supported, e.g., U.S.A.

- **Selectors 1 through 3: 1st dial tone detection time length**

Upon detection of the 1st dial tone for the time length set by these selectors, the equipment starts dialing.

This setting is effective only when selectors 1 through 3 of WSW05 are set to "1,1,1."

- **Selectors 4 and 5: Time-out length for 1st and 2nd dial tone detection**

These selectors set the time-out length for the 1st and 2nd dial tone detection so that the equipment waits dial tone input for the specified time length and disconnects itself from the line when no dial tone is inputted.

## WSW09 (Protocol definition 1)

Selector No.	Function	Setting and Specifications	
1	Frame length selection	0: 256 octets    1: 64 octets	
2	Use of non-standard commands	0: Allowed    1: Prohibited	
3 4	No. of retries	No. 3 4 0 0 : 4 times 0 1 : 3 times 1 0 : 2 times 1 1 : 1 time	
5		T5 timer	0: 300 sec.    1: 60 sec.
6		T1 timer	0: 35 sec.    1: 40 sec.
7 8		Elapsed time for time-out control for no response from the called station in automatic sending mode	No. 7 8 0 0 : 60 sec. (55 sec. for US and Canada) 0 1 : 140 sec. 1 0 : 90 sec. 1 1 : 35 sec.

**NOTE:** Selectors 1 through 6 are not applicable in those models which do not support ECM.

- **Selector 1: Frame length selection**

Usually a single frame consists of 256 octets (1 octet = 8 bits). For communications lines with higher bit error rate, however, set selector 1 to "1" so that the facsimile equipment can divide a message into 64-octet frames.

Remarks: The error correction mode (ECM) is a facsimile transmission manner in which the equipment divides a message into frames for transmission so that if any data error occurs on the transmission line, the equipment retransmits only those frames containing the error data.

- **Selector 2: Use of non-standard commands**

If this selector is set to "0," the equipment may use non-standard commands (the machine's native-mode commands, e.g., NSF, NSC, and NSS) for communications. If it is set to "1," the equipment will use standard commands only.

- **Selectors 3 and 4: No. of retries**

These selectors set the number of retries in each specified modem transmission speed.

- **Selector 5: T5 timer**

This selector sets the time length for the T5 timer.

- **Selector 6: T1 timer**

This selector sets the time length for the T1 timer.

- **Selectors 7 and 8: Elapsed time for time-out control**

If the equipment receives no response (no G3 command) from the called terminal in automatic sending during the time set by these selectors, it disconnects the line.

## WSW10 (Protocol definition 2)

Selector No.	Function	Setting and Specifications
1	Switching of DPS, following the CML ON/OFF	0: No      1: Yes
2	Time length from transmission of the last dial digit to CML ON	0: 100 ms      1: 50 ms
3	Time length from CML ON to CNG transmission	0: 2 sec.      1: 4 sec.
4	Time length from CML ON to CED transmission (except for facsimile-to-telephone switching)	0: 0.5 sec.      1: 2 sec.
5 6	No. of training retries	No. 5    6 0    0    :    1 time 0    1    :    2 times 1    0    :    3 times 1    1    :    4 times
7	Encoding system (Compression)	MR      0: Allowed      1: Not allowed
8		MMR      0: Allowed      1: Not allowed

- Selector 1: Switching of DPS, following the CML ON/OFF**  
 Setting this selector to "1" automatically switches DPS following the CML ON/OFF operation.
- Selector 2: Time length from transmission of the last dial digit to CML ON**  
 This selector sets the time length from when the equipment transmits the last dial digit until the CML relay comes on.
- Selector 3: Time length from CML ON to CNG transmission**  
 This selector sets the time length until the equipment transmits a CNG after it turns on the CML relay.
- Selector 4: Time length from CML ON to CED transmission**  
 This selector sets the time length until the equipment transmits a CED after it turns on the CML relay. This setting does not apply to switching between facsimile and telephone.
- Selectors 5 and 6: No. of training retries**  
 These selectors set the number of training retries to be repeated before automatic fallback.
- Selectors 7 and 8: Encoding system (Compression)**  
 This selector determines whether or not use of the MR/MMR coding system will be allowed.

## WSW11 (Busy tone setting)

Selector No.	Function	Setting and Specifications
1 2	Frequency band range	No. 1 2 0 0 : Narrows by 10 Hz 0 1 : Initial value 1 x : Widens by 10 Hz
3	Not used.	
4	ON/OFF time length ranges (More than one setting allowed)	1: 400-600/400-600 ms
5		1: 175-440/175-440 ms
6		1: 100-1000/17-660 ms
7		1: 110-410/320-550 ms
8		1: 100-660/100-660 ms

**NOTE:** WSW11 is not applicable in those countries where no busy tone detection is supported.

**NOTE:** The setting of WSW11 is effective only when selectors 5 and 6 of WSW05 are set to "0, 1" or "1, 1" (Busy tone detection).

- **Selectors 1 and 2: Frequency band range**

These selectors set the frequency band for busy tone to be detected.

- **Selectors 4 through 8: ON/OFF time length ranges**

These selectors set the ON and OFF time length ranges for busy tone to be detected. If more than one selector is set to "1," the ranges become wider. For example, if selectors 4 and 5 are set to "1," the ON and OFF time length ranges are from 175 to 600 ms.

**WSW12 (Signal detection condition setting)**

Selector No.	Function	Setting and Specifications
1 2	Min. OFF time length of calling signal (Ci)	No. 1 2 0 0 : 1500 ms 0 1 : 500 ms 1 0 : 700 ms 1 1 : 900 ms
3 4	Max. OFF time length of calling signal (Ci)	No. 3 4 0 0 : 6 sec. 0 1 : 7 sec. 1 0 : 9 sec. 1 1 : 11 sec.
5 6	Detecting time setting	No. 5 6 0 0 : 800 ms 0 1 : 200 ms 1 0 : 250 ms 1 1 : 150 ms
7	Delay	0: Yes      1: No
8	Not used.	

● **Selectors 1 through 4: Min. and max. OFF time length of calling signal (Ci)**

If the equipment detects the OFF state of calling signal (Ci) for a time length which is greater than the value set by selectors 1 and 2 and less than the value set by selectors 3 and 4, then it interprets the Ci signal as OFF.

● **Selectors 5 and 6: Detecting time setting**

These selectors set the time length required to make the equipment acknowledge itself to be called. That is, if the equipment continuously detects calling signals with the frequency set by selectors 1 through 4 of WSW14 during the time length set by these selectors 5 and 6, it acknowledges the call.

● **Selector 7: Delay**

Setting this selector to "0" allows the equipment to insert a 900 ms WAIT after acknowledgment of the call until the equipment turns on the CML relay to start receiving operation.

## WSW13 (Modem setting)

Selector No.	Function	Setting and Specifications
1 2	Cable equalizer	No. 1 2 0 0 : 0 km 0 1 : 1.8 km 1 0 : 3.6 km 1 1 : 5.6 km
3 4	Reception level	No. 3 4 0 0 : -43 dBm 0 1 : -47 dBm 1 0 : -49 dBm 1 1 : -51 dBm
5   8	Modem attenuator	0: 0 dB            1: 8 dB 0: 0 dB            1: 4 dB 0: 0 dB            1: 2 dB 0: 0 dB            1: 1 dB

The modem should be adjusted according to the user's line conditions.

- **Selectors 1 and 2: Cable equalizer**

These selectors are used to improve the pass-band characteristics of analogue signals on a line. (Attenuation in the high-band frequency is greater than in the low-band frequency.)

Set these selectors according to the distance from the telephone switchboard to the facsimile equipment.

- **Selectors 3 and 4: Reception level**

These selectors set the optimum receive signal level.

- **Selectors 5 through 8: Modem attenuator**

These selectors are used to adjust the transmitting level of the modem when the reception level at the remote station is improper due to line loss. This function applies to G3 protocol signals.

Setting two or more selectors to "1" produces addition of attenuation assigned to each selector.

This setting will be limited if selector 8 of WSW23 is set to "0."



WSW14 (AUTO ANS facility setting)

Selector No.	Function	Setting and Specifications
1 2	Frequency band selection (Lower limit)	No. 1 2 0 0 : 13 Hz 0 1 : 15 Hz 1 0 : 23 Hz 1 1 : 20 Hz
3 4	Frequency band selection (Upper limit)	No. 3 4 0 0 : 30 Hz 0 1 : 55 Hz 1 0 : 70 Hz 1 1 : 200 Hz
5   8	No. of rings in AUTO ANS mode	No. 5 6 7 8 0 0 0 0 : Fixed to once 0 0 0 1 : Fixed to 2 times 0 0 1 0 : Fixed to 3 times 0 0 1 1 : Fixed to 4 times 0 1 0 0 : 1 to 2 times 0 1 0 1 : 1 to 3 times 0 1 1 0 : 1 to 4 times 0 1 1 1 : 1 to 5 times 1 0 0 0 : 2 to 3 times 1 0 0 1 : 2 to 4 times 1 0 1 0 : 2 to 5 times 1 0 1 1 : 2 to 6 times 1 1 0 0 : 1 to 10 times 1 1 0 1 : 2 to 10 times 1 1 1 0 : 3 to 5 times 1 1 1 1 : 4 to 10 times

● **Selectors 1 through 4: Frequency band selection**

These selectors are used to select the frequency band of calling signals for activating the AUTO ANS facility.

In the French versions, if the user sets the PBX to OFF from the control panel, the setting made by selectors 1 and 2 will take no effect and the frequency's lower limit will be fixed to 32 Hz. (Even if the setting made by these selectors does not apply, it will be printed on the configuration list.)

● **Selectors 5 through 8: No. of rings in AUTO ANS mode**

These selectors set the number of rings to initiate the AUTO ANS facility.

WSW15 (REDIAL facility setting)

Selector No.	Function	Setting and Specifications
1 2	Selection of redial interval	No. 1 2 0 0 : 5 minutes 0 1 : 1 minute 1 0 : 2 minutes 1 1 : 3 minutes
3   6	No. of redialings	No. 3 4 5 6 0 0 0 0 : 16 times 0 0 0 1 : 1 times 0 0 1 0 : 2 times 0 0 1 1 : 3 times     1 1 1 1 : 15 times
7	Redialing for no response sent from the called terminal	0: Redialing 1: No redialing
8	Not used.	

**NOTE:** Selector 7 is not applicable in those countries where no busy tone detection is supported.

- **Selectors 1 through 6: Selection of redial interval and No. of redialings**

The equipment redials by the number of times set by selectors 3 through 6 at intervals set by selectors 1 and 2.

This setting is effective only when selector 7 is set to "0."

- **Selectors 7: Redialing for no response sent from the called terminal**

This selector determines whether or not the equipment redials if no G3 command response comes from the called station after dialing within the time length set by selectors 7 and 8 of WSW09.

WSW16 (Function setting 1)

Selector No.	Function	Setting and Specifications
1	Not used.	
2	CCITT superfine recommendation	0: OFF                      1: ON
3   6	Not used.	
7	Max. document length limitation	0: 400 cm                      1: 90 cm
8	<b>Stop</b> key pressed during reception	0: Not functional      1: Functional

- **Selector 2: CCITT superfine recommendation**

If this selector is set to "1," the equipment communicates in CCITT recommended superfine mode (15.4 lines/mm). If it is set to "0," it communicates in native superfine mode.

- **Selector 7: Max. document length limitation**

This selector is used to select the maximum length of a document to be sent.

- **Selector 8: Stop key pressed during reception**

If this selector is set to "1," pressing the **Stop** key can stop the current receiving operation. The received data will be lost.

## WSW17 (Function setting 2)

Selector No.	Function	Setting and Specifications
1 2	Off-hook alarm	No. 1 2 0 0 : No alarm 0 1 : Always valid 1 X : Valid except when 'call reservation' is selected.
3 4	Not used.	
5	Calendar clock type	0: U.S.A. type 1: European type
6	Not used.	
7	Non-ring reception	0: OFF 1: ON
8	Not used.	

- **Selectors 1 and 2: Off-hook alarm**

These selectors activate or deactivate the alarm function which sounds an alarm when the communication is completed with the handset being off the hook.

- **Selector 5: Calendar clock type**

If this selector is set to "0" (USA), the MM/DD/YY hh:mm format applies; if it is set to "1" (Europe), the DD/MM/YY hh:mm format applies: DD is the day, MM is the month, YY is the last two digits of the year, hh is the hour, and mm is the minute.

- **Selector 7: Non-ring reception**

Setting this selector to "1" makes the equipment receive calls without ringer sound if the ring delay is set to 0.

WSW18 (Function setting 3)

Selector No.	Function	Setting and Specifications
1	Not used.	
2 3	Detection enabled time for CNG and no tone	No. 2 3 0 0 : 40 sec. 0 1 : 0 sec. (No detection) 1 0 : 5 sec. 1 1 : 80 sec.
4 5	Not used.	
6	Registration of station ID	0: Permitted 1: Prohibited
7 8	Tone sound monitoring	No. 7 8 0 X : No monitoring 1 0 : Up to phase B at the calling station only 1 1 : All transmission phases both at the calling and called stations

- **Selectors 2 and 3: Detection enabled time for CNG and no tone**

After the line is connected via the external telephone or by picking up the handset of the facsimile equipment, the equipment can detect a CNG signal or no tone for the time length specified by these selectors. The setting specified by these selectors becomes effective only when selector 8 of WSW20 is set to "1."

- **Selectors 7 and 8: Tone sound monitoring**

These selectors set monitoring specifications of the tone sound inputted from the line.

## WSW19 (Transmission speed setting in V. 17 mode)

Selector No.	Function	Setting and Specifications
1   3	First transmission speed choice for fallback	No. 1 2 3 No. 4 5 6 0 0 0 : 2,400 bps 0 0 1 : 4,800 bps 0 1 0 : 7,200 bps 0 1 1 : 9,600 bps 1 0 0 : 12,000 bps 1 0 1 : } 1 1 0 : } 14,400 bps 1 1 1 : }
4   6	Last transmission speed choice for fallback	
7	V. 34 mode	0: Permitted 1: Prohibited
8	V. 17 mode	0: Permitted 1: Prohibited

**NOTE:** For the transmission speed setting in V.34 mode, refer to WSW39.

- **Selectors 1 through 6: First and last choices of transmission speed for fallback**

These selectors are used to set the modem speed range. With the first transmission speed choice specified by selectors 1 through 3, the equipment attempts to establish the transmission link via the modem. If the establishment fails, the equipment automatically steps down to the next highest speed and attempts to establish the transmission link again. The equipment repeats this sequence while stepping down the transmission speed to the last choice specified by selectors 4 through 6.

If the modem always falls back to a low transmission speed (e.g., 4,800 bps), set the first transmission speed choice to the lower one (e.g., modify it from 12,000 bps to 7,200 bps) in order to deactivate the high-speed modem function and reduce the training time for shorter transmission time.

Generally, to save the transmission time, set the last transmission speed choice to a higher one.

- **Selector 7: V. 34 mode**

This selector determines whether or not the equipment communicates with the remote station in the V. 34 mode when that station supports the V. 34 mode.

**WSW20 (Overseas communications mode setting)**

Selector No.	Function	Setting and Specifications
1	EP* tone prefix	0: OFF      1: ON
2	Overseas communications mode (Reception)	0: 2100 Hz      1: 1100 Hz
3	Overseas communications mode (Transmission)	0: OFF      1: Ignores DIS once.
4 5	Min. time length from reception of CFR to start of transmission of video signals	No. 4 5 0 0 : 100 ms 0 1 : 200 ms 1 0 : 300 ms 1 1 : 400 ms
6 7	Chattering noise elimination at detection of CNG	No. 6 7 0 0 : Yes (When CNG goes either ON or OFF) 0 1 : Yes (Only when CNG goes OFF) 1 0 : No 1 1 : No
8	CNG detection on/off	0: OFF      1: ON

\* EP: Echo protection

- **Selector 1: EP tone prefix**

Setting this selector to "1" makes the equipment transmit a 1700 Hz echo protection (EP) tone immediately preceding training in V.29 modulation system to prevent omission of training signals.

Prefixing an EP tone is effective when the equipment fails to transmit at the V.29 modem speed and always has to fall back to 4800 bps transmission.

- **Selectors 2 and 3: Overseas communications mode**

These selectors should be used if the facsimile equipment malfunctions in overseas communications. According to the communications error state, select the signal specifications.

Setting selector 2 to "1" allows the equipment to use 1100 Hz CED signal instead of 2100 Hz in receiving operation. This prevents malfunctions resulting from echoes, since the 1100 Hz signal does not disable the echo suppressor (ES) while the 2100 Hz signal does.

Setting selector 3 to "1" allows the equipment to ignore a DIS signal sent from the called station once in sending operation. This operation suppresses echoes since the first DIS signal immediately follows a 2100 Hz CED (which disables the ES) so that it is likely to be affected by echoes in the disabled ES state. However, such a disabled ES state will be removed soon so that the second and the following DIS signals are not susceptible to data distortion due to echoes. Note that some models when called may cause error by receiving a self-outputted DIS.

- **Selectors 8: CNG detection on/off**

If this selector is set to "1," the equipment detects a CNG signal according to the condition preset by selectors 2 and 3 of WSW18 after a line is connected. If it is set to "0," the equipment detects a CNG signal as long as the line is connected.

**WSW21 (TAD setting 1)**

Selector No.	Function	Setting and Specifications
1   7	Not used.	
8	Erasure of message stored in the memory after the message transfer	0: Yes      1: No

● **Selector 8: Erasure of message**

Setting this selector to "0" will erase the message recorded in the memory after the document retrieval feature transfers the message.

**WSW22 (ECM setting)**

Selector No.	Function	Setting and Specifications
1	ECM* in sending	0: ON      1: OFF
2	ECM* in receiving	0: ON      1: OFF
3	Call Waiting Caller ID	0: ON      1: OFF
4	Not used.	
5   8	Acceptable TCF bit error rate (%) (Only at 4800 bps)	0: 0%      1: 8% 0: 0%      1: 4% 0: 0%      1: 2% 0: 0%      1: 1%

\* ECM: Error correction mode

**NOTE:** Selector 3 is applicable to the American version only, but not applicable to those models equipped with high-speed modem.

**NOTE:** Selectors 5 through 8 are applicable to the Asian version only.

● **Selector 3: Call Waiting Caller ID**

Setting this selector to "0" allows the user to decide whether or not to interrupt the current call when a new call comes in. If Call Waiting Caller ID service is available in the area and the user subscribes to it, he/she can see information about his/her incoming call.

● **Selectors 5 through 8: Acceptable TCF bit error rate (%)**

Setting two or more selectors to "1" produces addition of percent assigned to each selector. If you set selectors 7 and 8 to "1," the acceptable TCF bit error rate will be 3%.



## WSW23 (Communications setting)

Selector No.	Function	Setting and Specifications
1	Starting point of training check (TCF)	0: From the head of a series of zeros 1: From any arbitrary point
2 3	Allowable training error rate	No. 2 3 0 0 : 0% 0 1 : 0.5% 1 0 : 1% 1 1 : 2%
4 5		Decoding error rate for transmission of RTN
6 7	Not used.	
8	Limitation of attenuation level	0: Yes      1: No

**NOTE:** Selector 8 is not applicable to the French versions.

- **Selector 1: Starting point of training check (TCF)**

At the training phase of receiving operation, the called station detects for 1.0 second a training check (TCF) command, a series of zeros which is sent from the calling station for 1.5 seconds to verify training and give the first indication of the acceptability of the line.

This selector sets the starting point from which the called station should start counting those zeros. If this selector is set to "0," the called station starts counting zeros 100 ms after the head of a series of zeros is detected.

If it is set to "1," the called station starts counting zeros upon detection of 10-ms successive zeros 50 ms after the head of a series of zeros is detected. In this case, if the detection of 10-ms successive zeros is too late, the data counting period will become less than 1.0 second, making the called station judge the line condition unacceptable.

- **Selectors 2 and 3: Allowable training error rate**

The called station checks a series of zeros gathered in training (as described in Selector 1) according to the allowable training error rate set by these selectors. If the called station judges the line condition to be accepted, it responds with CFR; if not, it responds with FTT.

- **Selectors 4 and 5: Decoding error rate for transmission of RTN**

The facsimile equipment checks the actual decoding errors and then transmits an RTN according to the decoding error rate (Number of lines containing an error per page ÷ Total number of lines per page) set by these selectors.

- **Selector 8: Limitation of attenuation level**

Setting this selector to "0" limits the transmitting level of the modem to 10 dB.

This setting has priority over the settings selected by WSW02 (selectors 5 through 8) and WSW13 (selectors 5 through 8).

WSW24 (TAD setting 2)

Selector No.	Function	Setting and Specifications
1 2	Not used.	
3 4	Time length from CML ON to start of pseudo ring backtone transmission	No. 3 4 0 0 : 4 sec. 0 1 : 3 sec. 1 0 : 2 sec. 1 1 : 1 sec.
5   8	Attenuator for playback of ICM/OGM to the line (Selectable from the range of 0-15 dB)	0: 0 dB      1: 8 dB 0: 0 dB      1: 4 dB 0: 0 dB      1: 2 dB 0: 0 dB      1: 1 dB

- **Selectors 3 and 4: Time length from CML ON to start of pseudo ring backtone transmission**

These selectors set the length of time from CML-ON up to the start of pseudo ring backtone transmission.

In those versions which have an OGM facility, the settings made by these selectors also apply to the length of time from CML-ON up to the start of OGM transmission.

- **Selectors 5 through 8: Attenuator for playback of ICM/OGM to the line**

Setting two or more selectors to "1" produces addition of attenuation assigned to each selector.

This setting will not be limited by selector 8 of WSW23.

## WSW25 (TAD setting 3)

Selector No.	Function	Setting and Specifications
1 2	Delay time for starting detection of voice signal	No. 1 2 0 0 : 0 sec. 0 1 : 8 sec. 1 0 : 16 sec. 1 1 : 24 sec.
3 4	Detection level for no voice signal	No. 3 4 0 0 : -43 dB (A) 0 1 : -46 dB (B) 1 0 : -49 dB (C) 1 1 : -51 dB (D)
5   7	Pause between paging number and PIN	No. 5 6 7 0 0 0 : 2 sec. 0 0 1 : 4 sec. 0 1 0 : 6 sec. 0 1 1 : 8 sec. 1 0 0 : 10 sec. 1 0 1 : 12 sec. 1 1 0 : 14 sec. 1 1 1 : 16 sec.
8	Not used.	

**NOTE:** Selectors 1 through 4 are not applicable to the U.S.A. versions.

**NOTE:** Selectors 5 through 7 are applicable to those models equipped with a built-in TAD.

- **Selectors 1 and 2: Delay time for starting detection of voice signal**

These selectors take effect only in TAD mode (when the external TAD is connected to the equipment). The equipment delays starting detection of the voice signal by the time length specified by these selectors.

The total length of the delay time specified by these selectors and the maximum waiting time specified by WSW21 (selectors 1 through 5) should not exceed 40 seconds.

- **Selectors 3 and 4: Detection level for no voice signal**

These selectors set the detection level for no voice signal in the TAD mode (when the external TAD is connected to the equipment).

- **Selectors 5 through 7: Pause between paging number and PIN**

These selectors set the pause time between a telephone number being paged and PIN (private identification number) for the paging feature.

## WSW26 (Function setting 4)

Selector No.	Function	Setting and Specifications
1 2	Not used.	
3	Dialing during document reading into the temporary memory in in-memory message transmission	0: Disabled      1: Enabled
4 5	No. of CNG cycles to be detected (when the line is connected via the external telephone except in the external TAD mode or via the built-in telephone of the facsimile equipment)	No. 4 5 0 0 : 0.5 (A) 0 1 : 1 (B) 1 0 : 1.5 (C) 1 1 : 2 (D)
6   8	Not used.	

- **Selector 3: Dialing during document reading into the temporary memory in in-memory message transmission**

If this selector is set to "0," the equipment waits for document reading into the memory to complete and then starts dialing. This enables the equipment to list the total number of pages in the header of the facsimile message.

- **Selectors 4 and 5: No. of CNG cycles to be detected**

The equipment interprets a CNG as an effective signal if it detects a CNG signal by the number of cycles specified by these selectors in any of the following cases:

- when the line is connected via the external telephone except in the external TAD mode.
- when the line is connected via the built-in telephone of the facsimile equipment.

## WSW27 (Function setting 5)

Selector No.	Function	Setting and Specifications
1	Definition of programmable key	0: TEL key    1: TEL/POLLING key
2	Ringer OFF setting	0: Yes        1: No
3	Not used.	
4	Detection of distinctive ringing pattern	0: Yes        1: No
5   7	Not used.	
8	Toner save mode	0: Yes        1: No

**NOTE:** Selector 1 takes effect only in models/versions having a TEL key.

**NOTE:** Selector 4 is applicable only to the U.S.A. version.

- **Selector 1: Definition of programmable key**

This selector defines a programmable key as a TEL key or TEL/POLLING key.

Setting this selector to "1" allows the programmable key to function as either a TEL or POLLING key if pressed when the handset is off or on the hook, respectively.

- **Selector 2: Ringer OFF setting**

This selector determines whether or not the ringer can be set to OFF.

- **Selector 4: Detection of distinctive ringing pattern**

If this selector is set to "1," the equipment detects only the number of rings; if it is set to "0," the equipment detects the number of rings and the ringing time length to compare the detected ringing pattern with the registered distinctive one.

WSW28 (Function setting 6)

Selector No.	Function	Setting and Specifications
1   3	Transmission level of DTMF high-band frequency signal	No. 1 2 3 0 0 0 : 0 dB 0 0 1 : +1 dB 0 1 0 : +2 dB 0 1 1 : +3 dB 1 0 0 : 0 dB 1 0 1 : -1 dB 1 1 0 : -2 dB 1 1 1 : -3 dB
4   6	Transmission level of DTMF low-band frequency signal	No. 4 5 6 0 0 0 : 0 dB 0 0 1 : +1 dB 0 1 0 : +2 dB 0 1 1 : +3 dB 1 0 0 : 0 dB 1 0 1 : -1 dB 1 1 0 : -2 dB 1 1 1 : -3 dB
7 8	Not used.	

• **Selectors 1 through 6: Transmission level of DTMF high-/low-band frequency signal**

These selectors are intended for the manufacturer who tests the equipment for the Standard. Never access them.

**WSW29 (Function setting 7)**

Selector No.	Function	Setting and Specifications
1   6	Not used.	
7	Impedance switching control in pulse dialing	0: OFF      1: ON
8	Beep when the memory area for the activity report becomes full	0: No      1: Yes

**NOTE:** Selectors 7 and 8 are applicable to the European version only.

- **Selector 8: Beep when the memory area for the activity report becomes full**

If this selector is set to "1," the equipment will beep when the memory area for the activity report becomes full (as well as displaying a message on the LCD, prompting the output of the activity report).

**WSW30 (Function setting 8)**

Selector No.	Function	Setting and Specifications
1   3	Not used.	
4	Duty cycle control of pulsed current for the heat-fixing unit	0: OFF      1: ON
5	Drum cleaning prompt settings	0: OFF      1: ON
6   8	Not used.	

**NOTE:** Selector 4 is applicable to the European version only.

- **Selector 4: Duty cycle control of pulsed current for the heat-fixing unit**

Setting this selector to "1" activates the duty cycle control that suppresses the rush current. The duty cycle is 10-ms ON and 20-ms OFF.

However, the duty cycle control may emit switching noise to the AC line. Depending upon the codes and regulations in the country, this selector should be set to "0."

- **Selector 5: Drum cleaning prompt settings**

Setting this selector to "1" (OFF) deactivates all of the drum cleaning prompt settings enabled by selectors 5 to 7 of WSW42.

## WSW31 (Function setting 9)

Selector No.	Function	Setting and Specifications
1	Not used.	
2	Default reduction rate for failure of automatic reduction during recording	0: 100%    1: Reduction rate specified according to the current paper size
3 4	Not used.	
5	Minimum short-OFF duration in distinctive ringing	0: 130 ms    1: 90 ms
6 7	Not used.	
8	"CHANGE DRUM SOON" message	0: Yes    1: No

- **Selector 2: Default reduction rate for failure of automatic reduction during recording**

This selector sets the default reduction rate to be applied if the automatic reduction function fails to record one-page data sent from the calling station in a single page of the current recording paper.

If it is set to "0," the equipment records one-page data at full size (100%) without reduction; if it is set to "1," the equipment records it at the size\* specified according to the current paper size.

(\*American versions allow the user to select the desired paper size from the control panel. According to the paper size setting, the equipment determines the reduction rate. Other versions can handle only A4-size paper, so the reduction rate is always 87%.)

- **Selector 5: Minimum short-OFF duration in distinctive ringing**

The ringer pattern consists of short and long rings, e.g., short-short-long rings. This selector sets the minimum OFF duration following a short ring in order to avoid missing ringer tones in distinctive ringing.

If this selector is set to "1," when the short-OFF duration is a minimum of 90 ms long, then the equipment will interpret the short-OFF as OFF.

- **Selector 8: "CHANGE DRUM SOON" message**

This selector determines whether or not the "CHANGE DRUM SOON" message should appear on the LCD when the service life of the laser-sensitive drum in the laser unit will expire soon.



**WSW32 (Function setting 10)**

Selector No.	Function	Setting and Specifications
1   4	Not used.	
5 6	Default resolution	No. 5 6 0 0 : Standard 0 1 : Fine 1 0 : Super fine 1 1 : Photo
7 8	Default contrast	No. 7 8 0 X : Automatic 1 0 : Super light 1 1 : Super dark

- **Selectors 5 and 6: Default resolution**

These selectors set the default resolution which applies when the equipment is powered up or completes a transaction.

- **Selectors 7 and 8: Default contrast**

These selectors set the default contrast which applies when the equipment is powered up or completes a transaction.

**WSW33 (Function setting 11)**

Selector No.	Function	Setting and Specifications
1   5	Not used.	
6	Report output of polled transmission requests	0: Yes      1: No
7 8	Not used.	

**NOTE:** Selector 6 is not applicable to American versions.

## WSW34 (Function setting 12)

Selector No.	Function	Setting and Specifications
1   3	Not used.	
4  5	No. of CNG cycles to be detected (when the line is connected via the facsimile equipment in the F/T mode or via the external telephone in the external TAD mode)	No. 4 5 0 0 : 0.5 (A) 0 1 : 1 (B) 1 0 : 1.5 (C) 1 1 : 2 (D)
6  7	Number of DTMF tone signals for inhibiting the detection of CNG during external TAD operation	No. 6 7 0 0 : 3 0 1 : 2 1 0 : 1 1 1 : OFF
8	CNG detection when the external telephone is connected with a line in TAD mode	0: Only when the equipment detects itself being called 1: Always

**NOTE:** Selectors 4 and 5 are not applicable to the American version.

- **Selectors 4 and 5: No. of CNG cycles to be detected**

The equipment interprets a CNG as an effective signal if it detects a CNG signal by the number of cycles specified by these selectors when the line is connected via the facsimile equipment in the F/T mode or via the external telephone in the external TAD mode.

- **Selectors 6 and 7: Number of DTMF tone signals for inhibiting the detection of CNG during external TAD operation**

If the equipment receives this specified number of DTMF tone signals during external TAD operation, then it will not detect CNG afterwards.

If these selectors are set to "1, 1," the CNG detection will not be inhibited.

- **Selector 8: CNG detection when the external telephone is connected with a line in TAD mode**

If this selector is set to "0," the equipment will detect a CNG signal only when it detects itself being called. If the external telephone is connected with a line before the equipment detects itself being called, the equipment will no longer detect a CNG signal.

If this selector is set to "1," the equipment will detect a CNG signal every time the external telephone is connected with a line, even without detecting itself being called.

## WSW35 (Function setting 13)

Selector No.	Function	Setting and Specifications
1   8	Not used.	

## WSW36 (Function setting 14)

Selector No.	Function	Setting and Specifications
1	ECP* mode	0: ON      1: OFF
2	Recovery from inactive PC interface	0: Disabled    1: Enabled
3	PC power-off recognition time	0: Normal    1: Long
4	Not used.	
5	Escape from phase C	0: Yes      1: No
6   8	Lower limit of frequency to be ignored after detection of calling signals (Ci)	No. 6 7 8 0 0 0 : 0 (Not ignored) 0 0 1 : 4 (448 Hz) 0 1 0 : 8 (244 Hz) 0 1 1 : 12 (162 Hz) 1 0 0 : 16 (122 Hz) 1 0 1 : 20 (97 Hz) 1 1 0 : 24 (81 Hz) 1 1 1 : 28 (69 Hz)

\*ECP (Enhanced Capabilities Port)

- **Selector 1: ECP mode**

The ECP mode enhances the normal bidirectional communications between the facsimile equipment and the connected PC for higher transmission speed.

- **Selector 2: Recovery from inactive PC interface**

If the facsimile equipment recognizes via the STB signal line that the connected PC is powered off, then it will turn the PC interface output Low to protect the PC from hazards that could be caused by weak electric current accidentally flown from the equipment.

This selector determines whether the equipment should recover from the inactive PC interface to normal interfacing state upon receipt of data from the PC.

- **Selector 3: PC power-off recognition time**

This selector sets the time length from when the equipment detects the PC powered off until it recognizes the detected state as power-off.

If selector 2 is set to "0," it is recommended that selector 3 be set to "1": otherwise, the equipment may mistakenly detect PC powered off.

- **Selector 5: Escape from phase C**

This selector determines whether or not the equipment will escape from phase C when it detects an RTC (Return to Control) in non-ECM mode or an RCP (Return to Control Partial page) in ECM mode.

- **Selectors 6 through 8: Lower limit of frequency to be ignored after detection of calling signals (Ci)**

At the start of reception, if the equipment detects the frequency of calling signals (Ci) specified by selectors 1 through 4 of WSW14, it will start the ringer sounding. When doing so, the equipment may fail to detect the calling signals normally due to noises superimposed at the time of reception. To prevent it, use selectors 6 through 8 of WSW36.

If the equipment detects higher frequencies than the lower limit specified by these selectors, then it will regard them as noise and interpret that detecting state as being normal, allowing the ringer to keep sounding (until the equipment starts automatic reception of FAX data if in the FAX mode or enters the TAD mode if set in the TEL mode, according to the preset number of ringers).

## WSW37 (Function setting 15)

Selector No.	Function	Setting and Specifications
1	Printout of the stored image data of an unsent document onto the error report	0: No      1: Yes
2	Erasure of the stored image data of an unsent document at the time of the subsequent in-memory message transmission	0: No      1: Yes
3   8	Not used.	

- **Selector 1: Printout of the stored image data of an unsent document onto an error report**

This selector determines whether or not the 1st-page image data of a document will be printed out onto the error report if the document image data stored in the temporary memory cannot be transmitted normally.

- **Selector 2: Erasure of the stored image data of an unsent document at the time of the subsequent in-memory message transmission**

If in-memory message transmission fails repeatedly when selector 1 is set to "1," the temporary memory will be occupied with image data. Setting selector 2 to "1" will automatically erase the stored 1st-page image data of an unsent document at the time of the subsequent in-memory message transmission only when recording paper or toner runs out.

## WSW38 (Function setting 16, in V. 34 mode)

Selector No.	Function	Setting and Specifications
1 2	Setting of the equalizer	No. 1 2 0 X : Automatic 1 0 : Fixed to 4 points 1 1 : Fixed to 16 points
3	Sending level of guard tone at phase 2	0: Normal - 7 db 1: Normal
4	Stepping down the transmission speed at fallback each	0: 2400 bps 1: 4800 bps
5 6	Automatic control of modem's EQM gain for proper transmission speed choice	No. 5 6 0 0 : For higher transmission speed than the current setting 0 1 : No change from the current setting 1 0 : For lower transmission speed than the current setting 1 1 : For further lower transmission than the setting made by 1, 0
7	Redialing when a communications error occurs	0: ON 1: OFF
8	Not used.	

**NOTE:** WSW38 takes effect only in V. 34 mode.

- **Selectors 1 and 2: Setting of the equalizer**

These selectors set the equalizer's training level to be applied if the facsimile equipment fails to send training due to weak line connection. If these selectors are set to "0, X," the modem will automatically set the appropriate training level.

- **Selector 3: Sending level of guard tone at phase 2**

This selector sets the sending level of guard tone for 1800 Hz to be sent at Phase 2 in the V. 34 mode.

- **Selector 4: Stepping down the transmission speed at fallback each**

This selector determines how much the modem steps down the transmission speed at fallback when called by the remote station. If this selector is set to "1," the modem may step down the transmission speed from 33600 bps to 28800 bps by one-time fallback.

- **Selectors 5 and 6: Automatic control of modem's EQM gain for proper transmission speed choice**

These selectors determine how the modem controls the EQM (Eye Quality Monitor) gain for proper choice of the transmission speed, which applies if the modem selects higher transmission speed than the possible speed so that it always repeats falling back.

**WSW39 (Transmission speed setting in V. 34 mode)**

Selector No.	Function	Setting and Specifications
1   4	First transmission speed choice for fallback	No. 1 2 3 4 No. 5 6 7 8 0 0 0 0 : 2400 bps 0 0 0 1 : 4800 bps 0 0 1 0 : 7200 bps 0 0 1 1 : 9600 bps 0 1 0 0 : 12000 bps 0 1 0 1 : 14400 bps 0 1 1 0 : 16800 bps 0 1 1 1 : 19200 bps 1 0 0 0 : 21600 bps 1 0 0 1 : 24000 bps 1 0 1 0 : 26400 bps 1 0 1 1 : 28800 bps 1 1 0 0 : 31200 bps 1 1 0 1 : 33600 bps 1 1 1 0 : 33600 bps 1 1 1 1 : 33600 bps
5   8	Last transmission speed choice for fallback	

**NOTE:** WSW39 takes effect only in V. 34 mode. For the transmission speed setting in other modes, refer to WSW19.

• **Selectors 1 through 8: First and last choices of transmission speed for fallback**

These selectors are used to set the modem speed range. With the first transmission speed choice specified by selectors 1 through 4, the equipment attempts to establish the transmission link via the modem. If the establishment fails, the equipment automatically steps down to the next highest speed and attempts to establish the transmission link again. The equipment repeats this sequence while stepping down the transmission speed to the last choice specified by selectors 5 through 8.

If the modem always falls back to a low transmission speed (e.g., 24,000 bps), set the first transmission speed choice to the lower one (e.g., modify it from 31,200 bps to 26,400 bps) in order to deactivate the high-speed modem function and reduce the training time for shorter transmission time.

WSW39 will be limited by selectors 3 through 8 of WSW40.

WSW40 (Function setting 17, in V. 34 mode)

Selector No.	Function	Setting and Specifications																												
1	Not used.																													
2	Automatic paper cassette choice in copying	0: Disabled      1: Enabled (Fixed to upper paper cassette)																												
3   8	Masking of symbol rate(s)	<table border="0"> <thead> <tr> <th></th> <th>Not masking</th> <th>Masking</th> <th></th> </tr> </thead> <tbody> <tr> <td>No. 3</td> <td>0</td> <td>1</td> <td>3429 symbols/sec</td> </tr> <tr> <td>No. 4</td> <td>0</td> <td>1</td> <td>3200 symbols/sec</td> </tr> <tr> <td>No. 5</td> <td>0</td> <td>1</td> <td>3000 symbols/sec</td> </tr> <tr> <td>No. 6</td> <td>0</td> <td>1</td> <td>2800 symbols/sec</td> </tr> <tr> <td>No. 7</td> <td>-</td> <td>-</td> <td>Not used.</td> </tr> <tr> <td>No. 8</td> <td>0</td> <td>1</td> <td>2400 symbols/sec</td> </tr> </tbody> </table>		Not masking	Masking		No. 3	0	1	3429 symbols/sec	No. 4	0	1	3200 symbols/sec	No. 5	0	1	3000 symbols/sec	No. 6	0	1	2800 symbols/sec	No. 7	-	-	Not used.	No. 8	0	1	2400 symbols/sec
	Not masking	Masking																												
No. 3	0	1	3429 symbols/sec																											
No. 4	0	1	3200 symbols/sec																											
No. 5	0	1	3000 symbols/sec																											
No. 6	0	1	2800 symbols/sec																											
No. 7	-	-	Not used.																											
No. 8	0	1	2400 symbols/sec																											

**NOTE:** WSW40 takes effect only in V. 34 mode.

**NOTE:** Selector 2 is applicable only to models equipped with a flat-bed scanner.

• **Selector 2: Automatic paper cassette choice in copying**

If an optional lower cassette is loaded and you have set either of the upper and lower cassettes as being loaded with longer paper from the control panel, then the facsimile equipment may automatically select either of those cassettes in copying depending upon the document length scanned by the ADF.

• **Selectors 3 and 8: Masking of symbol rate(s)**

These selectors allow you to limit the transmission speed range in V. 34 mode by masking the desired symbol rate(s). Transmission speeds assigned to the symbol rates are listed on the next page. The setting made by these selectors will limit the setting made by selectors 1 through 4 of WSW39.

If selector 3 is set to "1" to mask the 3429 symbols/second when the first transmission speed choice is 33600 bps (specified by selectors 1 through 4 of WSW39), for example, then the allowable maximum transmission speed will be limited to 31200 bps. If selector 8 is set to "1" to mask the 2400 symbols/second when the first transmission speed choice is 33600 bps, then the allowable maximum transmission speed remains 33600 bps.

If selector 8 is set to "1" to mask the 2400 symbols/second when the first transmission speed choice is 21600 bps (specified by selectors 1 through 4 of WSW39), then the allowable maximum transmission speed remains 21600 bps but the minimum transmission speed will be limited to 4800 bps.

Symbol rate	Transmission speed (bps)	Symbol rate	Transmission speed (bps)	Symbol rate	Transmission speed (bps)
2400	2400	3000	4800	3429	4800
	4800		7200		7200
	7200		9600		9600
	9600		12000		12000
	12000		14400		14400
	14400		16800		16800
	16800		19200		19200
	19200		21600		21600
	21600		24000		24000
	21600		26400		28800
2800	4800	3200	4800		33600
	7200		7200		
	9600		9600		
	12000		12000		
	14400		14400		
	16800		16800		
	19200		19200		
	21600		21600		
	24000		24000		
	26400		26400		
			28800		
			31200		



**WSW41 (CCD fluorescent lamp and modem attenuator, in V. 34 mode)**

Selector No.	Function	Setting and Specifications
1   3	ON-duration of the fluorescent lamp built in the CCD unit	No. 1 2 3 0 0 0 : 16 hours 0 0 1 : 24 hours 0 1 0 : 12 hours 0 1 1 : 8 hours 1 0 0 : 4 hours 1 0 1 : 2 hours 1 1 0 : 10 minutes 1 1 1 : 0 minute
4	Not used.	
5   8	Modem attenuator	No. 5 6 7 8 0 0 0 0 : -10 dBm 0 0 0 1 : -11 dBm 0 0 1 0 : -12 dBm 0 0 1 1 : -13 dBm 0 1 0 0 : -14 dBm     1 1 1 1 : -25 dBm

**NOTE:** WSW41 takes effect only in V. 34 mode.

**NOTE:** Selectors 1 through 3 are applicable only to models equipped with a flat-bed scanner.

- **Selectors 1 through 3: ON-duration of the fluorescent lamp built in the CCD unit**

If the scanning operation is started when the fluorescent lamp is off, then the lamp will come on and stay on for the time length specified by these selectors.

If these selectors are set to "1, 1, 1," the fluorescent lamp will go off after the scanning sequence.

- **Selectors 5 through 8: Modem attenuator**

These selectors are used to adjust the transmitting level of the modem when the reception level at the remote station is improper due to line loss. This function applies to super G3 protocol signals.

## WSW42 (Function setting 18)

Selector No.	Function	Setting and Specifications	
1	Incoming mail server POP* <sup>1</sup>	0: OFF	1: ON
2	Incoming mail server SMTP* <sup>2</sup>	0: OFF	1: ON
3	Internet-FAX forward function	0: OFF	1: ON
4	JBIG* <sup>3</sup> coding system	0: Disabled	1: Enabled
5	Alarm message when the corona wire abnormally emits ions	0: Enabled	1: Disabled
6	Issue of a drum cleaning prompting sheet when the corona wire abnormally emits ions	0: Enabled	1: Disabled
7	Issue of a drum cleaning prompting sheet when the specified number of pages has been printed	0: Enabled	1: Disabled
8	Not used.		

\*<sup>1</sup> POP: Post Office Protocol\*<sup>2</sup> SMTP: Simple Mail Transfer Protocol\*<sup>3</sup> JBIG: Joint Bi-level Image Group

**NOTE:** Selectors 1 through 3 are applicable to those models equipped with LAN interface.

- **Selector 3: Internet-FAX forward function**

If this selector is set to "ON," the machine may forward a FAX message received through Internet to other remote G3 facsimile equipment.

- **Selector 5: Alarm message when the corona wire abnormally emits ions**

This selector determines whether or not the alarm message "PLS CLEAN DRUM" will appear on the LCD when the corona wire abnormally emits ions.

- **Selector 6: Issue of drum cleaning prompting sheet when the corona wire abnormally emits ions**

This selector determines whether or not a drum cleaning prompting sheet will be printed out when the corona wire abnormally emits ions. The sheet prompts the user to clean the corona wire of the laser-sensitive drum.

- **Selector 7: Issue of a drum cleaning prompting sheet when the specified number of pages has been printed**

This selector determines whether or not a drum cleaning prompting sheet will be printed out when the specified number of pages has been printed (that is, when it is assumed that the corona wire becomes dirty). The sheet prompts the user to clean the corona wire of the laser-sensitive drum.

**WSW43 (Function setting 19)**

Selector No.	Function	Setting and Specifications
1	Not used.	
2 3	Wait time for PCFax reception (Class 2) and FPTS command transmission	No. 2 3 0 0 : 50 ms 0 1 : 100 ms 1 0 : 150 ms 1 1 : 0 ms
4 5	Detection time of 2100 Hz CED or ANSam	No. 4 5 0 0 : 200 ms 0 1 : 300 ms 1 0 : 400 ms 1 1 : 500 ms
6   8	Not used.	

**WSW44 (Speeding up scanning-1)**

Selector No.	Function	Setting and Specifications
1   5	Not used.	
6   8	Effective time length of the white level compensation data obtained beforehand	No. 6 7 8 0 0 0 : Obtained compensation data ineffective 0 0 1 : 1 min. 0 1 0 : 3 min. 0 1 1 : 5 min. 1 0 0 : 10 min. 1 0 1 : 15 min. 1 1 0 : 20 min. 1 1 1 : 30 min.

**NOTE:** WSW44 is applicable only to models equipped with a flat-bed scanner.

- **Selectors 6 through 8: Effective time length of the white level compensation data obtained beforehand**

If you set documents in the ADF and the document front sensor detects them or if you open the document tray ASSY and the document tray open sensor detects the open state, then the controller will make correction of the reference voltage to be applied to white level compensation for document scanning before the Copy button is pressed.

These selectors determine how long compensation data obtained beforehand will keep effective.

## WSW45 (Speeding up scanning-2)

Selector No.	Function	Setting and Specifications
1   3	Delay time from when documents are set until the ADF starts drawing them in	No. 1 2 3 0 0 0 : No automatic drawing-in 0 0 1 : 1 sec. 0 1 0 : 2 sec. 0 1 1 : 3 sec. 1 0 0 : 4 sec. 1 0 1 : 5 sec. 1 1 0 : 6 sec. 1 1 1 : 7 sec.
4   6	Periodical correction intervals of the reference voltage to be applied to white level compensation for document scanning, during standby	No. 4 5 6 0 0 0 : No correction of reference voltage during standby 0 0 1 : 10 sec. 0 1 0 : 30 sec. 0 1 1 : 1 min. 1 0 0 : 3 min. 1 0 1 : 5 min. 1 1 0 : 10 min. 1 1 1 : 30 min.
7	Home position of the CCD unit	0: CCD lock position    1: Location of the white-level reference film
8	Not used.	

**NOTE:** WSW45 is applicable only to models equipped with a flat-bed scanner.

- **Selectors 1 through 3: Delay time from when documents are set until the ADF starts drawing them in**

These selectors determine how long the ADF will delay automatic drawing-in of documents (to the scanning standby position) after you set them in the ADF, as well as determining whether or not the ADF automatically draws in documents.

- **Selectors 4 through 6: Periodical correction intervals of the reference voltage applied to white level compensation for document scanning, during standby**

These selectors set the correction intervals (in seconds) of the reference voltage to be applied to white level compensation for document scanning during standby, as well as determining whether or not the controller makes the reference voltage correction during standby. (Conventionally, the correction has been made immediately before the start of actual scanning)

This function takes effect in copying. Making the correction during standby may shorten the preparation time for copying.

**NOTE:** Do not access these selectors.

- **Selector 7: Home position of the CCD unit**

This selector determines whether the home position of the CCD unit should be the CCD lock position or the location of the white-level reference film (attached to the inside of the scanner top cover). If the location of the reference film is selected, the CCD unit will not return to the lock position so as to shorten the travel time, decreasing the preparation time for copying.

**WSW46 (Monitor of power ON/OFF state and parallel port kept at high)**

Selector No.	Function	Setting and Specifications
1 2	Monitoring the PC ON/OFF state	No. 1 2 0 0 : Disabled 0 1 : Monitor SELECT IN 1 0 : Monitor STROBE 1 1 : Monitor both SELECT IN and STROBE
3	Parallel port output pins kept at high level	
4   8	Not used.	

**NOTE:** Selector 3 is applicable only to models equipped with a parallel interface.

- **Selectors 1 and 2: Monitoring the PC ON/OFF state**

For the related functions, refer to WSW36, selectors 2 and 3.

- **Selector 3: Parallel port output pins kept at high level**

Setting this selector to "0" will keep all parallel output pins of the facsimile equipment at high level. Use this setting if Resource Manager (bundled with MFC models) installed to WindowsNT running on the connected PC fails to monitor the power ON/OFF state of the facsimile equipment.

**WSW47 (Delay of FAX line disconnection)**

Selector No.	Function	Setting and Specifications
1 2	Not used.	
3 4	Delay of FAX line disconnection when switching to the pseudo-ringing external telephone	No. 3 4 0 0 : 200 ms 0 1 : 400 ms 1 0 : 700 ms 1 1 : 1000 ms
5   8	Not used.	

**NOTE:** Selectors 3 and 4 are applicable only to models supporting pseudo-ringing of a connected external telephone.

- **Selectors 3 and 4: Delay of FAX line disconnection when switching to the pseudo-ringing external telephone**

When the equipment receives a phone call, it can make the connected external telephone ring (so called pseudo-ringing). During pseudo-ringing, if you pick up the handset of the external telephone, the line might be disconnected due to cut-off of the line current.

To hold the line, the equipment may supply line current by making use of the pulse generator circuit that forms a parallel loop. This way the FAX line disconnection may be delayed. These selectors determine the delay period.

**WSW48 to WSW50**

Selector No.	Function	Setting and Specifications
1   8	Not used.	

# MFC8500/FAX4100/FAX4750e/FAX5750e MFC9660/FAX8360P

## Appendix 3. Circuit Diagrams

- A. Main PCB (V. 17) (MFC8500)  
Main PCB (V. 34) (FAX4100/FAX4750e/FAX5750e/MFC9660/FAX8360P)
- B. Engine PCB
- C. Network Control Unit (NCU) PCB
- D. Control Panel PCB
- E. Power Supply PCBs

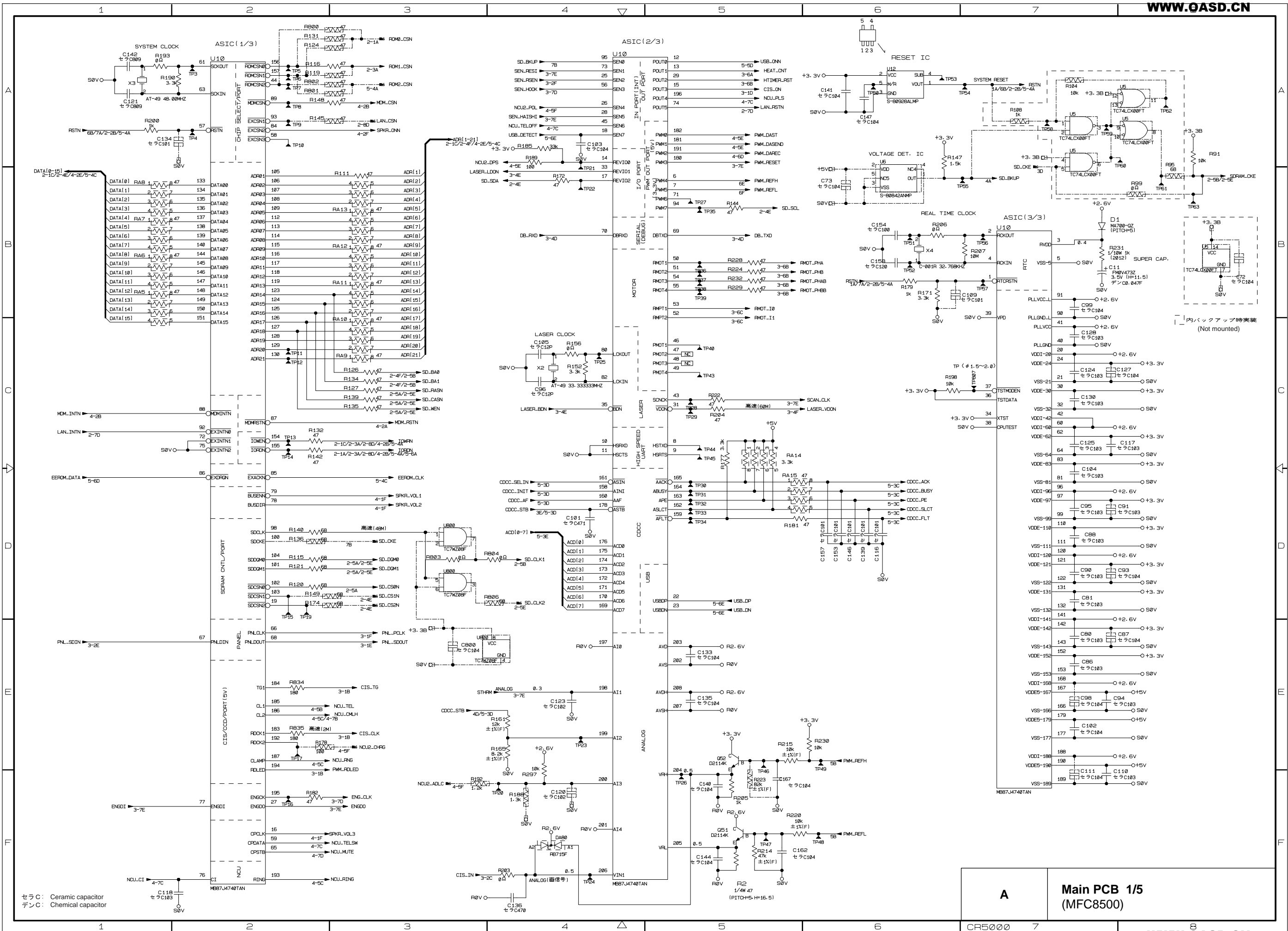

セラ C: Ceramic capacitor  
 デン C: Chemical capacitor

**A**

**Main PCB 1/5  
(MFC8500)**

CR5000



US PIN FUNCTION

PIN No.	16M	16M	32M	32M
1	WE		NC	NC
2	A18		A18	A18
43	A19		A19	A19
44	NC		NC	A20

UB PIN FUNCTION

PIN No.	AMD(FUJITSU)			INTEL(SHARP)		
	4M	16M	32M	4M	16M	32M
16	NC	A18	A18	NC	A18	A18
9	NC	NC	A19	NC	NC	(A19)
10	NC	NC	NC	NC	NC	A20
13	NC	NC	NC	VPP	VPP	VPP
14	NC	NC	NC	WP/APP	WP	WP
15	NC	NC	NC	NC	A19	A19

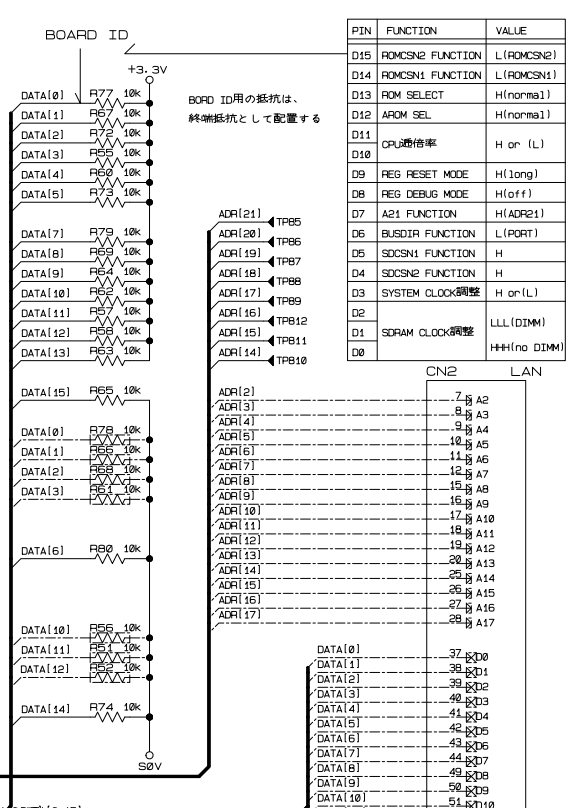
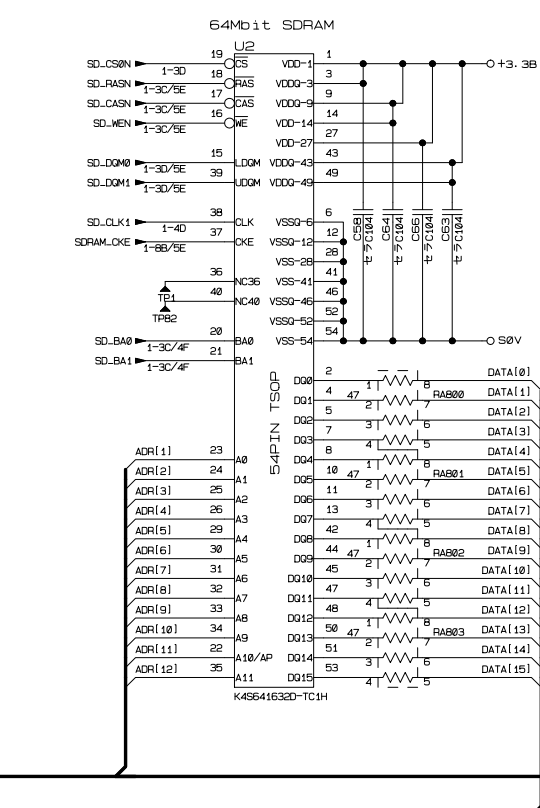
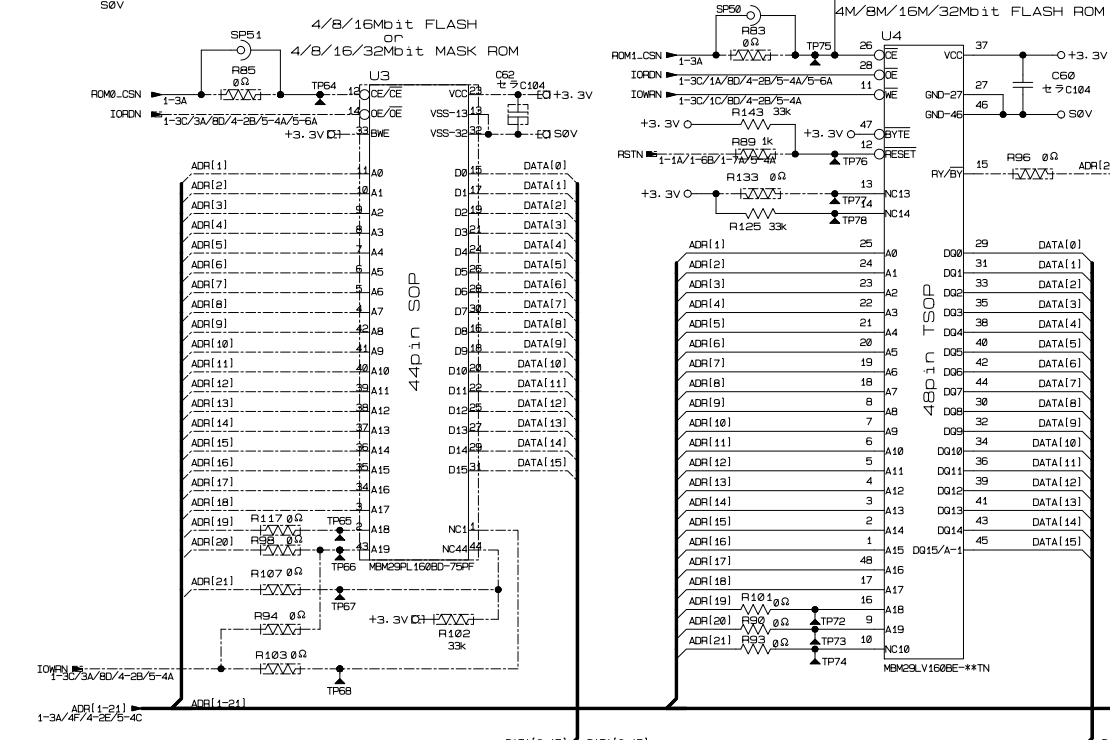

PIN	FUNCTION	VALUE
D15	ROMCSN2 FUNCTION	L(RMCSN2)
D14	ROMCSN1 FUNCTION	L(RMCSN1)
D13	ROM SELECT	H(norma1)
D12	APOM SEL	H(norma1)
D11	CPU選格率	H or (L)
D10	REG RESET MODE	H(long)
D9	REG DEBUG MODE	H(off)
D7	A21 FUNCTION	H(ADR21)
D6	BUSDIR FUNCTION	L(PORT)
D5	SOC5N1 FUNCTION	H
D4	SOC5N2 FUNCTION	H
D3	SYSTEM CLOCK調整	H or(L)
D2	SRAM CLOCK調整	LLL (DIMM)
D1	SRAM CLOCK調整	HHH(no DIMM)
D0		

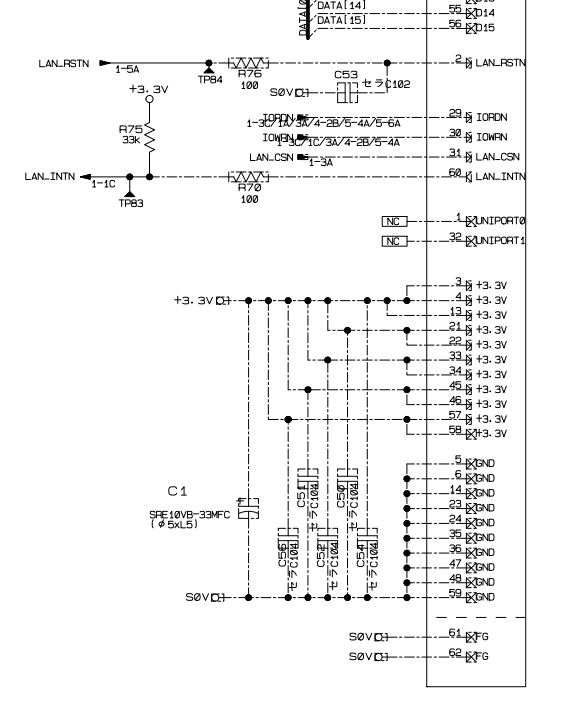
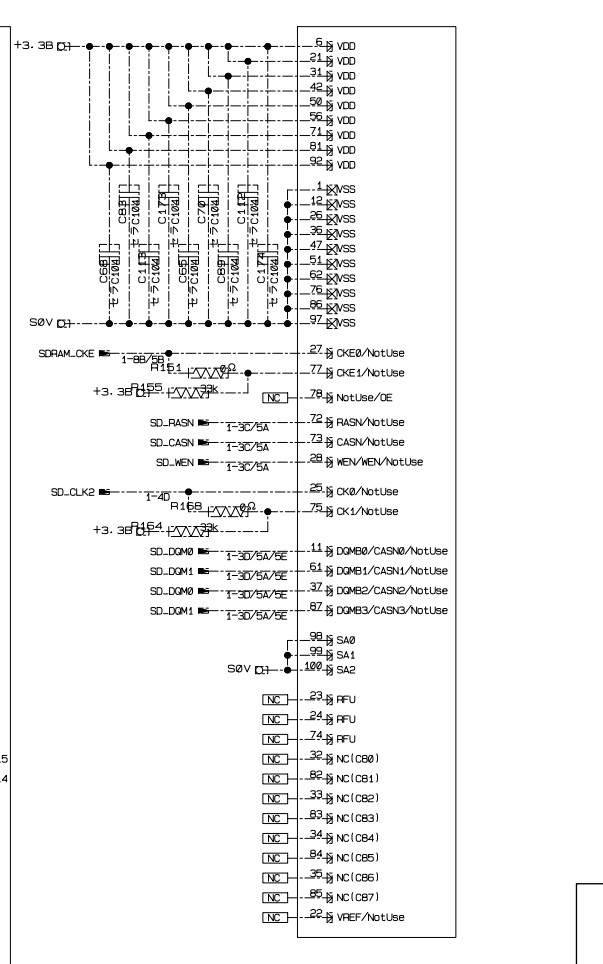
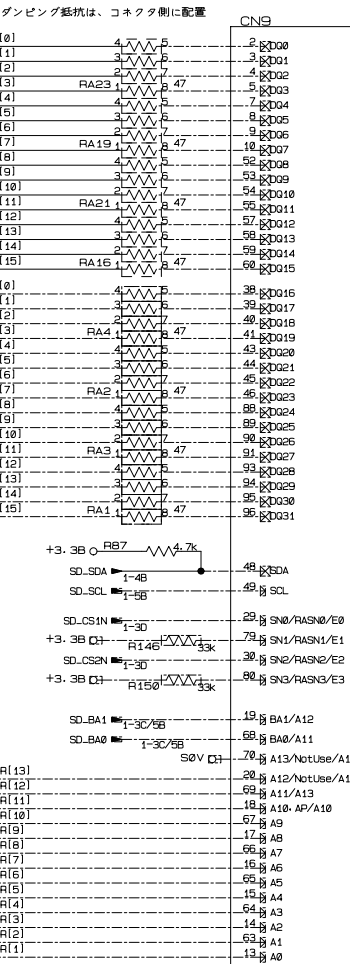
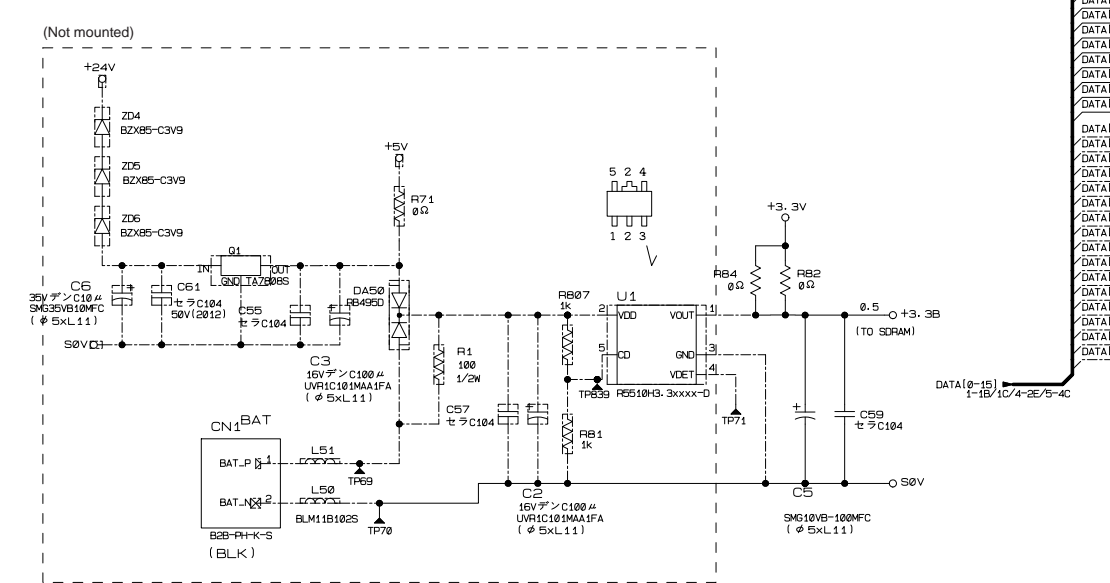

セラC: Ceramic capacitor  
デンC: Chemical capacitor

A Main PCB 2/5 (MFC8500)

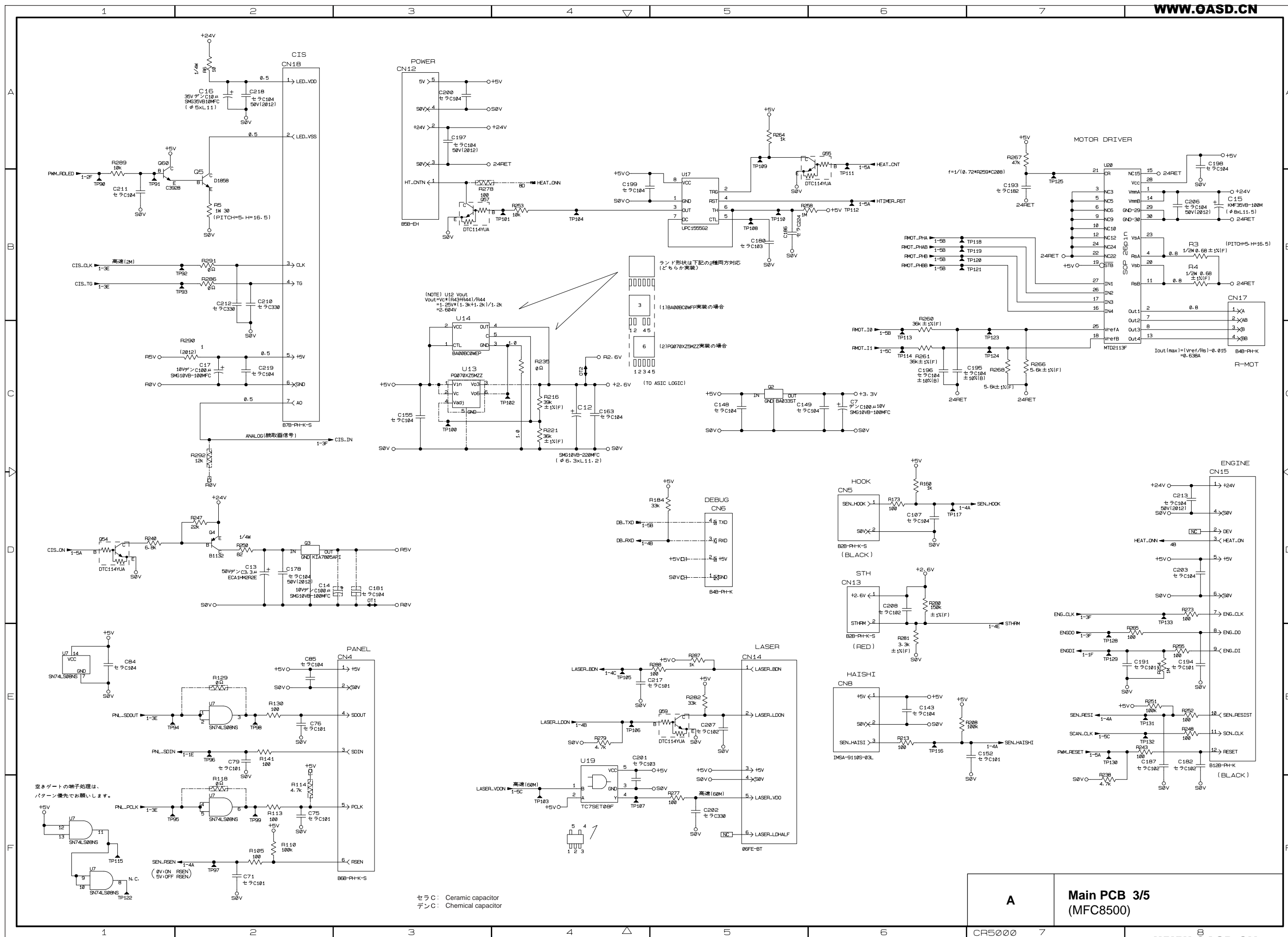

セラC : Ceramic capacitor  
 デンC : Chemical capacitor

**A** Main PCB 3/5 (MFC8500)

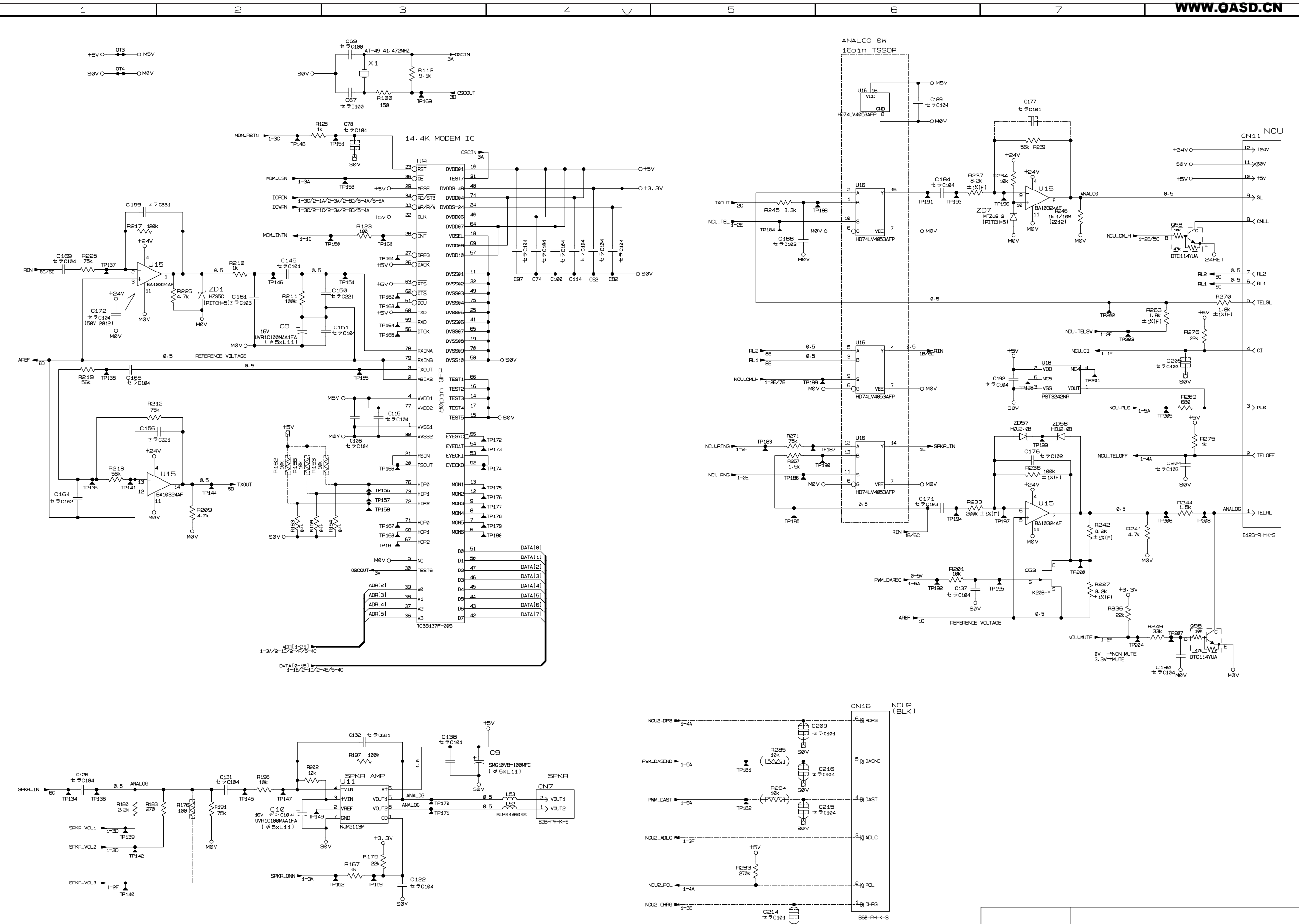

セラC: Ceramic capacitor  
 デンC: Chemical capacitor

**A** Main PCB 4/5 (MFC8500)

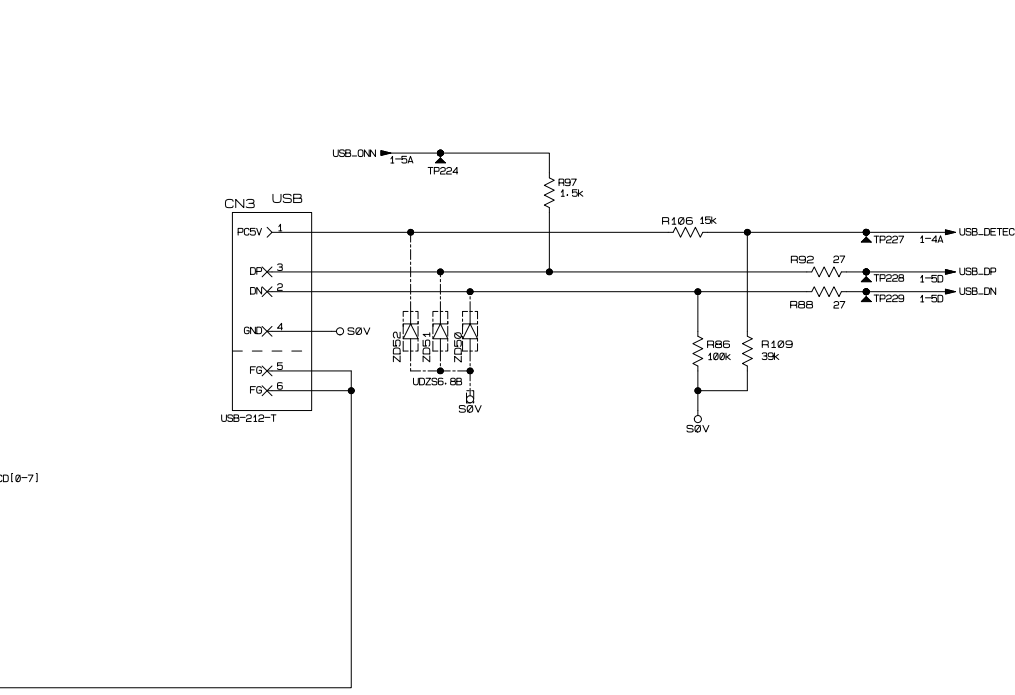
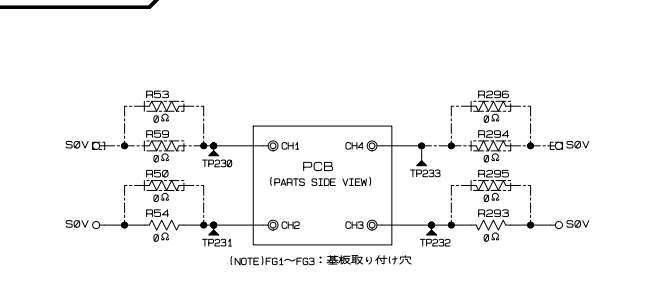
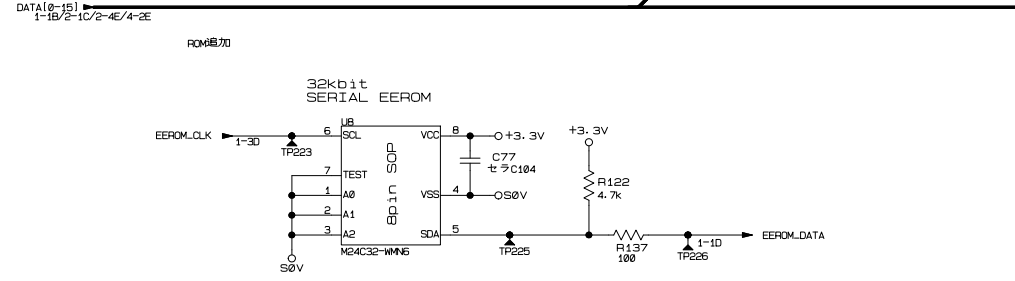
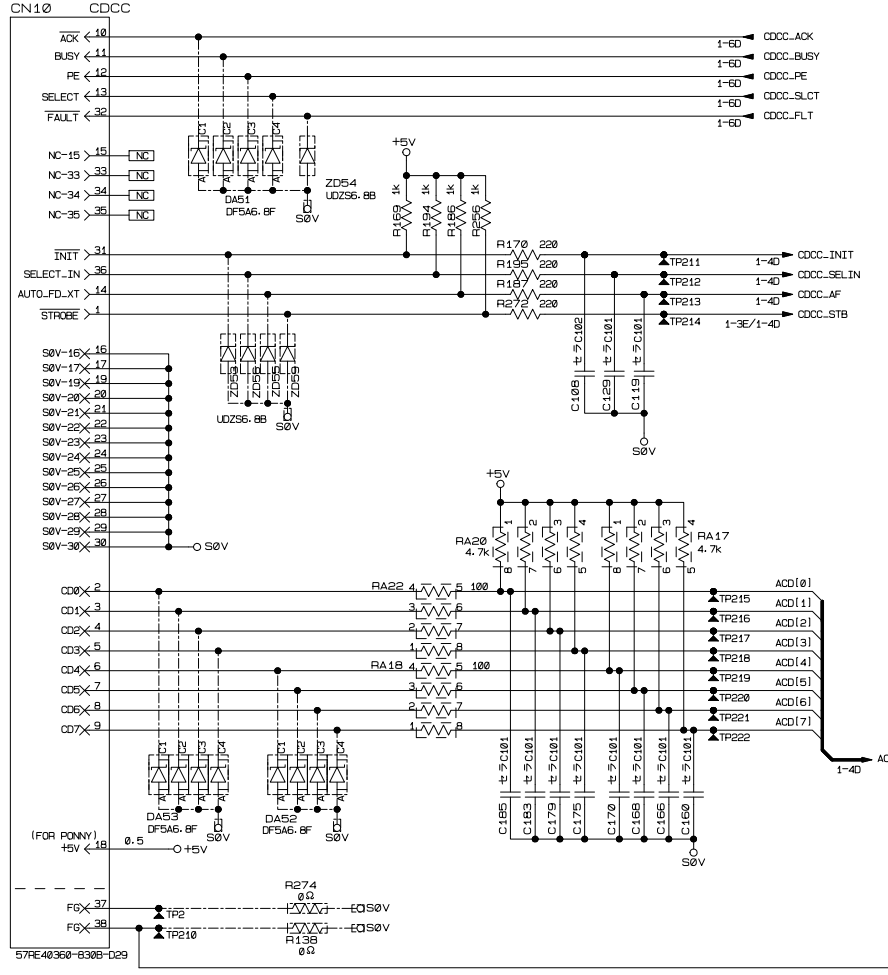
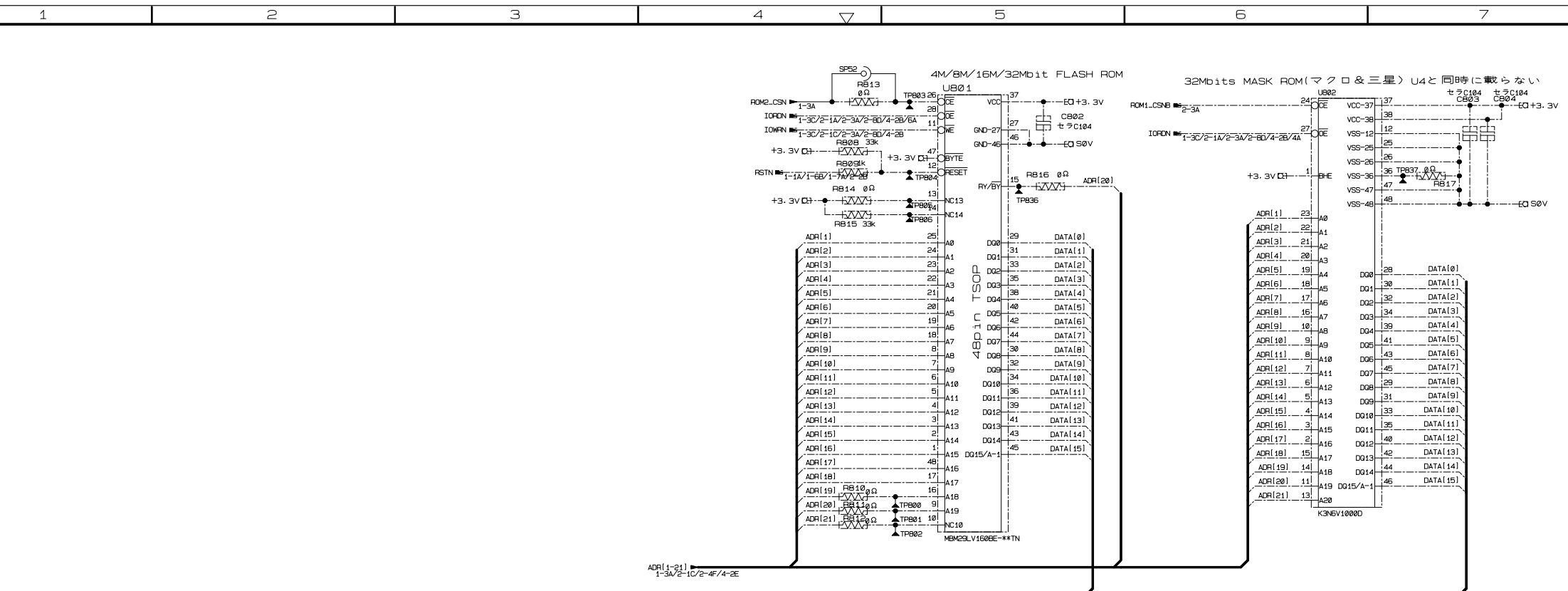

セラC : Ceramic capacitor



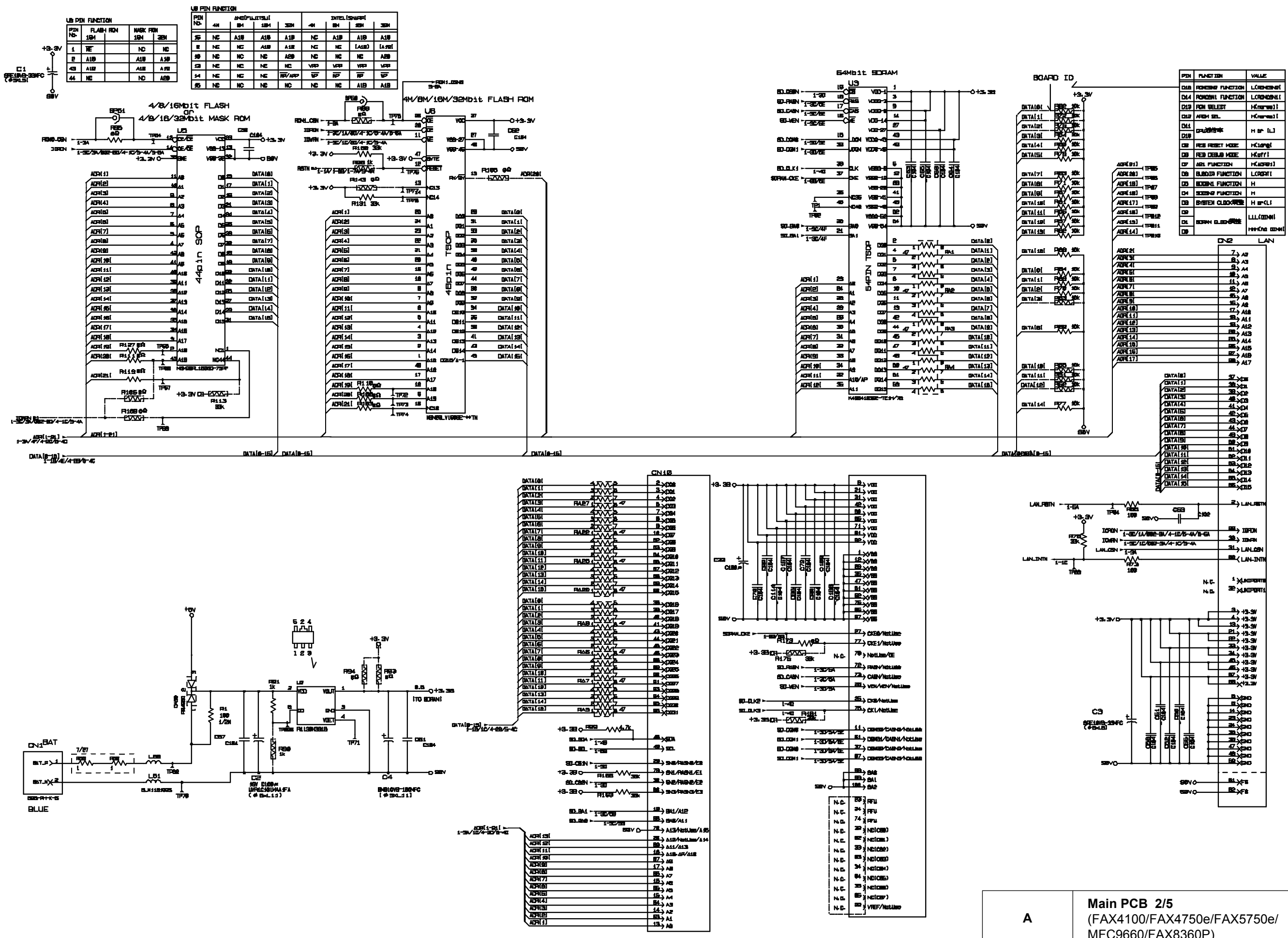

IPIN	FUNCTION	VALUE
DN3	ROMSEL FUNCTION	LCRDEN[0]
DN4	ROMSEL FUNCTION	LCRDEN[1]
DN3	ROM SELECT	H[0]
DN4	ROM SEL	H[0]
DN4	DATA[0]	H or L[0]
DN	RES RESET MODE	H[0]
DN	RES DESEL MODE	H[0]
DN	RES FUNCTION	H[0]
DN	BLUDD FUNCTION	LCRDEN[1]
DN	ROMSEL FUNCTION	H
DN	ROMSEL FUNCTION	H
DN	SYSTEM CLOCK/RES	H or L[1]
DN	SYSTEM CLOCK/RES	LLL/000H
DN	SYSTEM CLOCK/RES	H or L[0]

DATA[0]	DATA[1]	DATA[2]	DATA[3]	DATA[4]	DATA[5]	DATA[6]	DATA[7]	DATA[8]	DATA[9]	DATA[10]	DATA[11]	DATA[12]	DATA[13]	DATA[14]	DATA[15]
DATA[0]	DATA[1]	DATA[2]	DATA[3]	DATA[4]	DATA[5]	DATA[6]	DATA[7]	DATA[8]	DATA[9]	DATA[10]	DATA[11]	DATA[12]	DATA[13]	DATA[14]	DATA[15]
DATA[16]	DATA[17]	DATA[18]	DATA[19]	DATA[20]	DATA[21]	DATA[22]	DATA[23]	DATA[24]	DATA[25]	DATA[26]	DATA[27]	DATA[28]	DATA[29]	DATA[30]	DATA[31]
DATA[32]	DATA[33]	DATA[34]	DATA[35]	DATA[36]	DATA[37]	DATA[38]	DATA[39]	DATA[40]	DATA[41]	DATA[42]	DATA[43]	DATA[44]	DATA[45]	DATA[46]	DATA[47]
DATA[48]	DATA[49]	DATA[50]	DATA[51]	DATA[52]	DATA[53]	DATA[54]	DATA[55]	DATA[56]	DATA[57]	DATA[58]	DATA[59]	DATA[60]	DATA[61]	DATA[62]	DATA[63]
DATA[64]	DATA[65]	DATA[66]	DATA[67]	DATA[68]	DATA[69]	DATA[70]	DATA[71]	DATA[72]	DATA[73]	DATA[74]	DATA[75]	DATA[76]	DATA[77]	DATA[78]	DATA[79]
DATA[80]	DATA[81]	DATA[82]	DATA[83]	DATA[84]	DATA[85]	DATA[86]	DATA[87]	DATA[88]	DATA[89]	DATA[90]	DATA[91]	DATA[92]	DATA[93]	DATA[94]	DATA[95]
DATA[96]	DATA[97]	DATA[98]	DATA[99]	DATA[100]	DATA[101]	DATA[102]	DATA[103]	DATA[104]	DATA[105]	DATA[106]	DATA[107]	DATA[108]	DATA[109]	DATA[110]	DATA[111]
DATA[112]	DATA[113]	DATA[114]	DATA[115]	DATA[116]	DATA[117]	DATA[118]	DATA[119]	DATA[120]	DATA[121]	DATA[122]	DATA[123]	DATA[124]	DATA[125]	DATA[126]	DATA[127]
DATA[128]	DATA[129]	DATA[130]	DATA[131]	DATA[132]	DATA[133]	DATA[134]	DATA[135]	DATA[136]	DATA[137]	DATA[138]	DATA[139]	DATA[140]	DATA[141]	DATA[142]	DATA[143]
DATA[144]	DATA[145]	DATA[146]	DATA[147]	DATA[148]	DATA[149]	DATA[150]	DATA[151]	DATA[152]	DATA[153]	DATA[154]	DATA[155]	DATA[156]	DATA[157]	DATA[158]	DATA[159]
DATA[160]	DATA[161]	DATA[162]	DATA[163]	DATA[164]	DATA[165]	DATA[166]	DATA[167]	DATA[168]	DATA[169]	DATA[170]	DATA[171]	DATA[172]	DATA[173]	DATA[174]	DATA[175]
DATA[176]	DATA[177]	DATA[178]	DATA[179]	DATA[180]	DATA[181]	DATA[182]	DATA[183]	DATA[184]	DATA[185]	DATA[186]	DATA[187]	DATA[188]	DATA[189]	DATA[190]	DATA[191]
DATA[192]	DATA[193]	DATA[194]	DATA[195]	DATA[196]	DATA[197]	DATA[198]	DATA[199]	DATA[200]	DATA[201]	DATA[202]	DATA[203]	DATA[204]	DATA[205]	DATA[206]	DATA[207]
DATA[208]	DATA[209]	DATA[210]	DATA[211]	DATA[212]	DATA[213]	DATA[214]	DATA[215]	DATA[216]	DATA[217]	DATA[218]	DATA[219]	DATA[220]	DATA[221]	DATA[222]	DATA[223]
DATA[224]	DATA[225]	DATA[226]	DATA[227]	DATA[228]	DATA[229]	DATA[230]	DATA[231]	DATA[232]	DATA[233]	DATA[234]	DATA[235]	DATA[236]	DATA[237]	DATA[238]	DATA[239]
DATA[240]	DATA[241]	DATA[242]	DATA[243]	DATA[244]	DATA[245]	DATA[246]	DATA[247]	DATA[248]	DATA[249]	DATA[250]	DATA[251]	DATA[252]	DATA[253]	DATA[254]	DATA[255]

A  
Main PCB 2/5  
(FAX4100/FAX4750e/FAX5750e/  
MFC9660/FAX8360P)



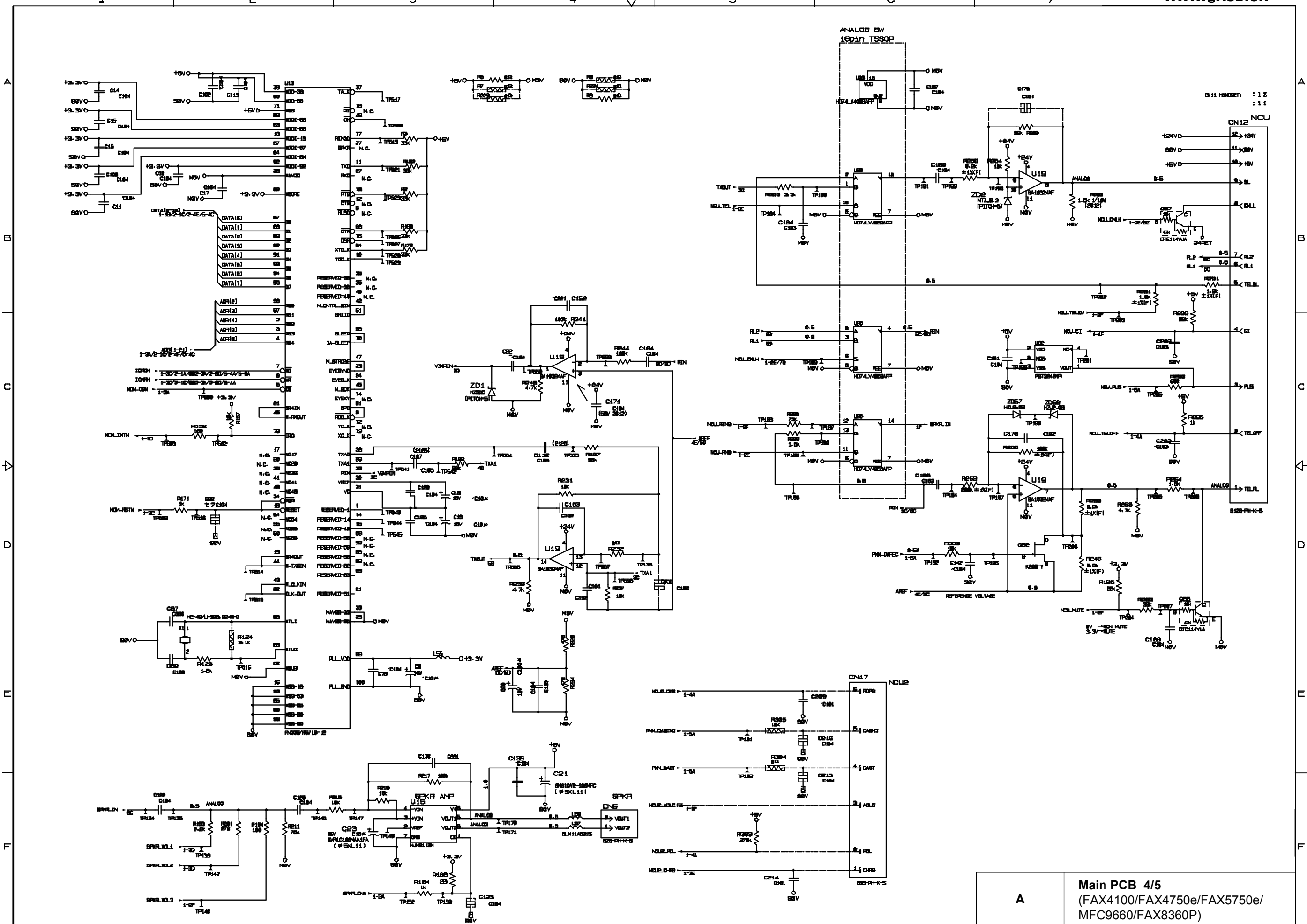

A

Main PCB 4/5  
 (FAX4100/FAX4750e/FAX5750e/  
 MFC9660/FAX8360P)





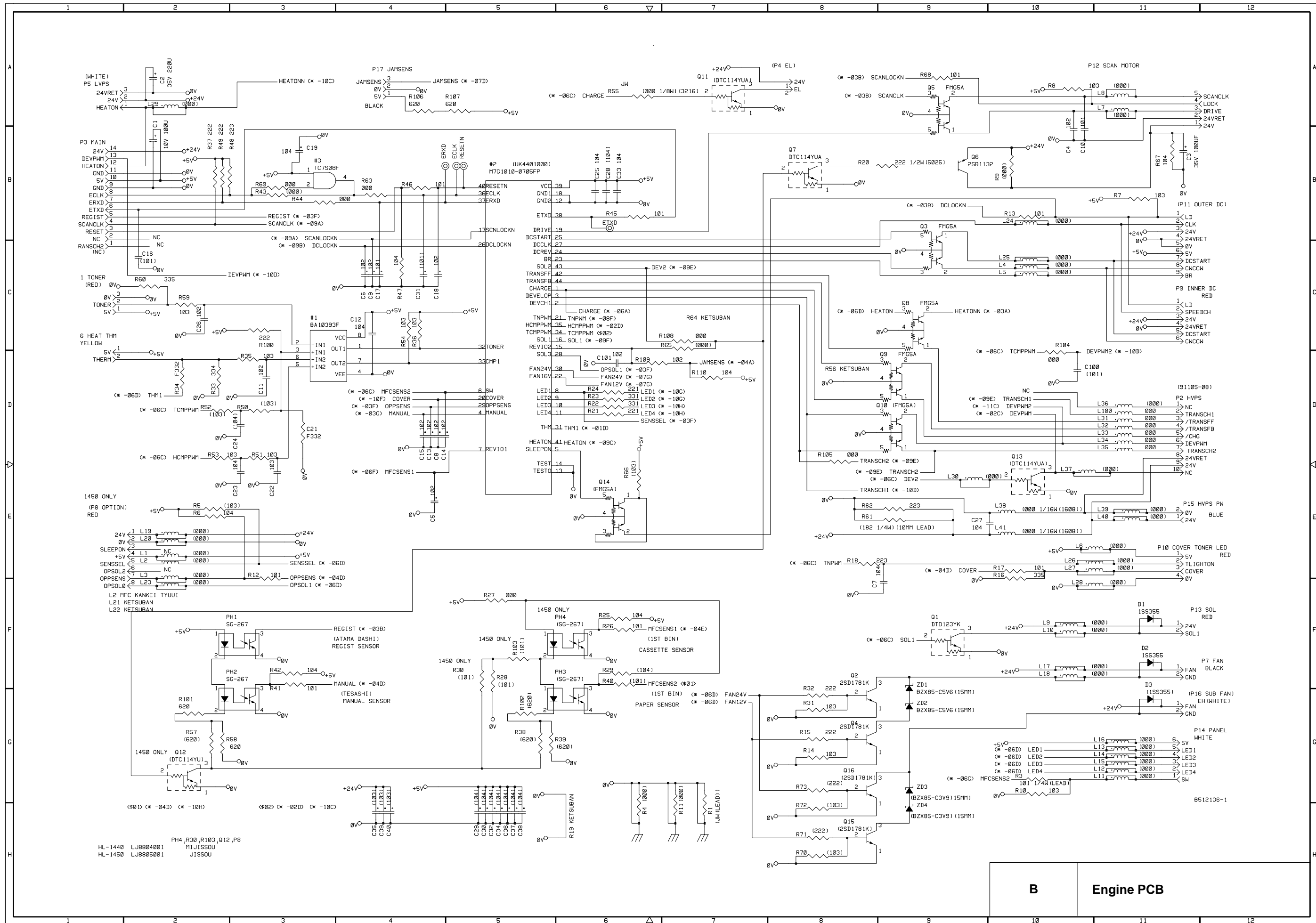

HL-1440 LJ8804001 PH4, R30, R103, Q12, P8  
 HL-1450 LJ8805001 MIJISSOU JISSOU

<b>B</b>	<b>Engine PCB</b>
----------	-------------------

1. 指示ナキ抵抗ノ消費電力ハ1/4Wトスル。
1. UNLESS OTHERWISE SPECIFIED, POWER CONSUMPTION OF RESISTORS IS 1/4W.
2. 指示ナキコンデンサノ耐圧ハ25V又ハ50Vトスル。
2. UNLESS OTHERWISE SPECIFIED, THE VOLTAGE RESISTANCE OF CAPACITORS IS 25V OR 50V.
3. ( ) 内ノ部品ハ未実装トスル。
3. COMPONENTS IN PARENTHESIS NOT TO BE MOUNTED.

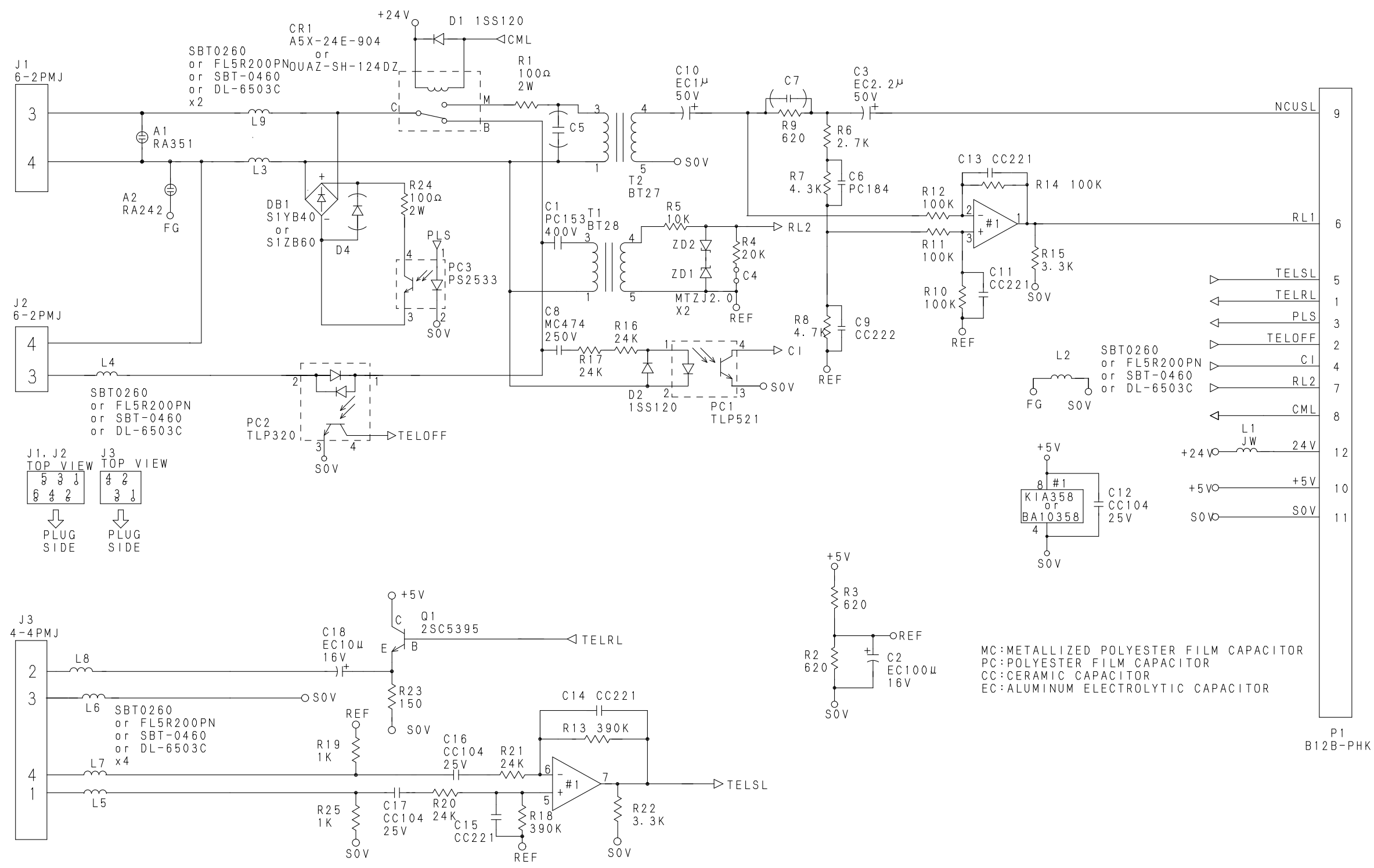

**C**      **NCU PCB (V.17)**  
(U.S.A./Canada)

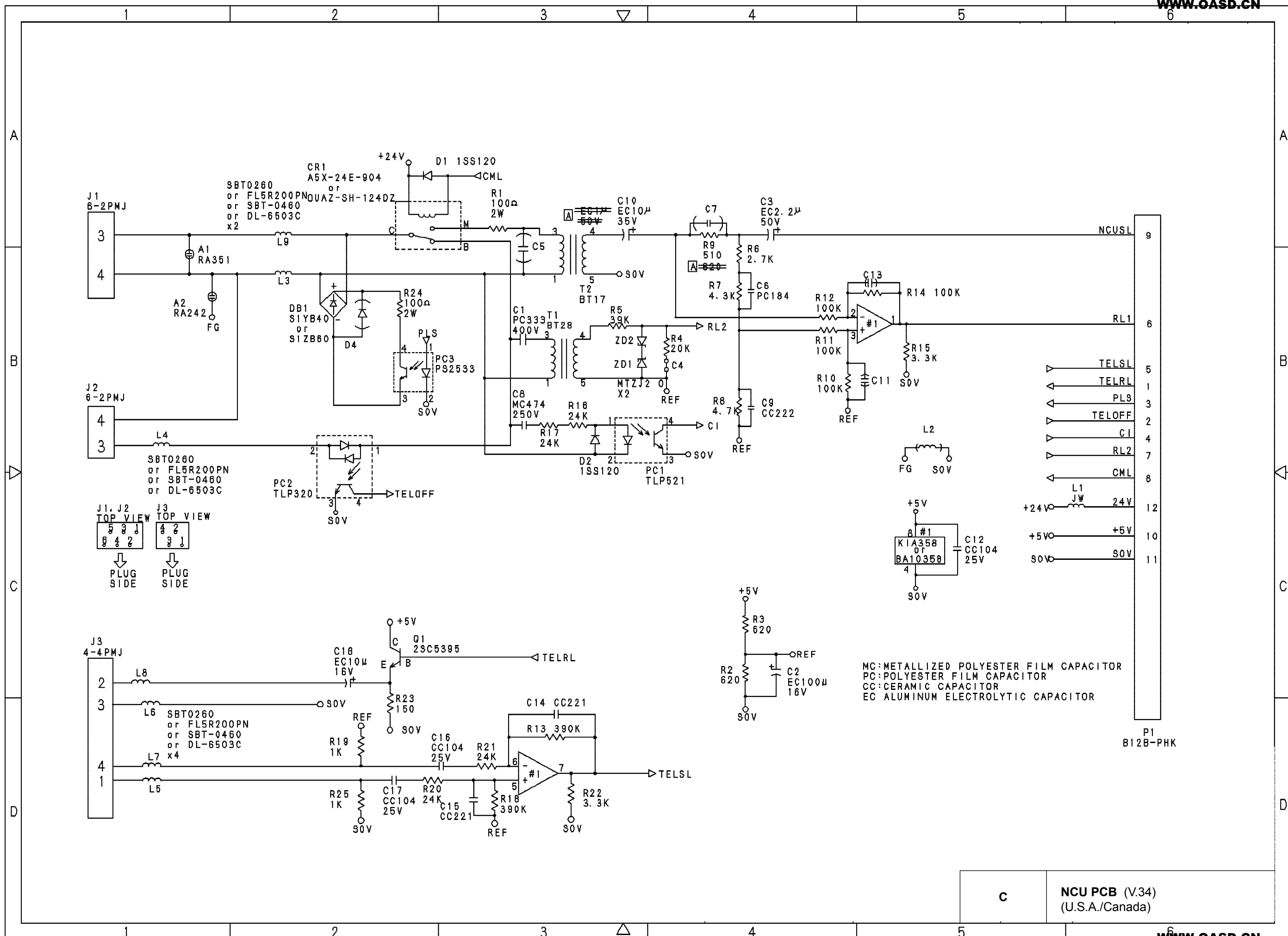

**C**      **NCU PCB (V.34)**  
 (U.S.A./Canada)

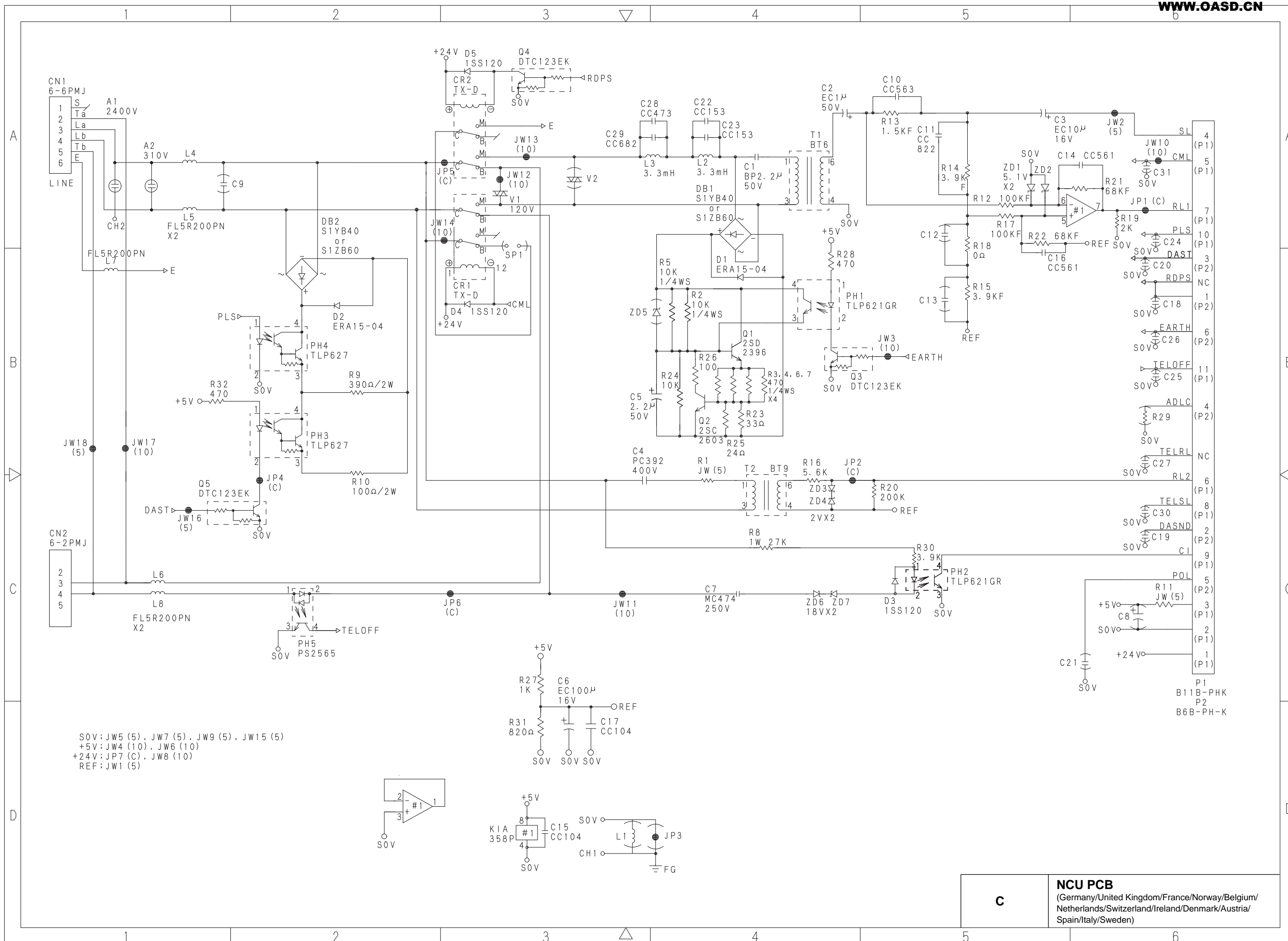

**C** **NCU PCB**  
 (Germany/United Kingdom/France/Norway/Belgium/  
 Netherlands/Switzerland/Ireland/Denmark/Austria/  
 Spain/Italy/Sweden)

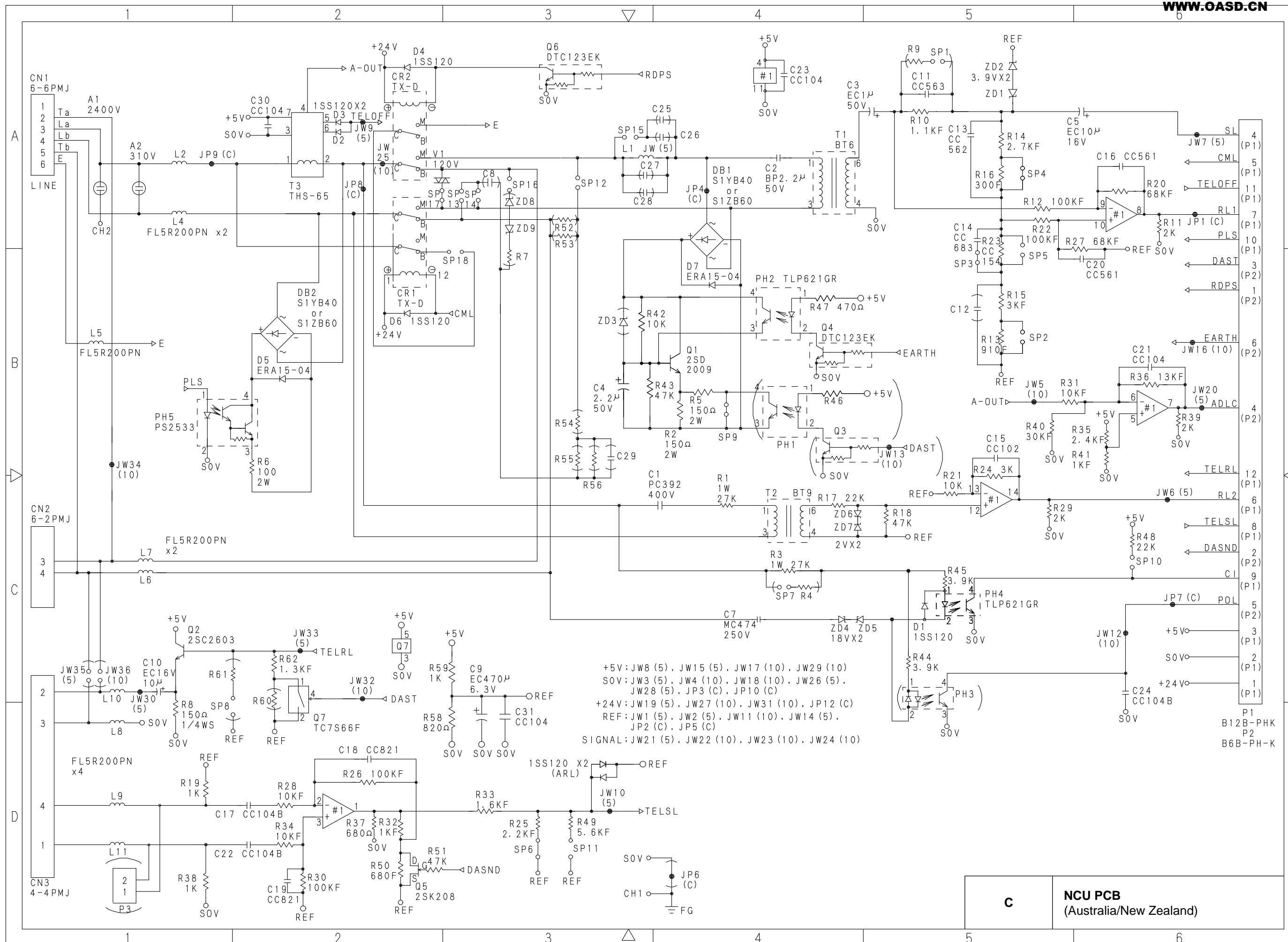

+5V: JW8 (5), JW15 (5), JW17 (10), JW29 (10)  
 SOV: JW3 (5), JW4 (10), JW18 (10), JW26 (5), JW28 (5), JP3 (C), JP10 (C)  
 +24V: JW19 (5), JW27 (10), JW31 (10), JP12 (C)  
 REF: JW1 (5), JW2 (5), JW11 (10), JW14 (5), JP2 (C), JP5 (C)  
 SIGNAL: JW21 (5), JW22 (10), JW23 (10), JW24 (10)

**C** NCU PCB (Australia/New Zealand)

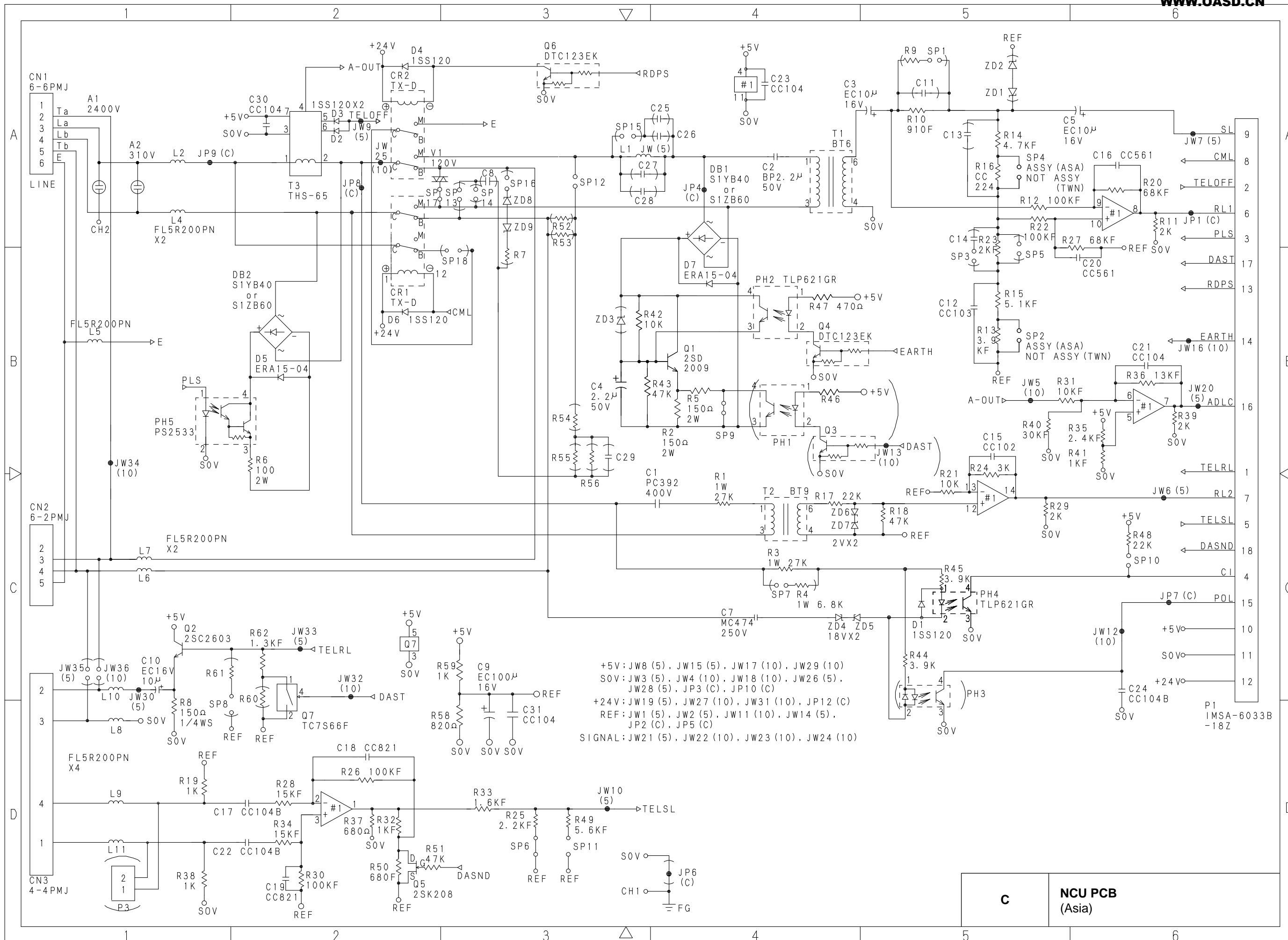

**C** NCU PCB (Asia)

1. ( ) 内ノ部品ハ未実装トスル。  
1. COMPONENTS IN PARENTHESIS NOT TO BE MOUNTED.

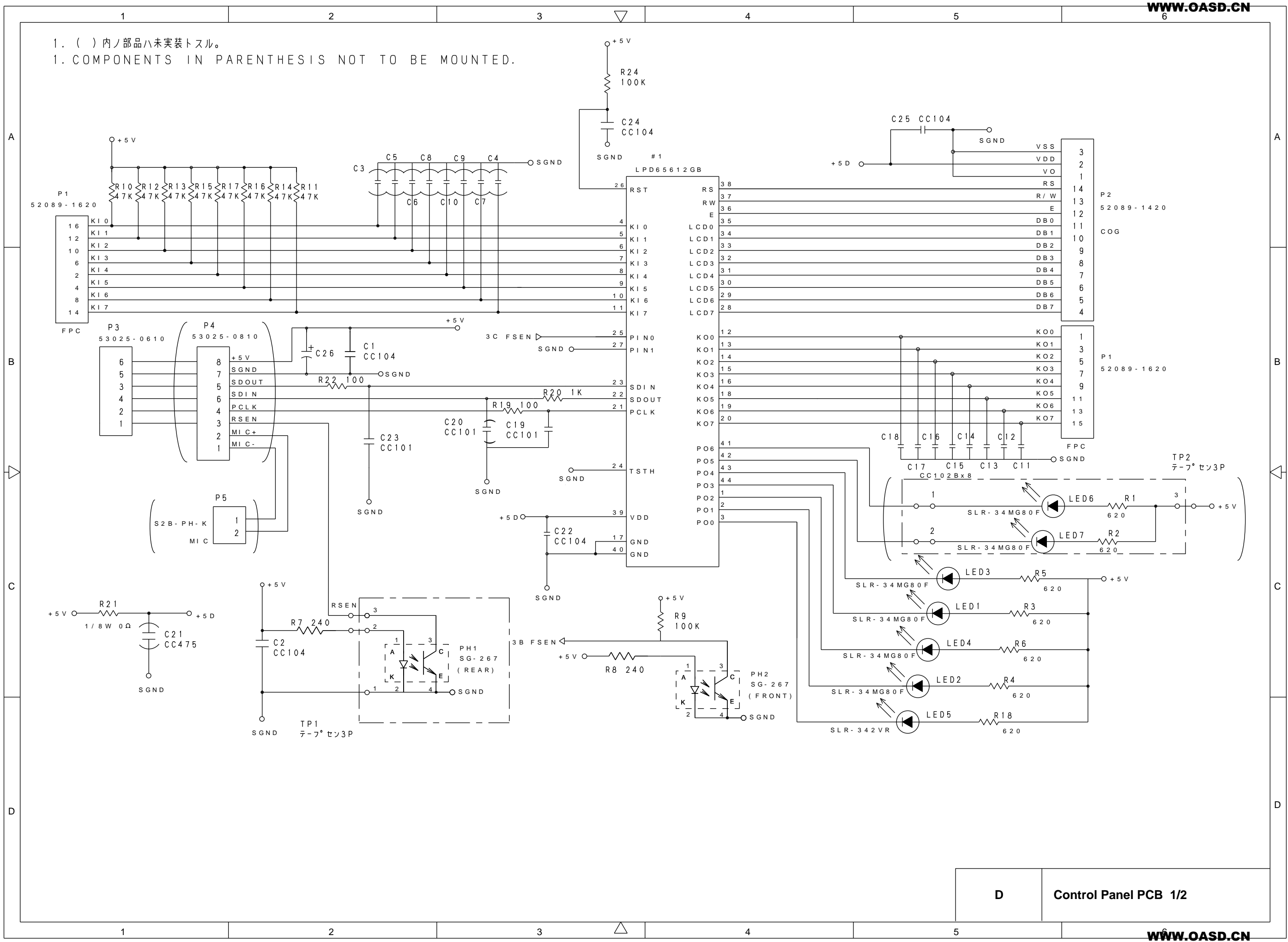

D Control Panel PCB 1/2



ZL PANEL KEY MATRIX REFERENCE TABLE 1

KEY NO.	KEY NAME	KEY CODE
1 / 63		25
2 / 62		2D
3 / 64		2E
4		2C
5	1TOUCH-01/17	0D
6	1TOUCH-02/18	05
7	1TOUCH-03/19	26
8	1TOUCH-04/20	24
9	1TOUCH-05/21	35
10	1TOUCH-06/22	0E
11	1TOUCH-07/23	06
12	1TOUCH-08/24	04
13	1TOUCH-09/25	15
14	1TOUCH-10/26	36
15	1TOUCH-11/27	16
16	1TOUCH-12/28	34
17		0C
18	1TOUCH-13/29	1D
19	1TOUCH-14/30	1E
20	1TOUCH-15/31	1C
21	1TOUCH-16/32	14
22	Shift	3C
23	Function	2F
24	←	27
25	SET	22
26	→	23
27	Clear	2B
28	Hook	07
29	10KEY-1	37
30	10KEY-2	2A
31	10KEY-3	33
32	Hold	0F
33	10KEY-4	02
34	10KEY-5	32
35	10KEY-6	03
36	Redial/Pause	17

KEY NO.	KEY NAME	KEY CODE
37	10KEY-7	0A
38	10KEY-8	12
39	10KEY-9	13
40	Volume High	0B
41	Speed Dial	1F
42	10KEY-*	1A
43	10KEY-0	3A
44	10KEY-#	1B
45	Volume Low	3B
46	Tel-index	29
47	Resolution	21
48	Mode	28
49	Help/Broadcast	30
50	On/Off Line	19
51	FF/Cont	11
52	Print Priority	18
53	Test/Reset	20
54	Enlarge	01
55	Reduce	31
56	Copy	38
57	Sort	39
58	Photo	09
59	Stop	10
60	Start	08
61		3D

ZL PANEL KEY MATRIX REFERENCE TABLE 2

	KO0 P1-1P	KO1 P1-3P	KO2 P1-5P	KO3 P1-7P	KO4 P1-9P	KO5 P1-11P	KO6 P1-13P	KO7 P1-15P
KI0 P1-16P	54	58	51	50	47	46	55	57
KI1 P1-12P	33	37	38	42	25	30	34	43
KI2 P1-10P	35	40	39	44	26	27	31	45
KI3 P1-6P	12	17	21	20	8	4	16	22
KI4 P1-2P	6	5	13	18	1 / 63	2 / 62	9	61
KI5 P1-4P	11	10	15	19	7	3 / 64	14	
KI6 P1-8P	28	32	36	41	24	23	29	
KI7 P1-14P	60	59	52	53	48	49	56	

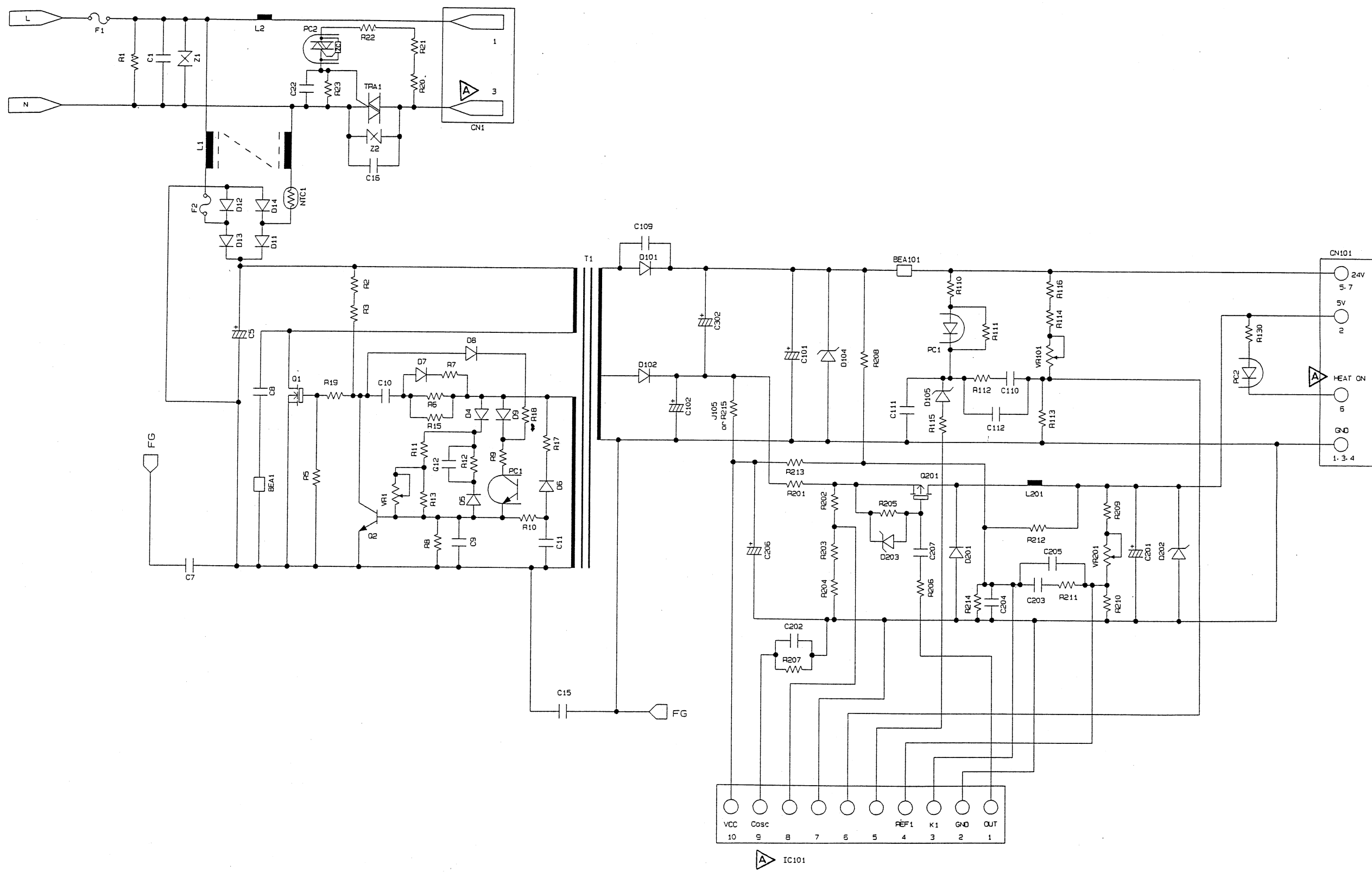

E Power Supply PCB (100-120V)  
Low-voltage power supply

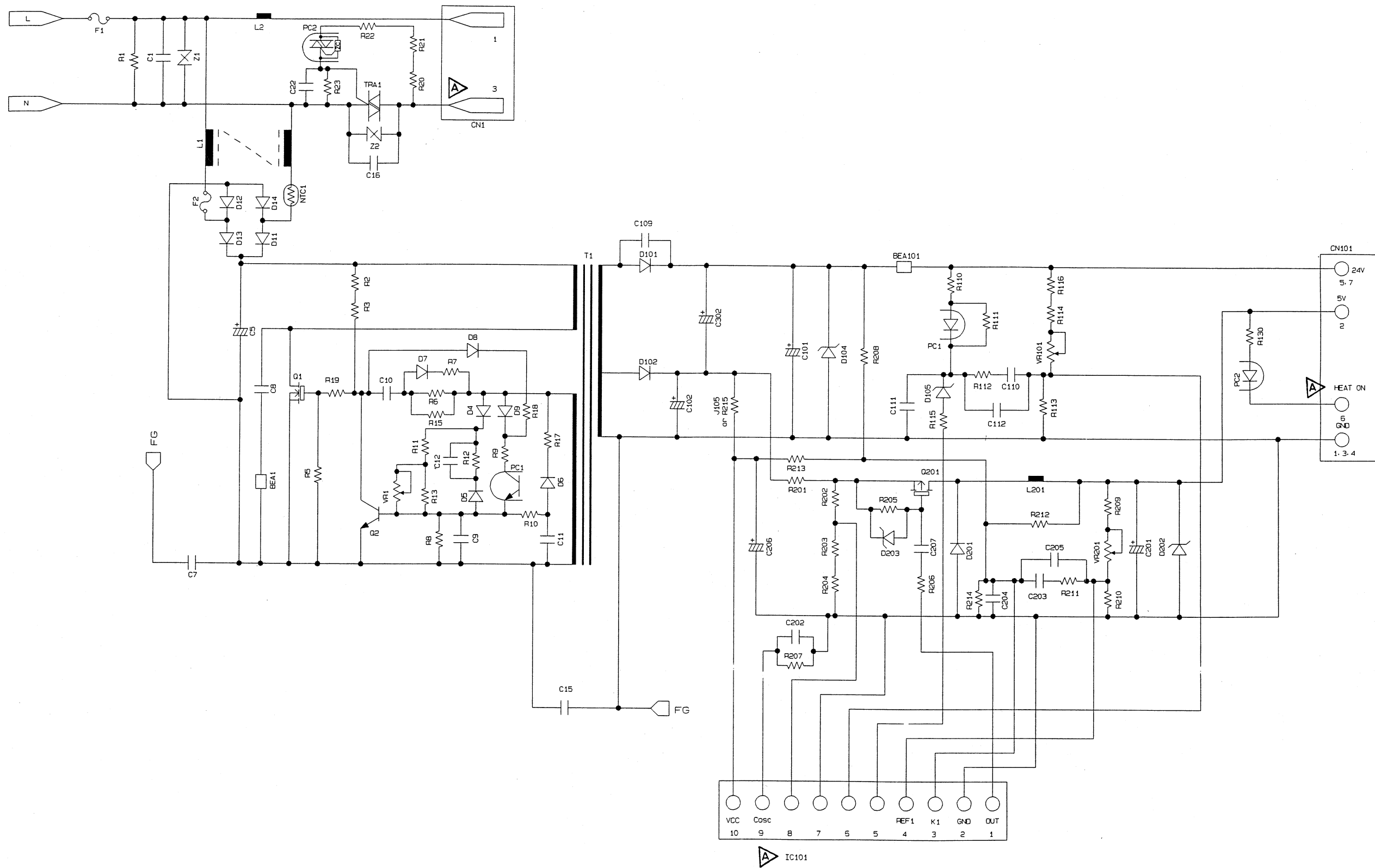

E	Power Supply PCB (200-240V) Low-voltage power supply
---	---

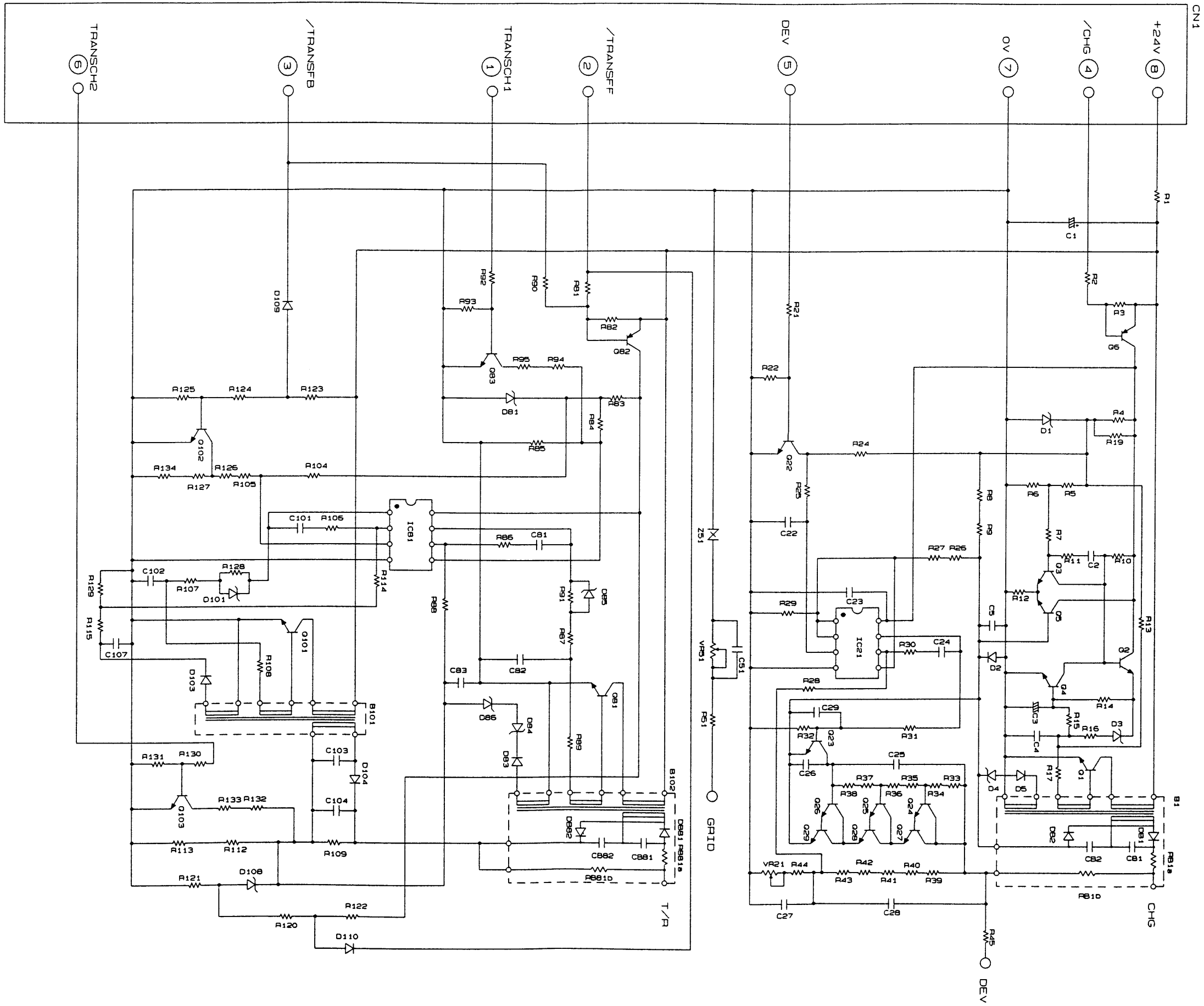

E Power Supply PCB  
High-voltage power supply

**MFC8500/FAX4100/FAX4750e/FAX5750e  
MFC9660/FAX8360P**

## **Appendix 4. Toner Cartridge Weight**

The table below lists the approximate weights of toner cartridges and toner contained in them. The weight of each toner cartridge may vary by  $\pm 2$  to 3 g depending upon the weight of the cartridge casing.

Toner cartridge type Measurement conditions	TN430		TN460	
	Total weight (incl. toner)	Toner weight	Total weight (incl. toner)	Toner weight
Brand new	775 g	145 $\pm$ 5 g	820 g	190 $\pm$ 5 g
At toner near empty	720 to 725 g	90 to 95 g	720 to 725 g	90 to 95 g
At toner empty	710 to 715 g	80 to 85 g	710 to 715 g	80 to 85 g

The above weights do not include the weight of a yellow protector.

**NOTE:** The number of pages printable per 10 g toner is 500 to 600.

**brother**®

June '02  
SM-FAX001③  
8X5513  
Printed in Japan