

Quick Setup Guide

FAX-878

1 Packing List

Make sure you have the items shown below.

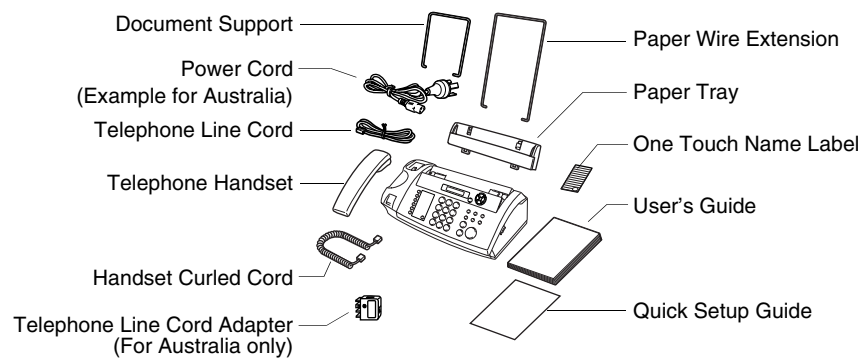

Keep the packing materials for possible future transport. If you do not pack the machine properly, it could damage your fax and may void your warranty.

2 Attach the paper wire extension and paper tray

1. Insert the document support into the openings as shown in the illustration.



2. Attach the paper wire extension.

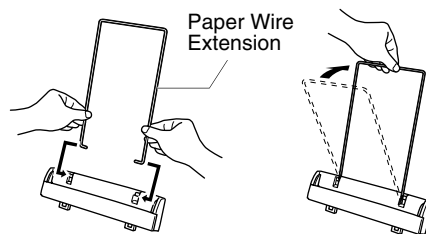

3. Attach the paper tray.

Make sure the wide pins on the paper tray are inserted firmly into the pockets on the top edge of your machine.

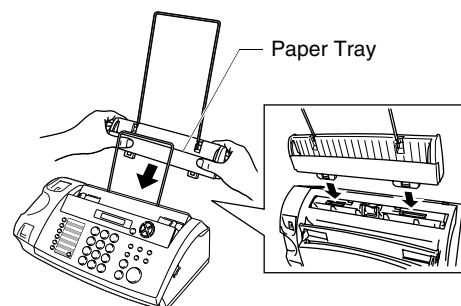

3 Load the Paper

Place up to 30 (64 g/m² - 90 g/m²) sheets of paper in the paper tray.

Gently insert paper.

The side to be printed on must be face down.

Tap the stack of paper so the edges are even.

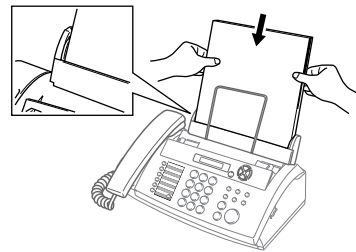
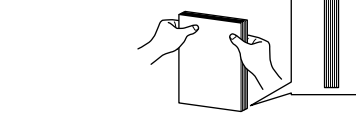

Acceptable Paper

Size: A4

Weight: 64 to 90 g/m²

Thickness: 0.08 to 0.12 mm

4 Connect the handset, power cord and telephone line cord

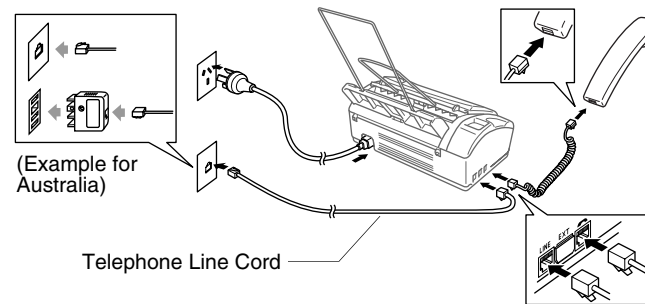

1. Connect the handset.
2. Connect the power cord to the machine.
3. Plug the power cord into an electrical socket.
4. Connect the telephone line cord to the machine in the socket marked LINE.

5 If you are sharing one phone line with an external telephone answering device, connect it now as shown below.

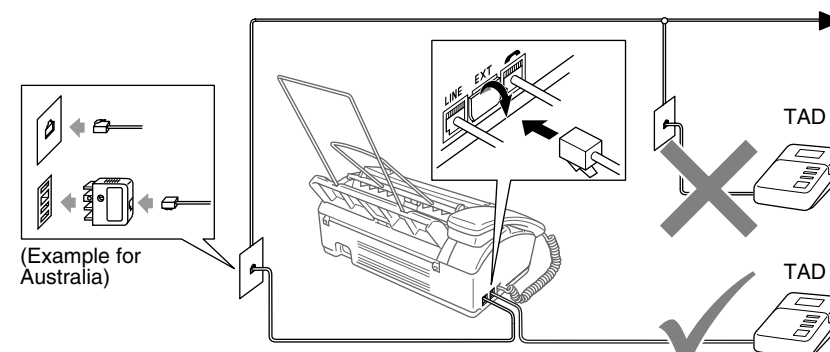

Before you connect the external telephone answering machine, remove the protective film from the EXT. jack on the machine.

For more details, see Chapter 1, "Connecting an External Telephone Answering Device (TAD)" in the User's Guide.

6 Set Date and Time

1. Press **Menu/Set**, 1, 2.
2. Enter the last two digits of the year, and then press **Menu/Set**.
3. Enter two digits for the month, and then press **Menu/Set**.
4. Enter two digits for the day, and then press **Menu/Set**.
5. Enter the time in 24-hour format, and then press **Menu/Set**.
6. Press **Stop/Exit**.

2 . DATE / TIME

ENTER YEAR : 20 --

ENTER MONTH : --

ENTER DAY : --

ENTER TIME : -- : --

7 Set Station ID

1. Press **Menu/Set**, 1, 3.
2. Enter your fax number (up to 20 digits), and then press **Menu/Set**.
3. Enter your telephone number (up to 20 digits), and then press **Menu/Set**.
4. Enter your name (up to 20 characters) using the dial pad and the chart, and then press **Menu/Set**.

3 . STATION ID

FAX :

TEL :

NAME :

To enter a space press twice.

5. Press **Stop/Exit**.

Press Key	once	twice	three times	four times	five times
2	A	B	C	2	A
3	D	E	F	3	D
4	G	H	I	4	G
5	J	K	L	5	J
6	M	N	O	6	M
7	P	Q	R	7	P
8	T	U	V	8	T
9	W	X	Y	9	W

8 Select Receive Mode

Choose the mode that best suits your needs by pressing **Receive Mode** repeatedly until the screen displays the setting you want to use.

FAX ONLY

For use with a dedicated fax line. Every call is answered as a fax.

FAX/TEL

For receiving fax and voice calls on one line.

TAD : ANSWER MACH.

For use with an external answering device. The TAD answers every call and stores voice messages. Fax messages are printed.

MANUAL

For receiving fax and voice calls on one line. You control the phone line and must answer every call yourself.

For more details, see Chapter 5, "Choosing the Receive Mode" in the User's Guide.

