



# Color Printer SERVICE MANUAL

---

---

**MODEL: HL-3040CN/3070CW**

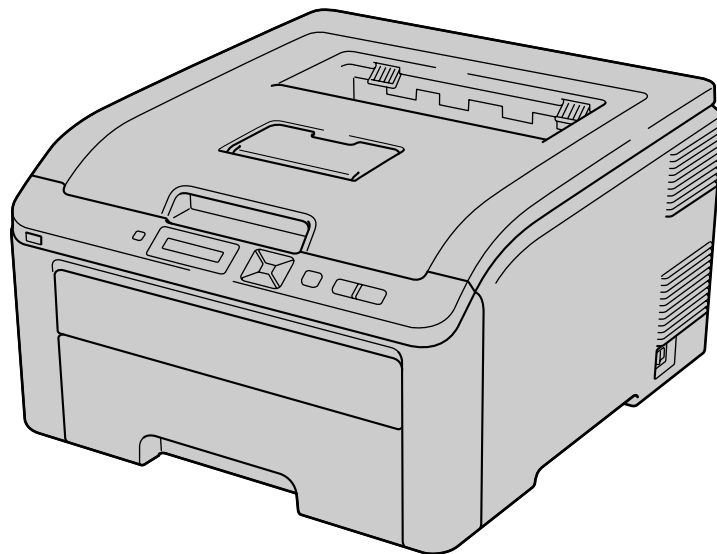

Read this manual thoroughly before maintenance work.  
Keep this manual in a convenient place for quick and easy reference at all times.

July 2009  
SM-PRN073  
84E201  
(2)

# TRADEMARKS

The Brother logo is a registered trademark of Brother Industries, Ltd.

Apple and Macintosh are trademarks of Apple Inc., registered in the United States and other countries.

PCL is either a trademark or a registered trademark of Hewlett-Packard Company in the United States and other countries.

Windows Vista is either a registered trademark or a trademark of Microsoft Corporation in the United States and/or other countries.

Microsoft, Windows, Windows Server and Internet Explorer are registered trademarks of Microsoft Corporation in the United States and/or other countries.

Linux is a registered trademark of Linus Torvalds in the United States and other countries.

PostScript and PostScript3 are either registered trademarks or trademarks of Adobe Systems Incorporated in the United States and/or other countries.

ENERGY STAR is a U.S. registered mark.

Citrix and MetaFrame are registered trademarks of Citrix Systems, Inc. in the United States.

Intel, Intel Xeon and Pentium are trademarks or registered trademarks of Intel Corporation.

AMD, AMD Athlon, AMD Opteron and combinations thereof, are trademarks of Advanced Micro Devices, Inc.

PictBridge is a trademark.

Each company whose software title is mentioned in this manual has a Software License Agreement specific to its proprietary programs.

All other trademarks are the property of their respective owners.

© Copyright Brother 2009

All rights reserved.

No part of this publication may be reproduced in any form or by any means without permission in writing from the publisher.

All other product and company names mentioned in this manual are trademarks or registered trademarks of their respective holders.

Specifications are subject to change without notice.

# PREFACE

This service manual contains basic information required for after-sales service of the printer (hereinafter referred to as “the machine”). This information is vital to the service personnel to maintain the high printing quality and performance of the machine.

This service manual covers the **HL-3040CN/3070CW machines**.

This manual consists of the following chapters:

## **CHAPTER 1: SPECIFICATIONS**

This chapter lists the specifications of each model.

## **CHAPTER 2: THEORY OF OPERATION**

Gives an overview of the printing mechanisms as well as the sensors, actuators, and control electronics. It aids in understanding the basic principles of operations as well as locating defects for troubleshooting.

## **CHAPTER 3: ERROR INDICATION AND TROUBLESHOOTING**

Details of error messages and codes that the incorporated self-diagnostic function of the machine will display if any error or malfunction occurs. If any error message appears, refer to this chapter to find which parts should be checked or replaced.

The latter half of this chapter provides sample problems that could occur in the main sections of the machine and related troubleshooting procedures.

## **CHAPTER 4: PERIODICAL MAINTENANCE**

Details of consumable parts and periodical maintenance parts. This chapter also covers procedures for disassembling and assembling periodical maintenance parts.

## **CHAPTER 5: DISASSEMBLY AND ASSEMBLY**

Details of procedures for disassembling and assembling of the machine together with related notes. The disassembly order flow provided enables you to see at a glance the quickest way to get to parts involved.

At the start of a disassembly job, you can check the disassembly order flow that guides you through a shortcut to get to the object parts.

This chapter also covers screw tightening torques and lubrication points to which the specified lubrications should be applied during assembly jobs.

## **CHAPTER 6: ADJUSTMENTS AND UPDATING OF SETTINGS, REQUIRED AFTER PARTS REPLACEMENT**

Details of adjustments and updating of settings, which are required if the main PCB and some other parts have been replaced. This chapter also covers how to update the firmware.

## **CHAPTER 7: SERVICE FUNCTIONS**

Describes the maintenance mode which is exclusively designed for the purpose of checking the settings and adjustments using the buttons on the control panel.

This chapter also covers not-disclosed-to-users function menus, which activate settings and functions or reset the parts life.

## **CHAPTER 8: CIRCUIT DIAGRAMS & WIRING DIAGRAM**

Provides the Circuit Diagrams and Wiring Diagram for the connections of the PCBs.

## **APPENDIX 1: WORKER SWITCH (WSW)**

Describes the functions of the worker switches.

## **APPENDIX 2: DELETION OF USER SETTING INFORMATION etc.**

Provides instructions on how to delete user setting information etc. stored in the machine.

## **APPENDIX 3: SERIAL NUMBERING SYSTEM**

## **APPENDIX 4: SCREW CATALOGUE**

## **APPENDIX 5: REFERENCES**

## **APPENDIX 6: GLOSSARY**

Information in this manual is subject to change due to improvement or redesign of the product. All relevant information in such cases will be supplied in service information bulletins (Technical Information).

A thorough understanding of this machine, based on information in this service manual and service information bulletins, is required for maintaining its print quality performance and for improving the practical ability to find the cause of problems.



# REGULATION

## For Europe and Other Countries

### ■ Radio interference (220 to 240 volt model only)

This machine follows EN55022 (CISPR Publication 22)/Class B.

Before you use this product, make sure that you use the following interface cable.

- A USB cable.

The cable must not be more than 2 meters long.

### ■ EU Directive 2002/96/EC and EN50419

(European Union only)

This equipment is marked with the recycling symbol below. It means that at the end of the life of the equipment you must dispose of it separately at an appropriate collection point and not place it in the normal domestic unsorted waste stream. This will benefit the environment for all.



## For USA and Canada

### ■ Federal Communications Commission (FCC) Declaration of Conformity (For USA)

Responsible Party: Brother International Corporation  
100 Somerset Corporate Boulevard  
P.O. Box 6911  
Bridgewater, NJ 08807-0911  
USA  
Telephone: (908) 704-1700

declares, that the products

Product name: Printer HL-3040CN and HL-3070CW  
Model number: HL-30C

complies with Part 15 of the FCC Rules. Operation is subject to the following two conditions: (1) This device may not cause harmful interference, and (2) this device must accept any interference received, including interference that may cause undesired operation.

This equipment has been tested and found to comply with the limits for a Class B digital device, pursuant to Part 15 of the FCC Rules. These limits are designed to provide reasonable protection against harmful interference in a residential installation. This equipment generates, uses, and can radiate radio frequency energy and, if not installed and used in accordance with the instructions, may cause harmful interference to radio communications. However, there is no guarantee that interference will not occur in a particular installation. If this equipment does cause harmful interference to radio or television reception, which can be determined by turning the equipment off and on, the user is encouraged to try to correct the interference by one or more of the following measures:

- Reorient or relocate the receiving antenna.
- Increase the separation between the equipment and receiver.
- Connect the equipment into an outlet on a circuit different from that to which the receiver is connected.
- Consult the dealer or an experienced radio/TV technician for help.

#### **Important**

A shielded interface cable should be used to ensure compliance with the limits for a Class B digital device. Changes or modifications not expressly approved by Brother Industries, Ltd. could void the user's authority to operate the equipment.

### ■ Industry Canada Compliance Statement (For Canada)





This Class B digital apparatus complies with Canadian ICES-003.

Cet appareil numérique de la classe B est conforme à la norme NMB-003 du Canada.

# SAFETY INFORMATION

## ■ Definitions of Warnings, Cautions, Notes and Memos

The following conventions are used in this manual:

Mark	Contents
	Warnings tell you what to do to prevent possible personal injury.
	Electrical Hazard icons alert you to a possible electrical shock.
	Hot Surface icons warn you not to touch machine parts that are hot.
	Cautions specify procedures you must follow or avoid to prevent possible damage to the machine or other objects.
<b>Note</b>	Notes tell you useful tips when servicing the machine.
<b>Memo</b>	Memo tells you bits of knowledge to help understand the machine.

## ■ Safety Precautions

Listed below are the various kinds of “WARNING” messages included in this manual.

### **WARNING**



There are high voltage electrodes inside the machine. Before you clean the inside of the machine or replace parts, make sure that you have turned off the power switch and unplugged the machine from the AC power outlet.

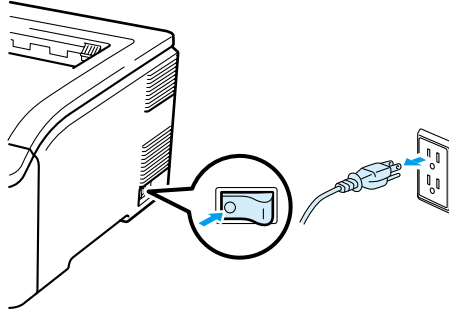

DO NOT handle the plug with wet hands. Doing this might cause an electrical shock.

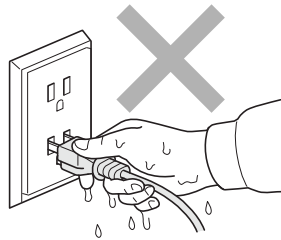

The fuser unit becomes extremely hot during operation. Wait until it has cooled down sufficiently before replacing consumable items. DO NOT remove or damage the caution label located on or around the fuser.

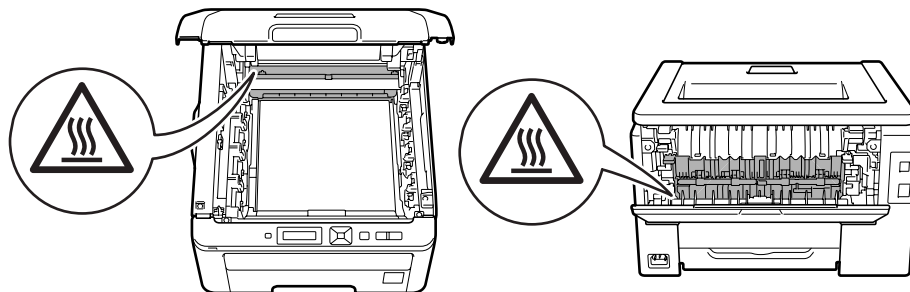

**! WARNING**

DO NOT use flammable substances, any type of spray or any organic solvent/liquids contains alcohol or ammonia to clean the inside or outside of the machine. Doing this may cause a fire or electrical shock.



If the machine becomes hot, blows smoke, or generates obscure odor, immediately turn off the power switch and unplug the machine from the AC power outlet.

If metal objects, water or other liquids get inside the machine, immediately turn off the power switch and unplug the machine from the AC power outlet.

This machine is heavy and weighs approximately 19.0 kg (41.9 lb). To prevent injuries when moving or lifting this machine, make sure to use at least two people. Be careful not to pinch your fingers when you set the machine back down.

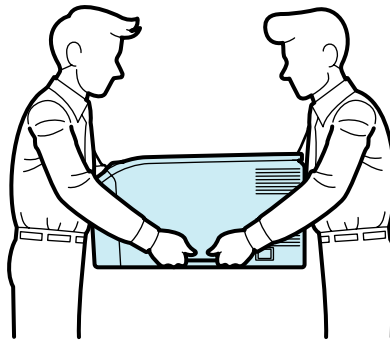

**! CAUTION**

Lightning and power surges can damage this product! We recommend that you use a quality surge protection device on the AC power line, or unplug the machine during a lightning storm.

Violently closing the top cover without mounting the toner cartridge and the drum unit can damage this product.

# **CHAPTER 1**

## **SPECIFICATIONS**

# CHAPTER 1

## SPECIFICATIONS

This chapter lists the specifications of each model.

### CONTENTS

<b>1. COMPONENTS .....</b>	<b>1-1</b>
<b>2. SPECIFICATIONS LIST .....</b>	<b>1-2</b>
2.1 General .....	1-2
2.2 Network Connectivity .....	1-6
2.3 Service Information .....	1-9
2.4 Consumables .....	1-10
2.5 Paper .....	1-11
2.5.1 Paper handling .....	1-11
2.5.2 Media specifications .....	1-11
2.5.3 Type and size of paper .....	1-12
2.6 Printable Area .....	1-13
2.7 Print Speeds with Various Settings .....	1-21

# 1. COMPONENTS

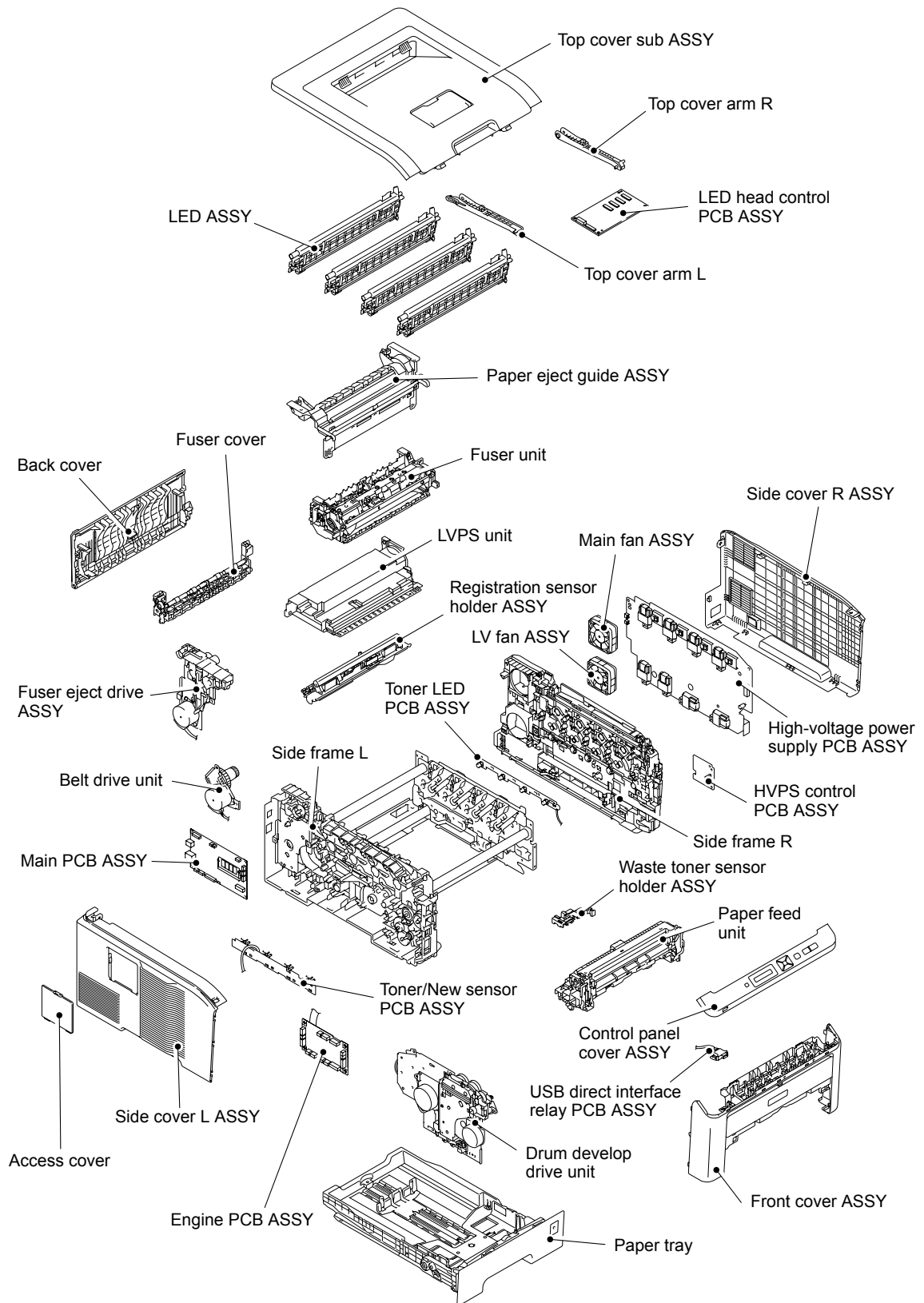

Fig. 1-1



## 2. SPECIFICATIONS LIST

### 2.1 General

Model		HL-3040CN	HL-3070CW
Print method		Electrophotographic LED color printer	
Resolution	2,400 dpi (600 (main scanning) x 2,400 (sub scanning)) quality	Windows Server® 2008, Windows Vista®, Windows Server® 2003 x64 Edition, Windows® XP Professional x64 Edition, Windows Server® 2003, Windows® XP Home Edition/Professional, Windows® 2000, Mac OS® X 10.3.9 or greater	
	600 (main scanning) x 600 (sub scanning) dpi	Windows Server® 2008, Windows Vista®, Windows Server® 2003 x64 Edition, Windows® XP Professional x64 Edition, Windows Server® 2003, Windows® XP Home Edition/Professional, Windows® 2000, Mac OS® X 10.3.9 or greater, Linux	Windows Server® 2008, Windows Vista®, Windows Server® 2003 x64 Edition, Windows® XP Professional x64 Edition, Windows Server® 2003, Windows® XP Home Edition/Professional, Windows® 2000, Mac OS® X 10.3.9 or greater, DOS, Linux
Print mode		Normal printing mode Economy printing mode (Toner saving mode)	
Print Speed	One side	Monochrome/Full Color: Up to 16/16 ppm (A4 size), Up to 17/17 ppm (Letter size) * When loading A4 or Letter-size paper from the paper tray.	
	Duplex	N/A	
Warm-up time* <sup>1</sup>		From Sleep Mode: Less than 27 seconds From Power OFF → ON: Less than 37 seconds	
First print time* <sup>1</sup>		Monochrome: Less than 15 seconds Full Color: Less than 16 seconds	
CPU		300 MHz	
Memory	Standard	32 MB	64 MB
	Option	1 DIMM slot; expandable up to 544 MB	1 DIMM slot; expandable up to 576 MB
Interface		Hi-Speed USB 2.0, Ethernet 10/100 BASE-TX	Hi-Speed USB 2.0, Ethernet 10/100 BASE-TX, Wireless LAN IEEE 802.11 b/g

\*<sup>1</sup> The time may change if the machine is performing adjustment of color density or adjustment of color registration.

**Note:**

Print speed varies depending on the paper size or media type. For details, refer to ["2.7 Print Speeds with Various Settings" in this chapter.](#)

Specifications are subject to change without notice.

Model		HL-3040CN	HL-3070CW
Power consumption	Printing	Average 480 W at 25 °C (77 °F)	
	Ready	Average 70 W at 25 °C (77 °F)	
	Sleep	Average 8 W at 25 °C (77 °F)	Average 10 W at 25 °C (77 °F)
Noise level	Sound Pressure	Printing: 53 dB (A) Ready: 30 dB (A)	
	Sound power	Monochrome printing: LWAd = 6.34 Bell (A) Color printing: LWAd = 6.29 Bell (A) Ready: LWAd = 3.64 Bell (A)	
Temperature		Operating: 10 to 32.5 °C (50 to 90.5 °F) Non operating: 0 to 40 °C (38 to 104 °F) Storage: -20 to 40 °C (-4 to 104 °F)	
Humidity		Operating: 20 to 80 % (non condensing) Storage: 10 to 85 % (non condensing)	
Dimensions (W × D × H)		409 x 466 x 250 mm (16.1 x 18.3 x 9.8 inch)	
Weight		Approximately 19.0 kg (41.9 lb) including the drum unit, toner cartridge, belt unit and waste toner box.	

Specifications are subject to change without notice.

**<PC Software>**

Model		HL-3040CN	HL-3070CW
Printer driver	Windows®	Host-Based Driver for Windows Server® 2008, Windows Vista®, Windows Server® 2003 x64 Edition, Windows® XP Professional x64 Edition, Windows Server® 2003, Windows® XP Home Edition/Professional, Windows® 2000 Professional	
		N/A	BR-Script 3 (PPD file for Windows Server® 2008, Windows Vista®, Windows Server® 2003 x64 Edition, Windows® XP Professional x64 Edition, Windows Server® 2003, Windows® XP Home Edition/Professional, Windows® 2000 Professional)
	Macintosh®	Macintosh Printer Driver for Mac OS® X 10.3.9 or greater	
		N/A	BR-Script 3 (PPD file for Mac OS® X 10.3.9 or greater)
	Linux	Linux printer driver for CUPS printing system (x86, x64 environment)	
		Linux printer driver for LPD/LPRng printing system (x86, x64 environment)	

**<Direct Print feature>**

Model	HL-3040CN	HL-3070CW
Direct Print	N/A	PDF version 1.7* <sup>1</sup> , JPEG, Exif+JPEG, PRN (created by HL-3040CN or HL-3070CW printer driver), TIFF (scanned by all Brother MFC or DCP models), PostScript® 3™ (created by HL-3070CW BRScript3 printer driver), XPS version 1.0

\*<sup>1</sup> The data including JBIG2 image files, JPEG2000 image files and transparency files are not supported.

Specifications are subject to change without notice.

**<System requirements>**

Computer Platform & Operating System Version		Processor Speed	Minimum RAM	Recommended RAM	Available Hard Disk Space
Windows®	Windows Server® 2008	Intel® Pentium® 4 or equivalent 64-bit (Intel® 64 or AMD64) supported CPU	512 MB	2 GB	50 MB
	Windows Vista®		512 MB	1 GB	50 MB
	Windows Server® 2003 x64 Edition	64-bit (Intel® 64 or AMD64) supported CPU	256 MB	512MB	50 MB
	Windows® XP Professional x64 Edition				
	Windows Server® 2003	Intel® Pentium® III or equivalent	256 MB	512MB	50 MB
	Windows® XP Home Edition	Intel® Pentium® II or equivalent	128 MB	256 MB	50 MB
	Windows® XP Professional				
	Windows® 2000 Professional		64 MB	256 MB	50 MB
Macintosh®	Mac OS® X 10.4.4 or greater	Power PC G4/G5, Intel® Core™ Processor	512 MB	1 GB	80 MB
	Mac OS® X 10.3.9 - 10.4.3	Power PC G4/G5, Power PC G3 350MHz	128 MB	256 MB	

Specifications are subject to change without notice.

## 2.2 Network Connectivity

### <Wired network>

Network node type	NC-6700h	
Operating system support	Windows Server® 2008, Windows Vista®, Windows Server® 2003 x64 Edition, Windows® XP Professional x64 Edition, Windows Server® 2003, Windows® XP Home Edition/Professional, Windows® 2000 Professional, Mac OS® X 10.3.9 or greater	
Protocol support	TCP/IP: IPv4	ARP, RARP, BOOTP, DHCP, APIPA (Auto IP), WINS/NetBIOS name resolution, DNS resolver, mDNS, LLNMR responder, LPR/LPD, Custom Raw Port/Port9100, IPP/IPPS, FTP Server, TELNET Server, HTTP/HTTPS server, TFTP client and server, SMTP Client, APOP, POP before SMTP, SMTP-AUTH, SNMPv1/v2c/v3, ICMP, LLTD responder, Web Services Print, SSL/TLS, CIFS client, SNTP, FTP client
	TCP/IP: IPv6*1	(Turned off as default) NDP, RA, DNS resolver, mDNS, LLNMR responder, LPR/LPD, Custom Raw Port/Port9100, IPP/IPPS, FTP Server, TELNET Server, HTTP/HTTPS server, TFTP client and server, SMTP Client, APOP, POP before SMTP, SMTP-AUTH, SNMPv1/v2c/v3, ICMPv6, LLTD responder, Web Services Print, SSL/TLS, CIFS client, SNTP, FTP client
Network type	Ethernet 10/100 BASE-TX Auto Negotiation	
Network printing	Windows Server® 2008, Windows Vista®, Windows Server® 2003, Windows® XP and Windows® 2000 TCP/IP printing Mac OS® X 10.3.9 or greater printing	
Management utility	BRAdmin Professional 3*2	Windows Server® 2008, Windows Vista®, Windows Server® 2003 x64 Edition, Windows® XP Professional x64 Edition, Windows Server® 2003, Windows® XP Home Edition/Professional Edition, Windows® 2000 Professional
	Web BRAdmin*2	Windows Server® 2008, Windows Vista®, Windows Server® 2003 x64 Edition, Windows® XP Professional x64 Edition, Windows Server® 2003, Windows® XP Home Edition/Professional Edition, Windows® 2000 Professional
	Web Based Management	Microsoft Internet Explorer 6.0 (or greater), Firefox 1.0 (or greater) for Windows, and Safari 1.2 (or greater) for Macintosh are recommended.
	BRAdmin Light	Windows Server® 2008, Windows Vista®, Windows Server® 2003 x64 Edition, Windows® XP Professional x64 Edition, Windows Server® 2003, Windows® XP Home Edition/Professional Edition, Windows® 2000 Professional Mac OS® X 10.3.9 or greater

\*1 If you want to use the IPv6 protocol, visit <http://solutions.brother.com/> for more information.

\*2 BRAdmin Professional and Web BRAdmin are available as a download from <http://solutions.brother.com/>

Specifications are subject to change without notice.

**<Wireless network> (HL-3070CW only)**

Network node type	NC-7500w	
Operating system support	Windows Server® 2008, Windows Vista®, Windows Server® 2003 x64 Edition, Windows® XP Professional x64 Edition, Windows Server® 2003, Windows® XP Home Edition/Professional, Windows® 2000 Professional, Mac OS® X 10.3.9 or greater	
Protocol support	TCP/IP: IPv4	ARP, RARP, BOOTP, DHCP, APIPA (Auto IP), WINS/NetBIOS name resolution, DNS resolver, mDNS, LLNMR responder, LPR/LPD, Custom Raw Port/Port9100, IPP/IPPS, FTP Server, TELNET Server, HTTP/HTTPS server, TFTP client and server, SMTP Client, APOP, POP before SMTP, SMTP-AUTH, SNMPv1/v2c/v3, ICMP, LLTD responder, Web Services Print, SSL/TLS
	TCP/IP: IPv6* <sup>3</sup>	NDP, RA, DNS resolver, mDNS, LLNMR responder, LPR/LPD, Custom Raw Port/Port9100, IPP/IPPS, FTP Server, TELNET Server, HTTP/HTTPS server, TFTP client and server, SMTP Client, APOP, POP before SMTP, SMTP-AUTH, SNMPv1/v2c/v3, ICMPv6, LLTD responder, Web Services Print, SSL/TLS
Network type	IEEE 802.11 b/g wireless	
Frequency	2412 - 2472 MHz	
RF channels	US/Canada	1 - 11
	Japan	802.11 b: 1 - 14, 802.11 g: 1 - 13
	Others	1 - 13
Communication mode	Infrastructure, Ad-hoc (802.11 b only)	
Data rate	802.11 b	11/5.5/2/1 Mbps
	802.11 g	54/48/36/24/18/12/11/9/6/5.5/2/1 Mbps
Link distance	70 m (233 ft.) at lowest data rate (The distance rate will vary upon environment and other equipment location.)	
Network security	SSID/ESSID, WEP 64/128bit, WPA-PSK (TKIP/AES), WPA2-PSK (AES), LEAP (CKIP), EAP-FAST (TKIP/AES)	
Network printing	Windows Vista®, Windows Server® 2003, Windows® XP and Windows® 2000 TCP/IP printing Mac OS® X 10.3.9 or greater printing	

\*<sup>3</sup> If you want to use the IPv6 protocol, visit <http://solutions.brother.com/> for more information.

Specifications are subject to change without notice.

Management utility	BRAdmin Professional 3 <sup>*4</sup>	Windows Server® 2008, Windows Vista®, Windows Server® 2003 x64 Edition, Windows® XP Professional x64 Edition, Windows Server® 2003, Windows® XP Home Edition/Professional Edition, Windows® 2000 Professional
	Web BRAdmin <sup>*4</sup>	Windows Server® 2008, Windows Vista®, Windows Server® 2003 x64 Edition, Windows® XP Professional x64 Edition, Windows Server® 2003, Windows® XP Home Edition/Professional Edition, Windows® 2000 Professional
	Web Based Management	Microsoft Internet Explorer 6.0 (or greater), Firefox 1.0 (or greater) for Windows, and Safari 1.2 (or greater) for Macintosh are recommended.
	BRAdmin Light	Windows Server® 2008, Windows Vista®, Windows Server® 2003 x64 Edition, Windows® XP Professional x64 Edition, Windows Server® 2003, Windows® XP Home Edition/Professional Edition, Windows® 2000 Professional Mac OS® X 10.3.9 or greater

<sup>\*4</sup> BRAdmin Professional and Web BRAdmin are available as a download from <http://solutions.brother.com/>

Specifications are subject to change without notice.

## 2.3 Service Information

These are key service information to maintain the product.

- Machine life: approximately 100,000 pages or 5 years
- MTBF (Meantime between failure): 4,000 hours
- MTTR (Meantime to repair): 30 minutes
- Maximum monthly volume: 25,000 pages
- Periodical maintenance parts:

Part	Approximate life (page)
Fuser unit	50,000
Paper feeding kit	50,000

\* As for replacement of the periodical maintenance parts, refer to “**PERIODICAL MAINTENANCE**” in Chapter 4.

Specifications are subject to change without notice.



## 2.4 Consumables

Model	HL-3040CN	HL-3070CW
Toner cartridge	Life expectancy: Black Standard <sup>*1</sup> : Approximately 2,200 pages/cartridge Black Starter <sup>*2</sup> : Approximately 1,000 pages/cartridge Cyan, Magenta, Yellow Standard <sup>*1</sup> : Approximately 1,400 pages/cartridge Cyan, Magenta, Yellow Starter <sup>*2</sup> : Approximately 1,000 pages/cartridge * When printing A4/Letter-size paper in accordance with ISO/IEC 19798. Shelf life: 2 years without opening (6 months after opening)	
Drum unit	Life expectancy: Approximately 15,000 <sup>*3</sup> pages/drum unit The life expectancy varies according to the use condition. * When printing A4/Letter-size paper. Shelf life: 2 years without opening (6 months after opening)	
Belt unit	Life expectancy: Approximately 50,000 pages/belt unit The life expectancy varies according to the use condition.	
Waste toner box	Life expectancy: Approximately 50,000 pages/waste toner box	
The shelf life of toner cartridge and drum unit is guaranteed under the normal condition as below; (Temperature) Normal condition: 0 to 40 °C * Storage condition at the temperature of 40 to 50 °C: Up to 5 days * Storage condition at the temperature of -20 to 0 °C: Up to 5 days (Humidity) Normal condition: 35 to 85 % * Storage condition at the humidity of 85 to 95 %: Up to 5 days * Storage condition at the humidity of 10 to 35 %: Up to 5 days		

\*1 Separately sold consumable toner

\*2 Toner supplied with the machine

\*3 In the normal use, the color photosensitive drums rotate simultaneously even if no color print is made at all and black print only is made. Thus, the four color drum units reach the life expectancy at the same time.

Specifications are subject to change without notice.

## 2.5 Paper

### 2.5.1 Paper handling

Model		HL-3040CN	HL-3070CW
Paper Input <sup>*1</sup>	Paper tray	250 sheets	
	Manual feed slot	1 sheet	
	Option	N/A	
Paper Output <sup>*1</sup>	Face-down	100 sheets	
	Face-up	1 sheet (Straight paper path)	
Duplex	Manual duplex <sup>*2</sup>	Yes	
	Automatic duplex	N/A	

<sup>\*1</sup> Calculated with 80 g/m<sup>2</sup> (20 lb) paper

<sup>\*2</sup> Not supported for Linux driver and PS driver (except Mac PS driver)

### 2.5.2 Media specifications

Model		HL-3040CN	HL-3070CW
Media type	Paper tray	Plain paper, Thin paper, Recycled paper	
	Manual feed slot	Plain paper, Thin paper, Thick paper, Thicker paper, Recycled paper, Bond paper, Label, Envelopes, Env. Thin, Env. Thick	
Media weight	Paper tray	60 to 105 g/m <sup>2</sup> (16 to 28 lb)	
	Manual feed slot	60 to 163 g/m <sup>2</sup> (16 to 43 lb)	
Media size	Paper tray	A4, Letter, B5 (ISO), A5, A5 (Long Edge), B6 (ISO), A6, Executive, Legal <sup>*3</sup> , Folio	
	Manual feed slot	Width: 76.2 to 220 mm (3.0 to 8.66 inch) Length: 116 to 406.4 mm (4.57 to 16 inch)	

<sup>\*3</sup> Legal size paper and Folio size paper are not available in some regions outside the USA and Canada.

Specifications are subject to change without notice.

## 2.5.3 Type and size of paper

The printer loads paper from the installed paper tray or the manual feed slot. The names for the paper trays in the printer driver as follows:

The name for the paper trays	The name for the paper trays in the printer driver
Paper tray	Tray1
Manual feed slot	Manual

### <Media type>

	Tray1	Manual	Choose the media type from the printer driver
<b>Plain paper</b> 75 to 105 g/m <sup>2</sup> (20 to 28 lb)	Yes	Yes	<b>Plain Paper</b>
<b>Recycled paper</b>	Yes	Yes	<b>Recycled Paper</b>
<b>Bond paper</b> Rough paper- 60 to 163 g/m <sup>2</sup> (16 to 43 lb)	N/A	Yes 60 to 163 g/m <sup>2</sup> (16 to 43 lb)	<b>Bond Paper</b>
<b>Thin paper</b> 60 to 75 g/m <sup>2</sup> (16 to 20 lb)	Yes	Yes	<b>Thin Paper</b>
<b>Thick paper</b> 105 to 163 g/m <sup>2</sup> (28 to 43 lb)	N/A	Yes	<b>Thick Paper or Thicker Paper</b>
<b>Labels</b>	N/A	Yes A4 or Letter	<b>Label</b>
<b>Envelopes</b>	N/A	Yes	<b>Envelopes, Env. Thin, Env. Thick</b>

#### Memo:

- Use paper that is made for plain-paper copying.
- Use paper that is 75 to 90 g/m<sup>2</sup> (20 to 24 lb).
- Use neutral paper. Do not use acidic or alkaline paper.
- Use long-grain paper.
- This printer can use recycled paper that meets DIN 19309 specifications.
- DO NOT use ink jet paper because it may cause a paper jam or damage your printer.

Specifications are subject to change without notice.

# 2.6 Printable Area

## ■ PCL5C emulation

When using PCL5C emulation, the edges of the paper that cannot be printed on are shown below.

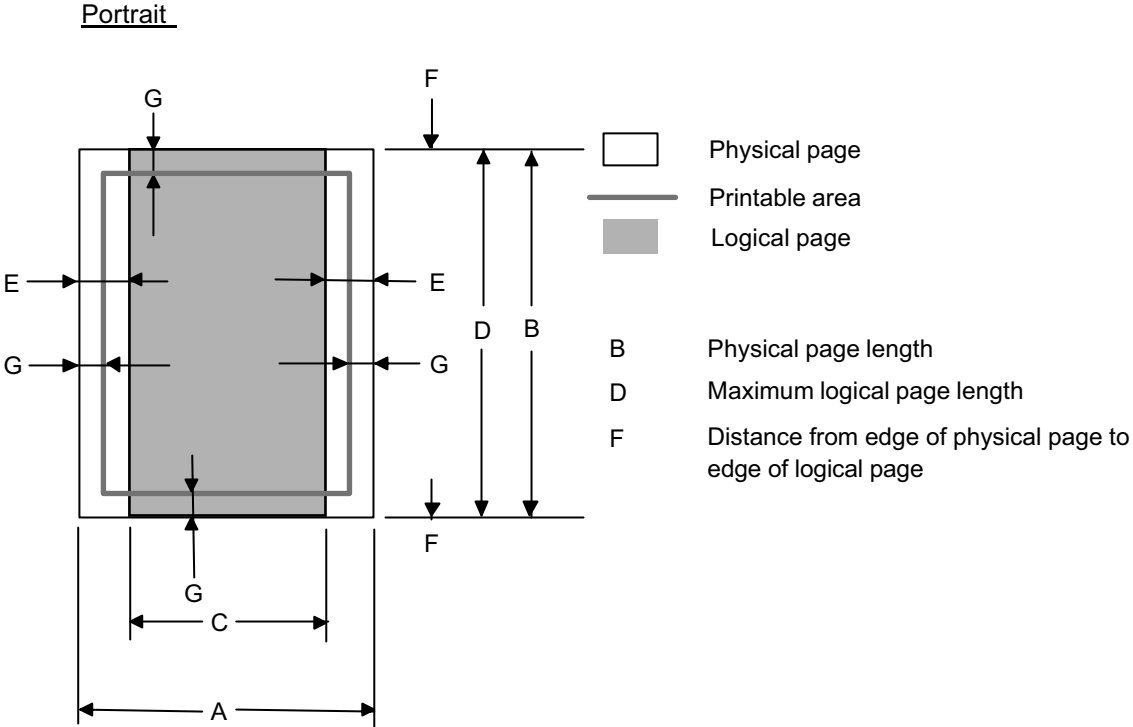

**Note:**  
Therefore, the machine can only print within the shaded area when you use a PCL driver.

Specifications are subject to change without notice.

The table below shows the printable areas when printing on Portrait for each paper size.

Size		A	B	C	D	E	F	G
<b>Letter</b>	(mm)	215.9	279.4	203.2	279.4	6.35	0	4.23
	(inch)	8.5	11	8	11	0.25	0	0.17
	(dots)	2,550	3,300	2,400	3,300	75	0	50
<b>Legal</b>	(mm)	215.9	355.6	203.2	355.6	6.35	0	4.23
	(inch)	8.5	14	8	14	0.25	0	0.17
	(dots)	2,550	4,200	2,400	4,200	75	0	50
<b>Folio</b>	(mm)	215.9	330.2	203.2	330.2	6.35	0	4.23
	(inch)	8.5	13	8	13	0.25	0	0.17
	(dots)	2,550	3,900	2,400	3,900	75	0	50
<b>Executive</b>	(mm)	184.2	266.7	171.5	266.7	6.35	0	4.23
	(inch)	7.25	10.5	6.75	10.5	0.25	0	0.17
	(dots)	2,175	3,150	2,025	3,150	75	0	50
<b>A4</b>	(mm)	210	297	198	297	6.01	0	4.23
	(inch)	8.3	11.7	7.8	11.7	0.24	0	0.17
	(dots)	2,480	3,507	2,338	3,507	71	0	50
<b>A5</b>	(mm)	148	210	136	210	6.01	0	4.23
	(inch)	5.8	8.3	5.4	8.3	0.24	0	0.17
	(dots)	1,748	2,480	1,606	2,480	71	0	50
<b>A5 Long Edge</b>	(mm)	210	148	198	148	6.01	0	4.23
	(inch)	8.3	5.8	7.8	5.8	0.24	0	0.17
	(dots)	2,480	1,748	2,338	1,748	71	0	50
<b>A6</b>	(mm)	105	148	93	148	6.01	0	4.23
	(inch)	4.1	5.8	3.7	5.8	0.24	0	0.17
	(dots)	1,240	1,748	1,098	1,748	71	0	50
<b>B5 (JIS)</b>	(mm)	182	257	170	257	6.01	0	4.23
	(inch)	7.2	10.1	6.7	10.1	0.24	0	0.17
	(dots)	2,148	3,030	2,006	3,030	71	0	50
<b>B5 (ISO)</b>	(mm)	176	250	164	250	6.01	0	4.23
	(inch)	6.9	9.8	6.5	9.8	0.24	0	0.17
	(dots)	2,078	2,952	1,936	2,952	71	0	50
<b>B6 (JIS)</b>	(mm)	128	182	116	182	6.01	0	4.23
	(inch)	5	7.2	4.6	7.2	0.24	0	0.17
	(dots)	1,511	2,149	1,369	2,149	71	0	50
<b>B6 (ISO)</b>	(mm)	125	176	113	176	6.01	0	4.23
	(inch)	4.9	6.9	4.4	6.9	0.24	0	0.17
	(dots)	1,476	2,078	1,334	2,078	71	0	50
<b>Envelope Monarch</b>	(mm)	98.4	190.5	85.7	190.5	6.35	0	4.23
	(inch)	3.875	7.5	3.375	7.5	0.25	0	0.17
	(dots)	1,162	2,250	1,012	2,250	75	0	50
<b>Envelope Com-10</b>	(mm)	104.7	241.3	92	241.3	6.35	0	4.23
	(inch)	4.125	9.5	3.625	9.5	0.25	0	0.17
	(dots)	1,237	2,850	1,087	2,850	75	0	50
<b>Envelope DL</b>	(mm)	110	220	98	220	6.01	0	4.23
	(inch)	4.3	8.7	3.9	8.7	0.24	0	0.17
	(dots)	1,299	2,598	1,157	2,598	71	0	50
<b>Envelope C5</b>	(mm)	162	229	150	229	6.01	0	4.23
	(inch)	6.4	9	5.9	9	0.24	0	0.17
	(dots)	1,913	2,704	1,771	2,704	71	0	50
<b>Hagaki</b>	(mm)	100	148	88	148	6.01	0	4.23
	(inch)	3.9	5.8	3.5	5.8	0.24	0	0.17
	(dots)	1,181	1,748	1,039	1,748	71	0	50
<b>A4 Long</b>	(mm)	210	405	198	405	6.01	0	4.23
	(inch)	8.3	15.9	7.8	15.9	0.24	0	0.17
	(dots)	2,480	4,783	2,338	4,783	71	0	50
<b>DL Long Edge</b>	(mm)	220	110	207	110	6.27	0	6.27
	(inch)	8.7	4.3	8.2	4.3	0.25	0	0.25
	(dots)	2,598	1,299	2,450	1,299	74	0	74
<b>3X5</b>	(mm)	76.2	127	63.5	127	6.35	0	4.23
	(inch)	3	5	2.5	5	0.25	0	0.17
	(dots)	900	1,500	750	1,500	75	0	50

**Note:**

- The paper sizes indicated here should confirm to the nominal dimensions specified by JIS except B5 (ISO), B6 (ISO).
- The dot size is based on 300 dpi resolution.

Specifications are subject to change without notice.

Landscape

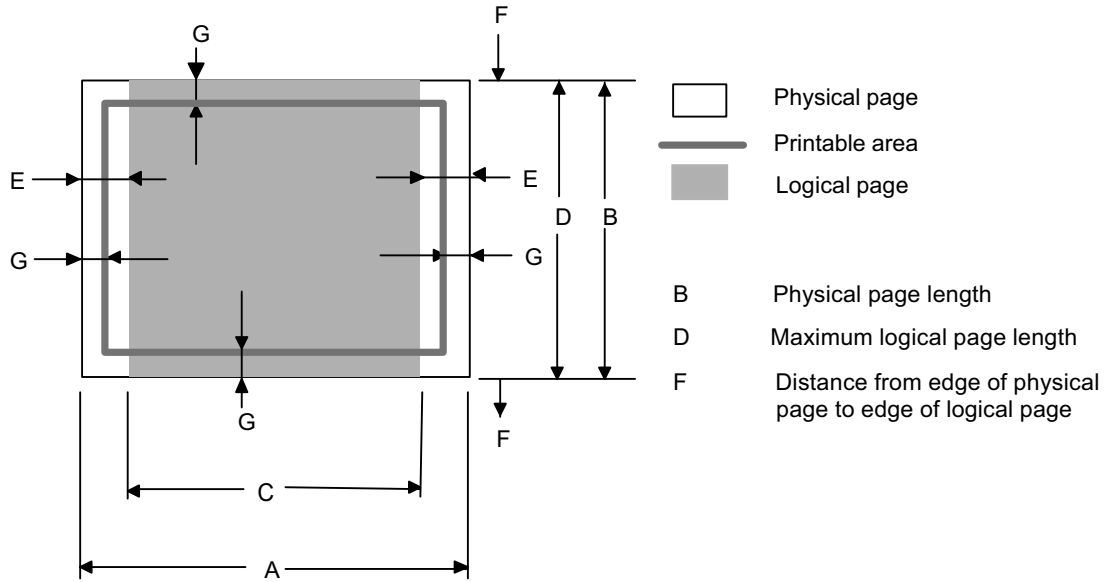

**Note:**

- "Logical page" shows the printable area for a PCL driver.
- Therefore, the machine can only print within the shaded area when you use a PCL driver.

Specifications are subject to change without notice.

The table below shows the printable areas when printing on Landscape for each paper size.

Size		A	B	C	D	E	F	G
<b>Letter</b>	(mm)	279.4	215.9	269.2	215.9	5.08	0	4.23
	(inch)	11	8.5	10.6	8.5	0.2	0	0.17
	(dots)	3,300	2,550	3,180	2,550	60	0	50
<b>Legal</b>	(mm)	355.6	215.9	345.4	215.9	5.08	0	4.23
	(inch)	14	8.5	13.6	8.5	0.2	0	0.17
	(dots)	4,200	2,550	4,080	2,550	60	0	50
<b>Folio</b>	(mm)	330.2	215.9	320	215.9	5.08	0	4.23
	(inch)	13	8.5	12.6	8.5	0.2	0	0.17
	(dots)	3,900	2,550	3,780	2,550	60	0	50
<b>Executive</b>	(mm)	266.7	184.2	256.5	184.2	5.08	0	4.23
	(inch)	10.5	7.25	10.1	7.25	0.2	0	0.17
	(dots)	3,150	2,175	3,030	2,175	60	0	50
<b>A4</b>	(mm)	297	210	287	210	5	0	4.23
	(inch)	11.7	8.3	11.3	8.3	0.2	0	0.17
	(dots)	3,507	2,480	3,389	2,480	59	0	50
<b>A5</b>	(mm)	210	148	200	148	5	0	4.23
	(inch)	8.3	5.8	7.9	5.8	0.2	0	0.17
	(dots)	2,480	1,748	2,362	1,748	59	0	50
<b>A5 Long Edge</b>	(mm)	148	210	138	210	5	0	4.23
	(inch)	5.8	8.3	5.4	8.3	0.2	0	0.17
	(dots)	1,748	2,480	1,630	2,480	59	0	50
<b>A6</b>	(mm)	148	105	138	105	5	0	4.23
	(inch)	5.8	4.1	5.4	4.1	0.2	0	0.17
	(dots)	1,748	1,240	1,630	1,240	59	0	50
<b>B5 (JIS)</b>	(mm)	257	182	247	182	5	0	4.23
	(inch)	10.1	7.2	9.7	7.2	0.2	0	0.17
	(dots)	3,030	2,148	2,912	2,148	59	0	50
<b>B5 (ISO)</b>	(mm)	250	176	240	176	5	0	4.23
	(inch)	9.8	6.9	9.4	6.9	0.2	0	0.17
	(dots)	2,952	2,078	2,834	2,078	59	0	50
<b>B6 (JIS)</b>	(mm)	182	128	172	128	5	0	4.23
	(inch)	7.2	5	6.8	5	0.2	0	0.17
	(dots)	2,149	1,511	2,031	1,511	59	0	50
<b>B6 (ISO)</b>	(mm)	176	125	166	125	5	0	4.23
	(inch)	6.9	4.9	6.5	4.9	0.2	0	0.17
	(dots)	2,078	1,476	1,960	1,476	59	0	50
<b>Envelope Monarch</b>	(mm)	190.5	98.4	180.3	98.4	5.08	0	4.23
	(inch)	7.5	3.875	7.1	3.875	0.2	0	0.17
	(dots)	2,250	1,162	2,130	1,162	60	0	50
<b>Envelope Com-10</b>	(mm)	241.3	104.7	231.1	104.7	5.08	0	4.23
	(inch)	9.5	4.125	9.1	4.125	0.2	0	0.17
	(dots)	2,850	1,237	2,730	1,237	60	0	50
<b>Envelope DL</b>	(mm)	220	110	210	110	5	0	4.23
	(inch)	8.7	4.3	8.3	4.3	0.2	0	0.17
	(dots)	2,598	1,299	2,480	1,299	59	0	50
<b>Envelope C5</b>	(mm)	229	162	219	162	5	0	4.23
	(inch)	9	6.4	8.6	6.4	0.2	0	0.17
	(dots)	2,704	1,913	2,586	1,913	59	0	50
<b>Hagaki</b>	(mm)	148	100	138	100	5	0	4.23
	(inch)	5.8	3.9	5.4	3.9	0.2	0	0.17
	(dots)	1,748	1,181	1,630	1,181	59	0	50
<b>A4 Long</b>	(mm)	405	210	395	210	5	0	4.23
	(inch)	15.9	8.3	15.6	8.3	0.2	0	0.17
	(dots)	4,783	2,480	4,665	2,480	59	0	50
<b>DL Long Edge</b>	(mm)	110	220	102	220	4.23	0	6.27
	(inch)	4.3	8.7	4	8.7	0.17	0	0.25
	(dots)	1,299	2,598	1,199	2,598	50	0	74
<b>3X5</b>	(mm)	127	76.2	116.8	76.2	5.08	0	4.23
	(inch)	5	3	4.6	3	0.2	0	0.17
	(dots)	1,500	900	1,380	900	60	0	50

**Note:**

- The paper sizes indicated here should confirm to the nominal dimensions specified by JIS except B5 (ISO), B6 (ISO).
- The dot size is based on 300 dpi resolution.

Specifications are subject to change without notice.

## ■ PS3/PCL6 (PCLXL) emulation

When using PS3/PCL6 (PCLXL) emulation, the edges of the paper that cannot be printed on are shown below.

### Portrait

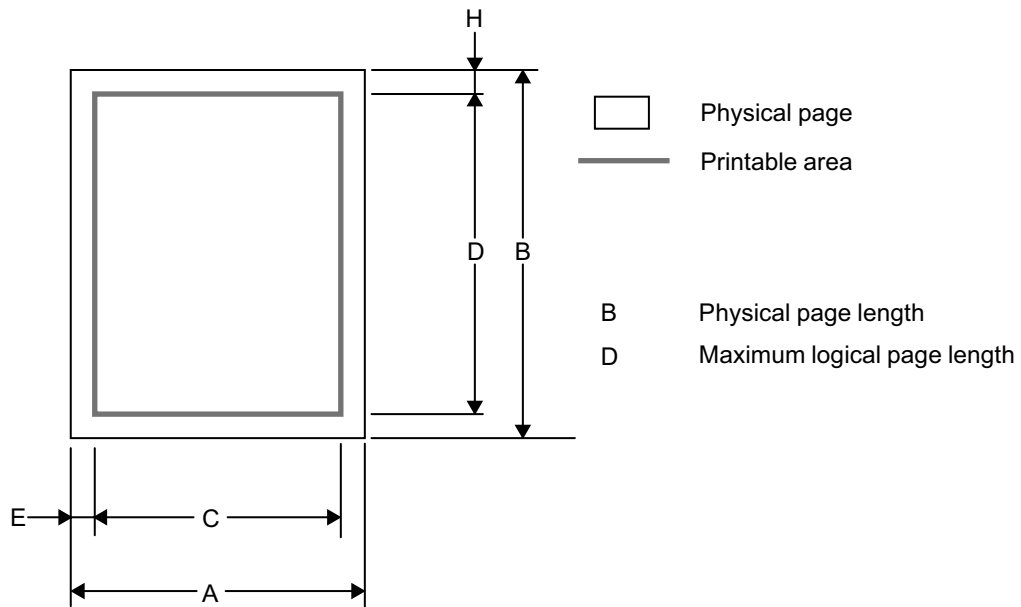

#### **Note:**

This is equivalent to the printable area for a PS driver.

Specifications are subject to change without notice.



The table below shows the printable areas when printing on Portrait for each paper size.

Size		A	B	C	D	E	H
<b>Letter</b>	(mm)	215.9	279.4	207.4	270.9	4.23	4.23
	(inch)	8.5	11	8.17	10.67	0.17	0.17
	(dots)	2,550	3,300	2,450	3,200	50	50
<b>Legal</b>	(mm)	215.9	355.6	207.4	347.1	4.23	4.23
	(inch)	8.5	14	8.17	13.67	0.17	0.17
	(dots)	2,550	4,200	2,450	4,100	50	50
<b>Folio</b>	(mm)	215.9	330.2	207.4	321.7	4.23	4.23
	(inch)	8.5	13	8.17	12.67	0.17	0.17
	(dots)	2,550	3,900	2,450	3,800	50	50
<b>Executive</b>	(mm)	184.2	266.7	175.7	258.2	4.23	4.23
	(inch)	7.25	10.5	6.92	10.17	0.17	0.17
	(dots)	2,175	3,150	2,025	3,050	50	50
<b>A4</b>	(mm)	210	297	202	288	4.23	4.23
	(inch)	8.3	11.7	7.9	11.4	0.17	0.17
	(dots)	2,480	3,507	2,380	3,407	50	50
<b>A5</b>	(mm)	148	210	140	202	4.23	4.23
	(inch)	5.8	8.3	5.5	7.9	0.17	0.17
	(dots)	1,748	2,480	1,648	2,380	50	50
<b>A5 Long Edge</b>	(mm)	210	148	202	140	4.23	4.23
	(inch)	8.3	5.8	7.9	5.5	0.17	0.17
	(dots)	2,480	1,748	2,380	1,648	50	50
<b>A6</b>	(mm)	105	148	97	140	4.23	4.23
	(inch)	4.1	5.8	3.8	5.5	0.17	0.17
	(dots)	1,240	1,748	1,140	1,648	50	50
<b>B5 (JIS)</b>	(mm)	182	257	173	248	4.23	4.23
	(inch)	7.2	10.1	6.8	9.8	0.17	0.17
	(dots)	2,148	3,030	2,048	2,930	50	50
<b>B5 (ISO)</b>	(mm)	176	250	167	241	4.23	4.23
	(inch)	6.9	9.8	6.6	9.5	0.17	0.17
	(dots)	2,078	2,952	1,978	2,852	50	50
<b>B6 (JIS)</b>	(mm)	128	182	119	173	4.23	4.23
	(inch)	5	7.2	4.7	6.8	0.17	0.17
	(dots)	1,511	2,149	1,411	2,049	50	50
<b>B6 (ISO)</b>	(mm)	125	176	117	167	4.23	4.23
	(inch)	4.9	6.9	4.6	6.6	0.17	0.17
	(dots)	1,476	2,078	1,376	1,978	50	50
<b>Envelope Monarch</b>	(mm)	98.4	190.5	89.9	182	4.23	4.23
	(inch)	3.875	7.5	3.54	7.17	0.17	0.17
	(dots)	1,162	2,250	1,062	2,150	50	50
<b>Envelope Com-10</b>	(mm)	104.7	241.3	96.3	232.8	4.23	4.23
	(inch)	4.125	9.5	3.79	9.17	0.17	0.17
	(dots)	1,237	2,850	1,037	2,750	50	50
<b>Envelope DL</b>	(mm)	110	220	102	211	4.23	4.23
	(inch)	4.3	8.7	4	8.3	0.17	0.17
	(dots)	1,299	2,598	1,199	2,498	50	50
<b>Envelope C5</b>	(mm)	162	229	154	220	4.23	4.23
	(inch)	6.4	9	6	8.7	0.17	0.17
	(dots)	1,913	2,704	1,813	2,604	50	50
<b>Hagaki</b>	(mm)	100	148	92	140	4.23	4.23
	(inch)	3.9	5.8	3.6	5.5	0.17	0.17
	(dots)	1,181	1,748	1,081	1,648	50	50
<b>A4 Long</b>	(mm)	210	405	202	396	4.23	4.23
	(inch)	8.3	15.9	7.9	15.9	0.17	0.17
	(dots)	2,480	4,783	2,380	4,683	50	50
<b>DL Long Edge</b>	(mm)	220	110	207	102	6.27	4.23
	(inch)	8.7	4.3	8.2	4	0.25	0.17
	(dots)	2,598	1,299	2,450	1,199	74	50
<b>3X5</b>	(mm)	76.2	127	67.7	118.5	4.23	4.23
	(inch)	3	5	2.67	4.67	0.17	0.17
	(dots)	900	1,500	800	1,400	50	50

**Note:**

- The paper sizes indicated here should confirm to the nominal dimensions specified by JIS except B5 (ISO), B6 (ISO).
- The dot size is based on 300 dpi resolution.

Specifications are subject to change without notice.

Landscape

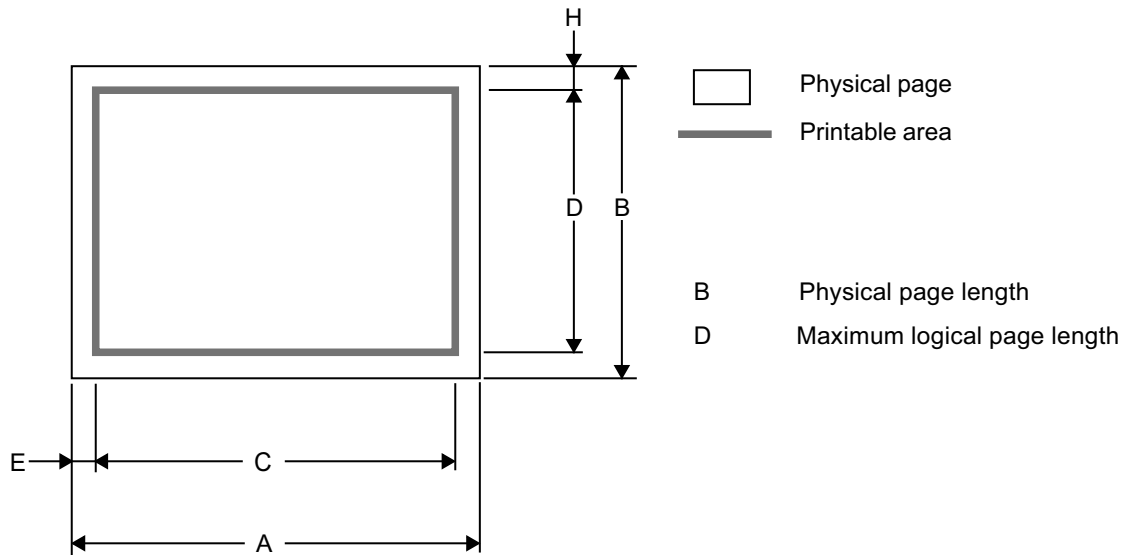

**Note:**  
This is equivalent to the printable area for a PS driver.

Specifications are subject to change without notice.

The table below shows the printable areas when printing on Landscape for each paper size.

Size		A	B	C	D	E	H
<b>Letter</b>	(mm)	279.4	215.9	270.9	207.4	4.23	4.23
	(inch)	11	8.5	10.67	8.17	0.17	0.17
	(dots)	3,300	2,550	3,200	2,450	50	50
<b>Legal</b>	(mm)	355.6	215.9	347.1	207.4	4.23	4.23
	(inch)	14	8.5	13.67	8.17	0.17	0.17
	(dots)	4,200	2,550	4,100	2,450	50	50
<b>Folio</b>	(mm)	330.2	215.9	321.7	207.4	4.23	4.23
	(inch)	13	8.5	12.67	8.17	0.17	0.17
	(dots)	3,900	2,550	3,800	2,450	50	50
<b>Executive</b>	(mm)	266.7	184.2	258.2	175.7	4.23	4.23
	(inch)	10.5	7.25	10.17	6.92	0.17	0.17
	(dots)	3,150	2,175	3,050	2,075	50	50
<b>A4</b>	(mm)	297	210	288	202	4.23	4.23
	(inch)	11.7	8.3	11.4	7.9	0.17	0.17
	(dots)	3,507	2,480	3,407	2,380	50	50
<b>A5</b>	(mm)	210	148	202	140	4.23	4.23
	(inch)	8.3	5.8	7.9	5.5	0.17	0.17
	(dots)	2,480	1,748	2,380	1,648	50	50
<b>A5 Long Edge</b>	(mm)	148	210	140	202	4.23	4.23
	(inch)	5.8	8.3	5.5	7.9	0.17	0.17
	(dots)	1,748	2,480	1,648	2,380	50	50
<b>A6</b>	(mm)	148	105	140	97	4.23	4.23
	(inch)	5.8	4.1	5.5	3.8	0.17	0.17
	(dots)	1,748	1,240	1,648	1,140	50	50
<b>B5 (JIS)</b>	(mm)	257	182	248	173	4.23	4.23
	(inch)	10.1	7.2	9.8	6.8	0.17	0.17
	(dots)	3,030	2,148	2,930	2,048	50	50
<b>B5 (ISO)</b>	(mm)	250	176	241	167	4.23	4.23
	(inch)	9.8	6.9	9.5	6.6	0.17	0.17
	(dots)	2,952	2,078	2,852	1,978	50	50
<b>B6 (JIS)</b>	(mm)	182	128	173	119	4.23	4.23
	(inch)	7.2	5	6.8	4.7	0.17	0.17
	(dots)	2,149	1,511	2,049	1,411	50	50
<b>B6 (ISO)</b>	(mm)	176	125	167	117	4.23	4.23
	(inch)	6.9	4.9	6.6	4.6	0.17	0.17
	(dots)	2,078	1,476	1,978	1,376	50	50
<b>Envelope Monarch</b>	(mm)	190.5	98.4	182	89.9	4.23	4.23
	(inch)	7.5	3.875	7.17	3.54	0.17	0.17
	(dots)	2,250	1,162	2,150	1,062	50	50
<b>Envelope Com-10</b>	(mm)	241.3	104.7	232.8	96.3	4.23	4.23
	(inch)	9.5	4.125	9.17	3.79	0.17	0.17
	(dots)	2,850	1,237	2,750	1,137	50	50
<b>Envelope DL</b>	(mm)	220	110	211	102	4.23	4.23
	(inch)	8.7	4.3	8.3	4	0.17	0.17
	(dots)	2,598	1,299	2,498	1,199	50	50
<b>Envelope C5</b>	(mm)	229	162	220	154	4.23	4.23
	(inch)	9	6.4	8.7	6	0.17	0.17
	(dots)	2,704	1,913	2,604	1,813	50	50
<b>Hagaki</b>	(mm)	148	100	140	92	4.23	4.23
	(inch)	5.8	3.9	5.5	3.6	0.17	0.17
	(dots)	1,748	1,181	1,648	1,081	50	50
<b>A4 Long</b>	(mm)	405	210	396	202	4.23	4.23
	(inch)	15.9	8.3	15.6	7.9	0.17	0.17
	(dots)	4,783	2,480	4,683	2,380	50	50
<b>DL Long Edge</b>	(mm)	110	220	102	207	4.23	6.27
	(inch)	4.3	8.7	4	8.2	0.17	0.25
	(dots)	1,299	2,598	1,199	2,450	50	74
<b>3X5</b>	(mm)	127	76.2	118.5	67.7	4.23	4.23
	(inch)	5	3	4.67	2.67	0.17	0.17
	(dots)	1,500	900	1,400	800	50	50

**Note:**

- The paper sizes indicated here should confirm to the nominal dimensions specified by JIS except B5 (ISO), B6 (ISO).
- The dot size is based on 300 dpi resolution.

Specifications are subject to change without notice.

## 2.7 Print Speeds with Various Settings

Print speed is up to 16 ppm for A4 size and 17 ppm for Letter size when loading A4 or Letter size paper from the paper tray in the plain paper mode.

Actual print speed varies depending on the media type or paper size as shown in the tables below:

### <A4/Letter size>

Media type setting	Print speed (for all models)
Plain paper, Recycled paper	16/17 ppm
Thick paper, Envelope, Envelope thin, Label	8 ppm
Thicker paper, Bond paper, Envelope thick	4 ppm

### <Smaller size than A4 or Letter>

Media type setting	Print speed (for all models)
Plain paper, Recycled paper	17 ppm
Thick paper, Envelope, Envelope thin, Label	8 ppm
Thicker paper, Bond paper, Envelope thick	4 ppm

**Note:**

The actual print speed may vary according to conditions, such as paper size and paper tray.

Specifications are subject to change without notice.

# **CHAPTER 2**

## **THEORY OF OPERATION**

# CHAPTER 2

## THEORY OF OPERATION

This chapter gives an overview of the printing mechanisms as well as the sensors, actuators and control electronics. It aids in understanding the basic principles of operation as well as locating defects for troubleshooting.

### CONTENTS

<b>1. GENERAL BLOCK DIAGRAM .....</b>	<b>2-1</b>
<b>2. ELECTRONICS GENERAL BLOCK DIAGRAM.....</b>	<b>2-2</b>
<b>3. MECHANICS .....</b>	<b>2-3</b>
3.1 Cross-section Drawing .....	2-3
3.2 Paper Feeding .....	2-4
3.2.1 Plate-up function of the paper tray .....	2-5
3.2.2 Paper supply .....	2-6
3.2.3 Paper registration .....	2-7
3.2.4 Paper eject .....	2-8
3.2.5 Paper supply from manual feed slot and paper eject from back.....	2-9
3.3 Toner Cartridge .....	2-10
3.3.1 Type of toner cartridge.....	2-10
3.3.2 Life of toner cartridge.....	2-10
3.3.3 Method of detecting toner life .....	2-11
3.3.4 Relationship between toner amount and life of toner cartridge in number of rotations of develop roller .....	2-11
3.3.5 New toner detection.....	2-13
3.3.6 Method of counting the number of toner replacements .....	2-15
3.4 Principle of Color Overlapping.....	2-16
3.5 Basic Printing Principle .....	2-17
3.5.1 Charging .....	2-18
3.5.2 Exposure .....	2-19
3.5.3 Development .....	2-20
3.5.4 Transfer .....	2-21
3.5.5 Fusing.....	2-22
3.5.6 Toner cleaning .....	2-23
3.6 Location of Sensors .....	2-24
3.7 Adjustment of Color Registration.....	2-28
3.7.1 Color registration error in sub/main scanning direction .....	2-28
3.8 Adjustment of Color Density .....	2-28

# 1. GENERAL BLOCK DIAGRAM

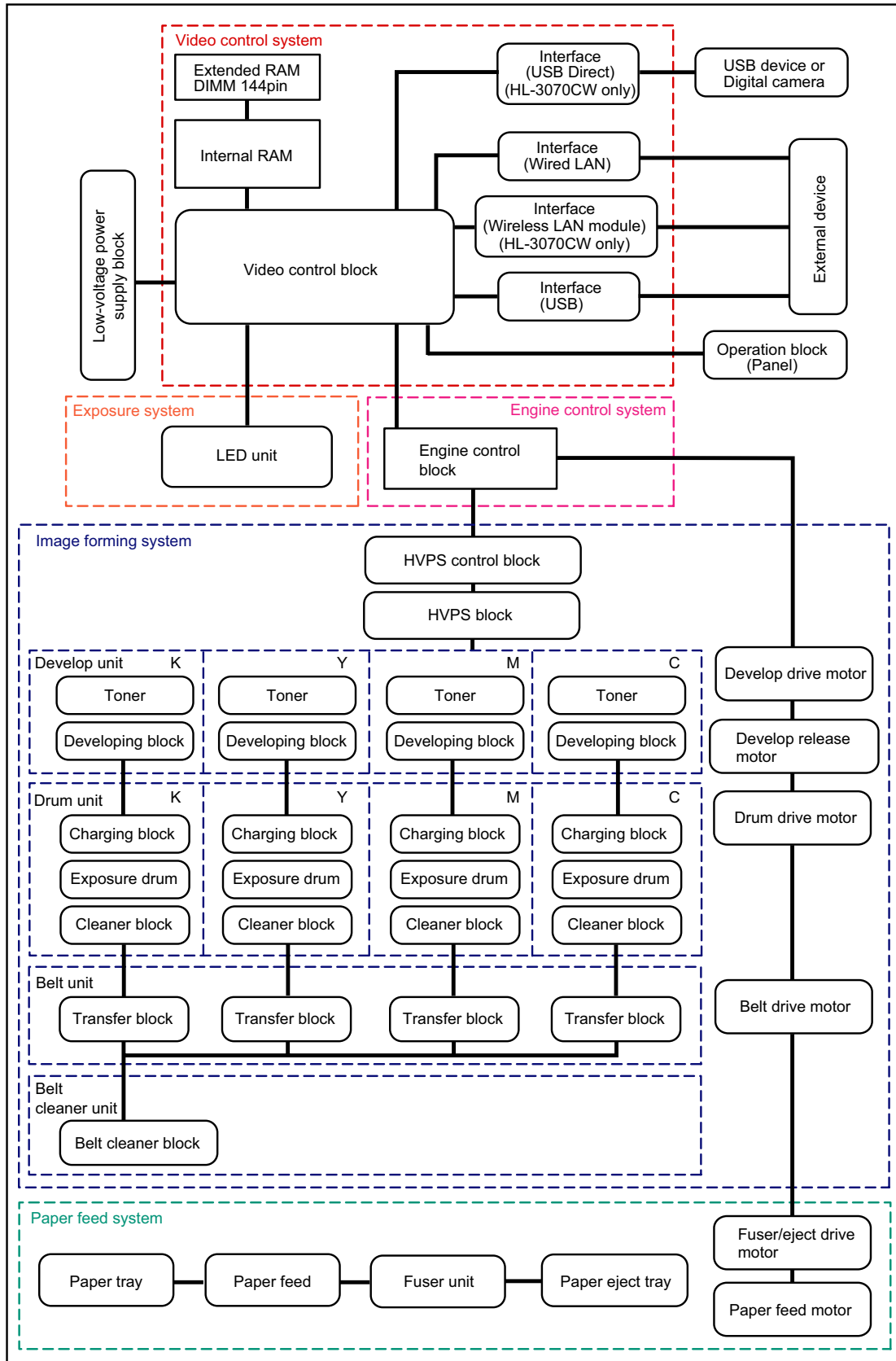

Fig. 2-1

## 2. ELECTRONICS GENERAL BLOCK DIAGRAM

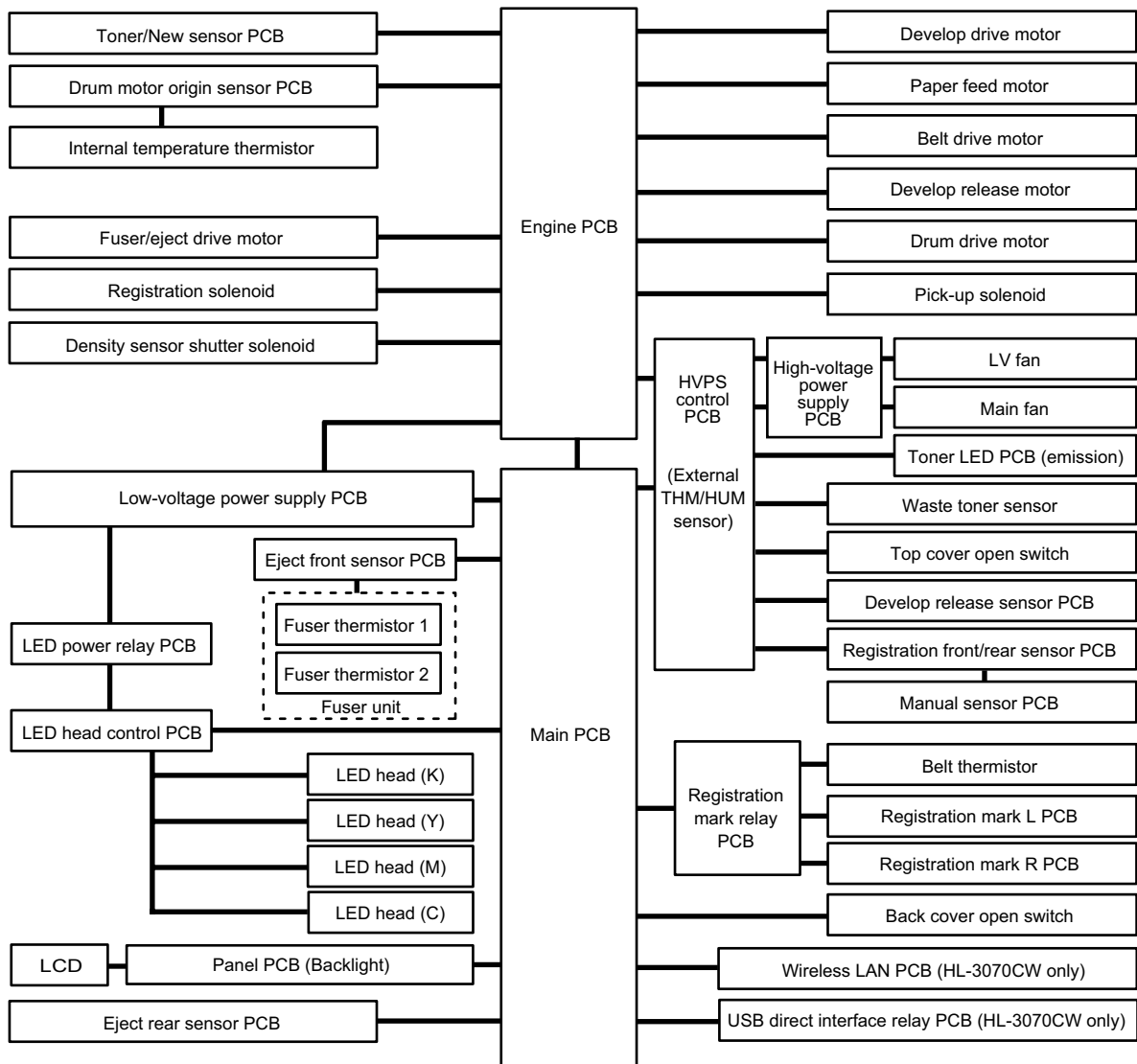

Fig. 2-2



# 3. MECHANICS

## 3.1 Cross-section Drawing

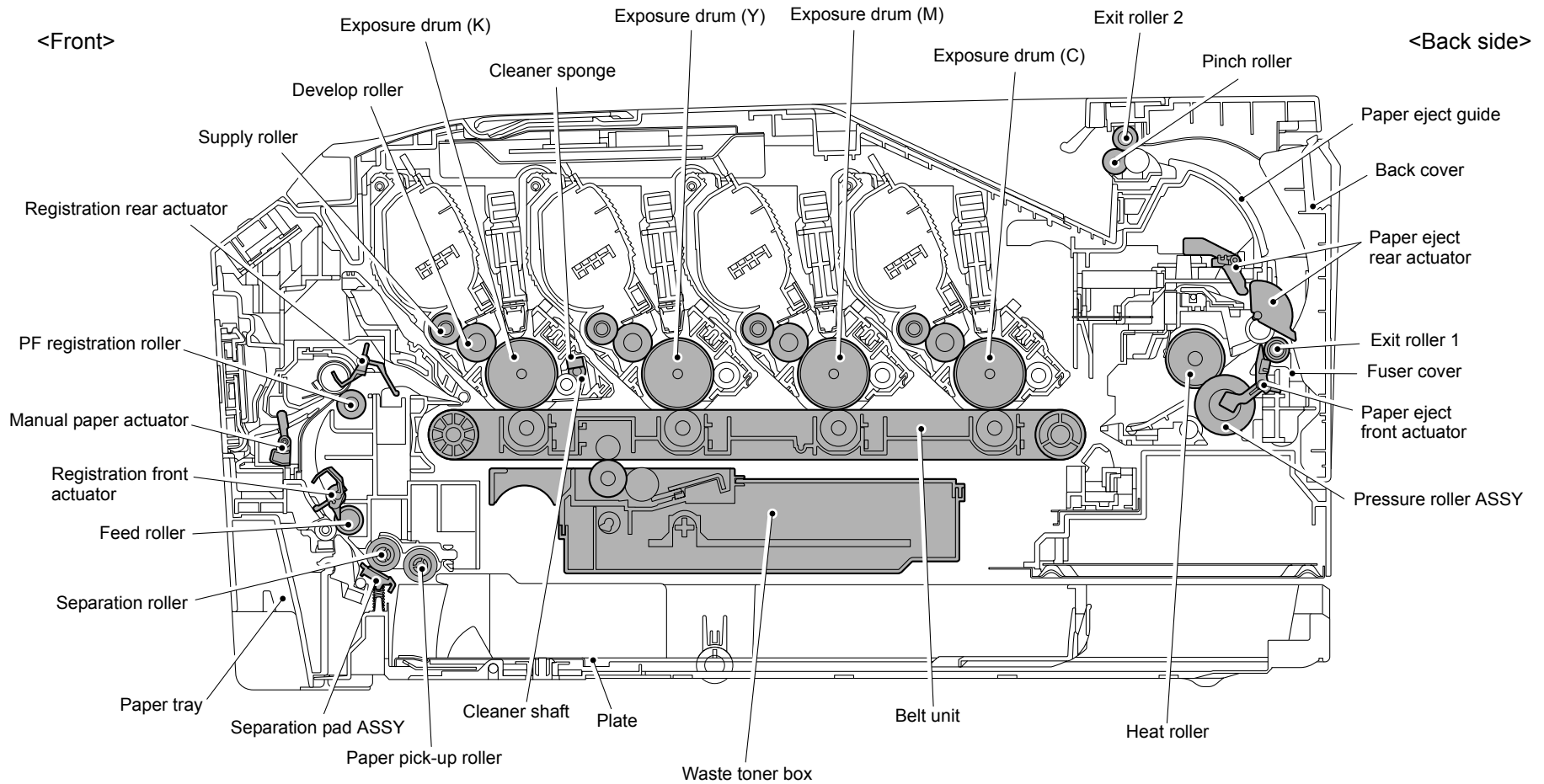

Fig. 2-3

# 3.2 Paper Feeding

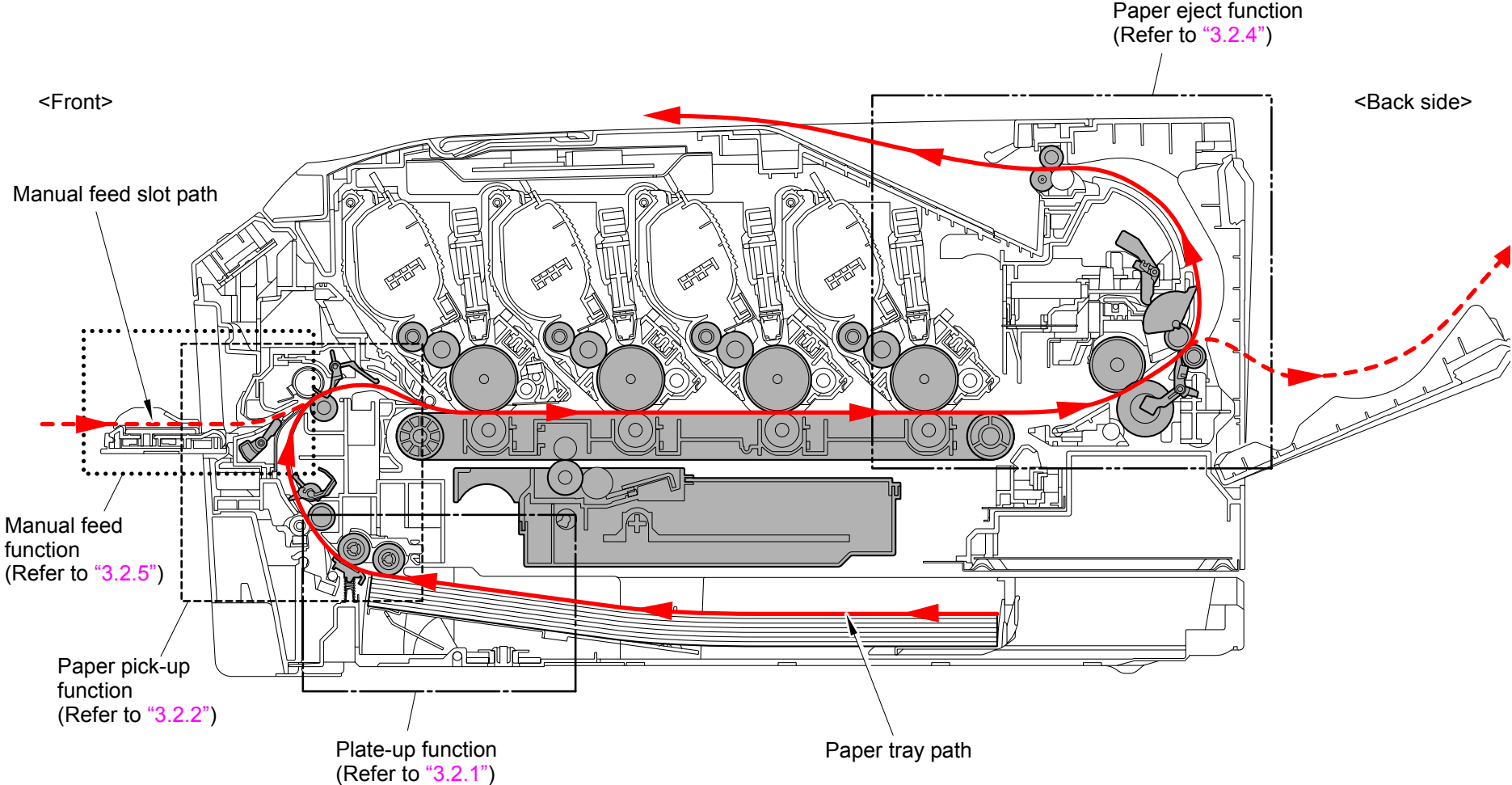

Fig. 2-4

### 3.2.1 Plate-up function of the paper tray

The plate of the paper tray is pushed up by the force exerted by the motor not by springs so as to keep pressure to the paper pick-up roller and enhance paper-feeding performance irrespective of the quantity of papers remaining in the tray.

At the time of inserting the paper tray into the main body of the product, the plate is kept lowered. When the paper feed motor is operated under such condition, a driving force is transmitted to the lift gear Z36M75 by way of several gears. The force is also transmitted to the plate-up plate to push the plate.

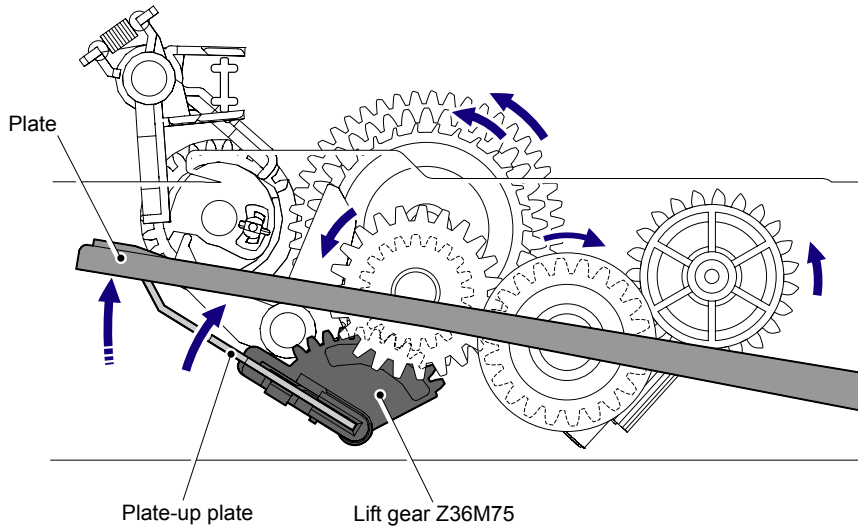

Fig. 2-5

When the plate is pushed up, the lift arm goes down and the hook B is released. The P/P gear 26 sector off the hook B rotates to push down the rib of the hook A. Subsequently, the ratchet of the hook A for the planetary clutch ASSY deviates from the gear and the plate-up plate stops its push-up function.

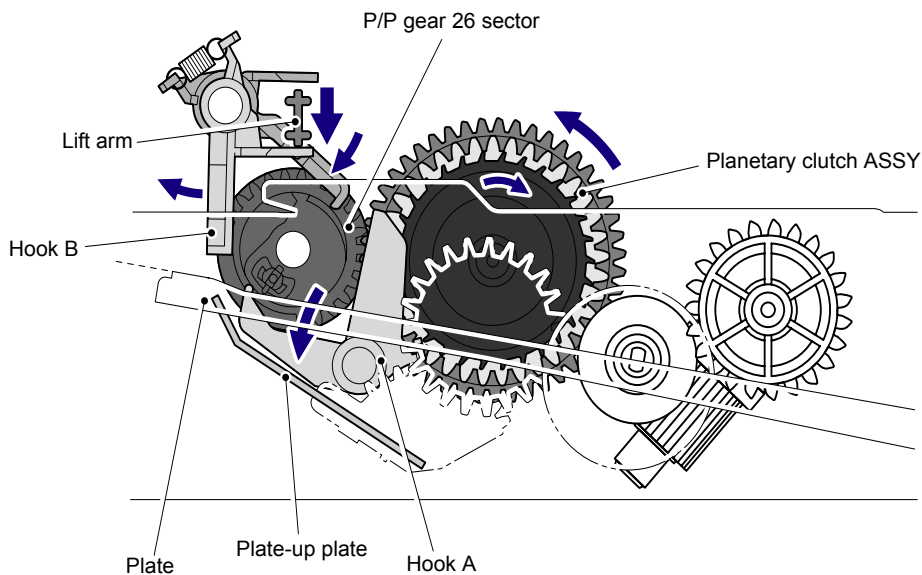

Fig. 2-6

The plate returns to the original position when the paper tray is taken out from the main body of the product, and it repeats the aforementioned operation from the beginning when the paper tray is inserted into the main body of the product.

### 3.2.2 Paper supply

When the paper pick-up solenoid is turned ON, the power of the paper feed motor rotates the paper pick-up roller, and it picks up a few sheets or one sheet of paper from the top of the sheets in the paper tray every time it is rotated and feeds it to the separation roller. Subsequently, stacks of paper are caught between the separation roller and separation pad ASSY, they are then separated into single sheets.

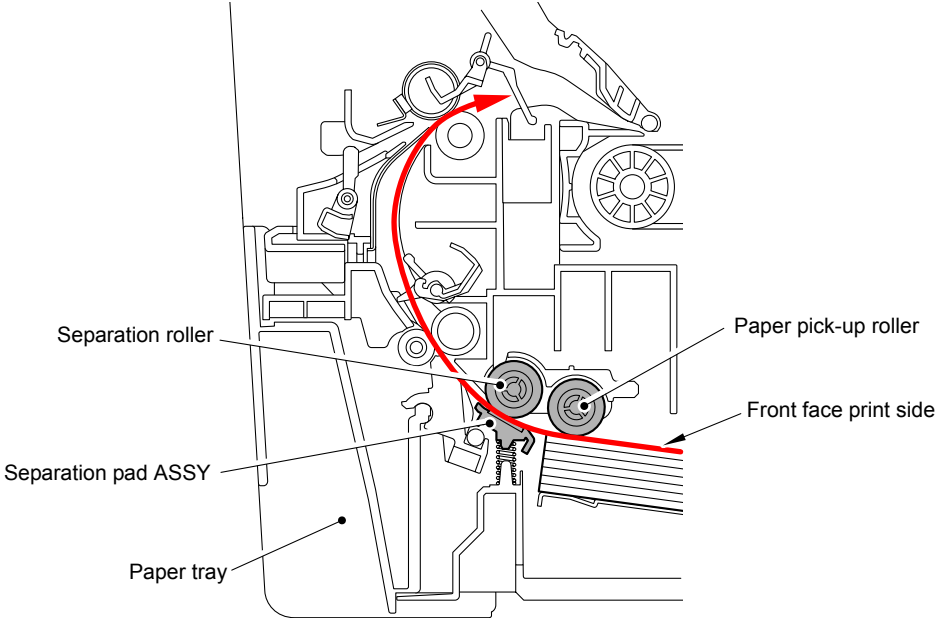

Fig. 2-7

### 3.2.3 Paper registration

Passing of each sheet of paper which is separated by the separation roller is detected by the registration front actuator. Then, the paper is fed further for a certain time, and its front edge hits the stopped PF registration roller so that the paper skew is corrected. After such correction, the registration solenoid is turned OFF, the power of the paper feed motor rotates the PF registration roller, and the paper is fed to the belt unit. The fed paper is fed to the delivery unit by the belt unit.

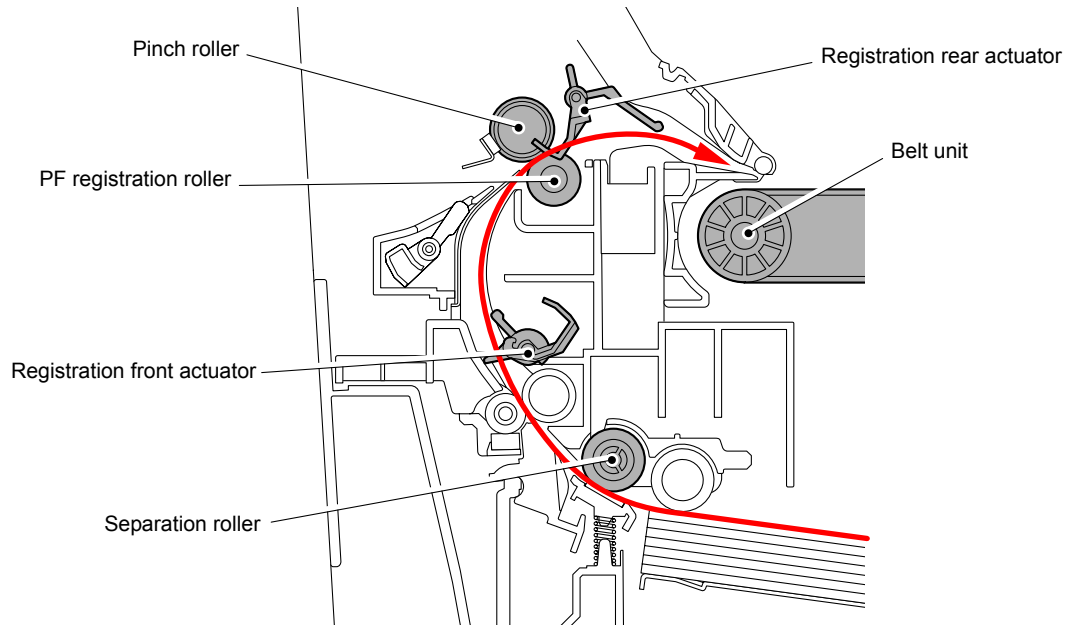

Fig. 2-8

#### <Operation of actuators>

- Registration front actuator detects the passage of paper and the trailing edge of paper.
- Registration rear actuator detects the timing when the leading edge of the paper passes through the PF registration roller to adjust the starting position for writing on the paper.
- When a paper jam occurs, both actuators will provide information to identify the location where the jam occurred.

### 3.2.4 Paper eject

Drive of the fuser/eject drive motor rotates the heat roller and pressure roller of the fuser unit, and toner on paper is fused as the paper is being fed. Paper moves along the paper eject guide and is ejected into the output tray from the exit roller 2 with its print side down.

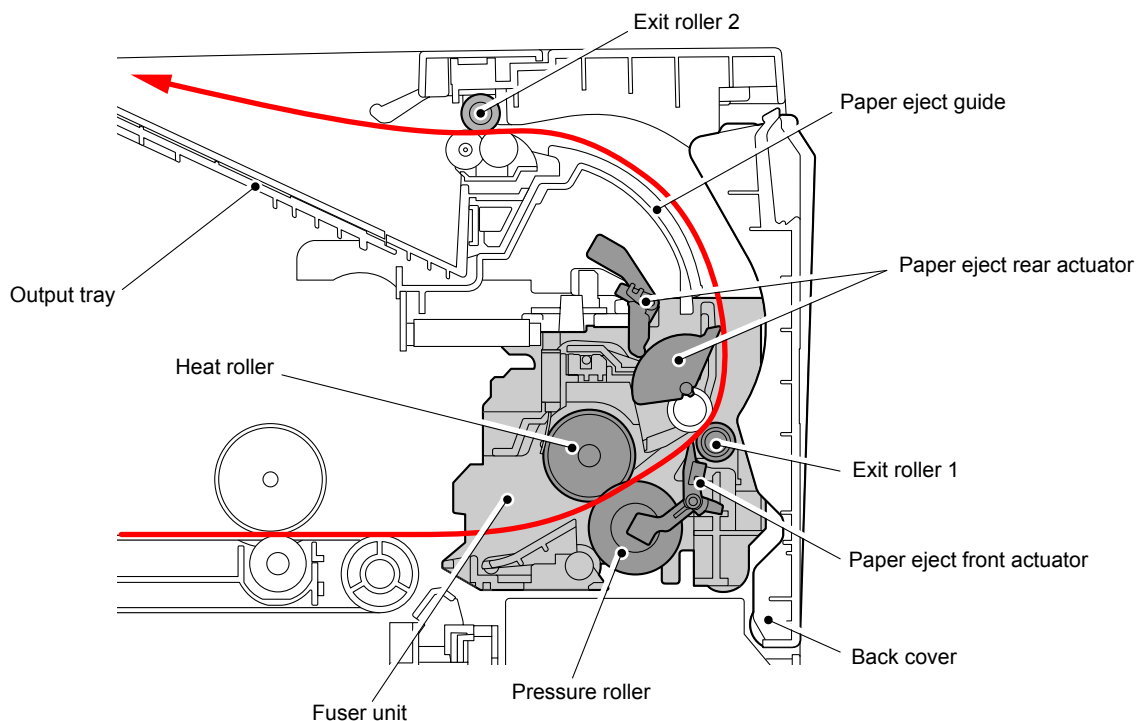

Fig. 2-9

**Memo:**

When a paper jam is detected near the paper eject front actuator and paper eject rear actuator, the paper feed motor is revolved in the reverse direction to move the gears out of engagement. The heat roller become free, allowing any paper jam to be cleared.

**<Operation of actuators>**

- The paper eject front actuator detects that the paper passes through the heat roller to detect that the paper does not wind around the heat roller.
- The paper eject rear actuator detects that the paper passes through the fuser unit to detect that a paper jam does not occur between the heat roller and exit roller 1.

### 3.2.5 Paper supply from manual feed slot and paper eject from back

When making print from the manual feed slot, set papers on it with the print side up. A sheet of paper which is inserted from the manual feed slot one by one presses the manual paper actuator, and consequently the actuator detects that there is a sheet of paper. When the manual paper actuator is turned ON, pick-up from the manual feed slot is given priority. Power of the paper feed motor rotates the PF registration roller, and a sheet of paper is picked up. When making print while the back cover is open, a printed sheet is ejected from the back with its print side up.

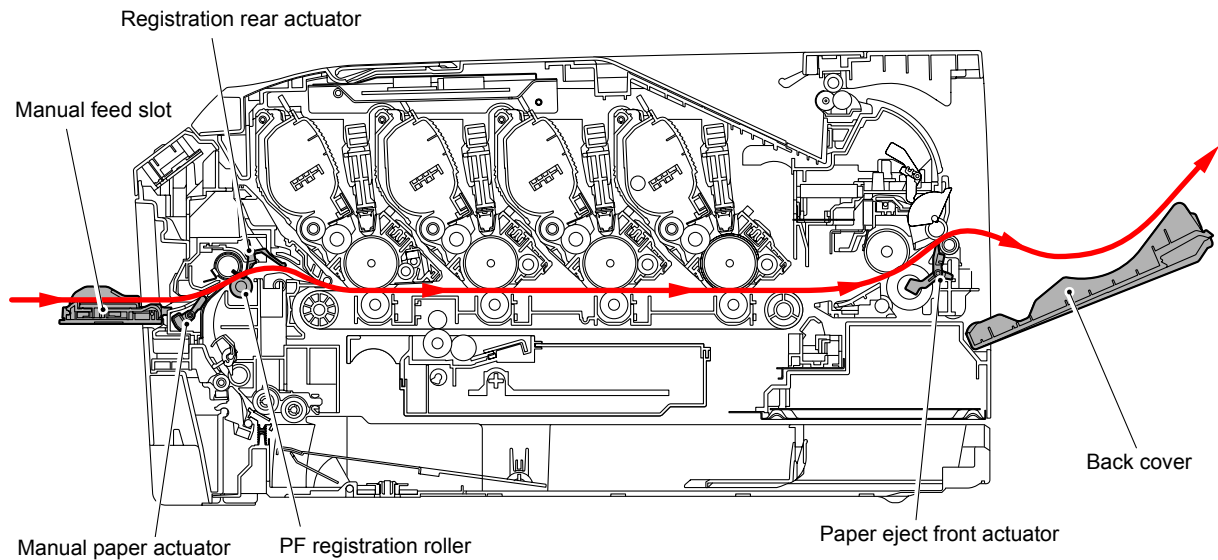

Fig. 2-10

## 3.3 Toner Cartridge

### 3.3.1 Type of toner cartridge

This product has four types of toner cartridges, K (black), Y (yellow), M (magenta), and C (cyan), and each toner cartridge has starter toner cartridge and standard toner cartridge. The toner cartridges supplied with the product are starter toner cartridges, and the toner cartridges which are sold as consumable parts are standard toner cartridges. There is a difference in the capacity and inner shape between K and Y/M/C. In addition, the location to install each cartridge is fixed depending on the colors.

### 3.3.2 Life of toner cartridge

In the following two cases, this product considers that the toner cartridge reaches its life end and stops printing thereafter.

- When the remaining toner powder becomes insufficient for printing
- When the number of accumulated rotations of the develop roller reaches a specified value, and it is considered that the roller cannot maintain sufficient performance

(1) Number of printable pages by a single toner cartridge

When making prints in accordance with ISO/IEC 19798, the number of printable pages by a single toner cartridge is shown in the table below:

Toner cartridge		Number of printable pages
Starter	Black	1,000 pages
	Yellow, Magenta, Cyan	1,000 pages
Standard	Black	2,200 pages
	Yellow, Magenta, Cyan	1,400 pages

(2) Upper limit of number of rotations of develop roller

The upper limit of the number of rotations of the develop roller is shown in the table below:

Toner cartridge		Upper limit of rotations of the develop roller
Starter	Black	26,880 rotations
	Yellow, Magenta, Cyan	26,880 rotations
Standard	Black	57,600 rotations
	Yellow, Magenta, Cyan	38,400 rotations

The graph given in the [next page](#) shows the overview of change in the number of printable pages in the case of making prints on A4-size paper.

**Memo:**

- The number of rotation of the developer roller per page is as follows.

	Color	Monochrome
Number of developer roller rotations for the first page printed	38.4 rotations	35.1 rotations
Number of developer roller rotations for the second page and after (in the case of continuous printing)	14.6 rotations	14.5 rotations

- Number of idling rotation when the printer is turned ON=110.4 rotations
- Number of rotations upon warm-up operation=11.0 rotations
- Number of rotations upon color registration adjustment=42.7 rotations
- Number of rotations upon color density adjustment=56.7 rotations

**Note:**

The numeral values provided in this page are as of July 2009. These values are subject to change without prior notice.



### 3.3.3 Method of detecting toner life

This product detects the life of the toner cartridges using the following two means.

#### ■ Detection by the toner sensor

This product has a function to detect the remaining toner by checking the level at which toner in a cartridge interrupts light using a transmissive light sensor.

#### ■ Detection by means of rotation rates of the develop roller reached its upper limit

This product has a function to stop the operation even if toner remains when the number of rotation reaches the upper limit before the develop roller is worn out and becomes unusable. When toner reaches its life, this product notifies the users about it by displaying a message to that effect on the LCD. There are two messages to indicate toner reaches its life: "Toner Low" and "Replace Toner." While "Toner Low" is displayed on the LCD when the toner sensor detects a certain amount of toner is used, "Replace Toner" is displayed on the LCD when the toner sensor detects that usable toner in a toner cartridge is used up or when the number of rotations of the develop roller reaches its life.

When "Replace Toner" is displayed on the LCD, no print can be made on this machine until the toner cartridge in question is replaced with a new one.

### 3.3.4 Relationship between toner amount and life of toner cartridge in number of rotations of develop roller

The number of printable pages by a single toner cartridge and upper limit of the number of rotations of the develop roller are provided in the tables in the previous page. When printing low-duty documents, however, there is a possibility that the number of rotations of the develop roller reaches the upper limit, and "Replace Toner" is displayed before toner runs out.

#### ■ Relationship between printable pages of the toner cartridge and remaining toner

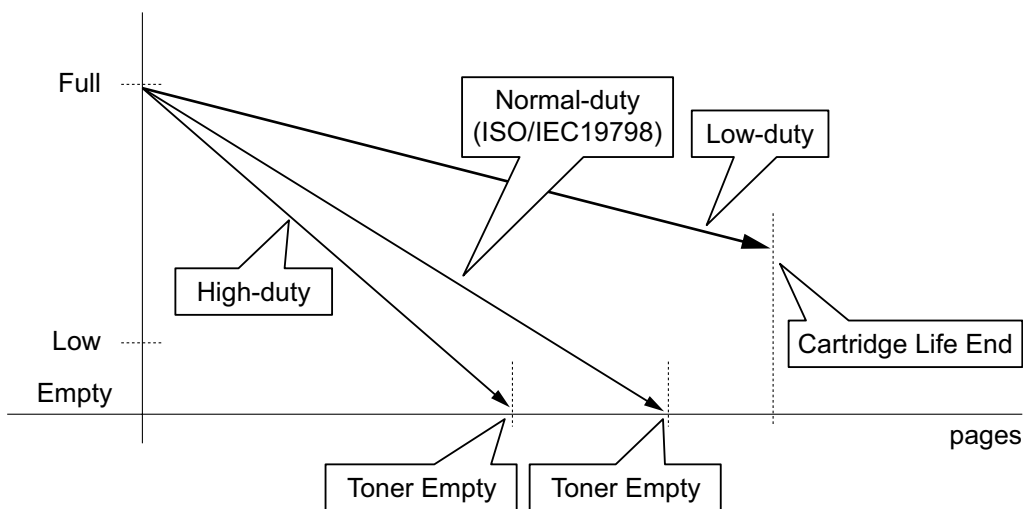

#### **Memo:**

When the number of rotations of the develop roller reaches the upper limit, "Replace Toner" is displayed even if toner remains.

### <Life of toner cartridge>

The life of the toner cartridge varies according to the average number of print pages per job. (See the table below.) The number of printable pages is larger when making continuous prints in one job because deterioration of the develop roller is low.

Relationship between average print page per 1 job and life of toner cartridges

Average print page (page/job)	1	2	3	4	5	6	7	8
Cartridge life (Standard-K)	1,500	2,174	2,556	2,803	2,975	3,102	3,200	3,277
Cartridge life (Standard-YMC)	1,000	1,449	1,704	1,869	1,983	2,068	2,133	2,185
Cartridge life (Starter-KYMC)	700	1,014	1,193	1,308	1,388	1,448	1,493	1,529

The develop roller also rotates for the warm-up operation, color registration adjustment operation, and developing bias adjustment operation when the power is turned ON and when the cover is opened or closed. Therefore, when these operations are frequently performed, the life of toner cartridges is shortened. (The table below shows the worst case in which the warm-up operation, color registration adjustment, and developing bias adjustment are performed when the power is turned ON.)

Life of the toner cartridges in the case that the power is turned OFF/ON for every print job, and color registration adjustment and developing bias adjustment are performed

Average print page (page/job)	1	2	3	4	5	6	7	8
Cartridge life (Standard-K)	232	438	623	789	939	1,076	1,201	1,315
Cartridge life (Standard-YMC)	155	292	415	526	626	717	800	877
Cartridge life (Starter-KYMC)	108	205	291	368	438	502	560	614

#### **Memo:**

- This product prohibits the print operation while any of the toner cartridges is not mounted or when "Replace Toner" is displayed. In other words, neither monochrome printing without a color toner cartridge nor color printing without a black toner cartridge is available.
- This product does not have a function to identify colors of the color toner cartridges.

#### **Note:**

The numeral values provided in this page are as of July 2009. These values are subject to change without prior notice.

### 3.3.5 New toner detection

When a toner cartridge is replaced and a new toner cartridge is mounted, there is a need to reset the develop bias voltage value (refer to [next page](#)) to the initial value and to reset prohibition of the print operation by clearing the display of "Toner Low" or "Replace Toner." The old and new toner cartridges can be identified using the new toner detection mechanism shown below.

#### ■ New toner detection mechanism

When a new toner cartridge is mounted and the develop drive motor starts rotating, rotation is conveyed to the reset gear via some other gears. Consequently, the rib on the reset gear presses the reset upper lever, it turns ON the new toner sensor, and it is detected that a new toner cartridge is mounted. If the develop drive motor further rotates, the rib on the reset gear is disengaged from the reset upper lever, and the new toner sensor is turned OFF.

#### <For Standard toner cartridge>

Drive of the develop drive motor rotates the reset gear, and the rib on the reset gear presses the reset upper lever. Consequently, the new toner sensor turns ON, and it is detected that a new toner cartridge is mounted.

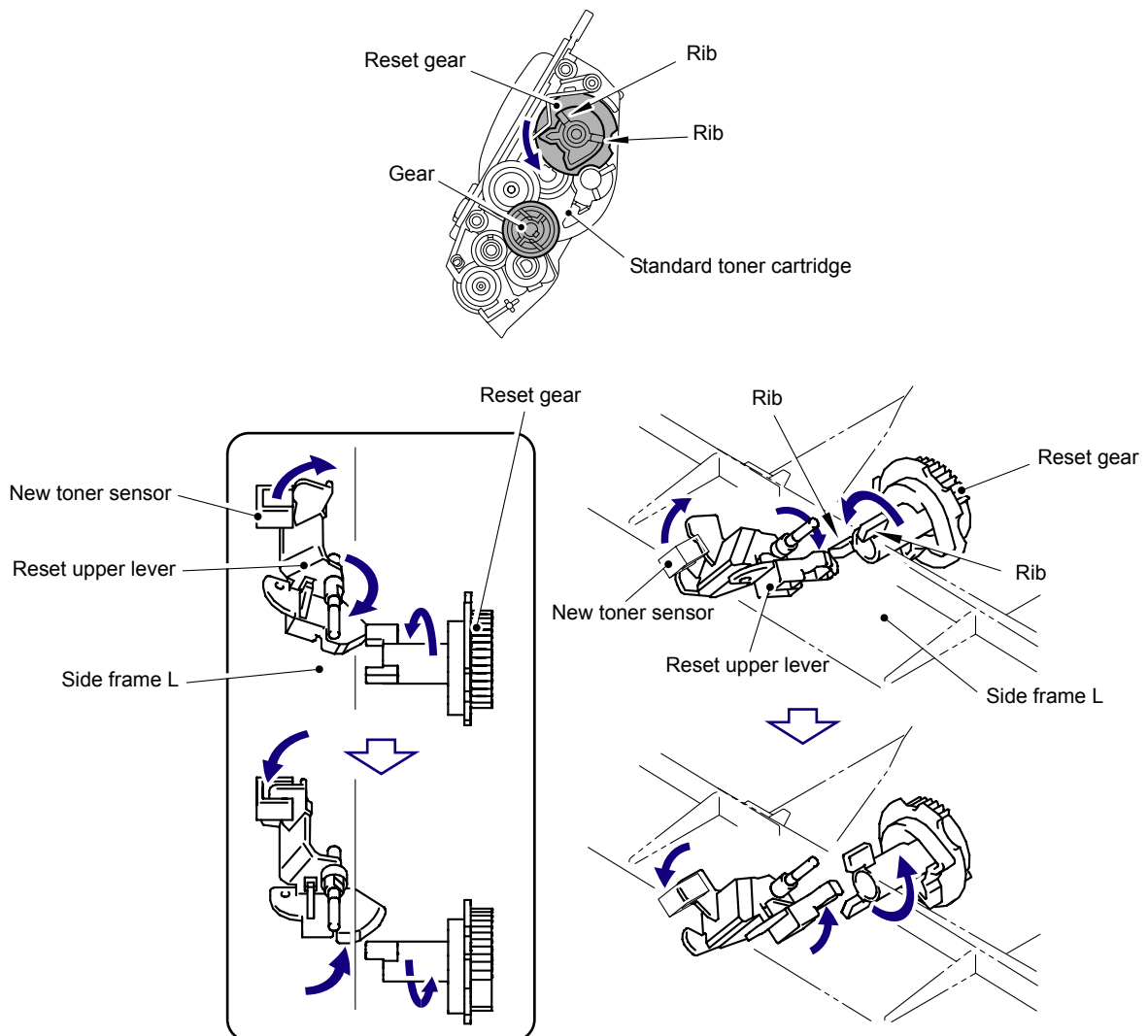

Fig. 2-11

#### <For Starter toner cartridge>

It is assumed that the starter toner cartridge is mounted when the main unit is turned ON for the first time after the product is shipped out. The reset gear is not mounted.

## ■ Developing bias voltage

Toner in use tends to have a low print density at the beginning of its use, but the density gradually becomes higher after a certain period of use if the bias voltage is kept at a certain level during development.

The properties of the toner is controlled by means of the developing bias voltage. The values are varied according to counts of the amount of toner used immediately after a toner cartridge is changed so that excellent print quality of even contrast can be obtained constantly from the printing start time to the stop time.

In addition, the developing bias voltage of each toner cartridge is periodically corrected so as to eliminate variation in the density of the four colors.

When the new toner detection mechanism detects the change to a new toner cartridge, the developing bias voltage is reset.

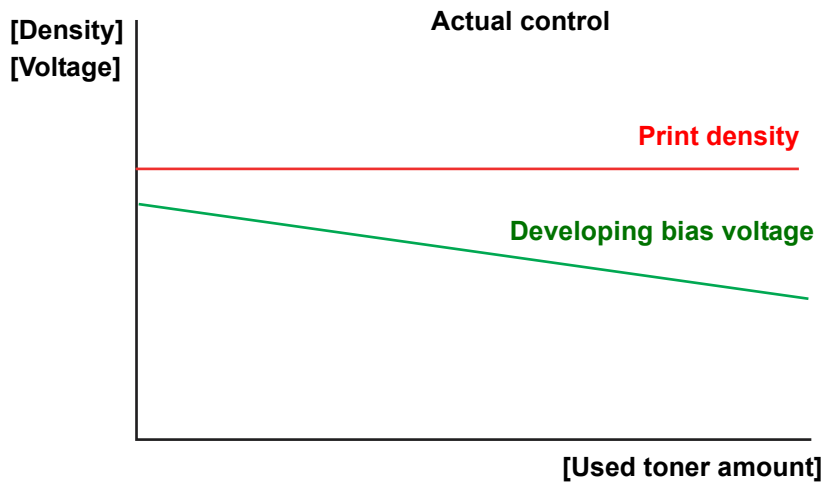

Fig. 2-12

### Note:

If a toner cartridge in use is replaced to a cartridge which has previously been in use before reaching a toner life, the developing bias voltage will become incorrect and the density will be changed, and consequently it may cause print failures. Toner cartridges being used must not be replaced with other ones.

### 3.3.6 Method of counting the number of toner replacements

This machine keeps the number of times that the toner cartridges are replaced and the page counters to learn the usage of the machine. These counters will not be deleted even if the power is turned OFF. The following tables explain the method of counting the counter values when the toner cartridges are replaced.

#### <When a brand-new toner cartridge (unused) is inserted after “Replace Toner” is displayed>

Corresponding counter, Setting value	Operation
Counter of toner cartridge changes	+ 1
Page counter for each toner cartridge	Reset (0)
Coverage for each toner cartridge	Reset (0)
Developing bias voltage	Reset (Initial setting)

#### <When a toner cartridge which is not brand-new is inserted after “Replace Toner” is displayed by toner sensor detection<sup>\*1</sup>>

Corresponding counter, Setting value	Operation
Counter of toner cartridge changes	No count up
Page counter for each toner cartridge	Continued
Coverage for each toner cartridge	Continued
Developing bias voltage	Reset (Initial setting) <sup>*2</sup>

<sup>\*1</sup> Excluding a toner cartridge in use in which there is a little toner remained.

<sup>\*2</sup> The developing bias voltage is reset to the initial setting once when a toner cartridge which is not brand-new is inserted. After resetting, the developing bias voltage correction is performed so that the developing bias voltage is corrected according to the amount of toner.

**Note:**

While the parameters explained above are separately controlled for 4 color toners, the same counting method is applied.

### 3.4 Principle of Color Overlapping

The human eye distinguishes one color from others by receiving light's three primary colors (Red, Green, Blue). When monochrome lights are received, each color can be sensed. However, when two-color lights, red (R) and green (G), are received, they are recognized as "yellow"; when three-color lights, red (R), green (G) and blue (B), are received, they are recognized as "white". The fineness of coloration is perceived according to the nature of light.

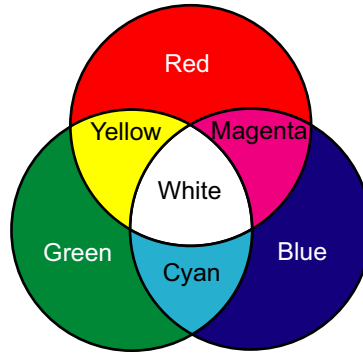
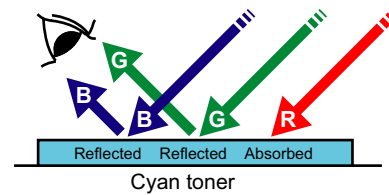

Fig. 2-13

For printed colors, the human eye can perceive them as various colors by distinguishing each color light reflected off the surface of a sheet of paper.

- (1) Green+Blue

"Cyan" absorbs red (R) light only among the three-color lights and reflects green (G) and blue (B) lights, and consequently the light is identified as "Cyan."



- (2) Red+Blue

"Magenta" absorbs green (G) light only among the three-color lights and reflects red (R) and blue (B) lights, and consequently the light is identified as "Magenta."

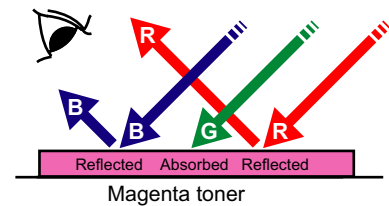

- (3) Blue

If cyan and magenta are mixed, cyan absorbs red (R) light and magenta absorbs green (G) light, and only blue (B) light is reflected. The light is identified as "blue."

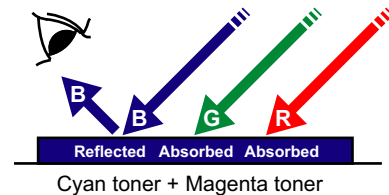

Fig. 2-14

Theoretically, if cyan, magenta and yellow are mixed, all the colors are not reflected and black can be shown. However, a black mix is difficult to produce, and black is shown using blackcolor paint for practical purposes. Using such a principle, color-absorbing paints are mixed to allow many colors to be shown on the surface of a sheet of paper.

### 3.5 Basic Printing Principle

The printing process consists broadly of 6 processes: Charging, Exposure, Development, Transfer, Fusing and Cleaning.

**<Printing process>**

- (1) Charging: The surface of the drum is electrically charged (Primary Charge).
  - (2) Exposure: A printed image is formed on the surface of the drum by applying LED beam (Electrostatic Latent Image).
  - (3) Development: Toner is adhered to the surface of the drum (Visible Image).
  - (4) Transfer: The toner on the surface of the exposure drum is transferred to the paper.
  - (5) Fusing: The transferred toner is fused on to the paper.
  - (6) Cleaning: Toner remaining on the exposure drum and belt unit is removed for recovery.
- After these processes, the image is printed on the paper.

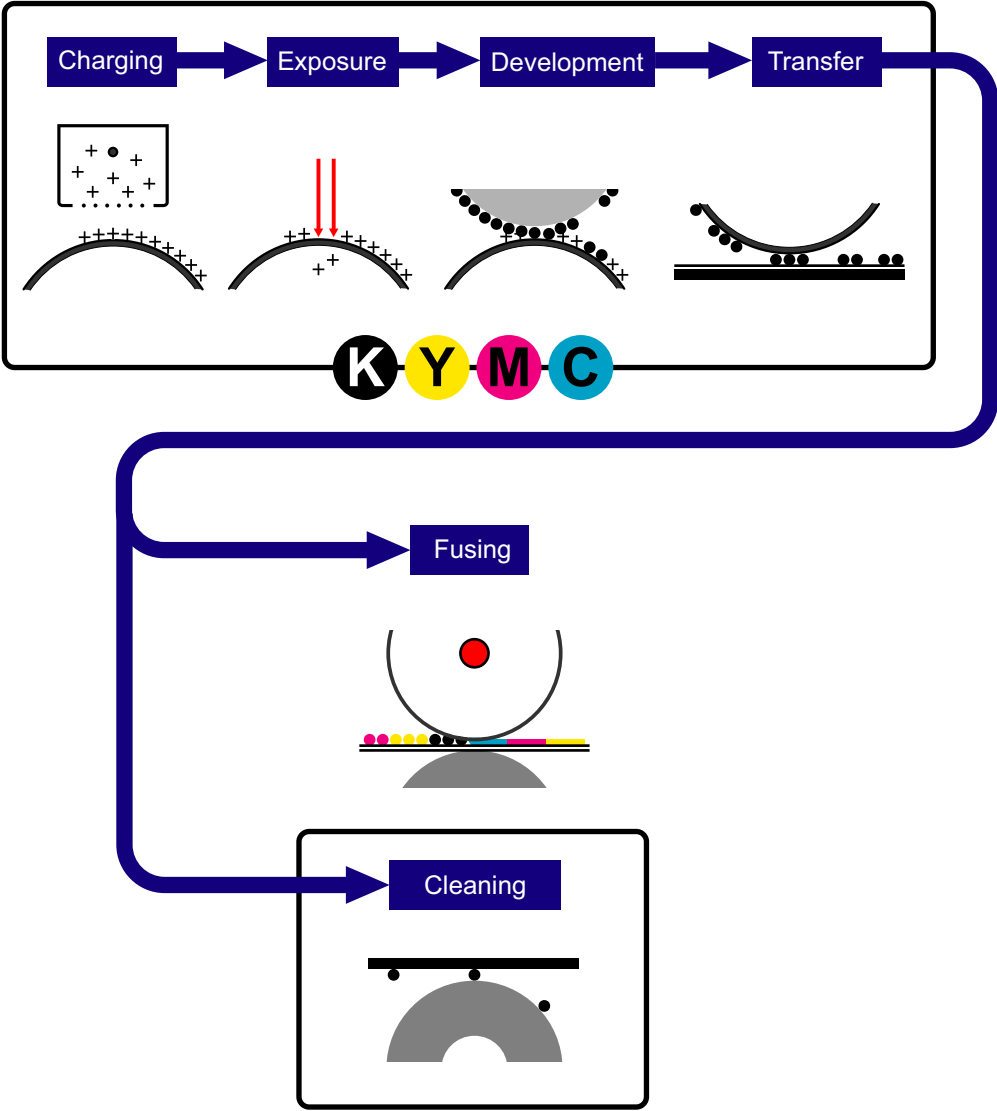

Fig. 2-15

### 3.5.1 Charging

The exposure drum needs to be evenly electrified to coat toner beautifully on the exposure drum. Ions are produced by supplying high-voltage power to the corona wire. The flow of the ion charge is controlled by the constant voltage of the grid approximately 700 V and electrified the exposure drum surface evenly.

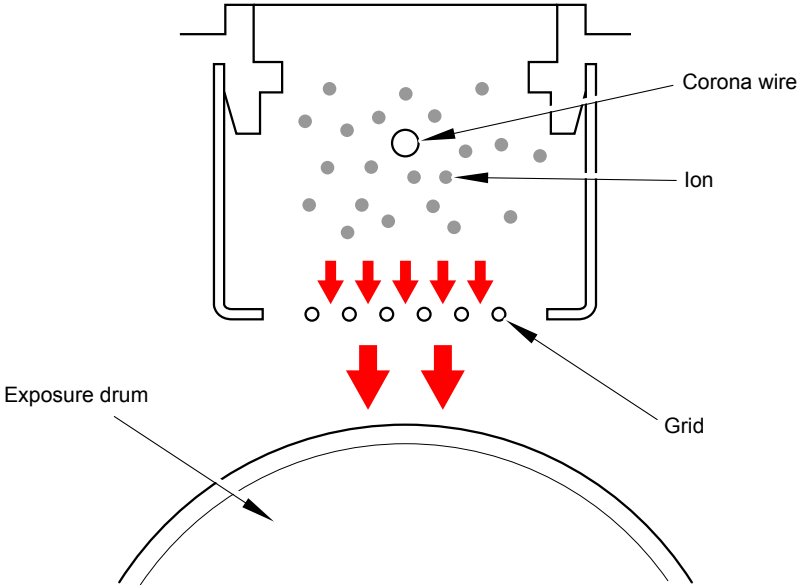

Fig. 2-16



### 3.5.2 Exposure

Exposure is conducted by LED (Light Emitting Diode) arrays. Four LED arrays for K, Y, M and C are mounted as an LED ASSY on the top cover unit of the main unit. These four LED arrays do not emit different colors corresponding to toner colors, and they are the same parts in terms of structure.

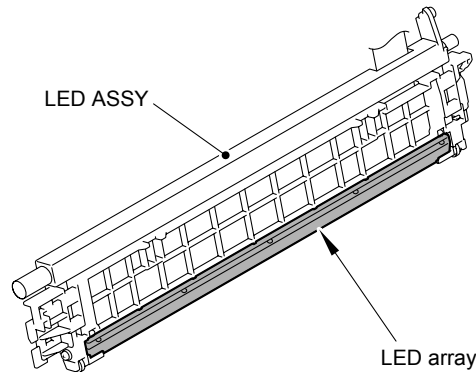

Fig. 2-17

On the PCB in the LED array, 4,992 LEDs, which correspond to the total number of the dots of the 600-dpi print head, are arranged in a staggered pattern. The lens array forms image on the exposure drum using the light emitted from the LEDs. The surface potential on the exposure drum, which is evenly charged, is lowered by exposure, and consequently image is formed.

**Memo:**

- The focus adjustment of the distance between the LED ASSY and exposure drum is made by the lower rollers at the both ends of the LED ASSY, and a fixed distance is maintained.
- Maximum print width is 207.44 mm = 4,900 dots.

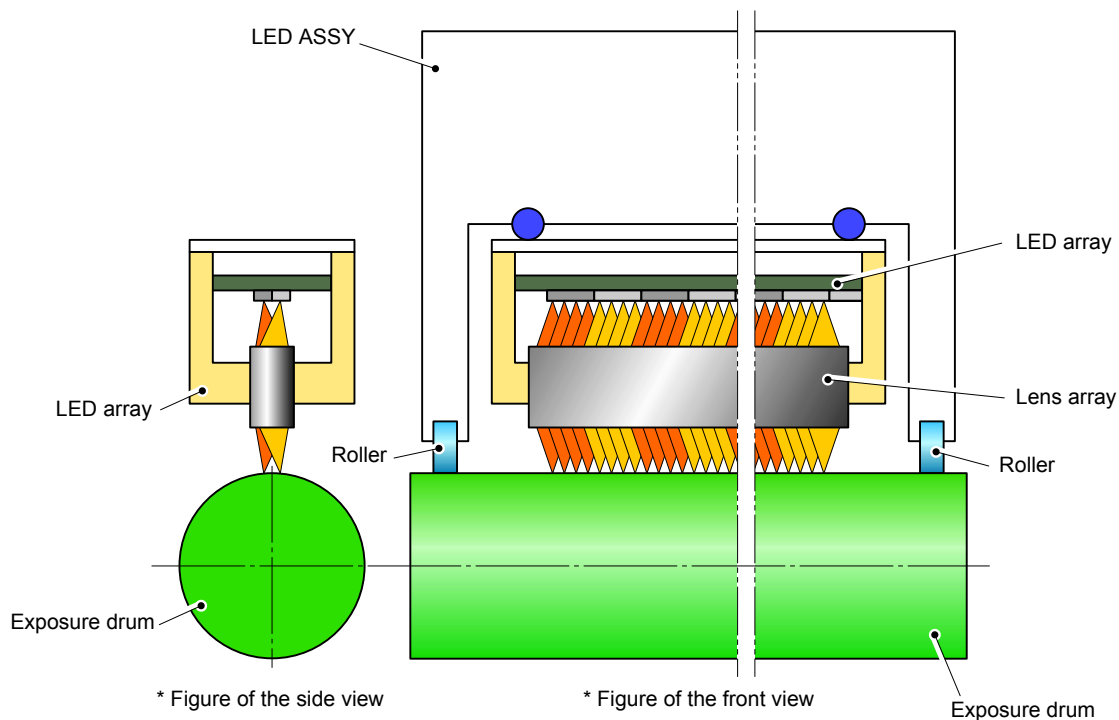

Fig. 2-18

### 3.5.3 Development

Toner is attracted to the latent-image area on the exposure drum where surface potential is lowered due to exposure.

By controlling the developing bias voltage supplied to the develop roller, the amount of toner taken to the exposure drum is adjusted to keep printing density constant.

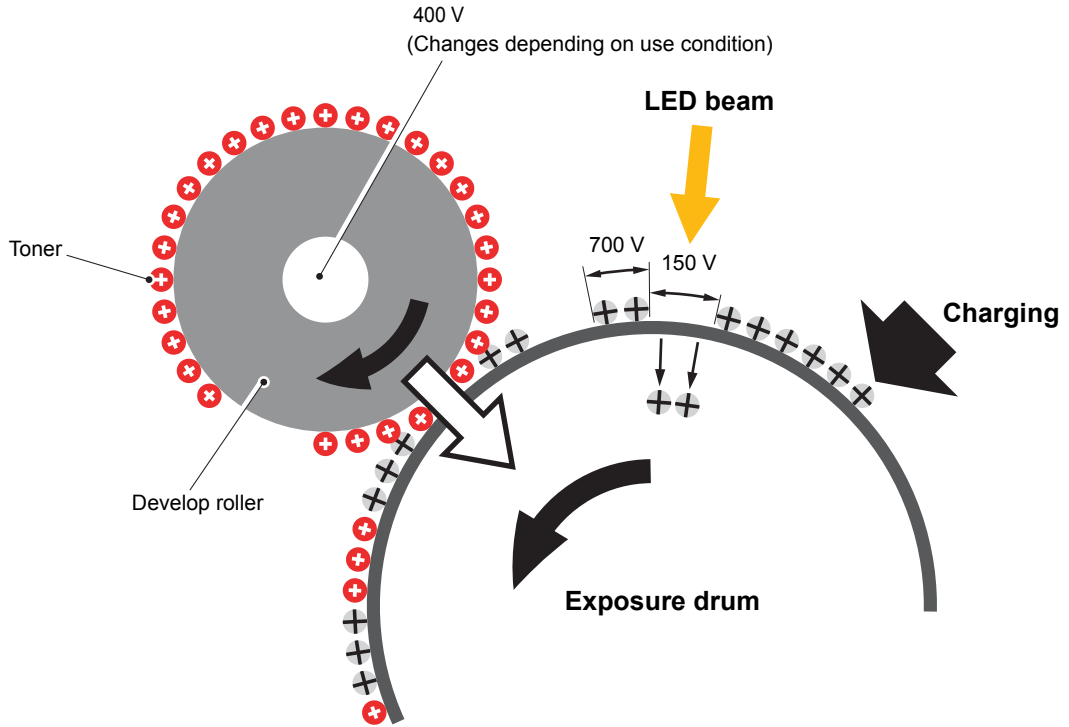

Fig. 2-19

#### <Flow up of toner to the development process>

- (1) Toner adheres to the charged develop roller.
- (2) The thickness of the adhered toner is evened out by the blade.
- (3) The toner adhered to the develop roller is attracted to the exposed areas of the exposure drum.

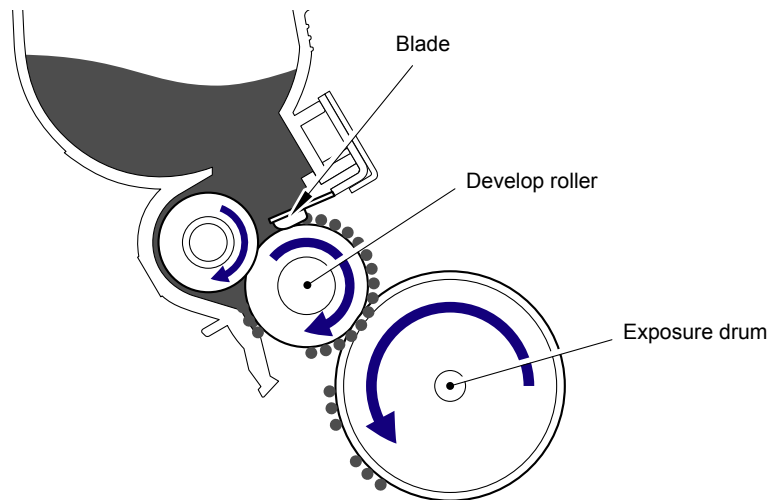

Fig. 2-20

### 3.5.4 Transfer

By applying a minus charge to the transfer roller of the belt unit, the toner adhered to the exposure drum is transferred to paper which is traveling on the feed belt.

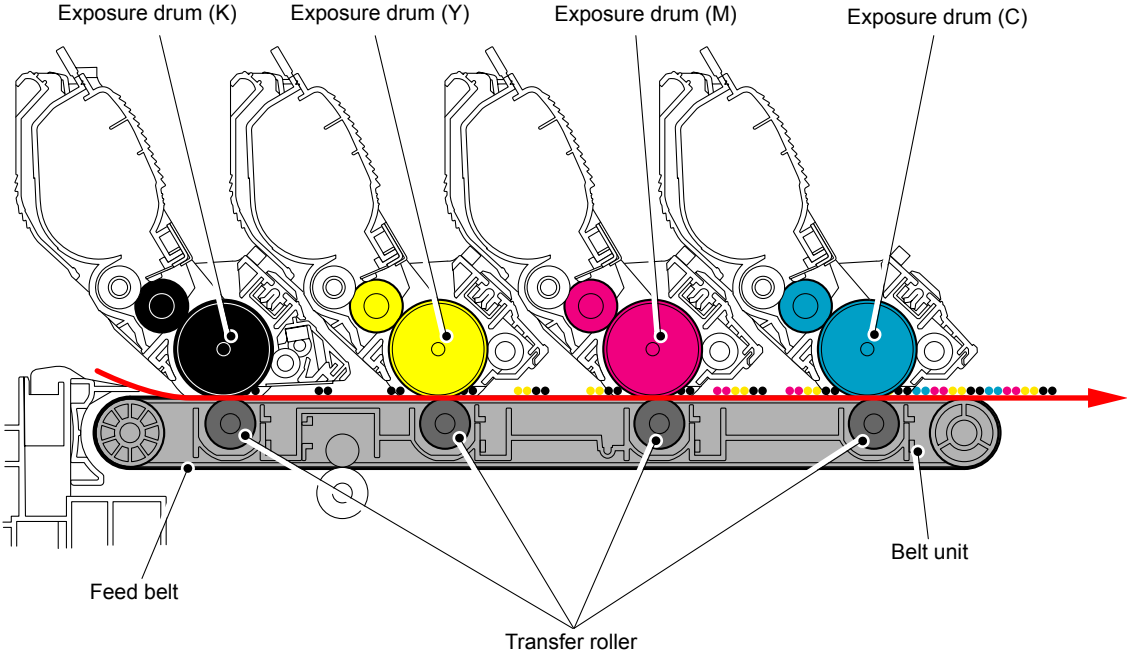

Fig. 2-21

**Memo:**  
 The four colors of toner are coated in turn on the paper to form a color:  
 First comes K, then Y, then M, and then C.

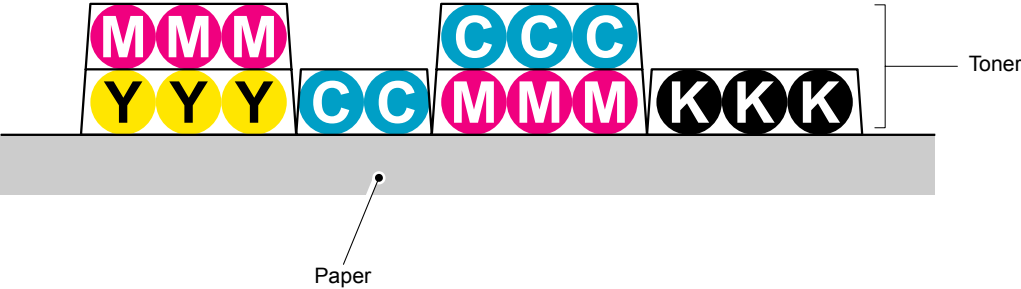

Fig. 2-22

### 3.5.5 Fusing

The toner transferred on to the paper passes between the heat roller and the pressure roller in the fuser unit and are fused by heat and pressure. The main CPU detects surface temperature of the heat roller using the thermistor and turns ON/OFF the halogen heater lamp to keep the temperature constant.

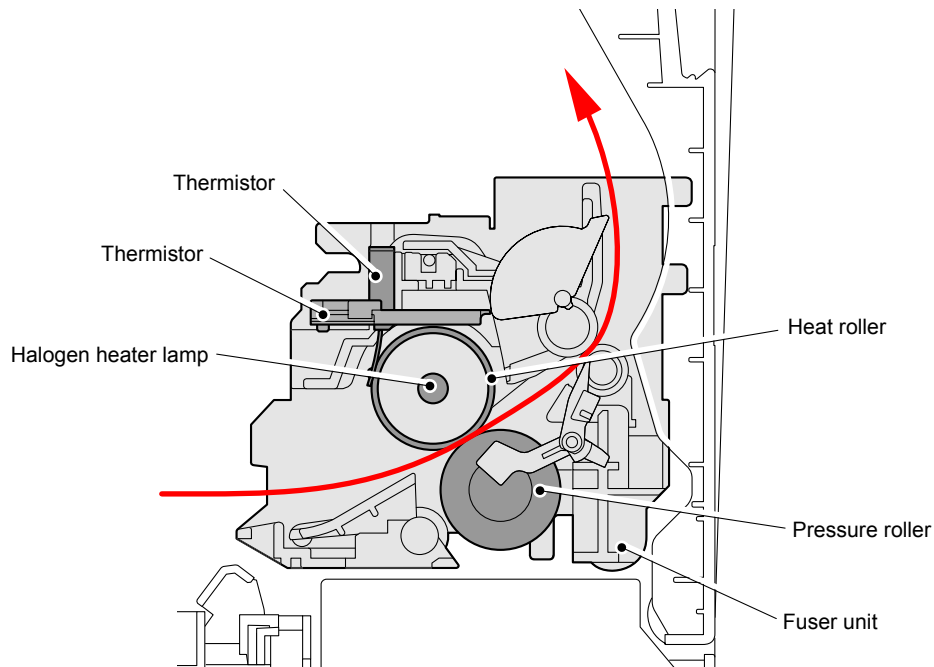

Fig. 2-23

**Memo:**

Control of fusing temperature

The fuser unit adjusts such temperature according to types and sizes of paper so as to keep excellent image quality.

### 3.5.6 Toner cleaning

#### <Flow of toner cleaning>

- (1) Toner remaining on the exposure drum which has not completely been transferred on to the paper is pulled onto the drum cleaner with a lower potential and the drum is cleaned.
- (2) After the above step, the potential of the drum cleaner is raised during printing, and such attracted toner is returned to the exposure drum again. The returned toner is attracted to the belt unit by lowering the potential of the transfer roller.
- (3) The toner attracted to the belt unit is collected by the belt cleaner below the unit, and stored in the waste toner box.

#### Memo:

When the toner returns to the exposure drum from the drum cleaner, the develop roller is separated from the exposure drum to prevent color mixture.

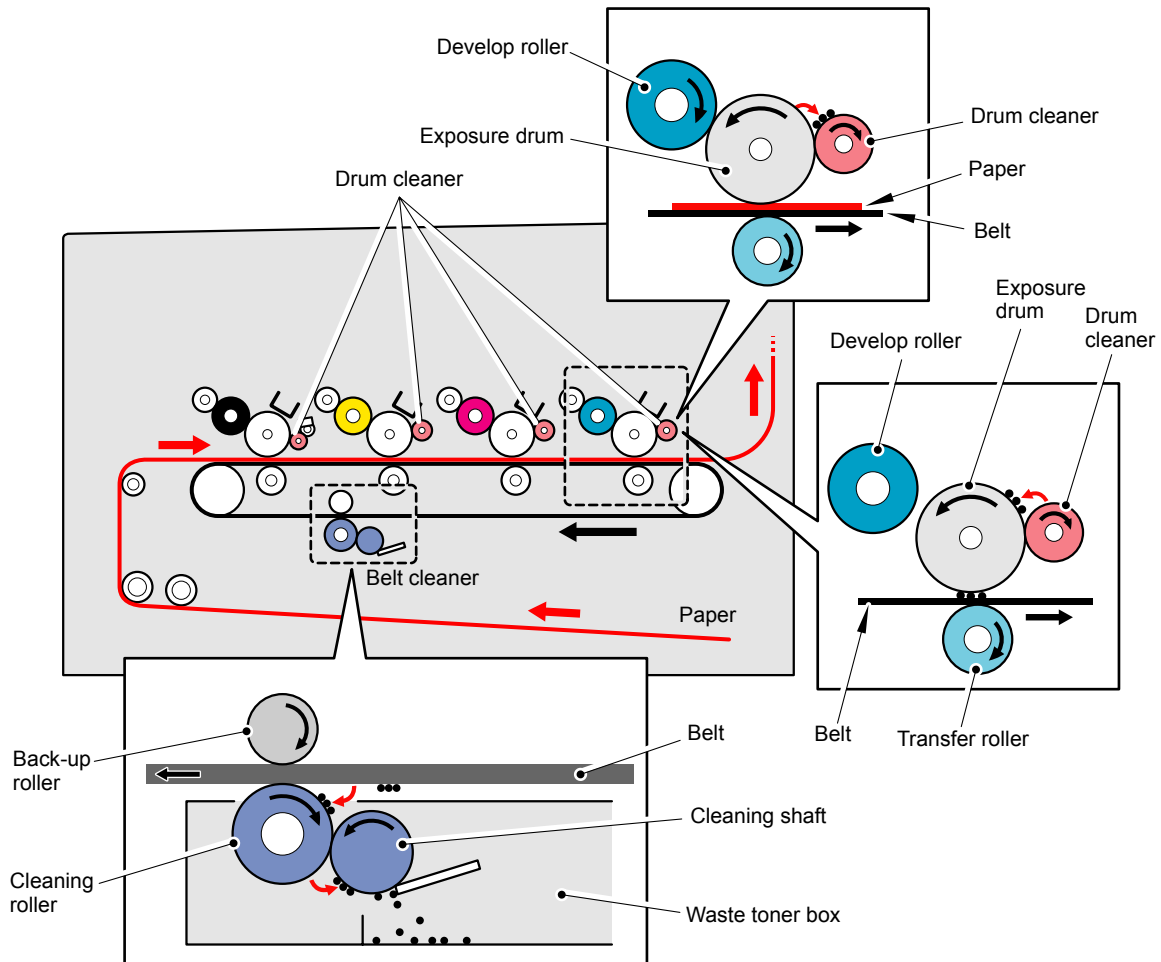

Fig. 2-24

## 3.6 Location of Sensors

Name of sensor	Type	Position	Function
Paper eject rear sensor	Photosensor	On the eject rear sensor PCB ASSY in the paper eject guide ASSY	The paper eject rear actuator detects that the paper passes through the fuser unit to check that no paper jam occurs between the heat roller and exit roller 1.
Manual sensor	Photosensor	On the manual sensor PCB ASSY in the front chute ASSY	Detects if paper is loaded on the manual feed slot.
Top cover open switch	Mechanical switch	On the side frame R	Detects open and close of the top cover.
Back cover sensor	Mechanical switch	On the side frame L	Detects open and close of the Back cover.
Paper eject front sensor (Fuser cover)	Photosensor	On the eject front sensor PCB ASSY in the side frame L	The paper eject front actuator detects that the paper passes through the heat roller to check that no paper winds around the heat roller.
Registration front sensor	Photosensor	On the registration front/rear sensor PCB ASSY in the paper feed unit	Detects if paper from the paper tray is passing through and detects the trailing edge position of paper.
Registration rear sensor	Photosensor	On the registration front/rear sensor PCB ASSY in the paper feed unit	Adjusts the write start position on paper.
New toner sensor	Photosensor	On the toner/new sensor PCB ASSY in the side frame L	Detects if a new toner is mounted.
Toner LED (Light emission)	LED	On the toner LED PCB ASSY in the side frame R	Detects if plenty toner remains.
Toner sensor (Light reception)	Photosensor	On the toner/new sensor PCB ASSY in the side frame L	
Waste toner sensor	Photosensor	On the waste toner sensor holder	Detects if waste toner in the waste toner box is almost full.
External temperature/humidity sensor	Thermistor	On the HVPS control PCB ASSY in the side frame R	Detects ambient temperature and humidity.
Internal temperature sensor	Thermistor	On the drum motor origin sensor PCB ASSY in the side frame L	Detects temperature in the product (L side).

Name of sensor	Type	Position	Function
Belt thermistor	Thermistor	Registration sensor holder ASSY	Detects temperature in the product (at the center).
Drum motor origin sensor	Photosensor	On the drum motor origin sensor PCB ASSY in the side frame L	Detects the phase of the drum motor.
Fuser/eject drive motor sensor	Photosensor	On the fuser/eject drive motor sensor PCB ASSY in the eject gear cover	Detects if the fuser/eject drive motor operates properly.
Registration mark sensor L	Photosensor	On the registration mark L PCB ASSY in the registration sensor holder ASSY	Measures color displacement (L side).
Registration mark sensor R	Photosensor	On the registration mark R PCB ASSY in the registration sensor holder ASSY	Measures color displacement (R side).
Density sensor	Photosensor	On the registration mark L PCB ASSY in the registration sensor holder ASSY	Measures the density of each color.
Develop release sensor	Photosensor	On the develop release sensor PCB ASSY in the side frame R	Detects the distance between the develop roller and exposure drum.
Fuser side thermistor	Thermistor	In the fuser unit	Detects the temperature of the heat roller.
Fuser center thermistor	Thermistor	In the fuser unit	Detects the temperature of the heat roller.

■ Location of sensors

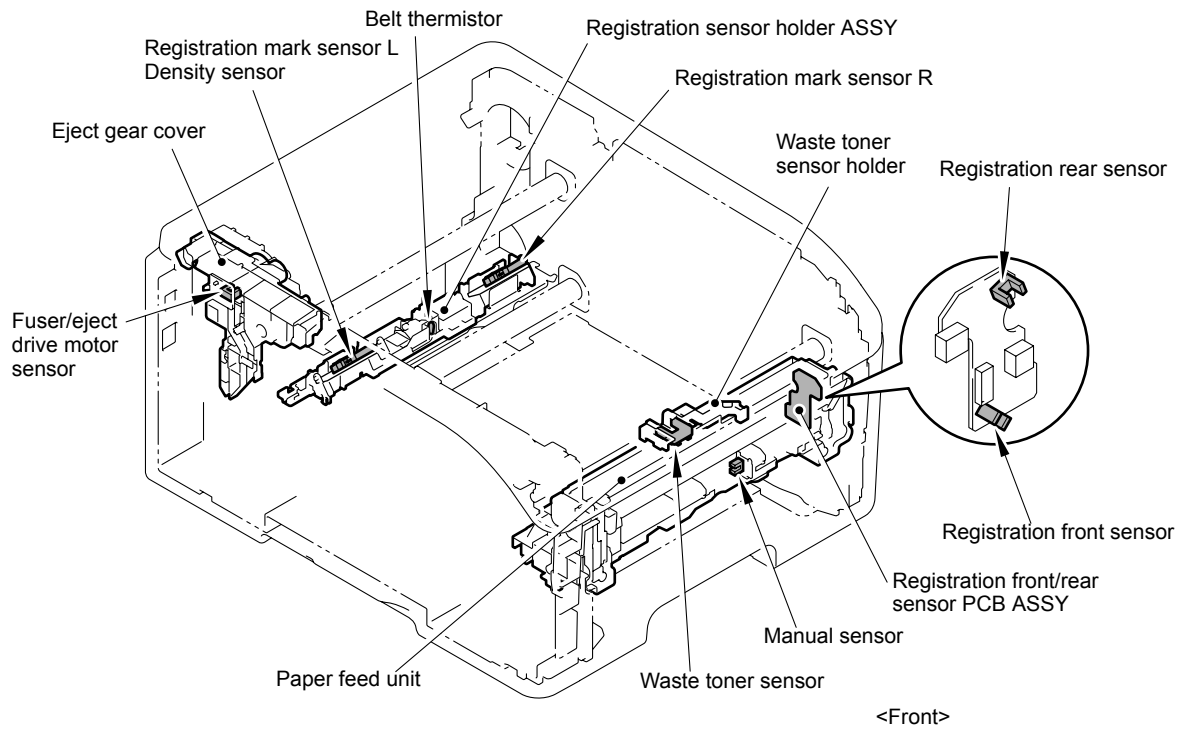

Fig. 2-25

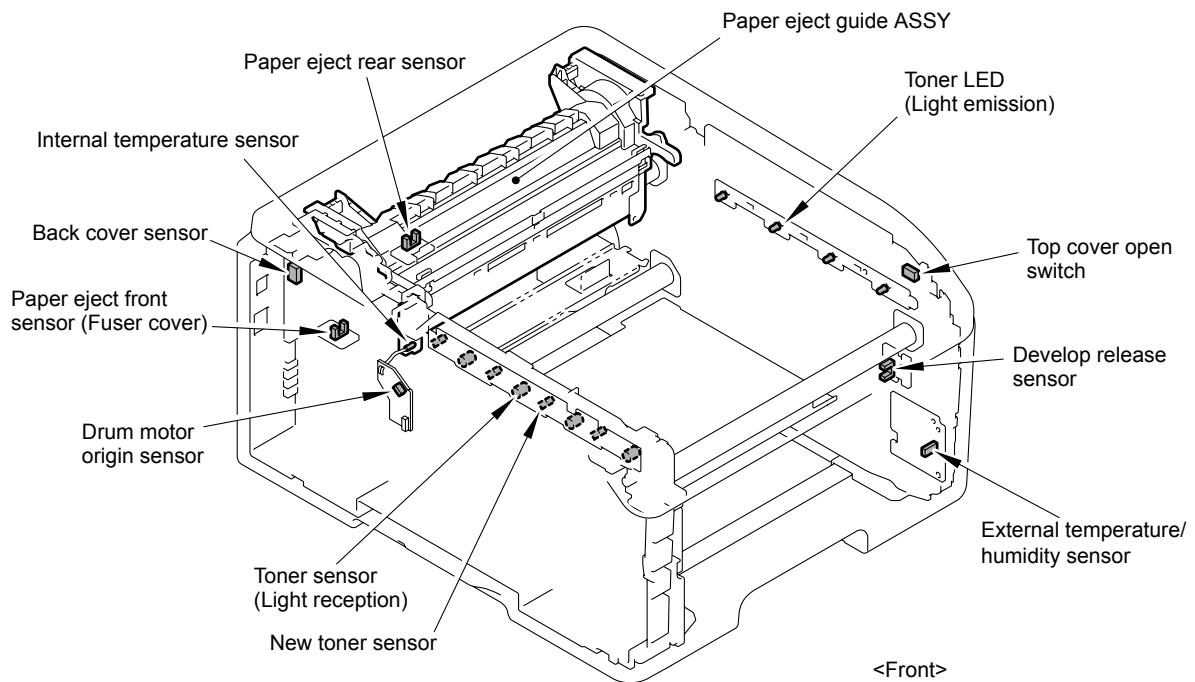
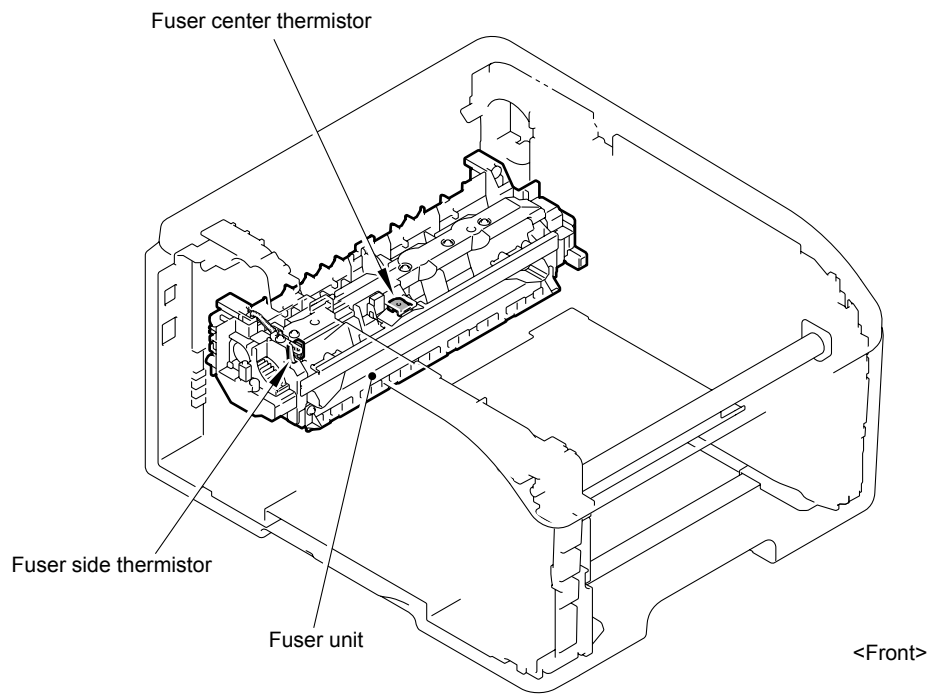

Fig. 2-26





**Fig. 2-27**

## 3.7 Adjustment of Color Registration

In this device, the drum and develop unit are prepared for K, Y, M, and C respectively. Four color images are combined into one image, and therefore color registration error might occur. Auto color registration error correction control is to calculate the color registration error amount and adjust the exposure timing as a means to prevent color registration error.

### ■ Execution timing

- When the continuous print elapsed time reaches a designated time, or when the elapsed time of intermittence print or ready state reaches a designated time.
- Execution from the operation panel (**Function code 66**), etc.
- Immediately after the top cover is opened and closed.
- After the power is turned OFF and ON. (When the specified period of time has passed since the previous execution.)

### 3.7.1 Color registration error in sub/main scanning direction

The color registration test patterns are printed on the belt unit, and the registration mark sensor reads them. The registration mark sensor is a reflective sensor, and the reflection rate is different between the surface of the belt unit and toner. The sensor reads the test patterns using the difference of the reflection rate when the test patterns pass through the sensor. The displacement in the sub/main scanning direction is calculated based on the distance between the patterns read by the registration mark sensor, and it is corrected.

## 3.8 Adjustment of Color Density

To obtain stable print quality, the density of each toner needs to be maintained at a fixed value. If the density balance between the colors cannot be kept, the tint becomes unstable, and accurate color reproduction becomes unavailable. The toner density is changed due to the charged amount of toner, deterioration of the develop unit, and temperature and humidity in the level device. Control to keep the stable print density is made by changing the develop bias voltage.

### ■ Execution timing

- Execution is made at a designated timing (specified in WSW55; the default is 24 hours). (Execution is made when print is started after a specified time has passed.)
- Execution from the operation panel (**Function code 83**), etc.
- Execution is made when toner is replaced with a new one.
- Execution is made when the ambient temperature is changed.

### ■ Operation

The density level adjustment test patterns are printed on the belt unit, and the density sensor reads them. The read density of each color and the density reference value are compared, and if any difference is found, the develop bias voltage is controlled to match the print density to the reference value.

# **CHAPTER 3**

## **ERROR INDICATION AND TROUBLESHOOTING**

# CHAPTER 3

## ERROR INDICATION AND TROUBLESHOOTING

This chapter details error messages and codes which the incorporated self-diagnostic function of the machine will display if any error or malfunction occurs. If any error message appears, refer to this chapter to find which parts should be checked or replaced.

The latter half of this chapter provides sample problems which could occur in the main sections of the machine and related troubleshooting procedures.

### CONTENTS

<b>1. INTRODUCTION .....</b>	<b>3-1</b>
1.1 Precautions.....	3-1
1.2 Components .....	3-2
1.3 Initial Check .....	3-3
<b>2. ERROR INDICATIONS.....</b>	<b>3-5</b>
2.1 Error Codes .....	3-5
2.2 Error Messages .....	3-8
2.3 Error Cause and Remedy.....	3-10
<b>3. PAPER FEEDING PROBLEMS .....</b>	<b>3-51</b>
3.1 No Feeding .....	3-51
3.2 Double Feeding .....	3-52
3.3 Paper Jam .....	3-52
3.4 Dirt on Paper .....	3-54
3.5 Wrinkles on Paper .....	3-54
3.6 Curl of Paper .....	3-55
<b>4. IMAGE DEFECT TROUBLESHOOTING .....</b>	<b>3-56</b>
4.1 Image Defect Examples .....	3-56
4.2 Pitch Indicated in Roller Image.....	3-57
4.3 Troubleshooting Image Defect.....	3-57
<b>5. SOFTWARE SETTING PROBLEMS.....</b>	<b>3-81</b>
5.1 Cannot Print Data .....	3-81
<b>6. NETWORK PROBLEMS .....</b>	<b>3-82</b>
6.1 Cannot Make a Print through Network Connection .....	3-82
<b>7. OTHERS PROBLEMS .....</b>	<b>3-83</b>
7.1 The Machine is Not Turned ON, or The LCD Indication Does Not Appear.....	3-83
7.2 The Fan Does Not Work.....	3-84

# 1. INTRODUCTION

Troubleshooting is the countermeasure procedures that the service personnel should follow if an error or malfunction occurs with the machine. It is impossible to anticipate all of the possible troubles which may occur in future and determine the troubleshooting procedures, so this chapter covers some sample troubles. However, those samples will help the service personnel pinpoint and repair other defective elements.

## 1.1 Precautions

Be sure to observe and follow all the precautions to prevent any secondary problems from happening during troubleshooting.

- (1) Always turn off the power and unplug the power cable before removing any covers or PCBs, adjusting the machine and so on. If you need to take voltage measurements with the power switched on, take the greatest of care not to receive an electric shock.
- (2) When connecting or disconnecting cable connectors, make sure that you hold the connector body and not the cables.
- (3) Static electricity charged in your body may damage electronic parts. Before handling the PCBs, touch a metal portion of the machine to discharge static electricity charged in your body. When transporting PCBs, be sure to wrap them in conductive sheets. When replacing the LED ASSY/PCBs, put on a grounding wrist band and perform the job on a static mat. Also take care not to touch the conductor sections on the flat cables.
- (4) Follow the warning by all means.

 **WARNING**

The fuser unit becomes extremely hot during operation. Wait until it has cooled down sufficiently before replacing consumable items. DO NOT remove or damage the caution label located on or around the fuser.

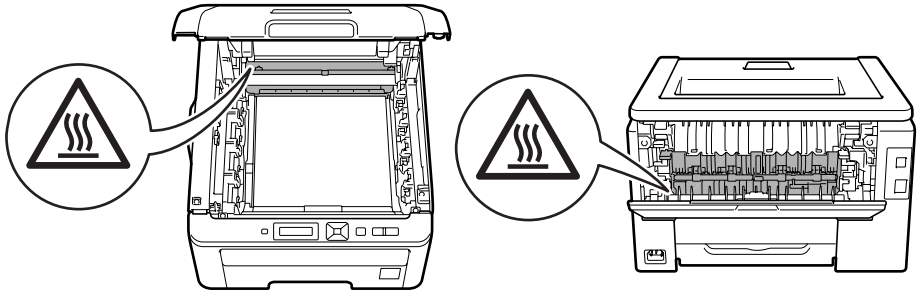

 **WARNING**

**DO NOT** use flammable substances, any type of spray or any organic solvent/liquids contains alcohol or ammonia to clean the inside or outside of the machine. Doing this may cause a fire or electrical shock.



- (5) Verify again that the repaired portion works properly.

## 1.2 Components

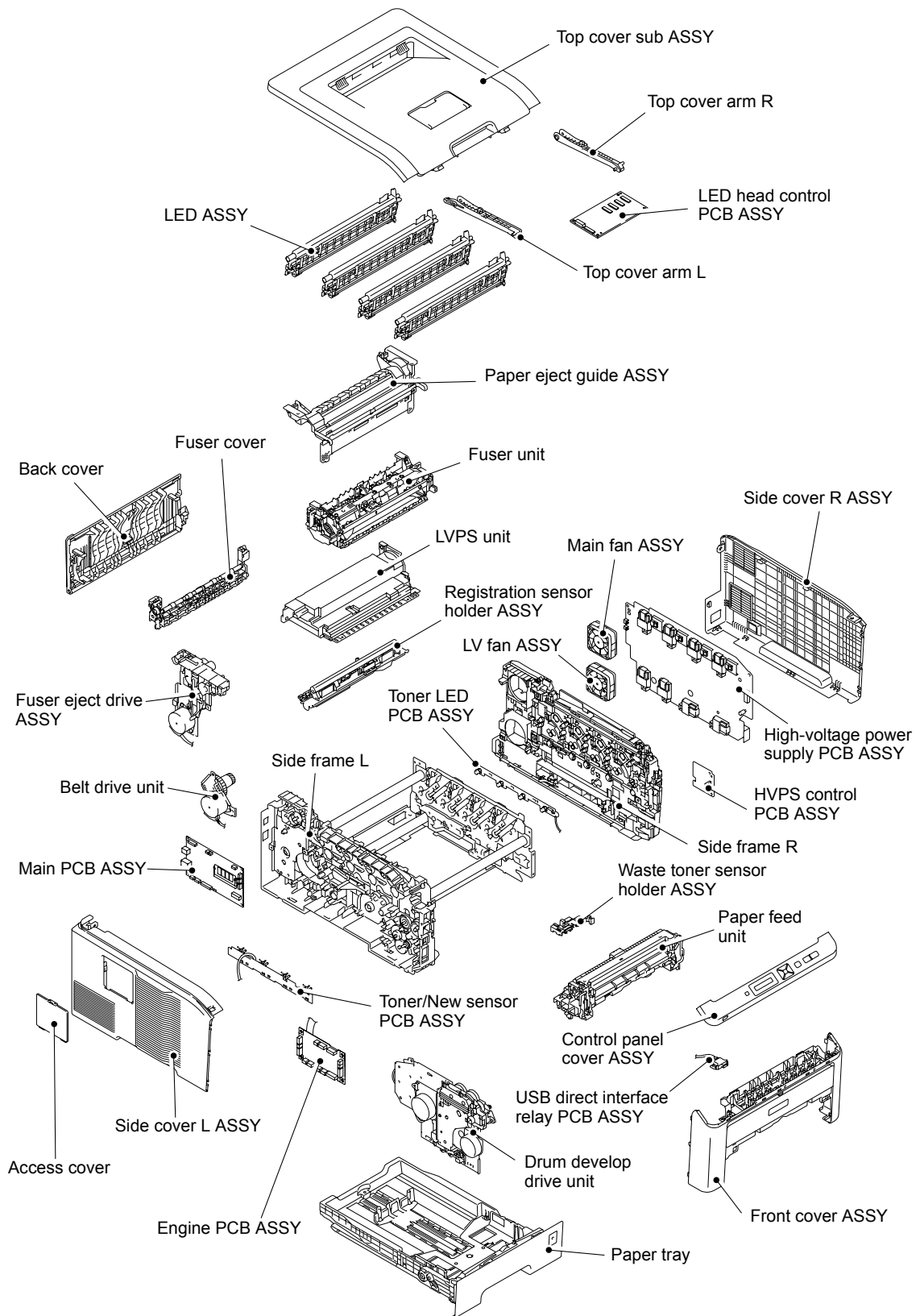

Fig. 3-1

## 1.3 Initial Check

Check the following items before attempting to repair the machine.

### ■ Operating environment

- (1) Put your machine on a flat, stable surface such as a desk that is free of vibration and shocks.
- (2) Use the machine in a well-ventilated room; use the machine within the following ranges of temperature and humidity: temperature between 10 °C and 32.5 °C (50 °F to 90.5 °F), and the relative humidity is maintained between 20 % and 80 %.
- (3) Ensure the machine is not exposed to direct sunlight, excessive heat, moisture, or dust.
- (4) Keep the machine horizontal when you carry it. To prevent injuries when moving or lifting this machine, make sure to use at least two people.

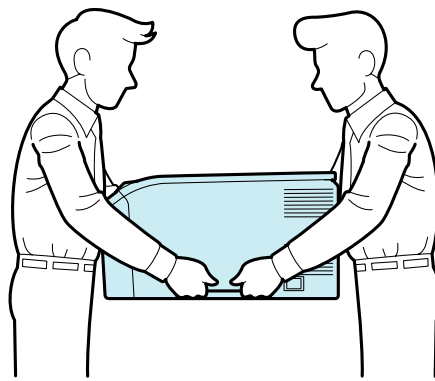

Fig. 3-2

### ■ Power supply

- (1) The AC input power supply described on the rating plate of the machine should be within  $\pm 10\%$  of the rated voltage.
- (2) The AC input power supply is within the regulated value.
- (3) The cables and harnesses are connected correctly.
- (4) The fuses are not blown.

### ■ Paper

- (1) A recommended type of paper is being used. (Refer to “2.5 Paper” in Chapter 1.)
- (2) The paper is not damp.
- (3) The paper is not short-grained paper or acid paper.

### ■ Consumable parts

- (1) The drum unit (including the toner cartridge) is installed correctly.
- (2) The belt unit and waste toner box are installed correctly.

## ■ Others

### (1) Condensation

When the machine is moved from a cold place into a warm room, condensation may occur inside the machine, causing various problems as listed below.

- Condensation on the optical surfaces such as the LED array may cause the print image to be light.
- If the exposure drum is cold, the electrical resistance of the photosensitive layer is increased, making it impossible to obtain the correct contrast when printing.
- Condensation on the charge unit may cause corona charge leakage.
- Condensation on the plate and separation pad may cause paper feed problems.

If condensation has occurred, leave the machine for at least two hours to allow it to reach room temperature.

If the drum unit is unpacked soon after it is moved from a cold place to a warm room, condensation may occur inside the unit which may cause incorrect images. Instruct the user to allow the unit to come to room temperature before unpacking it. This will take one or two hours.

### (2) Low temperature



The motor may not drive normally under the low temperature environment. This is due to there being too much load to drive each unit. In this case, the “**Low Temperature/Increase room temperature to allow the machine to operate**” message will appear on the LCD. Increase the room temperature when the above message is indicated.

## ■ Cleaning

Use a soft dry lint-free cloth.

 **WARNING**

**DO NOT** use flammable substances, any type of spray or any organic solvent/liquids contains alcohol or ammonia to clean the inside or outside of the machine. Doing this may cause a fire or electrical shock.





## 2. ERROR INDICATIONS

This machine includes a self-diagnosis function. If the machine does not work normally it judges that an error has occurred, and indicates the corresponding error message on the LCD, which in turn helps the service men to quickly find out the problem.

### 2.1 Error Codes

Error codes	Problem	Refer to:	Error codes	Problem	Refer to:
13	Developing bias correction failure (Error, which cannot be recorded, occurs.)	3-10	33	Right color registration sensor error	3-18
			34	Left color registration sensor error	3-18
14	Developing bias correction failure (Toner life end)	3-10	36	HVPS PCB error in ready state	3-19
			37	Belt thermistor error	3-19
15	Developing bias correction failure (Incorrect measurement value of developing bias correction)	3-11	38	External temperature sensor error	3-20
			39	External humidity sensor error	3-20
			3A	Engine PCB transfer error	3-20
16	Color registration adjustment failure (Error, which cannot be recorded, occurs.)	3-11	3B	Main PCB RAM error	3-21
			3E	NVRAM transfer error	3-21
17	Color registration adjustment failure (Toner life end)	3-11	40	HVPS PCB error in operating	3-19
			42	HVPS control PCB transfer error	3-21
18	Color registration adjustment failure (Incorrect measurement value of color registration adjustment)	3-12	43	Main/Engine ASIC transfer error	3-22
			44	No toner cartridge (K)	3-22
			45	No toner cartridge (Y)	3-22
1A	Dew condensation on high-voltage power supply PCB	3-12	46	No toner cartridge (M)	3-22
			47	No toner cartridge (C)	3-22
1B	Drum error (C)	3-13	48	Drum life end (K)	3-23
1C	Drum error (M)	3-13	49	Drum life end (Y)	3-23
1D	Drum error (Y)	3-13	4A	Drum life end (M)	3-23
20	LED ASSY error (K)	3-14	4B	Drum life end (C)	3-23
21	LED ASSY error (Y)	3-14	4C	Drum life end soon (K)	3-23
22	LED ASSY error (M)	3-14	4D	Drum life end soon (Y)	3-23
23	LED ASSY error (C)	3-14	4E	Drum life end soon (M)	3-23
24	Internal temperature sensor error	3-14	4F	Drum life end soon (C)	3-23
25	Develop drive motor error	3-15	52	Paper feeding kit life end	3-23
26	Belt drive motor error	3-15	54	Fuser unit life end	3-24
28	Drum drive motor error	3-15	56	Fuser cover opened	3-24
29	Belt cleaner drive motor error	3-15	58	Fuser unit error (Some kind of temperature error of the fuser unit occurs.)	3-25
2A	Develop release motor error	3-15			
2C	Toner/New sensor PCB error (K)	3-16	59	Fuser unit error (Re-detection of fuser unit failure upon startup after the error code 58 occurs.)	3-25
2D	Toner/New sensor PCB error (Y)	3-16			
2E	Toner/New sensor PCB error (M)	3-16			
2F	Toner/New sensor PCB error (C)	3-16	5B	Short paper	3-26
31	Density sensor error	3-17	5C	Small paper	3-26
32	Density sensor shutter performance malfunction	3-17	5D	Belt unit life end soon	3-26
			5E	Belt unit life end	3-27

Error codes	Problem	Refer to:	Error codes	Problem	Refer to:
5F	Waste toner box near full	3-27	84	Paper jam at the back of the machine inside	3-35
60	Toner life end (C)	3-28			
61	Toner life end (M)	3-28			
62	Toner life end (Y)	3-28			
63	Toner life end (K)	3-28			
64	Toner life end soon (C)	3-29			
65	Toner life end soon (M)	3-29	87	Toner of the color which is being used reaches the end of life when implementing adjustment of color density from the control panel cover ASSY.	3-30
66	Toner life end soon (Y)	3-29	88	Paper jam inside the machine	3-35
67	Toner life end soon (K)	3-29	8A	Paper jam in paper tray	3-36
6A	Fuser unit error (The center thermistor does not detect 60 °C within the specified time.)	3-25	8D	Eject front sensor sticking at ON upon startup	3-36
6B	Fuser unit error (The center thermistor does not detect 100 °C within the specified time.)	3-25	8E	Error in the adjustment of color registration result when implementing it from the control panel cover ASSY.	3-37
6C	Fuser unit error (The center thermistor detects higher temperature than the specified value.)	3-25	8F	Detection of abnormal value of registration sensor sensitivity when implementing adjustment of color registration from the control panel cover ASSY	3-37
6D	Fuser unit error (The center thermistor detects lower temperature than the specified value.)	3-25	91	Size mismatch	3-37
6F	Fuser unit error (The center or side thermistors detect extremely high temperature.)	3-25	94	No paper in paper tray	3-38
70	Fuser/Eject drive motor error	3-29	96	No paper in all trays	3-39
73	Recording ASIC read/write error	3-30	97	Not supported paper	3-39
74	Toner of the color which is being used reaches the end of life while printing.	3-30	9A	No paper in manual feed slot	3-39
75	Machine cooling down inside	3-31	9D	Detection of incorrect registration sensor measurement value when implementing adjustment of color registration from the control panel cover ASSY	3-37
76	Fuser unit error (The center thermistor detects rapid temperature rising.)	3-25	9E	Toner of the color which is being used reaches the end of life when implementing adjustment of color registration from the control panel cover ASSY.	3-30
78	Fuser unit error (The center thermistor detects rapid temperature falling.)	3-26	9F	No paper while printing	3-40
7D	Dirt on drum unit	3-31	A1	Top cover opened	3-40
81	Incorrect density sensor measurement value when implementing adjustment of color density from the control panel cover ASSY.	3-34	C0	Identification failure for a new toner cartridge (K)	3-41
82	Density patch measurement is not completed normally when implementing adjustment of color density from the control panel cover ASSY.	3-34	C1	Identification failure for a new toner cartridge (Y)	3-41
			C2	Identification failure for a new toner cartridge (M)	3-41
			C3	Identification failure for a new toner cartridge (C)	3-41
			C6	Pressure engagement/disengagement failure of toner cartridge	3-42
83	Drum error (K)	3-13	C7	Insufficient memory	3-42

Error codes	Problem	Refer to:	Error codes	Problem	Refer to:
C8	RAM area for secure data full	3-42	EF	Low-voltage power supply PCB failure	3-47
C9	DIMM error	3-43	F2	Waste toner box near full	3-48
CA	Excess current to USB device	3-43	F4	Waste toner box life end	3-48
CB	No belt unit	3-44	F9	Power turned OFF while the function code 74 is being executed and "PARAMETER INT" is being displayed	3-48
CE	No waste toner box	3-44			
CF	Waste toner box full	3-45			
DE	Thermistor of fuser unit misconnected	3-45	FA	No drum unit (K)	3-49
E0	Program error	3-45	FB	No drum unit (C)	3-49
E1	Program error	3-46	FC	No drum unit (M)	3-49
E2	Temperature error of heat roller	3-46	FD	No drum unit (Y)	3-49
E3	Drum motor origin sensor failure	3-46	FE	Detection of incorrect measurement value of density sensor sensitivity calibration	3-50
E6	Write error in EEPROM	3-21			
E9	Maintenance monitor error	3-47			
EC	Main fan error	3-47	FF	Overcurrent error of wireless LAN PCB	3-50

## 2.2 Error Messages

The error messages displayed on the LCD of the product and their description and measure are shown in the table below.

Error message	Description/ Measure	Refer to:
<b>Access Error</b> (HL-3070CW only)	The USB device was removed while data was processing. Press <b>Cancel</b> button. Reinsert the USB device and try to print with Direct Print or PictBridge.	3-43
<b>Belt End Soon</b>	The belt unit is near the end of its life. Buy a new belt unit before you get a "Replace Belt" message.	3-26
<b>Calibrate</b> Scroll message: <b>Calibration failed.</b> <b>See</b> <b>Troubleshooting</b> <b>chapter in User's</b> <b>guide.</b>	<ul style="list-style-type: none"> <li>- Turn off the printer. Wait a few seconds and turn it on again.</li> <li>- Put in a new drum unit.</li> <li>- Put in a new belt unit.</li> <li>- Put in a new waste toner box.</li> </ul>	3-30 3-34 3-50
<b>Cartridge Error</b>	Take out the drum unit and toner cartridge assembly for the toner color that is indicated on the LCD. Remove the toner cartridge and then re-install it in the drum. Put the drum unit and toner cartridge assembly back into the printer again.	3-41
<b>Cover is Open</b>	Close the cover that is indicated on the LCD.	3-24 3-36 3-40
<b>DIMM Error</b>	Turn off the printer. Re-install the DIMM correctly. Wait a few seconds and turn it on again. If this error message appears again, replace the DIMM with a new one.	3-43
<b>Drum End Soon (X) * or Drums End Soon</b>	The drum unit is near the end of its life. Buy a new drum unit that is indicated on the LCD before you get a "Replace Drum" message.	3-23
<b>Drum Error</b>	Clean the corona wires. If the LCD still shows the same error message after you have cleaned the corona wire, replace the drum unit with a new one that is indicated on the LCD.	3-13 3-31
<b>Fuser Error</b>	Turn off the power switch, wait a few seconds and then turn it on again. Leave the printer for 15 minutes with the power on.	3-25 3-45
<b>Jam XXX</b>	Carefully pull out the jammed paper from the area shown in the message.	3-35 3-36 3-52
<b>Low Temperature</b>	Increase room temperature to allow the printer to operate.	---
<b>Manual Feed</b>	Put the same size of paper in the manual feed slot as is shown on the LCD. If the printer is "paused", press <b>Go</b> button.	3-39
<b>No Belt Unit</b>	Install the belt unit.	3-44
<b>No Paper</b>	Put paper in the indicated empty tray. If the problem is not solved, the paper pick-up roller may be stained. Clean the paper pick-up roller.	3-39 3-40
<b>No Toner</b>	Install the toner cartridge that is indicated on the LCD. Install the drum unit that is indicated on the LCD.	3-49

\* (X) at the end of the message shows the color of the toner cartridge or drum unit. (X) must be either K (Black), Y (Yellow), M (Magenta) or C (Cyan).

Error message	Type of error	Refer to:
<b>No Waste Toner</b>	Install the waste toner box.	3-44
<b>Out of Memory</b>	If the LCD shows this error message when you print the secure data, press <b>Cancel</b> button and delete the previously stored data. Except in the case of printing secure data and add more memory.	3-42
<b>Print Unable ##</b>	Turn off the printer. Wait a few seconds and turn it on again.	3-12 1 3-47
<b>Registration</b> Scroll message: <b>Registration failed.</b> <b>See</b> <b>Troubleshooting</b> <b>chapter in User's</b> <b>guide.</b>	- Turn off the printer. Wait a few seconds and turn it on again. - Put in a new belt unit.	3-30 3-37
<b>Replace Belt</b>	It is time to replace the belt unit. Replace the belt unit.	3-27
<b>Replace Drum (X) *</b> or <b>Replace Drums</b>	It is time to replace the drum unit. Replace the drum unit that is indicated on the LCD.	3-23
<b>Replace Toner</b>	It is time to replace the toner cartridge. Replace the toner cartridge that is indicated on the LCD.	3-28
<b>Replace WT Box</b>	It is time to replace the waste toner box. Replace the waste toner box.	3-45 3-48
<b>Replace Fuser</b>	It is time to replace the fuser unit. Replace the fuser unit.	3-24
<b>Replace PF Kit1</b>	It is time to replace the paper feeding kit. Replace the paper feeding kit.	3-23
<b>Short paper</b>	Open the back cover (back-output tray) to let the printed paper out on the back-output tray and then press <b>Go</b> button.	3-26
<b>Size Mismatch</b>	Put the same size paper in the paper tray or manual feed slot that is selected in the printer driver, and then press <b>Go</b> button or select the size of paper which you set in the paper tray size setting from the control panel cover ASSY.	3-37
<b>Small paper</b>	Open the back cover (back-output tray) to let the printed paper out on the back-output tray and then press <b>Go</b> button.	3-26
<b>Toner Error</b>	Dismount the drum unit of the color displayed on the LCD or all the drum units, and then take out the toner cartridge from the drum unit(s). Put the toner cartridge back to the drum unit(s), and remount the drum unit(s) to the printer.	3-42
<b>Toner Low (X) *</b>	The toner cartridge is nearly empty. Buy a new toner cartridge that is indicated on the LCD before you get a "Replace Toner" message.	3-29
<b>Unusable Device</b> (HL-3070CW only)	Remove the USB flash memory drive from the USB Direct Interface.	3-43 3-50
<b>WT Box End Soon</b>	The waste toner box will need replacement soon. Buy a new waste toner box before you get a "Replace WT Box" message.	3-27

\* (X) at the end of the message shows the color of the toner cartridge or drum unit.  
(X) must be either K (Black), Y (Yellow), M (Magenta) or C (Cyan).

## 2.3 Error Cause and Remedy

Check the **User Check** items first. If an error cannot be resolved, follow the procedures in numerical order in the Step field.

### ■ Error code 13

-
---

An error, which cannot be recorded, occurs while correction of developing bias is performed.

#### <User Check>

- Replace the belt unit with a new one.
- Replace the waste toner box with a new one.

Step	Cause	Remedy
1	Registration mark L PCB ASSY failure	Replace the registration sensor holder ASSY.
2	HVPS control PCB failure	Replace the HVPS control PCB ASSY.
3	High-voltage power supply PCB failure	Replace the high-voltage power supply PCB ASSY.
4	Main PCB failure	Replace the main PCB ASSY.

### ■ Error code 14

-
---

Toner reaches its life end while correction of developing bias is performed.  
This error is not recorded in the error log.

#### <User Check>

- Replace the cartridge of toner which reaches its life end with a new one.

Step	Cause	Remedy
1	Main PCB failure	Replace the main PCB ASSY.

■ **Error code 15**

-

Correction of developing bias fails.

**<User Check>**

- Replace the belt unit with a new one.

Step	Cause	Remedy
1	Registration mark L PCB ASSY failure	Replace the registration sensor holder ASSY.
2	HVPS control PCB failure	Replace the HVPS control PCB ASSY.
3	High-voltage power supply PCB failure	Replace the high-voltage power supply PCB ASSY.
4	Main PCB failure	Replace the main PCB ASSY.

■ **Error code 16**

-

An error, which cannot be recorded, occurs while auto color registration is performed.

**<User Check>**

- Replace the belt unit with a new one.

Step	Cause	Remedy
1	Registration mark L PCB ASSY failure	Replace the registration sensor holder ASSY.
2	Main PCB failure	Replace the main PCB ASSY.

■ **Error code 17**

-

Toner reaches its life end while auto color registration is performed.

This error is not recorded in the error log.

**<User Check>**

- Replace the cartridge of toner which reaches its life end with a new one.

Step	Cause	Remedy
1	Main PCB failure	Replace the main PCB ASSY.

■ **Error code 18**

-

Auto color registration fails.

**<User Check>**

- Replace the belt unit with a new one.
- Replace the waste toner box with a new one.

Step	Cause	Remedy
1	Registration mark L PCB ASSY failure	Replace the registration sensor holder ASSY.
2	HVPS control PCB failure	Replace the HVPS control PCB ASSY.
3	High-voltage power supply PCB failure	Replace the high-voltage power supply PCB ASSY.
4	Main PCB failure	Replace the main PCB ASSY.

■ **Error code 1A**

**Print Unable 1A**  
**Turn the power switch off and open the Top Cover. Wait 30 minutes, and then turn it on again.**

Dew condensation might have occurred in the machine. (The temperature/humidity sensor on the high voltage control PCB detects sudden environmental change.) / High-voltage power supply PCB error/ Drum unit error

**<User Check>**

- Power off and open the top cover. Wait 30 minutes, and then turn it ON again after closing the top cover.
- Clean the corona wire in the drum unit.
- Replace the drum unit with a new one.

Step	Cause	Remedy
1	Dirt on drum unit electrodes	Clean the electrodes of the drum unit and main body. (Refer to Fig. 3-3 (P3-32) and Fig. 3-6 (P3-33))
2	HVPS control PCB failure	Replace the HVPS control PCB ASSY.
3	High-voltage power supply PCB failure	Replace the high-voltage power supply PCB ASSY.



## ■ Error code 1B

**Drum Error**  
**Replace the Drum Unit. Cyan (C). Refer to the User's Guide.**

## Error code 1C

**Drum Error**  
**Replace the Drum Unit. Magenta (M). Refer to the User's Guide.**

## Error code 1D

**Drum Error**  
**Replace the Drum Unit. Yellow (Y). Refer to the User's Guide.**

## Error code 83

**Drum Error**  
**Replace the Drum Unit. Black (K). Refer to the User's Guide.**

Drum error

\* After the error code 48, 49, 4A, or 4B (the drum unit is at the end of life) occurs, and when the counter value exceeds twice the life expectancy and electric discharge occurs due to smear on the corona wire, and disturbance is detected in the charge current of the high-voltage power supply PCB, the error code 83, 1B, 1C, or 1D appears. When the error code 83, 1B, 1C, or 1D appears, the performance of the drum unit cannot be maintained, and the print quality is deteriorated, and therefore the use of the drum is stopped.

### <User Check>

- Replace the drum unit of the appropriate color with a new one.
- After replacing the drum unit with a new one, reset the counter using the control panel cover ASSY on the machine. (Refer to “2.3 Parts Life Reset Function” in Chapter 7.)

■ **Error code 20 (K), 21 (Y), 22 (M), 23 (C)**

<p><b>Print Unable 20</b> Turn the power off and then back on again.</p>
<p><b>Print Unable 21</b> Turn the power off and then back on again.</p>
<p><b>Print Unable 22</b> Turn the power off and then back on again.</p>
<p><b>Print Unable 23</b> Turn the power off and then back on again.</p>

LED ASSY error (EEPROM access error of the LED head)

Step	Cause	Remedy
1	FFC connection failure of each LED ASSY	Check the FFC connection of the appropriate color and reconnect it.
2	LED head control PCB failure	Replace the LED head control PCB ASSY.
3	Failure of each LED ASSY	Replace the LED ASSY of the appropriate color.
4	Main PCB failure	Replace the main PCB ASSY.
5	Low-voltage power supply PCB failure	Replace the low-voltage power supply PCB ASSY.

■ **Error code 24**

<p><b>Print Unable 24</b> Turn the power off and then back on again.</p>
--

Internal temperature sensor error

Step	Cause	Remedy
1	Internal temperature sensor failure	Replace the drum motor origin sensor PCB ASSY.
2	Engine PCB failure	Replace the engine PCB ASSY.
3	Main PCB failure	Replace the main PCB ASSY.

■ **Error code 25**

**Print Unable 25**  
**Turn the power off and then back on again.**

Develop drive motor error (Incorrect synchronized signal of the develop drive motor)

**Error code 26**

**Print Unable 26**  
**Turn the power off and then back on again.**

Belt drive motor error

**Error code 28**

**Print Unable 28**  
**Turn the power off and then back on again.**

Drum drive motor error (Incorrect synchronized signal of the drum drive motor)

**Error code 29**

**Print Unable 29**  
**Turn the power off and then back on again.**

Belt cleaner drive motor error (Incorrect synchronized signal of the belt cleaner drive motor)

Step	Cause	Remedy
1	Harness connection failure of motor	Check the harness connection of the appropriate motor and reconnect it.
2	Motor failure	Replace the appropriate motor.
3	Engine PCB failure	Replace the engine PCB ASSY.
4	Main PCB failure	Replace the main PCB ASSY.
5	Low-voltage power supply PCB failure	Replace the low-voltage power supply PCB ASSY.

■ **Error code 2A**

**Print Unable 2A**  
**Turn the power off and then back on again.**

Develop release motor error

Step	Cause	Remedy
1	Harness connection failure of develop release motor	Check the harness connection of the develop release motor and reconnect it.
2	Develop release motor failure	Replace the develop release motor ASSY.
3	Engine PCB failure	Replace the engine PCB ASSY.
4	HVPS control PCB failure	Replace the HVPS control PCB ASSY.
5	Main PCB failure	Replace the main PCB ASSY.

■ Error code 2C (K), 2D (Y), 2E (M), 2F (C)

**Print Unable 2C**  
Turn the power off and then back on again.

**Print Unable 2D**  
Turn the power off and then back on again.

**Print Unable 2E**  
Turn the power off and then back on again.

**Print Unable 2F**  
Turn the power off and then back on again.

Toner/New sensor PCB error (The toner sensor is ON while the toner LED sensor is not ON.)

Step	Cause	Remedy
1	Toner/new sensor PCB failure	Check the sensor performance following the procedure described in "Function code 32". If any problem occurs, replace the toner/new sensor PCB ASSY.
2	Engine PCB failure	Replace the engine PCB ASSY.
3	Main PCB failure	Replace the main PCB ASSY.

■ **Error code 31**

**Print Unable 31**  
**Turn the power off and then back on again.**

Density sensor error (Incorrect measurement value of the density sensor)

**Error code 32**

**Print Unable 32**  
**Turn the power off and then back on again.**

Density sensor shutter performance malfunction

**<User Check>**

- Check if there is a scratch, dirt or the like on the belt unit. If there is, replace the belt unit with a new one.

Step	Cause	Remedy
1	Harness connection failure of registration mark L PCB ASSY	Check the harness connection between the registration mark L PCB ASSY and registration mark relay PCB ASSY, and the one between the registration mark relay PCB ASSY and engine PCB ASSY. Then, reconnect them.
2	Harness connection failure of density sensor shutter solenoid	Check the harness connection of the density sensor shutter solenoid and reconnect it.
3	Registration mark L PCB failure	Replace the registration sensor holder ASSY.
4	Engine PCB failure	Replace the engine PCB ASSY.
5	Main PCB failure	Replace the main PCB ASSY.

■ **Error code 33**

**Print Unable 33**  
**Turn the power off and then back on again.**

Right color registration sensor error  
(Incorrect reading value of the color registration sensor (Right))

**Error code 34**

**Print Unable 34**  
**Turn the power off and then back on again.**

Left color registration sensor error  
(Incorrect reading value of the color registration sensor (Left))

**<User Check>**

- Check if there is a scratch, dirt or the like on the belt unit. If there is, replace the belt unit with a new one.

Step	Cause	Remedy
1	Harness connection failure of registration mark PCB ASSY	Check the harness connection of the registration mark PCB ASSY and reconnect it.
2	Registration mark PCB failure	Check the performance of the registration mark sensor following the procedure described in "Function code 75". If any problem occurs, replace the registration sensor holder ASSY.
3	Engine PCB failure	Replace the engine PCB ASSY.
4	Main PCB failure	Replace the main PCB ASSY.

■ **Error code 36**

**Print Unable 36**  
**Turn the power off and then back on again.**

Error occurs while the high-voltage power supply PCB is in ready state.

**Error code 40**

**Print Unable 40**  
**Turn the power off and then back on again.**

Error occurs while the high-voltage power supply PCB is in operation

\* After the error code 36 is displayed for 5 seconds, the power of the main unit is forcibly turned off, and it takes 10 minutes to recover.

**<User Check>**

- Clean the corona wire in the drum unit.
- Replace the drum unit with a new one.

Step	Cause	Remedy
1	Dirt on drum unit electrodes	Clean the electrodes of the drum unit and main body. (Refer to Fig. 3-3 (P3-32) and Fig. 3-6 (P3-33))
2	Harness connection failure of high-voltage power supply PCB ASSY	Check the harness connection between the high-voltage power supply PCB ASSY and engine PCB ASSY, and the one between the high-voltage power supply PCB ASSY and main PCB ASSY. Then, reconnect them.
3	HVPS control PCB failure	Replace the HVPS control PCB ASSY.
4	High-voltage power supply PCB failure	Replace the high-voltage power supply PCB ASSY.
5	Engine PCB failure	Replace the engine PCB ASSY.
6	Main PCB failure	Replace the main PCB ASSY.

■ **Error code 37**

**Print Unable 37**  
**Turn the power off and then back on again.**

Belt thermistor error

Step	Cause	Remedy
1	Harness connection failure of belt thermistor ASSY	Check the harness connection of the belt thermistor ASSY.
2	Main PCB failure	Replace the main PCB ASSY.

■ **Error code 38**

**Print Unable 38**  
**Turn the power off and then back on again.**

External temperature sensor error

■ **Error code 39**

**Print Unable 39**  
**Turn the power off and then back on again.**

External humidity sensor error

Step	Cause	Remedy
1	HVPS control PCB failure	Replace the HVPS control PCB ASSY.
2	Main PCB failure	Replace the main PCB ASSY.

■ **Error code 3A**

**Print Unable 3A**  
**Turn the power off and then back on again.**

Engine PCB transfer error (disconnection)

Step	Cause	Remedy
1	Harness connection failure of engine PCB ASSY	Check the harness connection between the main PCB ASSY and engine PCB ASSY, and reconnect it.
2	Engine PCB failure	Replace the engine PCB ASSY.
3	Main PCB failure	Replace the main PCB ASSY.



■ **Error code 3B**

**Print Unable 3B**  
**Turn the power off and then back on again.**

Main PCB RAM error (DIMM access error)

**Error code 3E**

**Print Unable 3E**  
**Turn the power off and then back on again.**

NVRAM transfer error

**Error code E6**

**Print Unable E6**  
**Turn the power off and then back on again.**

Write error in EEPROM

Step	Cause	Remedy
1	Main PCB failure	Replace the main PCB ASSY.

■ **Error code 42**

**Print Unable 42**  
**Turn the power off and then back on again.**

HVPS control PCB transfer error

Step	Cause	Remedy
1	Harness connection failure of high-voltage power supply PCB ASSY	Check the harness connection between the high-voltage power supply PCB ASSY and HVPS control PCB ASSY, and reconnect it.
2	Harness connection failure of HVPS control PCB ASSY	Check the harness connection between the HVPS control PCB ASSY and main PCB ASSY, and reconnect it.
3	HVPS control PCB failure	Replace the HVPS control PCB ASSY.
4	High-voltage power supply PCB failure	Replace the high-voltage power supply PCB ASSY.
5	Main PCB failure	Replace the main PCB ASSY.

■ **Error code 43**

**Print Unable 43**  
**Turn the power off and then back on again.**

Main/Engine ASIC transfer error

Step	Cause	Remedy
1	Harness connection failure between the main PCB ASSY and engine PCB ASSY	Check the harness connection between the main PCB ASSY and engine PCB ASSY, and reconnect it.
2	Engine PCB failure	Replace the engine PCB ASSY.
3	Main PCB failure	Replace the main PCB ASSY.

■ **Error code 44 (K), 45 (Y), 46 (M), 47 (C)**

**No Toner**  
**Open the Top Cover, then install Toner Cartridge. Black (K)**

**No Toner**  
**Open the Top Cover, then install Toner Cartridge. Yellow (Y)**

**No Toner**  
**Open the Top Cover, then install Toner Cartridge. Magenta (M)**

**No Toner**  
**Open the Top Cover, then install Toner Cartridge. Cyan (C)**

Toner cartridge is not installed into the machine.  
 (Non-installation is detected by the toner sensor.)

**<User Check>**

- Install the toner cartridge of the appropriate color.

Step	Cause	Remedy
1	Harness connection failure of toner/new sensor PCB ASSY	Check the harness connection of the toner/new sensor PCB ASSY and reconnect it.
2	Engine PCB failure	Replace the engine PCB ASSY.
3	Main PCB failure	Replace the main PCB ASSY.
4	Toner/new sensor PCB failure	Replace the toner/new sensor PCB ASSY.

■ **Error code 48 (K), 49 (Y), 4A (M), 4B (C)**

- Replace Drum (K)**
- Replace Drum (Y)**
- Replace Drum (M)**
- Replace Drum (C)**

Drum unit is at the end of life. (The drum counter value reaches the end of life.)

\* When all four colors reach the end of life at the same time.

**Replace Drums**

**<User Check>**

- Replace the drum unit of the appropriate color with a new one.
- After replacing the drum unit, reset the counter using the control panel cover ASSY on the machine. (Refer to ["2.3 Parts Life Reset Function" in Chapter 7.](#))

■ **Error code 4C (K), 4D (Y), 4E (M), 4F (C)**

- Drum End Soon (K)**
- Drum End Soon (Y)**
- Drum End Soon (M)**
- Drum End Soon (C)**

The drum unit will reach the end of life soon. (The drum counter value reaches 90 % of life.)

\* When all four colors reach 90 % of the life at the same time.

**Drums End Soon**

**<User Check>**

- Prepare a new drum unit of the appropriate color.

■ **Error code 52**

**Replace PF Kit1**

Paper feeding kit is at the end of life.

(The counter value of the paper feeding kit reaches the end of life.)

Step	Cause	Remedy
1	Paper feeding kit worn out	Replace the paper feeding kit.

■ **Error code 54**

**Replace Fuser**

Fuse unit is at the end of life. (The counter value of the fuser unit reaches the end of life.)

Step	Cause	Remedy
1	Fuser unit is at the end of life.	Replace the fuser unit.

■ **Error code 56**

**Cover is Open**  
**Close the Fuser Cover which can be found behind the Back Cover of the machine.**

Fuser cover opened (Eject front sensor sticking at ON)

**<User Check>**

- Check if the fuser cover is closed correctly.

Step	Cause	Remedy
1	Paper eject front actuator catching on some position	Correct catching of the paper eject front actuator.
2	Eject front sensor PCB failure	Replace the eject front sensor PCB ASSY.
3	Main PCB failure	Replace the main PCB ASSY.

## ■ Error code 58

**Fuser Error**  
**Turn the power off, then on again. Leave the machine for 15 min.**

Fuser unit error (Some kind of temperature error of the fuser unit occurs.)

## Error code 59

**Self-Diagnostic**  
**Will Automatically Restart within 15 minutes.**

Fuser unit error (Re-detection of fuser unit failure upon startup after the error code 58 occurs.)

\* If the same error is detected again 15 minutes later, the message below is indicated.

## Error code 6A

**Print Unable 6A**  
**Turn the power off and then back on again.**

Fuser unit error (The center thermistor does not detect 60 °C within the specified time.)

## Error code 6B

**Print Unable 6B**  
**Turn the power off and then back on again.**

Fuser unit error (The center thermistor does not detect 100 °C within the specified time.)

## Error code 6C

**Print Unable 6C**  
**Turn the power off and then back on again.**

Fuser unit error (The center thermistor detects higher temperature than the specified value.)

## Error code 6D

**Print Unable 6D**  
**Turn the power off and then back on again.**

Fuser unit error (The center thermistor detects lower temperature than the specified value.)

## Error code 6F

**Print Unable 6F**  
**Turn the power off and then back on again.**

Fuser unit error (The center or side thermistors detect extremely high temperature.)

## Error code 76

**Print Unable 76**  
**Turn the power off and then back on again.**

Fuser unit error (The center thermistor detects rapid temperature rising.)

Refer to the [next page](#) for remedy.

## Error code 78

**Print Unable 78**  
**Turn the power off and then back on again.**

Fuser unit error (The center thermistor detects rapid temperature falling.)

Step	Cause	Remedy
1	Harness connection failure between fuser unit connector and eject front sensor PCB ASSY	Check the harness connection between the fuser unit connector and eject front sensor PCB ASSY, and reconnect it.
2	Harness connection failure between eject front sensor PCB ASSY and main PCB ASSY	Check the harness connection between the eject front sensor PCB ASSY and main PCB ASSY, and reconnect it.
3	Fuser unit failure	Replace the fuser unit.
4	Low-voltage power supply PCB failure	Replace the low-voltage power supply PCB ASSY.
5	Eject front sensor PCB failure	Replace the eject front sensor PCB ASSY.
6	Main PCB failure	Replace the main PCB ASSY.

## ■ Error code 5B

**Short paper**  
**Open the Back Cover and then press Go.**

Paper of which size is not supported is used. (Paper of less than 148 mm length is fed.)

### <User Check>

- Open the back cover and remove the paper.

## ■ Error code 5C

**Small paper**  
**Open the Back Cover and then press Go.**

Paper of which size is not supported is used.  
(Paper of less than 148 mm length is specified from a computer.)

### <User Check>

- Open the back cover and make print, or change the paper specified from a computer to larger-size paper.

## ■ Error code 5D

**Belt End Soon**

The belt unit will reach the end of life soon. (The belt unit counter value reaches 90 % of life.)

### <User Check>

- Prepare a new belt unit.

## ■ Error code 5E

### Replace Belt

The belt unit is at the end of life. (The belt unit counter value reaches the end of life.)

#### <User Check>

- Replace the belt unit with a new one.
- After replacing the belt unit, reset the counter using the control panel cover ASSY on the machine. (Refer to “2.3 Parts Life Reset Function” in Chapter 7.)

## ■ Error code 5F

### WT Box End Soon

The waste toner box near full. (The waste toner sensor detects the always ON state.)

#### Note:

The same message appears in the case of the error code F2.

#### <User Check>

- Prepare a new waste toner box.

Step	Cause	Remedy
1	Harness connection failure of waste toner sensor	Check the harness connection of the waste toner sensor and reconnect it.
2	Waste toner sensor failure	Check the sensor performance following the procedure described in “Function code 32”. If any problem occurs, replace the waste toner sensor.
3	HVPS control PCB failure	Replace the HVPS control PCB ASSY.
4	Main PCB failure	Replace the main PCB ASSY.

■ **Error code 60 (C), 61 (M), 62 (Y), 63 (K)**

<p><b>Replace Toner</b>  <b>Open the Top Cover, replace Toner Cartridge. Cyan (C).</b></p>
<p><b>Replace Toner</b>  <b>Open the Top Cover, replace Toner Cartridge. Magenta (M).</b></p>
<p><b>Replace Toner</b>  <b>Open the Top Cover, replace Toner Cartridge. Yellow (Y).</b></p>
<p><b>Replace Toner</b>  <b>Open the Top Cover, replace Toner Cartridge. Black (K).</b></p>

Toner cartridge is at the end of life. (The counter value of the develop roller reaches the end of life, or the toner sensor detects toner empty.)

**<User Check>**

- Gently shake the toner cartridge of the appropriate color from side to side and install it again.
- Replace the toner cartridge of the appropriate color.

Step	Cause	Remedy
1	HVPS control PCB failure	Replace the HVPS control PCB ASSY.
2	Engine PCB failure	Replace the engine PCB ASSY.
3	Main PCB failure	Replace the main PCB ASSY.
4	Harness connection failure of toner/new sensor PCB ASSY	Check the sensor performance following the procedure described in "Function code 32". If any problem occurs, check the harness connection of the toner/new sensor PCB ASSY of the appropriate color, then reconnect it.
5	Toner/new sensor PCB failure	Replace the toner/new sensor PCB ASSY.



■ **Error code 64 (C), 65 (M), 66 (Y), 67 (K)**

**Toner Low (#)**

\* Any of K, Y, M, or C, which refer to colors, is indicated in #.

Toner cartridge will reach the end of life soon. (The counter value of the develop roller reaches 90 % of life, or the toner sensor detects toner near empty.)

**<User Check>**

- Gently shake the toner cartridge of the appropriate color from side to side and install it again.
- Replace the toner cartridge of the appropriate color.

Step	Cause	Remedy
1	HVPS control PCB failure	Replace the HVPS control PCB ASSY.
2	Engine PCB failure	Replace the engine PCB ASSY.
3	Main PCB failure	Replace the main PCB ASSY.
4	Harness connection failure of toner/new sensor PCB ASSY	Check the sensor performance following the procedure described in "Function code 32". If any problem occurs, check the harness connection of the toner/new sensor PCB ASSY, then reconnect it.
5	Toner/new sensor PCB failure	Replace the toner/new sensor PCB ASSY.

■ **Error code 70**

**Print Unable 70**  
**Turn the power off and then back on again.**

Fuser/Eject drive motor error

Step	Cause	Remedy
1	Harness connection failure of fuser/eject drive motor	Check the harness connection of the fuser/eject drive motor and reconnect it.
2	Harness connection failure of fuser/eject drive motor sensor PCB ASSY	Check the harness connection of the fuser/eject drive motor sensor PCB ASSY and reconnect it.
3	Fuser/eject drive motor failure	Replace the fuser/eject drive motor.
4	Fuser/eject drive motor sensor PCB ASSY failure	Replace the fuser/eject drive motor sensor PCB ASSY.
5	Engine PCB failure	Replace the engine PCB ASSY.
6	Main PCB failure	Replace the main PCB ASSY.

■ **Error code 73**

**Print Unable 73**  
**Turn the power off and then back on again.**

Recording ASIC read/write error

Step	Cause	Remedy
1	Harness connection failure of LED head control PCB ASSY	Check the harness connection between the main PCB ASSY and LED head control PCB ASSY, and reconnect them.
2	LED head control PCB failure	Replace the LED head control PCB ASSY.
3	Main PCB failure	Replace the main PCB ASSY.

■ **Error code 74** (This error can be found out only in “**Function code 82**”.)

**Replace Toner**

Toner of the color which is being used reaches the end of life while printing.  
 (The counter value of the develop roller reaches the end of life, or the toner sensor detects toner empty.) This error is not recorded in the error log.

**Error code 87**

**Calibrate**  
**Calibration failed. Insufficient Toner for Calibration.**

Toner of the color which is being used reaches the end of life when implementing adjustment of color density from the control panel cover ASSY. (The counter value of the develop roller reaches the end of life, or the toner sensor detects toner empty.)

**Error code 9E**

**Registration**  
**Registration failed. Insufficient Toner for Registration.**

Toner of the color which is being used reaches the end of life when implementing adjustment of color registration from the control panel cover ASSY. (The counter value of the develop roller reaches the end of life, or the toner sensor detects toner empty.)

**<User Check>**

- If any of the toner cartridges reaches the end of life, replace it with a new one.

Step	Cause	Remedy
1	Toner/new sensor PCB failure	Check the sensor performance following the procedure described in “ <b>Function code 32</b> ”. If any problem occurs, replace the toner/new sensor PCB ASSY.
2	Engine PCB failure	Replace the engine PCB ASSY.

## ■ Error code 75

### **Cooling Down Wait for a while**

Cooling down the inside of the machine to protect it.

The machine indicates “Cooling Down” in one of the conditions below.

- The temperature inside the machine is high.
- Both ends of the heat roller are heated extraordinarily.
- The paper media is replaced.

## ■ Error code 7D

### **Drum Error Slide the Green tab on Drum Unit. Black (K)/ Yellow (Y)/ Magenta (M)/ Cyan (C). Refer to the User's Guide.**

Dirt on drum unit (Detection of discharge of the corona wire)

#### <User Check>

- Clean the corona wire in the drum unit.
- Replace the drum unit of the appropriate color with a new one.

Step	Cause	Remedy
1	Dirt or dust on drum unit electrodes	Clean the electrodes of the drum unit, belt unit and main body. (Refer to Fig. 3-3, Fig-3-4 (next page) and Fig. 3-6 (P3-33))
2	HVPS control PCB failure	Replace the HVPS control PCB ASSY.
3	High-voltage power supply PCB failure	Replace the high-voltage power supply PCB ASSY.
4	Main PCB failure	Replace the main PCB ASSY.

■ Electrodes location of the drum unit and toner cartridge

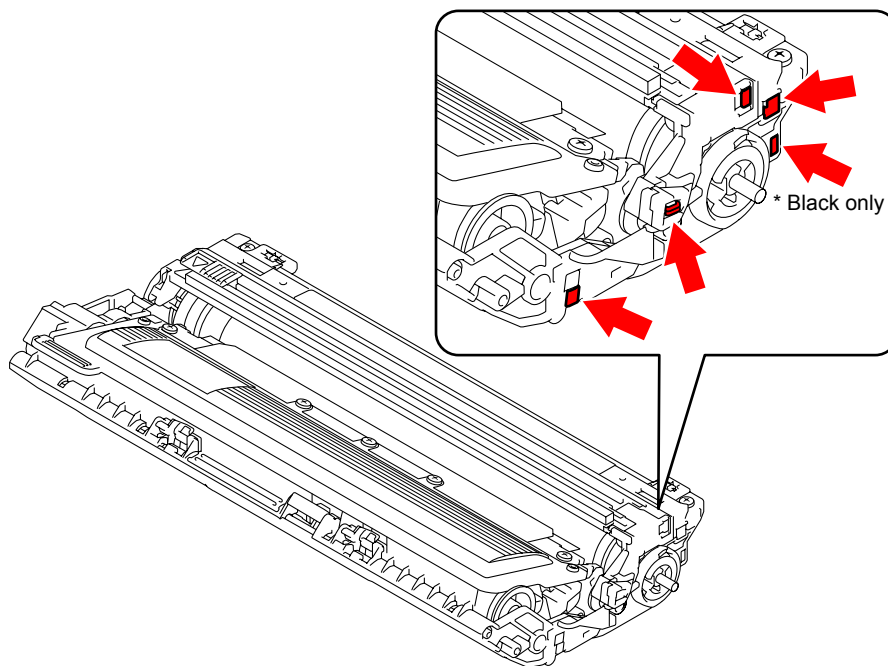

Fig. 3-3

■ Electrodes location of the belt unit

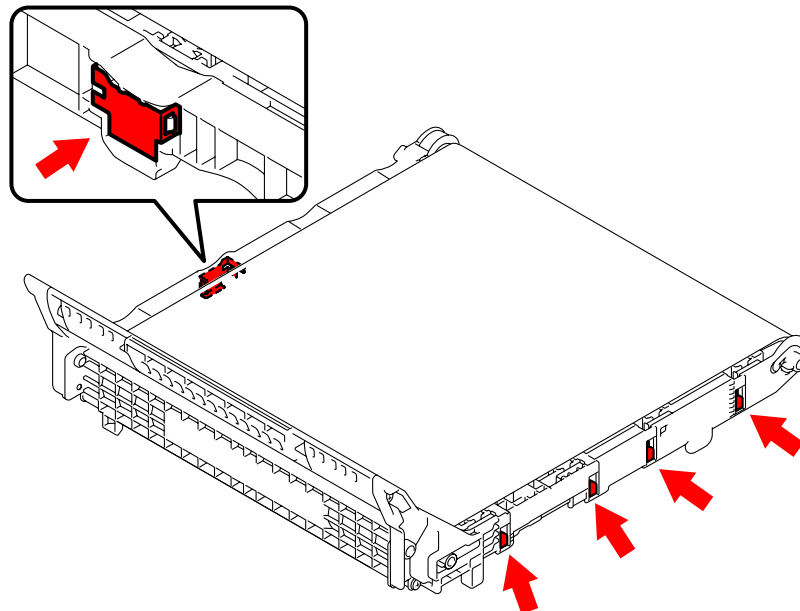

Fig. 3-4

### ■ Electrodes location of waste toner box

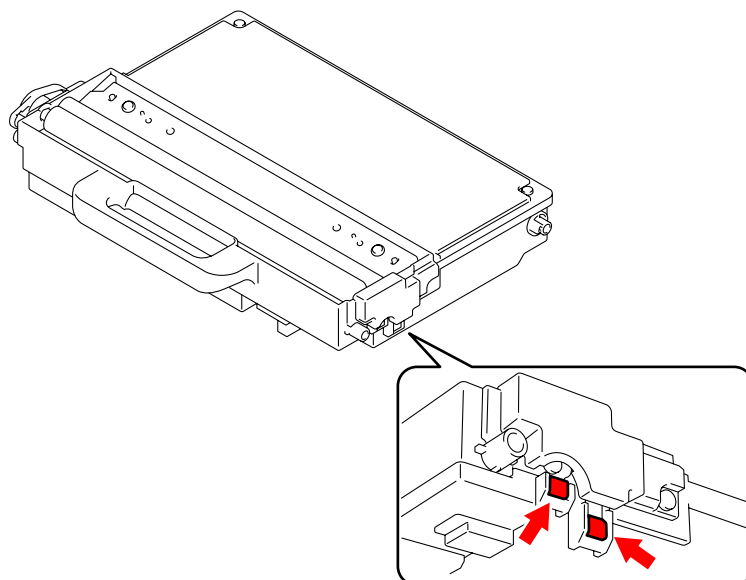

Fig. 3-5

### ■ Electrodes location of main body

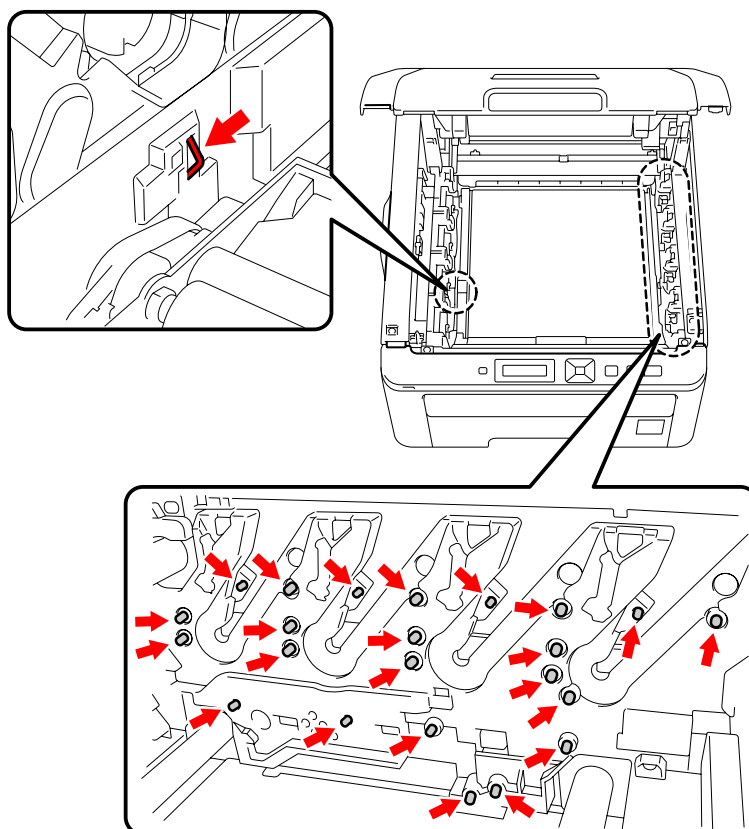

Fig. 3-6

#### <How to clean the electrodes>

Turn off the power switch. Unplug the machine from the AC power outlet, and leave the machine for a few minutes. Then, wipe the electrodes above carefully with a dry lint-free cloth. Be careful not to change the shapes of the electrodes.

## ■ Error code 81

**Calibrate**  
**Calibration failed. See Troubleshooting chapter in User's Guide.**

Incorrect density sensor measurement value when implementing adjustment of color density from the control panel cover ASSY.

## Error code 82

**Calibrate**  
**Calibration failed. Press Go, and try again.**

Density patch measurement is not completed normally when implementing adjustment of color density from the control panel cover ASSY.

### <User Check>

- Check if there is a scratch, dirt or the like on the belt unit. If there is, replace the belt unit with a new one.
- Check if the genuine toner cartridges are installed in the correct order of colors.

Step	Cause	Remedy
1	Density sensor shutter catching on some position	Correct catching of the density sensor shutter.
2	Harness connection failure of registration mark L PCB ASSY	Check the harness connection of the registration mark L PCB ASSY and reconnect it.
3	HVPS control PCB failure	Replace the HVPS control PCB ASSY.
4	Engine PCB failure	Replace the engine PCB ASSY.
5	Main PCB failure	Replace the main PCB ASSY.
6	Registration mark L PCB failure	Replace the registration sensor holder ASSY.

■ **Error code 84**

**Jam Rear**  
**Open the Back Cover and remove the jammed paper, then press Go.**

Paper jam at the back of the machine inside  
 (The eject front sensor sticks at ON after the registration rear actuator is turned OFF.)

**Error code 88**

**Jam Inside**  
**Open the Top Cover, pull out all 4 Drum Units completely and remove the jammed paper.**

Paper jam inside the machine  
 (The registration rear actuator sticks at ON, or the eject front sensor fails to be turned ON.)

**<User Check>**

- Check if the paper is jammed. If jammed, remove it.

Step	Cause	Remedy
1	Harness connection failure of registration front/rear sensor PCB ASSY and eject front sensor PCB ASSY	Check the harness connections of the registration front/rear sensor PCB ASSY and eject front sensor PCB ASSY, and reconnect them.
2	Registration rear actuator or paper eject front actuator catching on some position	Correct catching of the registration rear actuator or paper eject front actuator.
3	Eject front sensor PCB failure (Error code 84)	Check the sensor performance following the procedure described in "Function code 32". If any problem occurs, replace the eject front sensor PCB ASSY.
	Registration front/rear sensor PCB failure (Error code 88)	Check the sensor performance following the procedure described in "Function code 32". If any problem occurs, replace the registration front/rear sensor PCB ASSY.
4	HVPS control PCB failure	Replace the HVPS control PCB ASSY.
5	Engine PCB failure	Replace the engine PCB ASSY.
6	Main PCB failure	Replace the main PCB ASSY.

■ **Error code 8A**

**Jam Tray 1**  
**Remove the jammed paper from Tray 1, then press Go.**

Paper jam in the paper tray (The registration front sensor sticks at ON.)

**<User Check>**

- Check if the paper is jammed in the paper tray. If jammed, remove it.
- Adjust the paper guide corresponding to the paper size.
- Check if too much paper is loaded in the tray.

Step	Cause	Remedy
1	Harness connection failure of registration front/rear sensor PCB ASSY	Check the harness connection of the registration front/rear sensor PCB ASSY and reconnect it.
2	Paper feeding kit worn out	Replace the paper feeding kit.
3	Registration front/rear sensor PCB failure	Check the sensor performance following the procedure described in "Function code 32". If any problem occurs, replace the registration front/rear sensor PCB ASSY.
4	HVPS control PCB failure	Replace the HVPS control PCB ASSY.
5	Main PCB failure	Replace the main PCB ASSY.

■ **Error code 8D**

**Cover is Open**  
**Make sure there is no paper jammed inside the machine and close the Back Cover, then press Go.**

Eject front sensor sticking at ON upon startup

**<User Check>**

- Close the fuser cover.

Step	Cause	Remedy
1	Harness connection failure of eject front sensor PCB ASSY	Check the harness connection of the eject front sensor PCB ASSY and reconnect it.
2	Eject front sensor PCB failure	Replace the eject front sensor PCB ASSY.
3	Main PCB failure	Replace the main PCB ASSY.



## ■ Error code 8E

**Registration**  
**Registration failed. Press Go, and try again.**

Error in the adjustment of color registration result when implementing it from the control panel cover ASSY.

## Error code 8F

**Registration**  
**Registration failed. See Troubleshooting chapter in User's Guide.**

Detection of abnormal value of registration sensor sensitivity when implementing adjustment of color registration from the control panel cover ASSY.

## Error code 9D

**Registration**  
**Registration failed. See Troubleshooting chapter in User's Guide.**

Detection of incorrect registration sensor measurement value when implementing adjustment of color registration from the control panel cover ASSY.

### <User Check>

- Check if there is a scratch, dirt or the like on the belt unit. If there is, replace the belt unit with a new one.

Step	Cause	Remedy
1	Harness connection failure of registration mark PCB ASSY	Check the harness connection of the registration mark PCB ASSY and reconnect it.
2	HVPS control PCB failure	Replace the HVPS control PCB ASSY.
3	High-voltage power supply PCB failure	Replace the high-voltage power supply PCB ASSY.
4	Main PCB failure	Replace the main PCB ASSY.
5	Registration mark PCB failure	Replace the registration sensor holder ASSY.

## ■ Error code 91

**Size Mismatch**  
**Load <size> paper and press Go.**

Incorrect paper size (The paper size of the tray and that of the data are not matched.)

### <User Check>

- Check the paper size to be supported and load the appropriate size of paper.

■ **Error code 94**

**No Paper**  
**Load <size> paper, then press Go.**

- No paper in paper tray  
 (The registration front actuator is not turned ON after a certain period of time has passed.)
- Paper tray is not installed into the machine.

**<User Check>**

- Insert the paper into the paper tray.
- Remount the paper tray to the machine.

Step	Cause	Remedy
1	Lift arm and roller holder ASSY not assembled correctly	Be sure to put the boss of the roller holder ASSY into the hole on the lift arm securely.
2	Harness connection failure of registration front/rear sensor PCB ASSY	Check the harness connection of the registration front/rear sensor PCB ASSY and reconnect it.
3	Plate-up function malfunction	Replace the paper tray.
4	Registration front sensor failure	Check the sensor performance following the procedure described in "Function code 32". If any problem occurs, replace the registration front/rear sensor PCB ASSY.
5	HVPS control PCB failure	Replace the HVPS control PCB ASSY.
6	Main PCB failure	Replace the main PCB ASSY.

■ **Error code 96**

**No Paper**  
**Load <size> paper in Tray.**

No paper in all trays

(The manual paper actuator is not ON, and the registration front actuator is not turned ON after a certain period of time has passed.)

**<User Check>**

- Load the paper into any of the trays.

■ **Error code 97**

**Size Error**  
**Specify the correct paper size for Tray 1.**

Not supported paper

**<User Check>**

- Load paper with the size supported by the product.

■ **Error code 9A**

**Manual Feed**  
**Load <size> Paper.**

No paper in manual feed slot (The manual paper actuator is not turned ON.)

**Drum Cleaning**  
**Insert the blank paper into the Manual feed slot.**

No paper is inserted on the manual feed slot when drum cleaning is executed.  
 (The manual paper actuator is not turned ON.)

**<User Check>**

- Insert a paper into the manual feed slot.

Step	Cause	Remedy
1	Harness connection failure of manual sensor PCB ASSY	Check the harness connection of the manual sensor PCB ASSY and reconnect it.
2	Manual sensor failure	Check the sensor performance following the procedure described in "Function code 32". If any problem occurs, replace the manual sensor PCB ASSY.
3	Registration front/rear sensor PCB failure	Replace the registration front/rear sensor PCB ASSY.
4	HVPS control PCB failure	Replace the HVPS control PCB ASSY.
5	Main PCB failure	Replace the main PCB ASSY.

■ **Error code 9F**

**No Paper**  
**Reload paper, then press Go.**

No paper while printing

**<User Check>**

- Load the paper into the paper tray.

■ **Error code A1**

**Cover is Open**  
**Close the Top Cover.**

Top cover opened (The top cover open switch sticks at OFF.)

**<User Check>**

- Close the top cover.

Step	Cause	Remedy
1	Harness connection failure of top cover switch ASSY	Check the harness connection of the top cover switch ASSY and reconnect it.
2	The member to press the top cover switch at the right side of the inside of the top cover is broken.	Replace the top cover sub ASSY.
3	HVPS control PCB failure	Replace the HVPS control PCB ASSY.
4	Main PCB failure	Replace the main PCB ASSY.

■ **Error code C0 (K)**

**Cartridge Error**  
**Put the Black (K) Toner Cartridge back in.**

Identification failure for a new toner cartridge (K) (The new toner sensor sticks at ON.)

**Error code C1 (Y)**

**Cartridge Error**  
**Put the Yellow (Y) Toner Cartridge back in.**

Identification failure for a new toner cartridge (Y) (The new toner sensor sticks at ON.)

**Error code C2 (M)**

**Cartridge Error**  
**Put the Magenta (M) Toner Cartridge back in.**

Identification failure for a new toner cartridge (M) (The new toner sensor sticks at ON.)

**Error code C3 (C)**

**Cartridge Error**  
**Put the Cyan (C) Toner Cartridge back in.**

Identification failure for a new toner cartridge (C) (The new toner sensor sticks at ON.)

**<User Check>**

- Install the toner cartridges into the machine properly.

Step	Cause	Remedy
1	Power off or top cover opened while detecting a new toner cartridge	Reset the developing bias voltage and develop roller counter. (Refer to "2.2 Develop Roller Counter Reset Function" in Chapter 7.)
2	Toner/new sensor failure	Replace the toner/new sensor PCB ASSY.
3	Main PCB failure	Replace the main PCB ASSY.

■ **Error code C6**

**Toner Error**  
**One or more Toner Cartridges are not detected. Pull out and reinsert all 4 Toner Cartridges.**

Pressure engagement/disengagement failure of toner cartridge (Develop release sensor output error)

Step	Cause	Remedy
1	Harness connection failure of develop release motor	Check the harness connection of the develop release motor and reconnect it.
2	Harness connection failure of develop release sensor PCB ASSY	Check the harness connection of the develop release sensor PCB ASSY and reconnect it.
3	Develop release motor failure	Replace the develop release motor ASSY.
4	Develop release sensor PCB failure	Replace the develop release sensor PCB ASSY.
5	Engine PCB failure	Replace the engine PCB ASSY.
6	HVPS control PCB failure	Replace the HVPS control PCB ASSY.
7	Main PCB failure	Replace the main PCB ASSY.

■ **Error code C7**

**Out of Memory**  
**Add more Memory.**

Insufficient memory

**<User Check>**

- Install additional DIMM memory.
- Make a print by dividing data.

■ **Error code C8**

**Out of Memory**  
**Secure Print Data is full. Press Cancel and delete the previously stored data.**

RAM area for secure data full

**<User Check>**

- Delete the stored data.

Step	Cause	Remedy
1	Main PCB failure	Replace the main PCB ASSY.

■ **Error code C9**

**DIMM Error**  
**Make sure that the DIMM is inserted correctly.**

DIMM error

**<User Check>**

- Check if the DIMM is installed correctly.
- Replace the DIMM with a new one.

■ **Error code CA**

**Unusable Device**  
**Remove the Device. Turn the power off and back on again.**

Excess current to USB device

**<User Check>**

- Remove the USB device from the USB direct interface and turn the power off. Turn it on again after a while.
- Replace the USB device with other one.

Step	Cause	Remedy
1	Harness connection failure of USB direct interface relay PCB ASSY	Check the harness connection of the USB direct interface relay PCB ASSY and reconnect it.
2	USB direct interface relay PCB failure	Replace the USB direct interface relay PCB ASSY.
3	Main PCB failure	Replace the main PCB ASSY.

■ **Error code CB**

**No Belt Unit**  
**Open the Top Cover, pull out all 4 Drum Units completely and install the Belt Unit.**

Belt unit is not installed into the machine.  
 (The density sensor detects that the belt unit is not installed.)

**<User Check>**

- Check if the belt unit is installed into the machine.

Step	Cause	Remedy
1	Harness connection failure of registration mark L PCB ASSY	Check the harness connection of the registration mark L PCB ASSY and reconnect it.
2	Harness connection failure of shutter solenoid of the density sensor	Check the harness connection of shutter solenoid of the density sensor and reconnect it.
3	Engine PCB failure	Replace the engine PCB ASSY.
4	Main PCB failure	Replace the main PCB ASSY.
5	Registration mark L PCB failure	Replace the registration sensor holder ASSY.

■ **Error code CE**

**No Waste Toner**  
**Install the Waste Toner Box. Refer to the User's Guide for instructions.**

Waste toner box is not installed into the machine.  
 (It is detected by turning ON and OFF the waste toner sensor using a shutter.)

**<User Check>**

- Check if the waste toner box is installed into the machine.
- Replace the waste toner box with a new one.

Step	Cause	Remedy
1	Harness connection failure of waste toner sensor	Check the harness connection of the waste toner sensor and reconnect it.
2	HVPS control PCB failure	Replace the HVPS control PCB ASSY.
3	Main PCB failure	Replace the main PCB ASSY.



■ **Error code CF**

**Replace WT Box**  
**Replace the Waste Toner Box. Refer to the User's Guide for instructions.**

Waste toner box full (500 pages are printed after the waste toner sensor sticks at ON.)

**Note:**

The same message appears in the case of the error code F4.

**<User Check>**

- Replace the waste toner box with a new one.

Step	Cause	Remedy
1	Harness connection failure of waste toner sensor	Check the harness connection of the waste toner sensor and reconnect it.
2	Waste toner sensor failure	Check the sensor performance following the procedure described in "Function code 32". If any problem occurs, replace the waste toner sensor.
3	HVPS control PCB failure	Replace the HVPS control PCB ASSY.
4	Main PCB failure	Replace the main PCB ASSY.

■ **Error code DE**

**Print Unable DE**  
**Turn the power off and then back on again.**

The connector of the fuser unit thermistor is inserted incorrectly. (It is detected that the edge temperature is lower than 60°C.)

Step	Cause	Remedy
1	Connection failure of fuser unit thermistor connector	Check the connection of the fuser unit thermistor connector and reconnect it.
2	Fuser unit failure	Replace the fuser unit.

■ **Error code E0**

**Print Unable E0**  
**Turn the power off and then back on again.**

Program error

**<User Check>**

- Turn the power off and on.

■ **Error code E1**

**Print Unable E1**  
**Turn off and on.**

Program error

**<User Check>**

- Turn the power off and on.

Step	Cause	Remedy
1	Main PCB failure	Replace the main PCB ASSY.

■ **Error code E2**

**Print Unable E2**  
**Turn the power off and then back on again.**

Temperature error of heat roller (It is detected that the edge temperature is higher than 280°C.)

Step	Cause	Remedy
1	Fuser unit failure	Replace the fuser unit.
2	Eject front sensor PCB failure	Replace the eject front sensor PCB ASSY.
3	Main PCB failure	Replace the main PCB ASSY.

■ **Error code E3**

**Print Unable E3**  
**Turn the power off and then back on again.**

Drum motor origin sensor failure

Step	Cause	Remedy
1	Drum motor origin sensor PCB failure	Replace the drum motor origin sensor PCB ASSY.
2	Engine PCB failure	Replace the engine PCB ASSY.
3	Main PCB failure	Replace the main PCB ASSY.

■ **Error code E9**

**Print Unable E9**  
**Turn the power off and then back on again.**

Maintenance monitor error (The engine software detects an incorrect setting value.)

Step	Cause	Remedy
1	Harness connection failure of engine PCB ASSY	Check the harness connection between the main PCB ASSY and engine PCB ASSY, and reconnect it.
2	Engine PCB failure	Replace the engine PCB ASSY.
3	Main PCB failure	Replace the main PCB ASSY.

■ **Error code EC**

**Print Unable EC**  
**Turn the power off and then back on again.**

Main fan error (The engine PCB controls the rotation of the main fan.)

Step	Cause	Remedy
1	Connection failure of main fan connector	Check the connection of the main fan connector and reconnect it.
2	Main fan failure	Replace the main fan ASSY.
3	HVPS control PCB failure	Replace the HVPS control PCB ASSY.
4	High-voltage power supply PCB failure	Replace the high-voltage power supply PCB ASSY.
5	Engine PCB failure	Replace the engine PCB ASSY.
6	Main PCB failure	Replace the main PCB ASSY.

■ **Error code EF**

**Print Unable EF**  
**Turn the power off and then back on again.**

Low-voltage power supply PCB failure

(It is detected that the average coverage value suddenly becomes 0 %.)

**<User Check>**

- Turn the power off. Turn it on again after a while.

Step	Cause	Remedy
1	Low-voltage power supply PCB failure	Replace the low-voltage power supply PCB ASSY.
2	Main PCB failure	Replace the main PCB ASSY.

■ **Error code F2**

**WT Box End Soon**

The waste toner box near full.  
(Cleaning high voltage discharge due to reaching the life of the cleaning roller)

**Note:**

The same message appears in the case of the error code 5F.

**<User Check>**

- Prepare a new waste toner box.

Step	Cause	Remedy
1	HVPS control PCB failure	Replace the HVPS control PCB ASSY.
2	Engine PCB failure	Replace the engine PCB ASSY.

■ **Error code F4**

**Replace WT Box**  
**Replace the Waste Toner Box. Refer to the User's Guide for instructions.**

Waste toner box full.  
(Overcurrent flows to the cleaning roller due to the end of life of the cleaning roller.)

**Note:**

The same message appears in the case of the error code CF.

**<User Check>**

- Replace the waste toner box with a new one.

Step	Cause	Remedy
1	HVPS control PCB failure	Replace the HVPS control PCB ASSY.
2	Engine PCB failure	Replace the engine PCB ASSY.

■ **Error code F9**

**Machine Error F9**

Power turned OFF while the function code 74 is being executed and "PARAMETER INT" is being displayed

Step	Cause	Remedy
1	Incorrect operation when setting EEPROM customize code	Re-enter the EEPROM customize code.

■ Error code FA (K), FB (C), FC (M), FD (Y)

<p><b>No Toner</b>  <b>Open the Top Cover, then install Toner Cartridge. Black (K)</b></p>
<p><b>No Toner</b>  <b>Open the Top Cover, then install Toner Cartridge. Cyan (C)</b></p>
<p><b>No Toner</b>  <b>Open the Top Cover, then install Toner Cartridge. Magenta (M)</b></p>
<p><b>No Toner</b>  <b>Open the Top Cover, then install Toner Cartridge. Yellow (Y)</b></p>

The drum unit is not installed in the machine body of the product.  
 (No conduction on the drum electrode)

<User Check>

- Check if the drum unit of the appropriate color is installed in the machine body of the product.

Step	Cause	Remedy
1	Bend of electrode contact of main body	Correct the bend of the electrode contact of the main body.
2	Dirt on electrodes of main body	Clean the electrodes of the main body. (Refer to <a href="#">Fig. 3-6 (P3-33)</a> )
3	HVPS control PCB failure	Replace the HVPS control PCB ASSY.
4	High-voltage power supply PCB failure	Replace the high-voltage power supply PCB ASSY.
5	Engine PCB failure	Replace the engine PCB ASSY.

■ **Error code FE**

-
---

Detection of incorrect measurement value of density sensor sensitivity calibration

**<User Check>**

- Check if the 4-color drum units are properly installed in the product.

Step	Cause	Remedy
1	Belt unit failure	Replace the belt unit.
2	Harness connection failure of registration mark L PCB ASSY	Check the harness connection of the registration mark L PCB ASSY and reconnect it.
3	Registration mark relay PCB failure	Replace the registration mark relay PCB ASSY.
4	Main PCB failure	Replace the main PCB ASSY.
5	Registration mark L PCB failure	Replace the registration sensor holder ASSY.

■ **Error code FF**

<p><b>Unusable Device</b>  <b>Remove the Device. Turn the power off and back on again.</b></p>
--

Overcurrent error of wireless LAN PCB

Step	Cause	Remedy
1	Wireless LAN PCB failure	Replace the wireless LAN PCB ASSY.
2	Main PCB failure	Replace the main PCB ASSY.

### 3. PAPER FEEDING PROBLEMS

Problems related to paper feeding are end user recoverable if following the User Check items. If the same problem occurs again, follow each procedure in the order of the number described in the Step column in the tables below.

#### 3.1 No Feeding

**<User Check>**

- Check if the paper is loaded into the paper tray correctly.
- Turn over the stack of paper in the paper tray, or try rotating the paper 180° in the paper tray.
- Check if the thickness of the paper is 75 to 105g/m<sup>2</sup>.

Step	Cause	Check	Result	Remedy
1	Paper pick-up roller worn out	Is the paper pick-up roller worn out?	Yes	Replace the roller holder ASSY.
2	Plate gear damaged	Is the plate gear damaged?	Yes	Replace the paper tray.
3	Registration front actuator malfunction	Does the registration front actuator move smoothly?	No	Re-assemble the registration front actuator.
4	Disconnection of the pick-up solenoid harness	Is the harness of the pick-up solenoid disconnected?	Yes	Reconnect the harness of the pick-up solenoid.
5	Registration front/rear sensor PCB failure	Is the problem solved by replacing the registration front/rear sensor PCB ASSY?	Yes	Replace the registration front/rear sensor PCB ASSY.
6	Pick-up solenoid failure	Does the pick-up solenoid move correctly?	No	Replace the pick-up solenoid.
7	Paper feed motor failure	Is the problem solved by replacing the paper feed motor ASSY?	Yes	Replace the paper feed motor ASSY.
8	Engine PCB failure	Is the problem solved by replacing the engine PCB ASSY?	Yes	Replace the engine PCB ASSY.

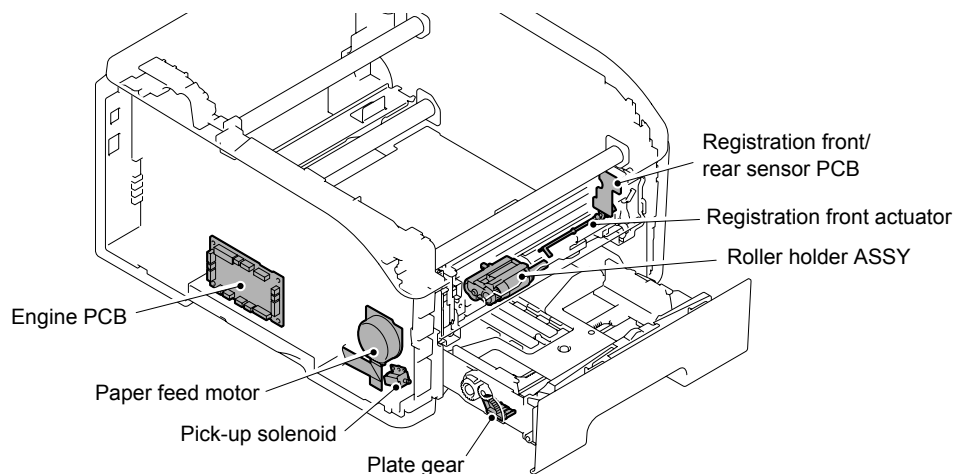

**Fig. 3-7**

## 3.2 Double Feeding

### <User Check>

- Check if the paper is loaded into the paper tray correctly.
- Turn over the stack of paper in the paper tray, or try rotating the paper 180° in the paper tray.
- Check if the thickness of the paper is 75 to 105g/m<sup>2</sup>.
- Set out papers and reload them into the paper tray.

Step	Cause	Check	Result	Remedy
1	Separation pad or separation roller worn out	Is the surface of the separation pad or separation roller worn out?	Yes	Replace the paper feeding kit.

## 3.3 Paper Jam

### <User Check>

- Check if the paper is loaded into the paper tray correctly.
- Turn over the stack of paper in the paper tray, or try rotating the paper 180° in the paper tray.
- Check if the thickness of the paper is 75 to 105g/m<sup>2</sup>.

### ■ Paper jam in the paper tray and front section

Step	Cause	Check	Result	Remedy
1	Foreign object around front section	Is there a foreign object around the front section?	Yes	Remove the foreign object.
2	Belt unit malfunction	Does the belt unit move correctly?	No	Replace the belt unit.
3	Registration front actuator catching on some position	Does the registration front actuator move smoothly?	No	Re-assemble the registration front actuator.
4	Registration rear actuator catching on some position	Does the registration rear actuator move smoothly?	No	Re-assemble the registration rear actuator.
5	Registration front/rear sensor PCB failure	Does the registration front/rear sensor move smoothly? (Check it following the procedure described in "Function code 32".)	No	Replace the registration front/rear sensor PCB ASSY.



■ Paper jam in the back cover and paper eject section

Step	Cause	Check	Result	Remedy
1	Foreign object around fuser unit	Is there a foreign object around the fuser unit?	Yes	Remove the foreign object.
2	Paper eject rear actuator top failure	Does the paper eject rear actuator top move smoothly? Is it damaged?	No	Replace the paper eject rear actuator top.
3	Paper eject front actuator failure	Does the paper eject front actuator move smoothly? Is it damaged?	No	Replace the paper eject front actuator.
4	Paper eject rear actuator failure	Does the paper eject rear actuator move smoothly? Is it damaged?	No	Replace the fuser unit.
5	Eject front sensor PCB failure	Is the problem solved by replacing the eject front sensor PCB ASSY?	Yes	Replace the eject front sensor PCB ASSY.
6	Eject rear sensor PCB failure	Is the problem solved by replacing the eject rear sensor PCB ASSY?	Yes	Replace the eject rear sensor PCB ASSY.

## 3.4 Dirt on Paper

### <User Check>

- Check if the paper is loaded into the paper tray correctly.
- Turn over the stack of paper in the paper tray, or try rotating the paper 180° in the paper tray.
- Replace the waste toner box with a new one.

Step	Cause	Check	Result	Remedy
1	Fuser unit dirty	Is there dirt around the entrance of the fuser unit?	Yes	Clean the entrance of the fuser unit.
		Is the pressure roller dirty?	Yes	Clean the pressure roller.
2	Dirt in the paper feed system	Is the paper tray or feed system on the drum unit dirty with toner?	Yes	Wipe dirt off.
3	Belt unit dirty	Does dirt on the paper disappear after replacing the belt unit with a new one?	Yes	Replace the belt unit.
4	Waste toner sensor failure	Is the waste toner box full of toner?	No	Replace the waste toner sensor.
5	Main PCB failure	Is the problem solved after replacing the main PCB ASSY?	Yes	Replace the main PCB ASSY.

## 3.5 Wrinkles on Paper

### <User Check>

- Check if the paper is loaded into the paper tray correctly.
- Turn over the stack of paper in the paper tray, or try rotating the paper 180° in the paper tray.
- Check if the thickness of the paper is 75 to 105g/m<sup>2</sup>.

Step	Cause	Check	Result	Remedy
1	Fuser unit failure	Do wrinkles on the paper disappear after replacing the fuser unit with a new one?	Yes	Replace the fuser unit.

# 3.6 Curl of Paper

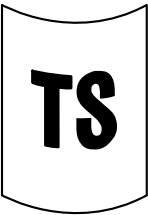

**<User Check>**

- Change the curl improvement mode setting of the driver.
- Switch the delivery roller switch lever.

**Note:**  
Be sure not set the curl improvement mode of the driver and switch to the delivery roller switch lever at the same time because it might worsen the level of curl.

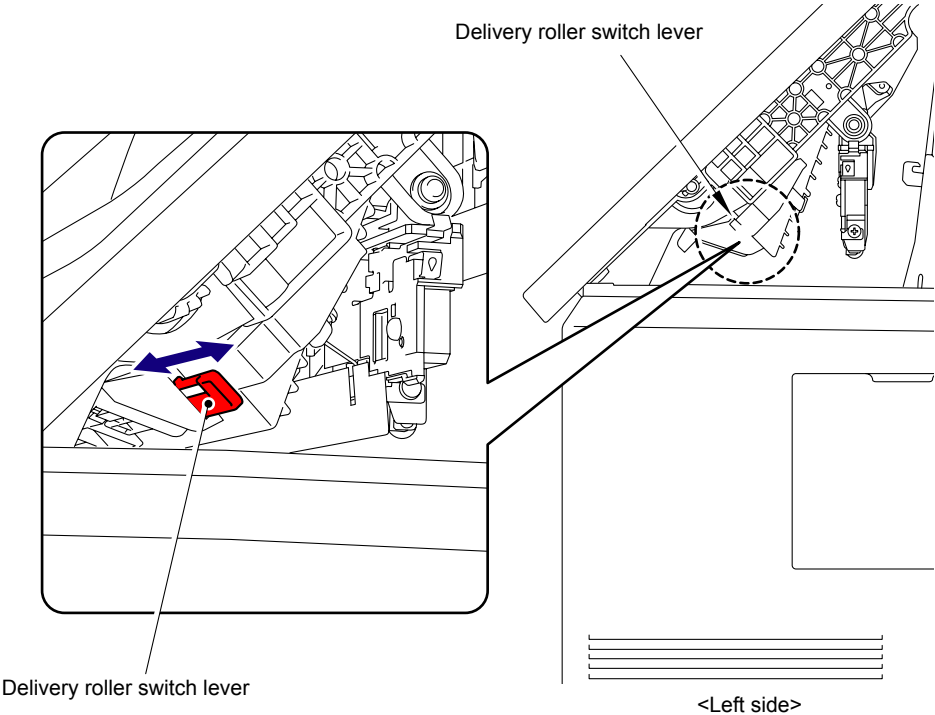

**Fig. 3-8**

# 4. IMAGE DEFECT TROUBLESHOOTING

## 4.1 Image Defect Examples

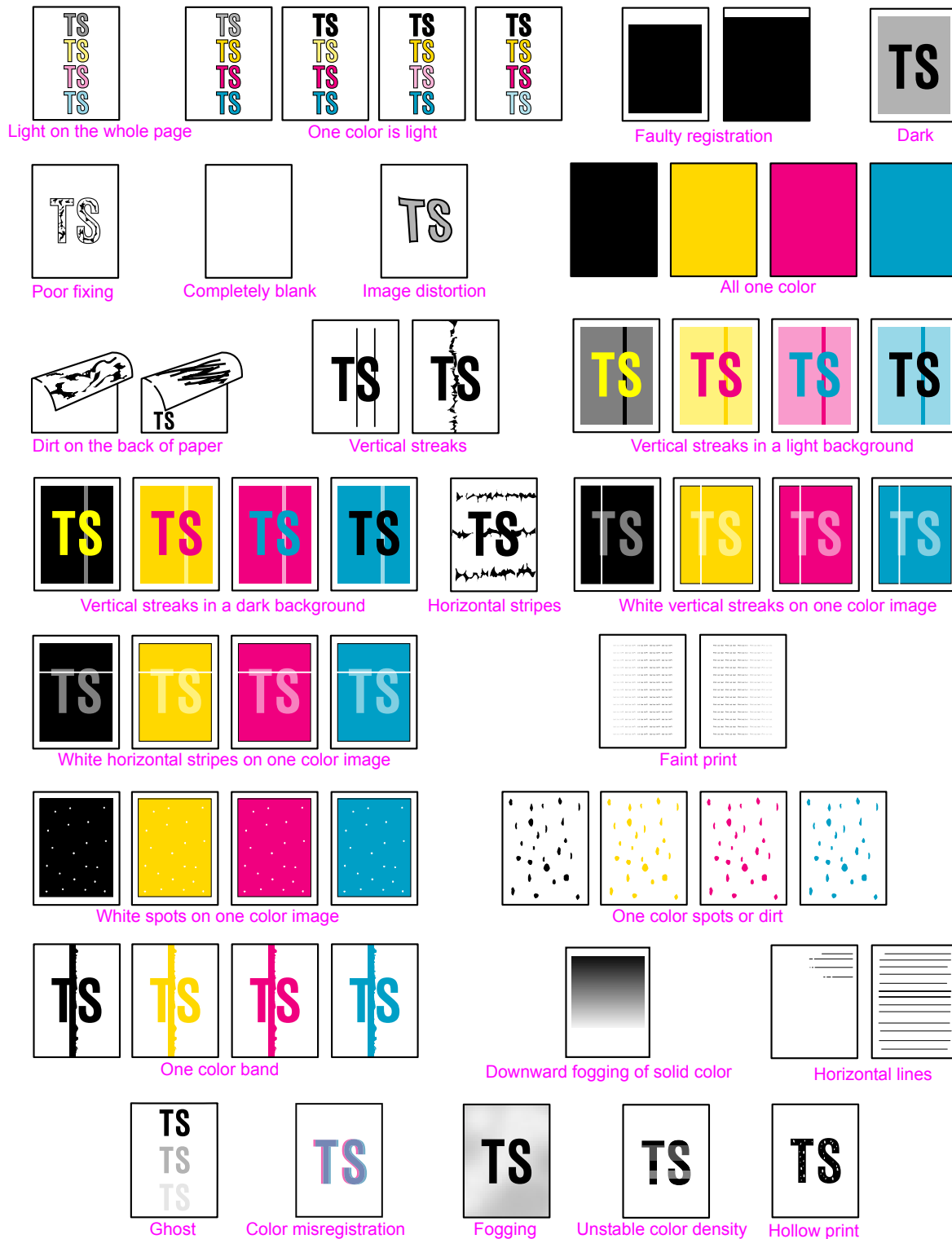

Fig. 3-9

## 4.2 Pitch Indicated in Roller Image

Image defects which occur periodically may be caused by a failure of the roller. By referring to the table below, specify the cause based on the pitch indicated in the image of each roller.

No.	Parts name	The pitch which appears in the image
1	Develop roller	31 mm
2	Exposure drum	94 mm
3	Heat roller in the fuser unit	78 mm
4	Pressure roller in the fuser unit	78 mm

## 4.3 Troubleshooting Image Defect

Image defect related problems are user recoverable if following the User Check items. If the same problem occurs, follow each procedure in the order of the number described in the Step column in the tables below.

### ■ Light on the whole page



#### <User Check>

- Check the machine's environment. High temperature and high humidity or low temperature and low humidity conditions can cause this problem.
- If the whole page is light, toner save mode may be on. Turn off the toner save mode.
- Replace the toner cartridge or drum unit with a new one.
- Adjust the color density from the control panel cover ASSY.
- Leave the machine for a while as the power remains ON.

Step	Cause	Check	Result	Remedy
1	HVPS control PCB failure	Is the problem solved after replacing the HVPS control PCB ASSY?	Yes	Replace the HVPS control PCB ASSY.
2	High-voltage power supply PCB failure	Is the problem solved after replacing the high-voltage power supply PCB ASSY?	Yes	Replace the high-voltage power supply PCB ASSY.
3	Engine PCB failure	Is the problem solved after replacing the engine PCB ASSY?	Yes	Replace the engine PCB ASSY.
4	Main PCB failure	Is the problem solved after replacing the main PCB ASSY?	Yes	Replace the main PCB ASSY.
5	LED head control PCB failure	Is the problem solved after replacing the LED head control PCB ASSY?	Yes	Replace the LED head control PCB ASSY.
6	LED ASSY failure	Is the problem solved after replacing the LED ASSY?	Yes	Replace the LED ASSY.
7	Registration mark L PCB failure	Is the problem solved after replacing the registration sensor holder ASSY?	Yes	Replace the registration sensor holder ASSY.

■ One color is light

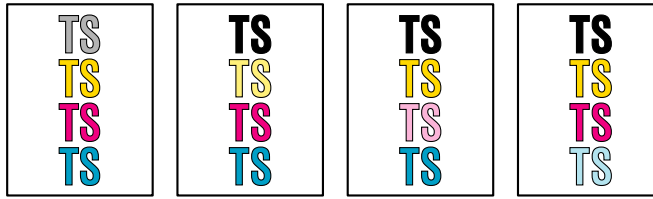

<User Check>

- Open and close the top cover and make print again.
- Check the machine's environment. High temperature and high humidity or low temperature and low humidity conditions can cause this problem.
- Replace the toner cartridge or drum unit with a new one.
- Adjust the color density from the control panel cover ASSY.

Step	Cause	Check	Result	Remedy
1	Dirt on exposure drum electrode	Are the electrodes on the drum unit of the appropriate color and machine body dirty?	Yes	Clean both electrodes. (Refer to Fig. 3-3 (P3-32) and Fig. 3-6 (P3-33))
2	Dirt on develop roller electrode	Are the electrodes on the develop roller of the appropriate color and machine body dirty?	Yes	Clean both electrodes. (Refer to Fig. 3-3 (P3-32) and Fig. 3-6 (P3-33))
3	Dirt on belt unit electrode	Are the electrodes on the belt unit of the appropriate color and machine body dirty?	Yes	Clean both electrodes. (Refer to Fig. 3-4 (P3-32) and Fig. 3-6 (P3-33))
4	Dirt on LED array	Is the LED array of the appropriate color dirty?	Yes	Wipe the dirt off with a clean, soft, and lint-free cloth.
5	Lifting of LED ASSY	Is printing of the LED ASSY test pattern correctly done in "Function code 68"?	No	Re-assemble the LED ASSY.
6	Toner/new sensor PCB failure	After replacing the toner cartridge of the appropriate color with a new one, does the same problem occur even after printing several pages?	No	Replace the toner cartridge of the appropriate color.
7		Does the machine start printing even after removing the toner cartridge of the appropriate color from the drum unit?	Yes	<ul style="list-style-type: none"> <li>- Check the harness connection of the toner/new sensor PCB ASSY of the appropriate color.</li> <li>- Replace the toner/new sensor PCB ASSY of the appropriate color.</li> </ul>

Step	Cause	Check	Result	Remedy
8	HVPS control PCB failure	Is the problem solved after replacing the HVPS control PCB ASSY?	Yes	Replace the HVPS control PCB ASSY.
9	High-voltage power supply PCB failure	Is the problem solved after replacing the high-voltage power supply PCB ASSY?	Yes	Replace the high-voltage power supply PCB ASSY.
10	LED head control PCB failure	Is the problem solved after replacing the LED head control PCB ASSY?	Yes	Replace the LED head control PCB ASSY.
11	Main PCB failure	Is the problem solved after replacing the main PCB ASSY.	Yes	Replace the main PCB ASSY.

■ **Faulty registration**

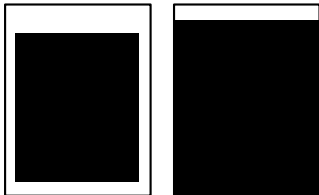

Step	Cause	Check	Result	Remedy
1	Registration rear actuator catching on some position	Does the registration rear actuator move smoothly?	No	Correct catching of the registration rear actuator.
2	HVPS control PCB failure	Is the problem solved after replacing the HVPS control PCB ASSY?	Yes	Replace the HVPS control PCB ASSY.
3	Main PCB failure	Is the problem solved after replacing the main PCB ASSY?	Yes	Replace the main PCB ASSY.

■ Dark



<User Check>

- Check the machine's environment. High temperature and high humidity or low temperature and low humidity conditions can cause this problem.
- Clean the corona wire.
- Replace the toner cartridge or drum unit with a new one.
- Adjust the color density from the control panel cover ASSY.

Step	Cause	Check	Result	Remedy
1	Corona wire conduction failure	Are the electrodes on the drum unit and machine body dirty?	Yes	Clean both electrodes. (Refer to Fig. 3-3 (P3-32) and Fig. 3-6 (P3-33))
2	Dirt on belt unit electrode	Are the electrodes on the belt unit and machine body dirty?	Yes	Clean both electrodes. (Refer to Fig. 3-4 (P3-32) and Fig. 3-6 (P3-33))
3	HVPS control PCB failure	Is the problem solved after replacing the HVPS control PCB ASSY?	Yes	Replace the HVPS control PCB ASSY.
4	High-voltage power supply PCB failure	Is the problem solved after replacing the high-voltage power supply PCB ASSY?	Yes	Replace the high-voltage power supply PCB ASSY.
5	Engine PCB failure	Is the problem solved after replacing the engine PCB ASSY?	Yes	Replace the engine PCB ASSY.
6	Main PCB failure	Is the problem solved after replacing the main PCB ASSY?	Yes	Replace the main PCB ASSY.
7	LED head control PCB failure	Is the problem solved after replacing the LED head control PCB ASSY?	Yes	Replace the LED head control PCB ASSY.
8	Registration mark L PCB failure	Is the problem solved after replacing the registration sensor holder ASSY?	Yes	Replace the registration sensor holder ASSY.
9	Toner/new sensor PCB failure	Is the problem solved after replacing the toner/new sensor PCB ASSY?	Yes	Replace the toner/new sensor PCB ASSY.



## ■ Poor fixing

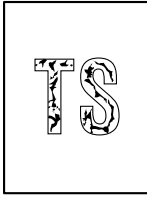

### <User Check>

- Open and close the top cover and make print again.
- Adjust the color density from the control panel cover ASSY.
- Check the machine's environment. High temperature and high humidity or low temperature and low humidity conditions can cause this problem.
- Replace the belt unit with a new one.
- Replace the drum unit with a new one.
- Replace the toner cartridge with a new one.

### Memo:

You can check this image defect with the function code 71.  
(Refer to "1.4.14 Color test pattern (Function code 71)" in Chapter 7.)

Step	Cause	Check	Result	Remedy
1	Lifting of LED ASSY	Is printing of the LED ASSY test pattern correctly done in "Function code 68"?	No	Re-assemble the LED ASSY.
2	Fuser unit failure	Is the problem solved after replacing the fuser unit?	Yes	Replace the fuser unit.
3	Low-voltage power supply PCB failure	Is the problem solved after replacing the low-voltage power supply PCB ASSY?	Yes	Replace the low-voltage power supply PCB ASSY.
4	HVPS control PCB failure	Is the problem solved after replacing the HVPS control PCB ASSY?	Yes	Replace the HVPS control PCB ASSY.
5	High-voltage power supply PCB failure	Is the problem solved after replacing the high-voltage power supply PCB ASSY?	Yes	Replace the high-voltage power supply PCB ASSY.
6	Engine PCB failure	Is the problem solved after replacing the engine PCB ASSY?	Yes	Replace the engine PCB ASSY.
7	Toner/new sensor PCB failure	Is the problem solved after replacing the toner/new sensor PCB ASSY?	Yes	Replace the toner/new sensor PCB ASSY.
8	Main PCB failure	Is the problem solved after replacing the main PCB?	Yes	Replace the main PCB ASSY.

## ■ Completely blank



### <User Check>

- Replace the belt unit with a new one.
- Replace the toner cartridge or drum unit with a new one.

Step	Cause	Check	Result	Remedy
1	Developing bias voltage conduction failure	Are the electrodes on the drum unit and machine body dirty?	Yes	Clean both electrodes. (Refer to Fig. 3-3 (P3-32) and Fig. 3-6 (P3-33))
2	Dirt on develop roller electrode	Are the electrodes on the develop roller and machine body dirty?	Yes	Clean both electrodes. (Refer to Fig. 3-3 (P3-32) and Fig. 3-6 (P3-33))
3	LED array FFC connection failure	Is the LED array FFC connected securely?	No	Reconnect the LED array FFC.
4	LED ASSY failure	Is the problem solved after replacing the LED ASSY?	Yes	Replace the LED ASSY.
5	HVPS control PCB failure	Is the problem solved after replacing the HVPS control PCB ASSY?	Yes	Replace the HVPS control PCB ASSY.
6	High-voltage power supply PCB failure	Is the problem solved after replacing the high-voltage power supply PCB ASSY?	Yes	Replace the high-voltage power supply PCB ASSY.
7	LED head control PCB failure	Is the problem solved after replacing the LED head control PCB ASSY?	Yes	Replace the LED head control PCB ASSY.
8	Main PCB failure	Is the problem solved after replacing the main PCB ASSY?	Yes	Replace the main PCB ASSY.

## ■ Image distortion

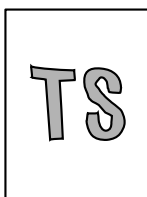

### <User Check>

- Replace the belt unit with a new one.

Step	Cause	Check	Result	Remedy
1	LED head control PCB failure	Is the problem solved after replacing the LED head control PCB ASSY?	Yes	Replace the LED head control PCB ASSY.
2	Main PCB failure	Is the problem solved after replacing the main PCB ASSY?	Yes	Replace the main PCB ASSY.

■ All one color

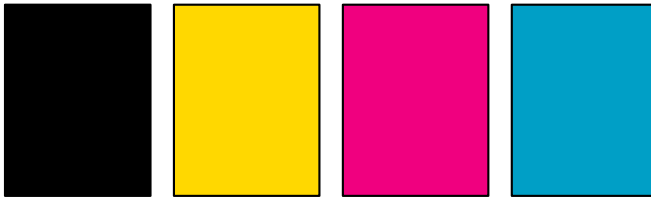

**Memo:**

You can check this image defect with the function code 71.  
 (Refer to "1.4.14 Color test pattern (Function code 71)" in Chapter 7.)

Step	Cause	Check	Result	Remedy
1	Corona wire failure	Are the electrodes on the drum unit of the appropriate color and machine body dirty?	Yes	Clean both electrodes. (Refer to Fig. 3-3 (P3-32) and Fig. 3-6 (P3-33))
2		Is the corona wire damaged?	Yes	Replace the drum unit.
3	HVPS control PCB failure	Is the problem solved after replacing the HVPS control PCB ASSY?	Yes	Replace the HVPS control PCB ASSY.
4	High-voltage power supply PCB failure	Is the problem solved after replacing the high-voltage power supply PCB ASSY?	Yes	Replace the high-voltage power supply PCB ASSY.
5	LED ASSY failure	Is the problem solved after replacing the LED ASSY?	Yes	Replace the LED ASSY.
6	LED head control PCB failure	Is the problem solved after replacing the LED head control PCB ASSY?	Yes	Replace the LED head control PCB ASSY.
7	Main PCB failure	Is the problem solved after replacing the main PCB ASSY?	Yes	Replace the main PCB ASSY.

■ **Dirt on the back of paper**

**<User Check>**

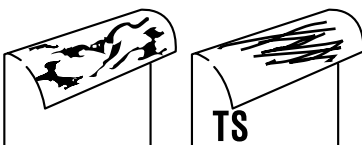

- Replace the waste toner box with a new one.
- Replace the belt unit with a new one.

Step	Cause	Check	Result	Remedy
1	Fuser unit dirty	Is the pressure roller dirty?	Yes	Print approximate 10 pages.
		Is the fuser unit dirty?	No	Replace the fuser unit.
2	Dirt in the paper feed system	Is the paper tray or feed system on the drum unit dirty with toner?	Yes	Wipe dirt off.
3	Waste toner sensor failure	Is the waste toner box full of toner?	Yes	Replace the waste toner sensor.
4	HVPS control PCB failure	Is the problem solved after replacing the HVPS control PCB ASSY?	Yes	Replace the HVPS control PCB ASSY.
5	High-voltage power supply PCB failure	Is the problem solved after replacing the high-voltage power supply PCB ASSY?	Yes	Replace the high-voltage power supply PCB ASSY.

## ■ Vertical streaks

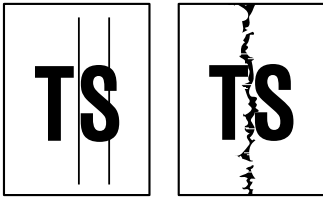

### <User Check>

- This problem may occur with noise which is caused by dirt on the corona wire in the drum unit. In this case, clean the corona wire.
- Replace the drum unit with a new one.
- Replace the toner cartridge with a new one.

### Note:

You can check this image defect with the function code 71.  
(Refer to "1.4.14 Color test pattern (Function code 71)" in Chapter 7.)

Step	Cause	Check	Result	Remedy
1	Dirt in the paper feed system	Is the paper tray or feed system on the drum unit dirty with toner?	Yes	Wipe dirt off.
2	Exposure drum dirty	Is there vertical dirt with toner on the surface of the exposure drum?	Yes	Clean the drum unit.
3	Bend of tray ground spring	Is the tray ground spring bent? (Refer to Fig. 3-10)	Yes	Replace the paper tray.
4	Scratch on the heat roller	Is there a scratch on the surface of the heat roller?	Yes	Replace the fuser unit.
5	LED ASSY failure	Is the problem solved after replacing the LED ASSY?	Yes	Replace the LED ASSY.

### Note:

If the machine prints the same pattern, especially including vertical streaks, continuously, black vertical streaks may appear on the paper since the electrostatic performance of the exposure drum is decreased temporarily.

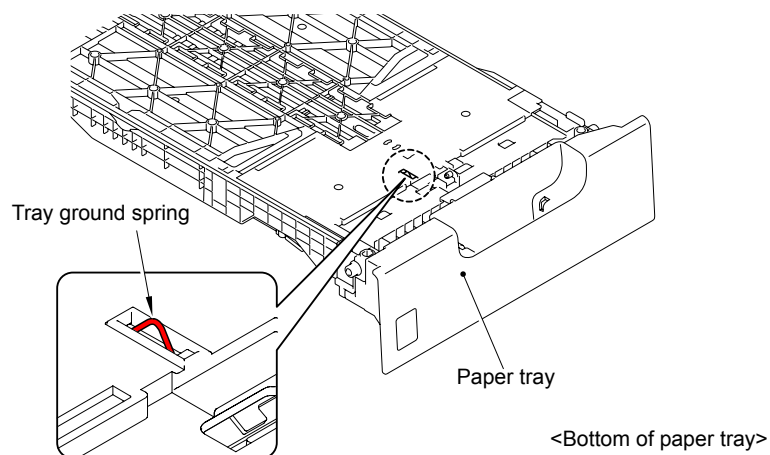
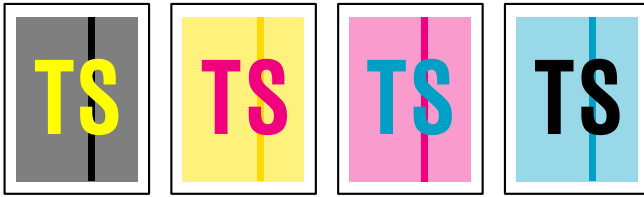

Fig. 3-10

■ **Vertical streaks in a light background**



**<User Check>**

- Clean the inside of the machine and the corona wire in the drum unit.
- Clean the LED array with a soft lint-free cloth.
- Replace the toner cartridge with a new one.
- Replace the drum unit with a new one.

**Note:**

You can check this image defect with the function code 71.  
 (Refer to "1.4.14 Color test pattern (Function code 71)" in Chapter 7.)

Step	Cause	Check	Result	Remedy
1	LED ASSY failure	Is the problem solved after replacing the LED ASSY?	Yes	Replace the LED ASSY.

■ **Vertical streaks in a dark background**

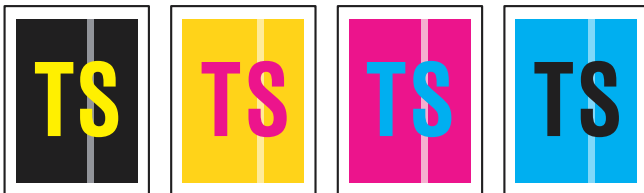

**<User Check>**

- Clean the inside of the machine and the corona wire in the drum unit.
- Clean the LED array with a soft lint-free cloth.
- Replace the toner cartridge with a new one.

Step	Cause	Check	Result	Remedy
1	LED ASSY failure	Is the problem solved after replacing the LED ASSY?	Yes	Replace the LED ASSY.

## ■ Horizontal stripes



### <User Check>

- Clean the inside of the machine and the corona wire in the drum unit.
- Replace the drum unit with a new one.

Step	Cause	Check	Result	Remedy
1	Dirt on the charged electrode	Are the electrodes on the drum unit and machine body dirty?	Yes	Clean both electrodes. (Refer to Fig. 3-3 (P3-32) and Fig. 3-6 (P3-33))
2	Bend of tray ground spring	Is the tray ground spring bent? (Refer to Fig. 3-10 (P3-65))	Yes	Replace the paper tray.
3	Toner attached on the develop roller	Are the horizontal stripes at 31 mm (develop roller circumference) intervals?	Yes	This problem will disappear by printing approximate 10 pages. If the same problem occurs, replace the toner cartridge.
4	Scratch on the heat roller	Are the horizontal stripes at 78 mm (heat roller circumference) intervals?	Yes	Replace the fuser unit.
5	HVPS control PCB failure	Is the problem solved after replacing the HVPS control PCB ASSY?	Yes	Replace the HVPS control PCB ASSY.

■ **White vertical streaks on one color image**

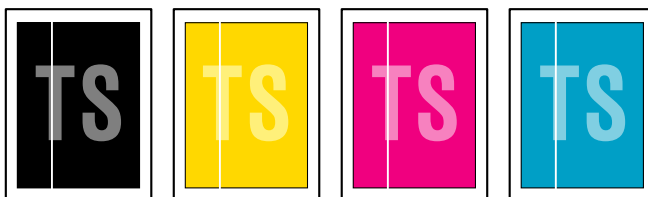

**<User Check>**

- Check if there is no dust in the gap between the toner cartridge and drum frame.
- Clean the relevant color LED array on which color loss occurs with a soft lint-free cloth.
- Replace the toner cartridge with a new one.
- Check the machine's environment. High temperature and high humidity or low temperature and low humidity conditions can cause this problem.
- Damp (wet) paper might be used. Try to change to freshly unpacked paper.
- Replace the drum unit with a new one.

Step	Cause	Check	Result	Remedy
1	Condensation	Has condensation occurred inside the machine?	Yes	Try to print several pages or leave the machine 2 hours to allow it to reach room temperature.
2	LED array failure	Is the problem solved after replacing the LED ASSY?	Yes	Replace the LED ASSY.



■ **White horizontal stripes on one color image**

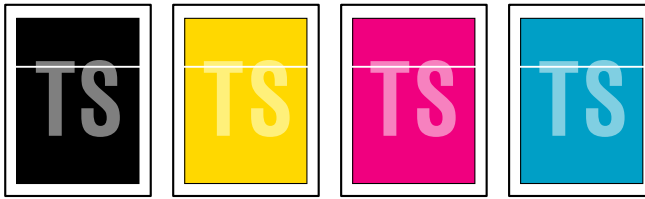

**<User Check>**

- The problem may disappear by itself. Try printing multiple pages to clear this problem especially if the machine has not been used for a long time.
- Replace the toner cartridge with a new one.
- The drum unit may be damaged. Replace the drum unit with a new one.

Step	Cause	Check	Result	Remedy
1	HVPS control PCB failure	Is the problem solved after replacing the HVPS control PCB ASSY?	Yes	Replace the HVPS control PCB ASSY.
2	High-voltage power supply PCB failure	Is the problem solved after replacing the high-voltage power supply PCB ASSY?	Yes	Replace the high-voltage power supply PCB ASSY.
3	Engine PCB failure	Is the problem solved after replacing the engine PCB ASSY?	Yes	Replace the engine PCB ASSY.

■ **Faint print**

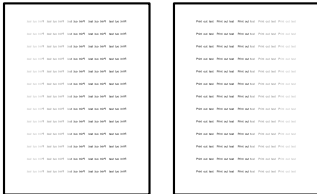

**<User Check>**

- Open and close the top cover and make print again.
- Check that the machine is installed on a level surface.
- Replace the toner cartridge with a new one.
- Clean the LED array with a soft lint-free cloth.

Step	Cause	Check	Result	Remedy
1	Lifting of LED ASSY	Is printing of the LED ASSY test pattern correctly done in "Function code 68"?	No	Re-assemble the LED ASSY.
2	Toner/new sensor PCB failure	Is the "Replace Toner" message indicated on the LCD when replacing the toner cartridge with the one which has reached the end of life?	No	Replace the toner/new sensor PCB ASSY.

■ **White spots on one color image**

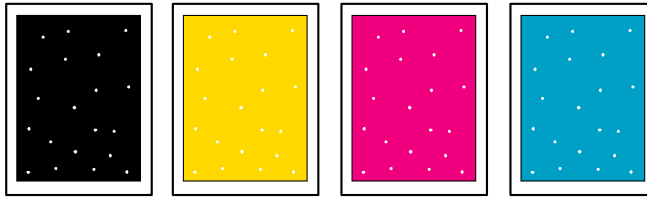

**<User Check>**

- Toner may be empty. Replace the toner cartridge with a new one.
- If the same problem occurs after printing a few pages, the adhesive of the label or the like, paper powder or dirt may be attached on the surface of the exposure drum. When the size of the white spots is less than 0.35mm, feed the paper from the manual feed slot one to three times to clean the drum. (Refer to **“Drum cleaning function of product” in the next page.**) When the size of the spots is 0.35mm or more, or when the same problem occurs after feeding the drum cleaning sheet, wipe off the dirt on the exposure drum with a cotton swab. (Refer to **“Drum unit cleaning” in this chapter.**)
- The drum unit may be damaged. Replace the drum unit with a new one.
- The belt unit may be damaged. Replace the belt unit with a new one.

Step	Cause	Check	Result	Remedy
1	Toner cartridge failure	Are the white spots at 31 mm (develop roller circumference) intervals?	Yes	If the develop roller surface is scratched, replace the toner cartridge.
2	Toner/new sensor PCB failure	Is the “Replace Toner” message indicated on the LCD when replacing the toner cartridge with the one which has reached the end of life?	No	Replace the toner/new sensor PCB ASSY.

**Note:**

If there is any problem in the print quality, be sure to clean the drum unit in accordance with “Drum cleaning function of product” provided below.

If the problem still persists, be sure to clean the drum unit manually in accordance with “Drum unit cleaning” in this chapter.

**<Drum cleaning function of product>**

- (1) Open the manual feed slot cover.

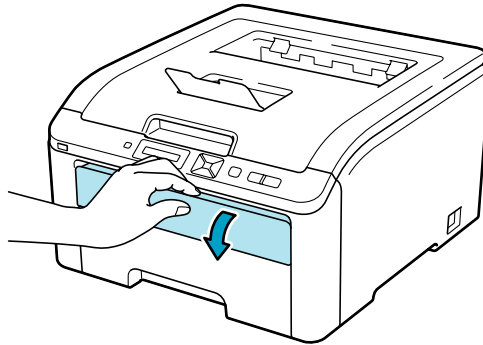

**Fig. 3-11**

- (2) Using both hands, slide the manual feed slot paper guides to the width of the paper that you are going to use.

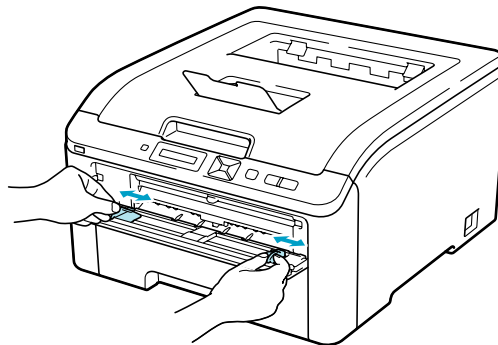

**Fig. 3-12**

- (3) Using both hands, put one piece of paper in the manual feed slot until the front edge of the paper touches the paper feed roller. Wait until the machine automatically feeds the paper. When you feel the machine pull in the paper, let go.

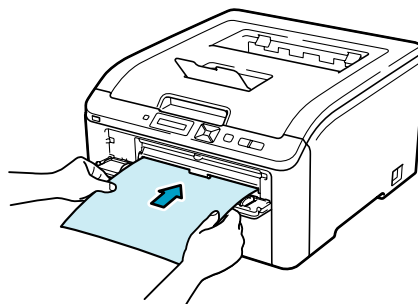

**Fig. 3-13**

**Note:**

- Make sure that the paper is straight and in the correct position on the manual feed slot. If it is not, the paper may not be fed properly, resulting in a skewed printout or a paper jam.
- Do not put more than one piece of paper in the manual feed slot at any one time, as it may cause a jam.
- If you put paper in the manual feed slot before the printer is in the ready state, an error may occur and the printer will stop printing.

- (4) Press **+** or **-** to choose “Color Correction.” Press **OK**.
- (5) Press **+** or **-** to choose “Drum Cleaning.”
- (6) Press **Go**. The printer will pull in the piece of paper and start cleaning the drum unit.



**Fig. 3-14**

- (7) When the printer has finished cleaning, “Completed” appears on the LCD. Press **Cancel** so that the printer returns to the ready state.
- (8) Repeat steps (3) to (7) two more times.

### <Drum unit cleaning>

- (1) Pull the drum unit out of the machine and take all the toner cartridges out of the drum unit.

**Note:**

We recommend that you place the drum unit on a clean, flat surface with a piece of disposable paper underneath it in case you accidentally spill or scatter toner.

- (2) See the print sample to identify the color causing the problem. The color of the spots is the color of the drum you should clean. For example, if the spots are cyan, you should clean the drum for cyan. Put the print sample in front of the drum, and find the exact position of the poor print.

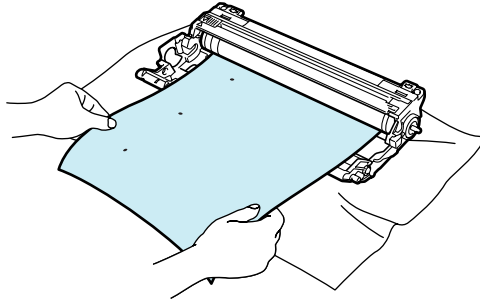

Fig. 3-15

- (3) Turn the drum unit gear to the direction of the arrow as shown in the figure below by hand while looking at the surface of the drum "1".

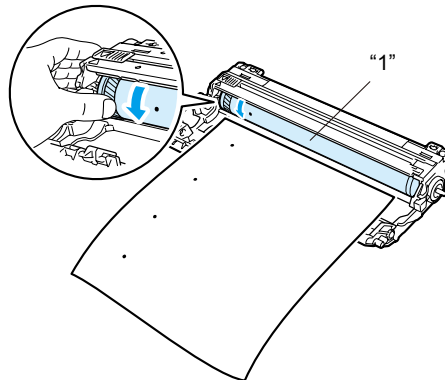

Fig. 3-16

- (4) When you have found the mark on the drum that matches the print sample, wipe the surface of the drum gently with a cotton swab until the dust or paper powder on the surface comes off.

**Note:**

DO NOT clean the surface of the photosensitive drum with a sharp object.

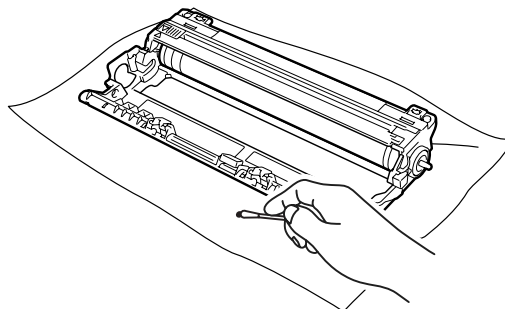
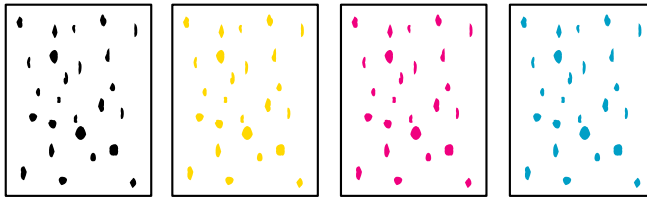

Fig. 3-17

■ One color spots or dirt



<User Check>

- Damp (wet) paper might be used. Try to changing to freshly unopened paper.
- Toner may be empty. Replace the toner cartridge with a new one.
- If the same problem occurs after printing a few pages, the adhesive of a label or the like, paper powder or dirt may be attached on the surface of the exposure drum. Feed the paper from the manual feed slot one to three times to clean the drum. (Refer to “Drum cleaning function of product” in this chapter.)  
When the same problem occurs after feeding the drum cleaning sheet, wipe off the dirt on the exposure drum with a cotton swab. (Refer to “Drum unit cleaning” in the previous pages.)
- The drum unit may be damaged. Replace the drum unit with a new one.
- The belt unit may be damaged. Replace the belt unit with a new one.

Step	Cause	Check	Result	Remedy
1	Fuser unit failure	Are the spots at 78 mm (heat roller circumference) intervals?	Yes	Replace the fuser unit.
2	Toner/new sensor PCB failure	Is the “Replace Toner” message indicated on the LCD when replacing the toner cartridge with the one which has reached the end of life?	Yes	Replace the toner/new sensor PCB ASSY.

■ One color band

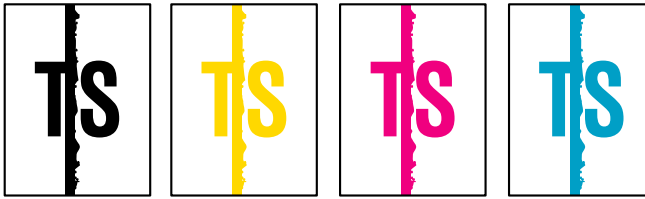

<User Check>

- Clean the inside of the machine and the corona wire in the drum unit. If the same problem occurs after cleaning, replace the drum unit with a new one.
- The paper tray ground terminal provided in the machine body may be dirty. Clean the contact with a dry cloth.

■ Downward fogging of solid color



<User Check>

- Toner may be empty. Replace the toner cartridge with a new one.

Step	Cause	Check	Result	Remedy
1	HVPS control PCB failure	Is the problem solved after replacing the HVPS control PCB ASSY?	Yes	Replace the HVPS control PCB ASSY.
2	High-voltage power supply PCB failure	Is the problem solved after replacing the high-voltage power supply PCB ASSY?	Yes	Replace the high-voltage power supply PCB ASSY.
3	Engine PCB failure	Is the problem solved after replacing the engine PCB ASSY?	Yes	Replace the engine PCB ASSY.
4	Main PCB failure	Is the problem solved after replacing the main PCB ASSY?	Yes	Replace the main PCB ASSY.

## ■ Horizontal lines

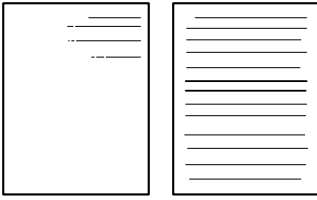

### <User Check>

- The paper tray ground terminal provided in the machine body may be dirty. Clean the contact with a dry cloth.
- Replace the drum unit with a new one.
- Replace the toner cartridge with a new one.

Step	Cause	Check	Result	Remedy
1	Dirt on charged electrode	Are the electrodes on the drum unit and machine body dirty?	Yes	Clean both electrodes. (Refer to Fig. 3-3 (P3-32) and Fig. 3-6 (P3-33))
2	Paper tray ground terminal provided in machine body	Is the paper tray ground terminal bent, which is provided in the machine body?	Yes	Correct bending of paper tray ground terminal.
3	Toner attached on the develop roller	Are the horizontal lines at 31 mm (develop roller circumference) intervals?	Yes	This symptom might disappear after making approximate 10 prints.
4	Scratch on the heat roller	Are the horizontal lines at 78 mm (heat roller circumference) intervals?	Yes	Replace the fuser unit.
5	HVPS control PCB failure	Is the problem solved after replacing the HVPS control PCB ASSY?	Yes	Replace the HVPS control PCB ASSY.
6	High-voltage power supply PCB failure	Is the problem solved after replacing the high-voltage power supply PCB ASSY.	Yes	Replace the high-voltage power supply PCB ASSY.



■ Ghost

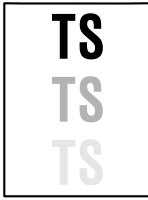

<User Check>

- Check the machine's environment, conditions such as high humidity may cause this situation to occur.
- Check that the appropriate media type is selected in the printer driver.
- Replace the drum unit with a new one.

Step	Cause	Check	Result	Remedy
1	HVPS control PCB failure	Is the problem solved after replacing the HVPS control PCB ASSY?	Yes	Replace the HVPS control PCB ASSY.
2	High-voltage power supply PCB failure	Is the problem solved after replacing the high-voltage power supply PCB ASSY?	Yes	Replace the high-voltage power supply PCB ASSY.
3	Engine PCB failure	Is the problem solved after replacing the engine PCB ASSY?	Yes	Replace the engine PCB ASSY.

■ Color misregistration



<User Check>

- Implement the adjustment of color registration from the control panel cover ASSY.
- Replace the belt unit with a new one.
- Replace the drum unit with a new one.

Step	Cause	Check	Result	Remedy
1	Engine PCB failure	Is the problem solved after replacing the engine PCB ASSY?	Yes	Replace the engine PCB ASSY.
2	Registration mark L PCB ASSY failure	Is the problem solved after replacing the registration sensor holder ASSY?	Yes	Replace the registration sensor holder ASSY.

■ Fogging

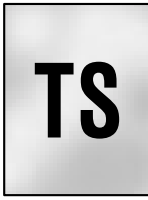

<User Check>

- Replace the toner cartridge with a new one.
- Replace the drum unit with a new one.
- Do not use acid paper.

Step	Cause	Check	Result	Remedy
1	Toner/new sensor PCB failure	Is the toner sensor performed normally by following the procedure described in "Function code 32" to check?	No	Replace the toner/new sensor PCB ASSY.
2	HVPS control PCB failure	Is the problem solved after replacing the HVPS control PCB ASSY?	Yes	Replace the HVPS control PCB ASSY.
3	High-voltage power supply PCB failure	Is the problem solved after replacing the high-voltage power supply PCB ASSY?	Yes	Replace the high-voltage power supply PCB ASSY.
4	Engine PCB failure	Is the problem solved after replacing the engine PCB ASSY?	Yes	Replace the engine PCB ASSY.

**Note:**

This problem often occurs when the drum unit or toner cartridge is nearly at the end of life.

■ Unstable color density

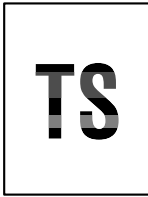

<User Check>

- Make a print on a different type of paper.
- Replace the belt unit with a new one.
- Replace the drum unit with a new one.
- Replace the waste toner box with a new one.
- Replace the toner cartridge with a new one.

Step	Cause	Check	Result	Remedy
1	Drum unit conduction failure	Are the electrodes on the drum unit and machine body dirty?	Yes	Clean both electrodes. (Refer to Fig. 3-3 (P3-32) and Fig. 3-6 (P3-33))
2	Toner cartridge connection failure	Are the electrodes on the toner cartridge and machine body dirty?	Yes	Clean both electrodes. (Refer to Fig. 3-3 (P3-32) and Fig. 3-6 (P3-33))
3	Dirt on belt unit electrode	Are the electrodes on the belt unit and machine body dirty?	Yes	Clean both electrodes. (Refer to Fig. 3-4 (P3-32) and Fig. 3-6 (P3-33))
4	Engine PCB failure	Is the problem solved after replacing the engine PCB ASSY?	Yes	Replace the engine PCB ASSY.
5	HVPS control PCB failure	Is the problem solved after replacing the HVPS control PCB ASSY?	Yes	Replace the HVPS control PCB ASSY.
6	High-voltage power supply PCB failure	Is the problem solved after replacing the high-voltage power supply PCB ASSY?	Yes	Replace the high-voltage power supply PCB ASSY.
7	LED head control PCB failure	Is the problem solved after replacing the LED head control PCB ASSY?	Yes	Replace the LED head control PCB ASSY.
8	Main PCB failure	Is the problem solved after replacing the main PCB ASSY?	Yes	Replace the main PCB ASSY.

■ Hollow print

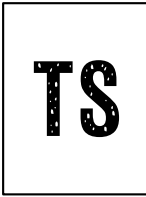

**<User Check>**

- Select "Improve Toner Fixing" in the printer driver, or select "Thicker Paper" in Paper Type.
- Check the machine's environment, conditions such as high humidity and low humidity may cause this situation to occur.
- Make a print on a different type of paper.
- Replace the drum unit with a new one.
- Replace the toner cartridge with a new one.

Step	Cause	Check	Result	Remedy
1	Fuser unit failure	Is the problem solved after replacing the fuser unit?	Yes	Replace the fuser unit.

## 5. SOFTWARE SETTING PROBLEMS

The end user can solve problems pertaining to software, for instance, print cannot be made from a computer although test print and printer setting print can be made from the machine, by following the User Check items. If the same problem occurs, follow each procedure in the order of the number described in the Step column in the tables below.

### 5.1 Cannot Print Data

#### <User Check>

- Check that the USB cable or LAN cable is not damaged.
- Check that the correct machine is selected if you have an interface switching device.
- Check the descriptions on the software setting in the user's guide.
- Restore the settings at factory shipment. (Refer to User's guide)

Step	Cause	Check	Result	Remedy
1	Failure inside the machine	Does the machine print "Printer Settings"?	No	Identify the error type, and then refer to the specified section of this chapter.
2	Machine connection	For Macintosh, has the product ID been verified?	No	Verify the product ID. (Hexadecimal) Product ID: HL-3040CN: 0037 HL-3070CW: 0038
3	USB direct interface relay PCB failure (HL-3070CW only)	Is the problem solved after replacing the USB direct interface relay PCB ASSY?	Yes	Replace the USB direct interface relay PCB ASSY.
4	Main PCB failure	Is the problem solved after replacing the main PCB ASSY?	Yes	Replace the main PCB ASSY.

## 6. NETWORK PROBLEMS

---

### 6.1 Cannot Make a Print through Network Connection

<User Check>

- Check the descriptions in the network user's guide.
- Restore the settings at factory shipment. (Refer to User's guide)

Step	Cause	Check	Result	Remedy
1	Mismatch of MAC address (Ethernet Address) between wireless LAN PCB and main PCB (HL-3070CW only)	Is the problem solved after obtaining the correct MAC address (Ethernet Address)?	Yes	Obtain the MAC address (Ethernet Address). (Refer to "2.1 Acquiring MAC Address (Ethernet Address) from Main PCB" in Chapter 6.)
2	Wireless LAN PCB failure (HL-3070CW only)	Is the problem solved after replacing the wireless LAN PCB ASSY?	Yes	Replace the wireless LAN PCB ASSY.
3	Main PCB failure	Is the problem solved after replacing the main PCB ASSY?	Yes	Replace the main PCB ASSY.

## 7. OTHERS PROBLEMS

### 7.1 The Machine is Not Turned ON, or The LCD Indication Does Not Appear.

Step	Cause	Check	Result	Remedy
1	Harness connection failure of panel PCB ASSY	Is the harness of the panel PCB ASSY connected correctly?	No	Reconnect the panel PCB ASSY harness.
2	Harness connection failure of LCD	Is the harness of the LCD connected correctly?	No	Reconnect the LCD harness.
3	LCD failure	Is the problem solved after replacing the LCD?	Yes	Replace the LCD.
4	Low-voltage power supply PCB failure	Is the problem solved after replacing the low-voltage power supply PCB ASSY?	Yes	Replace the low-voltage power supply PCB ASSY.
5	Panel PCB failure	Is the problem solved after replacing the panel PCB ASSY?	Yes	Replace the panel PCB ASSY.
6	HVPS control PCB failure	Is the problem solved after replacing the HVPS control PCB ASSY?	Yes	Replace the HVPS control PCB ASSY.
7	High-voltage power supply PCB failure	Is the problem solved after replacing the high-voltage power supply PCB ASSY?	Yes	Replace the high-voltage power supply PCB ASSY.
8	Main PCB failure	Is the problem solved after replacing the main PCB ASSY?	Yes	Replace the main PCB ASSY.

**Note:**

When the error code 36 occurs, the power is forcibly turned OFF, and the machine cannot be turned ON for 10 minutes.

## 7.2 The Fan Does Not Work.

Step	Cause	Check	Result	Remedy
1	Harness connection failure of the appropriate fan	Is the harness of the appropriate fan connected correctly?	No	Reconnect the harness of the appropriate fan correctly.
2	Failure of the appropriate fan	Is the problem solved after replacing the appropriate fan?	Yes	Replace the appropriate fan.
3	Engine PCB failure	Is the problem solved after replacing the engine PCB ASSY?	Yes	Replace the engine PCB ASSY.
4	HVPS control PCB failure	Is the problem solved after replacing the HVPS control PCB ASSY?	Yes	Replace the HVPS control PCB ASSY.
5	High-voltage power supply PCB failure	Is the problem solved after replacing the high-voltage power supply PCB ASSY?	Yes	Replace the high-voltage power supply PCB ASSY. Replace the appropriate fan.
6	Low-voltage power supply PCB failure	Is the problem solved after replacing the low-voltage power supply PCB ASSY?	Yes	Replace the low-voltage power supply PCB ASSY.
7	Main PCB failure	Is the problem solved after replacing the main PCB ASSY?	Yes	Replace the main PCB ASSY.



# **CHAPTER 4**

## **PERIODICAL MAINTENANCE**

# CHAPTER 4

## PERIODICAL MAINTENANCE

This chapter details consumable parts and periodical maintenance parts. This chapter also covers procedures for disassembling and assembling periodical maintenance parts.

### CONTENTS

- 1. SAFETY PRECAUTIONS .....4-1**
- 2. CONSUMABLE PARTS .....4-1**
- 3. PERIODICAL MAINTENANCE PARTS .....4-2**
  - 3.1 Periodical Maintenance Parts ..... 4-2
  - 3.2 Procedures to Replace Periodical Maintenance Parts ..... 4-3
    - 3.2.1 Fuser unit..... 4-4
    - 3.2.2 Paper feeding kit..... 4-16

# 1. SAFETY PRECAUTIONS

To avoid creating secondary problems by mishandling, follow the warnings below during maintenance work.

**⚠ WARNING**

- Always turn off the power switch and unplug the power cord from the power outlet before accessing any parts inside the machine.
- When opening the top cover or back cover to access any parts inside the machine, never touch the shaded parts shown in the following figures.

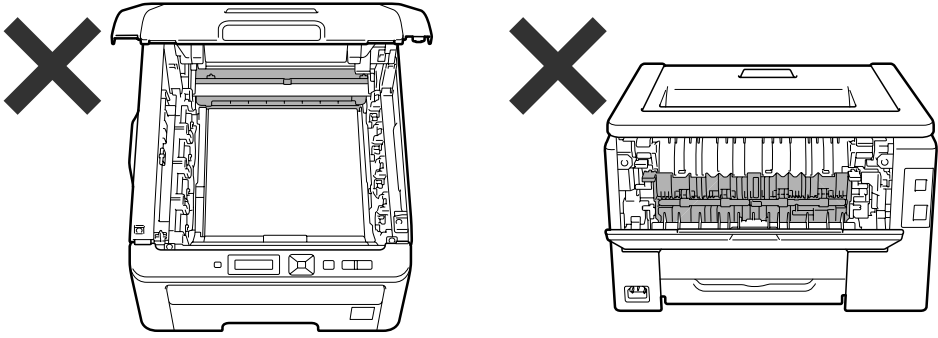

# 2. CONSUMABLE PARTS

Parts name			Approximate life
Toner cartridge	Black	Starter cartridge	Approximately 1,000 pages (When printing A4-size paper in accordance with ISO/IEC 19798)
		Standard cartridge	Approximately 2,200 pages (When printing A4-size paper in accordance with ISO/IEC 19798)
	Cyan, Magenta, Yellow	Starter cartridge	Approximately 1,000 pages (When printing A4-size paper in accordance with ISO/IEC 19798)
		Standard cartridge	Approximately 1,400 pages (When printing A4-size paper in accordance with ISO/IEC 19798)
Drum unit			Approximately 15,000 pages (When printing one A4-size paper at a time) The life expectancy varies according to the use condition.
Belt unit			Approximately 50,000 pages (When printing A4-size paper) The life expectancy varies according to the use condition.
Waste toner box			Approximately 50,000 pages

## 3. PERIODICAL MAINTENANCE PARTS

### 3.1 Periodical Maintenance Parts

Periodical maintenance parts are the parts to be replaced periodically to maintain product quality. These parts would affect the product quality if they lose their functionality even if they do not appear to be damaged or there is no change in their appearance.

The periodical maintenance parts listed in the table below should be replaced according to the service life.

Parts name	LCD	Q'ty	Approximate life	Replacement procedure
Fuser unit	Replace Fuser	1	50,000 pages	Refer to <a href="#">3.2.1</a>
Paper feeding kit*	Replace PF Kit1	1	50,000 pages	Refer to <a href="#">3.2.2</a>

\* The paper feeding kit includes the separation pad ASSY, pad spring and roller holder ASSY.

When replacing the periodical maintenance parts, each of the counters need to be reset in order to record the number of replacement times. (Refer to [“2.3 Parts Life Reset Function”](#) in [Chapter 7](#).)

The number of printed pages of the machine can be checked on Print Settings. (Refer to [“2.4 Printout of Printer Settings”](#) in [Chapter 7](#).)

The actual number of printed page will vary depending on the type of print job or the paper to be used. The figures indicated as the approximate life in the table above are worked out when printing a general business document (in accordance with ISO/IEC 19798) on A4-size paper.

**Note:**

- Always turn off the power switch of the machine and unplug the power cord from the power outlet before replacing the periodical maintenance parts.
- If the fuser unit is replaced after an error related to the fuser unit occurs, you need to wait until the machine sufficiently cools down before replacing the unit. After replacing the unit, turn ON the machine and leave it for approximately fifteen minutes. This will make the machine to be released from the error.

## 3.2 Procedures to Replace Periodical Maintenance Parts

### ■ Preparation

Prior to proceeding with the disassembly procedure,

- (1) Unplug
  - the AC cord,
  - the USB cable, if connected,
  - the LAN cable, if connected, and
  - the USB cable for PictBridge or USB flash memory drive, if connected.
- (2) Remove the Paper tray.

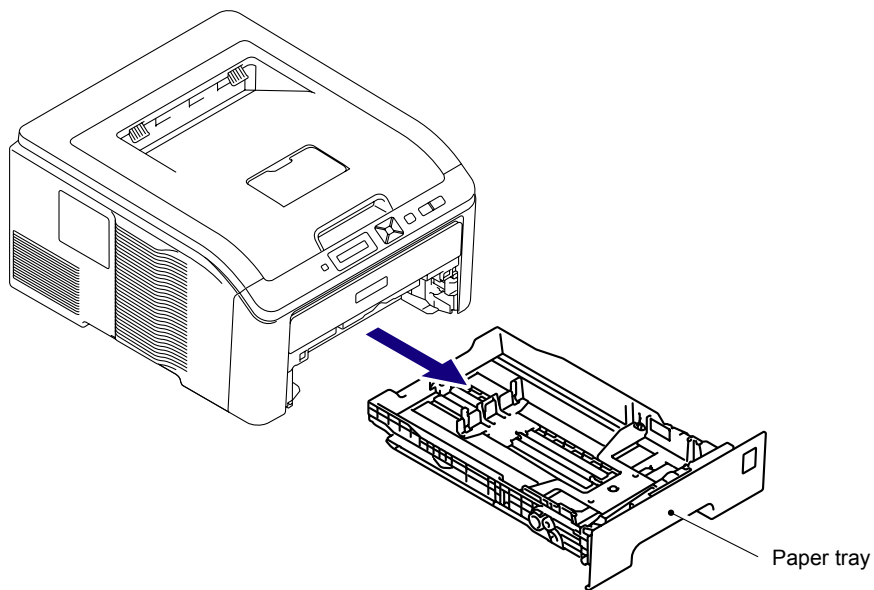

**3.2.1 Fuser unit**

**<Uninstalling procedure>**

(1) Open the Back cover.

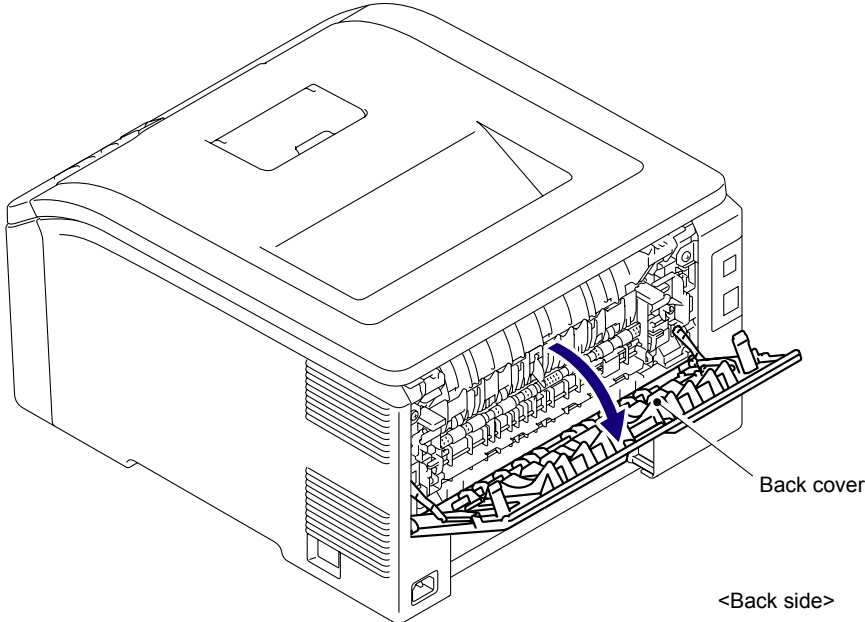

**Fig. 4-1**

(2) Release the Hook and remove the Back cover stopper L and R from the Main body.

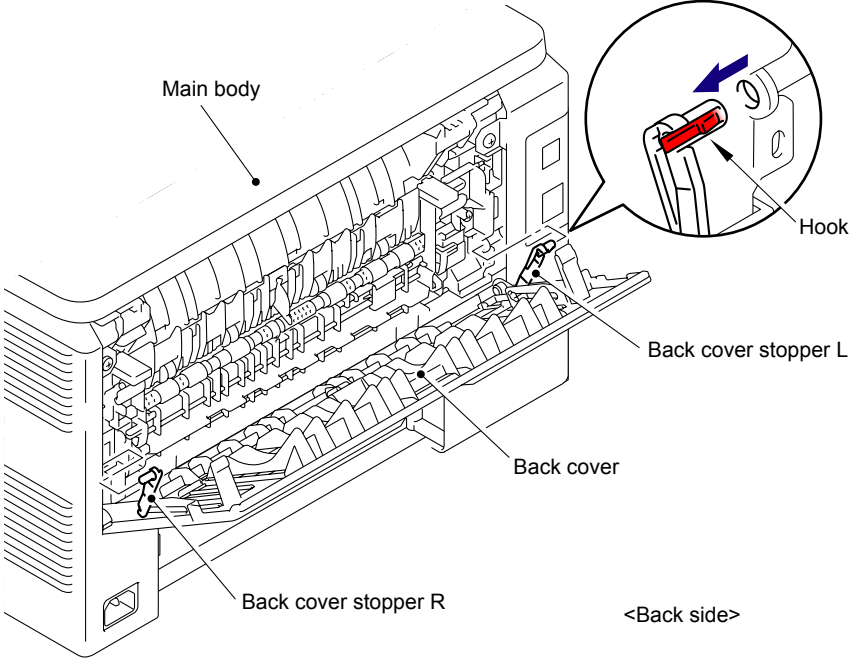

**Fig. 4-2**

(3) Remove the Bush of the Back cover from the Shaft at the right side of the Main body.

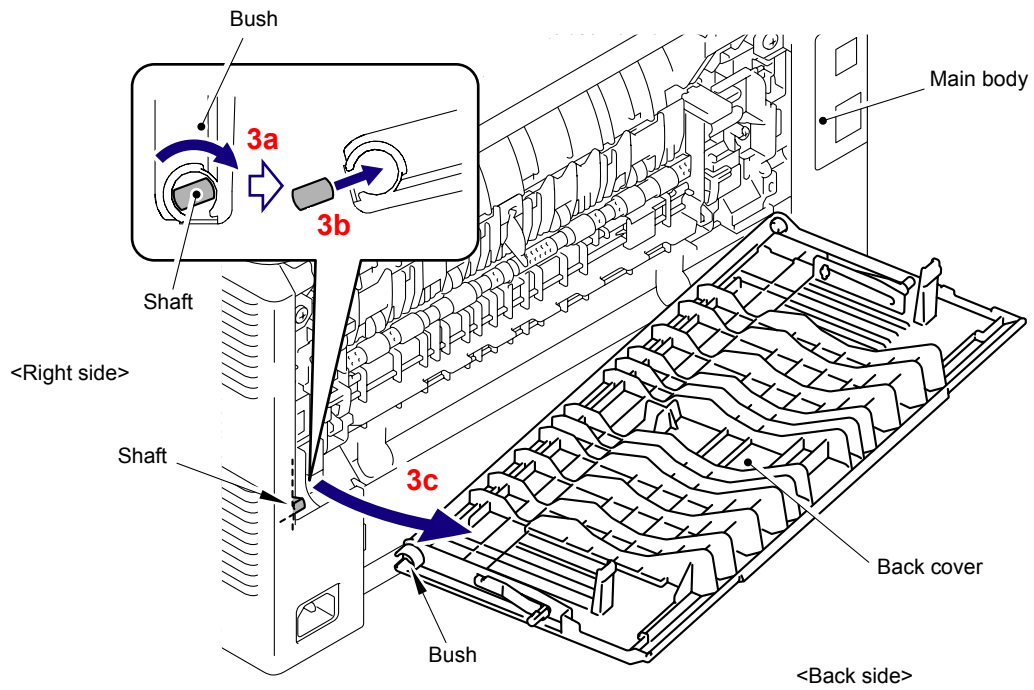

Fig. 4-3

(4) Remove the Back cover from the Shaft at the left side of the Main body.

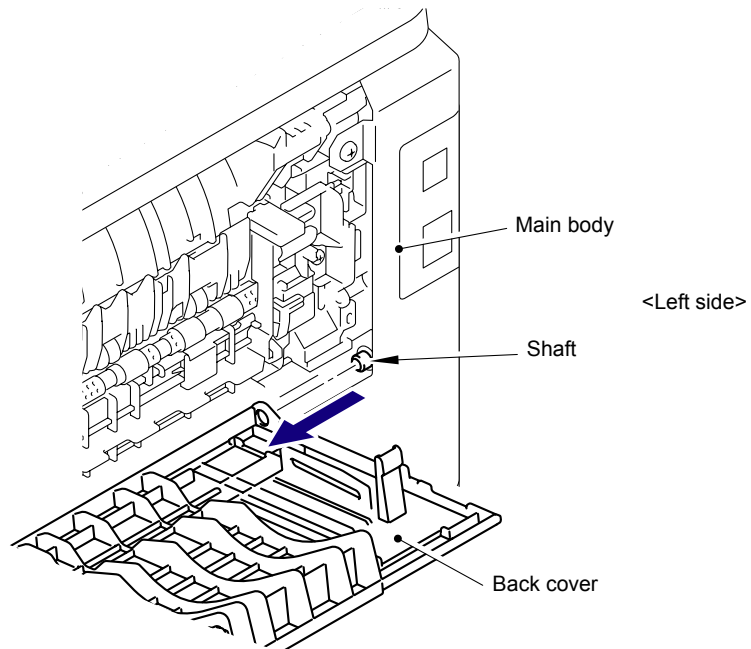

Fig. 4-4

- (5) Release the Fuser cover lock lever L and R, and open the Fuser cover.

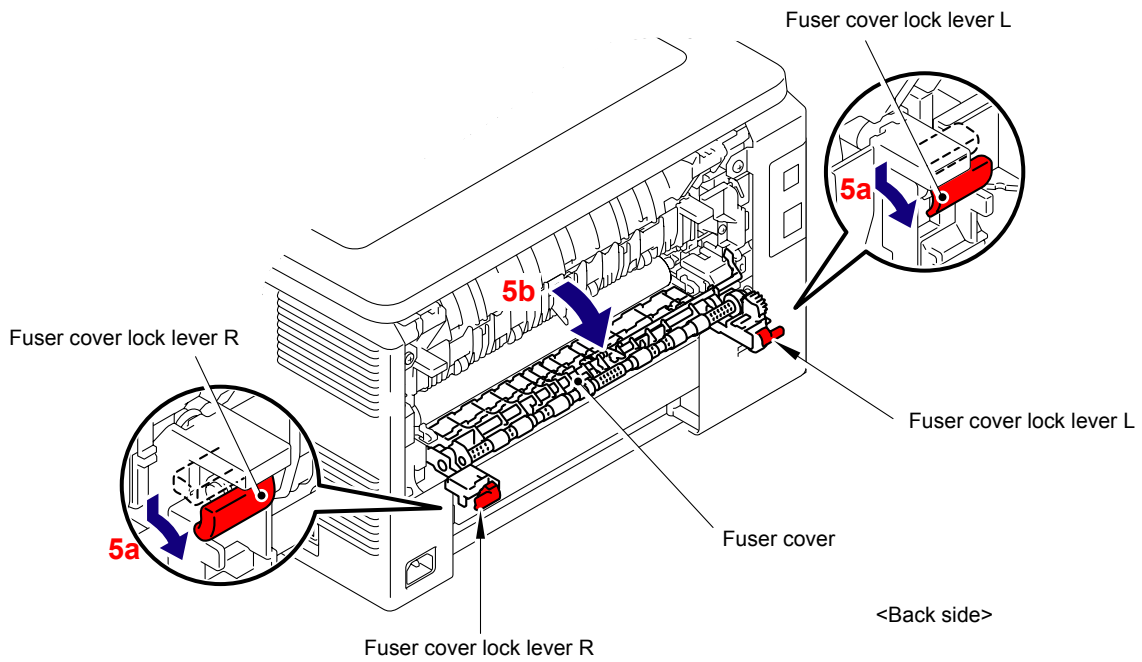

Fig. 4-5

- (6) Take out the Shaft at the left side of the Fuser cover from the Notch on the Bush of the Side frame L.
- (7) Take out the Shaft at the right side of the Fuser cover from the Bush of the LVPS cover, and remove the Fuser cover.

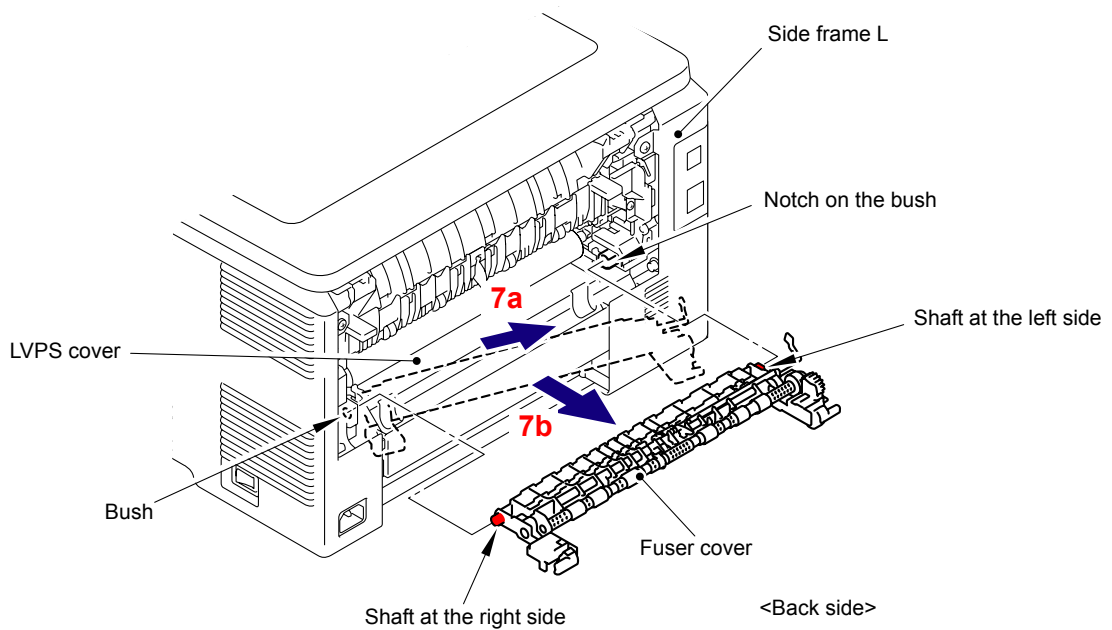
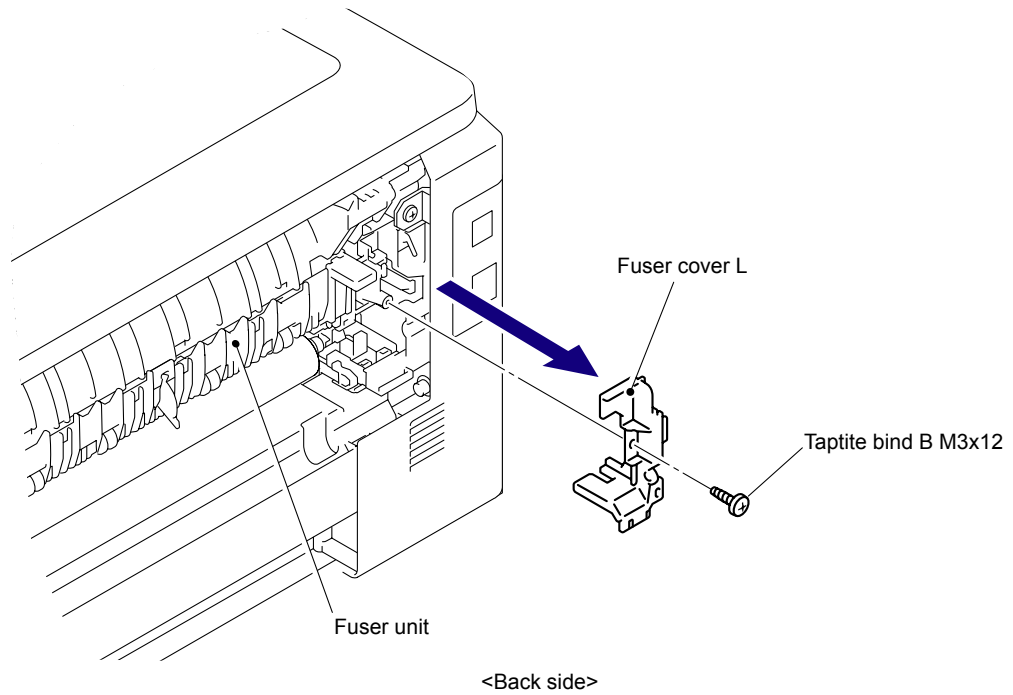

Fig. 4-6



- (8) Remove the Taptite bind B M3x12 screw, and then remove the Fuser cover L from the Fuser unit.



**Fig. 4-7**

- (9) Remove the Taptite bind B M3x12 screw, and then remove the Fuser cover R from the Fuser unit.

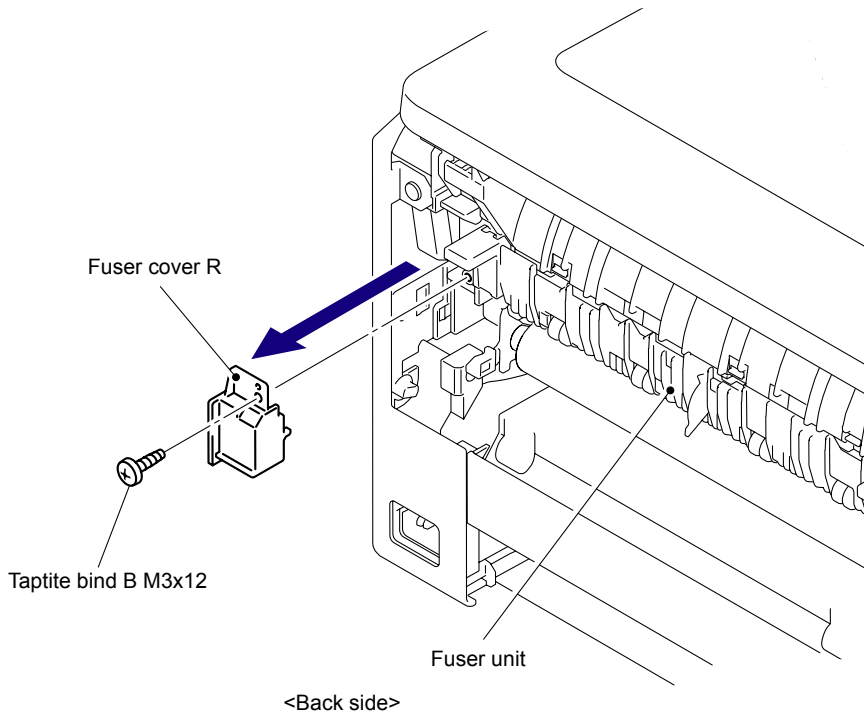

**Fig. 4-8**

(10) Disconnect the two Connectors (CN1, CN3) from the Eject front sensor PCB ASSY.

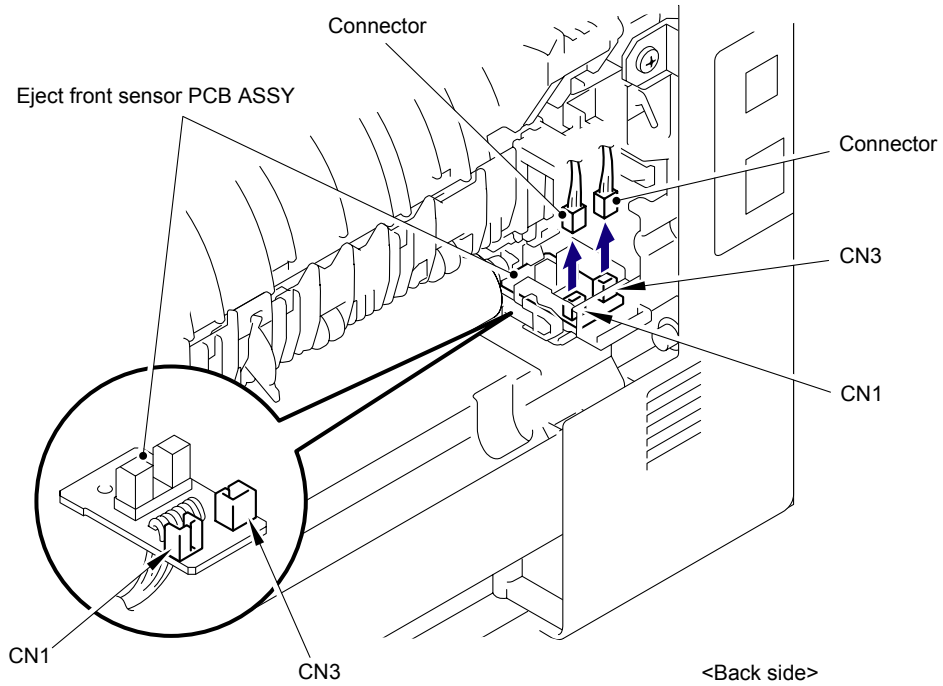

**Fig. 4-9**

(11) Disconnect the two Electrode terminals from the Fuser unit.

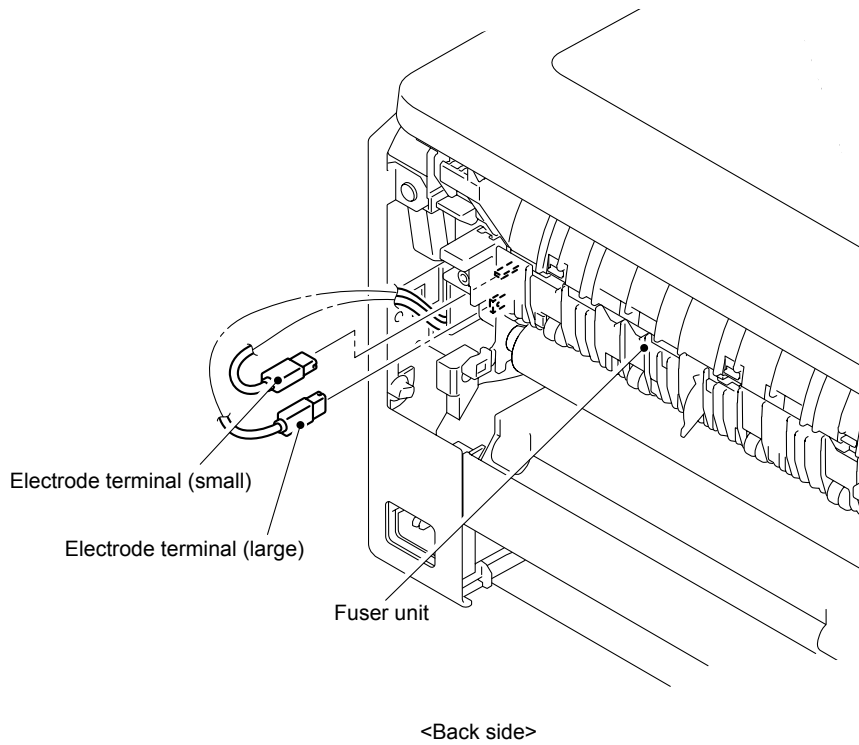

**Fig. 4-10**

(12) Remove the two Taptite pan B M4x14 screws, and then remove the Fuser unit from the Main body while holding the "A."

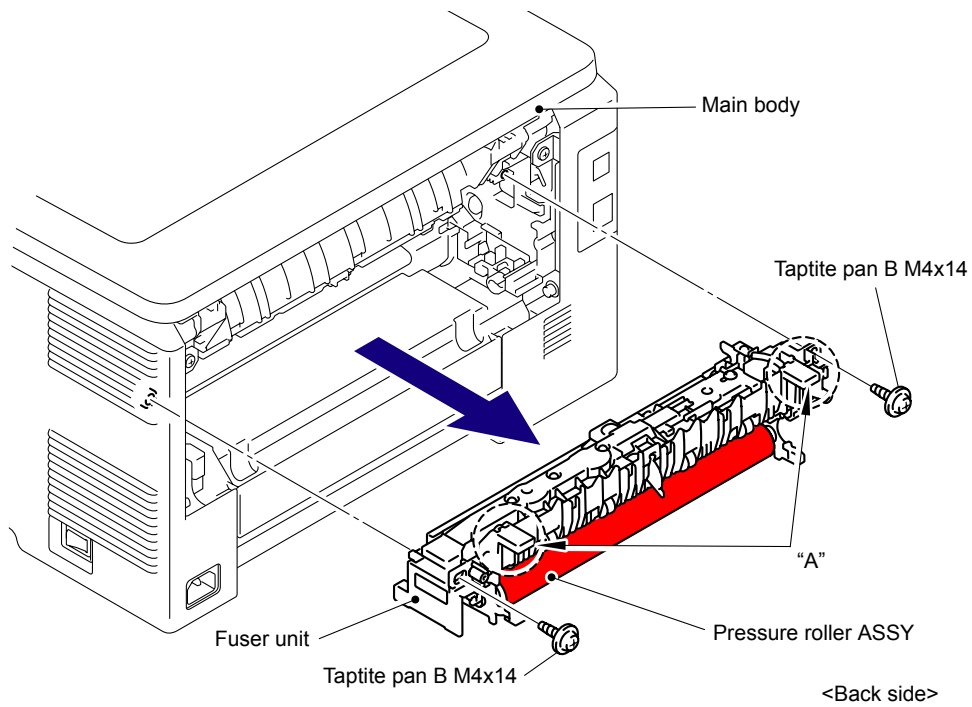

Fig. 4-11

**Note:**

- Do not apply a physical impact or vibration to the Fuser unit.
- Do not touch the roller and electrodes as shown in the figure below to prevent breakage of the Fuser unit.

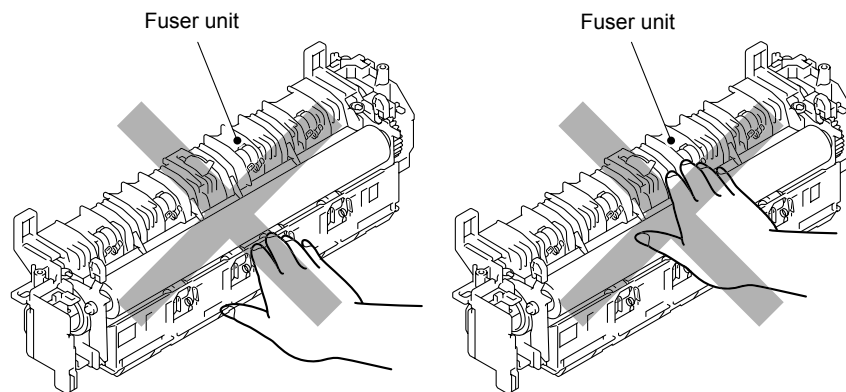
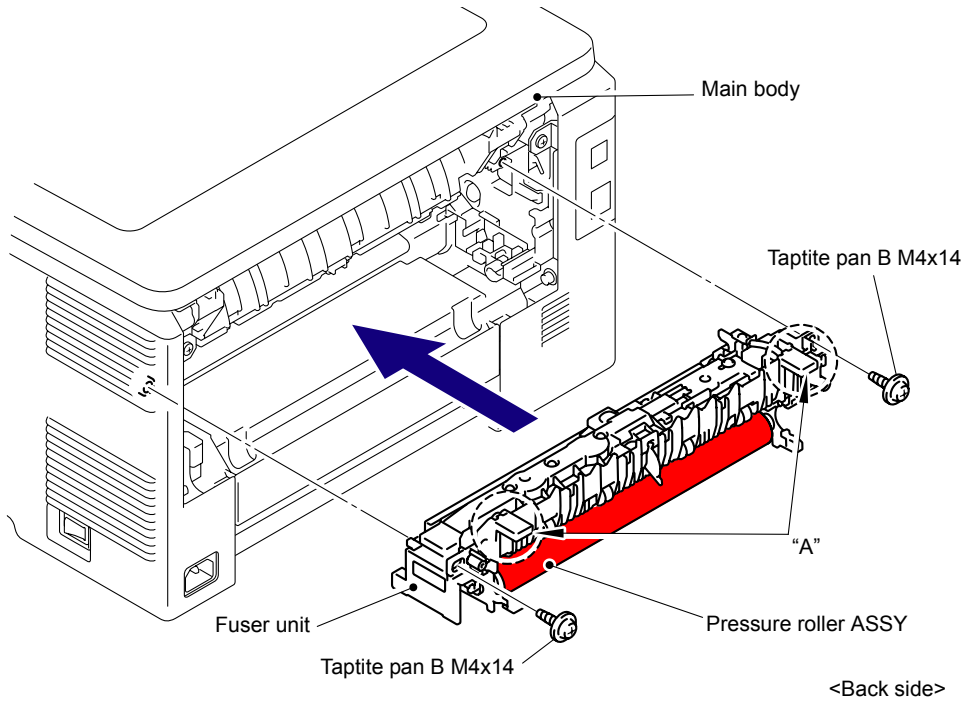

Fig. 4-12

**<Installing procedure>**

- (1) Assemble the Fuser unit while holding the "A", and then secure it with the two Taptite pan B M4x14 screws.



**Fig. 4-13**

**Note:**

The Fuser unit for replacement is transported while the pressure roller is held lightly to prevent deformation of the pressure roller. When assembling the Fuser unit, make sure to assemble the Fuser unit to the product first, and then remove the Spacer in the direction of the arrow from the Fuser unit.

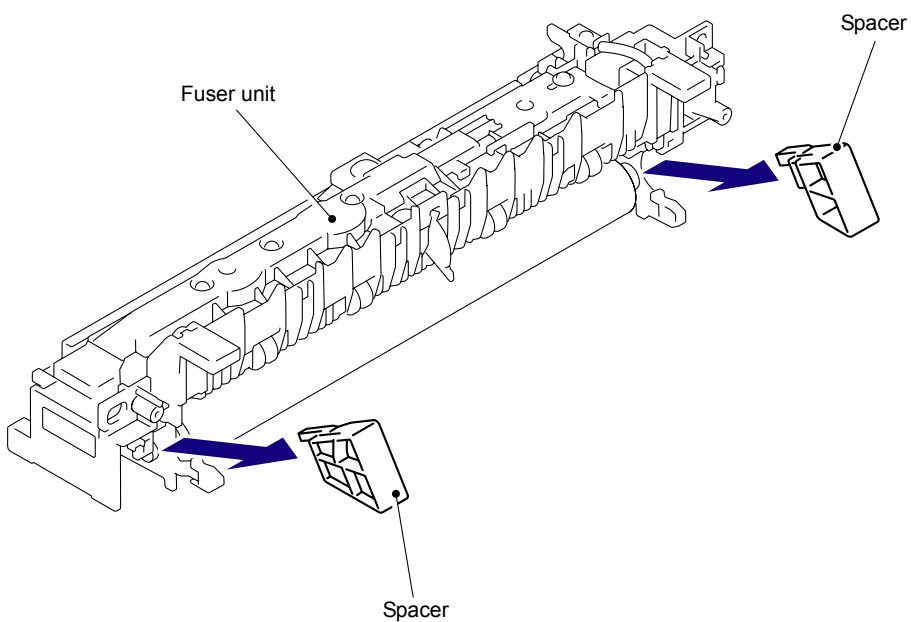

**Fig. 4-14**

(2) Connect the two Electrode terminals into the Fuser unit.

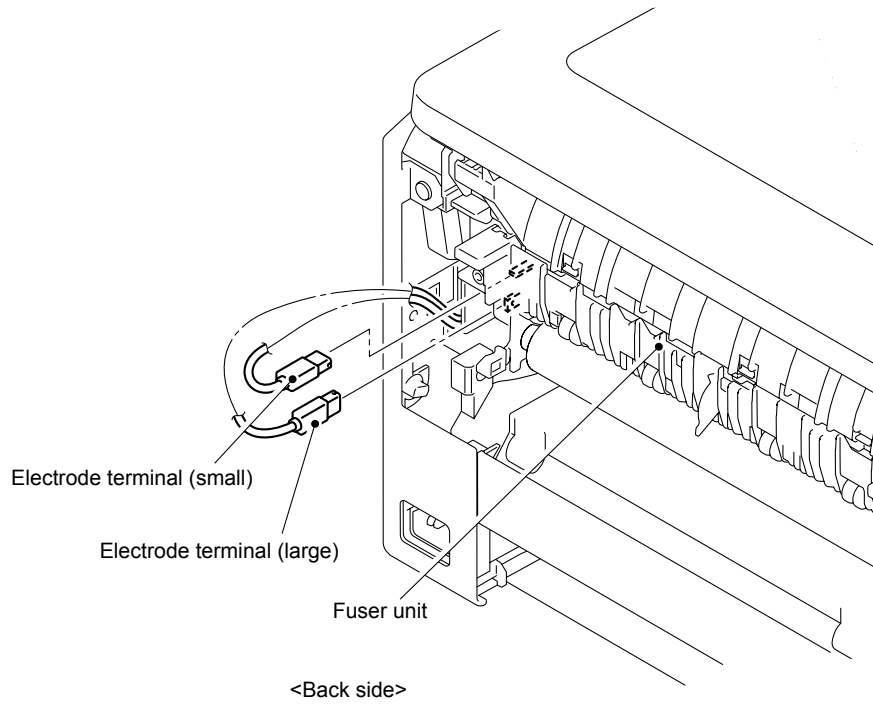

**Fig. 4-15**

(3) Connect the two connectors (CN1, CN3) into the Eject front sensor PCB ASSY.

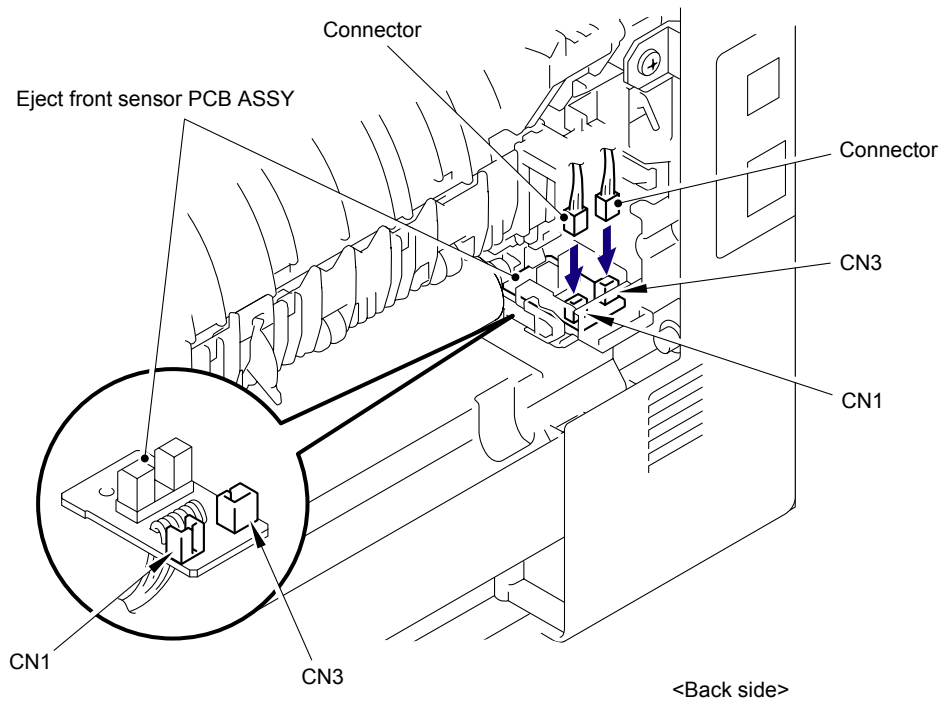
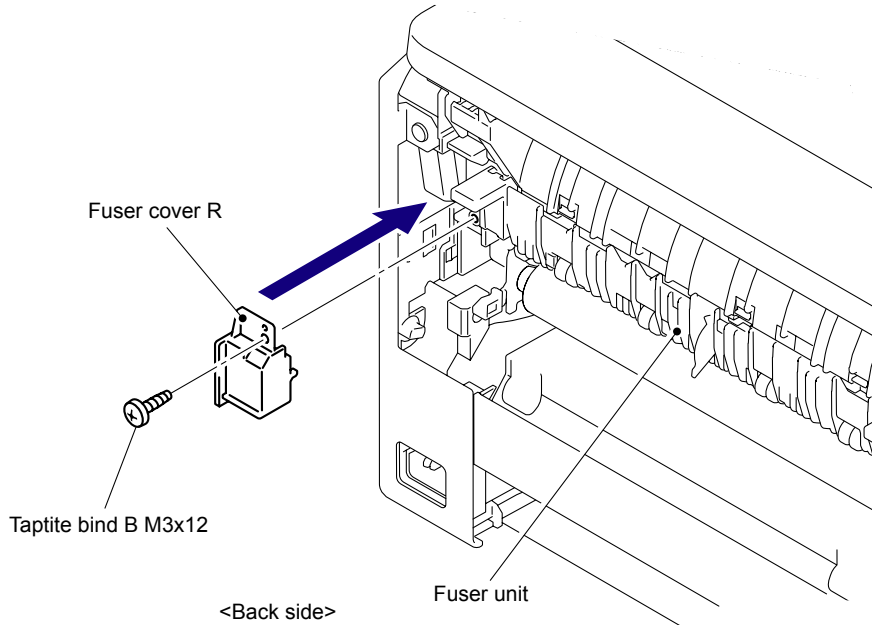

**Fig. 4-16**

- (4) Assemble the Fuser cover R to the Fuser unit with the Taptite bind B M3x12 screw.

**Note:**

Do not pinch the harness from the low-voltage power supply PCB ASSY to the Fuser unit.

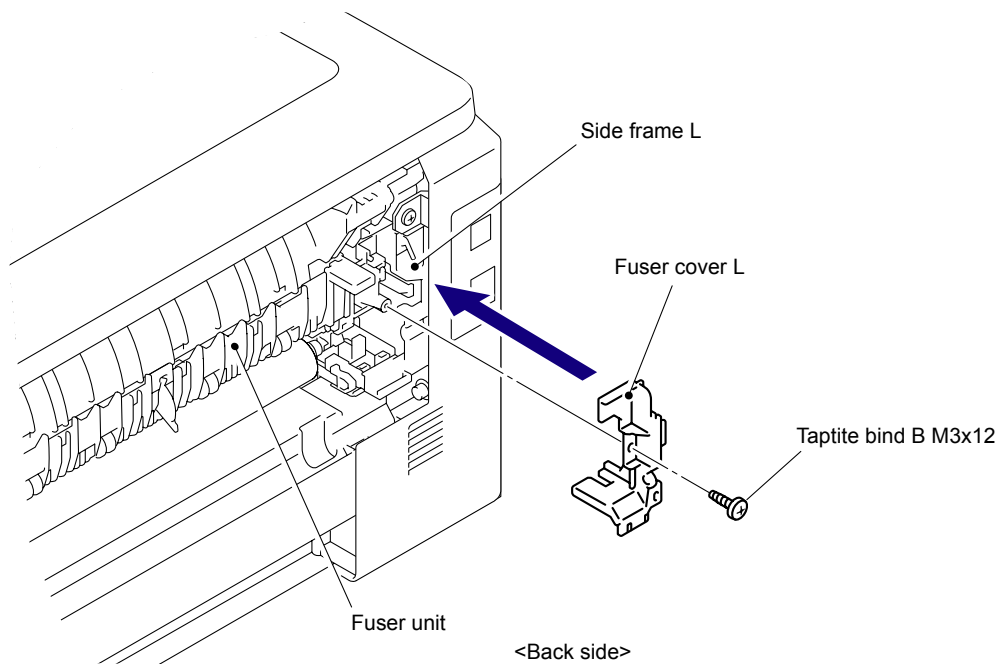

**Fig. 4-17**

- (5) Assemble the Fuser cover L to the Fuser unit with the Taptite bind B M3x12 screw.

**Note:**

Mount the Fuser cover L as holding down the harness of the thermistor to the Side frame L side. (If the harness is protruded, it hooks up the eject front actuator.)



**Fig. 4-18**

- (6) Assemble the Shaft at the right side of the Fuser cover to the Bush of the LVPS cover.
- (7) Assemble the Shaft at the left side of the Fuser cover to the Notch on the bush of the Side frame L.

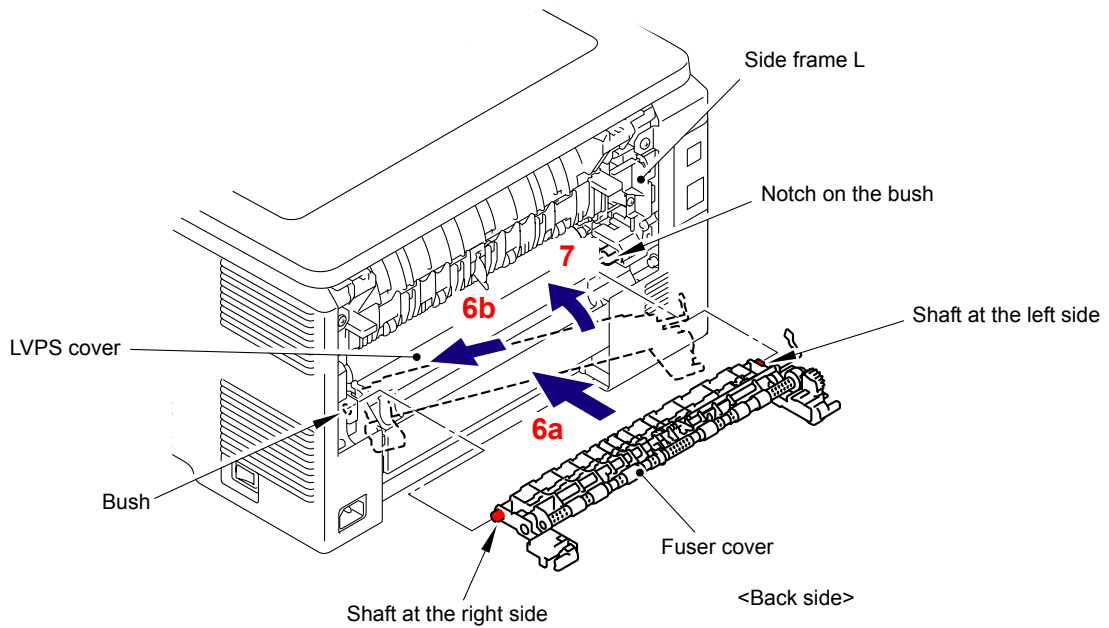

Fig. 4-19

- (8) Close the Fuser cover.

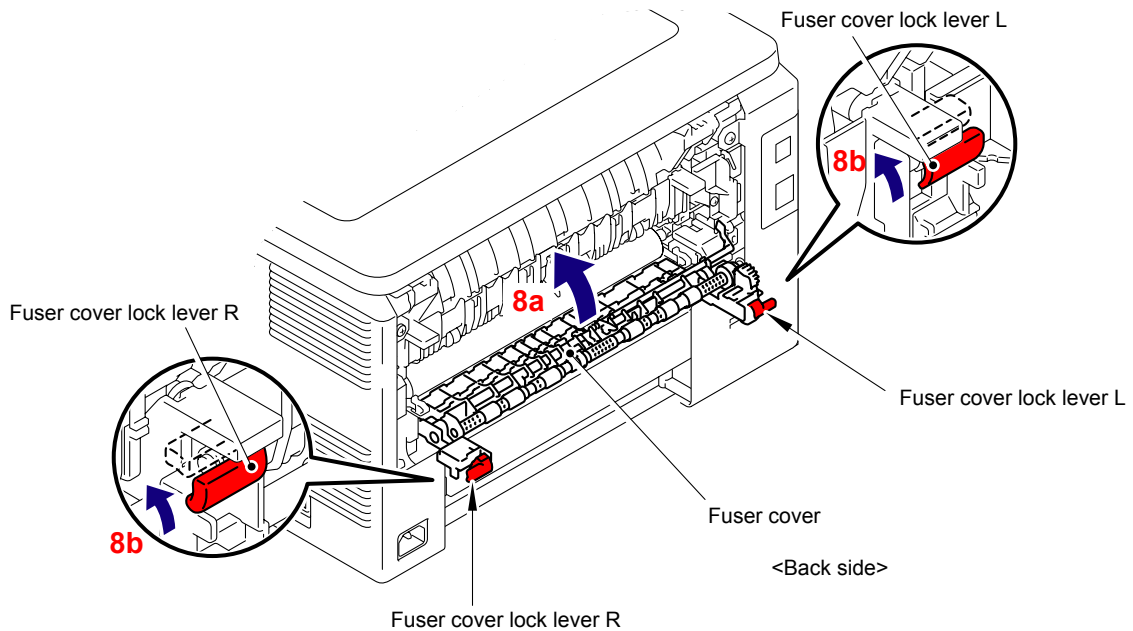

Fig. 4-20

(9) Assemble the Back cover to the Shaft at the left side of the Main body.

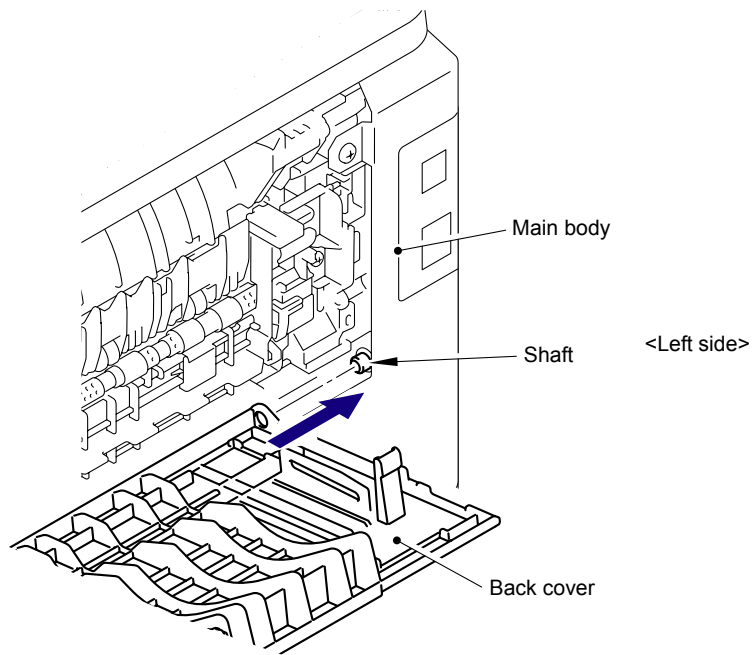

Fig. 4-21

(10) Assemble the Bush of the Back cover to the Shaft at the right side of the Main body.

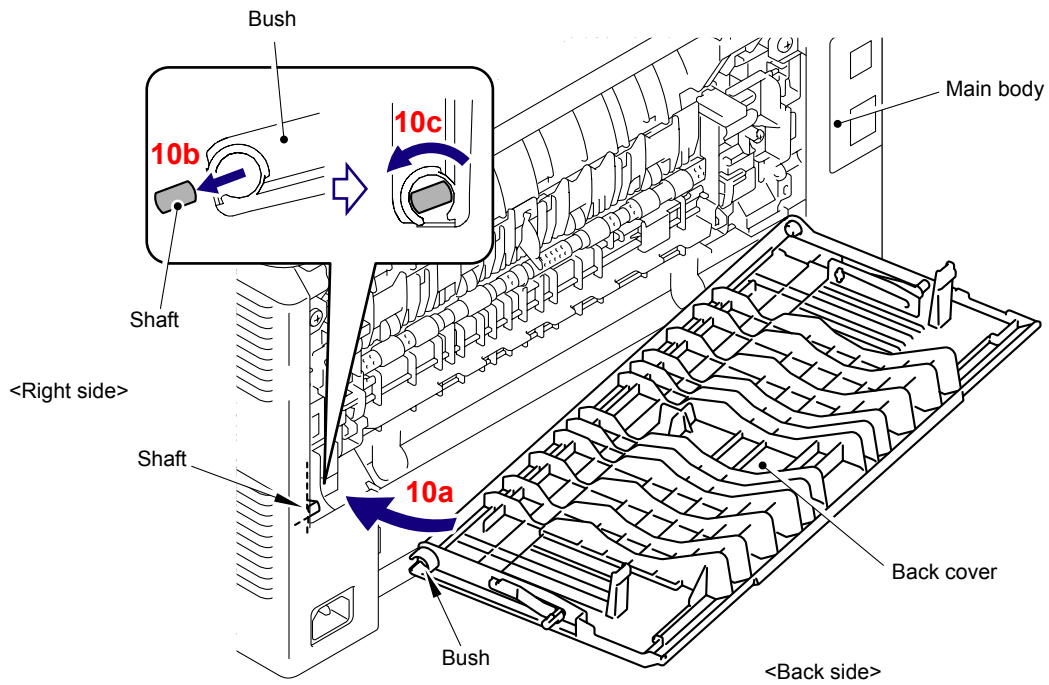

Fig. 4-22



(11) Assemble the back cover stopper L and back cover stopper R to the main body.

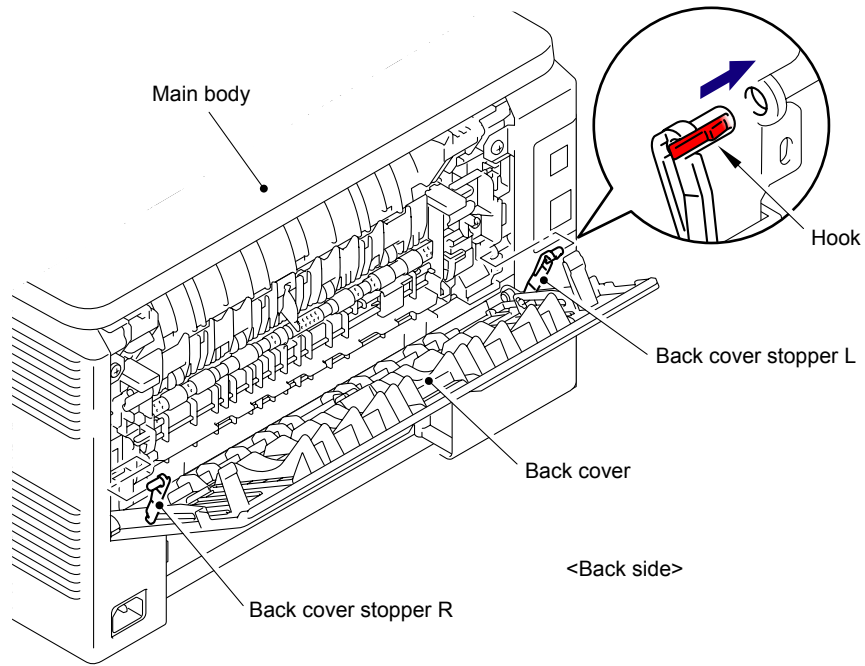

Fig. 4-23

(12) Close the Back cover.

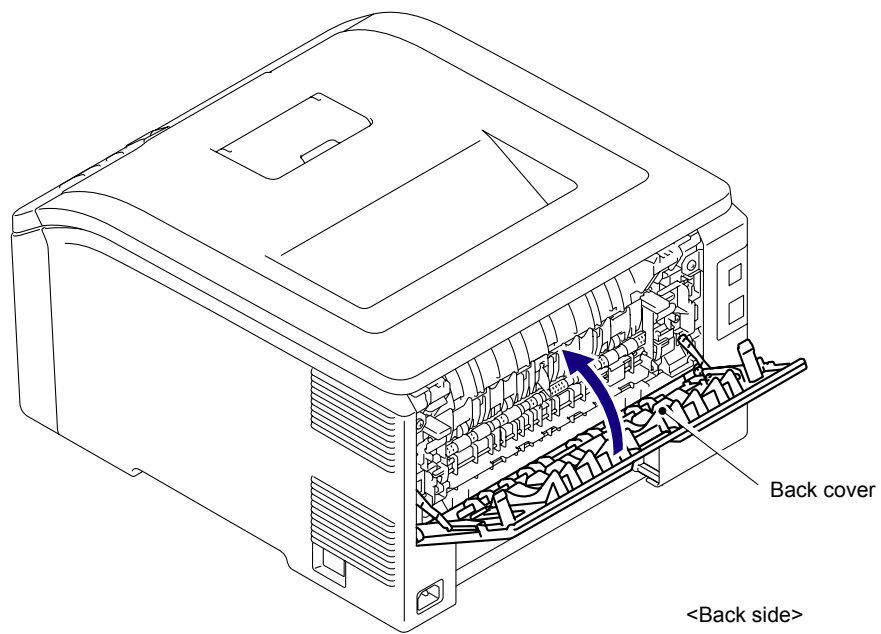

Fig. 4-24

(13) After replacing the Fuser unit, reset the counter. (Refer to "2.3 Parts Life Reset Function" in Chapter7.)

### 3.2.2 Paper feeding kit

#### <Uninstalling procedure>

- (1) Release the two Hooks of the Separation pad ASSY from the Paper tray.
- (2) Release the two Pins to remove the Separation pad ASSY from Paper tray.

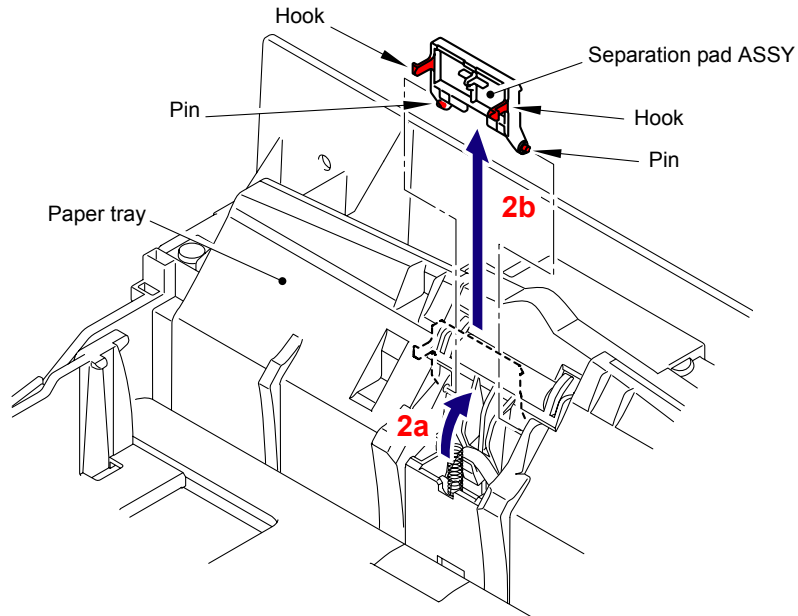

Fig. 4-25

- (3) Remove the Pad spring from the Paper tray.

#### **Note:**

Be careful not to loose the Pad spring.

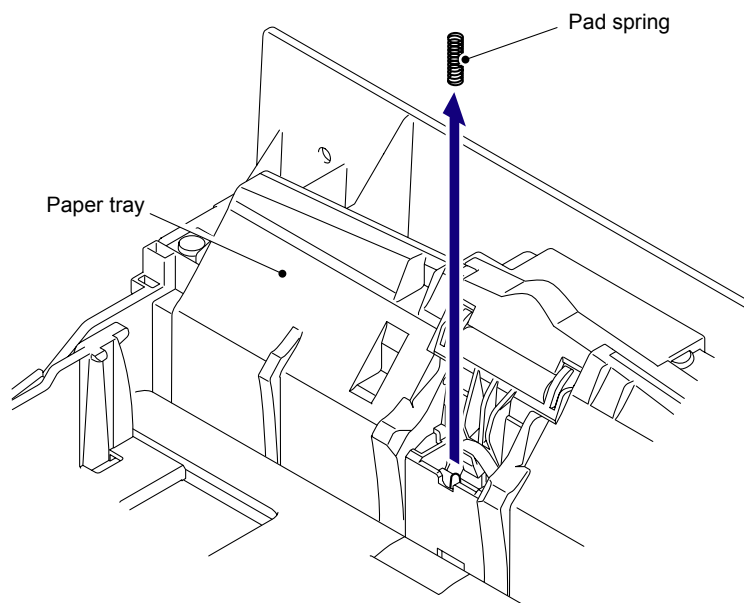

Fig. 4-26

- (4) Push the Lift arm to the back and remove "B" of the Roller holder ASSY from "A" of the Lift arm, and the Roller holder ASSY rotates in the direction of the arrow 4b.

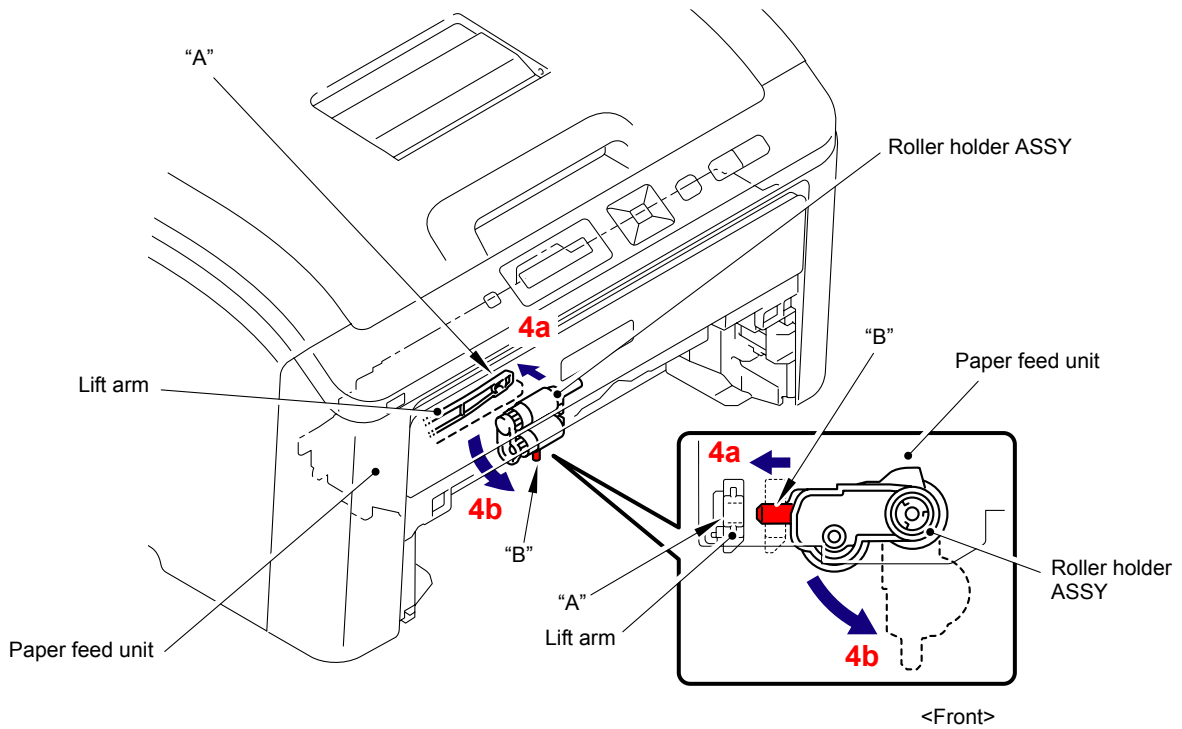

Fig. 4-27

- (5) Slide the Roller holder ASSY in the direction of the arrow 5 and remove it from the "C" of the Paper feed unit.
- (6) Slide the Roller holder ASSY in the direction of the arrow 6a and 6b in this order and remove it.

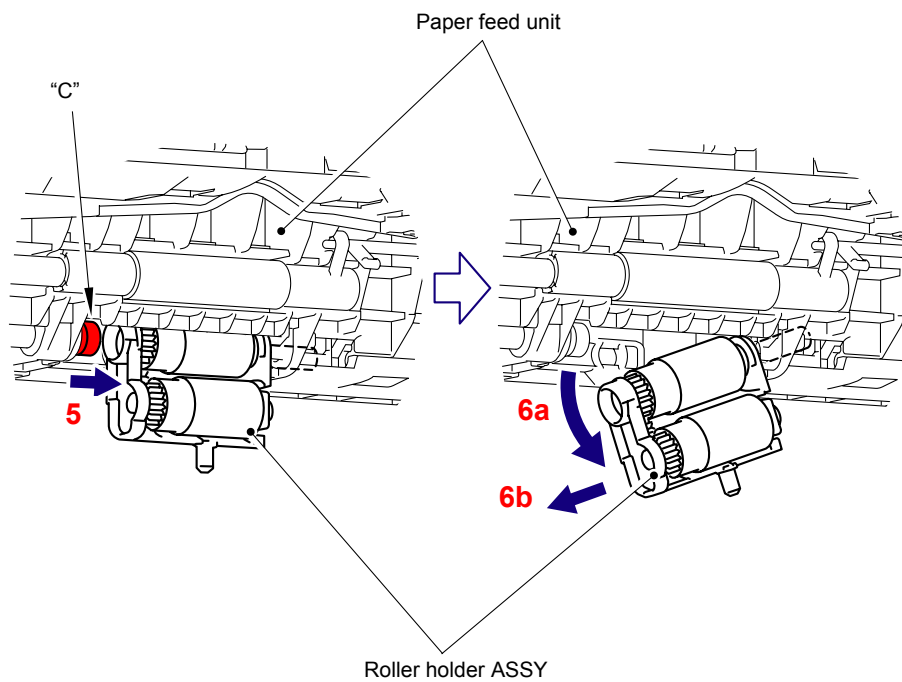
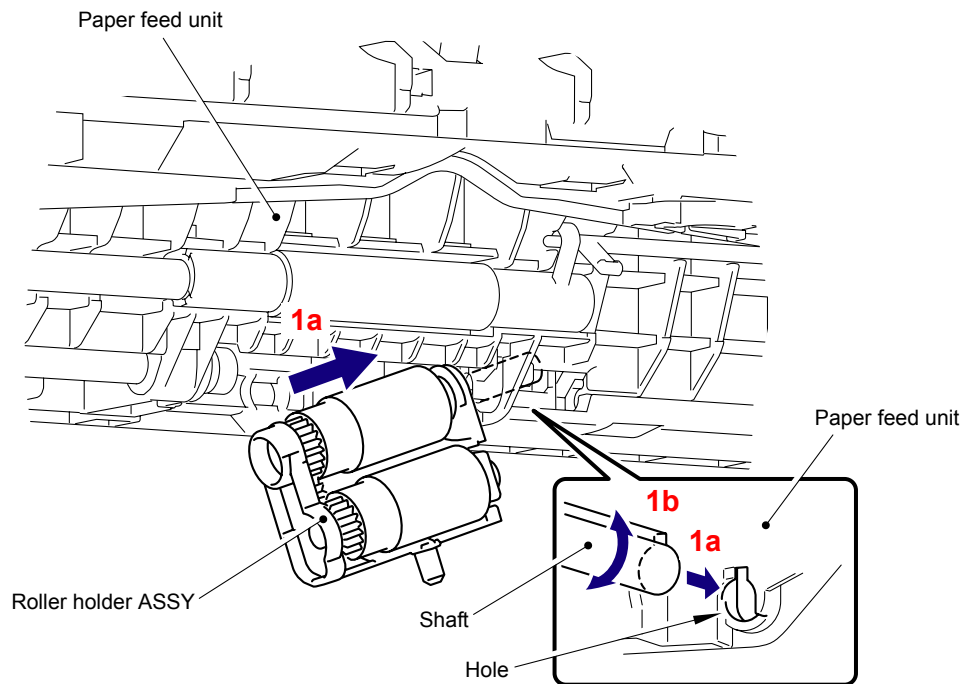

Fig. 4-28

**<Installing procedure>**

- (1) Align the shaft of the roller holder ASSY to the hole of the Paper feed unit and insert it into the hole.



**Fig. 4-29**

- (2) Slide the Roller holder ASSY in the direction of the arrow 2a and 2b in this order, and fit the "B" of the Roller holder ASSY into the "A" of the Paper feed unit.

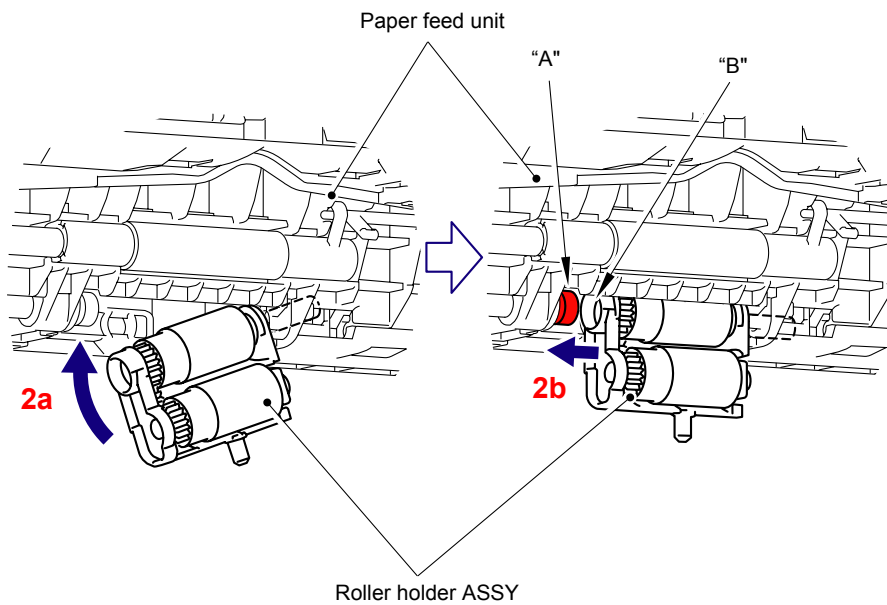

**Fig. 4-30**

- (3) Turn the Roller holder ASSY in the direction of the arrow 3a and insert the "D" of the Roller holder ASSY into the "C" of the Lift arm.

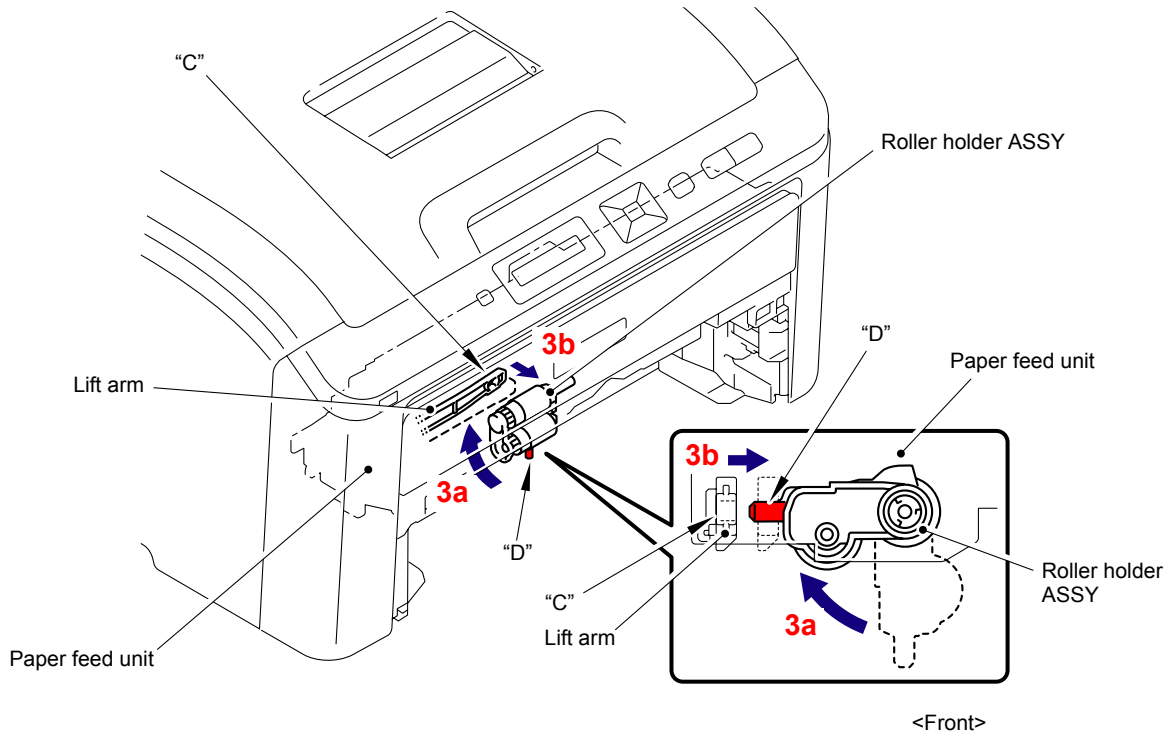

Fig. 4-31

- (4) Assemble the Pad spring onto the Paper tray.

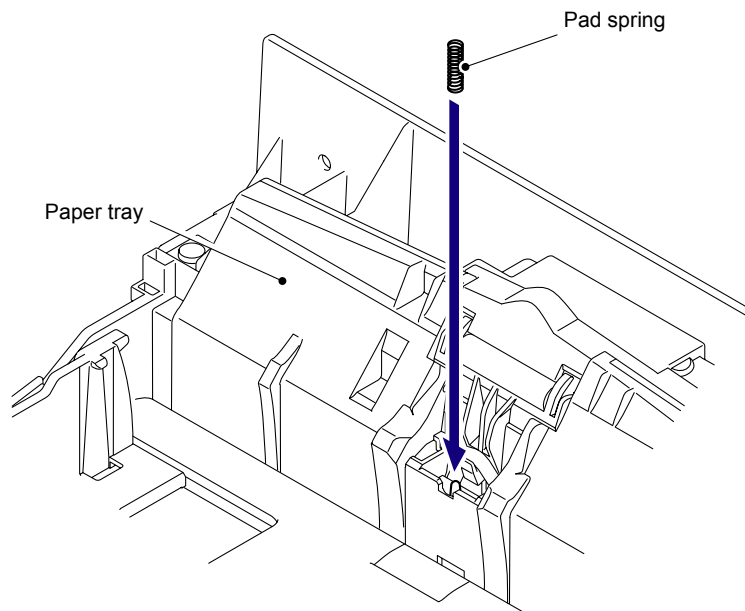

Fig. 4-32

- (5) Put the two Pins of the Separation pad ASSY into the Paper tray.

**Note:**

Apply grease to the separation pad ASSY before mounting the Paper tray.  
(Refer to "4. LUBRICATION" in Chapter 5.)

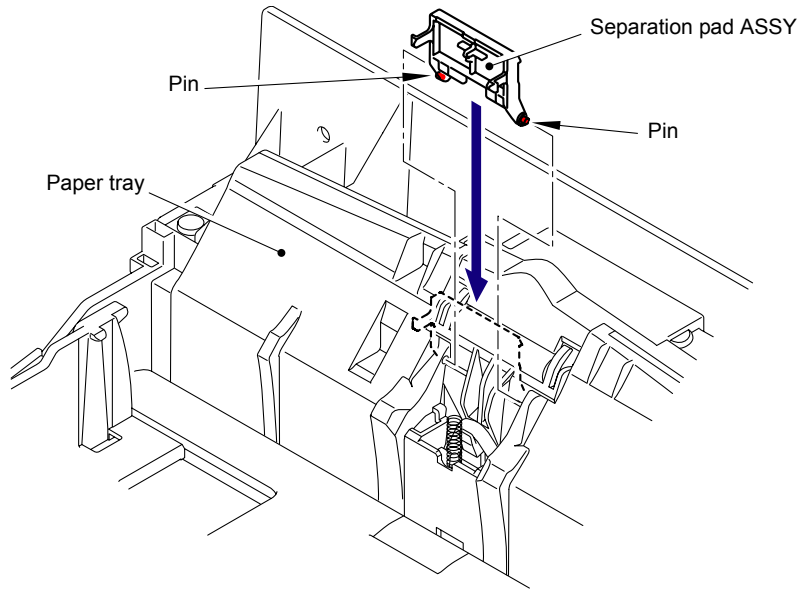

Fig. 4-33

- (6) Set the Pad spring in a way that the "E" of the Separation pad ASSY fits into the "F", and assemble the two Hooks of the Separation pad ASSY to the Paper tray.

**Note:**

Check that the Separation pad ASSY pivots up and down smoothly by pushing it gently.

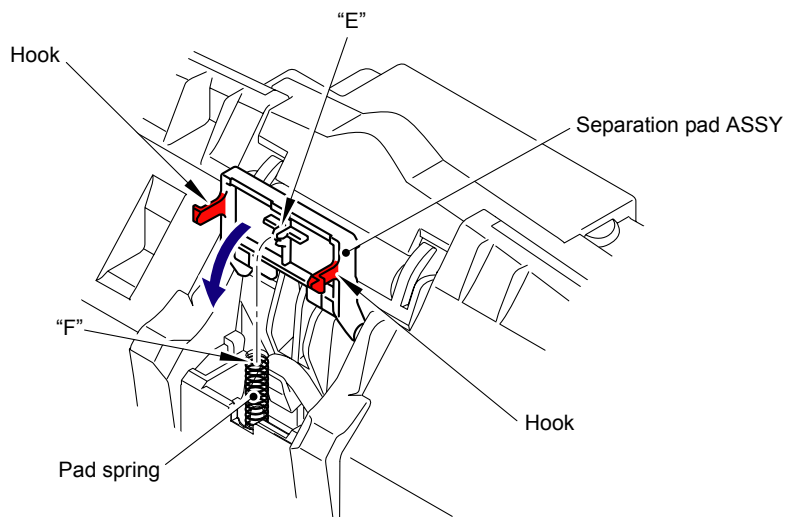

Fig. 4-34

- (7) After replacing the Paper feeding kit, reset the counter. (Refer to "2.3 Parts Life Reset Function" in Chapter 7.)

# **CHAPTER 5**

## **DISASSEMBLY AND ASSEMBLY**

# CHAPTER 5

## DISASSEMBLY AND ASSEMBLY

This chapter describes procedures for disassembling and assembling the machine with relates notes. The provided disassembly order flow enables you to take in the quickest way to get an involved part at a glance.

At the start of disassembling, you can check the disassembly order flow which guides you through a shortcut to get to the part.

This chapter also covers screw tightening torques and lubrication points where the specified lubrication should be applied when the machine is assembled.

### CONTENTS

<b>1. SAFETY PRECAUTIONS .....</b>	<b>5-1</b>
<b>2. PACKING.....</b>	<b>5-2</b>
<b>3. SCREW TORQUE LIST .....</b>	<b>5-3</b>
<b>4. LUBRICATION .....</b>	<b>5-5</b>
<b>5. OVERVIEW OF GEARS.....</b>	<b>5-7</b>
<b>6. HARNESS ROUTING.....</b>	<b>5-11</b>
<b>7. DISASSEMBLY FLOW.....</b>	<b>5-26</b>
<b>8. DISASSEMBLY PROCEDURE .....</b>	<b>5-27</b>
8.1 Support Flap .....	5-28
8.2 Roller Holder ASSY .....	5-29
8.3 Separation Pad ASSY .....	5-31
8.4 Back Cover/Back Cover Stopper L/R .....	5-33
8.5 Fuser Cover.....	5-36
8.6 Paper Eject Front Actuator .....	5-37
8.7 Fuser Unit .....	5-39
8.8 Side Cover L ASSY/Access Cover .....	5-43
8.9 Side Cover R ASSY.....	5-46
8.10 Control Panel Cover ASSY.....	5-48
8.11 Wireless LAN PCB ASSY (HL-3070CW only) .....	5-50
8.12 Panel PCB ASSY .....	5-52
8.13 Rubber Key Printed ASSY.....	5-53
8.14 LCD/Back Light Film.....	5-54
8.15 USB Direct Interface Relay PCB ASSY (HL-3070CW only).....	5-56



8.16 Panel Light Guide .....	5-57
8.17 Front Cover.....	5-58
8.18 Manual Feed Slot ASSY .....	5-60
8.19 TC Arm Spring .....	5-61
8.20 Arm Guide L Cover.....	5-65
8.21 Top Cover Sub ASSY .....	5-66
8.22 Inner Chute 2 ASSY .....	5-69
8.23 FFC Harness:MAIN-LED CTL .....	5-70
8.24 LED Power Relay PCB ASSY .....	5-75
8.25 LED Head Control PCB ASSY .....	5-76
8.26 LED ASSY/Holder Hook .....	5-78
8.27 Z Spring L/Z Spring R .....	5-83
8.28 Develop Release Motor ASSY .....	5-85
8.29 Main PCB ASSY .....	5-87
8.30 Engine PCB ASSY .....	5-88
8.31 Main PCB Insulation Sheet/Engine Insulation Sheet.....	5-89
8.32 Main PCB Shield Plate .....	5-90
8.33 Engine Shield Plate .....	5-91
8.34 Registration Mark Relay PCB ASSY .....	5-92
8.35 Drum Develop Drive Unit.....	5-93
8.36 Develop Drive Motor .....	5-98
8.37 Paper Feed Motor ASSY .....	5-99
8.38 Paper Feed Unit .....	5-101
8.39 Registration Front/Rear Sensor PCB ASSY .....	5-104
8.40 Manual Sensor PCB ASSY .....	5-106
8.41 Pick-up Sector Gear Spring/Friction Spring .....	5-107
8.42 PF Registration Solenoid.....	5-110
8.43 Pick-up Solenoid/Pick-up Solenoid Lever Spring .....	5-112
8.44 Fuser/Eject Drive Motor .....	5-114
8.45 Fuser/Eject Drive Motor Sensor PCB ASSY .....	5-115
8.46 Top Cover Arm R .....	5-116
8.47 Top Cover Arm L.....	5-117
8.48 Air Filter Holder ASSY/Ozone Filter .....	5-118
8.49 Paper Eject Rear Actuator/Paper Eject Rear Actuator Spring/Paper Eject Rear Actuator Top.....	5-121
8.50 Eject Rear Sensor PCB ASSY .....	5-124
8.51 Eject Front Sensor PCB ASSY .....	5-125
8.52 Toner/New Sensor PCB ASSY .....	5-126
8.53 Belt Drive ASSY .....	5-127

8.54 Drum Motor Origin Sensor PCB ASSY .....	5-128
8.55 LV Fan ASSY .....	5-129
8.56 Main Fan ASSY .....	5-131
8.57 Low-voltage Power Supply PCB ASSY .....	5-132
8.58 Registration Sensor Holder ASSY .....	5-137
8.59 High-voltage Power Supply PCB ASSY .....	5-138
8.60 HVPS Control PCB ASSY .....	5-144
8.61 Waste Toner Sensor .....	5-145
8.62 Develop Release Sensor PCB ASSY .....	5-148
8.63 Belt Cleaner Spring.....	5-149
8.64 TR Head Spring .....	5-153
8.65 Side Frame R .....	5-155
8.66 Toner LED PCB ASSY/LED Holder .....	5-158
8.67 LM Hook B/LM Hook C/Hook Spring BC10 .....	5-159

# 1. SAFETY PRECAUTIONS

To avoid creating secondary problems by mishandling, follow the warnings and precautions below during maintenance work.

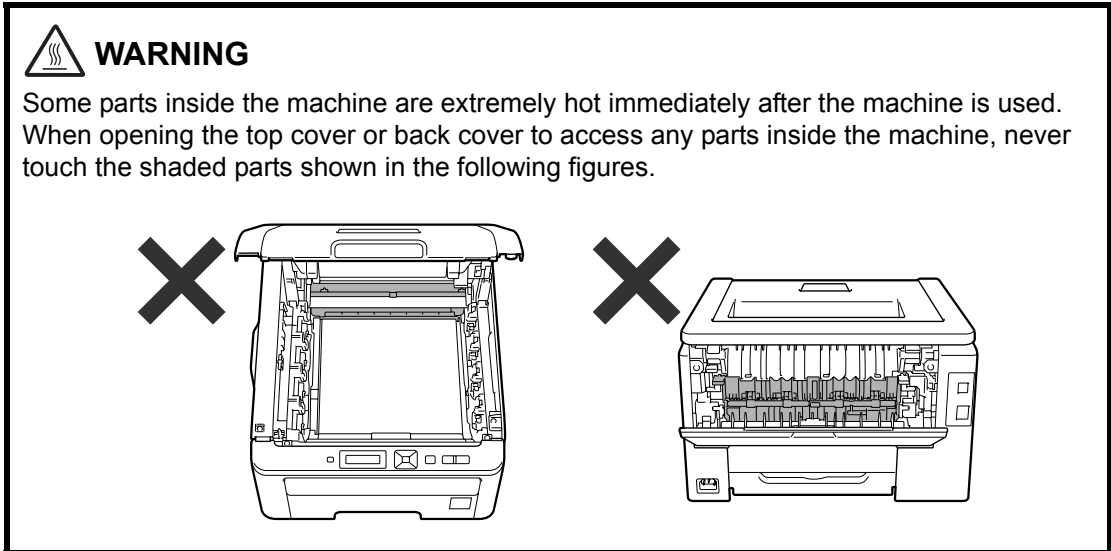

## Caution:

- Be careful not to lose screws, washers, or other parts removed.
- Be sure to apply grease to the gears and applicable positions specified in this chapter.
- When using soldering irons or other heat-generating tools, take care not to accidentally damage parts such as wires, PCBs and covers.
- Static electricity charged in your body may damage electronic parts. When transporting PCBs, be sure to wrap them in conductive sheets.
- When replacing the PCB and all the other related parts, put on a grounding wrist band and perform the job on a static mat. Also take care not to touch the conductor sections on the flat cables or on the wire harness.
- After disconnecting flat cables, check that each cable is not damaged at its end or shortcircuited.
- When connecting flat cables, do not insert them at an angle. After insertion, check that the cables are not at an angle.
- When connecting or disconnecting cable connectors, hold the connector body, not the cables. If the connector has a lock, release the connector lock first to release it.
- After a repair, check not only the repaired portion but also all connectors. Also check that other related portions are functioning properly before operational checks.
- Violently closing the top cover without mounting the toner cartridge and the drum unit can damage this product.

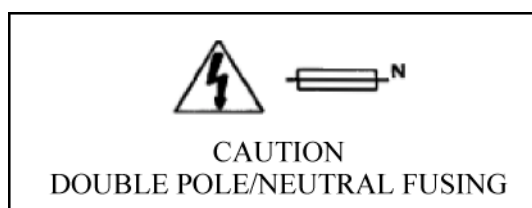

# 2. PACKING

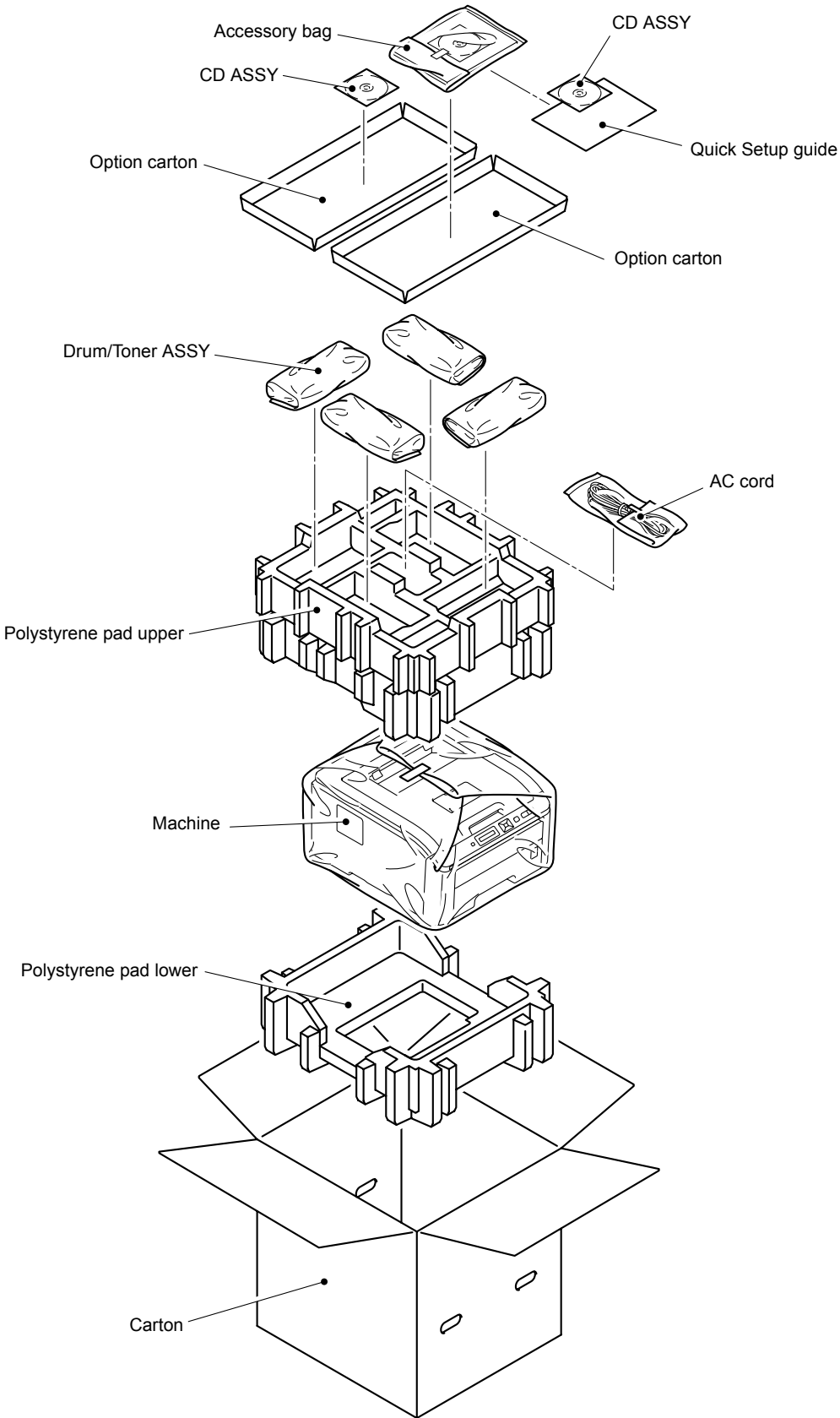

### 3. SCREW TORQUE LIST

**Note:**

For verifying the shape of each screw, refer to “APPENDIX 4 SCREW CATALOGUE”.

Location of screw	Screw type	Q'ty	Tightening torque N·m (kgf·cm)
Fuser cover L	Taptite bind B M3x12	1	0.60±0.10 (6±1)
Fuser cover R	Taptite bind B M3x12	1	0.60±0.10 (6±1)
Fuser unit	Taptite pan B M4x14	2	0.80±0.10 (8±1)
Side cover L ASSY	Taptite bind B M4x12	2	0.90±0.10 (9±1)
Side cover R ASSY	Taptite bind B M4x12	2	0.90±0.10 (9±1)
Main shield cover plate ASSY	Taptite cup S M3x6 SR	4	0.50±0.10 (5±1)
LED FG harness ASSY			
Control panel cover ASSY	Taptite bind B M4x12	2	0.90±0.10 (9±1)
USB direct interface relay PCB ASSY	Taptite bind B M3x8	2	0.50±0.10 (5±1)
FG harness			
USB holder	Taptite bind B M3x8	2	0.50±0.10 (5±1)
Front cover	Taptite bind B M4x12	2	0.90±0.10 (9±1)
Inner chute 2 ASSY	Taptite bind B M4x12	2	0.90±0.10 (9±1)
Arm guide L	Taptite bind B M4x12	2	0.90±0.10 (9±1)
TC harness cover	Taptite bind B M4x12	1	0.90±0.10 (9±1)
Arm guide R	Taptite bind B M4x12	2	0.90±0.10 (9±1)
Sub frame ASSY	Taptite bind B M4x12	3	0.90±0.10 (9±1)
LED PCB cover	Taptite cup S M3x6 SR	4	0.50±0.10 (5±1)
LED head control PCB ASSY	Taptite cup S M3x6 SR	4	0.50±0.10 (5±1)
Develop release motor ASSY	Taptite bind S M3x5	1	0.70±0.10 (7±1)
Main PCB ASSY	Taptite cup S M3x6 SR	4	0.50±0.10 (5±1)
Engine PCB ASSY (front side)	Taptite cup S M3x6 SR	2	0.80±0.10 (8±1)
Engine PCB ASSY (rear side)	Taptite cup S M3x6 SR	2	0.50±0.10 (5±1)
Main PCB shield plate	Taptite bind B M4x12	1	0.90±0.10 (9±1)
	Taptite cup S M3x6 SR	3	0.80±0.10 (8±1)
Engine shield plate	Taptite bind B M4x12	1	0.90±0.10 (9±1)
	Taptite cup S M3x6 SR	1	0.80±0.10 (8±1)
Develop drive plate ASSY	Taptite cup S M3x6 SR	2	0.80±0.10 (8±1)
	Taptite bind B M4x12	2	0.90±0.10 (9±1)
Under bar	Taptite bind B M4x12	4	0.90±0.10 (9±1)
Under bar earth plate	Taptite cup S M3x6 SR	1	0.80±0.10 (8±1)
Drum develop drive unit	Taptite bind B M4x12	3	0.90±0.10 (9±1)
	Taptite cup S M3x6 SR	2	0.80±0.10 (8±1)
Develop drive motor	Screw bind M3x4	3	0.50±0.05 (5±0.5)
Paper feed motor ASSY	Screw bind M3x4	3	0.50±0.05 (5±0.5)

Location of screw	Screw type	Q'ty	Tightening torque N·m (kgf·cm)
Paper feed unit	Taptite cup S M3x6 SR	3	0.80±0.10 (8±1)
	Shoulder screw	2	0.80±0.10 (8±1)
PF upper cover ASSY	Taptite cup B M3x10	2	0.60±0.10 (6±1)
Registration front/rear sensor PCB ASSY	Taptite cup B M3x8	1	0.55±0.05 (5.5±0.5)
Front chute ASSY	Taptite cup B M3x10	2	0.60±0.10 (6±1)
Cleaner PF gear cover	Taptite bind B M4x12	5	0.90±0.10 (9±1)
PF registration solenoid	Taptite bind B M3x10	1	0.55±0.10 (5.5±1)
Pick-up solenoid	Taptite bind B M3x10	1	0.55±0.10 (5.5±1)
Fuser/eject drive motor	Taptite bind B M4x12	1	0.90±0.10 (9±1)
	Taptite cup S M3x6 SR	1	0.80±0.10 (8±1)
Eject gear cover	Taptite bind B M4x12	2	0.90±0.10 (9±1)
Paper eject guide ASSY	Taptite bind B M4x12	4	0.90±0.10 (9±1)
Belt drive ASSY	Taptite pan (washer) B M4x12DA	3	0.70±0.10 (7±1)
Drum motor origin sensor PCB ASSY	Taptite bind B M3x10	1	0.55±0.10 (5.5±1)
Safety louver	Taptite bind B M4x12	1	0.80±0.10 (8±1)
FG harness	Screw pan (S/P washer) M4x8 DB	1	0.80±0.10 (8±1)
LVPS unit	Taptite bind B M4x12	2	0.90±0.10 (9±1)
	Taptite cup S M3x6 SR	2	0.50±0.10 (5±1)
LVPS plate	Taptite pan (washer) B M4x12DA	4	0.90±0.10 (9±1)
Low-voltage power supply PCB ASSY, LVPS inner plate	Taptite pan (washer) B M4x12DA	1	0.90±0.10 (9±1)
Registration sensor holder ASSY	Taptite cup S M3x6 SR	1	0.50±0.10 (5±1)
High-voltage power supply PCB ASSY	Taptite bind B M4x12	2	0.70±0.10 (7±1)
	Taptite pan (washer) B M4x12DA	2	0.65±0.10 (6.5±1)
HVPS ground plate 2	Taptite cup S M3x6 SR	1	0.80±0.10 (8±1)
HVPS control PCB ASSY	Taptite pan (S/P W) B M3x10	1	0.40±0.05 (4±0.5)
Develop release sensor PCB ASSY	Taptite cup B M3x8	1	0.40±0.05 (4±0.5)
Side frame R	Shoulder screw M3	4	0.80±0.10 (8±1)
Side frame L	Shoulder screw M3	3	0.80±0.10 (8±1)
	Taptite cup S M3x6 SR	1	0.80±0.10 (8±1)
Bevel gear cover	Taptite bind B M4x12	3	0.90±0.10 (9±1)

## 4. LUBRICATION

The kind of the lubricating oil (Maker name)	Lubrication point	Quantity of lubrication
MOLYKOTE PG-661 (W) (Dow Corning)	Belt drive gear	2 mm dia. ball (PG2)
	LED ASSY	1 mm dia. ball (PG1)
FLOIL BG-MU (Kanto Kasei)	Belt drive gear	2 mm dia. ball (BG2)
MOLYKOTE EM-D110 (Dow Corning)	Separation pad ASSY	2 mm dia. ball (EM2)
	Paper tray	2 mm dia. ball (EM2)

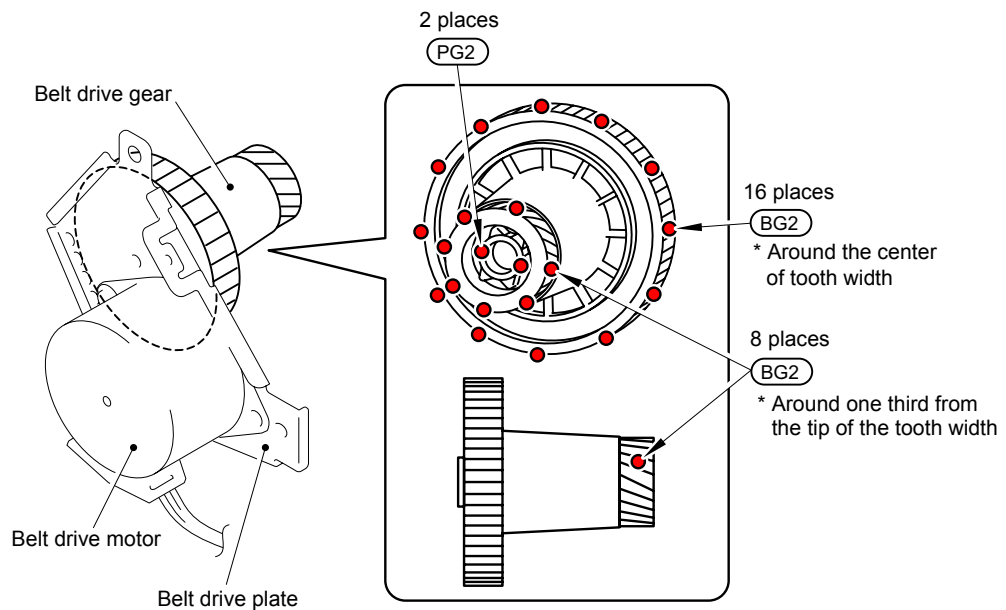

PG2: MOLYKOTE PG-661 (W) (2 mm dia. ball)  
BG2: FLOIL BG-MU (2 mm dia. ball)

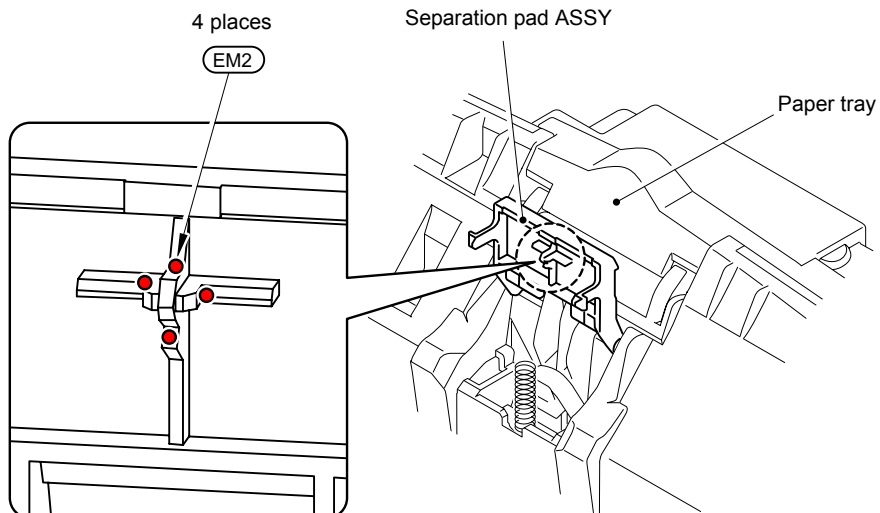

EM2: MOLYKOTE EM-D110 (2 mm dia. ball)

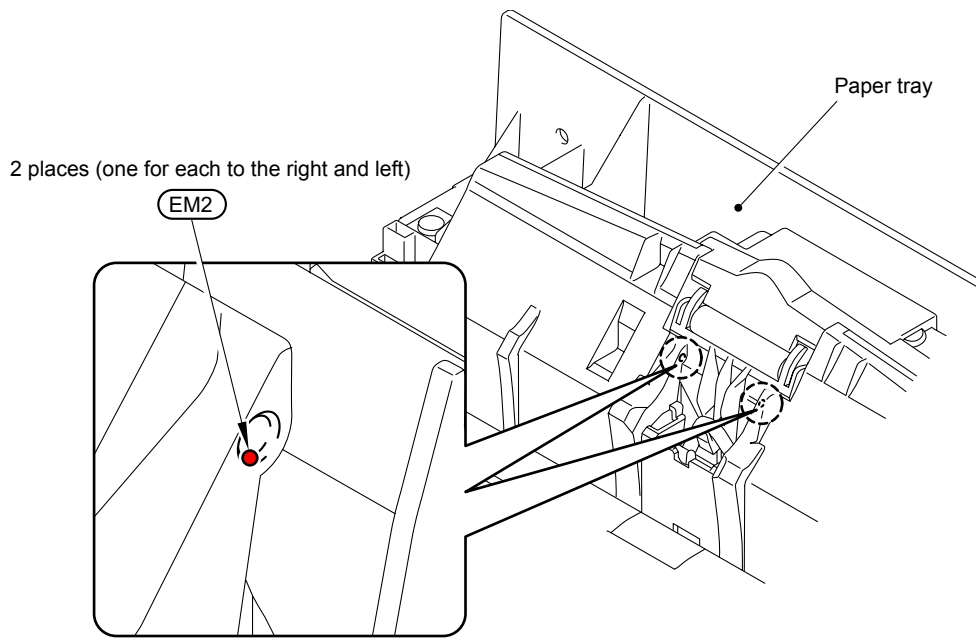

EM2: MOLYKOTE EM-D110 (2 mm dia. ball)

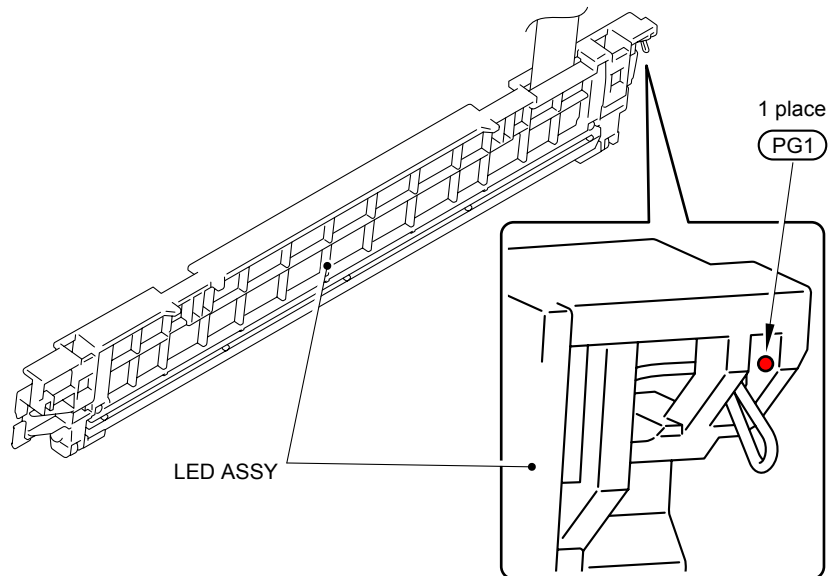

PG1: MOLYKOTE PG-661 (W) (1 mm dia. ball)



# 5. OVERVIEW OF GEARS

When ordering spare parts, please refer to Parts reference list.

## ■ Develop drive

### <Development view>

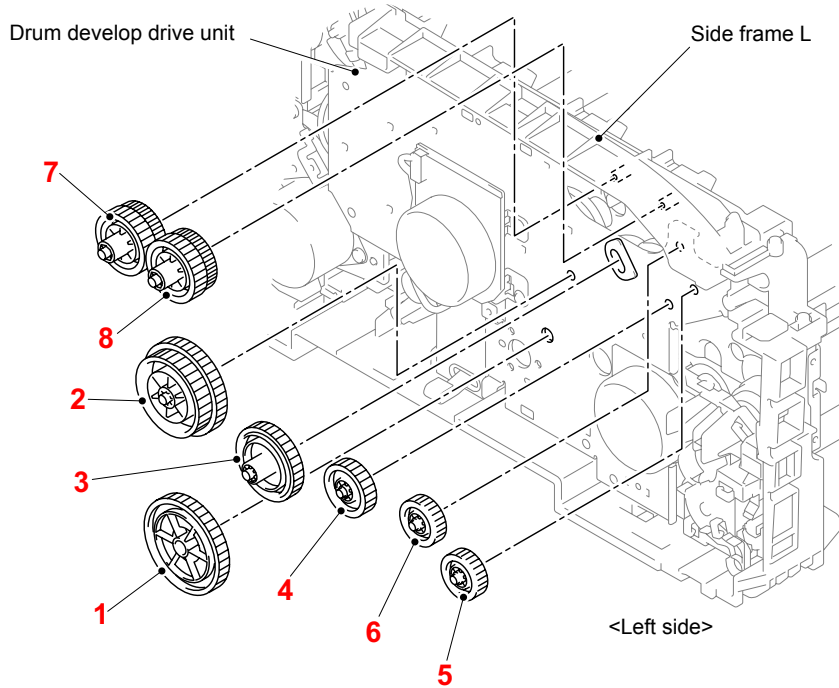

### <Layout view>

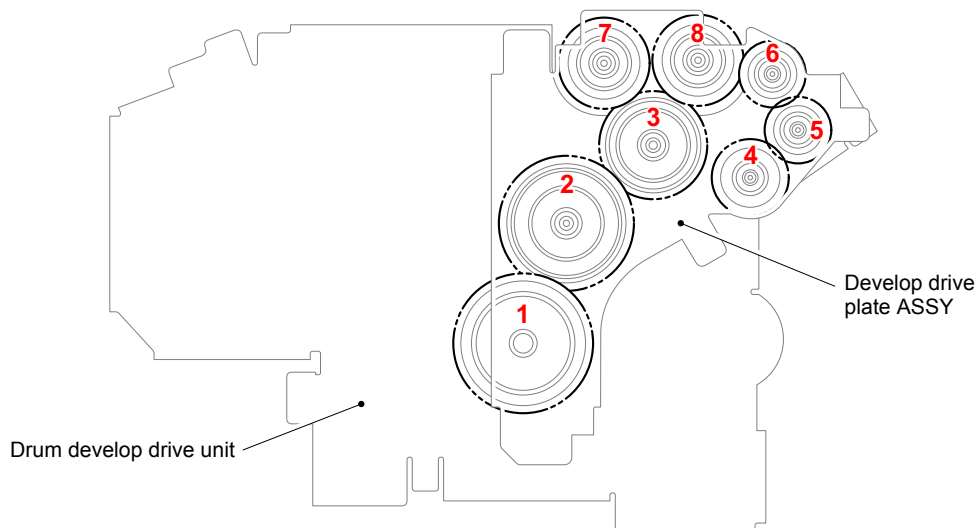

### <Name of gears>

1	LU5128	Idle gear 100	5	LU5126	Idle gear 30
2	LU5127	Gear 63/85	6	LU5126	Idle gear 30
3	LU5124	Pendulum gear 50	7	LU5143	Gear 42/39
4	LU5125	Idle gear 35	8	LU5143	Gear 42/39

\* These parts are subject to change without notice.

■ Drum develop drive

<Development view>

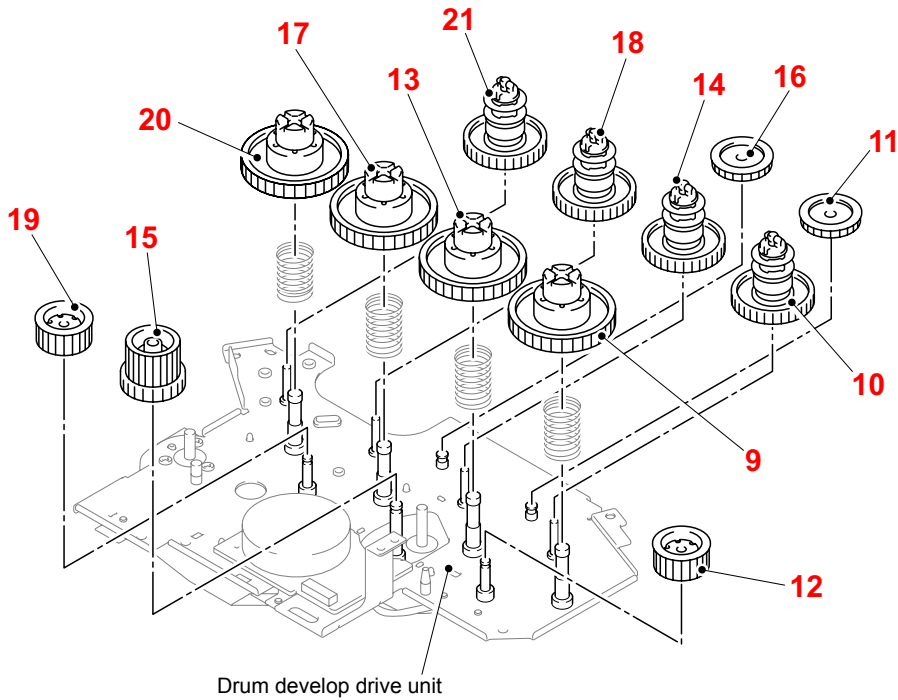

<Layout view>

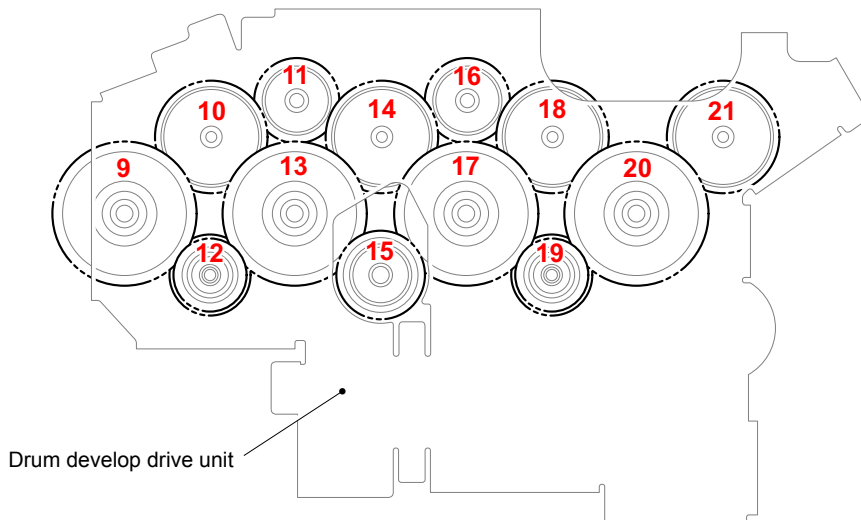

<Name of gears>

9	LU5139	Drum drive gear ASSY	16	LU5136	Coupling idle gear 35
10	LU5132	Develop coupling gear	17	LU6157	Drum drive gear 60
11	LU5136	Coupling idle gear 35	18	LU5132	Develop coupling gear
12	LU6158	Drum idle gear 30	19	LU6158	Drum idle gear 30
13	LU6157	Drum drive gear 60	20	LU6157	Drum drive gear 60
14	LU5132	Develop coupling gear	21	LU5132	Develop coupling gear
15	LU6159	Drum drive gear 62/30			

\* These parts are subject to change without notice.

■ Cleaner PF

<Development view>

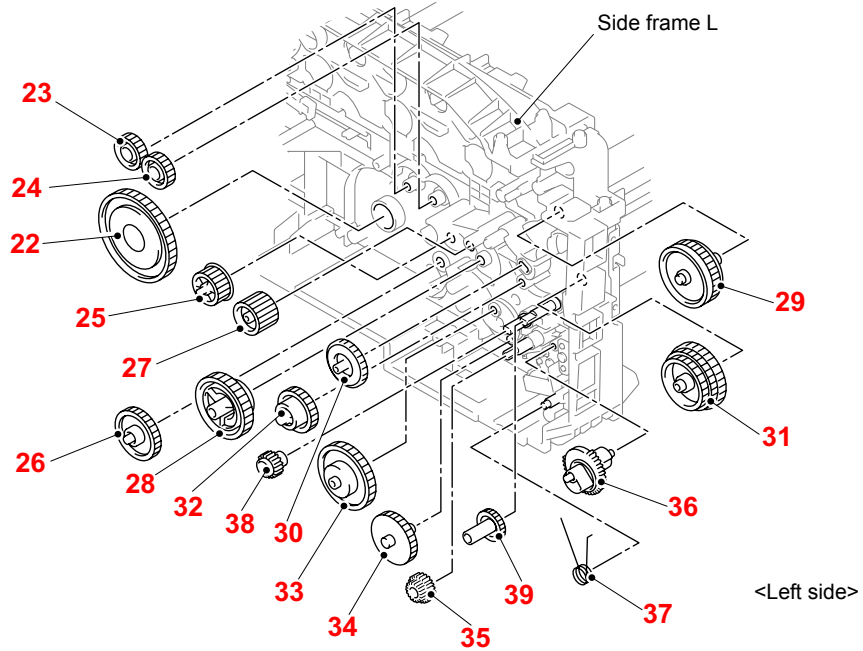

<Layout view>

\* Outside of side frame L

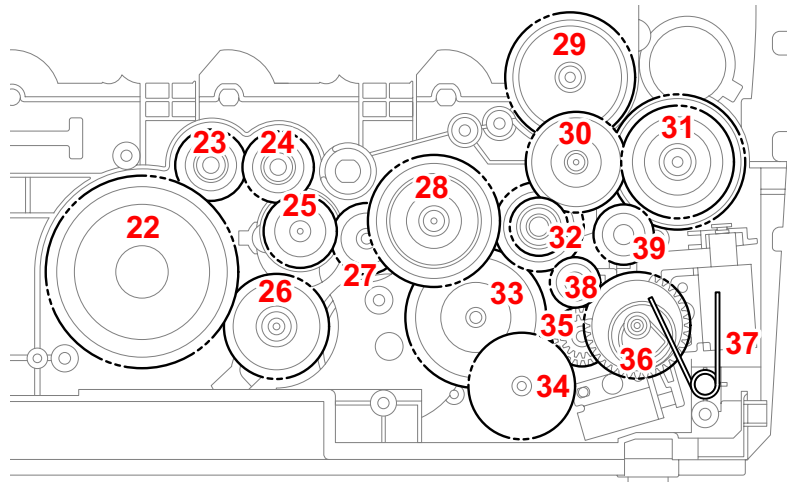

<Name of gears>

22	LU5108	Gear 70	31	LU5744	Registration differential gear
23	LU5110	Idle gear 25 R	32	LU5097	Gear 32/21
24	LU5110	Idle gear 25 R	33	LU5100	Gear 26-51
25	LU5112	Idle gear 25 SW	34	LU5101	Idle gear 40
26	LU5109	Idle gear 38	35	LU2043	Feeder gear 17/22
27	LU5111	Idle gear 25	36	LU5103	Pick-up sector gear 31/38
28	LU5161	Gear 27/72	37	LU5104	Pick-up sector gear spring
29	LU5069	Planetary clutch ASSY	38	LU5222	Feeder gear 17
30	LU5099	Pendulum gear 38	39	LU5223	PF drive gear 23

\* These parts are subject to change without notice.

■ PF drive

<Development view>

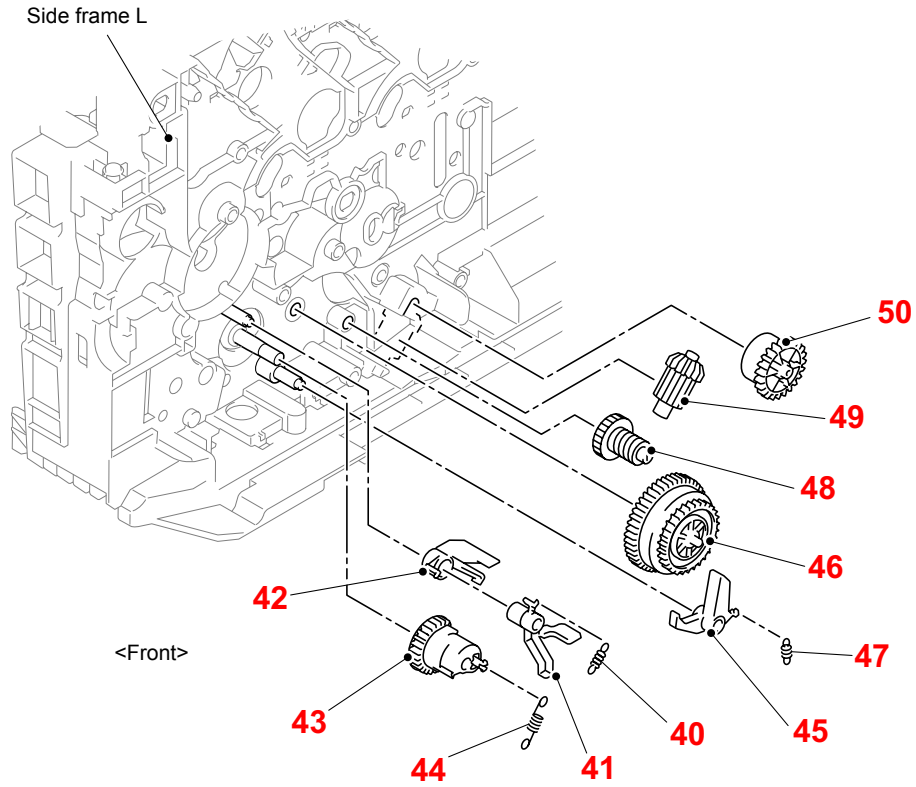

<Layout view>

\* Inside of side frame L

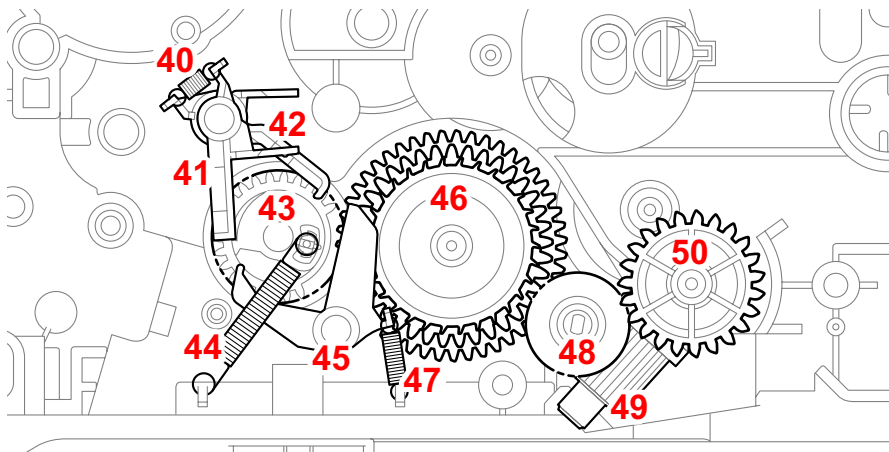

<Name of gears>

40	LR0910	Hook spring	46	LU5089	Planetary clutch ASSY
41	LU5093	LM hook B	47	LR0910	Hook spring
42	LU5094	LM hook C	48	LU5105	Worm Z33
43	LU5095	P/P gear 26 sector	49	LU5106	Bevel gear Z17G
44	LU6447	P/P gear 26 sector spring	50	LR0301	Bevel gear Z23G
45	LU5088	LM hook A			

\* These parts are subject to change without notice.

# 6. HARNESS ROUTING

## 1 Top Cover Unit

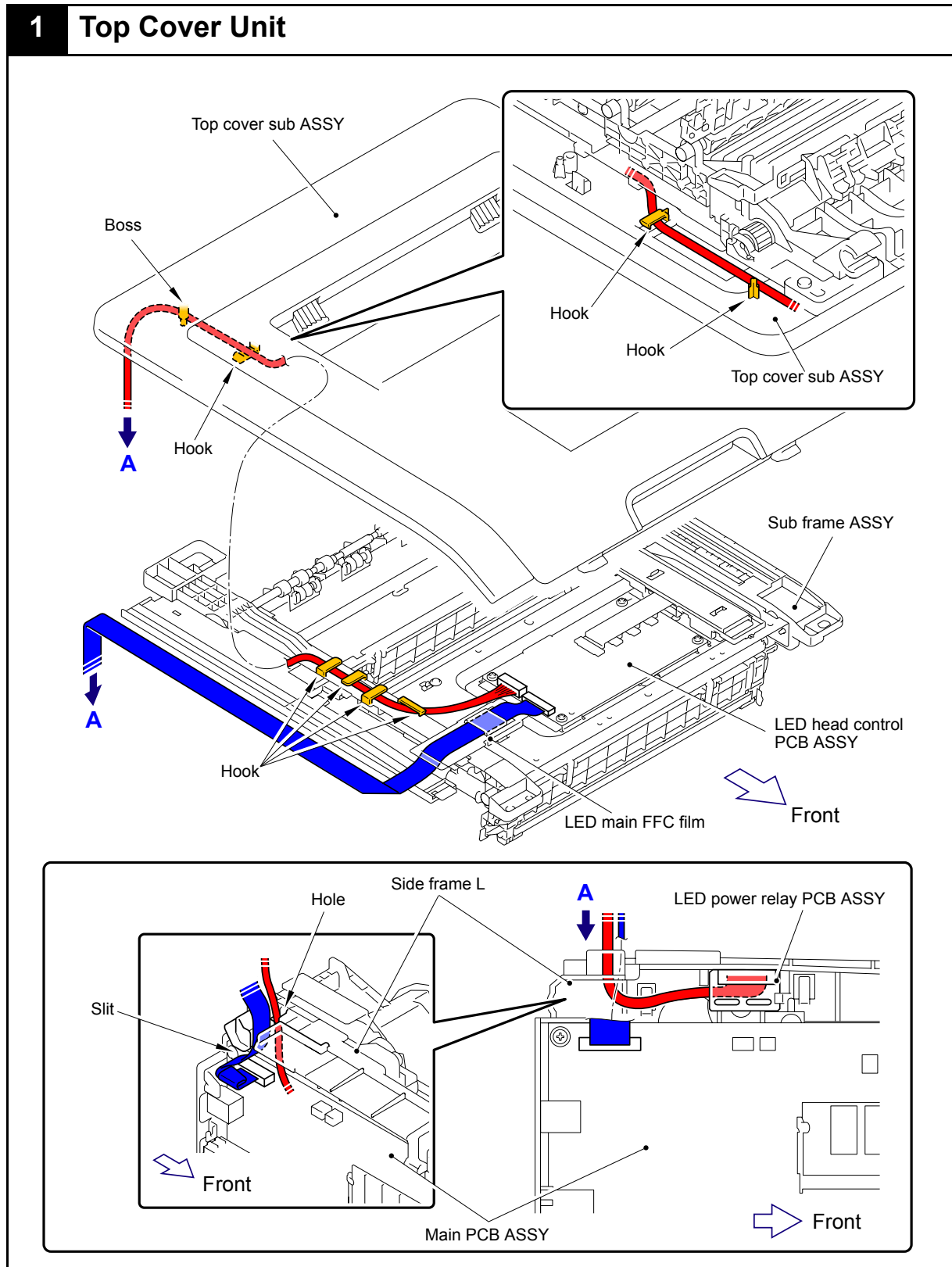

## 2 Registration Front/Rear Sensor PCB ASSY

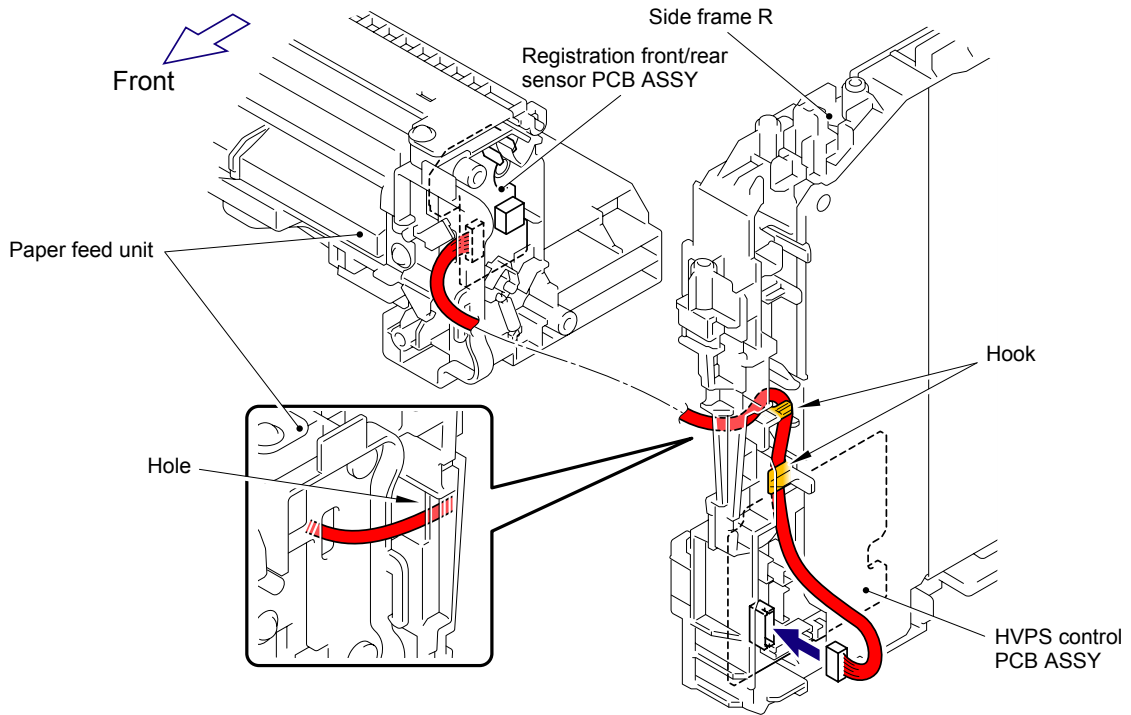

## 3 Manual Sensor PCB ASSY

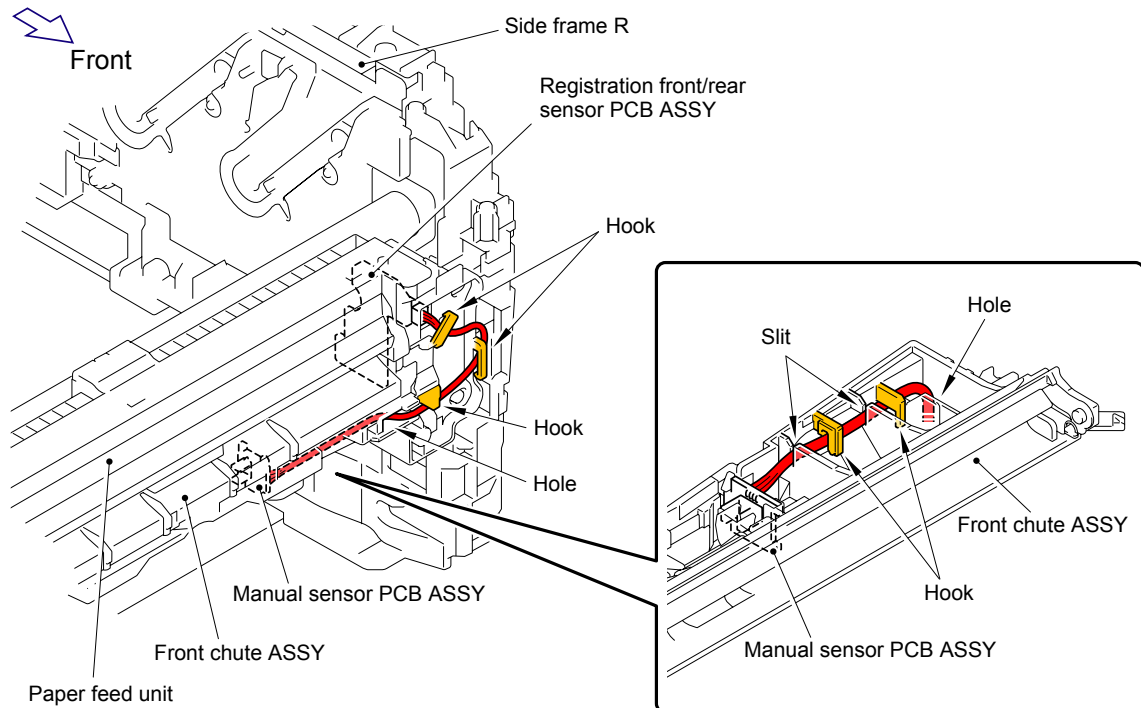

## 4 PF Registration Solenoid, Pick-up Solenoid

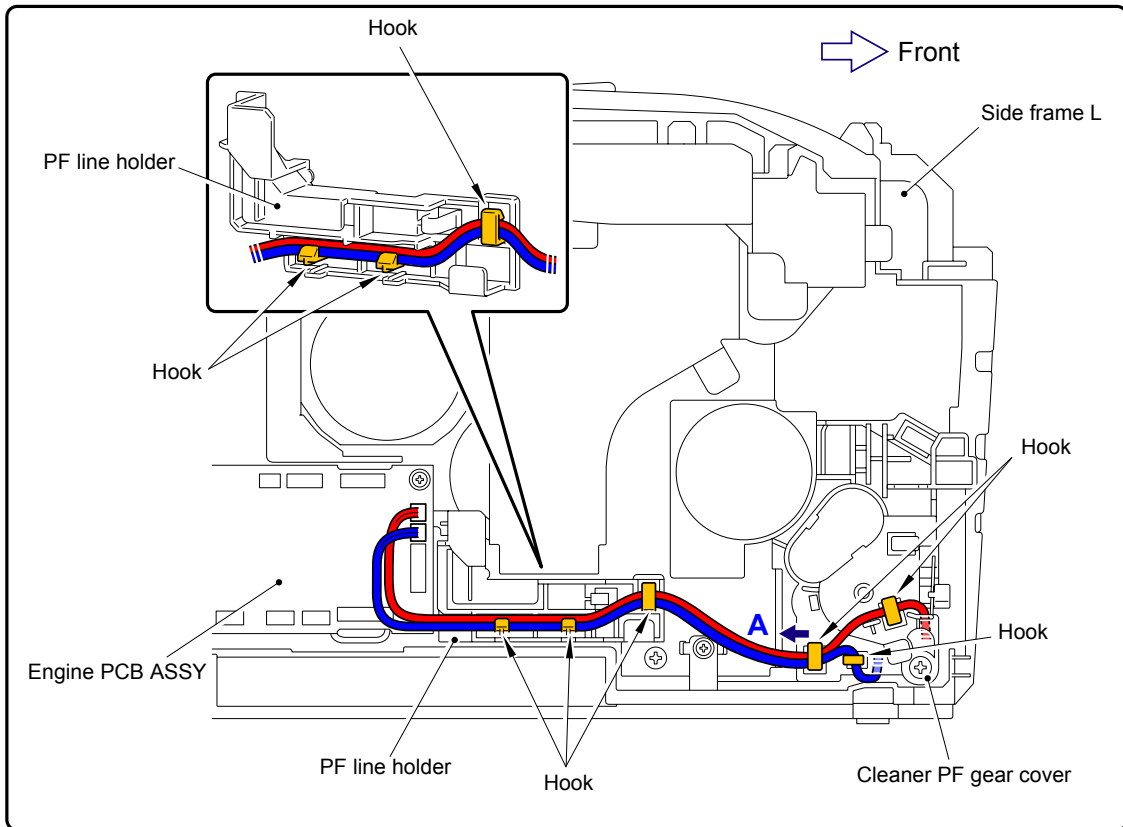
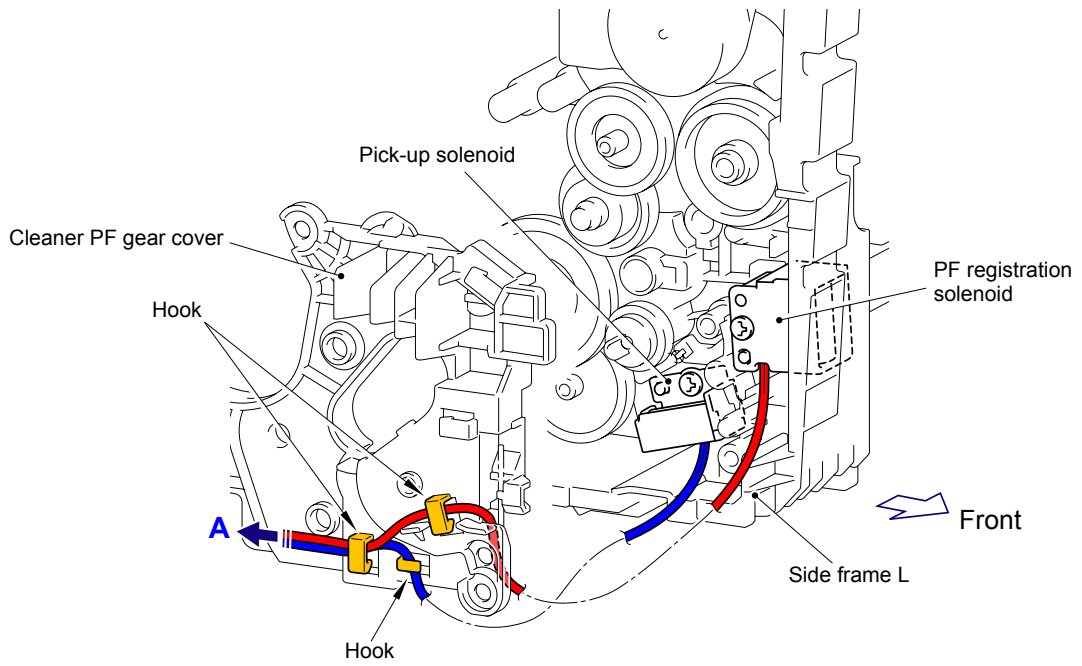

## 5 Belt Drive ASSY

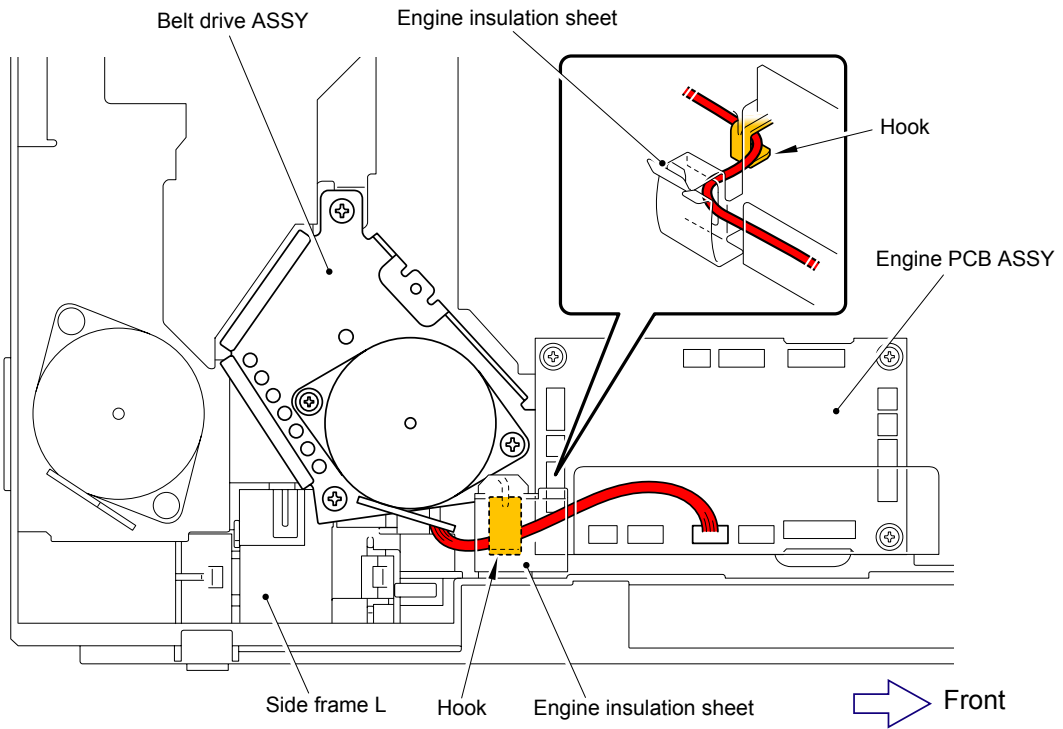

## 6 Develop Release Motor ASSY

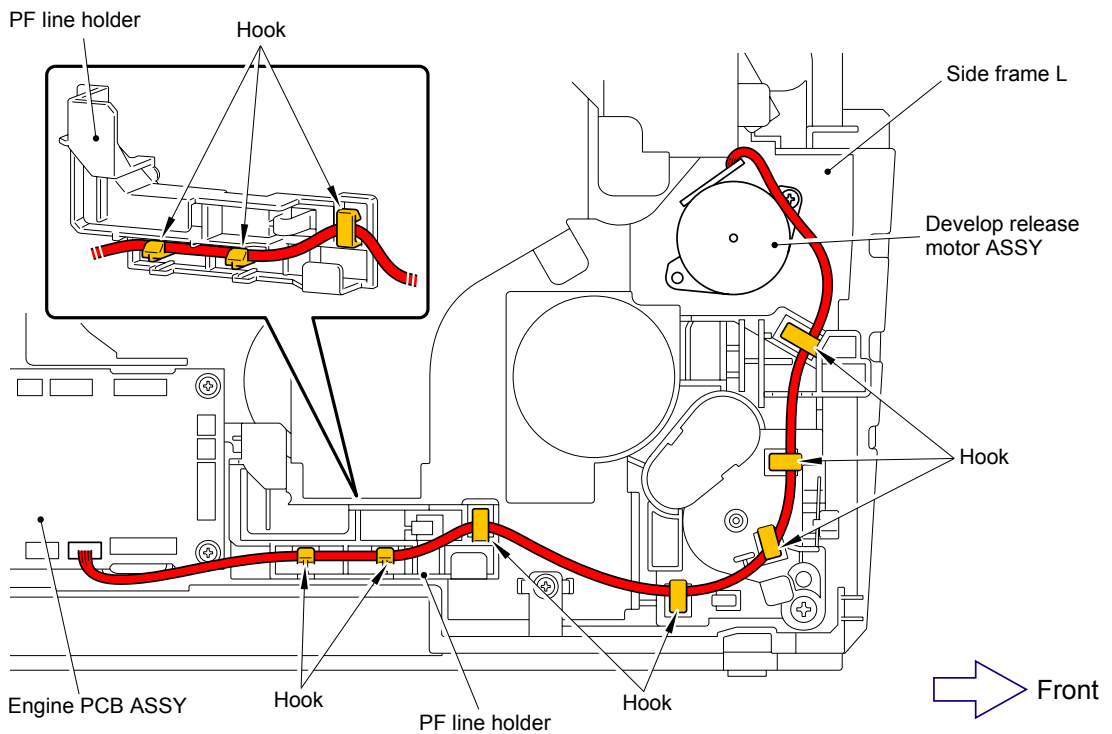



## 7 Drum Motor Origin Sensor PCB ASSY

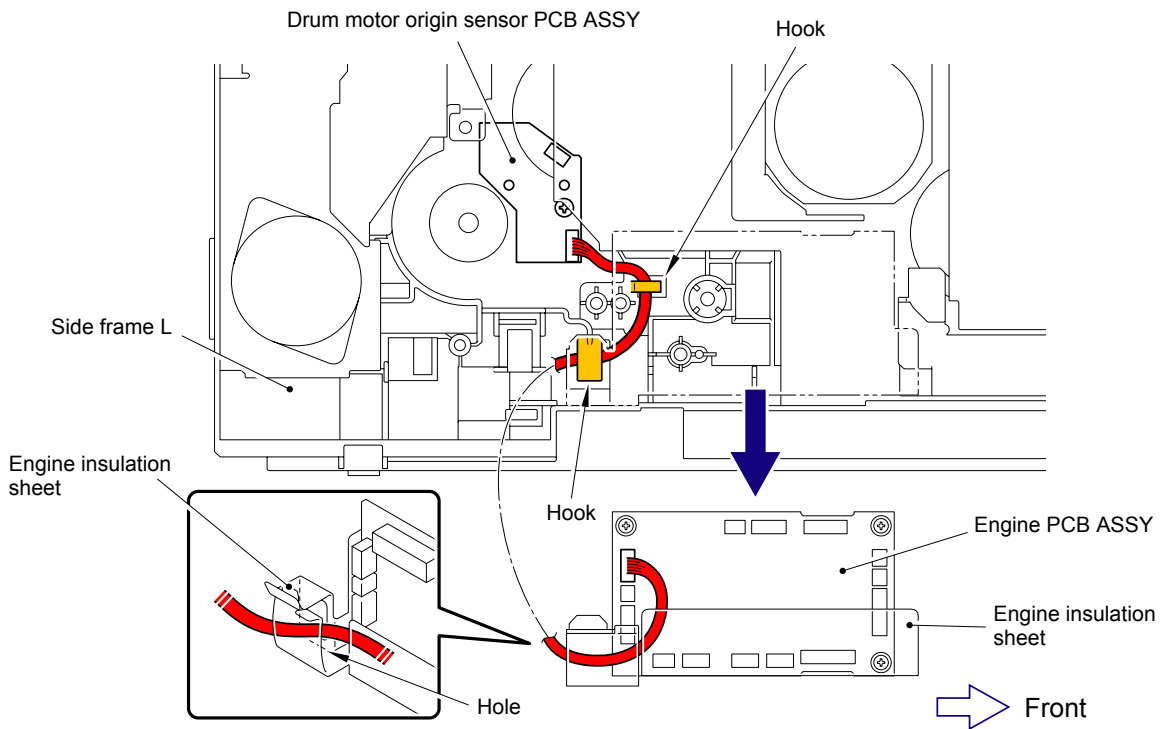

## 8 Fuser/Eject Drive Motor, Fuser/Eject Drive Motor Sensor PCB ASSY

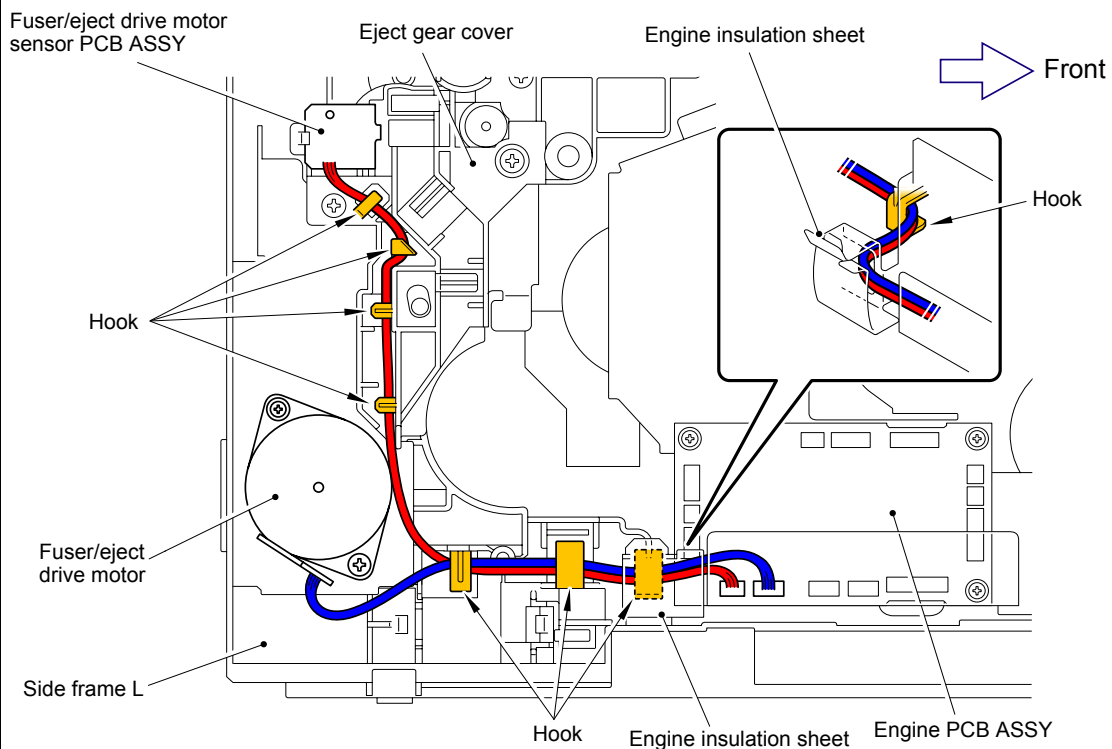

## 9 Toner/New Sensor PCB ASSY

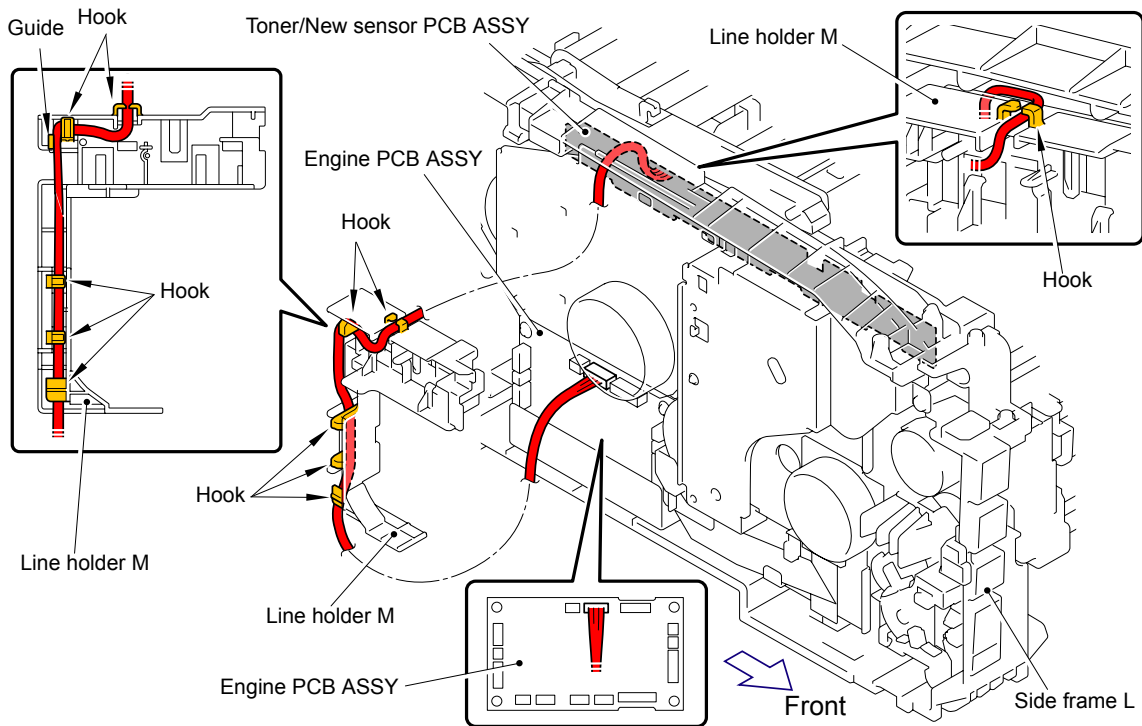

## 10 Paper Feed Motor ASSY, Drum Drive Motor

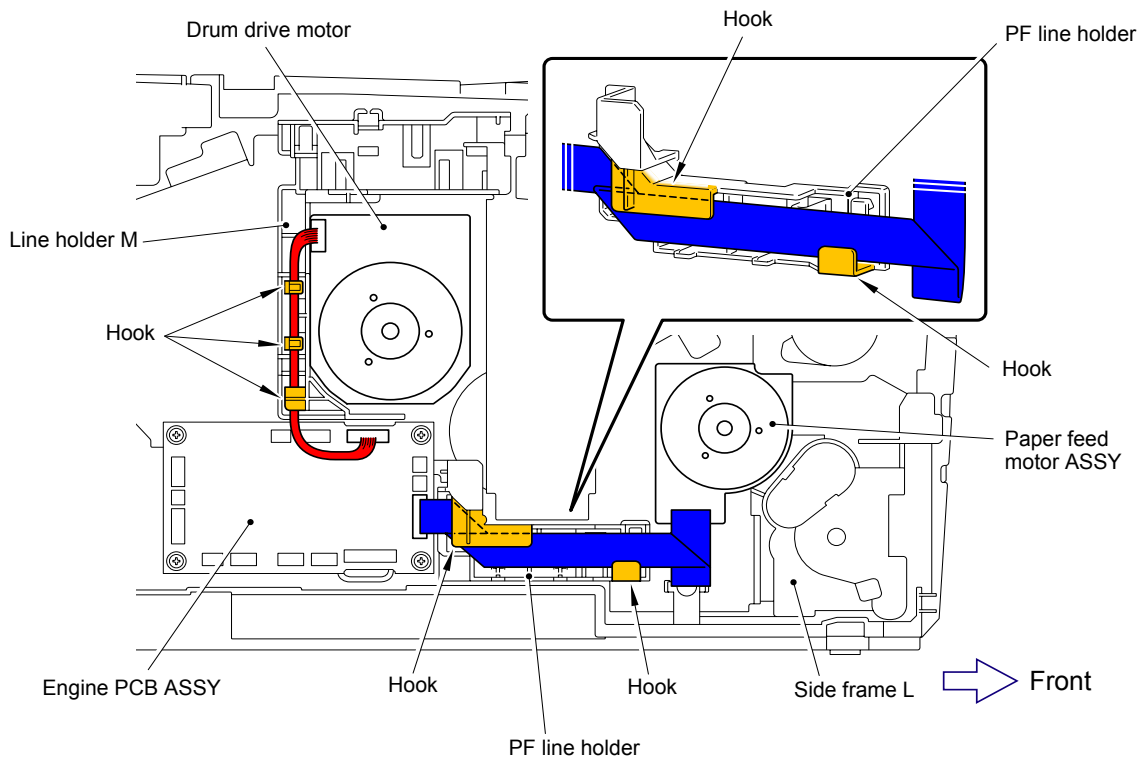

# 11 Control Panel Cover ASSY (HL-3070CW only) (USB Direct Interface Relay PCB ASSY)

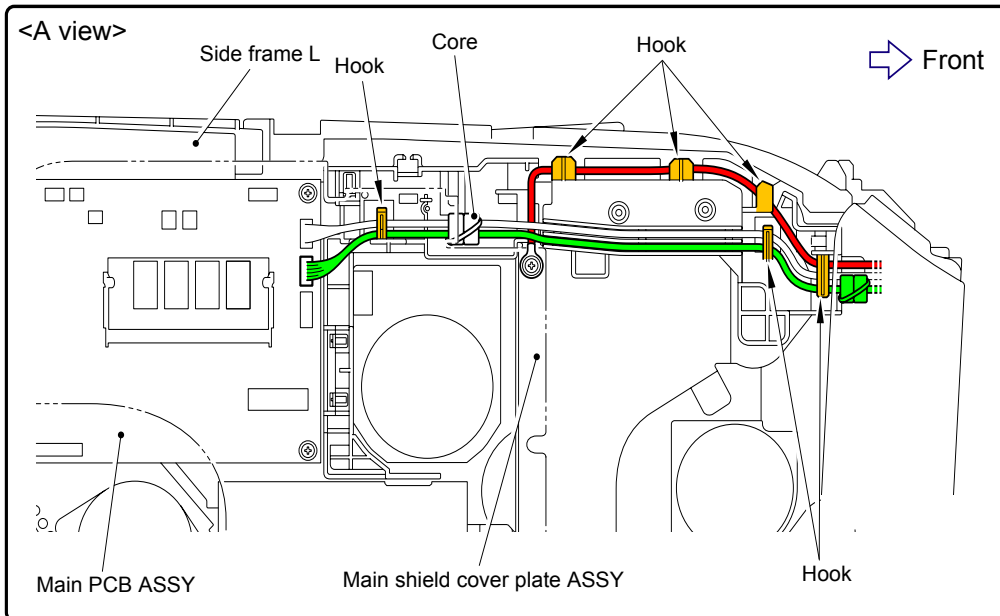
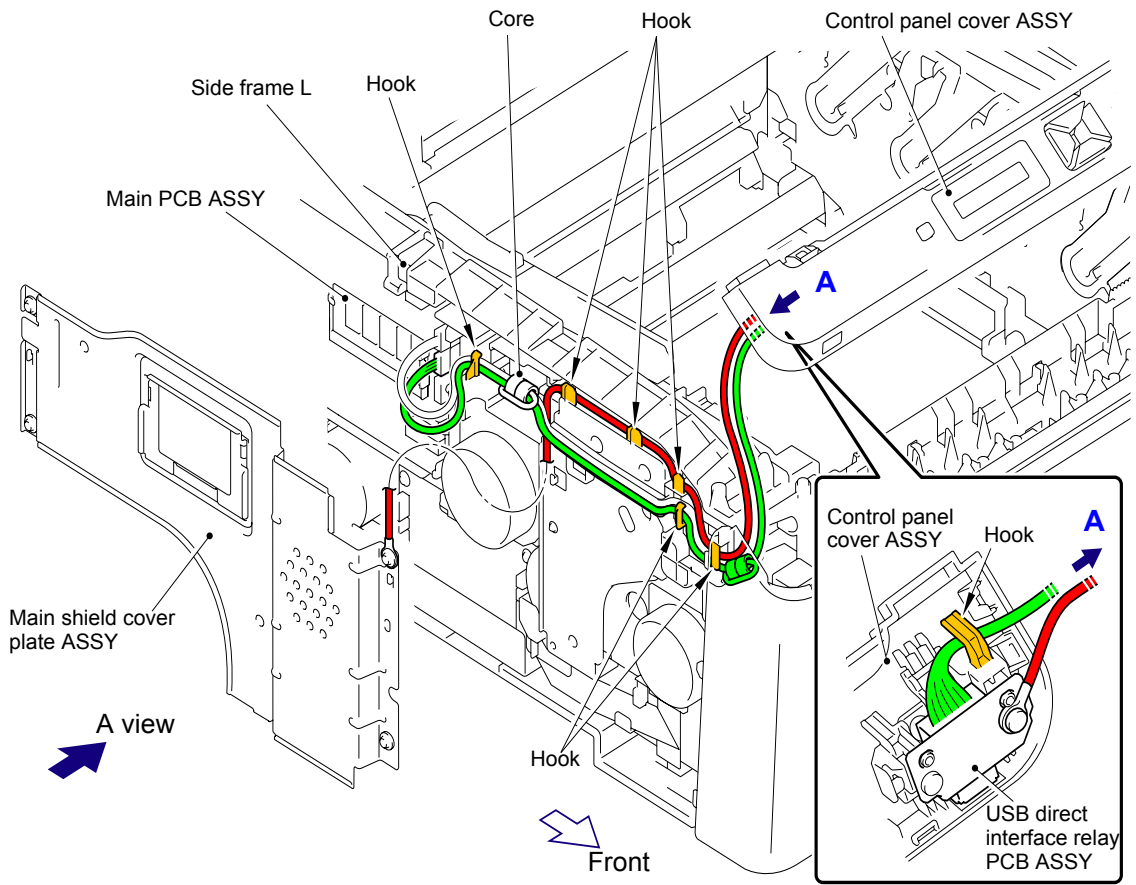

## 12 Control Panel Cover ASSY (HL-3070CW only) (Wireless LAN PCB ASSY, Panel PCB ASSY)

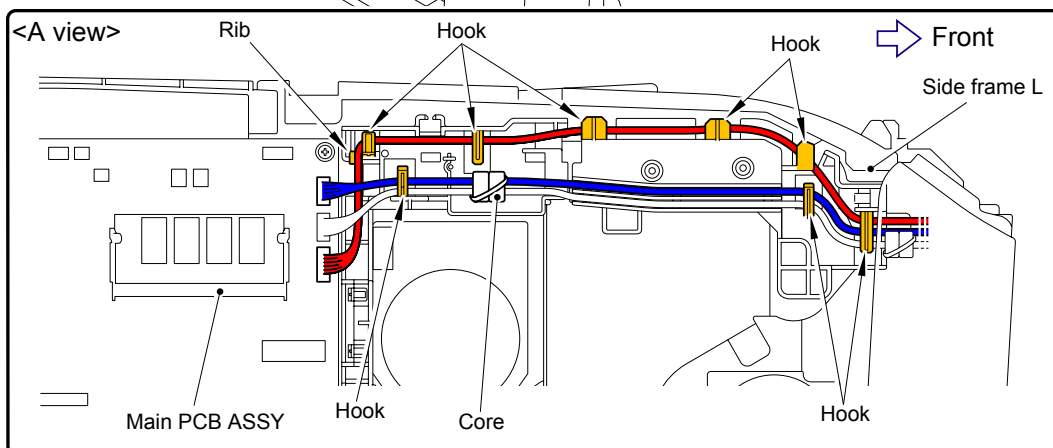
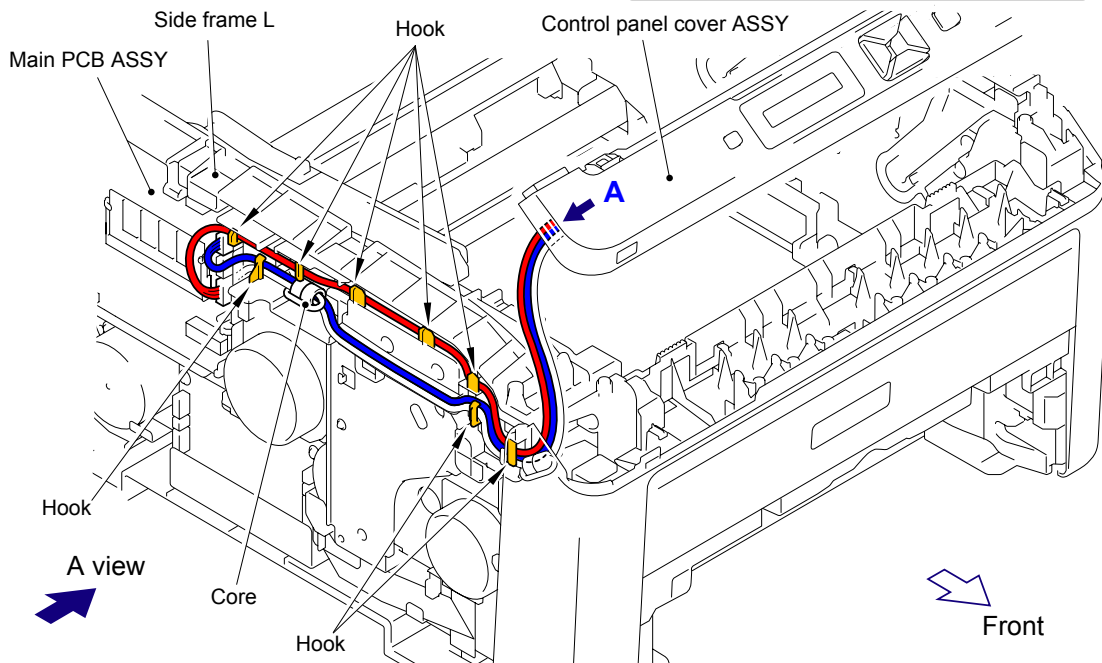
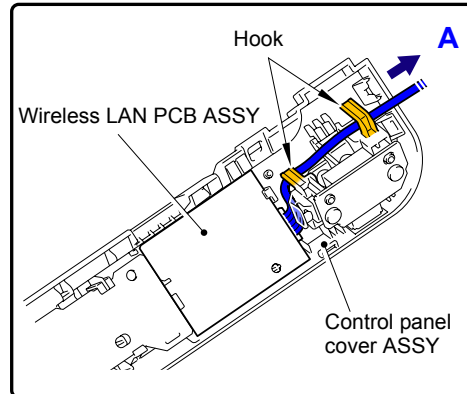
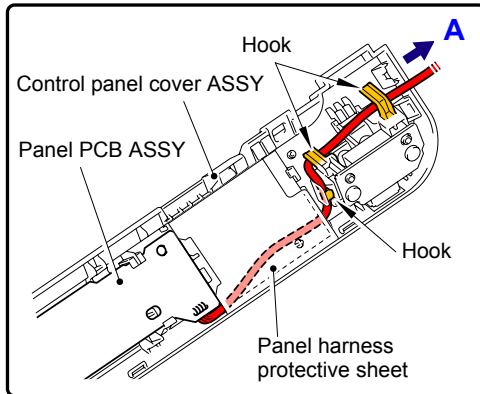

# 13 Control Panel Cover ASSY (HL-3040CN only) (Panel PCB ASSY)

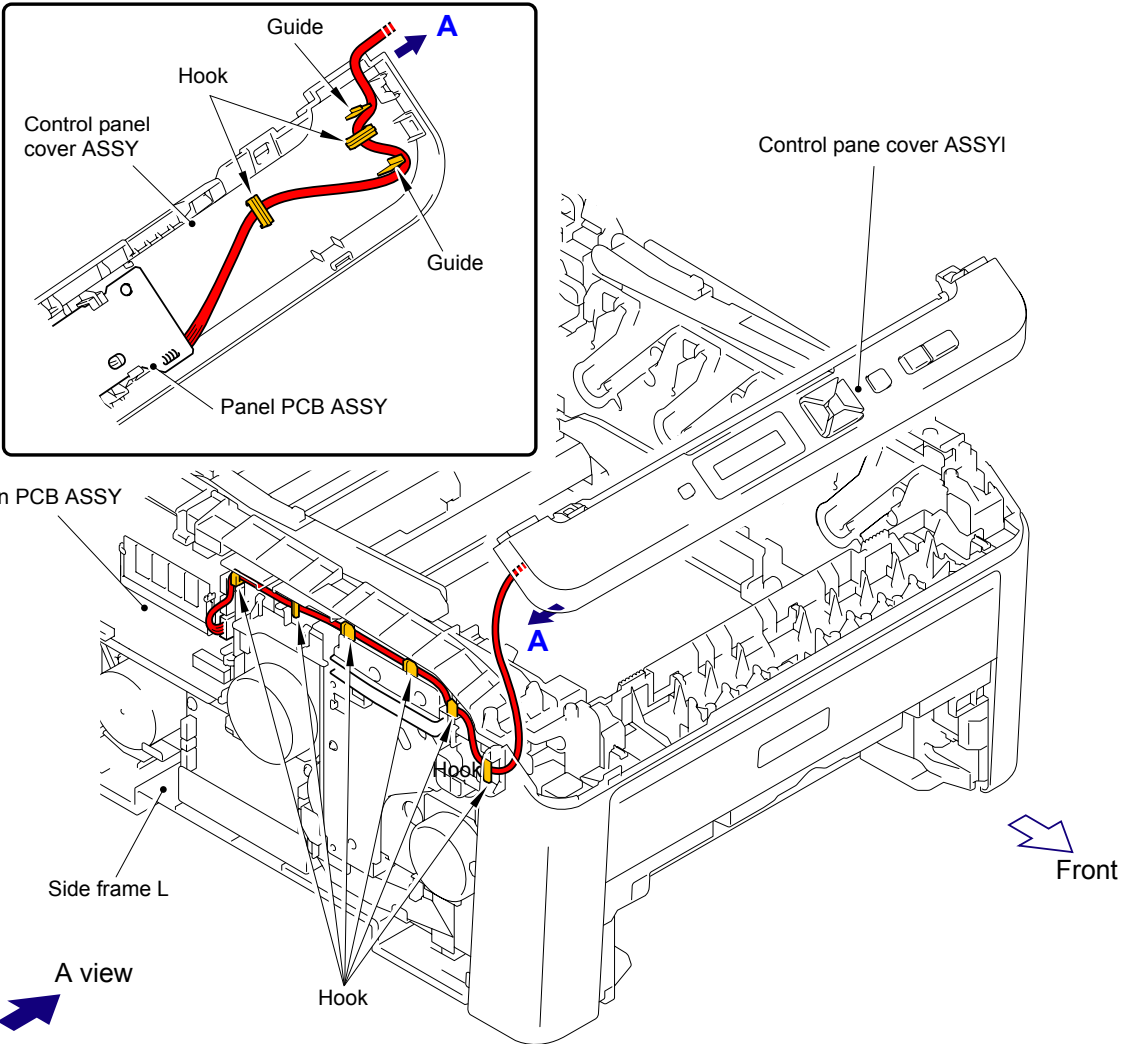
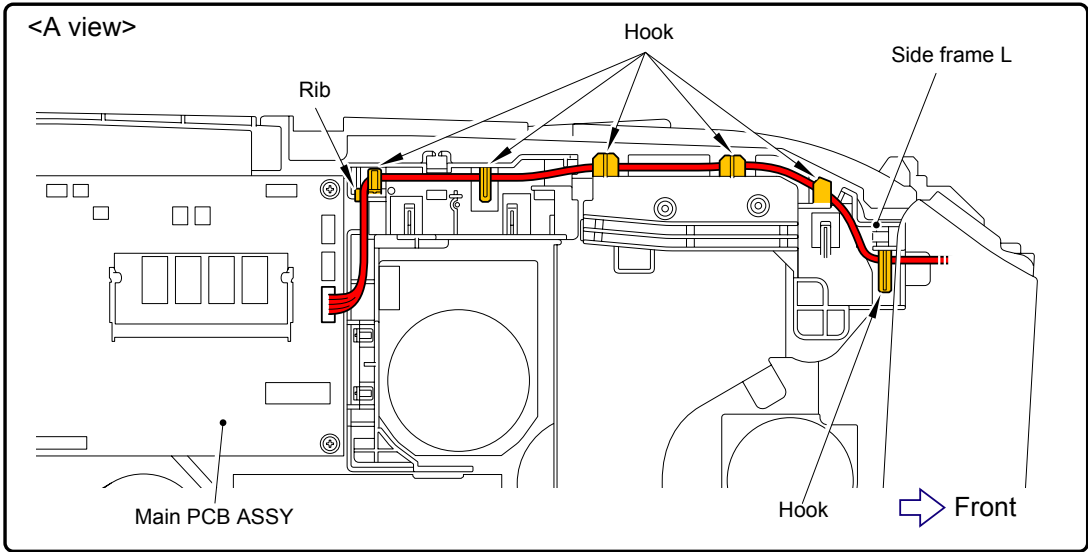

## 14 Eject Rear Sensor PCB ASSY

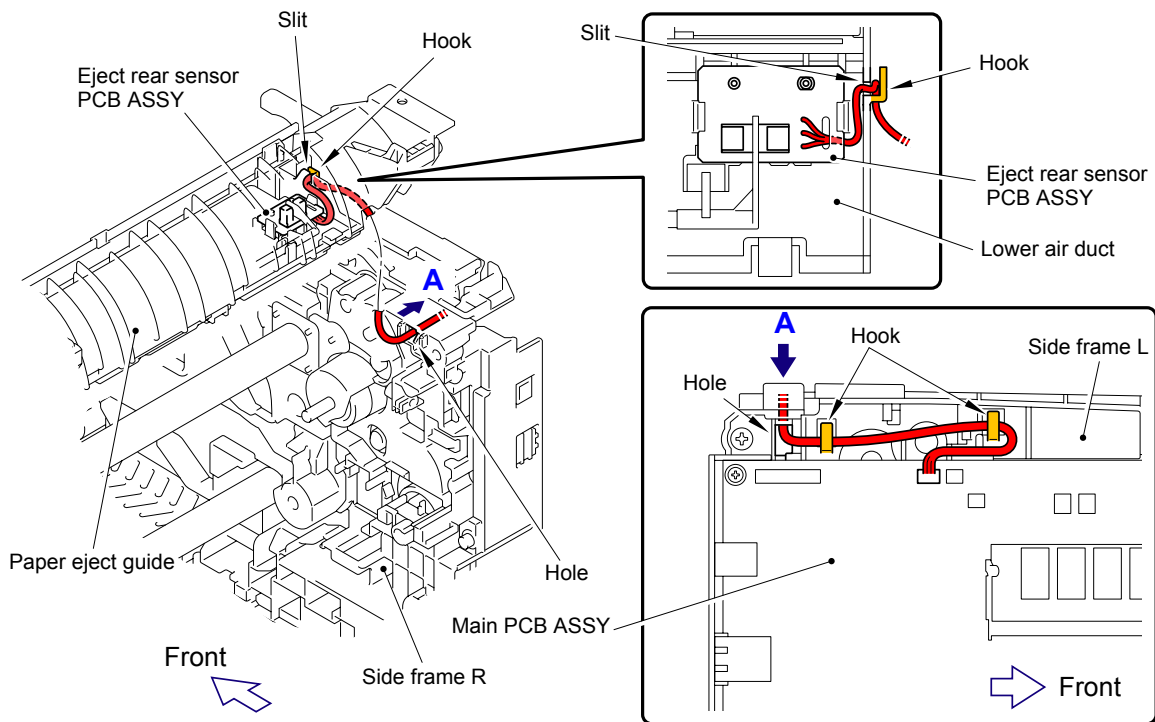

## 15 Eject Front Sensor PCB ASSY

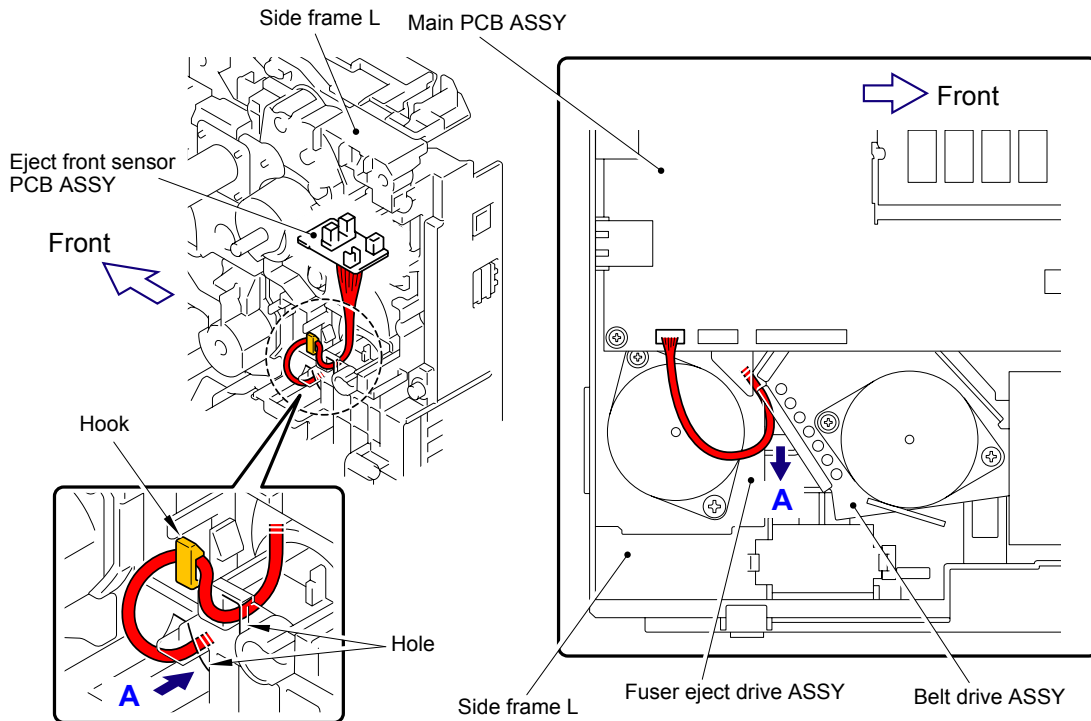

# 16 Waste Toner Sensor

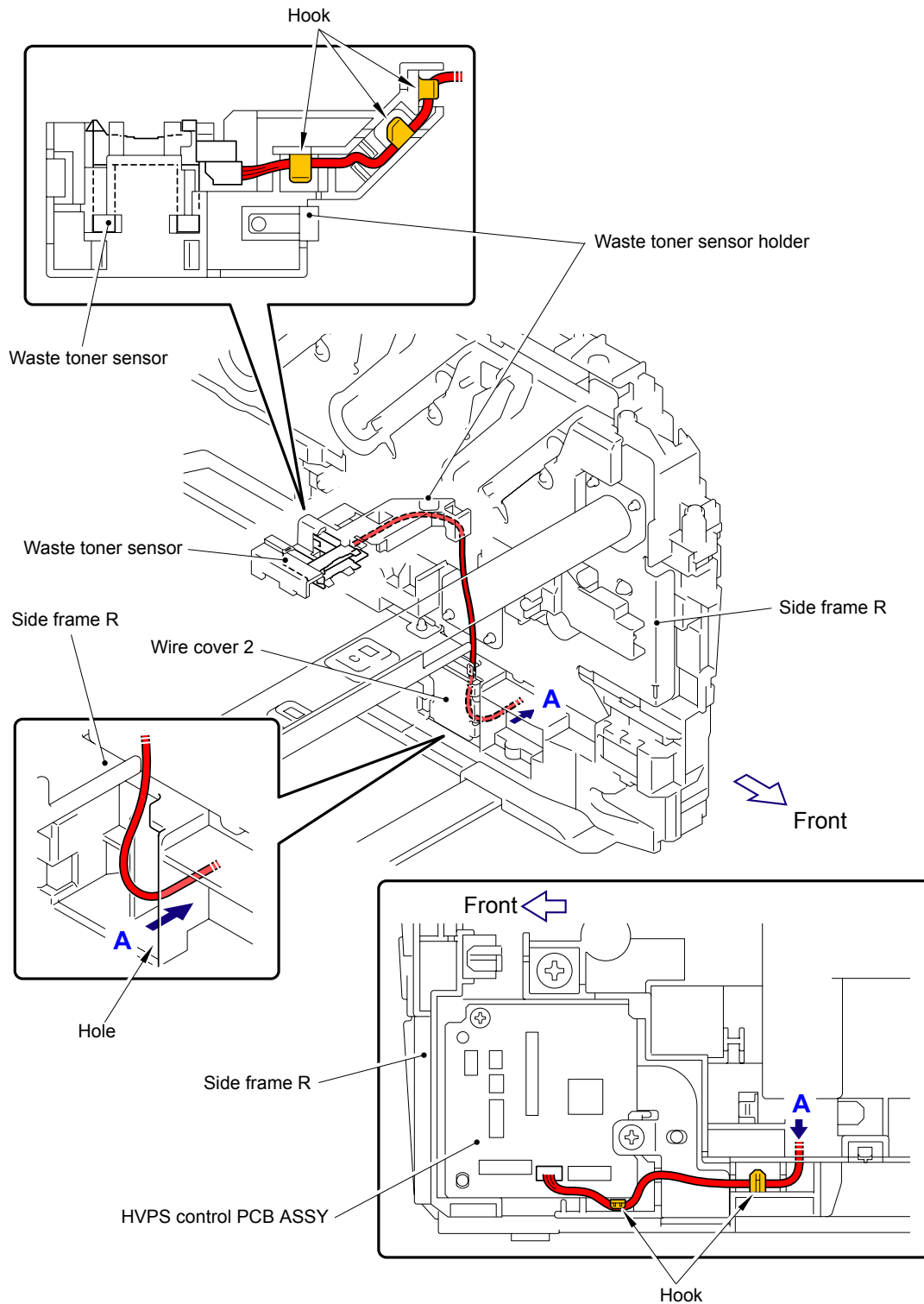

## 17 Main Fan ASSY, LV Fan ASSY

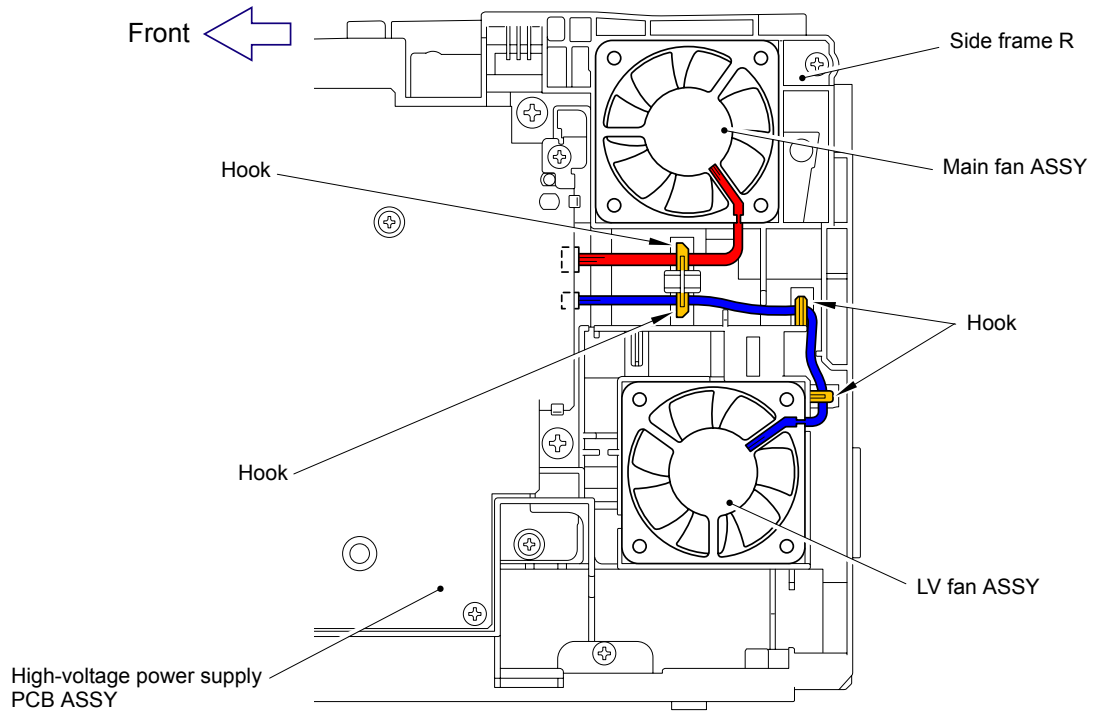

## 18 Develop Release Sensor PCB ASSY, Top Cover Open Switch, Toner LED PCB ASSY

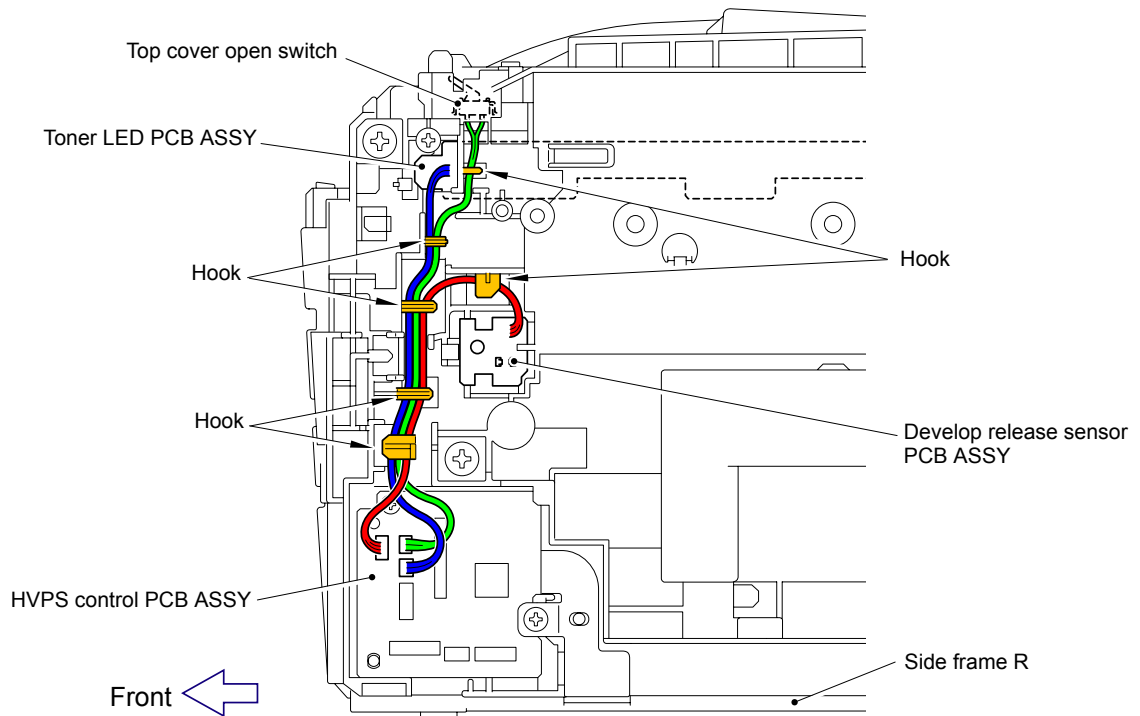



# 19 Registration Sensor Holder ASSY

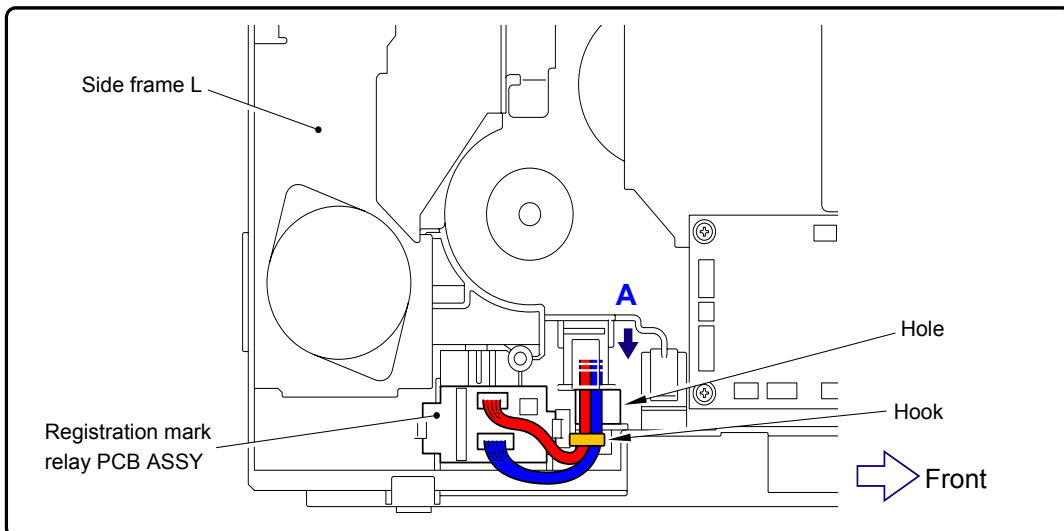
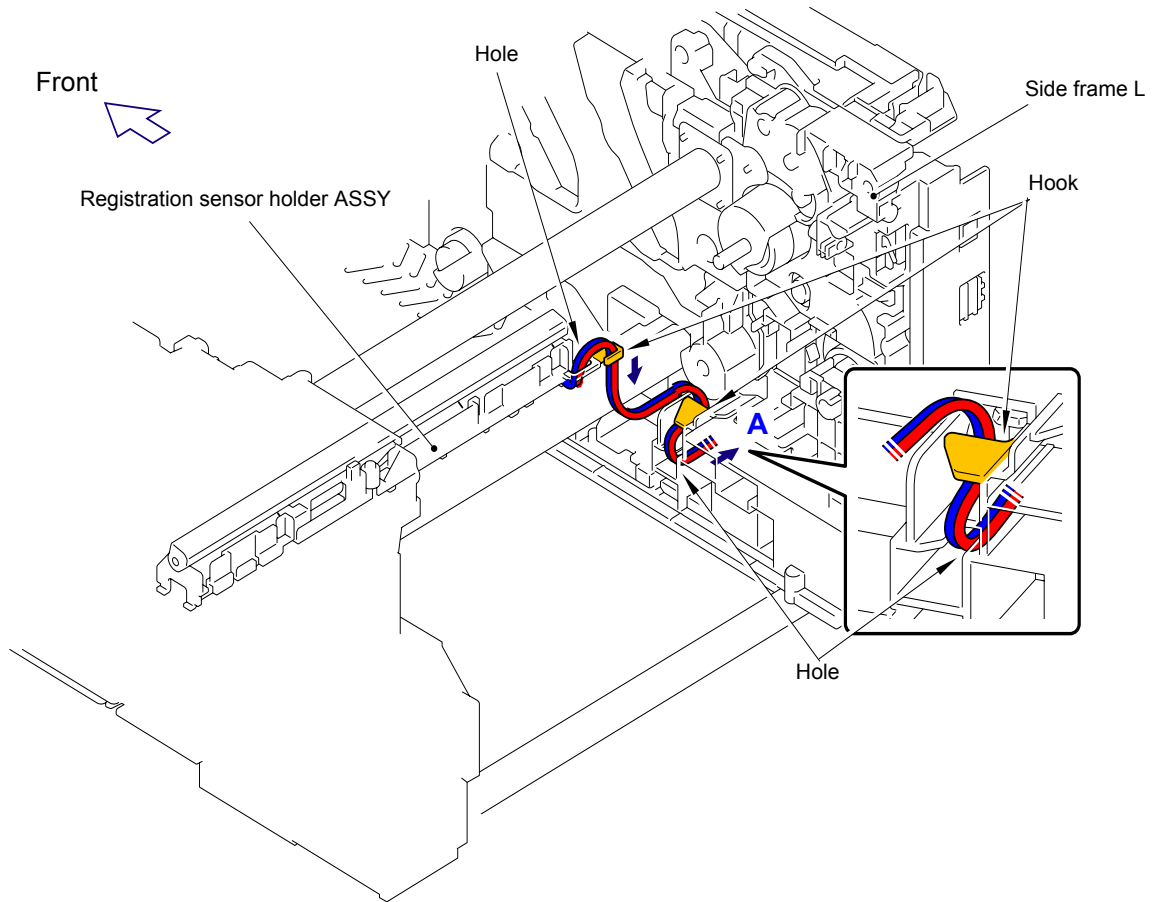

## 20 Low-voltage Power Supply PCB ASSY

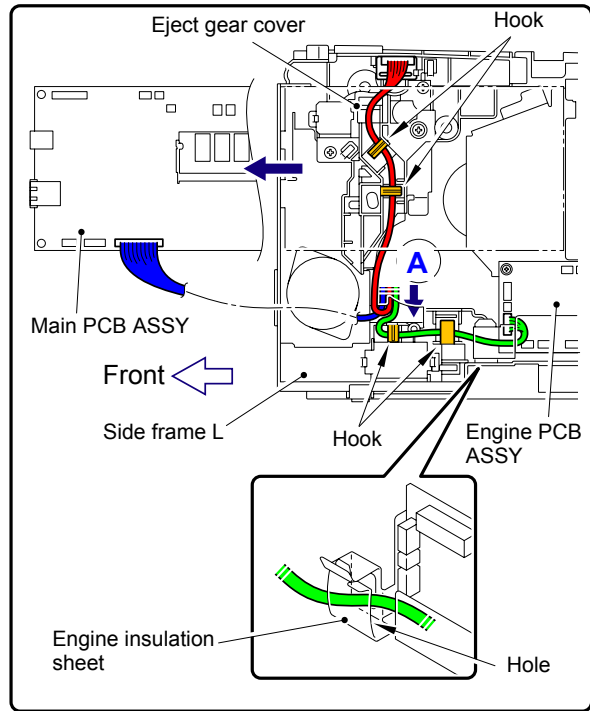
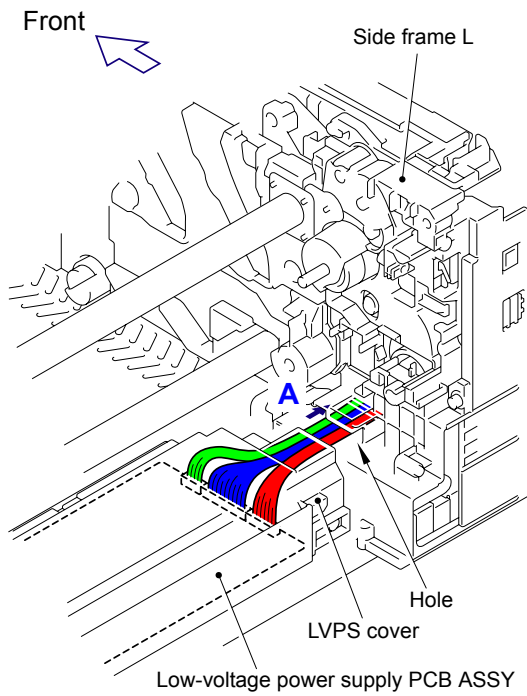

## 21 Back Cover Sensor

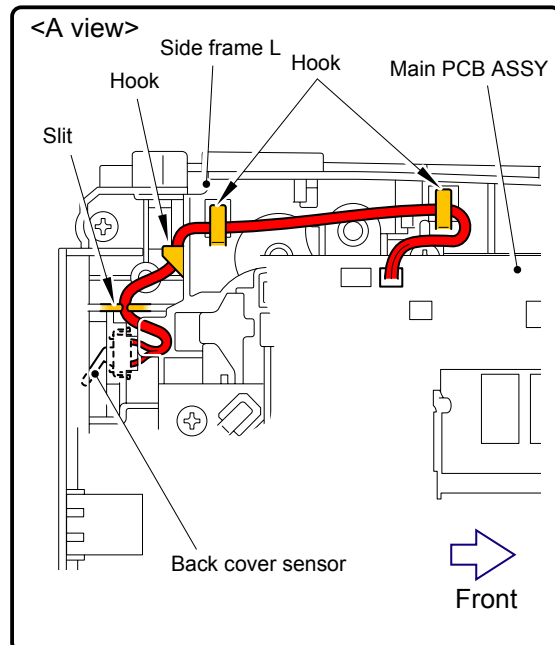
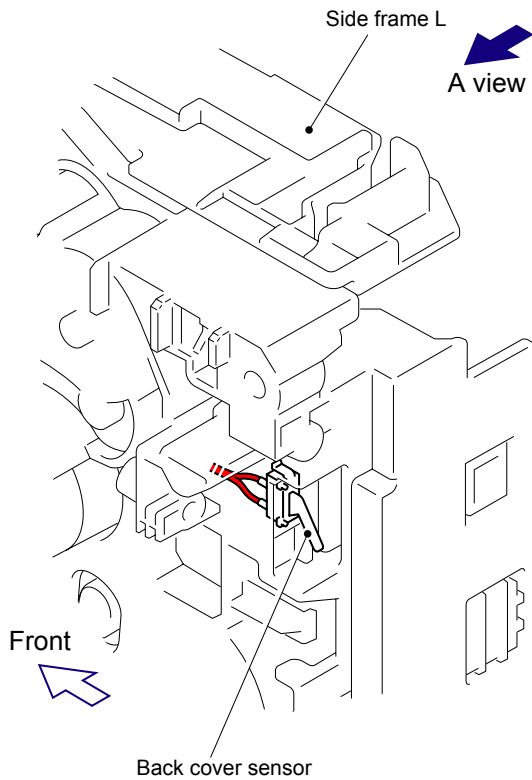

## 22 HVPS Control PCB ASSY

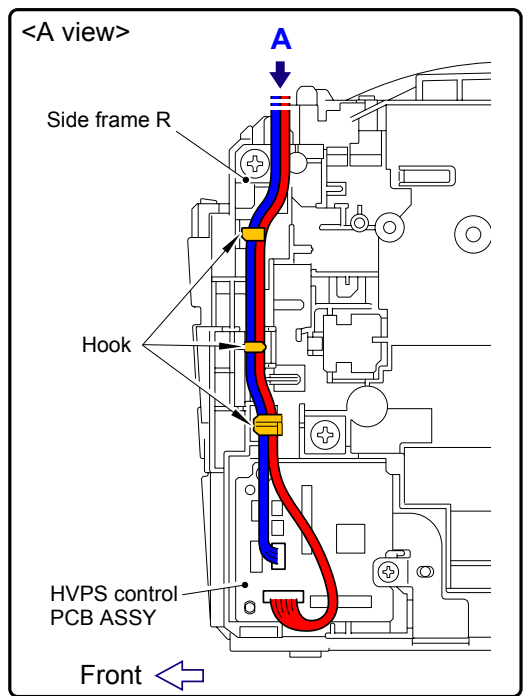
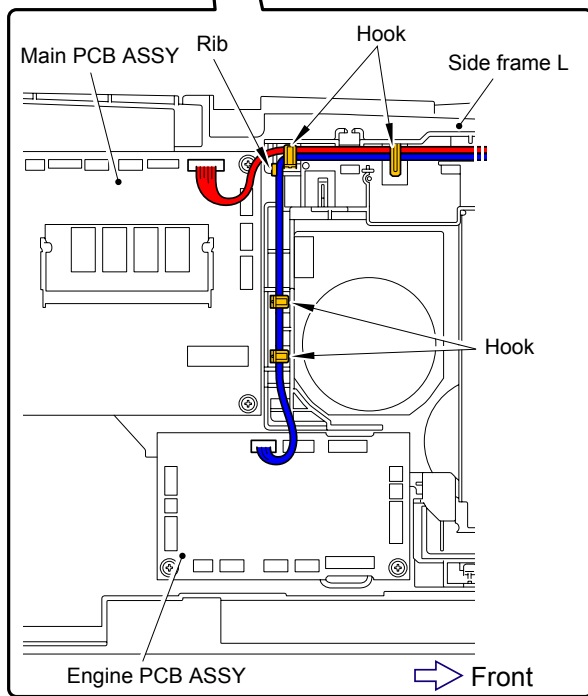
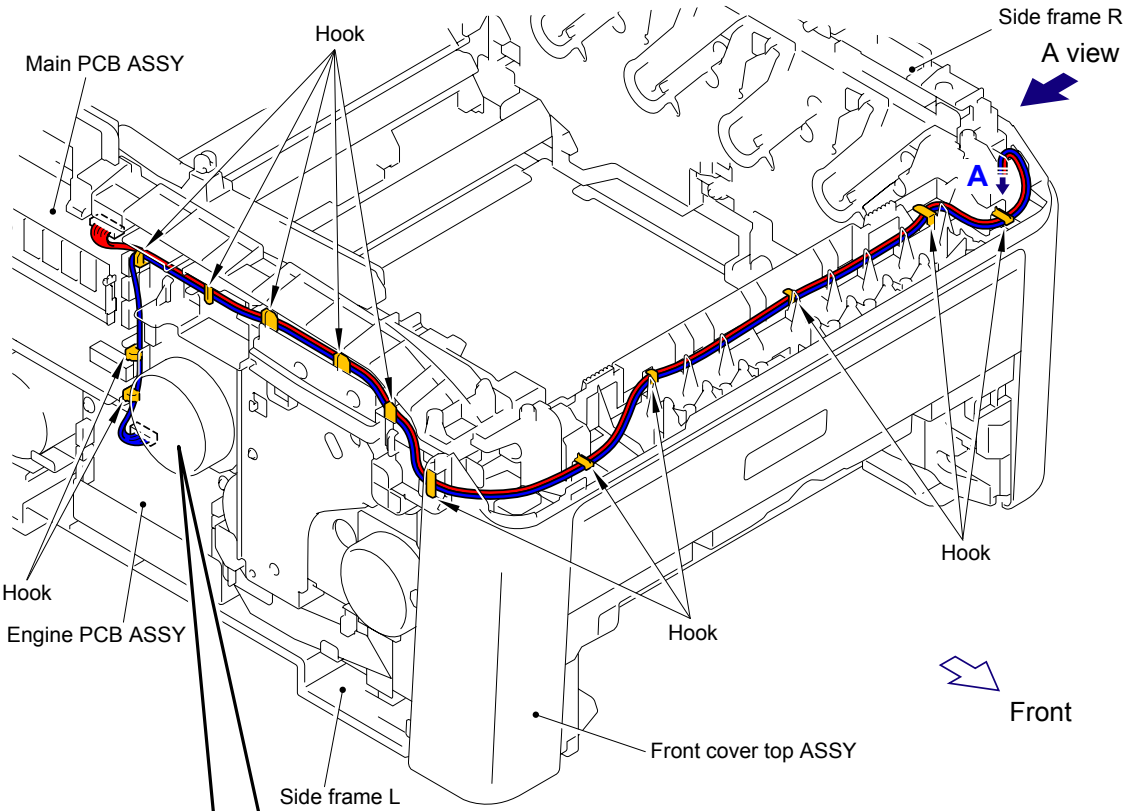

# 7. DISASSEMBLY FLOW

Disassembly/Re-Assembly (second)

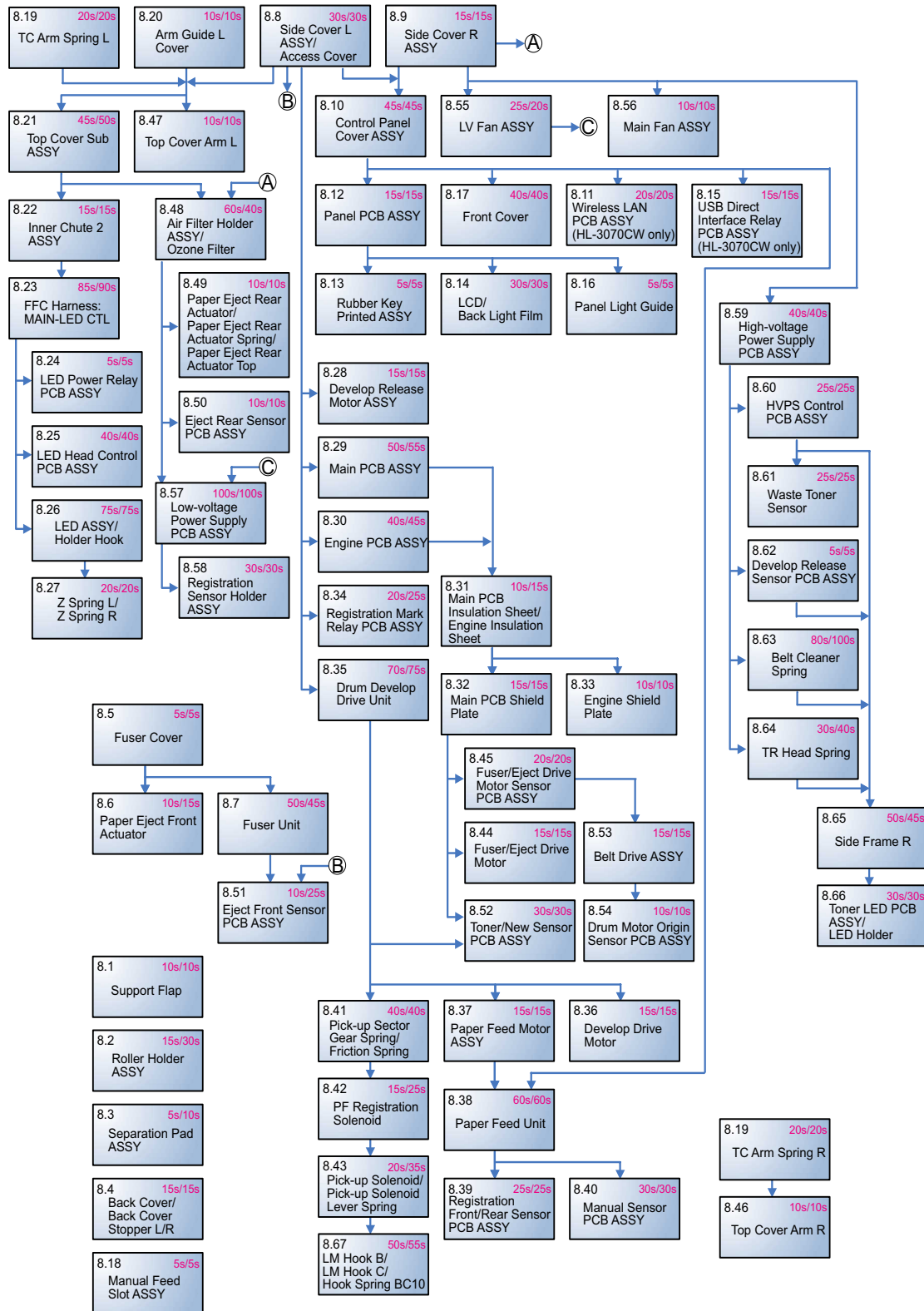

## 8. DISASSEMBLY PROCEDURE

### ■ Preparation

Prior to proceeding with the disassembly procedure,

#### (1) Unplug

- the AC cord,
- the USB cable, if connected,
- the LAN cable, if connected, and
- the USB cable for PictBridge or USB flash memory drive, if connected.

#### (2) Remove

- the Paper tray,
- the Toner cartridge,
- the Drum unit,
- the Belt unit, and
- the Waste toner box.

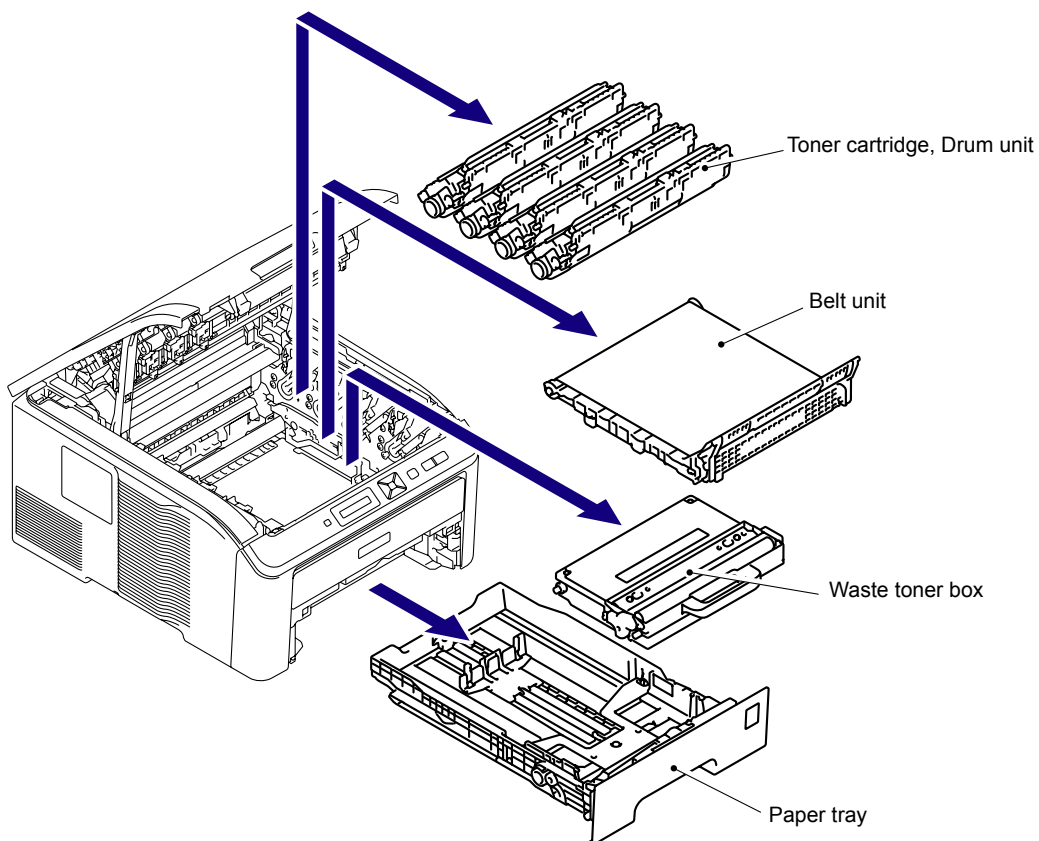

# 8.1 Support Flap

(1) Release the two Bosses to remove the Support flap from the Top cover sub ASSY.

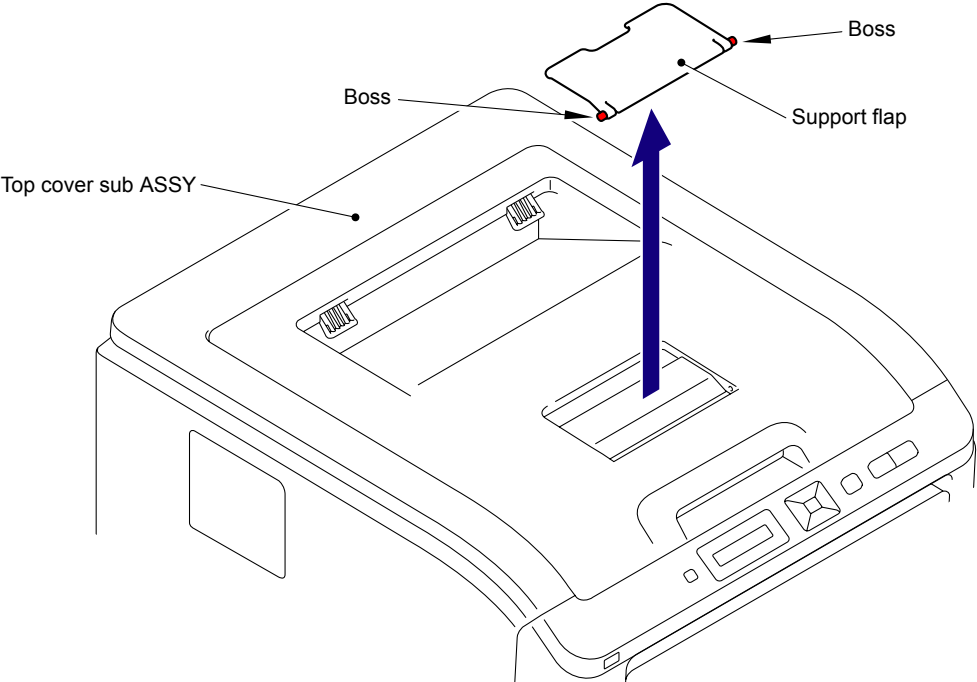

Fig. 5-1

## 8.2 Roller Holder ASSY

- (1) Push the Lift arm to the back and remove "B" of the Roller holder ASSY from "A" of the Lift arm, and the Roller holder ASSY rotates in the direction of the arrow 1b.

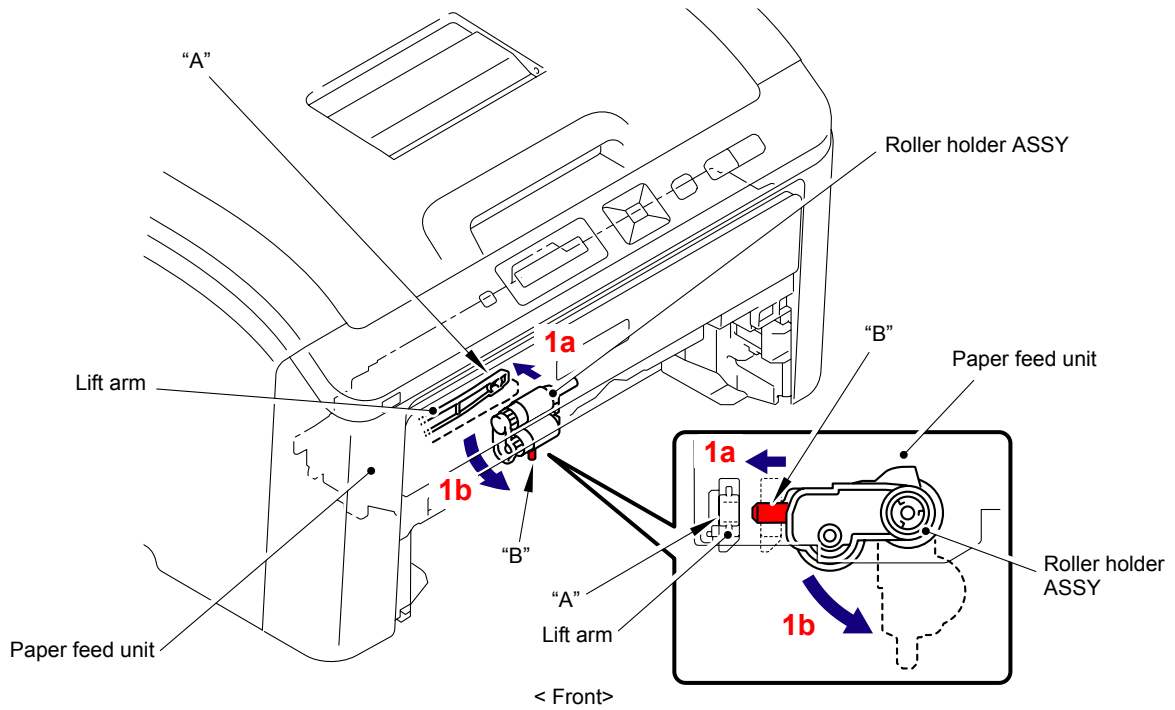

Fig. 5-2

- (2) Slide the Roller holder ASSY in the direction of the arrow 2 and remove it from "C" of the Paper feed unit.
- (3) Slide the Roller holder ASSY in the direction of the arrows 3a and 3b in this order and remove it from the Paper feed unit.

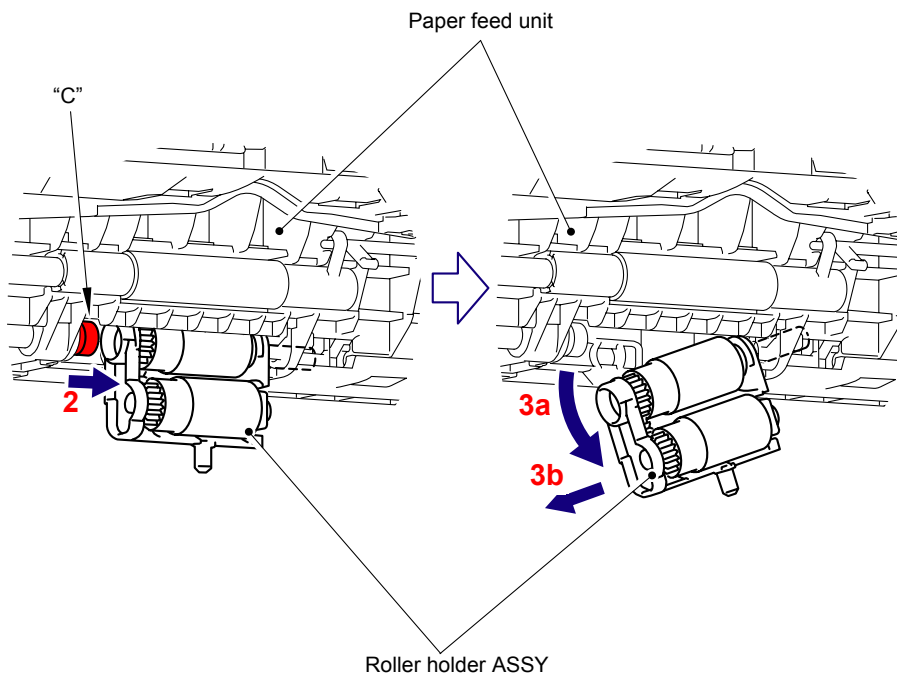
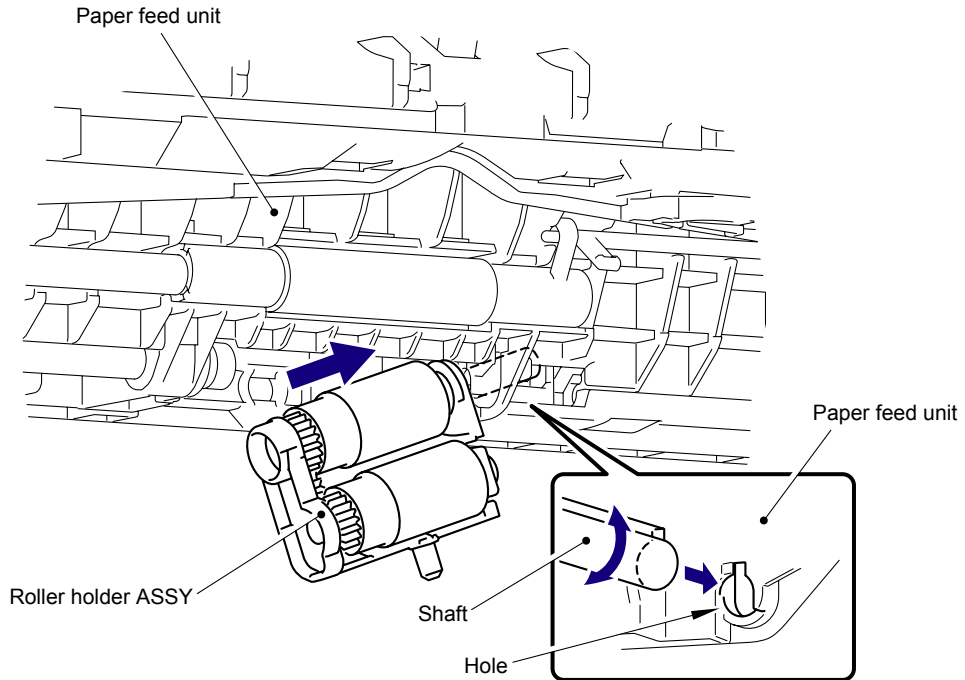

Fig. 5-3

**Assembling Note:**

When assembling the Roller holder ASSY onto the Paper feed unit, make sure to align the Shaft of the Roller holder ASSY with the Hole of the Paper feed unit, and then insert it into the Hole.



**Fig. 5-4**



## 8.3 Separation Pad ASSY

- (1) Release the two Hooks of the Separation pad ASSY from the Paper tray.
- (2) Release the two Pins to remove the Separation pad ASSY from the Paper tray.

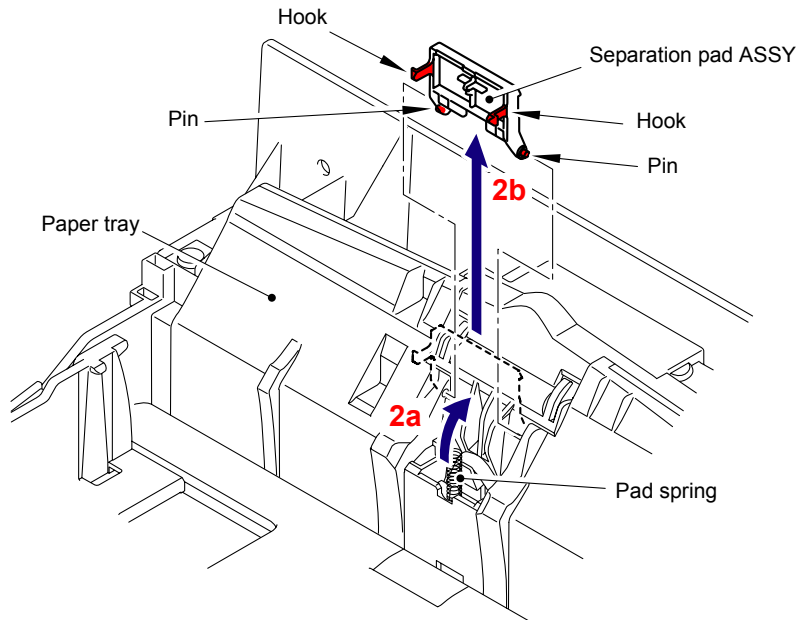

Fig. 5-5

- (3) Remove the Pad spring from the Paper tray.

**Note:**

Be careful not to loose the Pad spring.

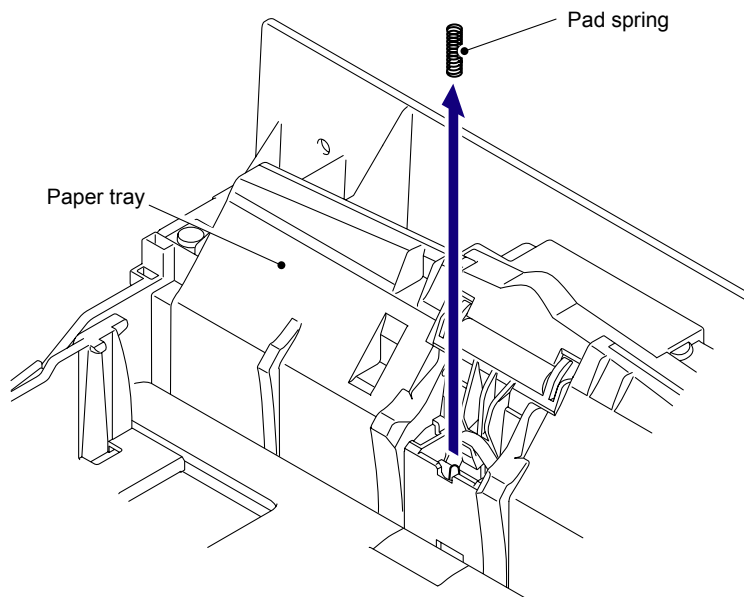
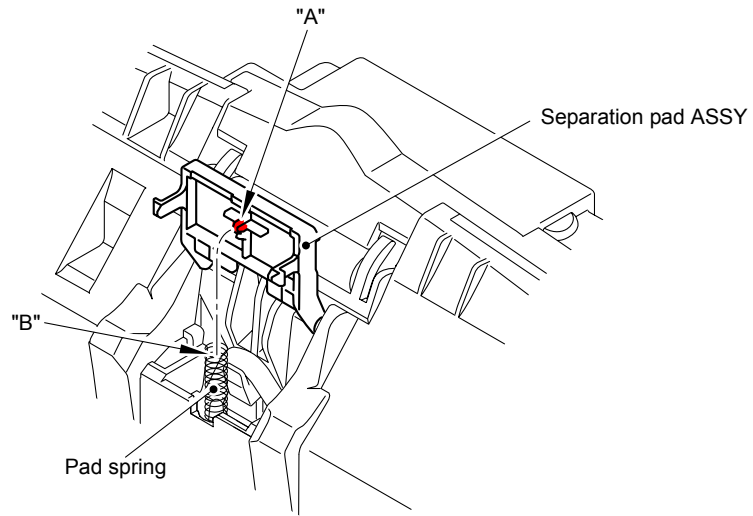

Fig. 5-6

**Assembling Note:**

Make sure to assemble the Separation pad ASSY in a way that the "A" of the Separation pad ASSY fits into the "B" of the Pad spring.



**Fig. 5-7**

# 8.4 Back Cover/Back Cover Stopper L/R

(1) Open the Back cover.

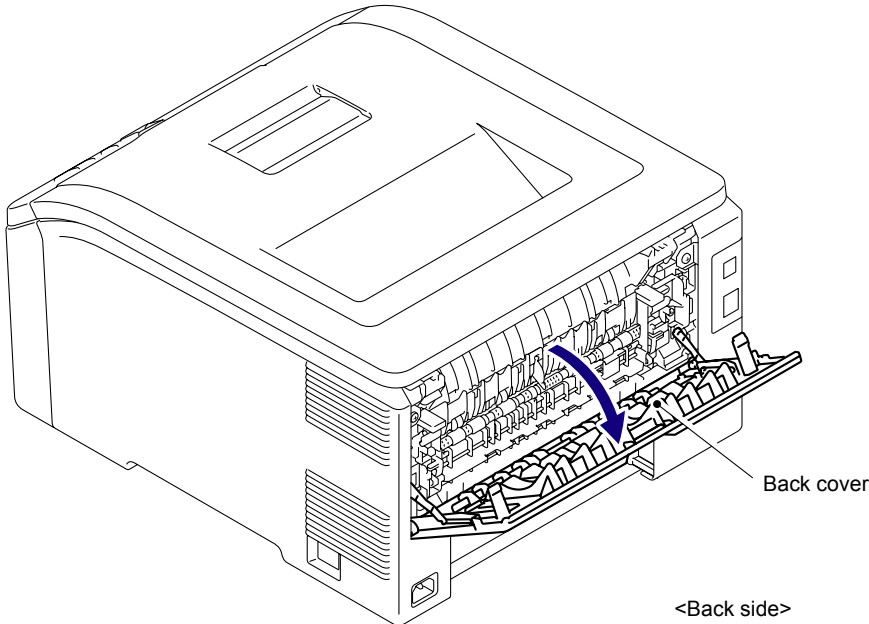

Fig. 5-8

(2) Remove the Hook and then remove Back cover stopper L and R from the Main body.

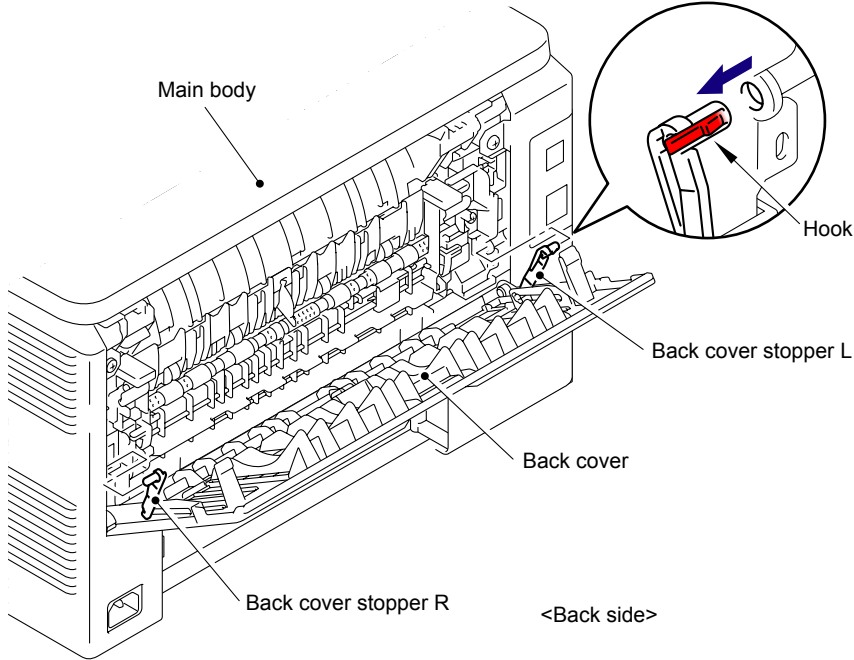

Fig. 5-9

(3) Remove the Bush of the Back cover from the Shaft at the right side of the Main body.

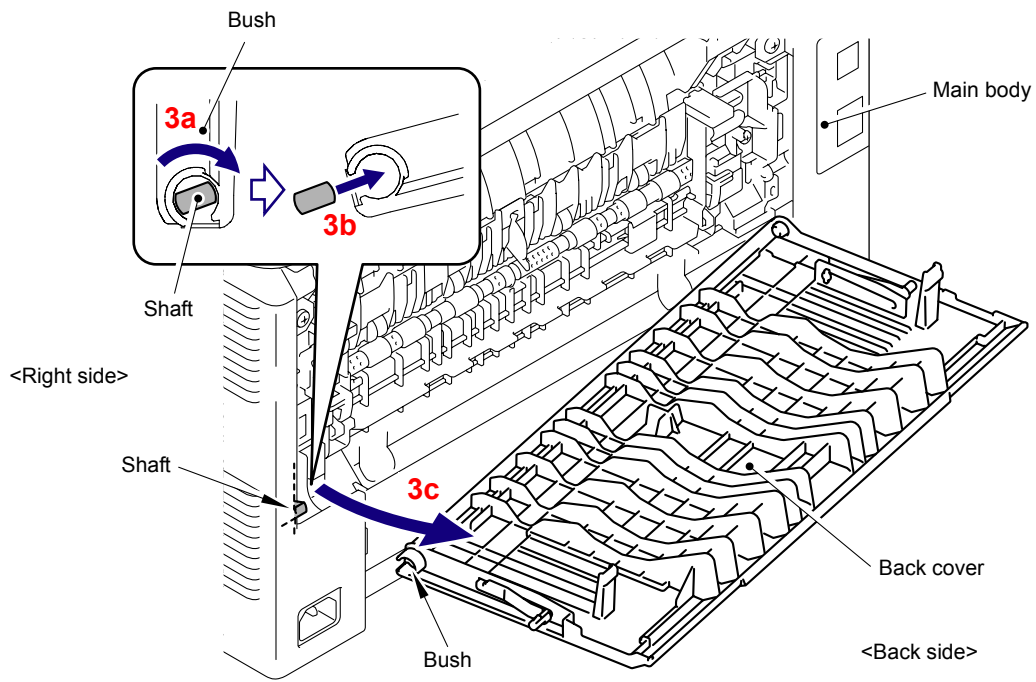

Fig. 5-10

(4) Remove the Back cover from the Shaft at the left side of the Main body.

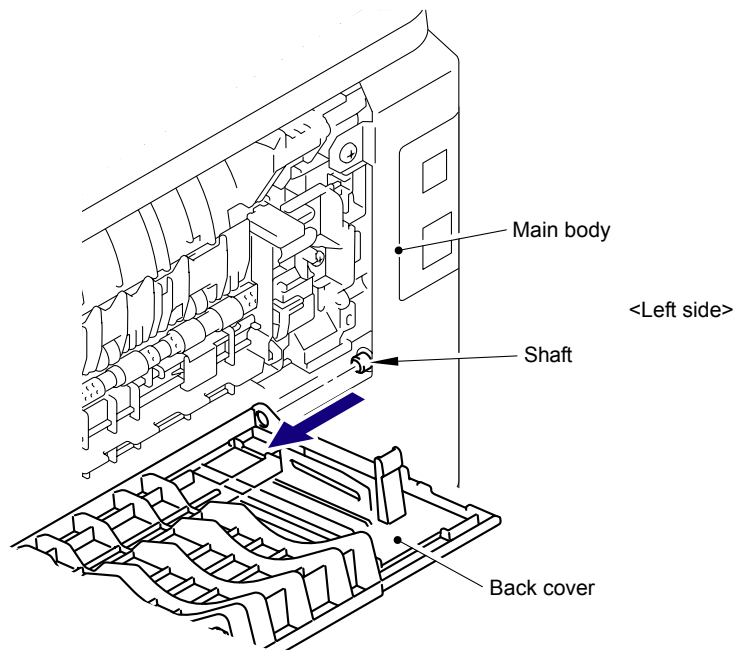

Fig. 5-11

(5) Remove the Back cover stopper L and R from the Back cover.

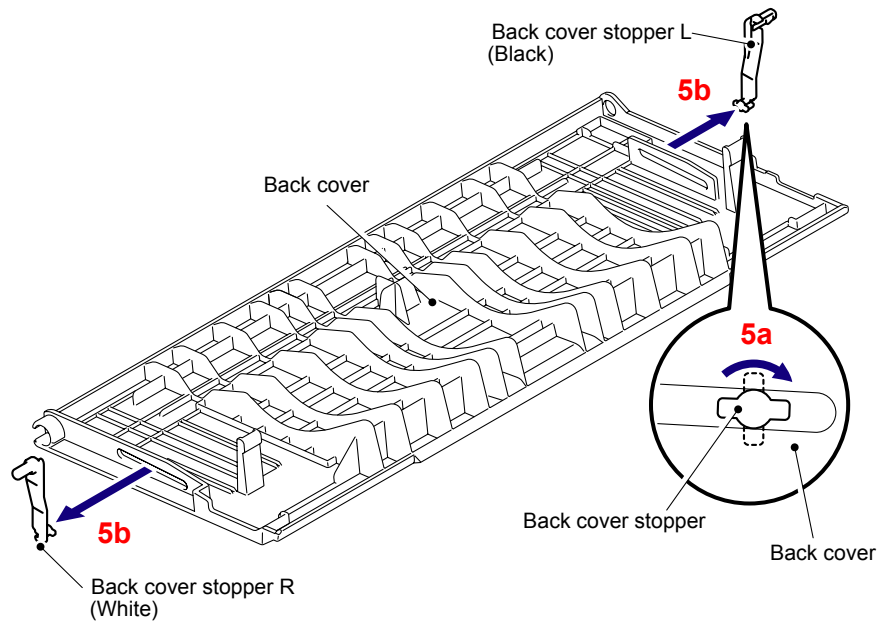

Fig. 5-12

## 8.5 Fuser Cover

- (1) Release of the Fuser cover lock lever L and R and open the Fuser cover.

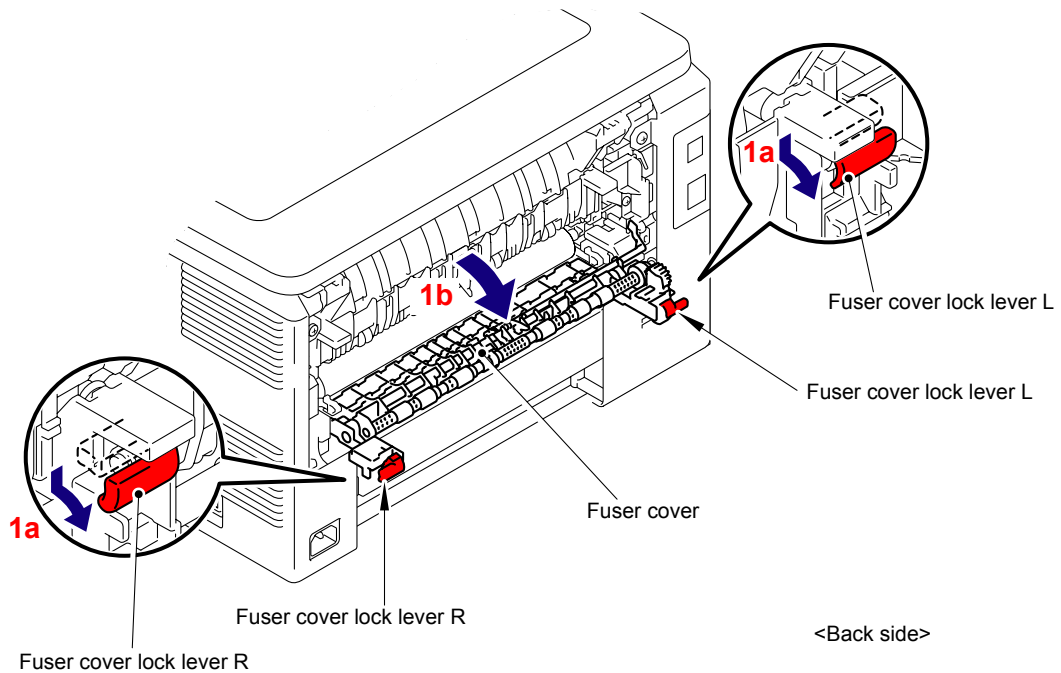

Fig. 5-13

- (2) Remove the left Shaft of the Fuser cover from the Notch on the Bush of the Side frame L.
- (3) Remove the right Shaft of the Fuser cover from the Bush of the LVPS cover.

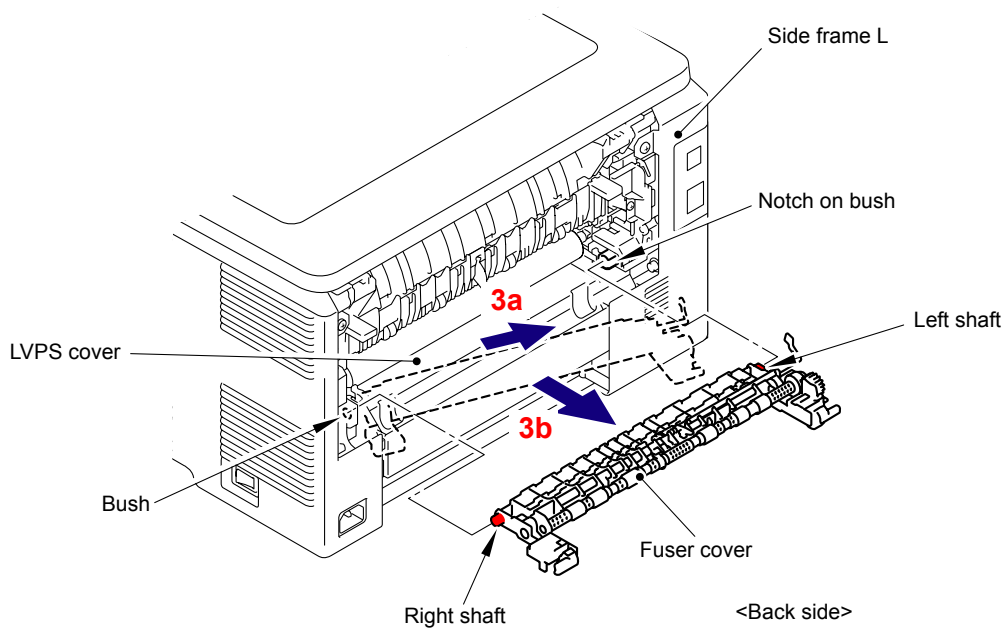

Fig. 5-14

## 8.6 Paper Eject Front Actuator

- (1) Release the Hook and slide the Paper eject front actuator in the direction of arrows 1a and 1b in this order.

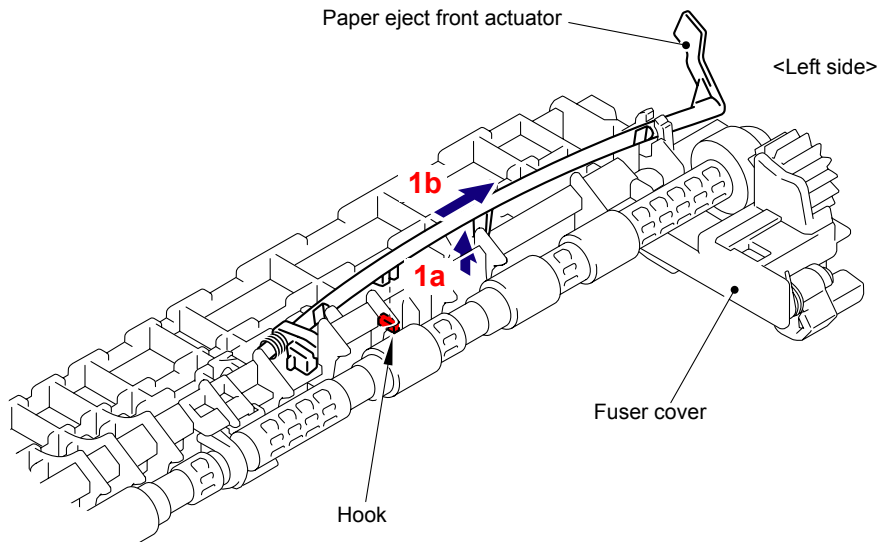

Fig. 5-15

- (2) Align the "A" and "B" of the Paper eject front actuator with the "C" and "D" of the Fuser cover respectively, and remove the Paper eject front actuator.

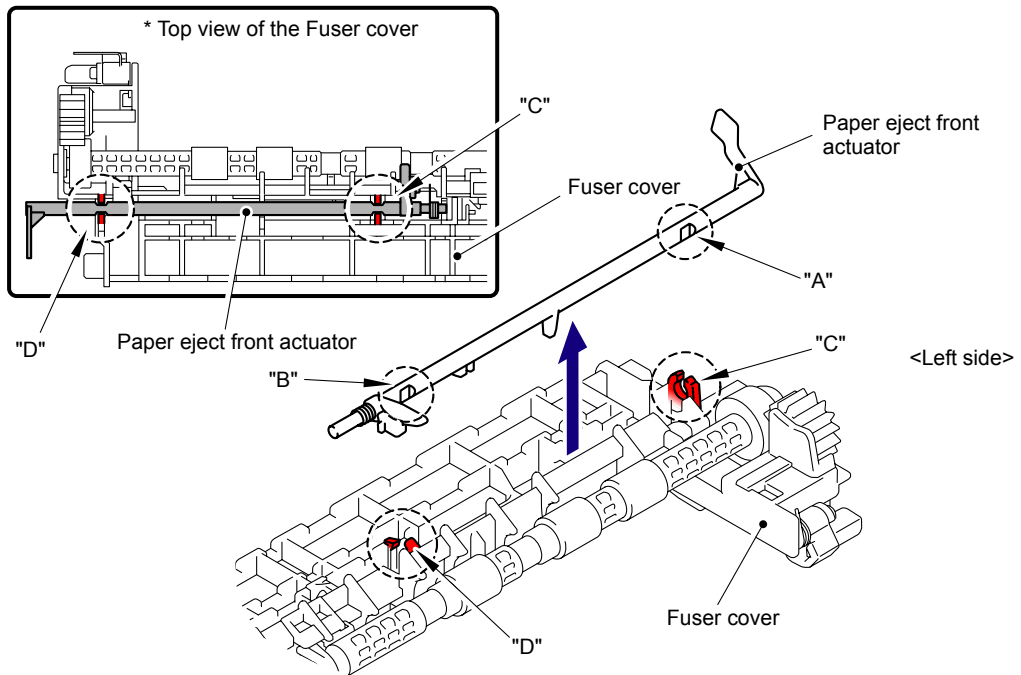

Fig. 5-16

(3) Remove the Paper eject front actuator spring from the Paper eject front actuator.

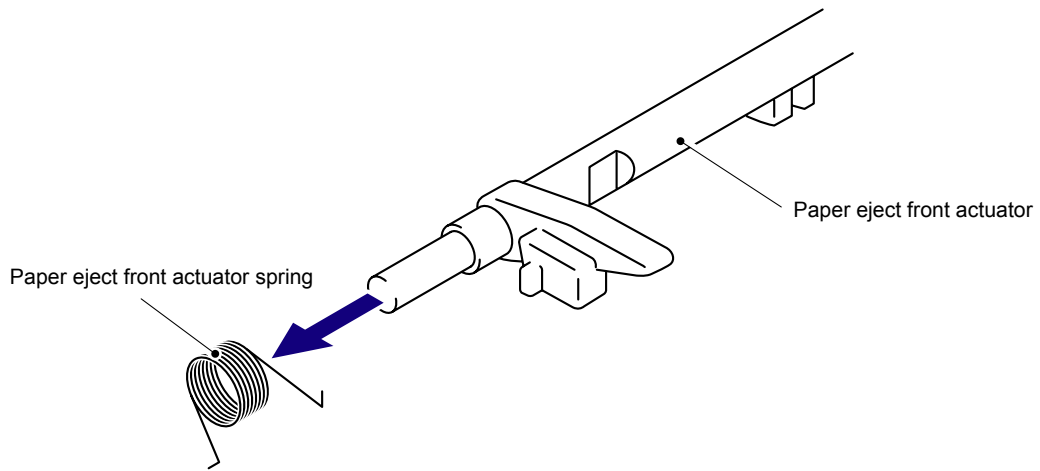

Fig. 5-17

**Assembling Note:**

- When assembling the Paper eject front actuator, assemble the Paper eject front actuator spring as shown in the figure below.
- Check that the Paper eject front actuator is moved smoothly.

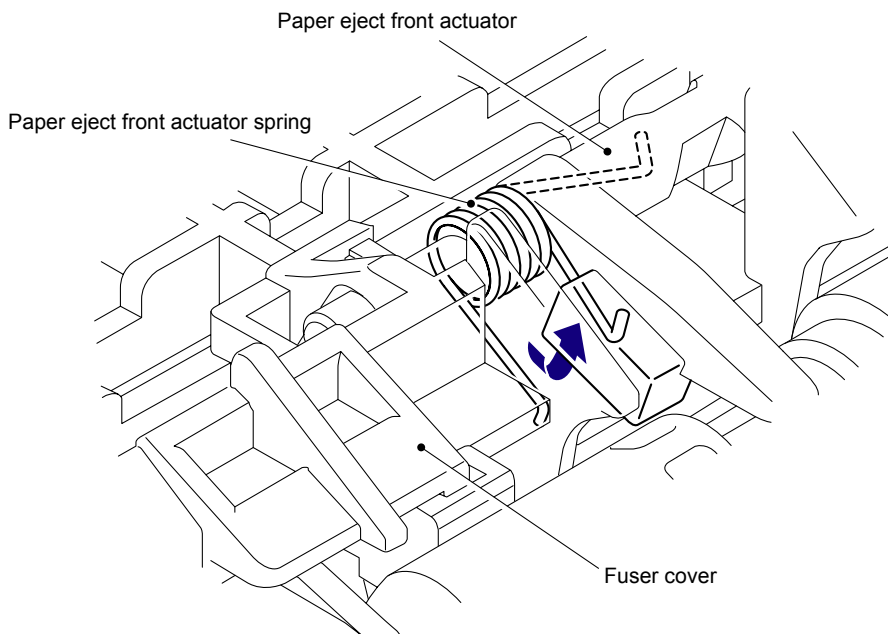

Fig. 5-18



# 8.7 Fuser Unit

- (1) Remove the Taptite bind B M3x12 screw, and then remove the Fuser cover L from the Fuser unit.

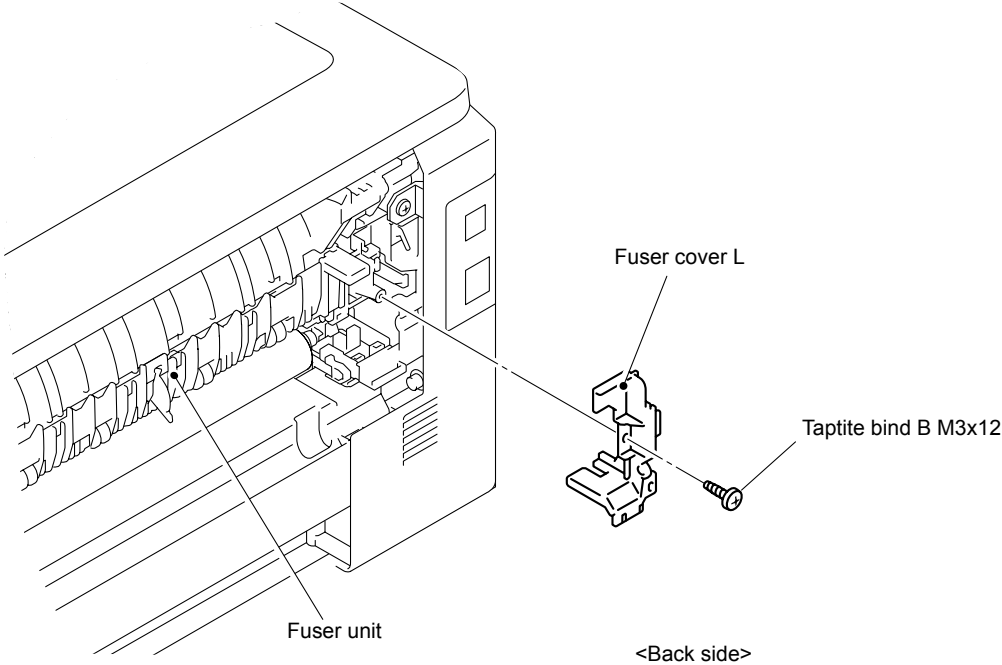

Fig. 5-19

- (2) Remove the Taptite bind B M3x12 screw, and then remove the Fuser cover R from the Fuser unit.

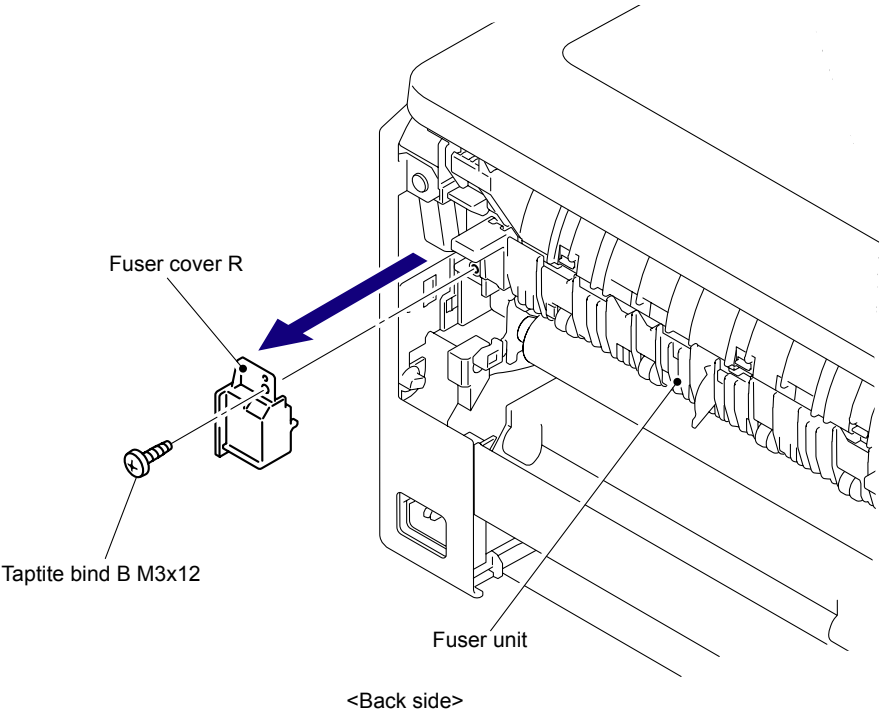
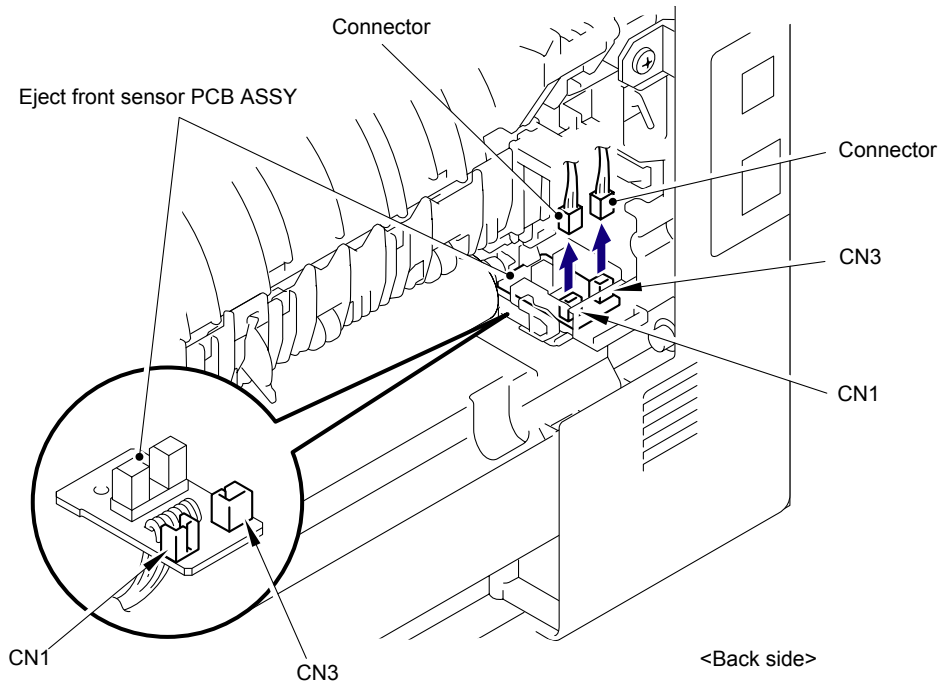

Fig. 5-20

(3) Disconnect the two Connectors (CN1, CN3) from the Eject front sensor PCB ASSY.



**Fig. 5-21**

(4) Disconnect the two Electrode terminals from the Fuser unit.

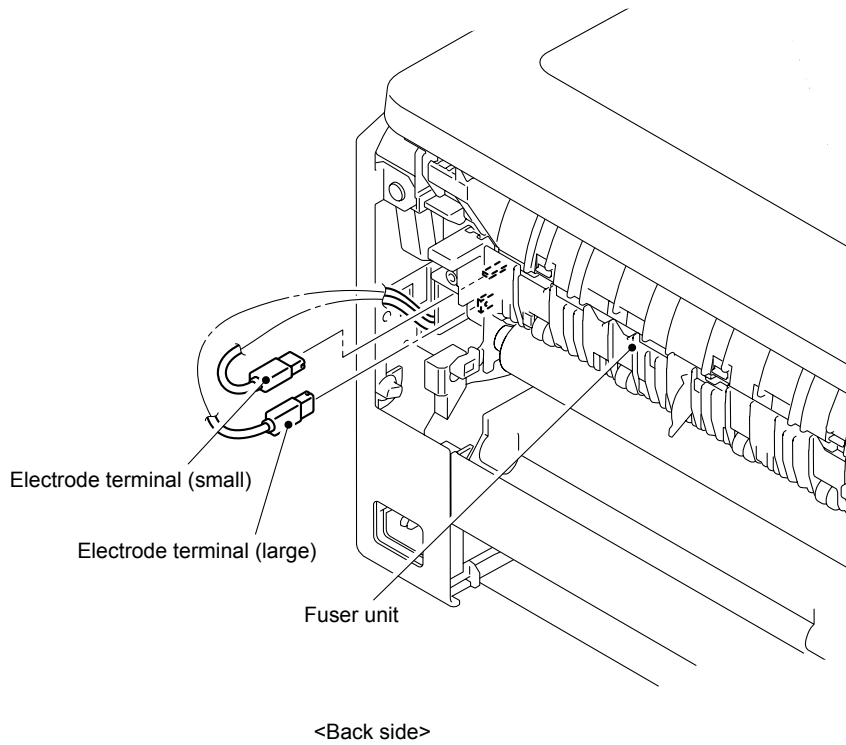

**Fig. 5-22**

- (5) Remove the two Taptite pan B M4x14 screws, and then remove the Fuser unit from the Main body as holding the "A."

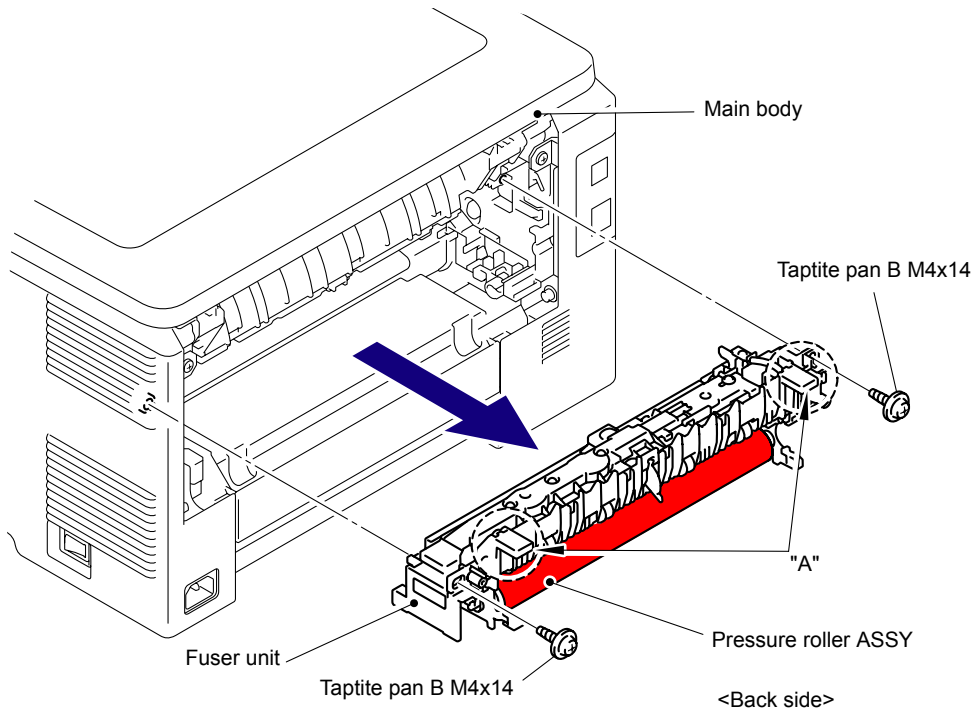

Fig. 5-23

**Note:**

- Do not apply a physical impact or vibration to the Fuser unit.
- Do not touch the roller and electrodes as shown in the figure below to prevent breakage of the Fuser unit.

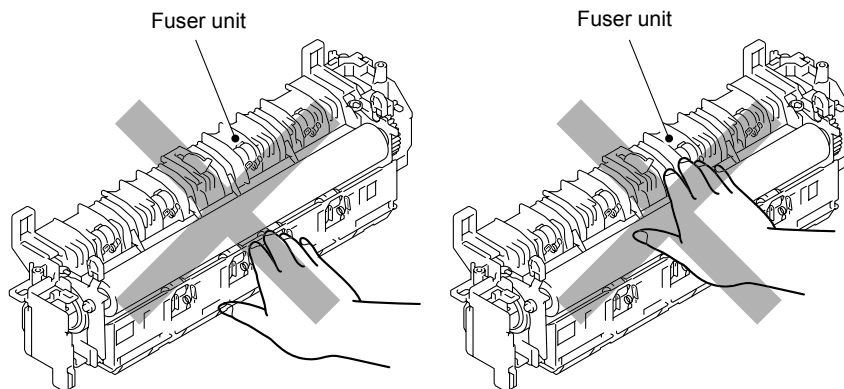
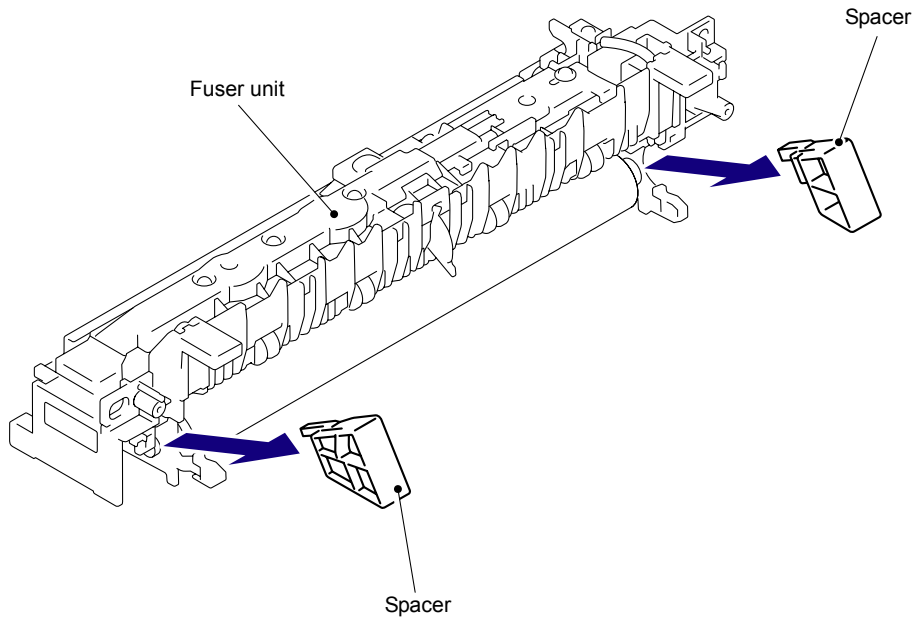

Fig. 5-24

**Assembling Note:**

The Fuser unit for replacement is transported while the pressure roller is held lightly to prevent deformation of the pressure roller. When assembling the Fuser unit, make sure to assemble the Fuser unit to the product first, and then remove the Spacer in the direction of the arrow from the Fuser unit.



**Fig. 5-25**

# 8.8 Side Cover L ASSY/Access Cover

(1) Open the Top cover unit.

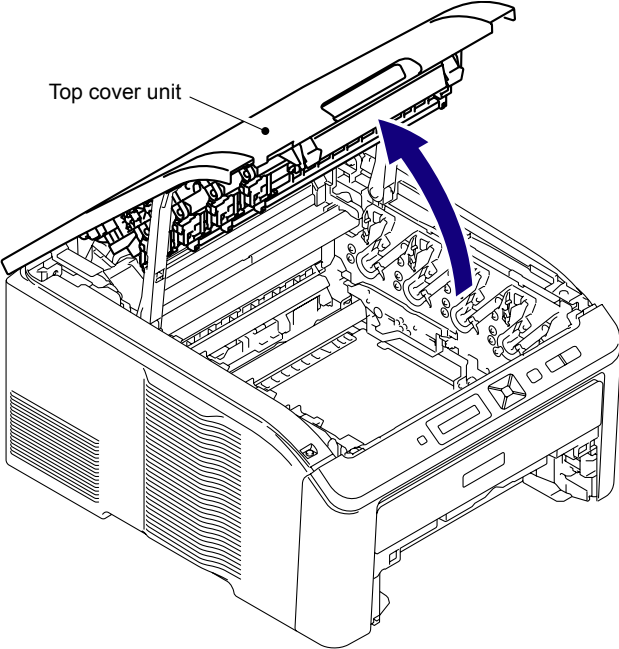
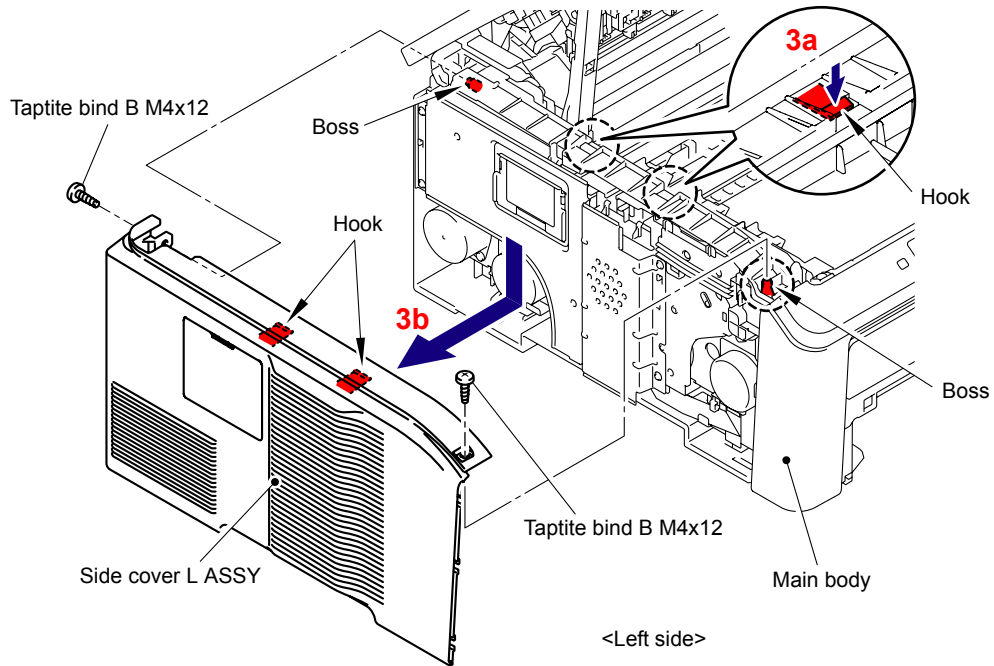

Fig. 5-26

- (2) Remove the two Taptite bind B M4x12 screws from the Side cover L ASSY.
- (3) Release the two Hooks and two Bosses on the upper side and five Hooks on the bottom, and then remove the Side cover L ASSY from the Main body.



\* Inside of Side cover L ASSY

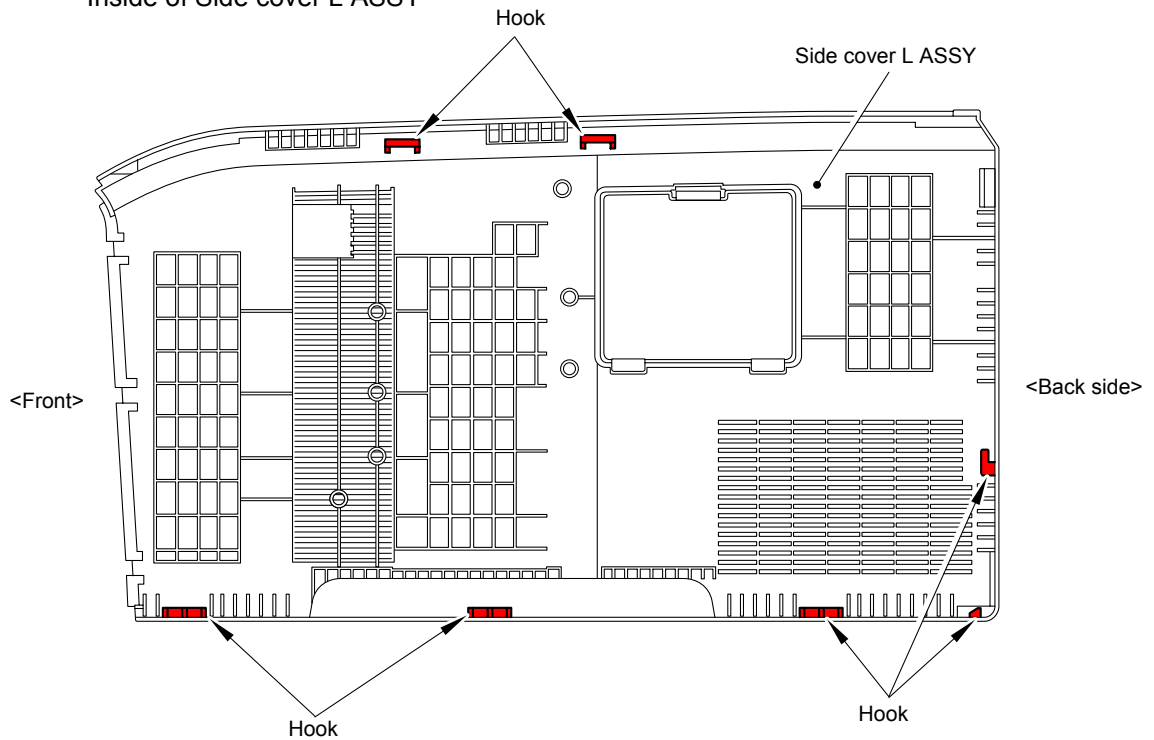
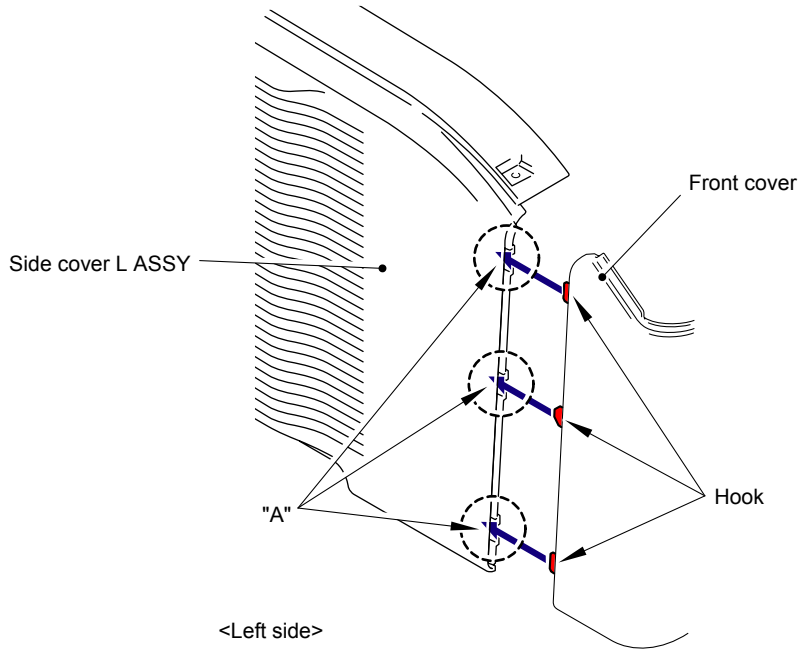

Fig. 5-27

**Assembling Note:**

When assembling the Side cover L ASSY onto the Main body, make sure to push the three Hooks of the Front cover into the three "A" of the Side cover L ASSY.



**Fig. 5-28**

- (4) Remove the Access cover from the Side cover L ASSY.

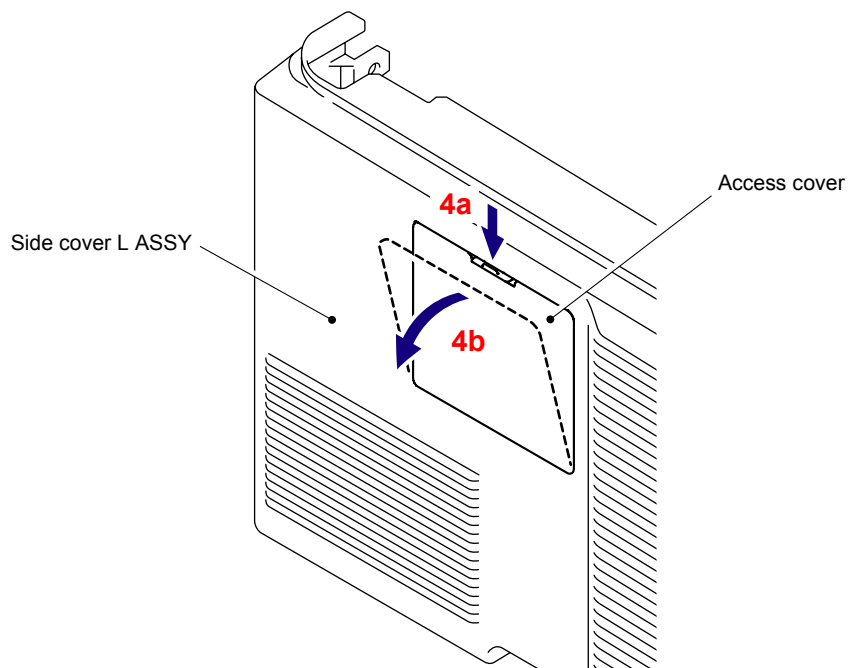

**Fig. 5-29**

## 8.9 Side Cover R ASSY

- (1) Remove the two Taptite bind B M4x12 screws from the Side cover R ASSY.
- (2) Release the two Hooks and two Bosses on the upper side and five Hooks on the bottom, and then remove the Side cover R ASSY from the Main body.

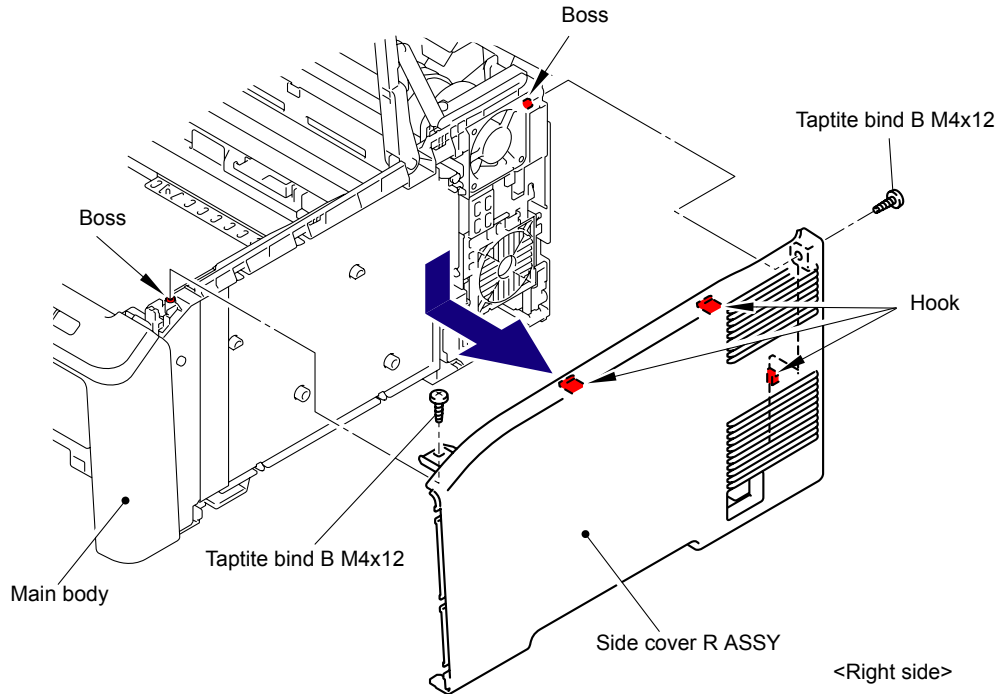

\* Inside of Side cover R ASSY

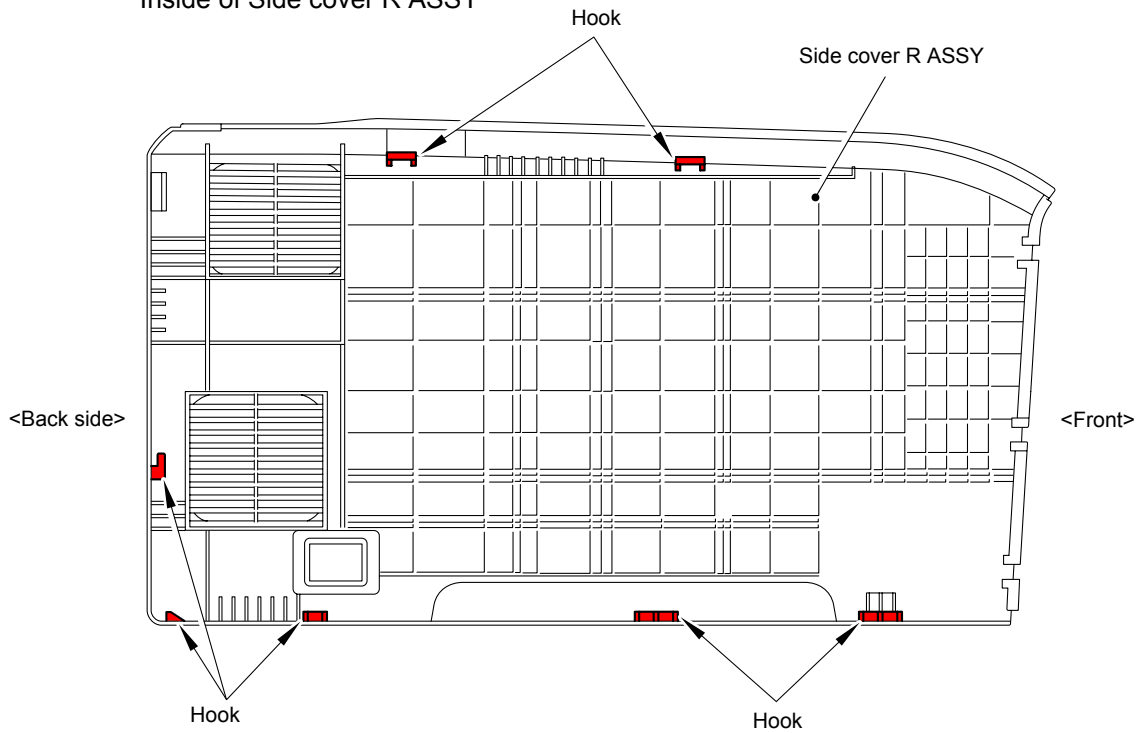
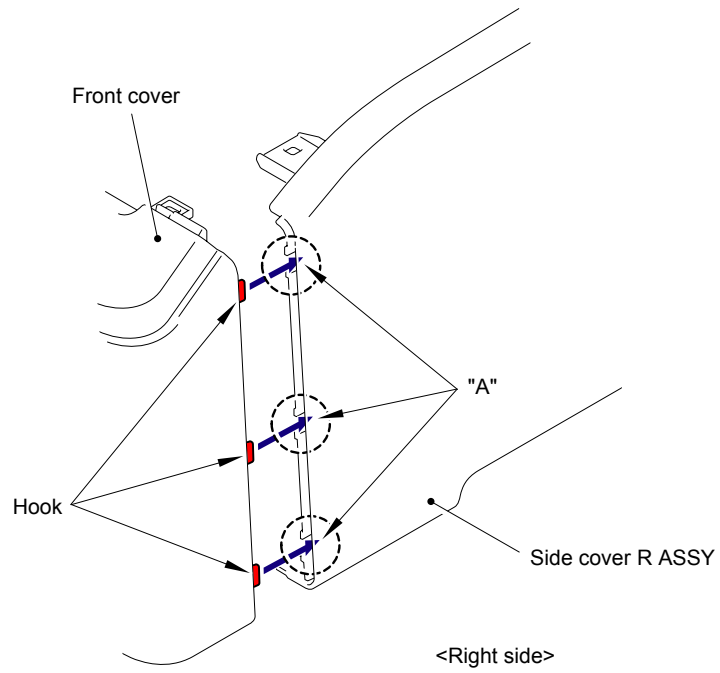

Fig. 5-30



**Assembling Note:**

When assembling the Side cover R ASSY onto the Main body, make sure to push the three Hooks of the Front cover into the three "A" of the Side cover R ASSY.



**Fig. 5-31**

## 8.10 Control Panel Cover ASSY

- (1) Remove the four Taptite cup S M3x6 SR screws and LED FG harness ASSY.
- (2) Release the three Hooks to remove the Main shield cover plate ASSY from the Main body.

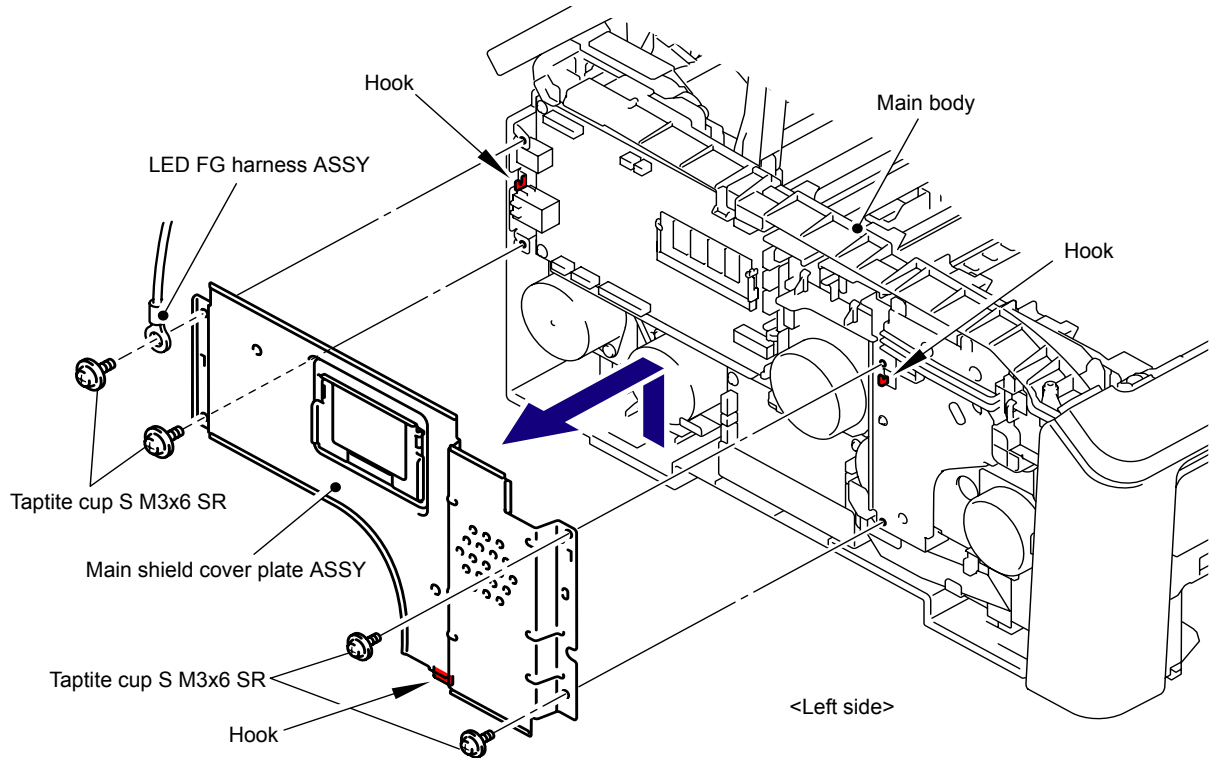

Fig. 5-32

**Note:**

After removing the Main shield cover plate ASSY, do not set up the main body with the left side down. The machine may get damaged due to load applied to the paper feed motor.

- (3) Disconnect the three Connectors (CN1, CN2, CN3) and cables from the Main PCB ASSY.  
(CN1, CN2: HL-3070CW only)

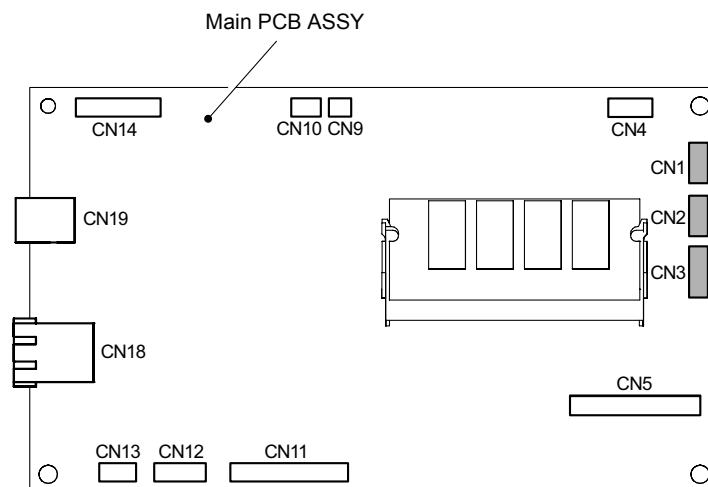

Fig. 5-33

- (4) Remove the two Taptite bind B M4x12 screws and five front Hooks, and slowly lift the Control panel cover ASSY to the direction of 4a, and then remove it from the Main body.

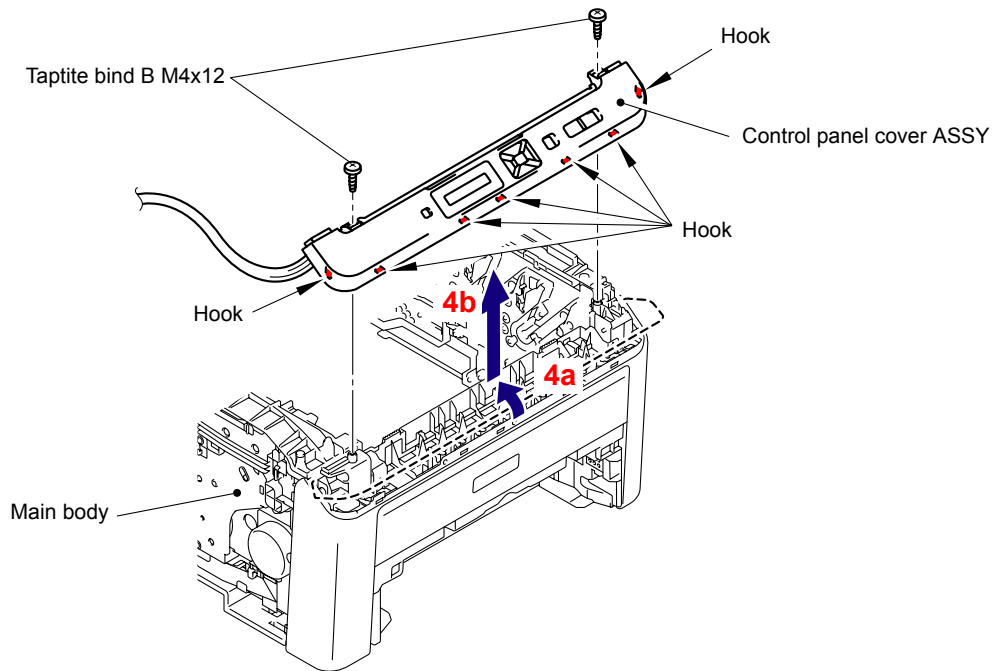

Fig. 5-34

**Harness routing:** Refer to "[11](#), [12](#) Control Panel Cover ASSY (HL-3070CW only)."  
Refer to "[13](#) Control Panel Cover ASSY (HL-3040CN only)."

## 8.11 Wireless LAN PCB ASSY (HL-3070CW only)

- (1) Disconnect the all cables in the USB holder.
- (2) Release the Hook and hold up the Wireless LAN PCB ASSY slightly in the direction of the arrow 2.
- (3) Turn over the Panel harness protective sheet in the direction of the arrow 3.
- (4) Remove the Wireless LAN PCB ASSY from the Control panel cover ASSY.

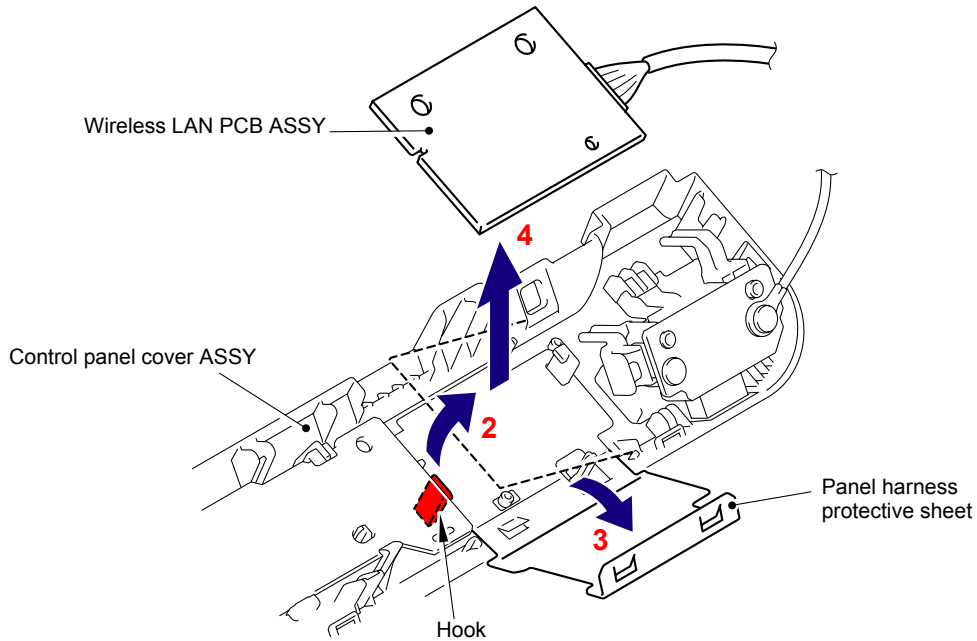

Fig. 5-35

- (5) Remove the Panel harness protective sheet from the Control panel cover ASSY.

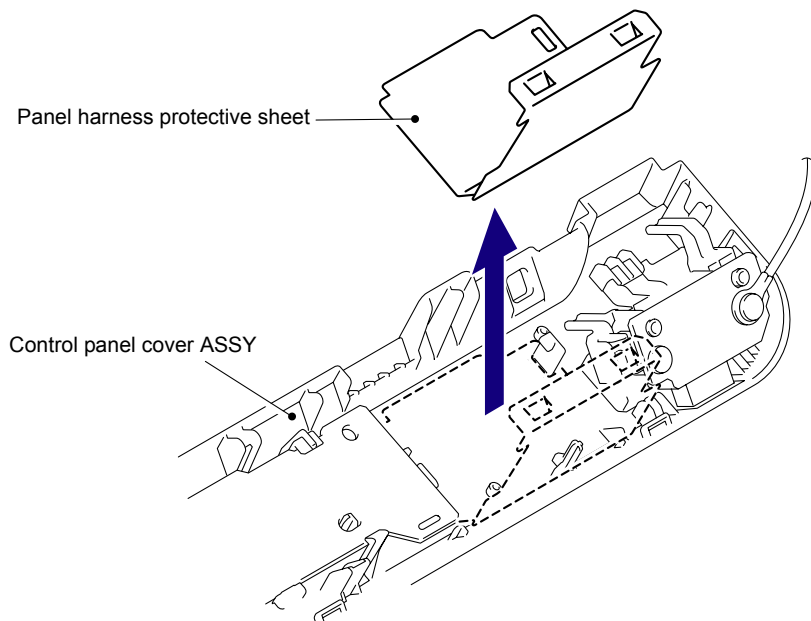
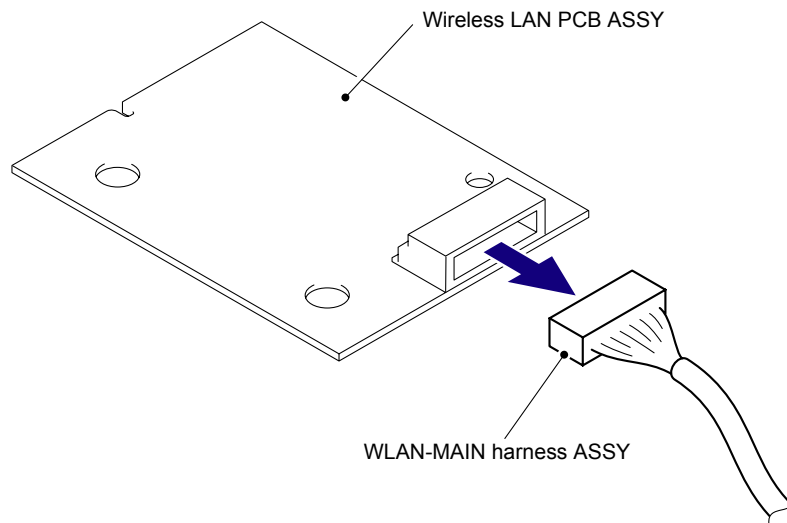

Fig. 5-36

- (6) Disconnect the connector of the WLAN-MAIN harness ASSY from the Wireless LAN PCB ASSY.



**Fig. 5-37**

**Harness routing:** Refer to "[12 Control Panel Cover ASSY \(HL-3070CW only\) \(Wireless LAN PCB ASSY, Panel PCB ASSY\)](#)."

## 8.12 Panel PCB ASSY

- (1) Release the three Hooks to remove the Panel PCB ASSY from the Control panel cover ASSY.

**Note:**

Be careful that the Flat cable of the LCD is connected to the Panel PCB ASSY.

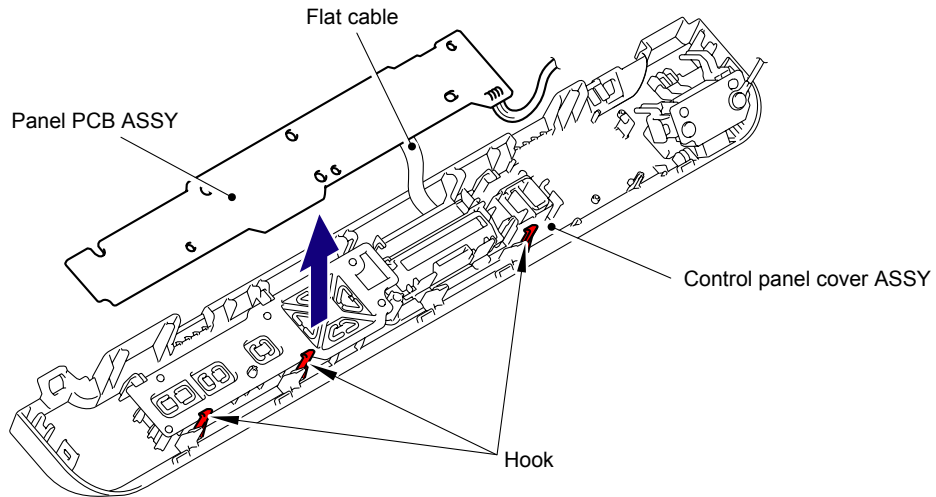
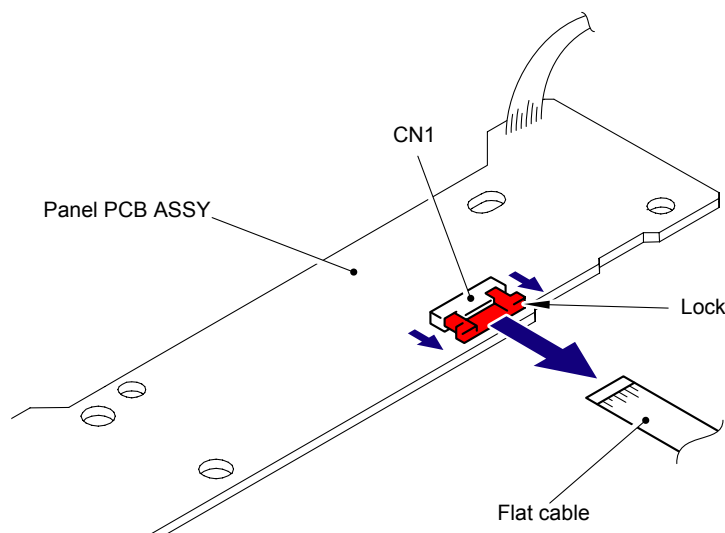

**Fig. 5-38**

- (2) Release the Lock and disconnect the Flat cable (CN1) from the Panel PCB ASSY.

**Note:**

- After disconnecting the flat cable(s), check that each cable is not damaged at its end or short-circuited.
- When connecting the flat cable(s), do not insert it at an angle. After insertion, check that the cable is not at an angle.



**Fig. 5-39**

**Harness routing:** Refer to "[12 Control Panel Cover ASSY \(HL-3070CW only\).](#)"

Refer to "[13 Control Panel Cover ASSY \(HL-3040CN only\).](#)"

# 8.13 Rubber Key Printed ASSY

(1) Remove the Rubber key printed ASSY from the Control panel cover ASSY.

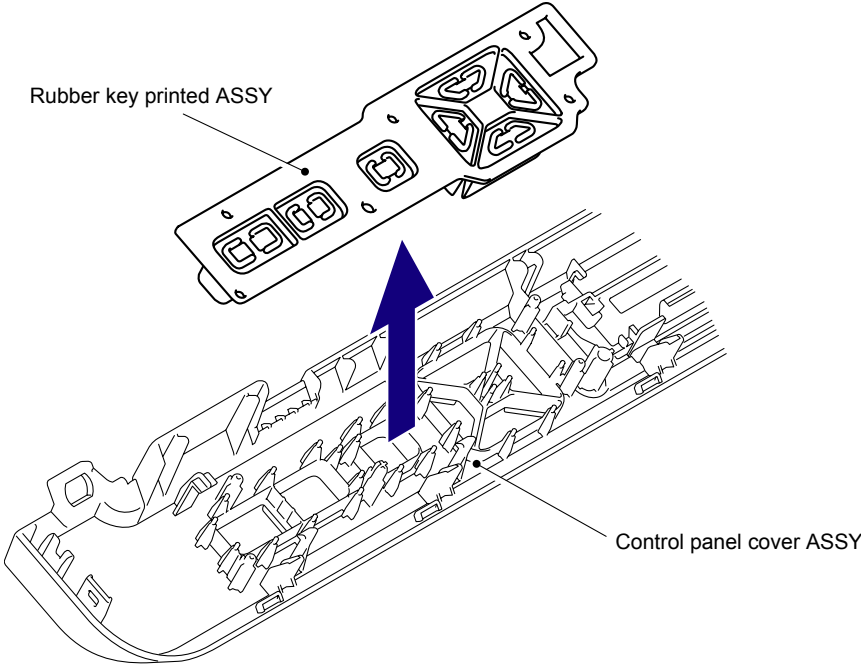

Fig. 5-40

# 8.14 LCD/Back Light Film

<HL-3070CW>

(1) Release the two Hooks to remove the LCD holder from the Control panel cover ASSY.

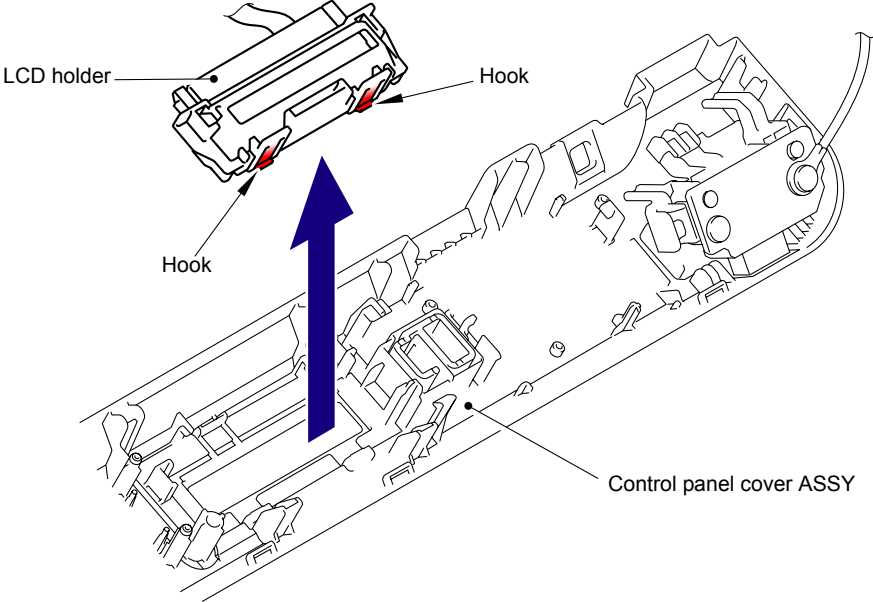

Fig. 5-41

(2) Release the two Hooks to remove the LCD and Back light film from the LCD holder.

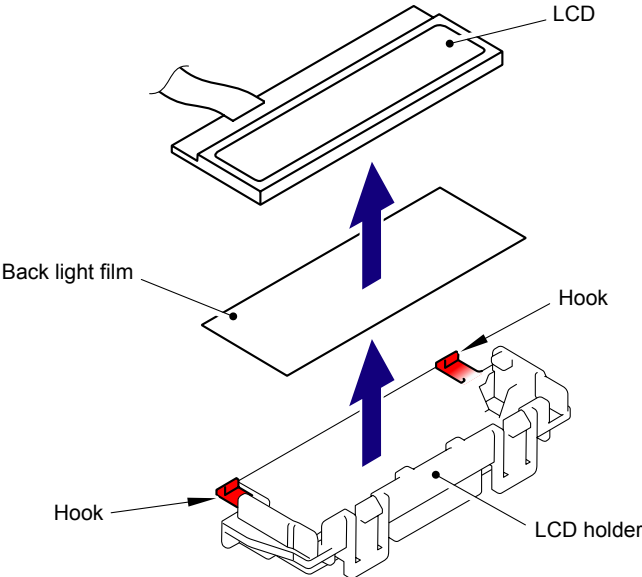
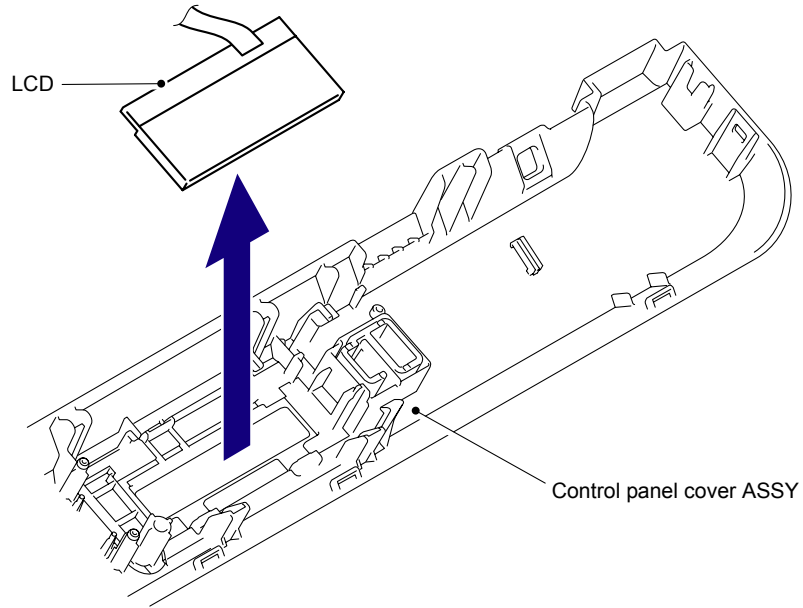

Fig. 5-42



**<HL-3040CN >**

- (1) Release the two Hooks to remove the LCD from the Control panel cover ASSY.



**Fig. 5-43**

## 8.15 USB Direct Interface Relay PCB ASSY (HL-3070CW only)

- (1) Remove the two Taptite bind B M3x8 screws and FG harness.
- (2) Remove the USB direct interface relay PCB ASSY from the Control panel cover ASSY.

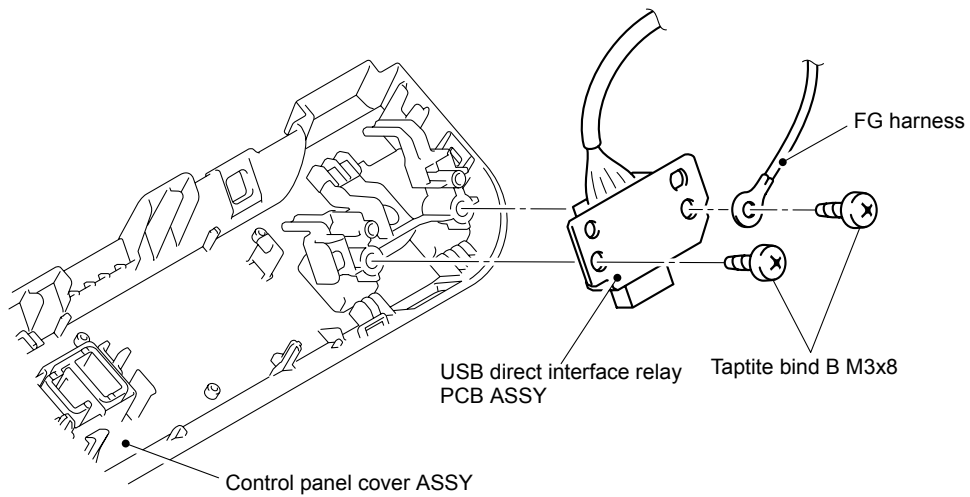

Fig. 5-44

- (3) Disconnect the Connector of the USB A-MAIN relay harness ASSY from the USB direct interface relay PCB ASSY.

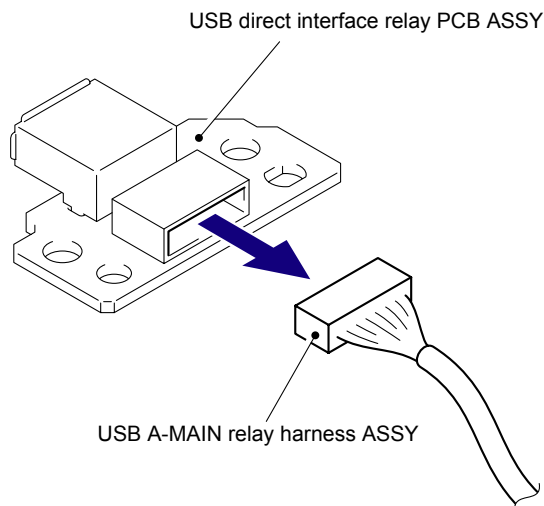

Fig. 5-45

**Harness routing:** Refer to “[11 Control Panel Cover ASSY \(HL-3070CW only\) \(USB Direct Interface Relay PCB ASSY\).](#)”

# 8.16 Panel Light Guide

(1) Remove the Panel light guide from the Control panel cover ASSY.

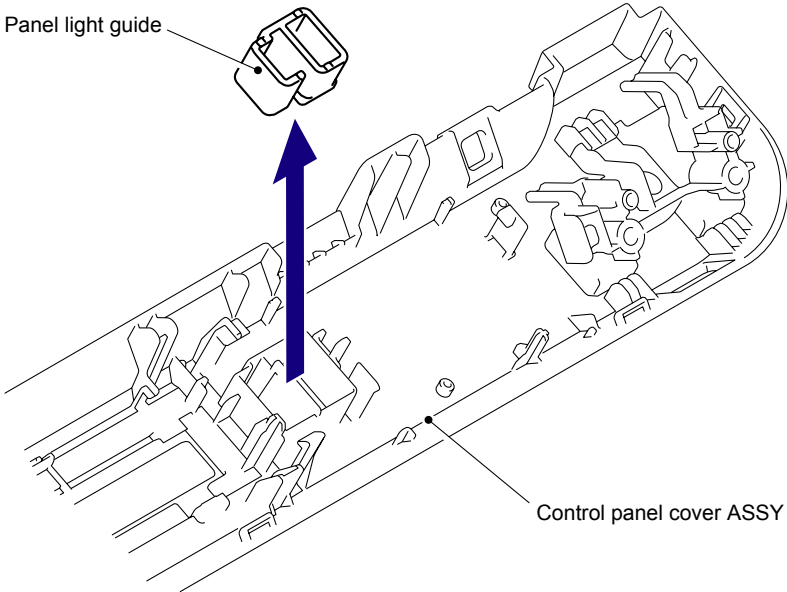

Fig. 5-46

(2) Remove the two Taptite bind B M3x8 screws, and then remove the USB holder from the Control panel cover ASSY.

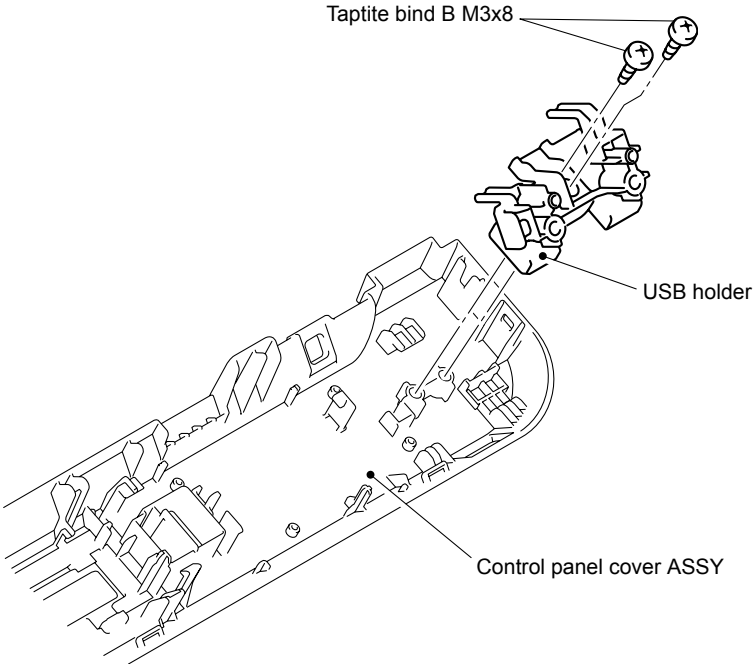

Fig. 5-47

# 8.17 Front Cover

(1) Disconnect the Connector (CN4) from the Main PCB ASSY.

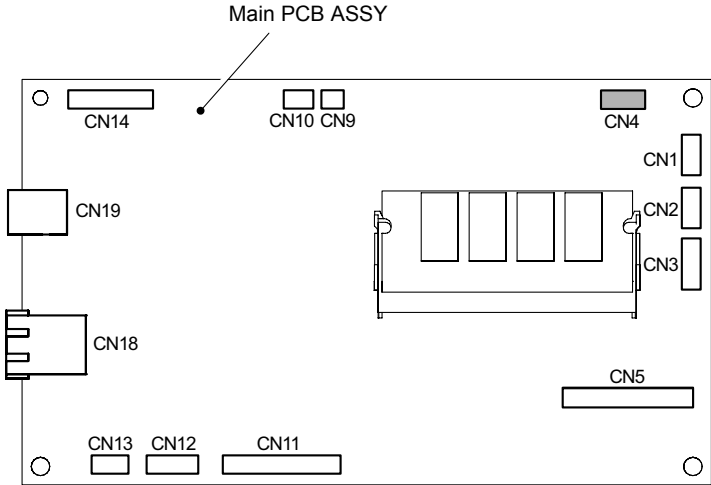

Fig. 5-48

(2) Disconnect the Connector (CN13) and cables from the Engine PCB ASSY.

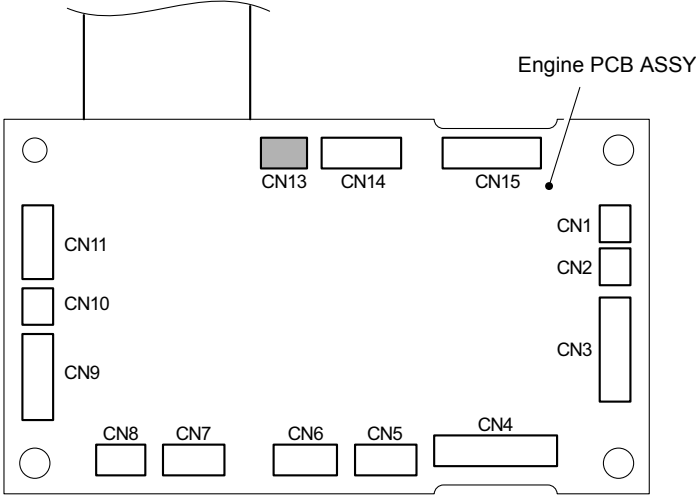
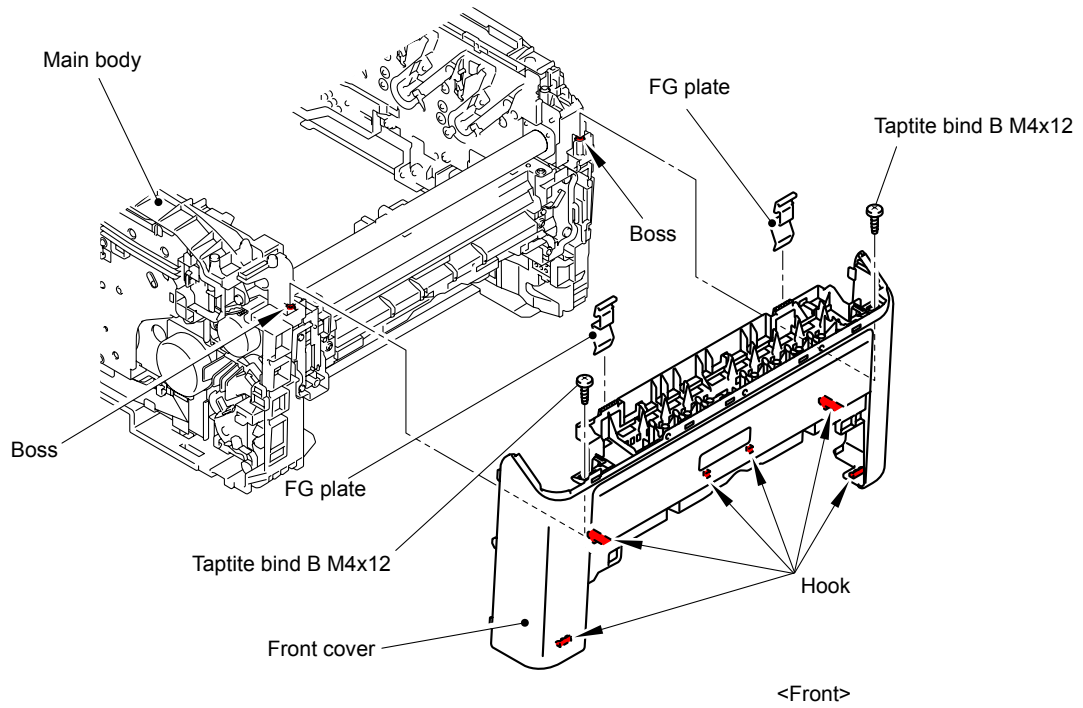

Fig. 5-49

- (3) Remove the two Taptite bind B M4x12 screws from the Front cover.
- (4) Release the six Hooks and two Bosses to remove the Front cover from the Main body.
- (5) Remove the two FG plate from the Front cover.



**Fig. 5-50**

# 8.18 Manual Feed Slot ASSY

(1) Release the two Bosses to remove the Manual feed slot ASSY from the Front cover.

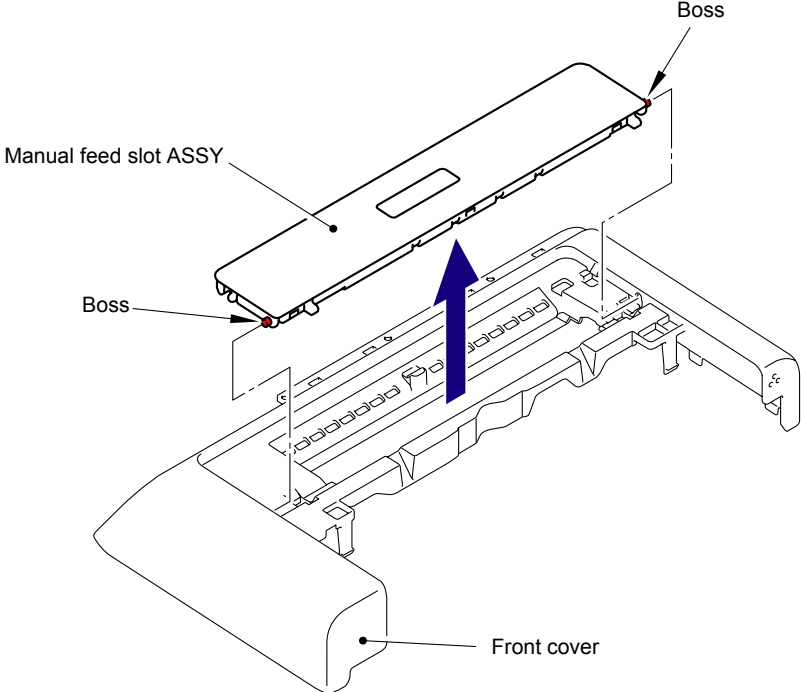

Fig. 5-51

# 8.19 TC Arm Spring

(1) Disconnect the FFC harness:MAIN-LED CTL (CN14) from the Main PCB ASSY.

**Note:**

- After disconnecting the flat cable(s), check that each cable is not damaged at its end or short-circuited.
- When connecting the flat cable(s), do not insert it at an angle. After insertion, check that the cable is not at an angle.

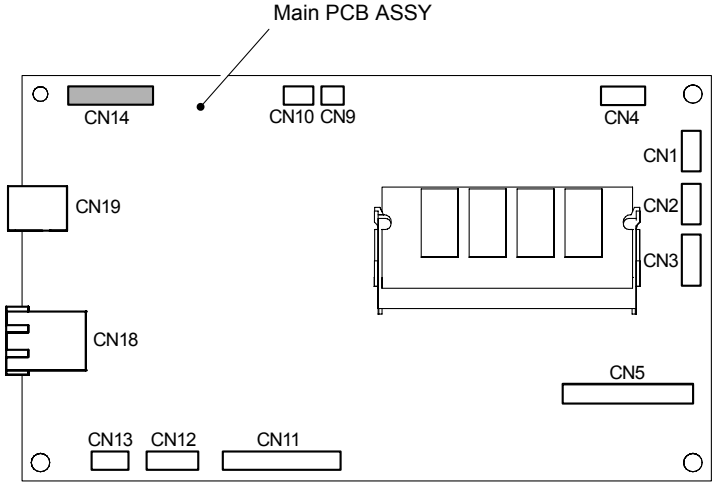

Fig. 5-52

(2) Release the Hook to remove the LED power relay PCB ASSY from the Side frame L.

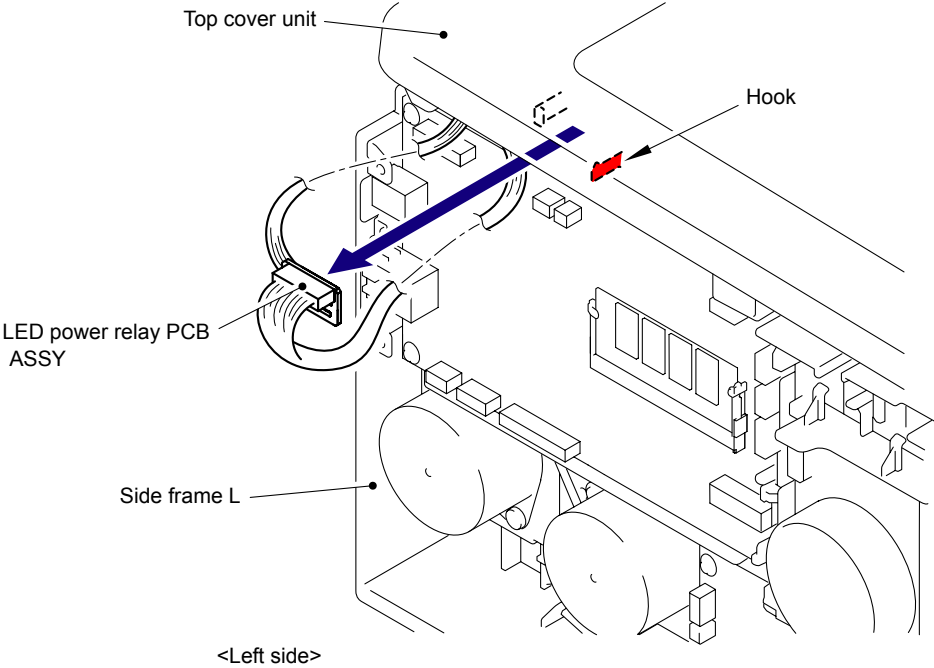

Fig. 5-53

(3) Disconnect the Connector from the LED power relay PCB ASSY.

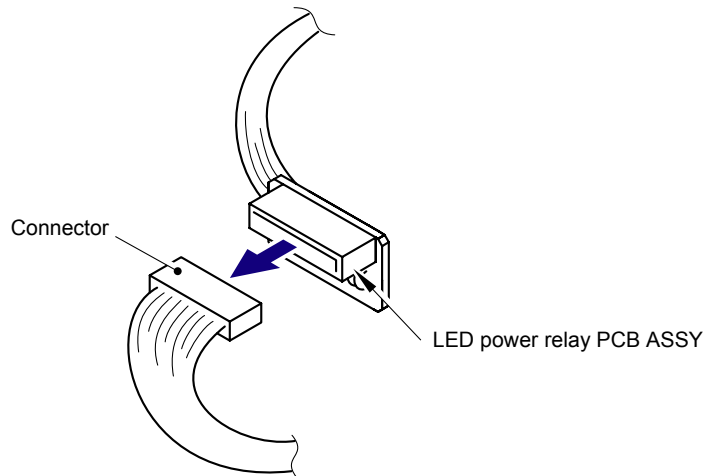

Fig. 5-54

(4) Remove the Relay-LED harness ASSY of the Top cover unit and FFC harness:MAIN-LED CTL from the Side frame L.

**Note:**

- After disconnecting the flat cable(s), check that each cable is not damaged at its end or short-circuited.
- When connecting the flat cable(s), do not insert it at an angle. After insertion, check that the cable is not at an angle.

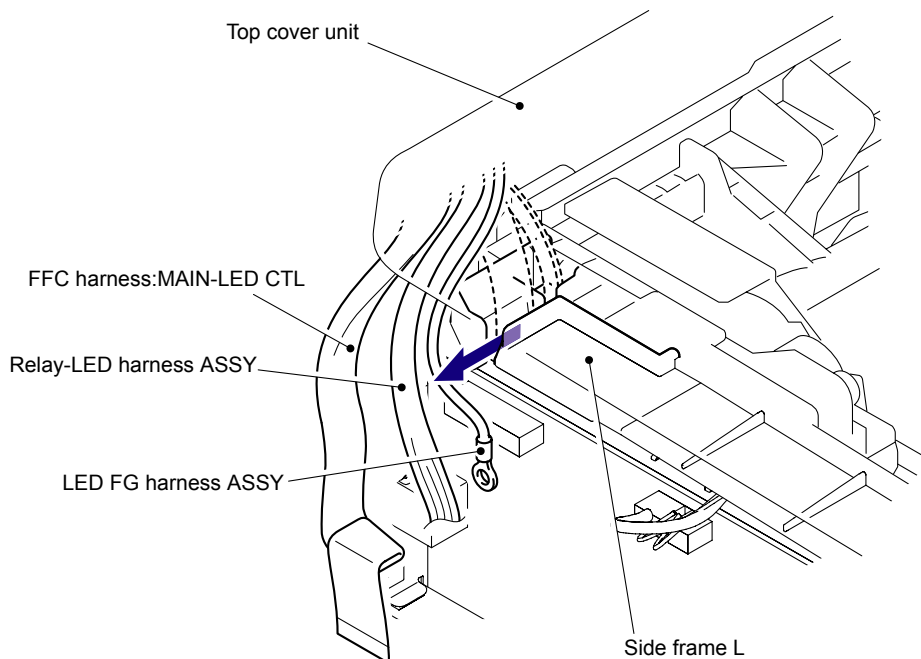

Fig. 5-55

**Harness routing:** Refer to "1 Top Cover Unit."



(5) Remove the TC arm spring L from the Top cover arm L.

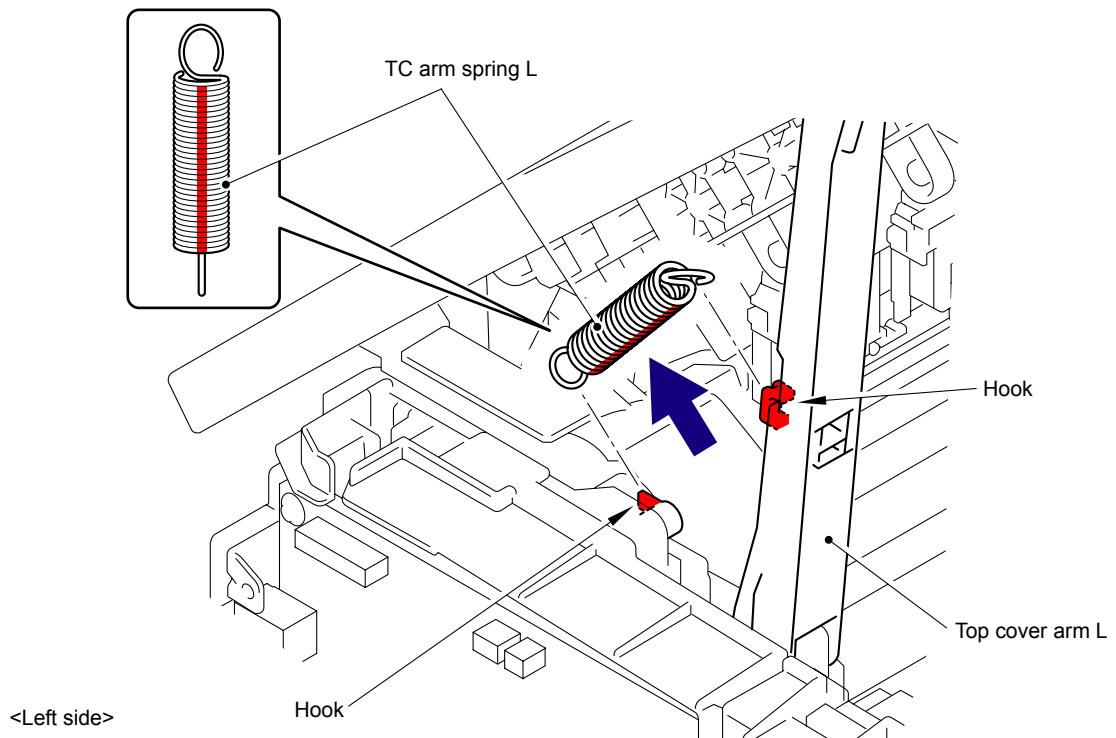

Fig. 5-56

**Assembling Note:**

The TC arm spring L and TC arm spring R are different parts. Make sure to assemble the spring with a red line on its side to the L side.

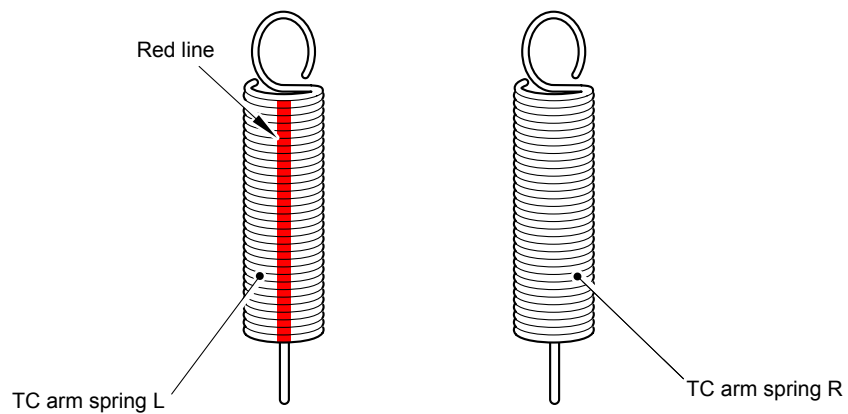
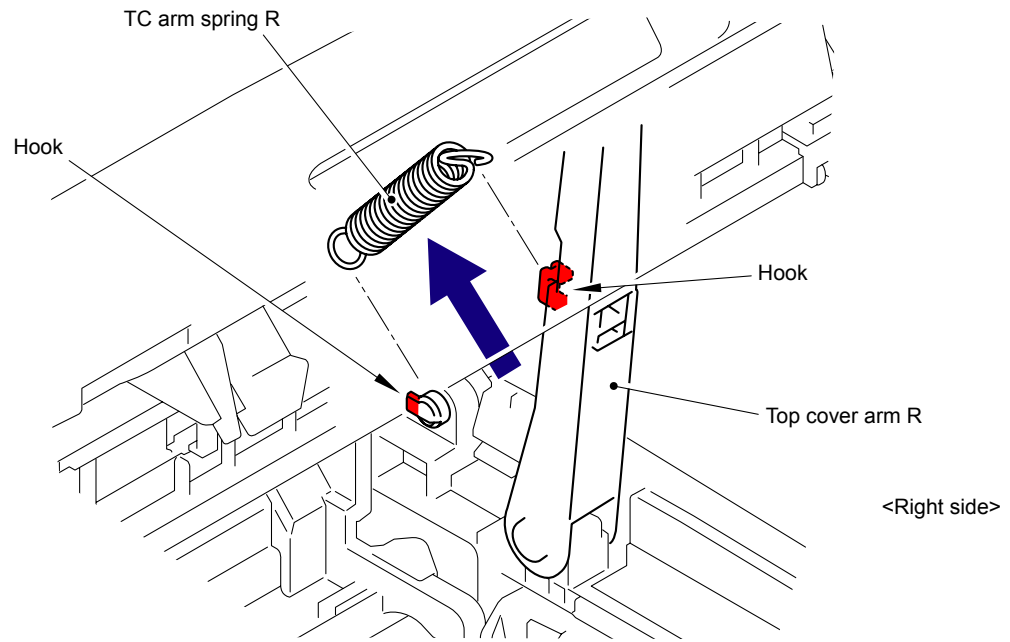

Fig. 5-57

(6) Remove the TC arm spring R from the Top cover arm R.



**Fig. 5-58**

# 8.20 Arm Guide L Cover

(1) Remove the Arm guide L cover from the Arm guide L.

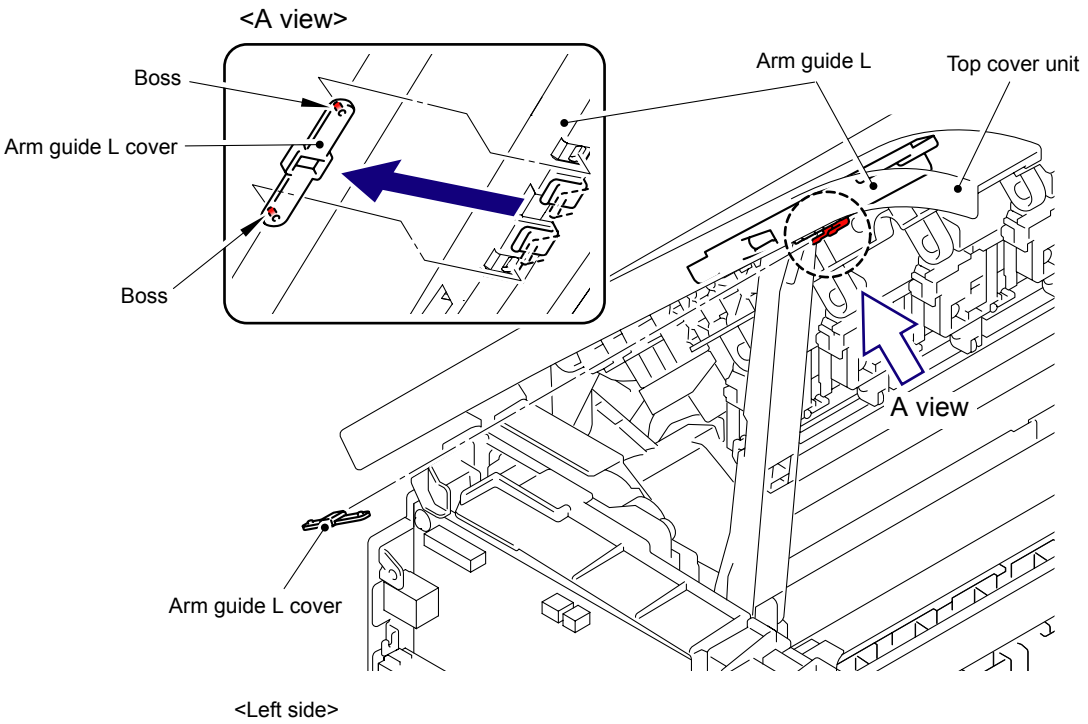

Fig. 5-59

# 8.21 Top Cover Sub ASSY

(1) Remove the Pin of the Top cover arm L from the "A" of the Arm guide L.

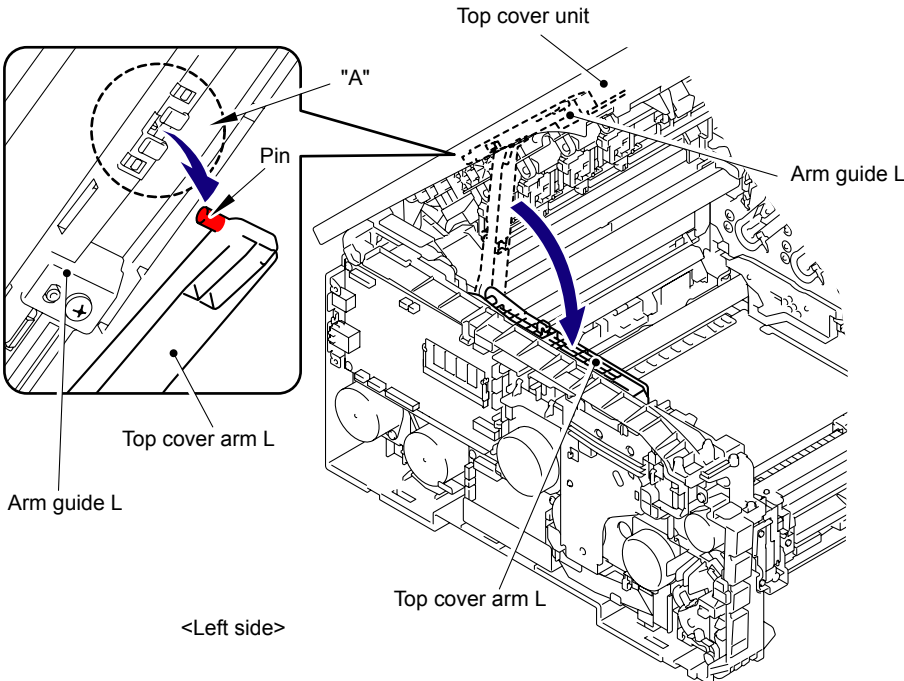

Fig. 5-60

(2) Remove the Pin of the Top cover arm R from the "B" of the Arm guide R.

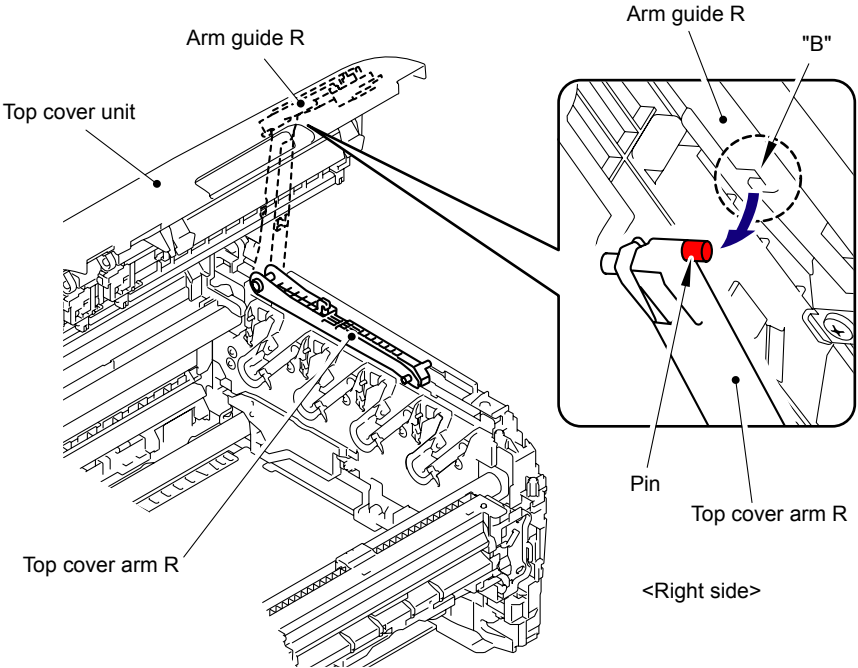
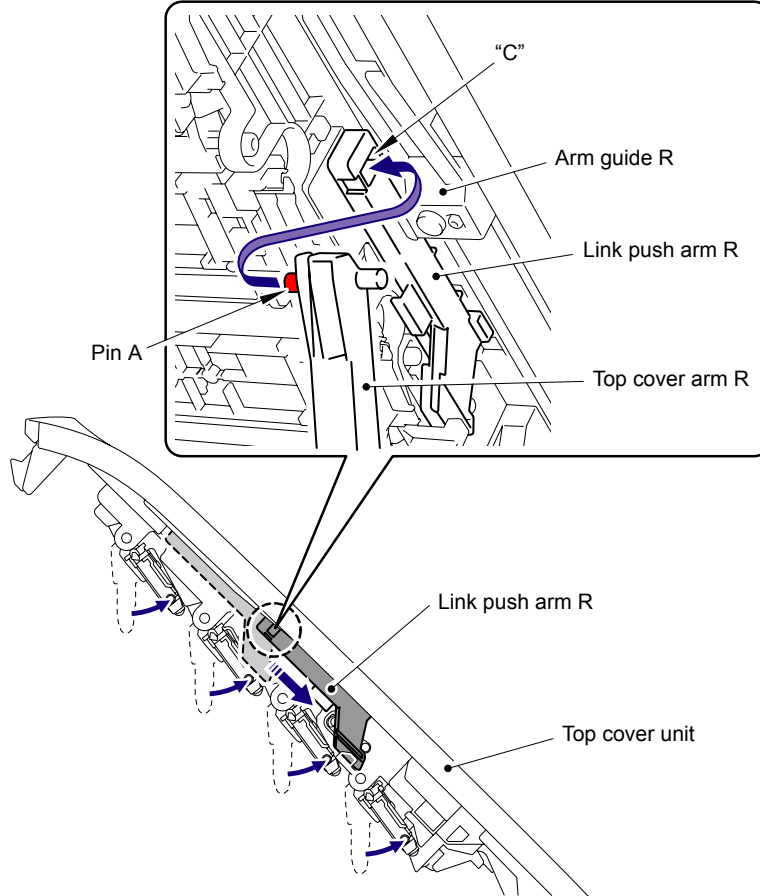

Fig. 5-61

**Assembling Note:**

When assembling the Arm guide R onto the Top cover arm R, make sure to follow the procedure described below.

- 1) Slide the Link push arm to the rearmost and insert Pin A of the Top cover arm R to "C" of the link push arm.



**Fig. 5-62**

- 2) Be sure to mount it by inserting Pin B of the top cover arm R into "B" of the arm guide R.

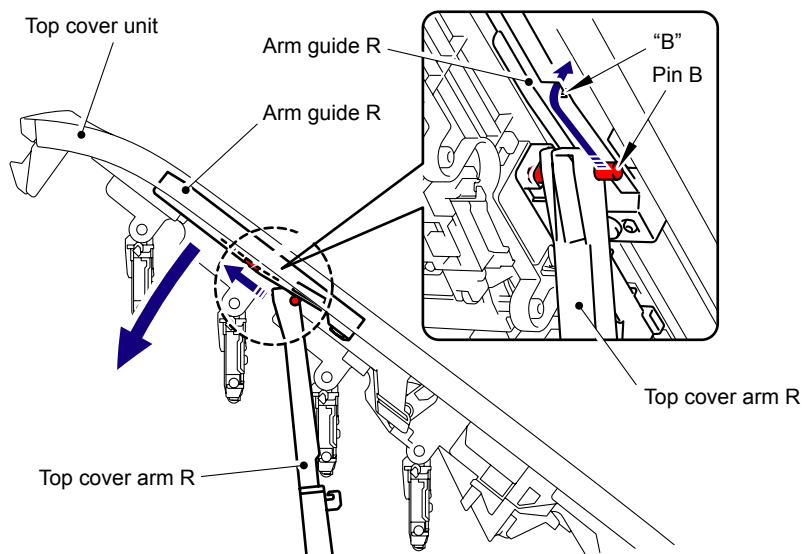

**Fig. 5-63**

(3) Remove the Top cover sub ASSY from the Main body.

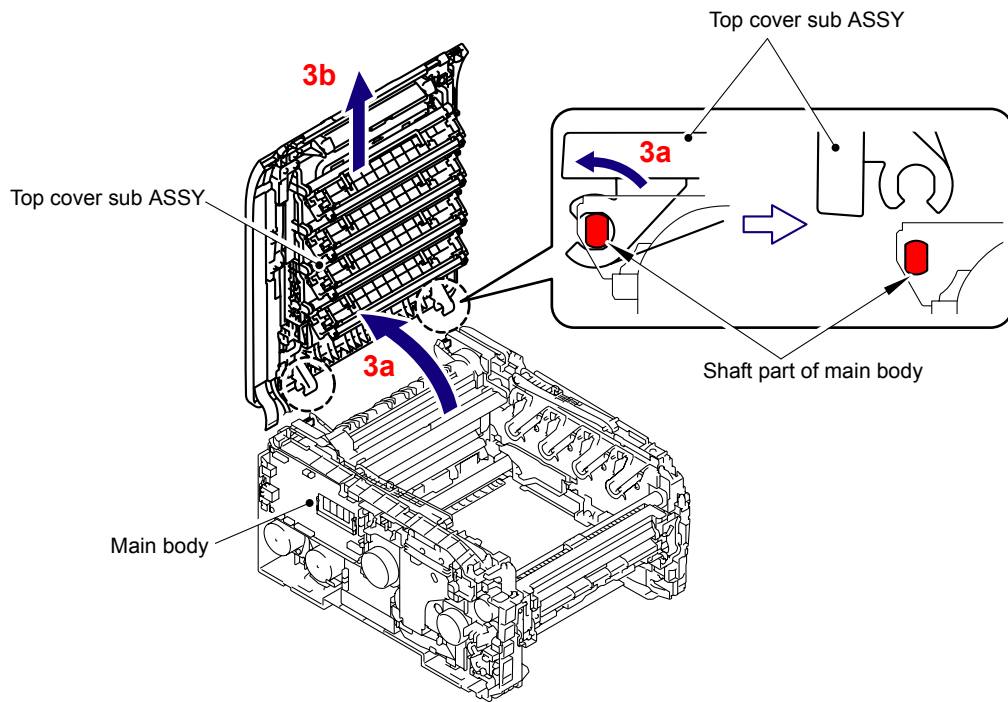

Fig. 5-64

**Harness routing:** Refer to "[1 Top Cover Unit.](#)"

## 8.22 Inner Chute 2 ASSY

- (1) Remove the two Taptite bind B M4x12 screws from the Inner chute 2 ASSY.
- (2) Release the two Bosses to remove the Inner chute 2 ASSY from the Top cover sub ASSY.

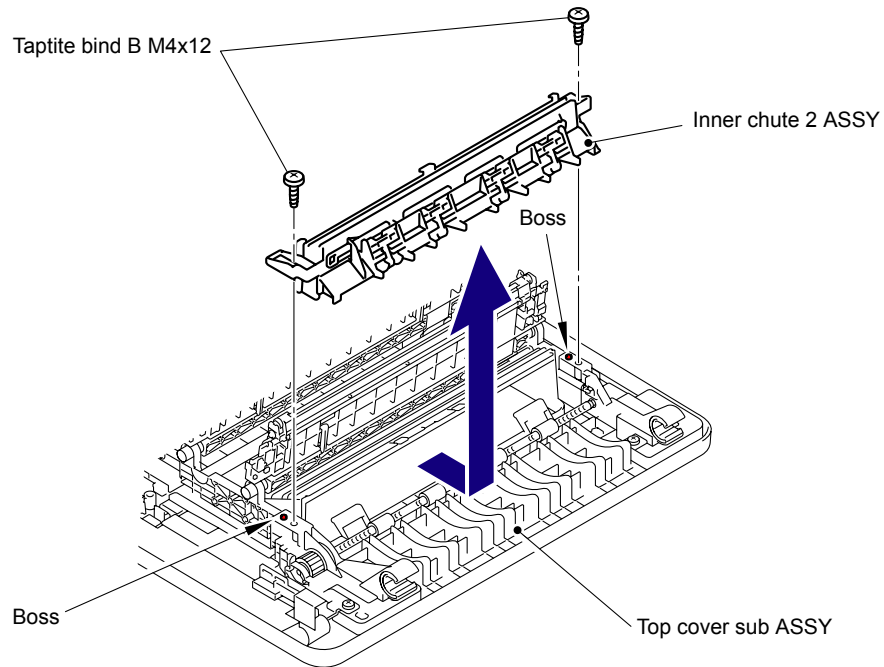

Fig. 5-65

### Assembling Note:

When assembling the Inner chute 2 ASSY, make sure to assemble it in a way that the two "A" of the Top cover sub ASSY come above the Inner chute 2 ASSY.

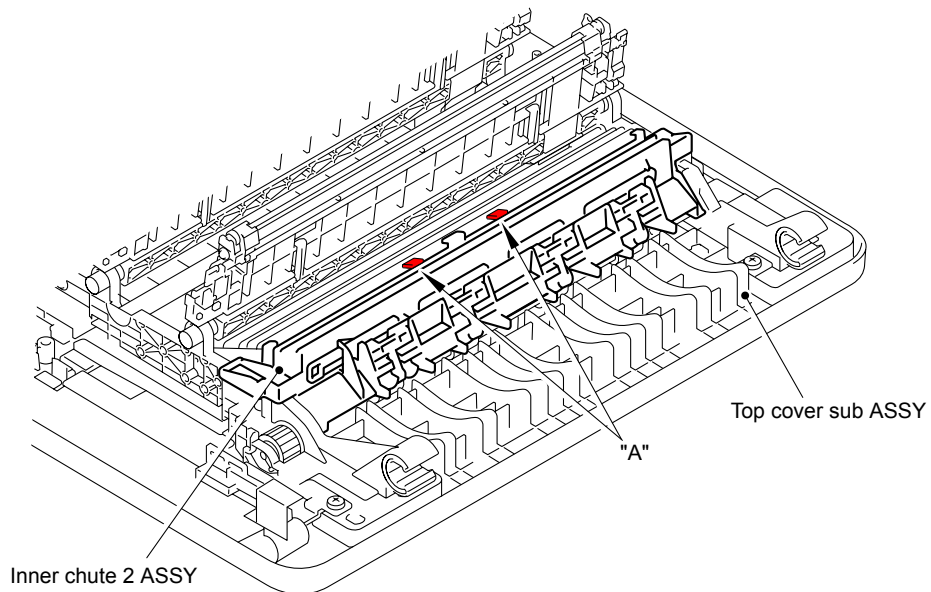

Fig. 5-66

## 8.23 FFC Harness:MAIN-LED CTL

- (1) Remove the two Taptite bind B M4x12 screws, and then remove the Arm guide L from the Top cover sub ASSY.

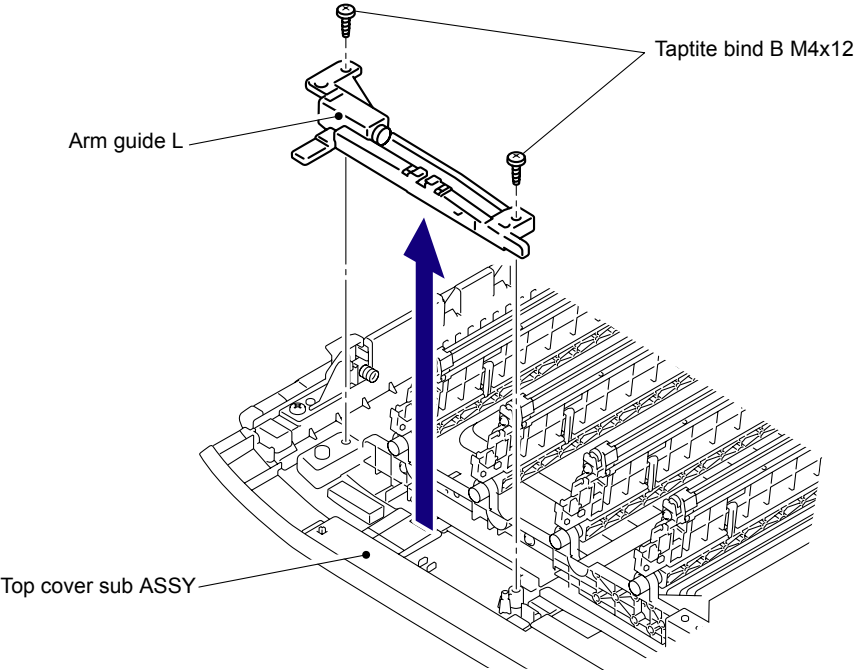

Fig. 5-67

- (2) Remove the Taptite bind B M4x12 screw, and then remove the TC harness cover from the Top cover sub ASSY.

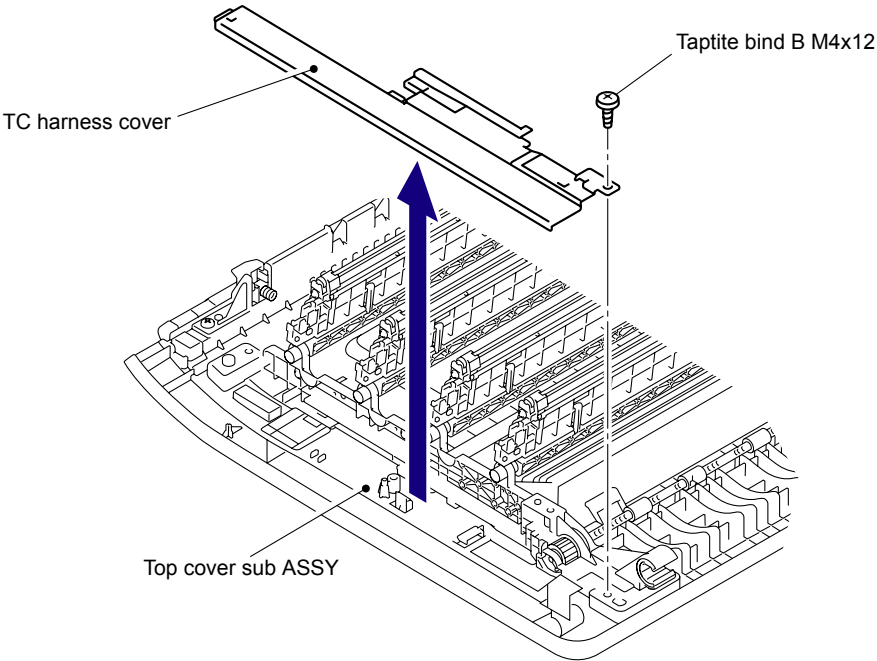
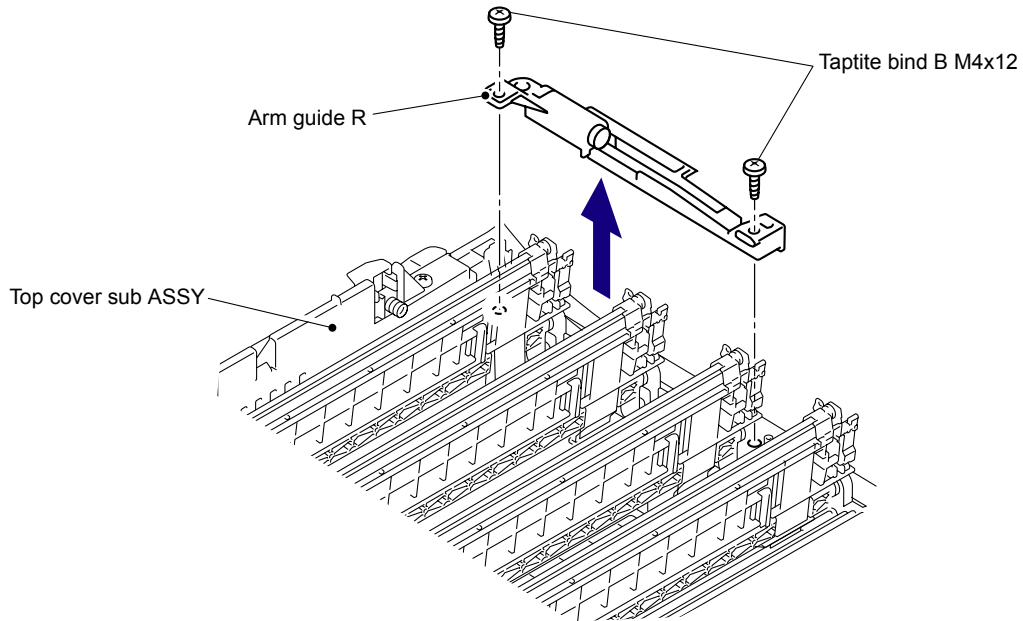

Fig. 5-68



- (3) Remove the two Taptite bind B M4x12 screws, and then remove the Arm guide R from the Top cover sub ASSY.



**Fig. 5-69**

- (4) Remove the three Taptite bind B M4x12 screws, and then remove the Sub frame ASSY from the Top cover sub ASSY.

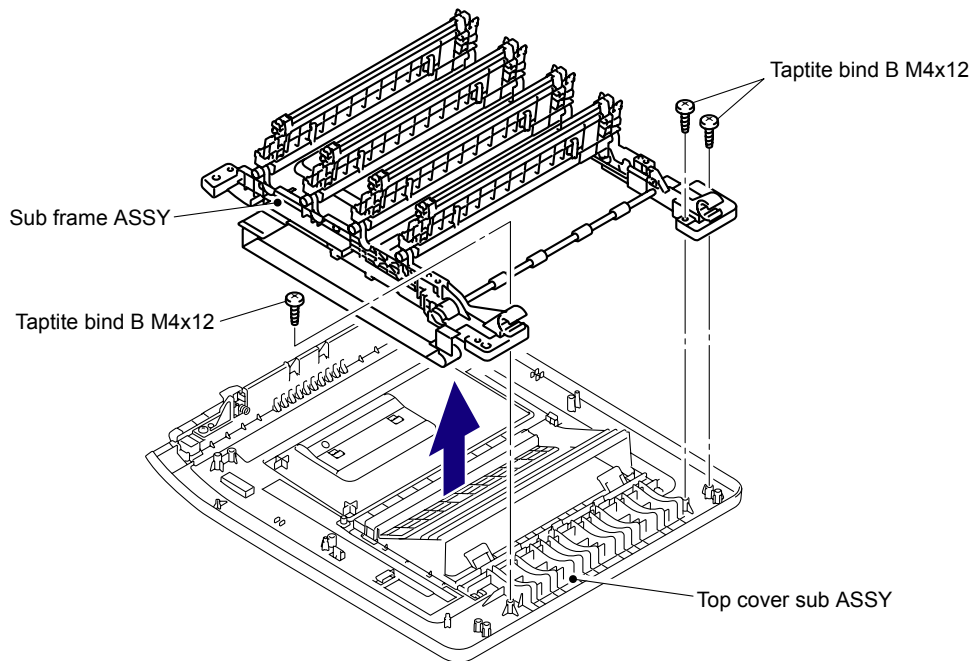

**Fig. 5-70**

- (5) Insert the two "A" of the removed Sub frame ASSY into the two "B" of the Main body and close it as shown in the figure below.

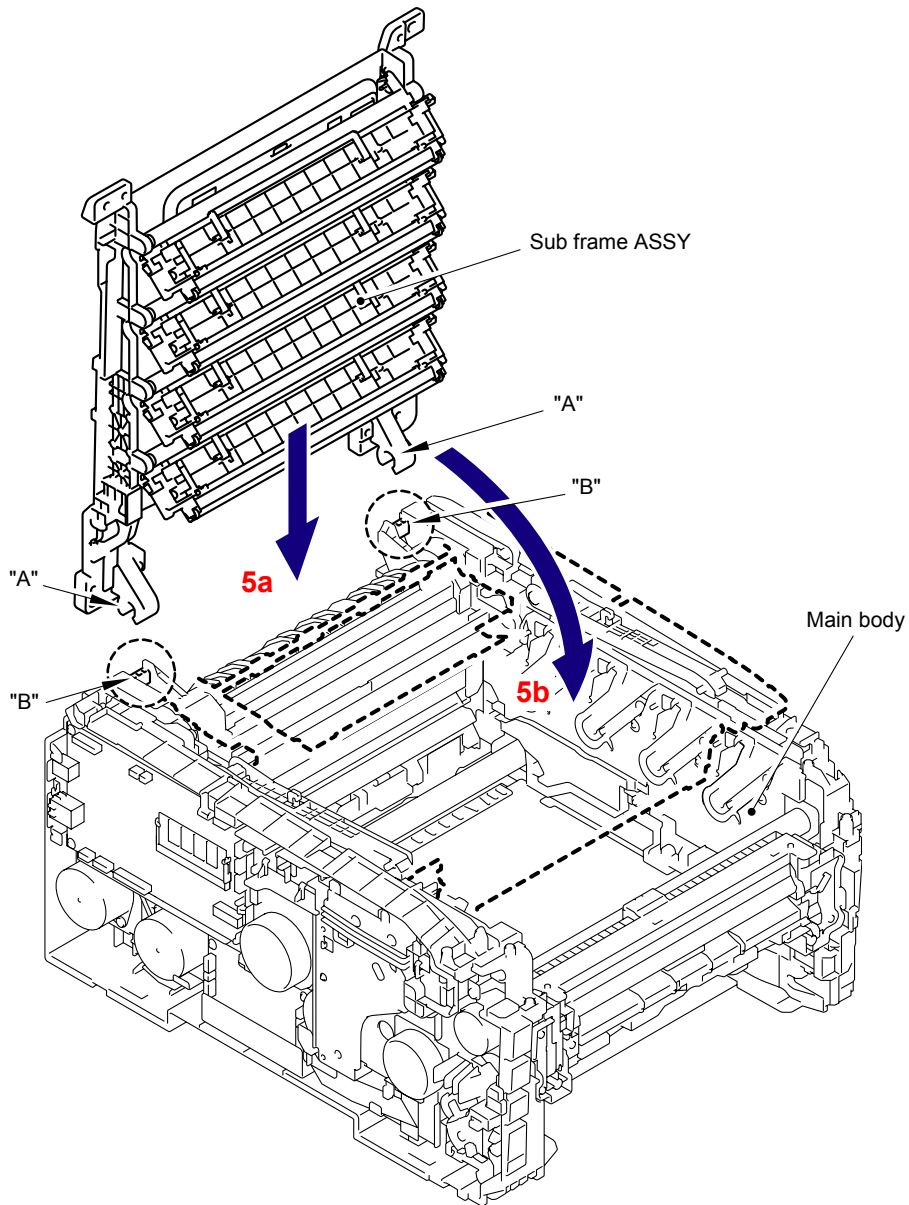

Fig. 5-71

- (6) Remove the four Taptite cup S M3x6 SR screws, and then remove the LED PCB cover and Insulation sheet B from the Sub frame ASSY.

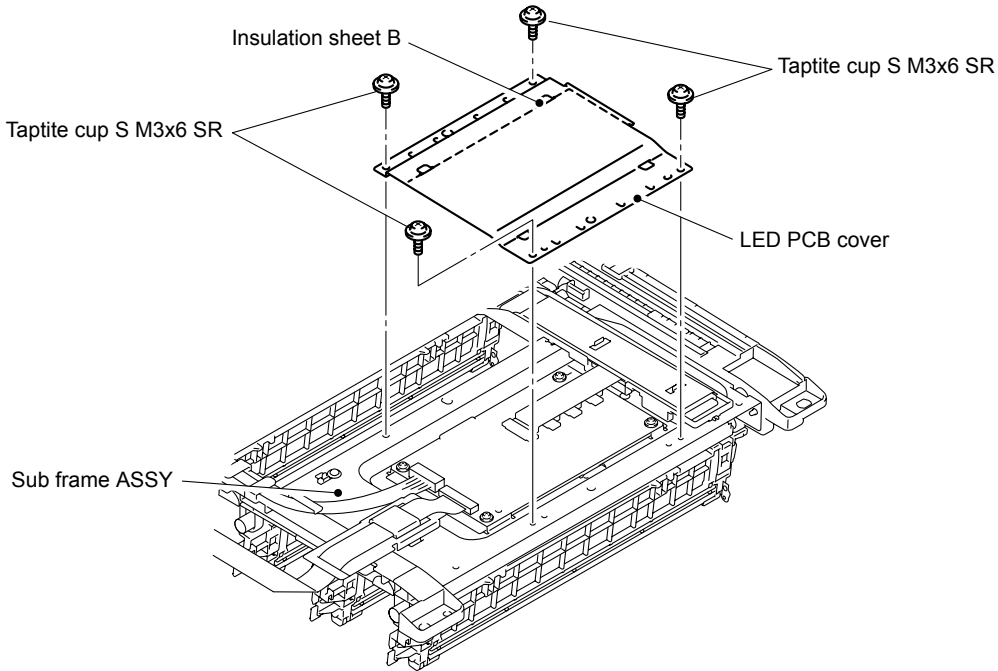

Fig. 5-72

- (7) Disconnect the FFC harness:MAIN-LED CTL (CN5) from the LED head control PCB ASSY.

**Note:**

- After disconnecting the flat cable(s), check that each cable is not damaged at its end or short-circuited.
- When connecting the flat cable(s), do not insert it at an angle. After insertion, check that the cable is not at an angle.

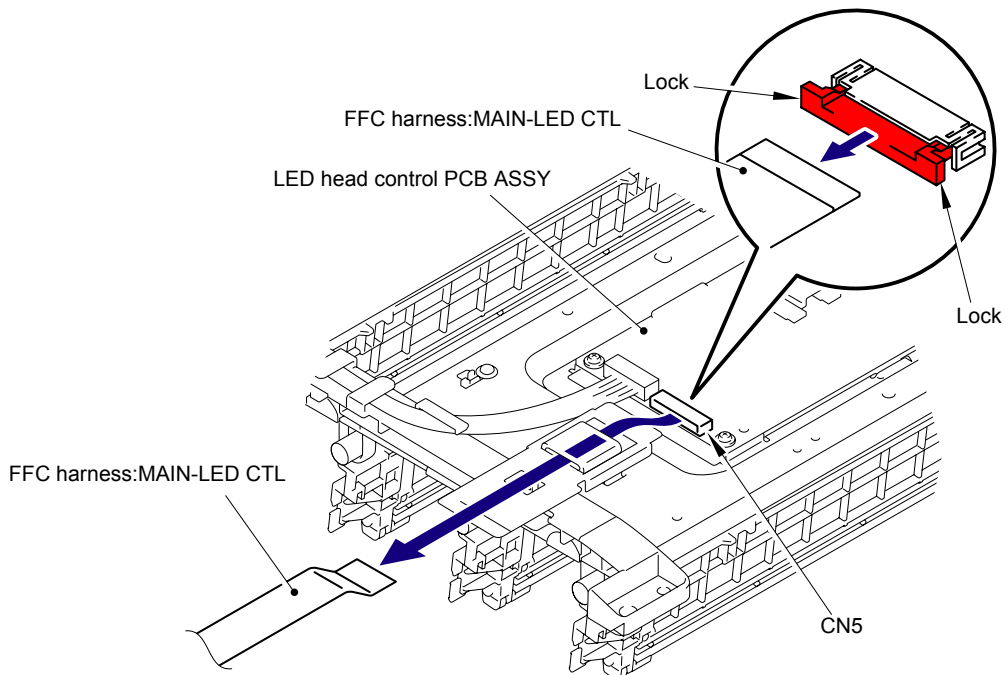
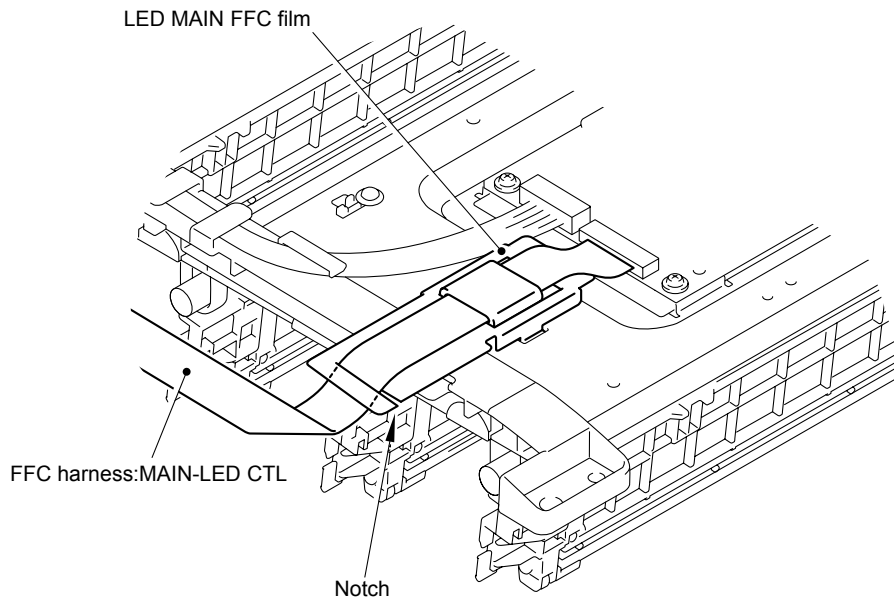

Fig. 5-73

**Assembling Note:**

After assembling the FFC harness:MAIN-LED CTL, be sure to pass the FFC harness: MAIN-LED CTL through the notch on the LED main FFC film.



**Fig. 5-74**

**Harness routing:** Refer to "1 Top Cover Unit."

# 8.24 LED Power Relay PCB ASSY

- (1) Disconnect the Connector (CN6) of the LED power relay PCB ASSY from the LED head control PCB ASSY.

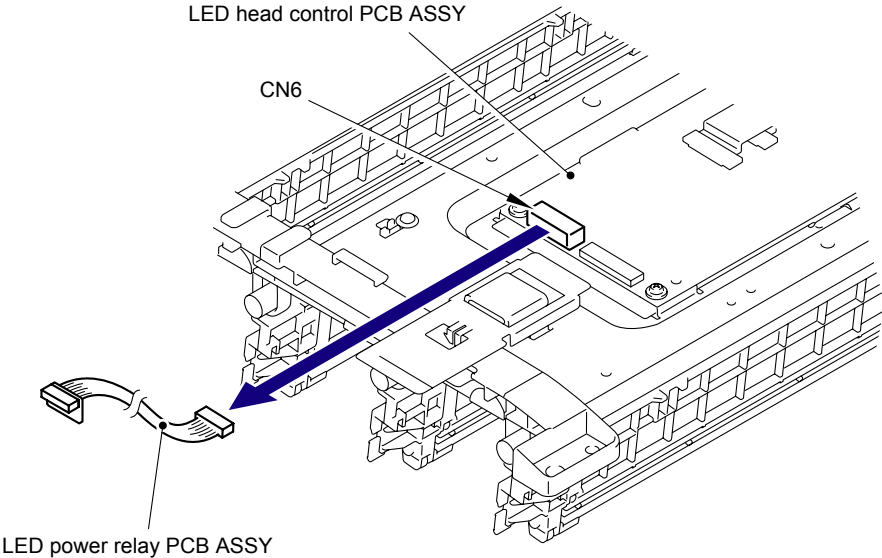

Fig. 5-75

# 8.25 LED Head Control PCB ASSY

(1) Remove the LED FFC cover film from the Sub frame ASSY.

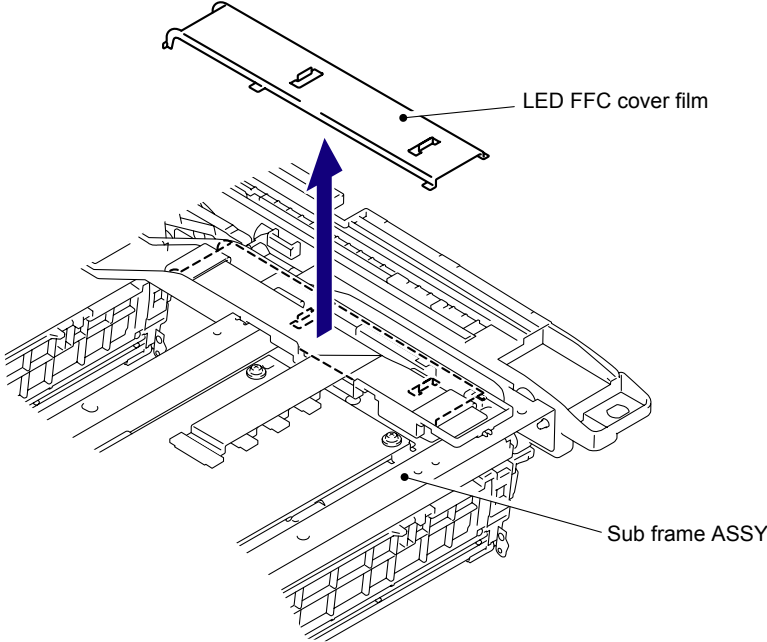

Fig. 5-76

(2) Disconnect the four FFC sheet (CN1, CN2, CN3, CN4) of the LED ASSY from the LED head control PCB ASSY.

**Note:**

- After disconnecting the flat cable(s), check that each cable is not damaged at its end or short-circuited.
- When connecting the flat cable(s), do not insert it at an angle. After insertion, check that the cable is not at an angle.

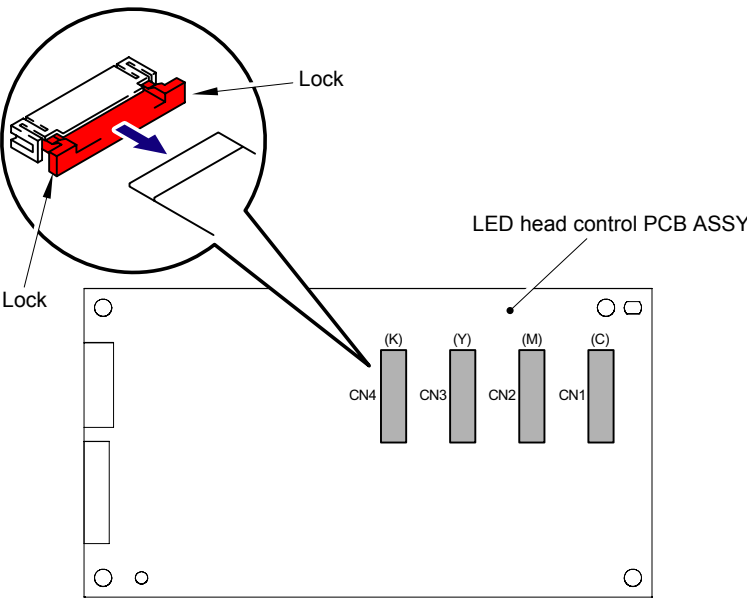
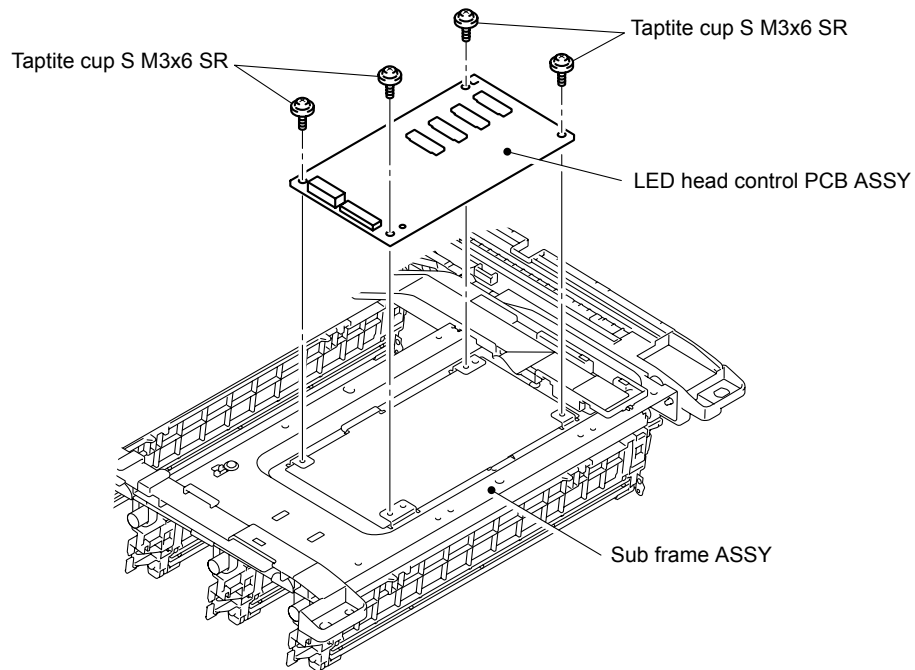

Fig. 5-77

- (3) Remove the four Taptite cup S M3x6 SR screws, and then remove the LED head control PCB ASSY from the Sub frame ASSY.



**Fig. 5-78**

# 8.26 LED ASSY/Holder Hook

- (1) Remove the four FFC sheet from the Sub frame ASSY, and remove the Cores from each of the FFC sheet.

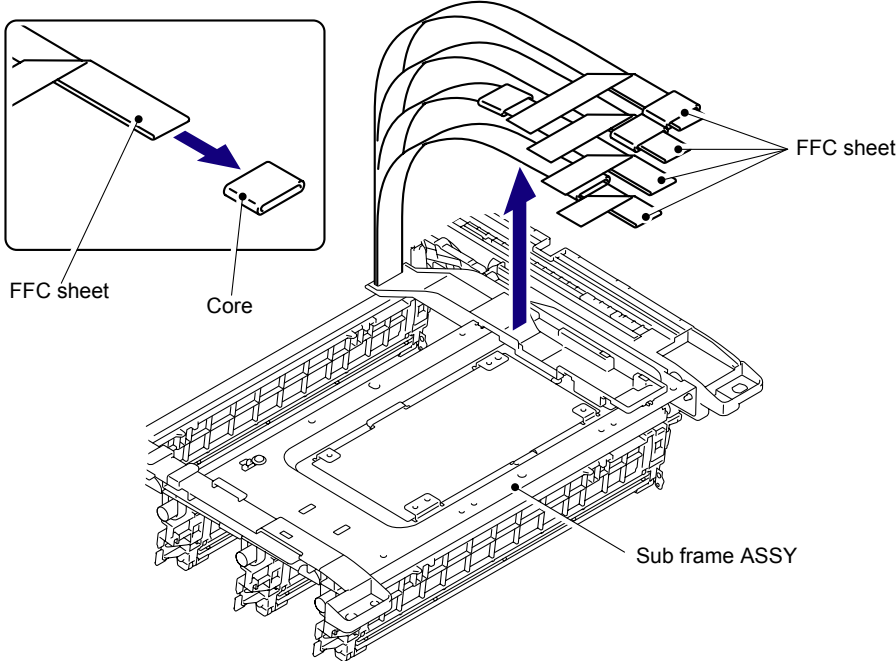

Fig. 5-79

- (2) Remove the Sub frame ASSY from the Main body, and place it with the LED ASSY side up.

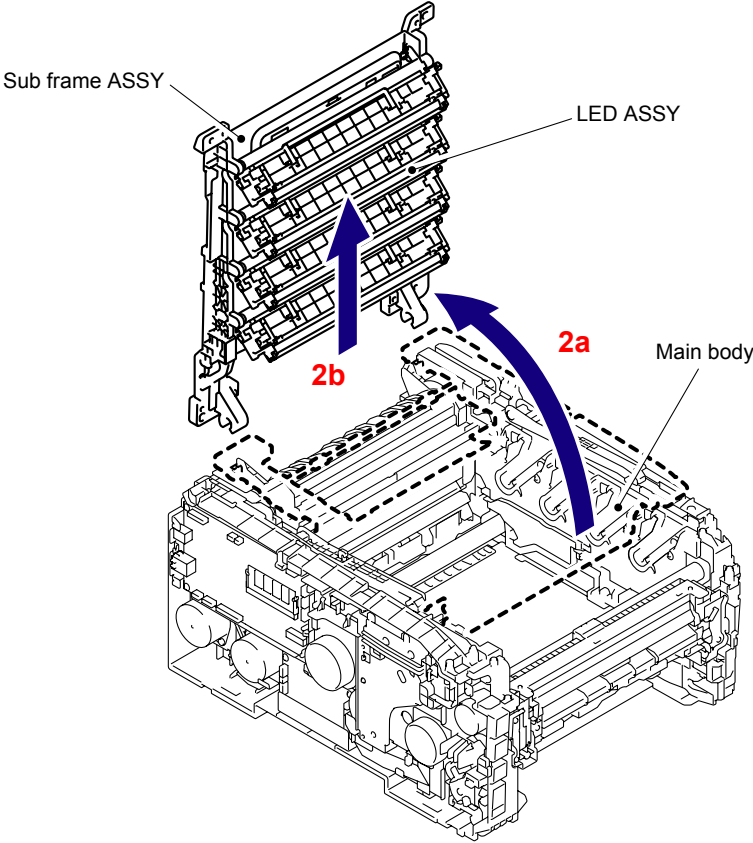

Fig. 5-80



- (3) Remove the Hook by the driver from the back side of the LED ASSY, and remove the Holder hook on the left side from the Holder and the LED ASSY.

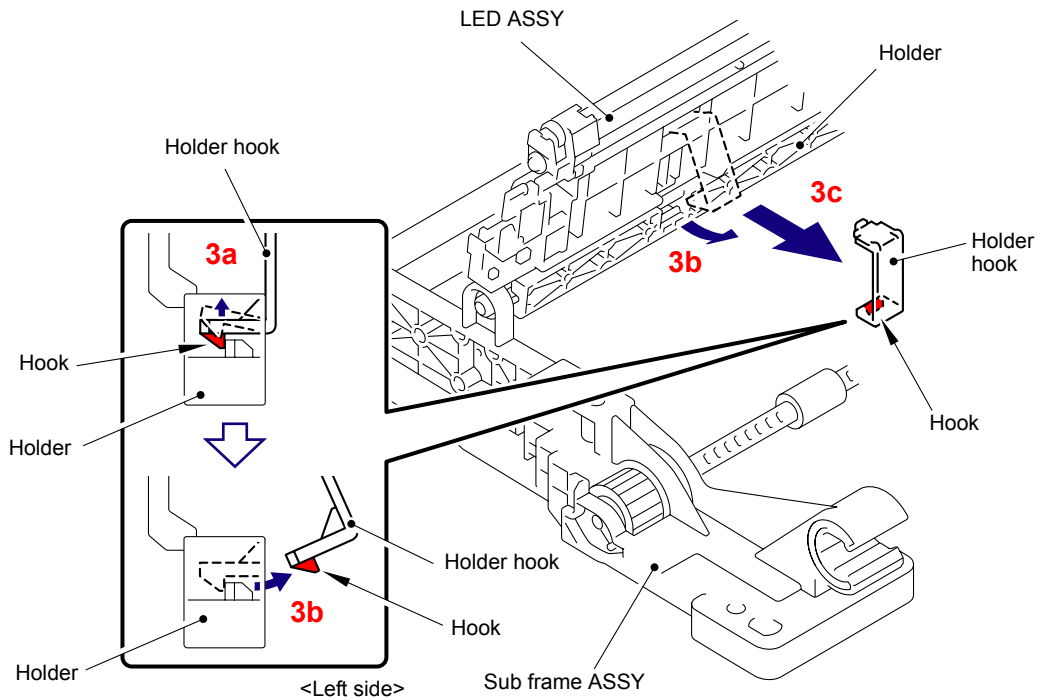

Fig. 5-81

- (4) Remove the Holder hook on the right side in the same way.

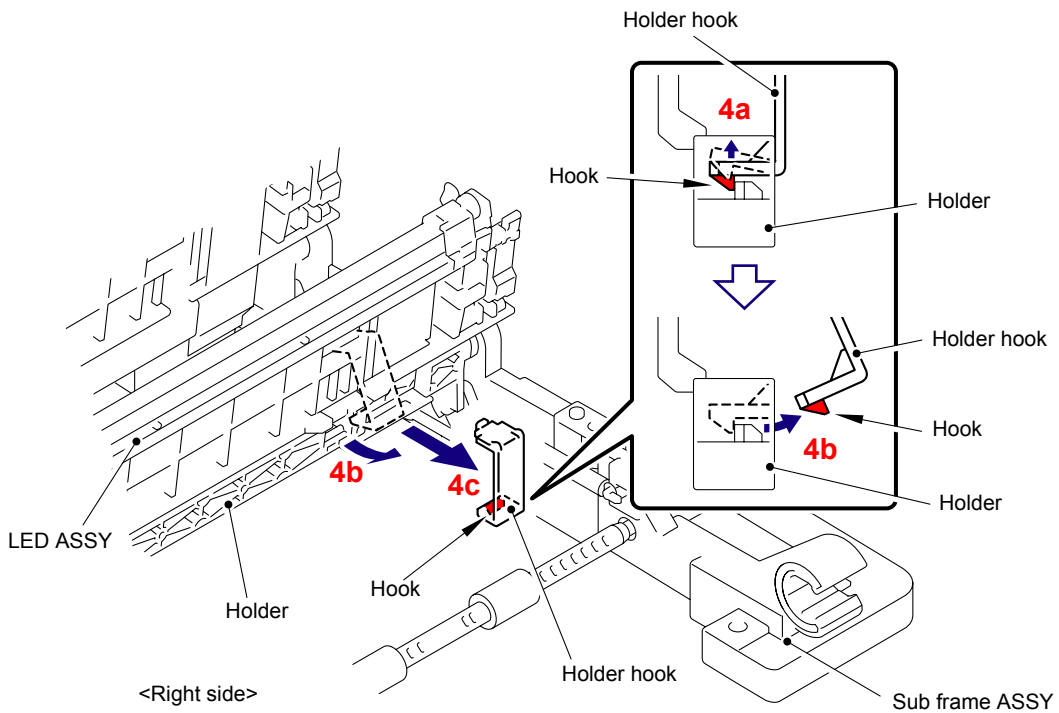
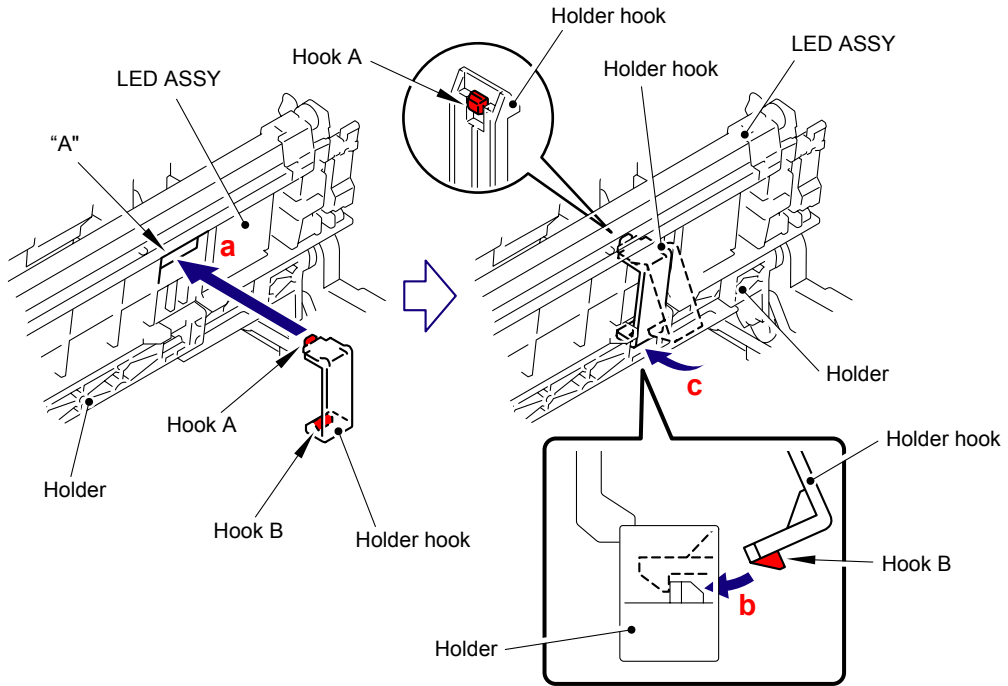

Fig. 5-82

**Assembling Note:**

- When you assemble the Holder hook, make sure to insert the Hook A of the Holder hook into the "A" of the LED ASSY first, and then assemble the Hook B of the Holder hook to the Holder.
- After assembling, make sure to check that the Hook A is firmly engaged to the Holder. If it is not engaged to the Holder firmly, it might cause an image failure.



**Fig. 5-83**

- (5) Remove the LED ASSY from the Holder.
- (6) Remove the other LED ASSYs in the same way as procedures (3) to (5) above.

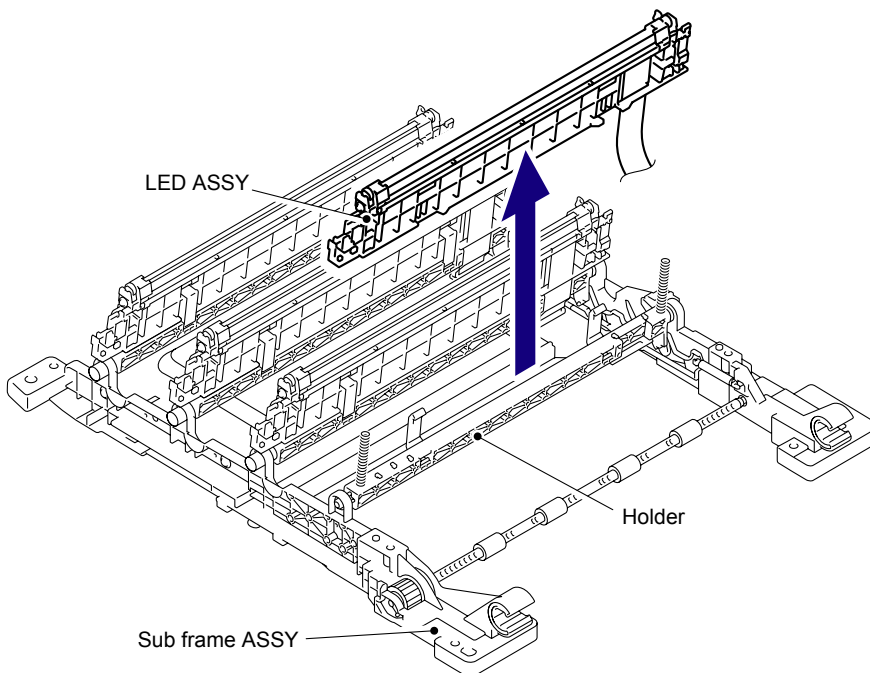

**Fig. 5-84**

**Assembling Note:**

- The LED parts of the LED ASSY for replacement are covered with protection tapes. Make sure not to remove the protection tapes until assembling of the LED ASSY is completed. After it is assembled, make sure to remove the protection tapes.
- If the LED parts get smeared, make sure to wipe smears on the LED parts with a clean and soft cloth.

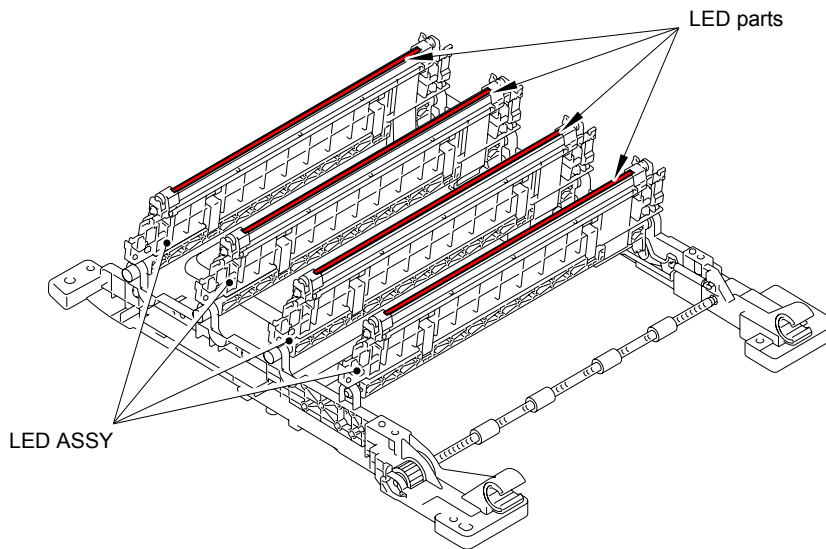

**Fig. 5-85**

**Assembling Note:**

Since folding part of FFC sheet is different according to color of LED, make sure to fold FFC sheet as shown in Fig. 5-86 and Fig. 5-87 before assembling LED ASSY.

<LED ASSY side>

There are lines on the side of LED ASSY of the FFC sheet. Make to fold FFC sheet along the line in order to replace LED ASSY correctly.

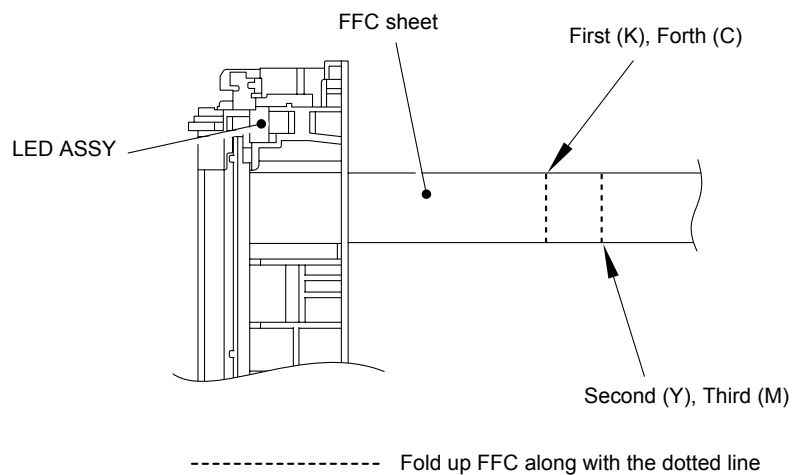

**Fig. 5-86**

<LED head control PCB ASSY side> (full-scale)

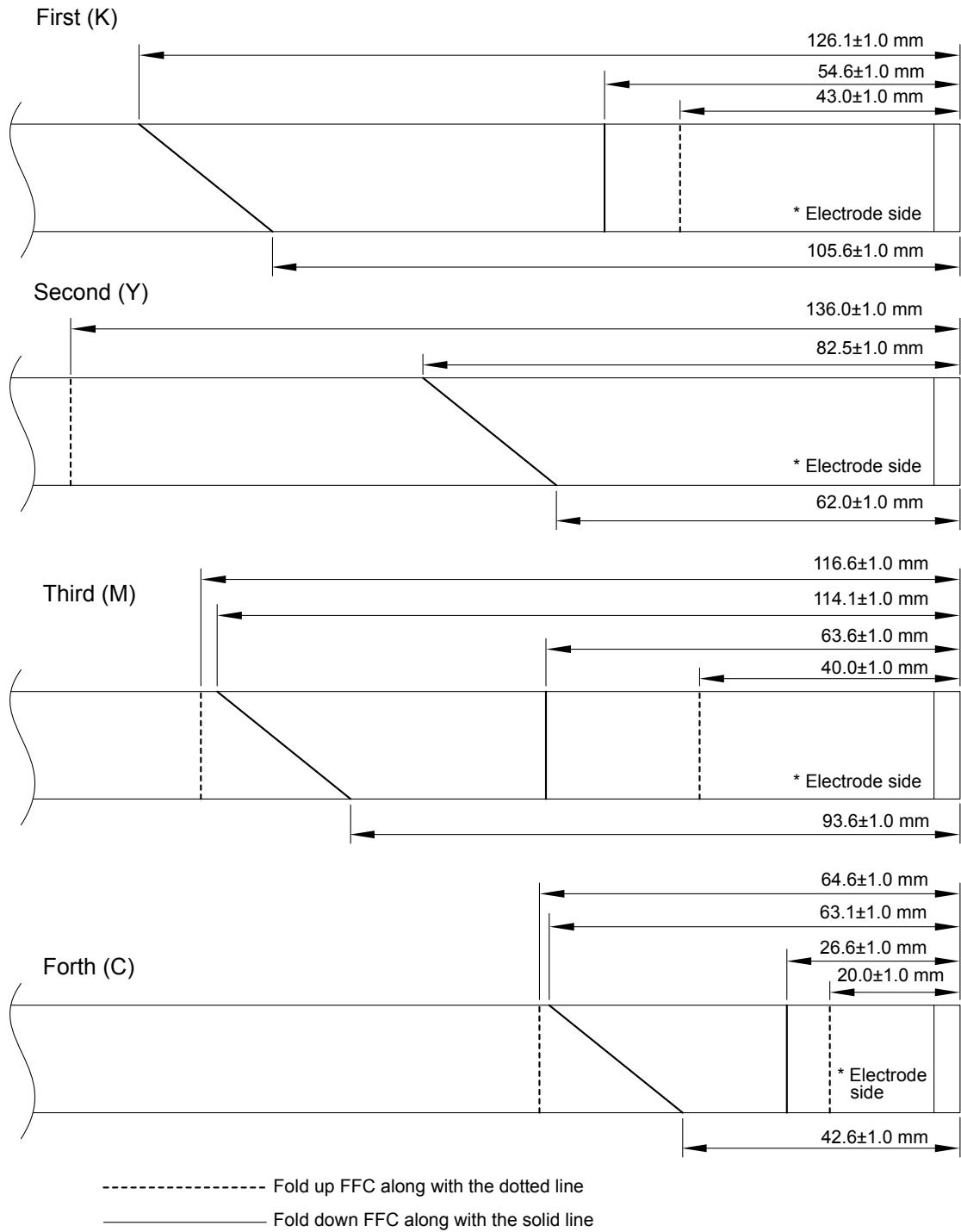

Fig. 5-87

# 8.27 Z Spring L/Z Spring R

(1) Remove the Z spring L from the Holder of the Sub frame ASSY.

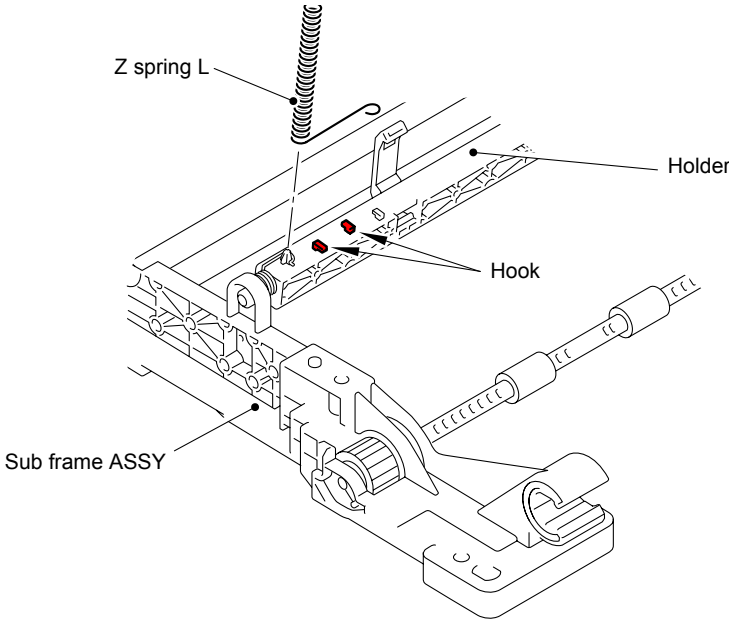

Fig. 5-88

**Assembling Note:**  
When mounting the Z spring L, make sure to assemble them as shown in the figure below.

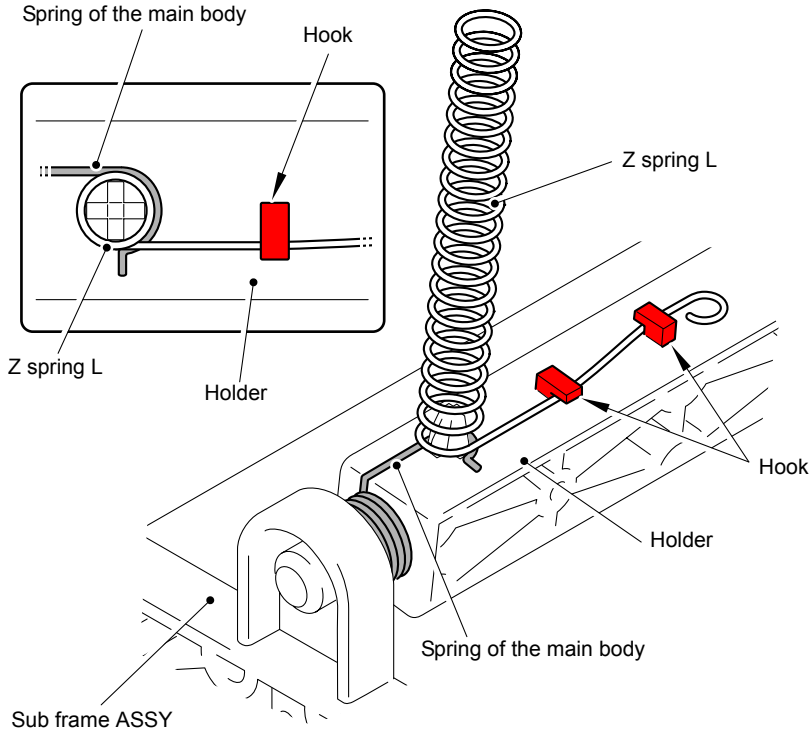
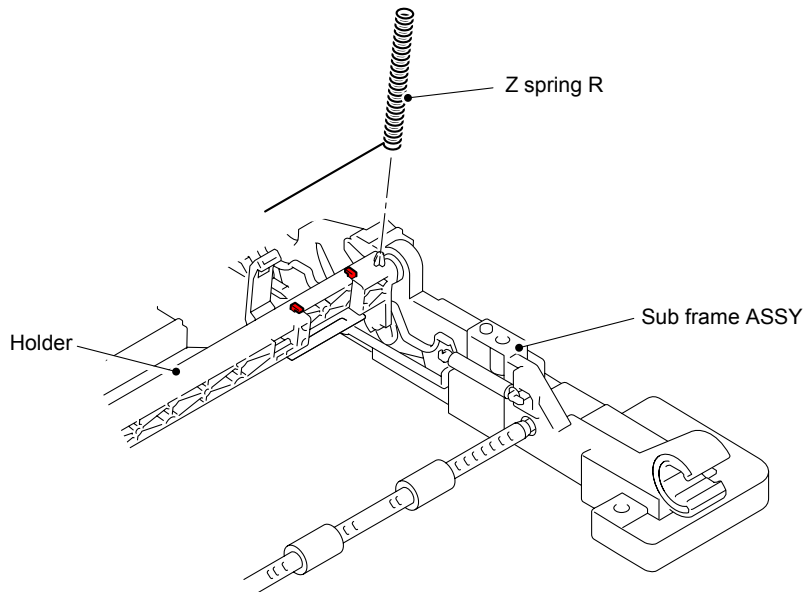

Fig. 5-89

- (2) Remove the Z spring R from the Holder of the Sub frame ASSY.
- (3) Remove the Z spring L and R from the other three Holders with the aforementioned procedures (1) and (2).



**Fig. 5-90**

**Assembling Note:**

When mounting the Z spring R, make sure to assemble them as shown in the figure below.

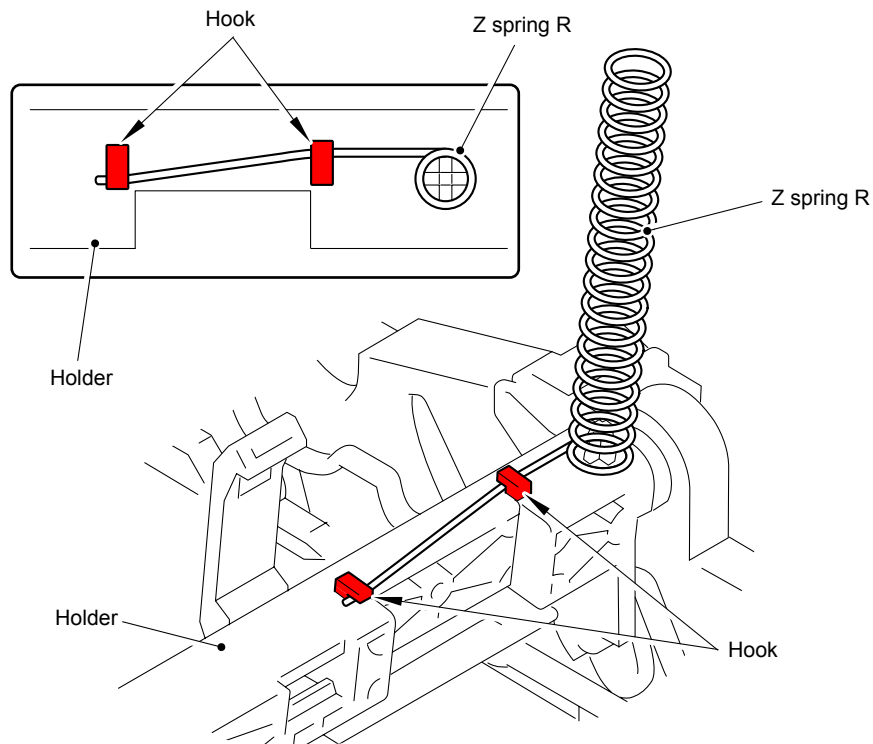

**Fig. 5-91**

## 8.28 Develop Release Motor ASSY

- (1) Disconnect the Connector (CN5) from the Engine PCB ASSY.

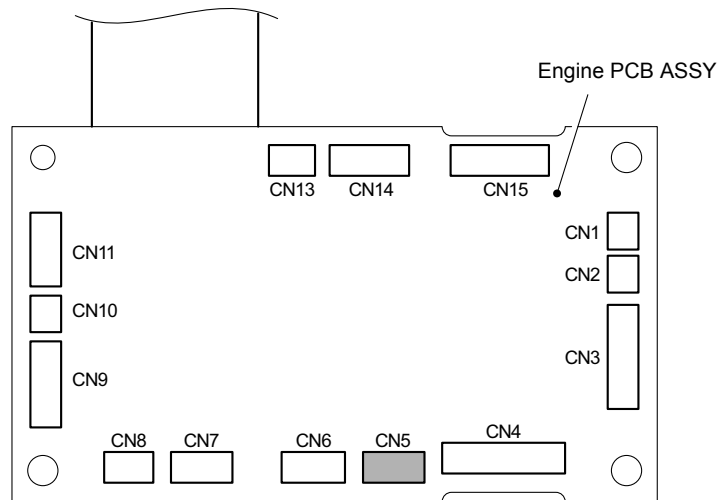

Fig. 5-92

- (2) Remove the Taptite bind S M3x5 screw, and then remove the Develop release motor ASSY from the Side frame L.

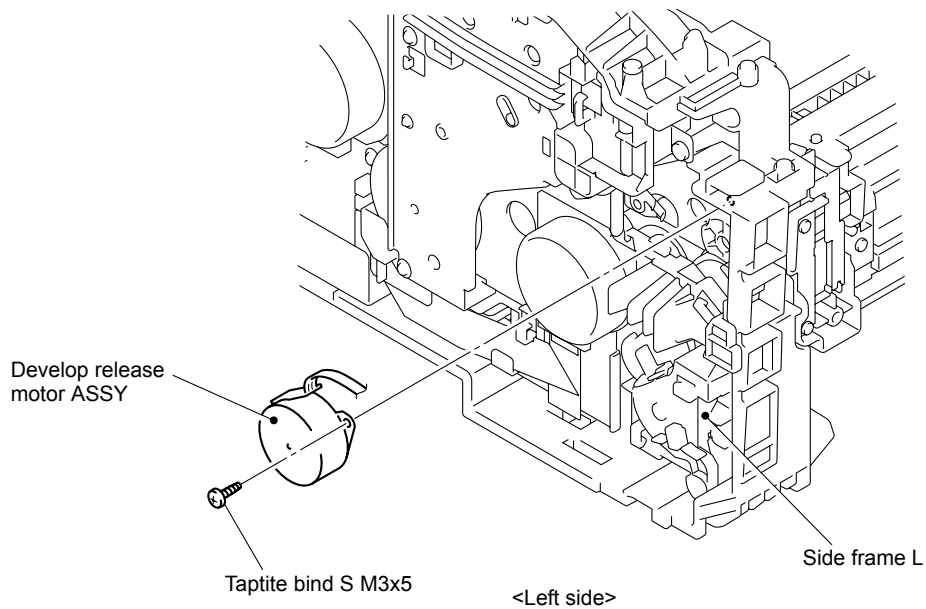
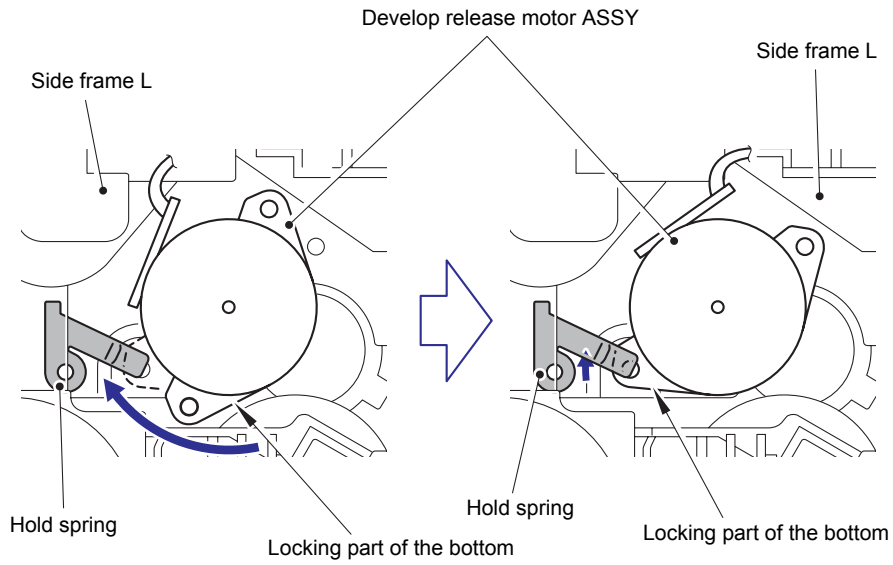

Fig. 5-93

**Harness routing:** Refer to "[6 Develop Release Motor ASSY.](#)"

**Assembling Note:**

- Make sure that the locking part of the Develop release motor ASSY is slid under the Hold spring.
- When assembling the Develop release motor ASSY, make sure to tighten the screw after rotating the Develop release motor ASSY until it stops rotating in the direction indicated by the arrow.



**Fig. 5-94**



## 8.29 Main PCB ASSY

- (1) Disconnect the five Connectors (CN9, CN10, CN11, CN12, CN13) and one flat cable (CN5) from the Main PCB ASSY.

**Note:**

- After disconnecting the flat cable(s), check that each cable is not damaged at its end or short-circuited.
- When connecting the flat cable(s), do not insert it at an angle. After insertion, check that the cable is not at an angle.

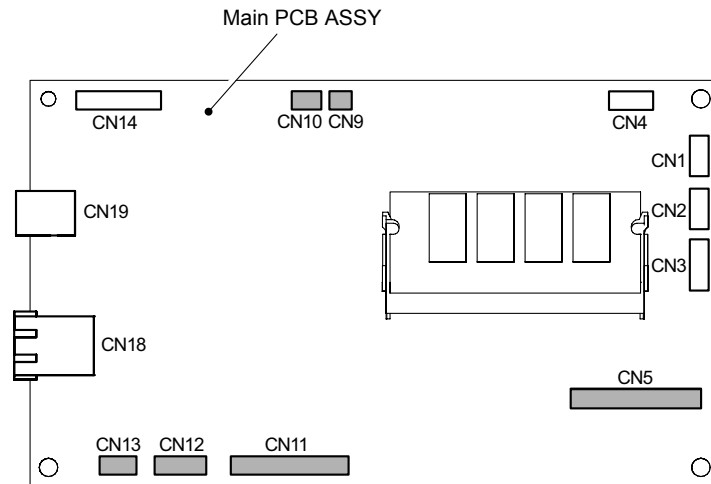

Fig. 5-95

- (2) Remove the four Taptite cup S M3x6 SR screws, and then remove the Main PCB ASSY from the Main PCB shield plate.

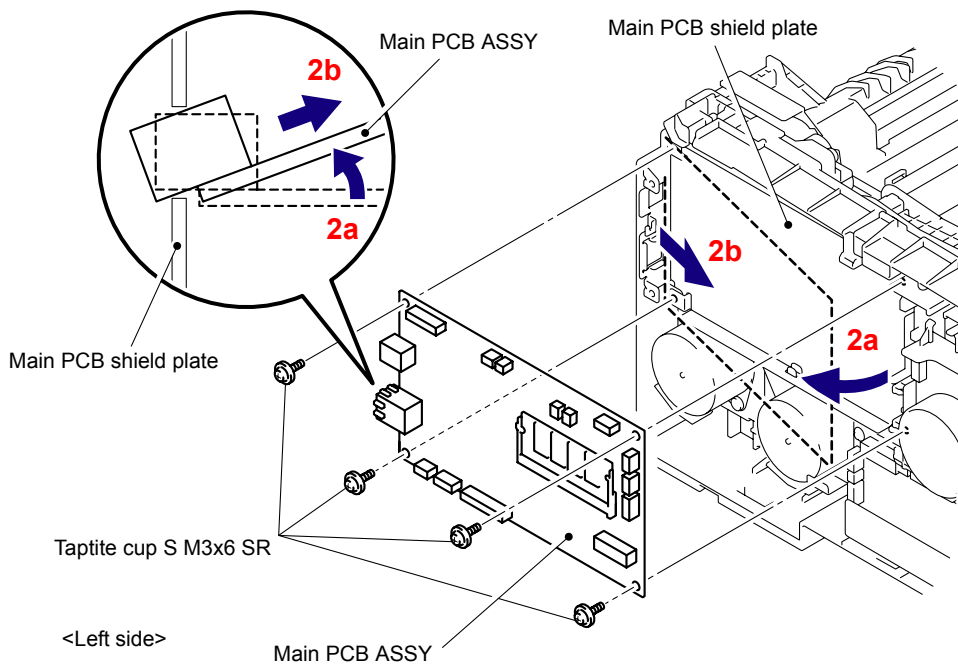

Fig. 5-96

## 8.30 Engine PCB ASSY

- (1) Disconnect the eleven connectors (CN1, CN2, CN4, CN6, CN7, CN8, CN9, CN10, CN11, CN14, CN15) and one flat cable (CN3) from the Engine PCB ASSY.

**Note:**

- After disconnecting the flat cable(s), check that each cable is not damaged at its end or short-circuited.
- When connecting the flat cable(s), do not insert it at an angle. After insertion, check that the cable is not at an angle.

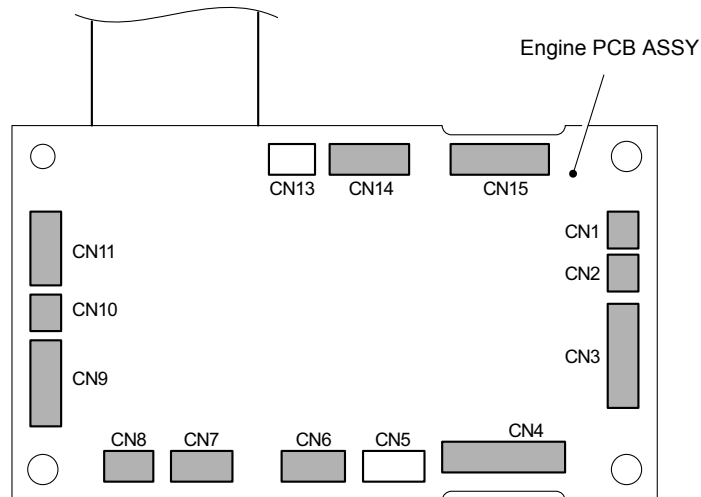

**Fig. 5-97**

- (2) Remove the four Taptite cup S M3x6 SR screws, and then remove the Engine PCB ASSY from the Side frame L.

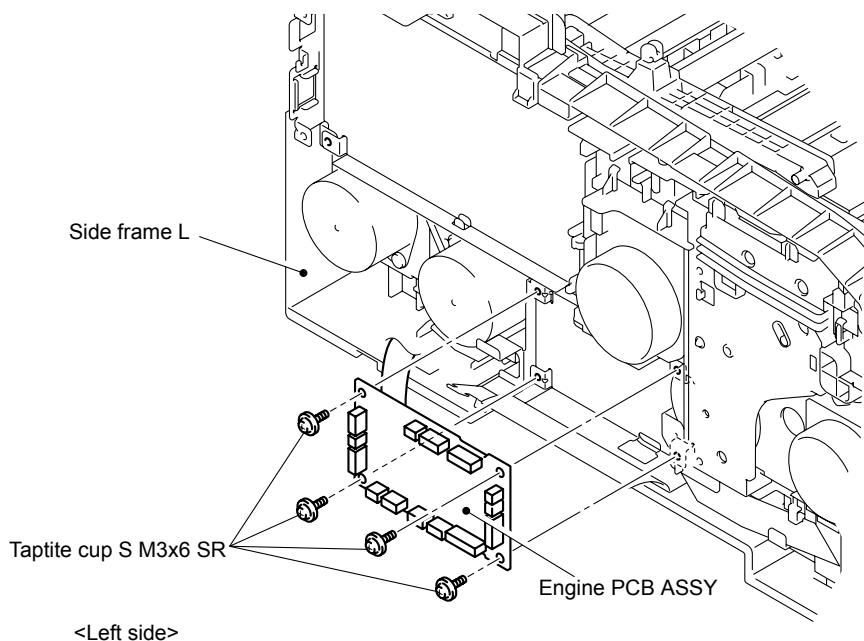

**Fig. 5-98**

# 8.31 Main PCB Insulation Sheet/Engine Insulation Sheet

(1) Remove the Main PCB insulation sheet from the Main PCB shield plate.

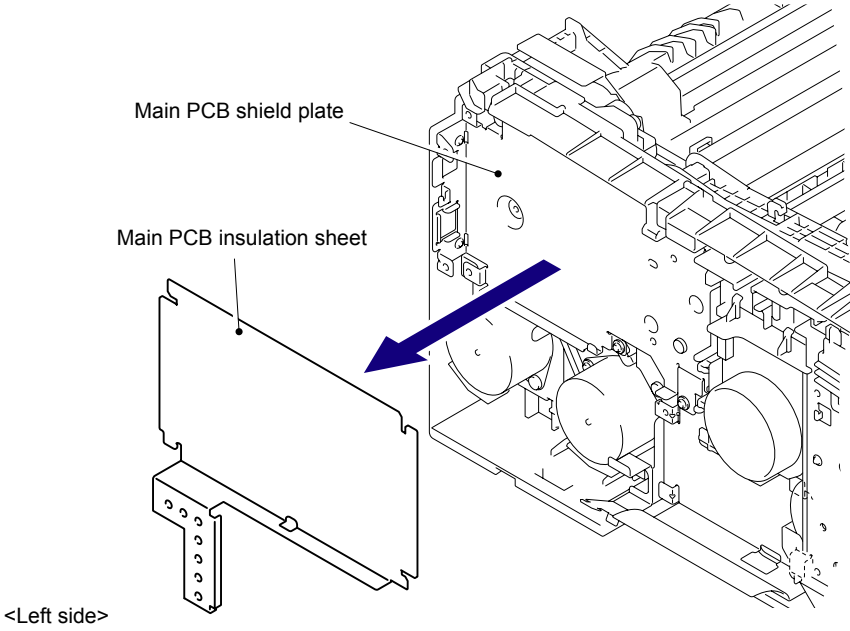

Fig. 5-99

(2) Remove the Engine insulation sheet from the Side frame L.

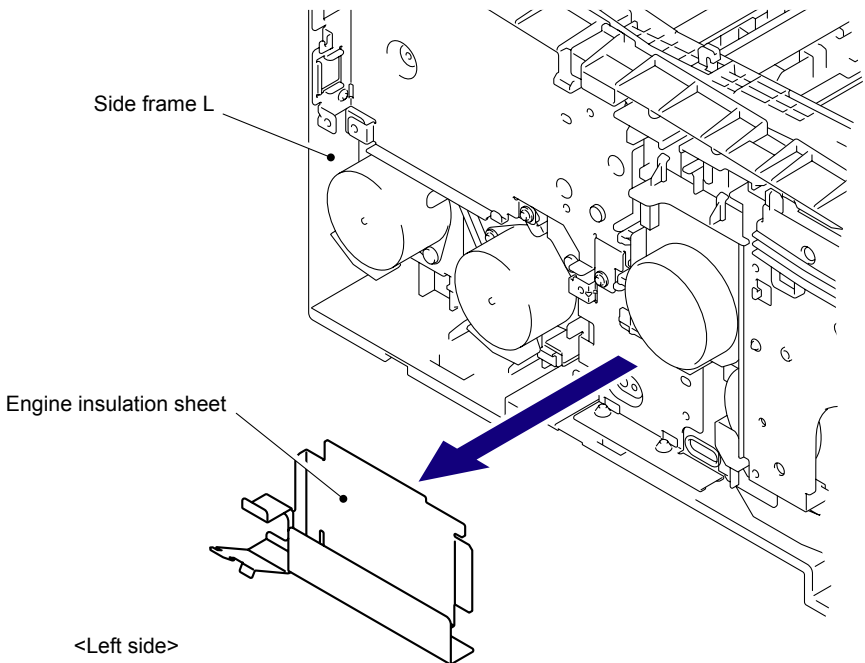

Fig. 5-100

### 8.32 Main PCB Shield Plate

- (1) Remove the three Taptite cup S M3x6 SR screws and one Taptite bind B M4x12 screw, and then remove the Main PCB shield plate from the Side frame L.

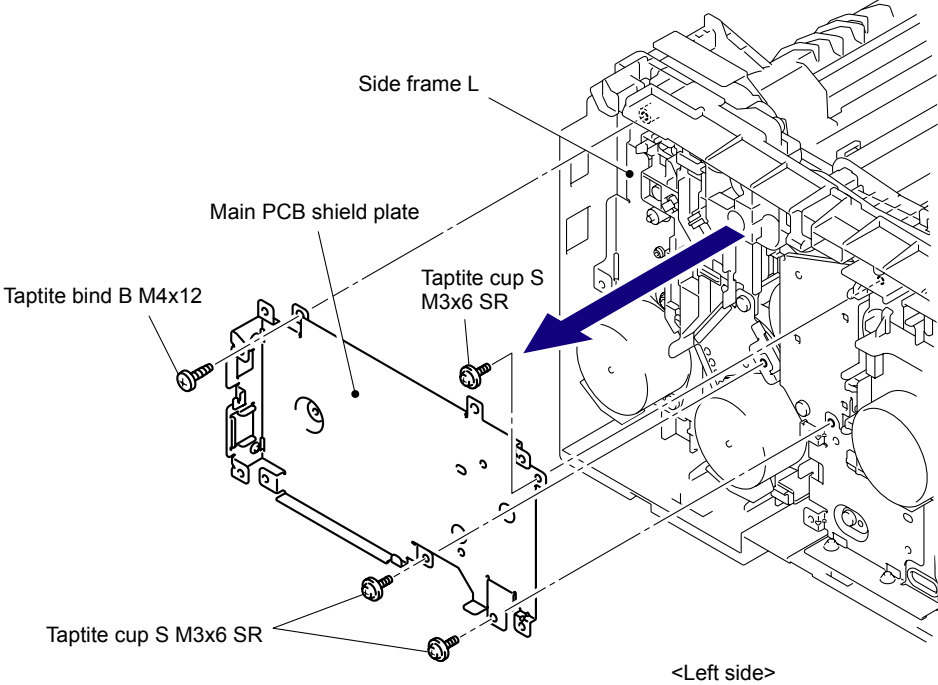

Fig. 5-101

### 8.33 Engine Shield Plate

- (1) Remove the Taptite bind B M4x12 screw and Taptite cup S M3x6 SR screw, and then remove the Engine shield plate from the Side frame L.

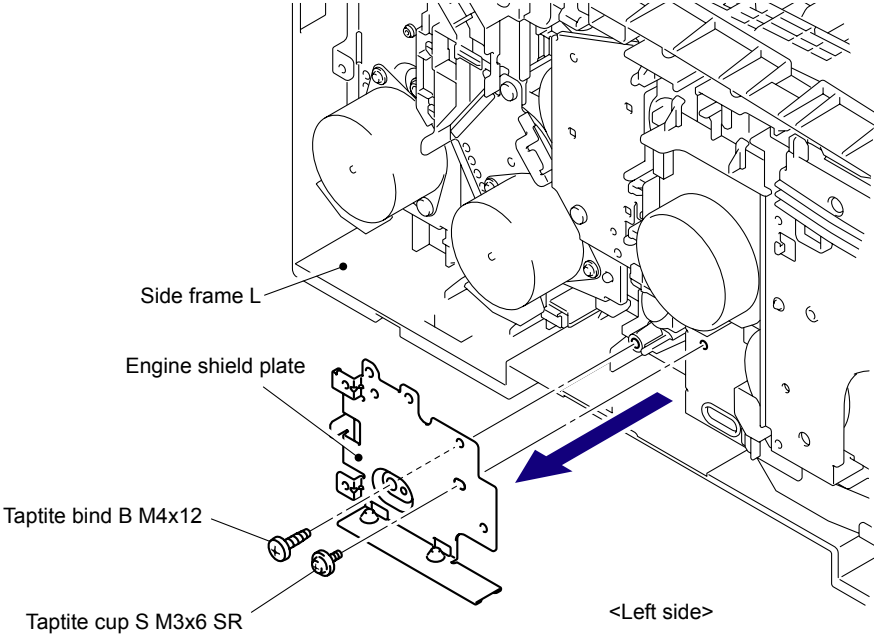

Fig. 5-102

# 8.34 Registration Mark Relay PCB ASSY

- (1) Remove the three Connectors (CN2, CN3, CN4) from the Registration mark relay PCB ASSY.

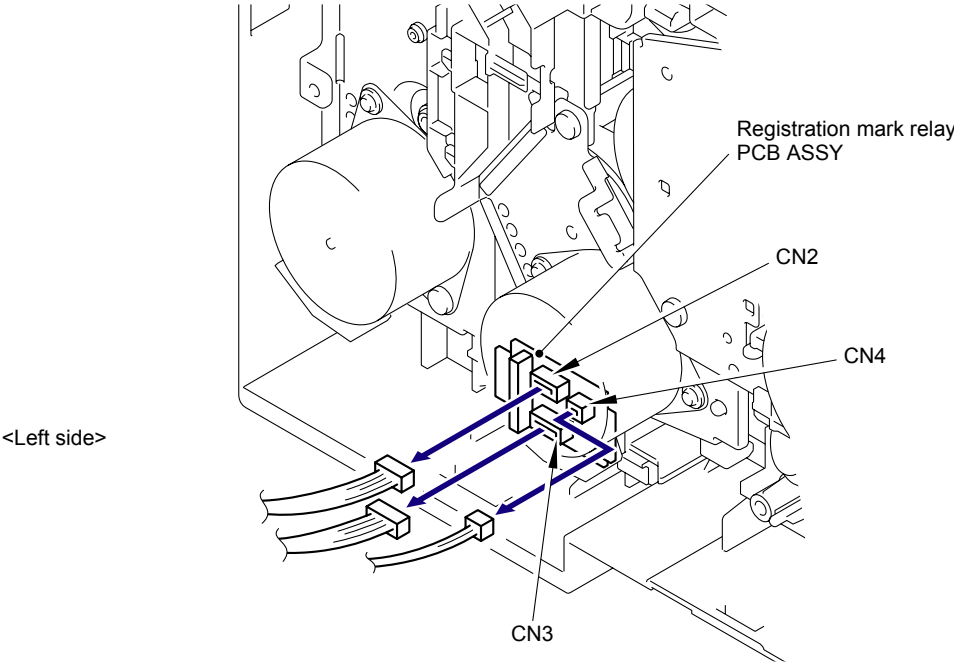

Fig. 5-103

- (2) Release the two Hooks to remove the Registration mark relay PCB ASSY from the Side frame L.

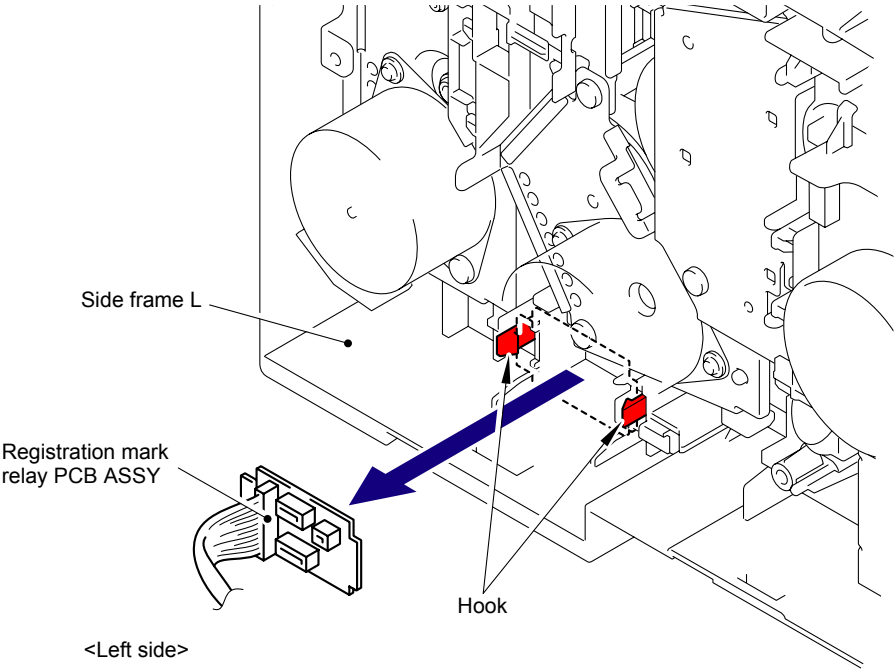

Fig. 5-104

# 8.35 Drum Develop Drive Unit

(1) Place the Main body upright as shown in the figure below.

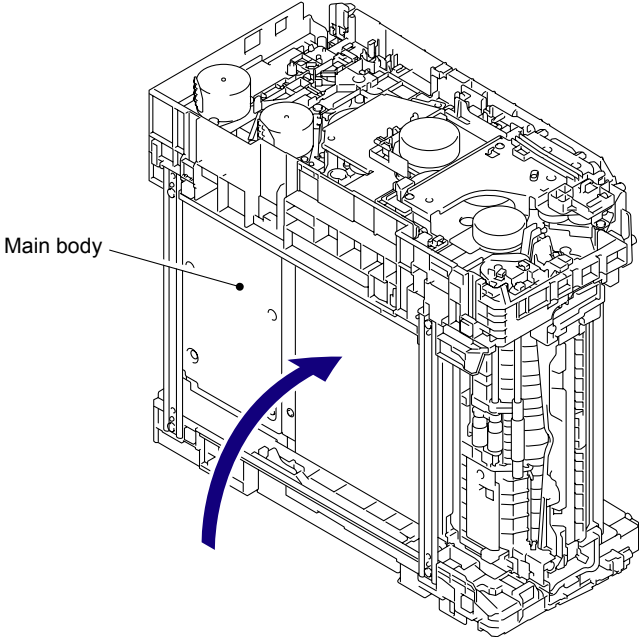

Fig. 5-105

(2) Release the Hook to remove the Line holder front from the Develop drive plate ASSY.

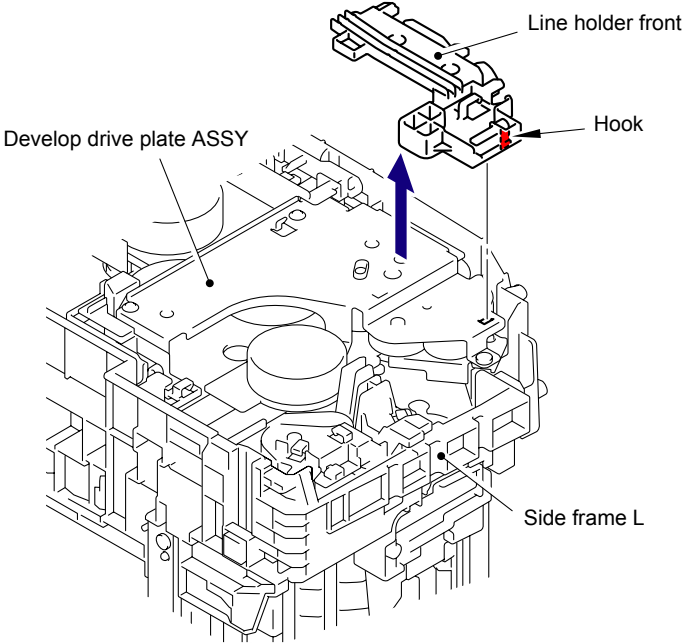
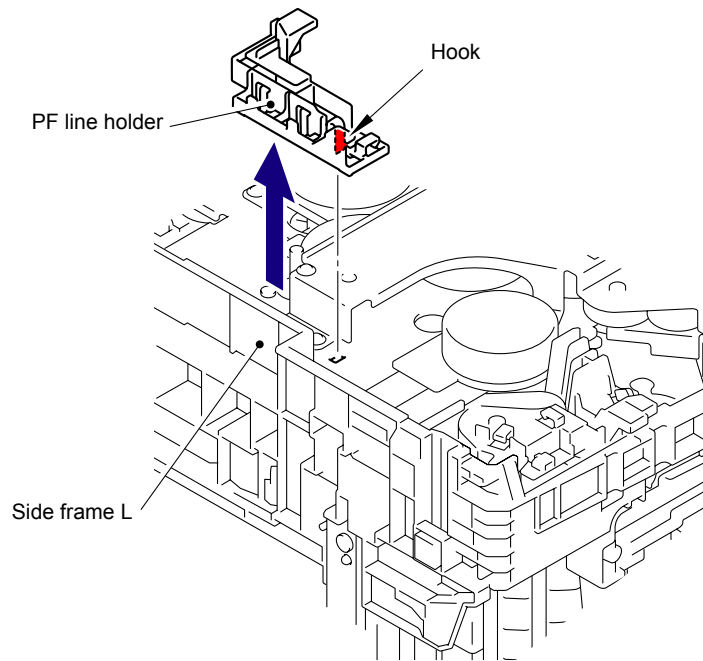

Fig. 5-106

- (3) Release the Hook to remove the PF line holder from the Side frame L.



**Fig. 5-107**

- (4) Release the two Hooks A on the upper side to remove the Line holder M from the Drum develop drive unit.

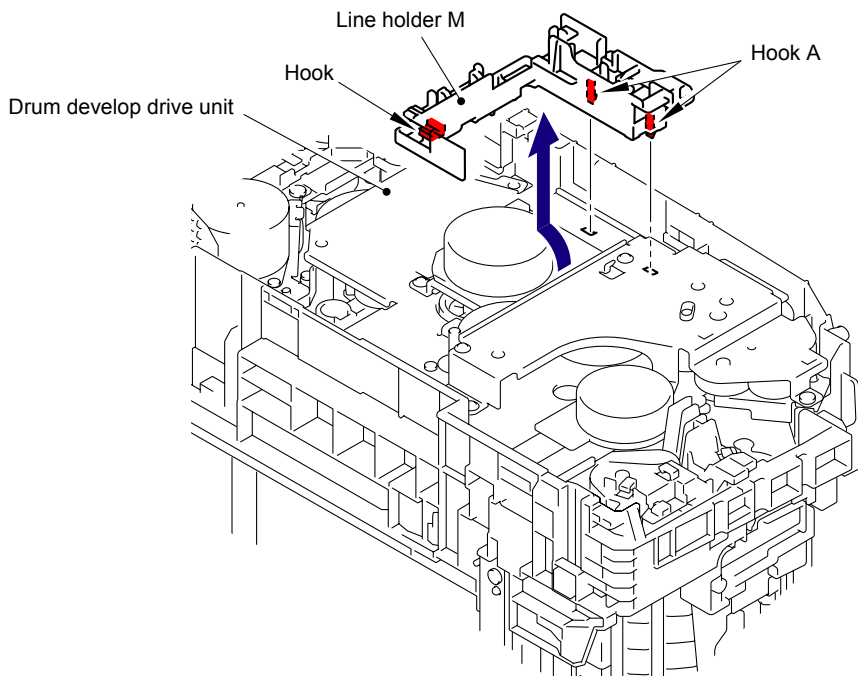

**Fig. 5-108**



- (5) Remove the two Taptite cup S M3x6 SR screws and two Taptite bind B M4x12 screws, and then remove the Develop drive plate ASSY from the Side frame L.

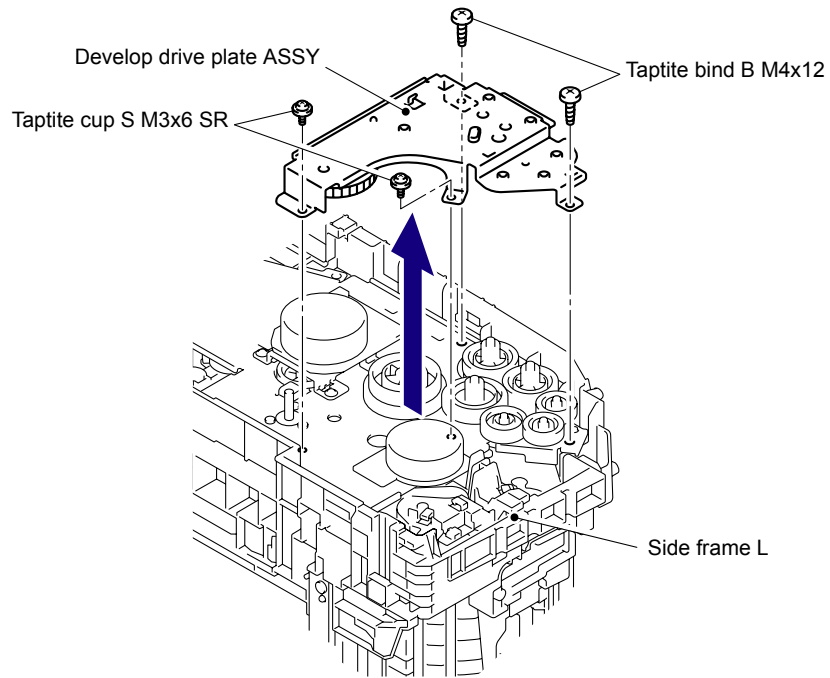

**Fig. 5-109**

- (6) Remove the one Gear 63/85, one Pendulum gear 50, one Idle gear 35, two Idle gear 30 and two Gear 42/39 from the Side frame L.

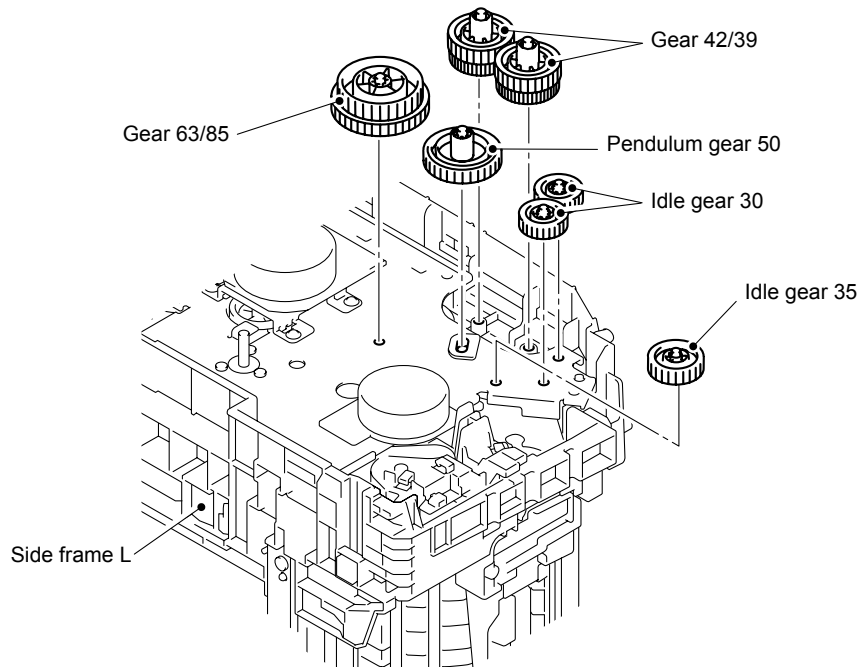

**Fig. 5-110**

- (7) Remove the two Taptite bind B M4x12 screws, and then remove the Under bar from the Main body.

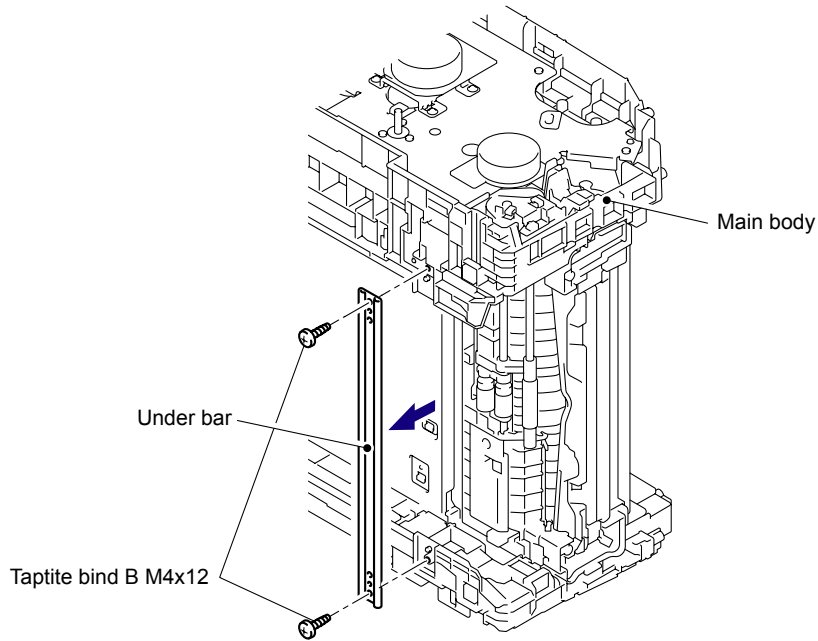

**Fig. 5-111**

- (8) Remove the Taptite cup S M3x6 SR screw, and then remove the Under bar earth plate from the Drum develop drive unit.

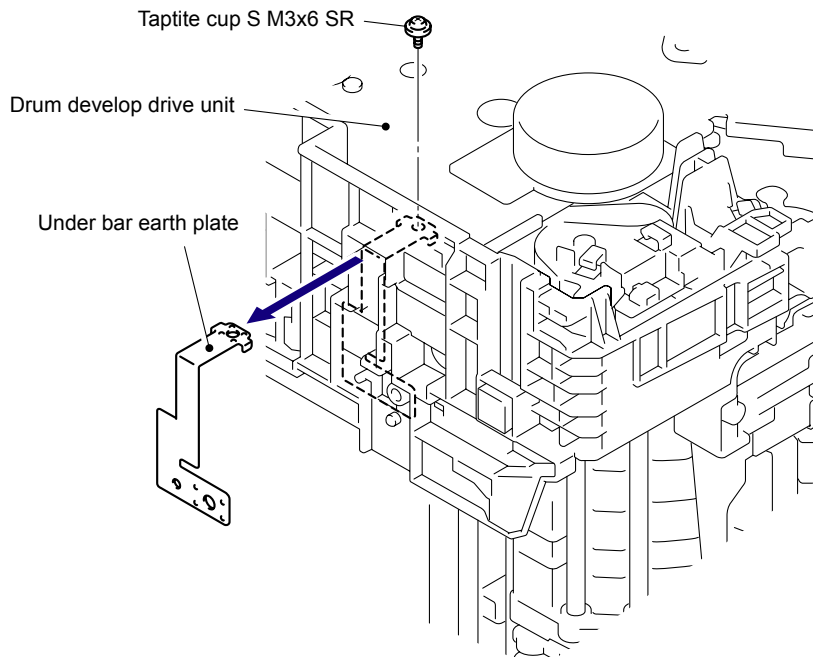

**Fig. 5-112**

- (9) Remove the three Taptite bind B M4x12 screws and two Taptite cup S M3x6 SR screws, and then remove the Drum develop drive unit from the Side frame L.

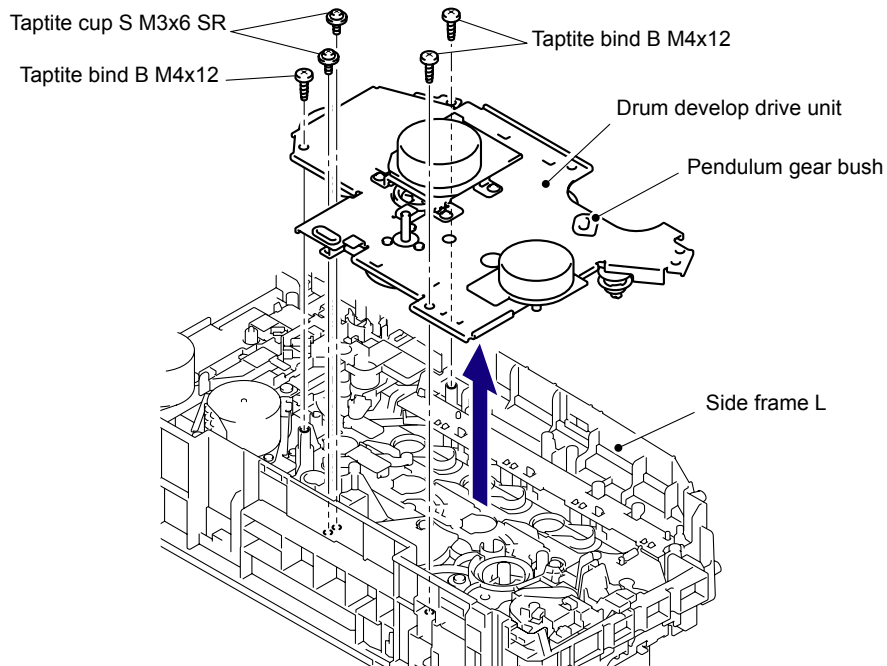

Fig. 5-113

**Harness routing:** Refer to "10 Paper Feed Motor ASSY, Drum Drive Motor."

- (10) Remove the Pendulum gear bush from the Drum develop drive unit.

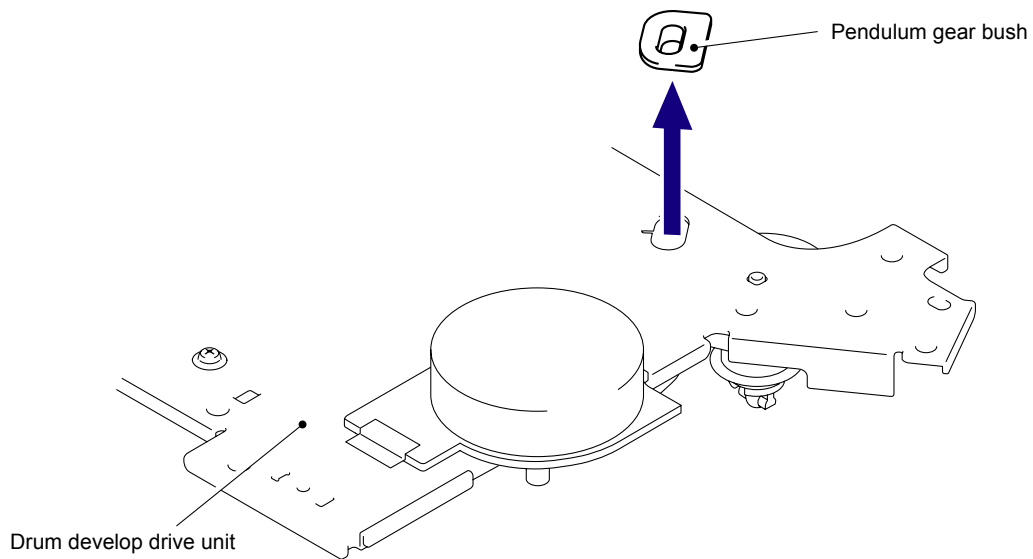

Fig. 5-114

# 8.36 Develop Drive Motor

- (1) Remove the three Screw bind M3x4, and then remove the Develop drive motor from the Drum develop drive unit.

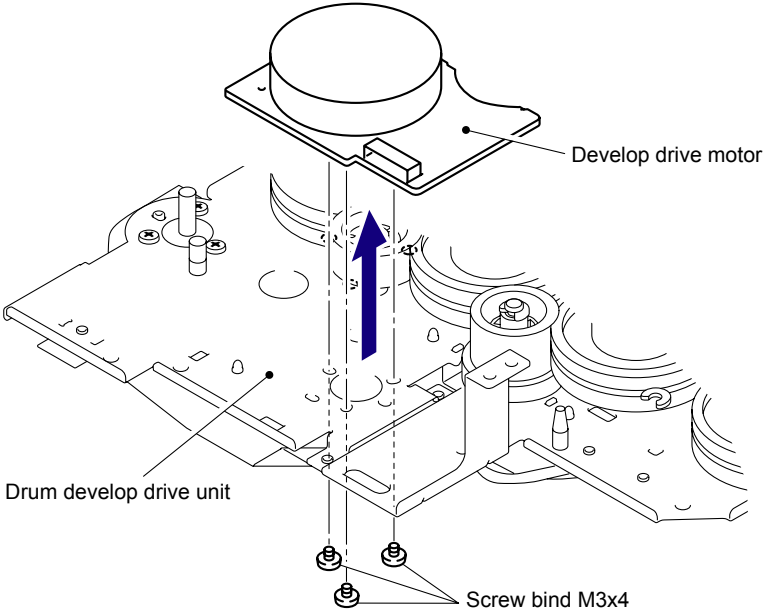

Fig. 5-115

## 8.37 Paper Feed Motor ASSY

- (1) Remove the three Screw bind M3x4, and then remove the Paper feed motor ASSY from the Drum develop drive unit.

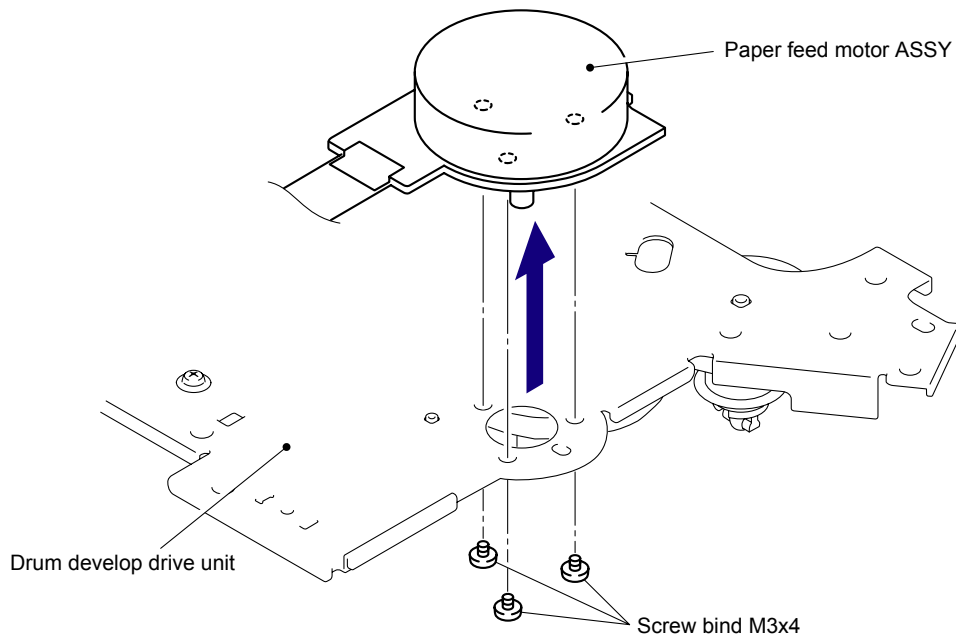

Fig. 5-116

**Harness routing:** Refer to [10 Paper Feed Motor ASSY, Drum Drive Motor.](#)

**Assembling Note:**

When replacing the Paper feed motor ASSY with a new one, fold the FFC first in accordance with the “How to Fold FFC of Paper Feed Motor ASSY” figure in the [next page](#), and then assemble the Paper feed motor ASSY.

<How to Fold FFC of Paper Feed Motor ASSY> (full-scale)

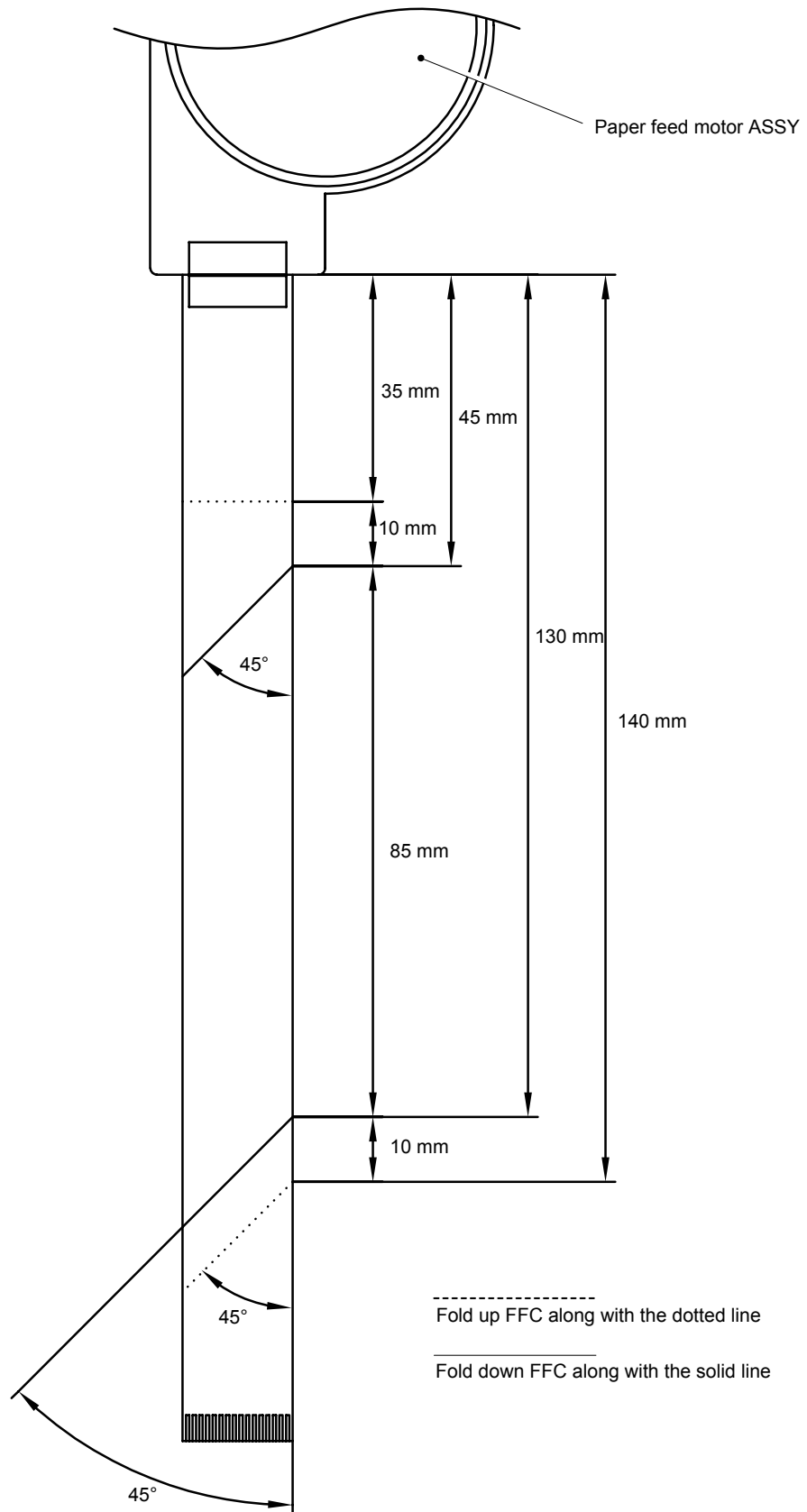

Fig. 5-117

# 8.38 Paper Feed Unit

(1) Remove the Bush cap and Gear 24/28 from the Side frame L.

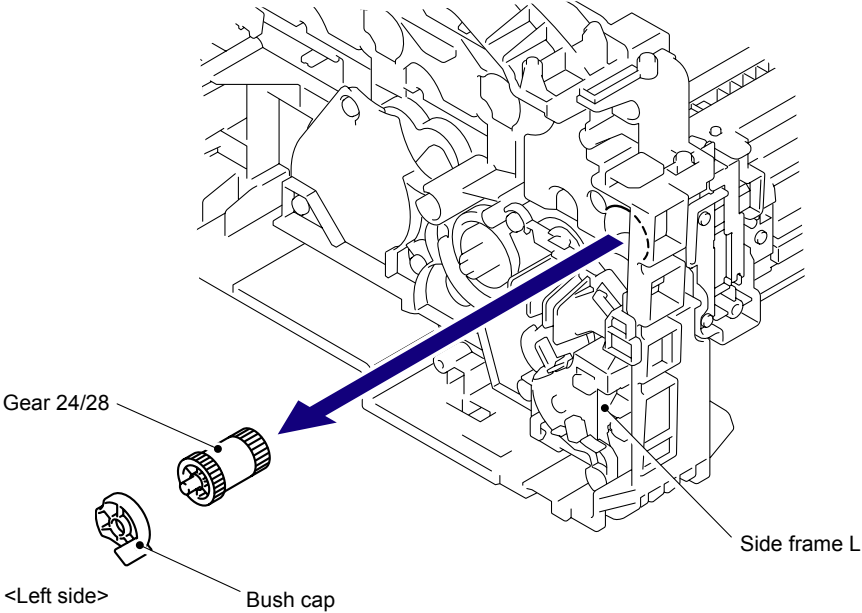

Fig. 5-118

(2) Release the Hook to remove the PF gear cap from the Side frame L.

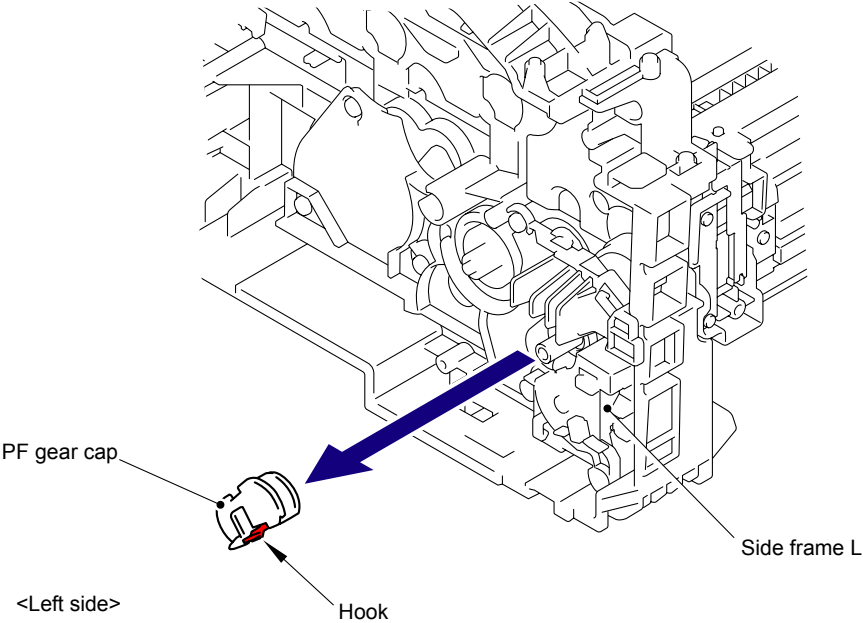
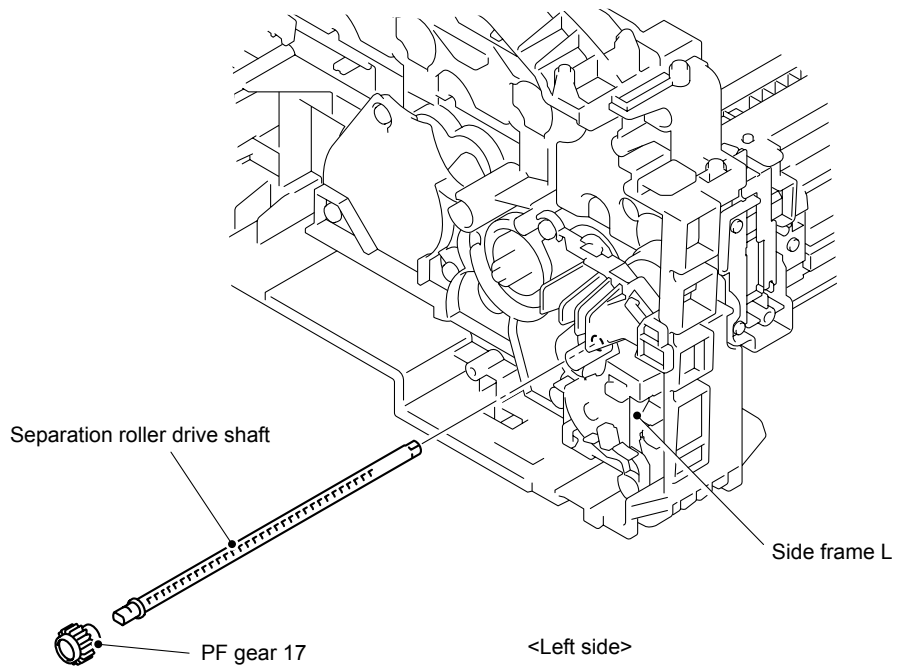

Fig. 5-119

- (3) Remove the PF gear 17 and Separation roller drive shaft from the Side frame L.



**Fig. 5-120**

**Gear position:** Refer to "Cleaner PF."

- (4) Remove the PF drive gear 23 and PF roller drive shaft TR from the Side frame L.

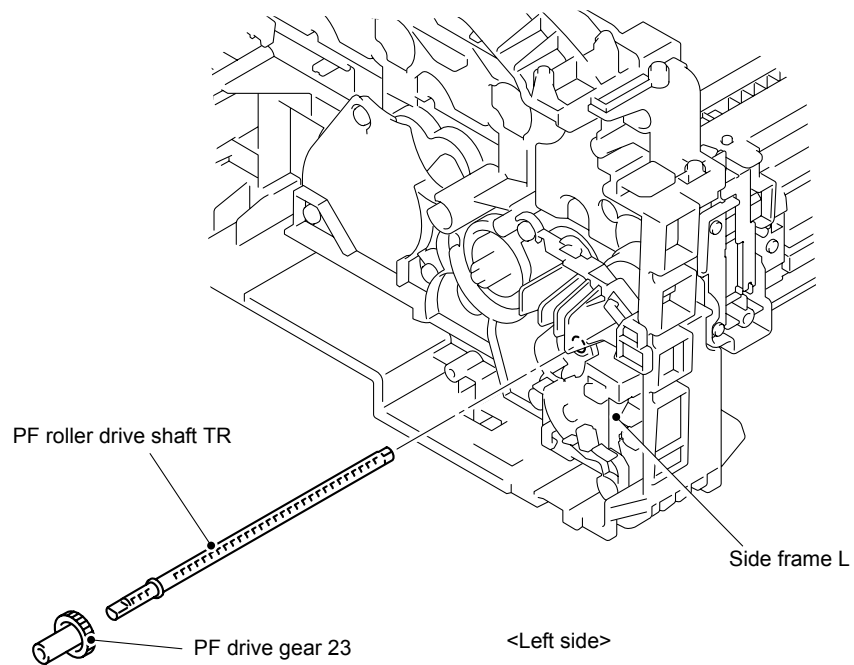

**Fig. 5-121**

**Gear position:** Refer to "Cleaner PF."



- (5) Disconnect the Connector (CN3) of the Registration front/rear sensor harness ASSY from the HVPS control PCB ASSY.

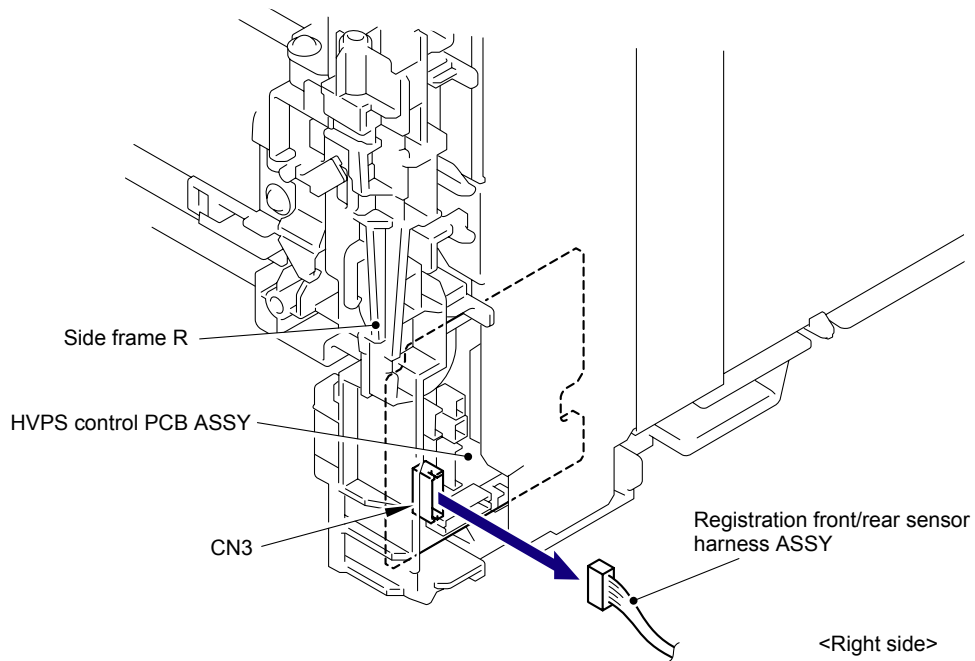

Fig. 5-122

- (6) Remove the three Taptite cup S M3x6 SR screws and two Shoulder screws, and then remove the Paper feed unit from the Main body.

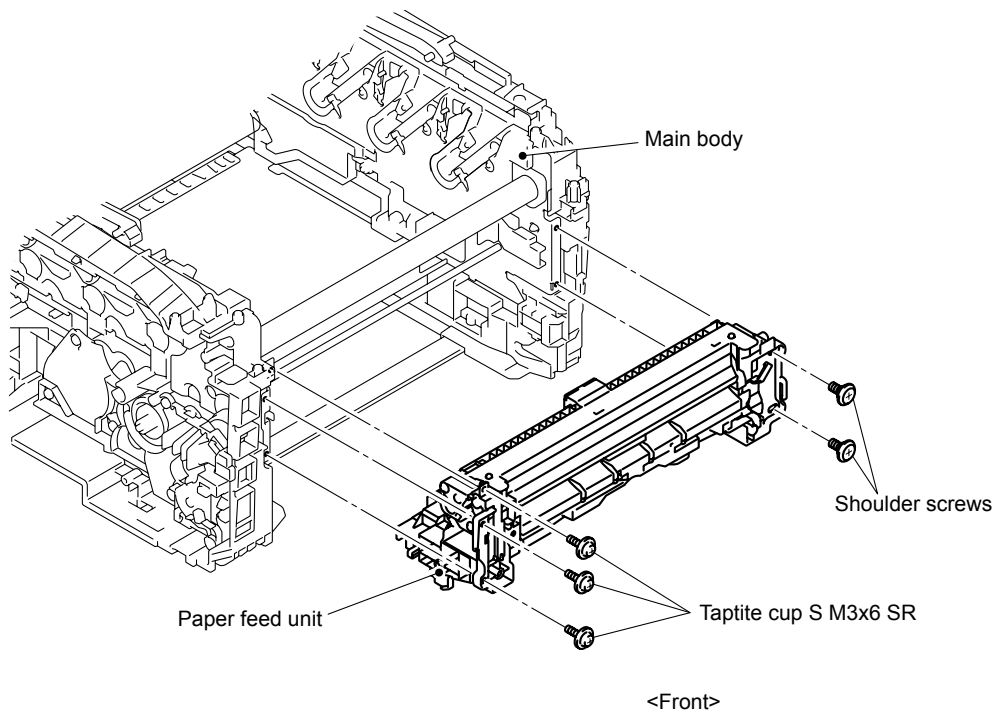

Fig. 5-123

## 8.39 Registration Front/Rear Sensor PCB ASSY

- (1) Remove the two Taptite cup B M3x10 screws from the PF upper cover ASSY.
- (2) Keep the shutter part of the Registration rear actuator at the position shown in the figure below.
- (3) Release the two Bosses to remove the PF upper cover ASSY from the Paper feed unit.

**Note:**

When removing the PF upper cover ASSY, be careful not to damage the Registration rear actuator.

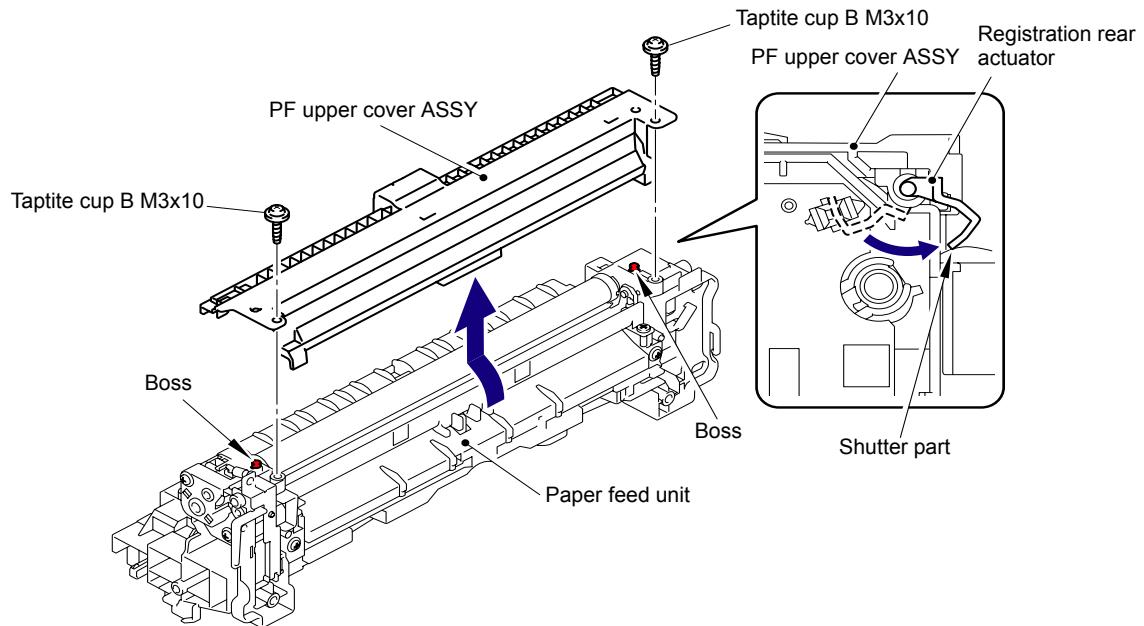

Fig. 5-124

- (4) Disconnect the Connector (CN2) of the Manual sensor harness ASSY from the Registration front/rear sensor PCB ASSY.

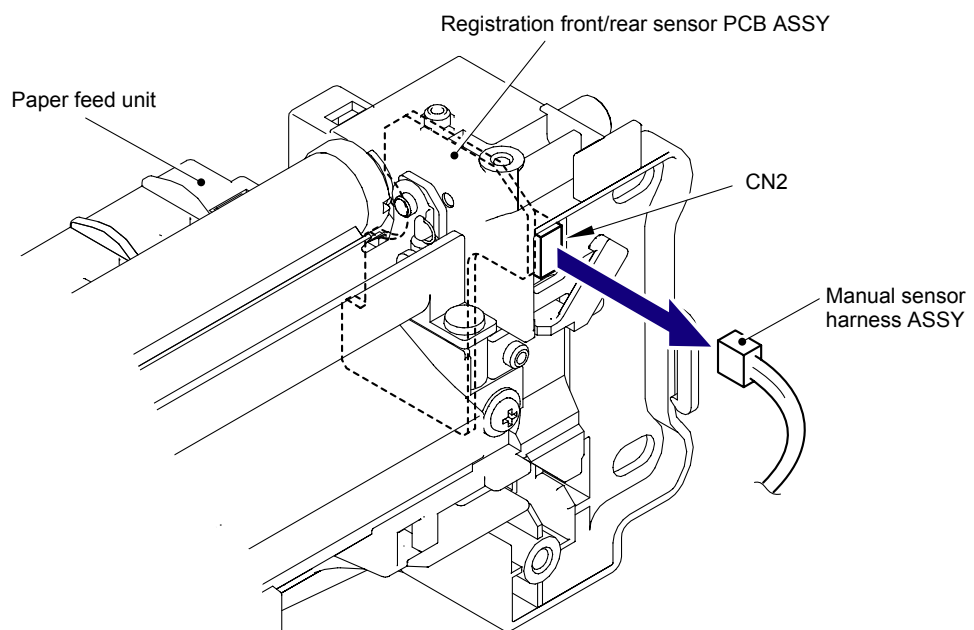
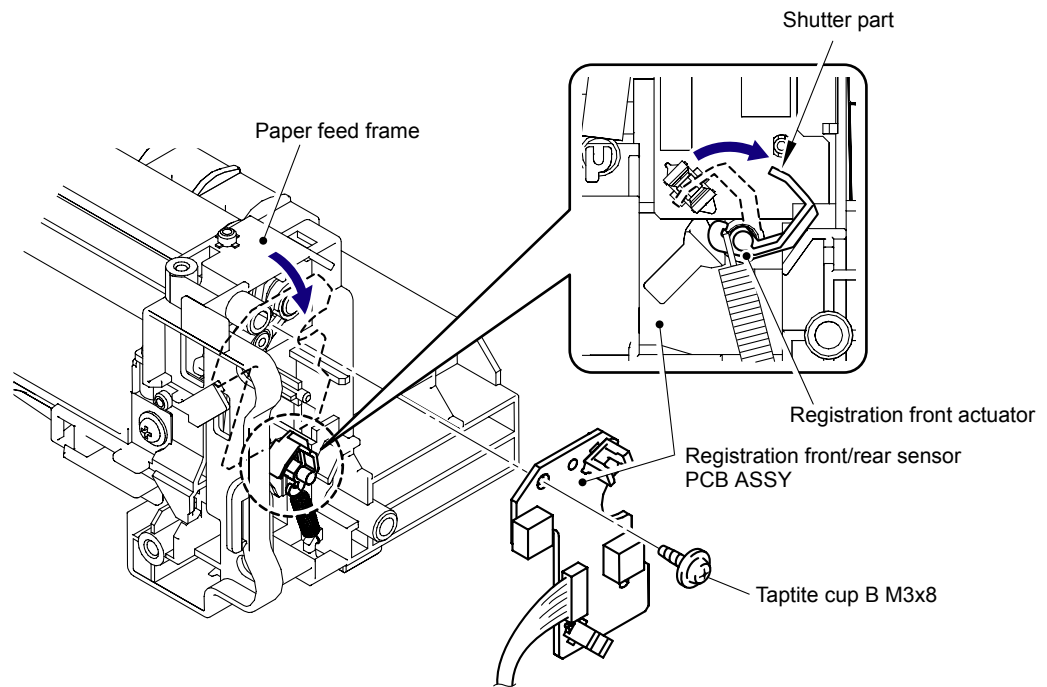

Fig. 5-125

- (5) Remove the Taptite cup B M3x8 screw from the Registration front/rear sensor PCB ASSY.
- (6) Keep the shutter part of the Registration front actuator at the position shown in the figure below.
- (7) Remove the Registration front/rear sensor PCB ASSY from the Paper feed frame.

**Note:**

When removing the Registration front/rear sensor PCB ASSY, be careful not to damage the Registration front actuator.



**Fig. 5-126**

**Harness routing:** Refer to "[2 Registration Front/Rear Sensor PCB ASSY.](#)"

## 8.40 Manual Sensor PCB ASSY

- (1) Remove the two Taptite cup B M3x10 screws, and then remove the Front chute ASSY from the Paper feed unit.

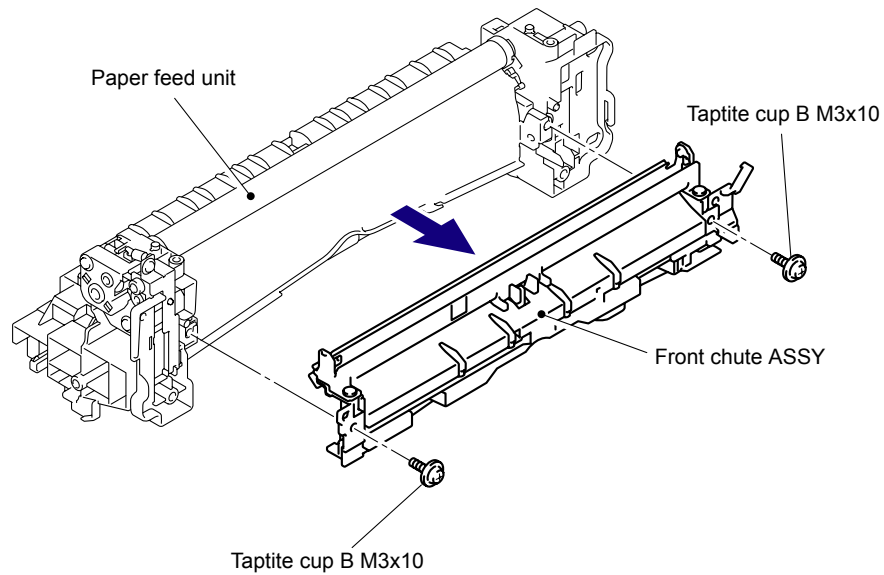

Fig. 5-127

- (2) Release the Hook to remove the Manual sensor PCB ASSY from the Front chute ASSY.

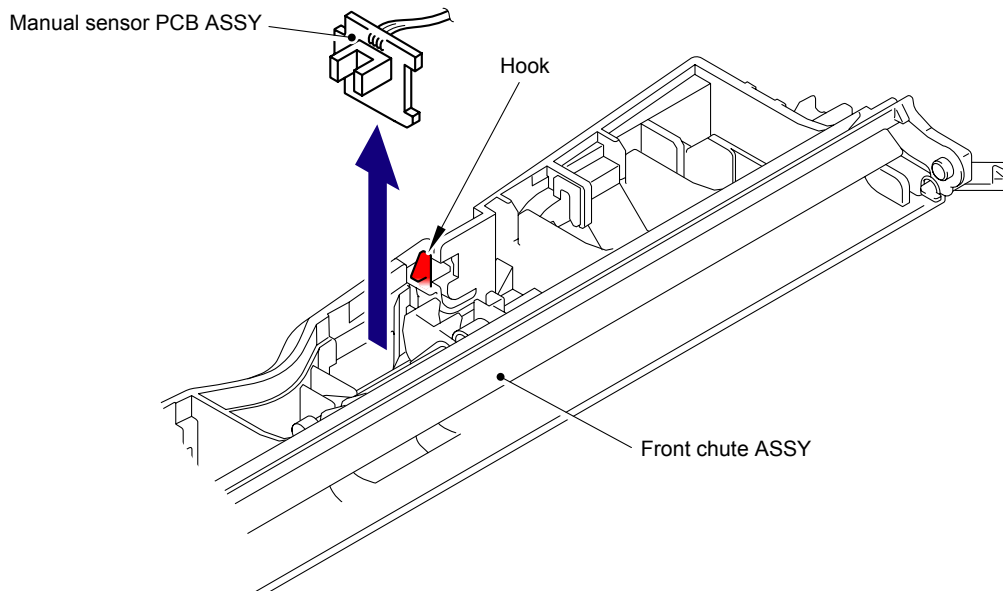

Fig. 5-128

**Harness routing:** Refer to "[3 Manual Sensor PCB ASSY.](#)"

# 8.41 Pick-up Sector Gear Spring/Friction Spring

(1) Remove the Gear 27/72 from the Side frame L.

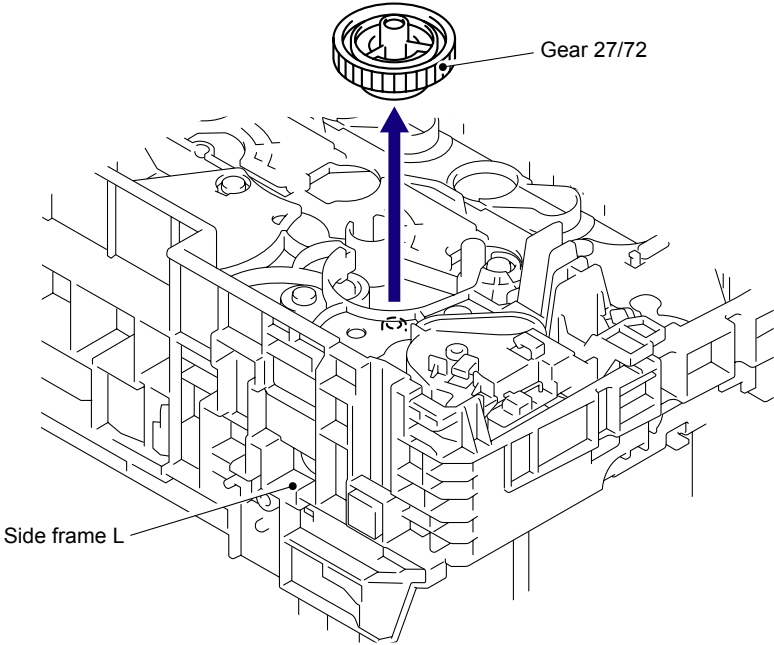

Fig. 5-129

(2) Remove the Pick-up sector gear spring from the Hook of the Cleaner PF gear cover.

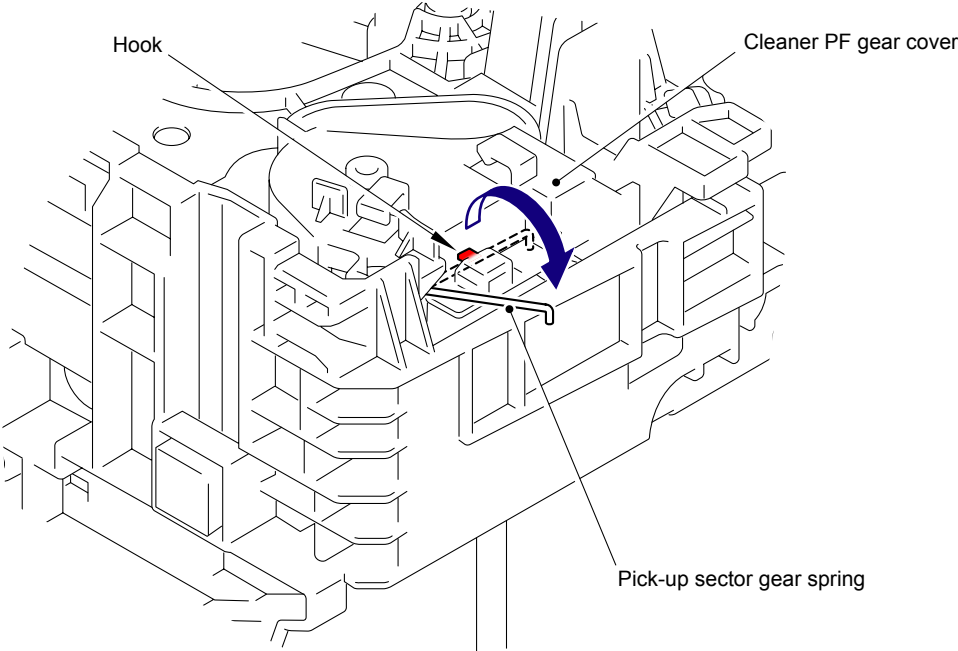

Fig. 5-130

- (3) Remove the five Taptite bind B M4x12 screws, and then remove the Cleaner PF gear cover from the Side frame L.

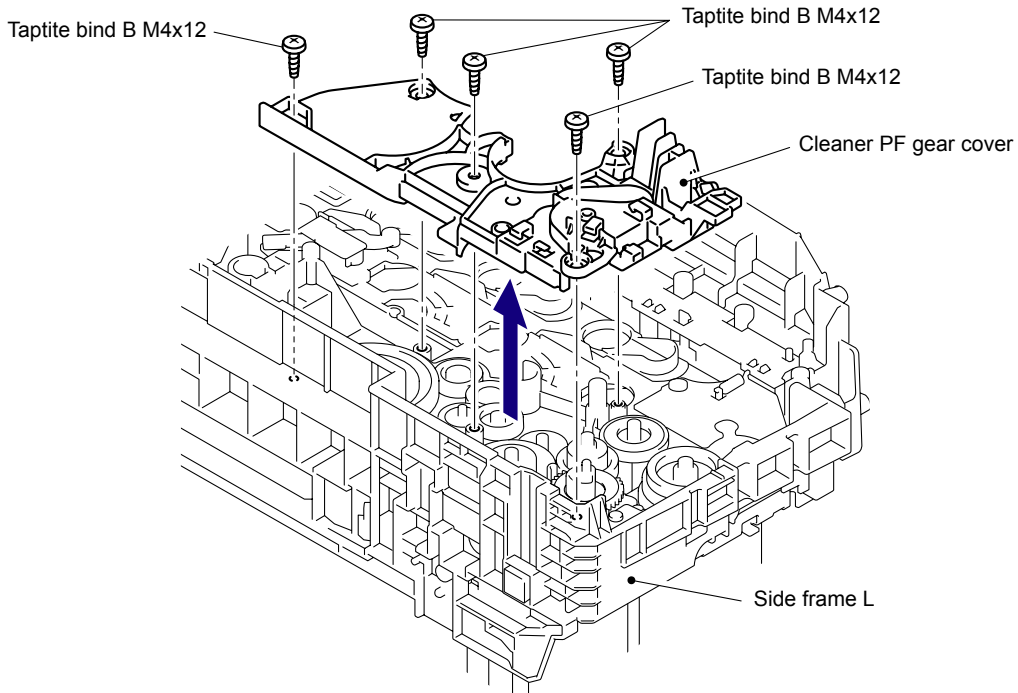

Fig. 5-131

**Assembling Note:**

When assembling the Cleaner PF gear cover, make sure to place the Pick-up sector gear spring and PF registration solenoid harness correctly as shown in the figure below.

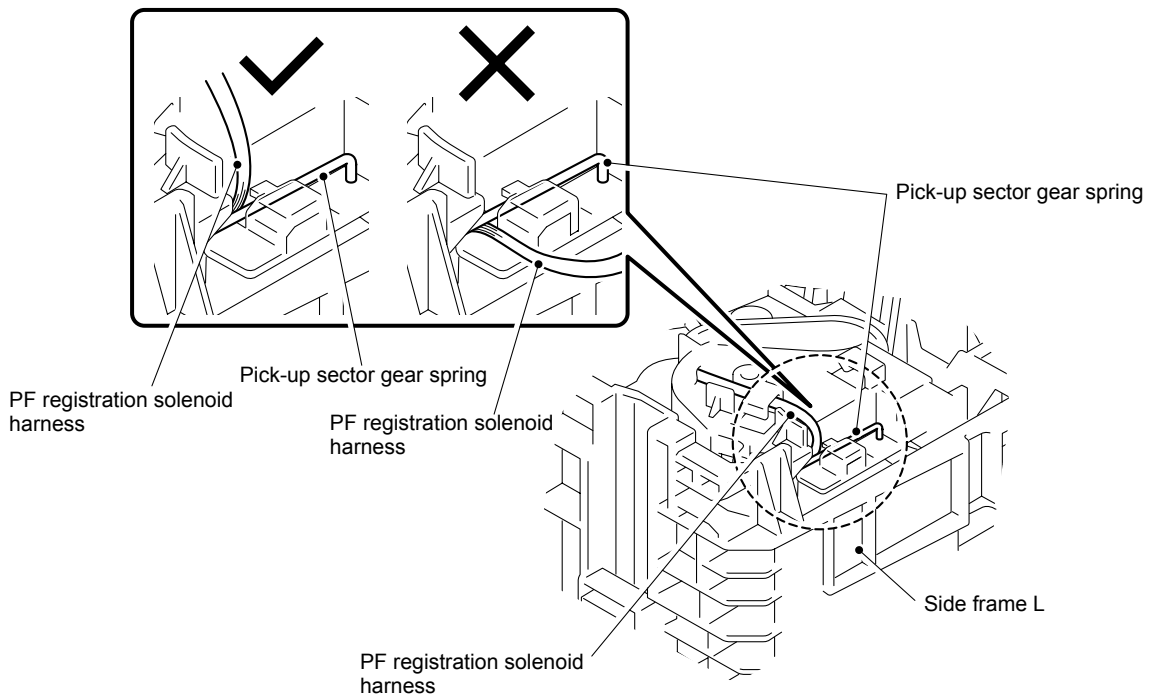
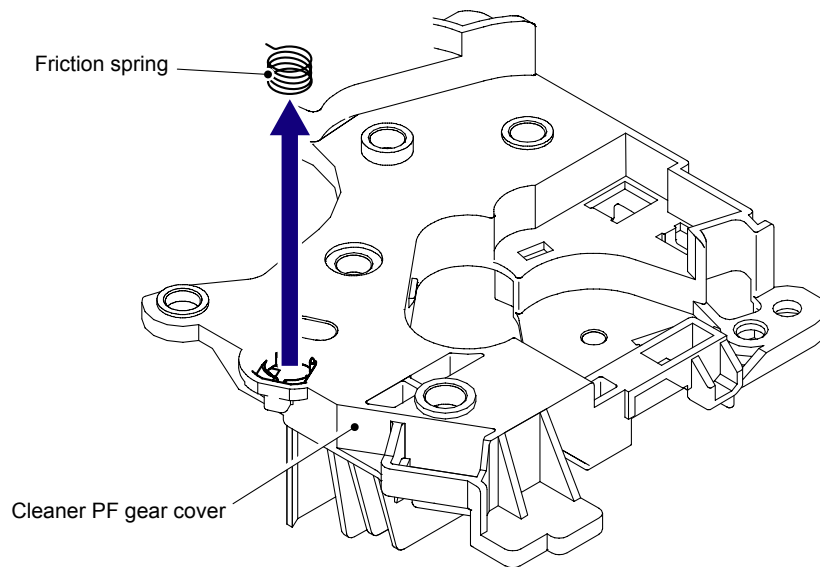

Fig. 5-132

- (4) Remove the Friction spring from the Cleaner PF gear cover.



**Fig. 5-133**

- (5) Remove the Pick-up sector gear spring from the Side frame L.

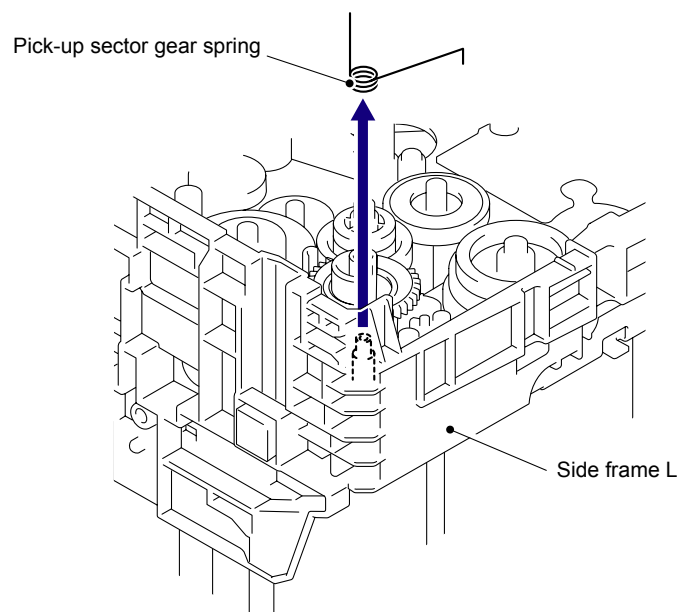

**Fig. 5-134**

# 8.42 PF Registration Solenoid

(1) Remove the Pick-up sector gear 31/38 from the Side frame L.

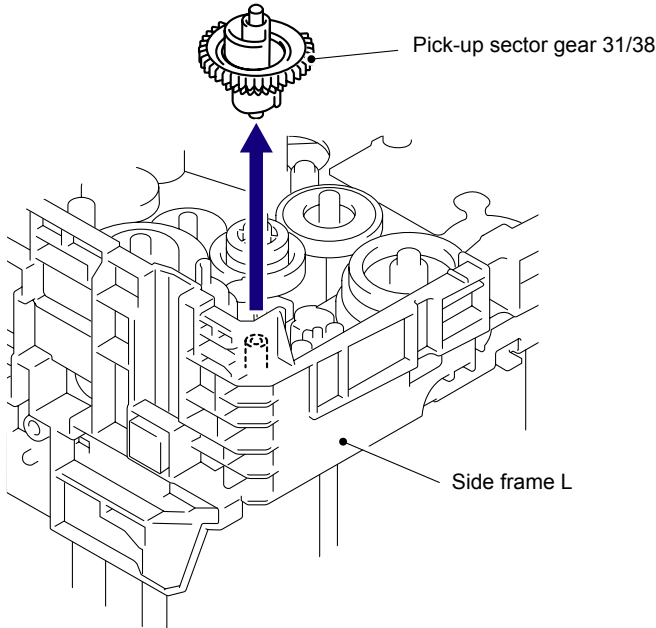

Fig. 5-135

**Assembling Note:**

When assembling the Pick-up sector gear 31/38 onto the Side frame L, make sure to mount the Pick-up solenoid lever as shown in the figure below.

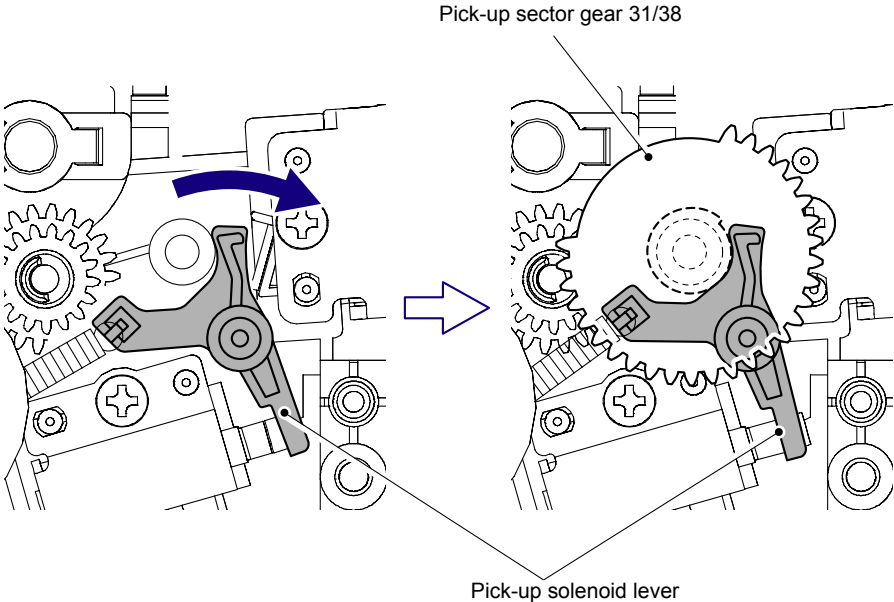
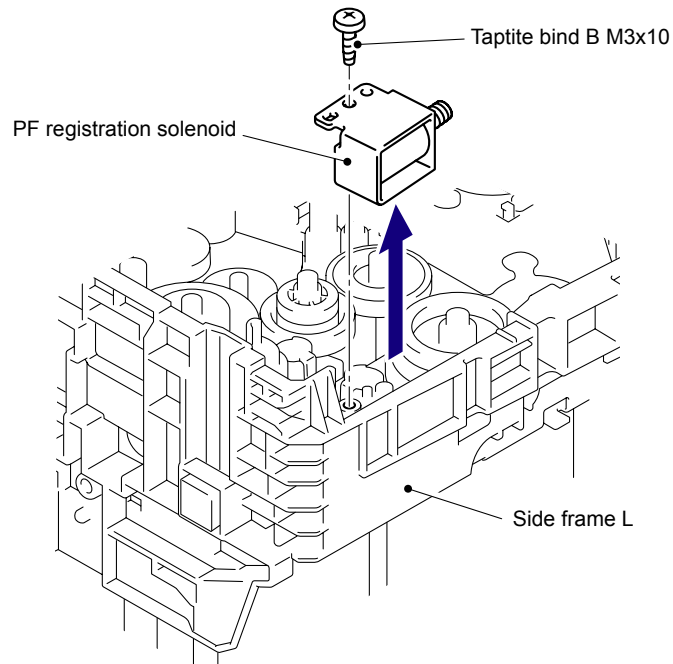

Fig. 5-136



- (2) Remove the Taptite bind B M3x10 screw, and then remove the PF registration solenoid from the Side frame L.



**Fig. 5-137**

- (3) Remove the Registration solenoid spring from the PF registration solenoid.

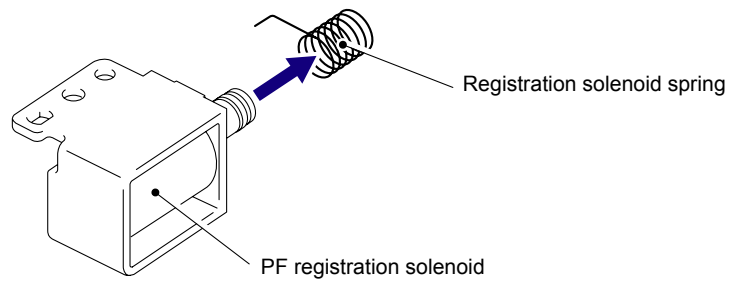

**Fig. 5-138**

**Harness routing:** Refer to "[4 PF Registration Solenoid, Pick-up Solenoid.](#)"

## 8.43 Pick-up Solenoid/Pick-up Solenoid Lever Spring

- (1) Remove the Idle gear 40 from the Side frame L.

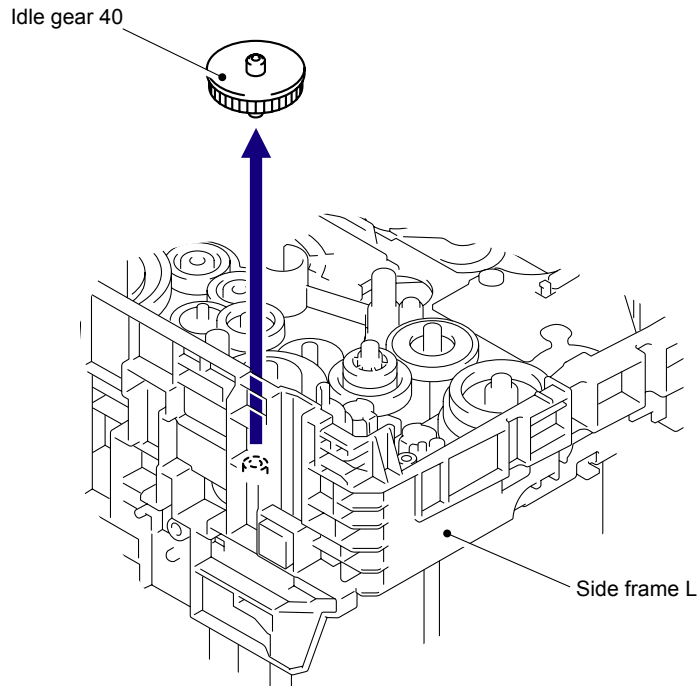

Fig. 5-139

- (2) Remove the Pick-up solenoid lever spring from the Hook of the Pick-up solenoid lever.
- (3) Remove the Pick-up solenoid lever spring from the Side frame L.

**Note:**

Be careful not to loose the Pick-up solenoid lever spring.

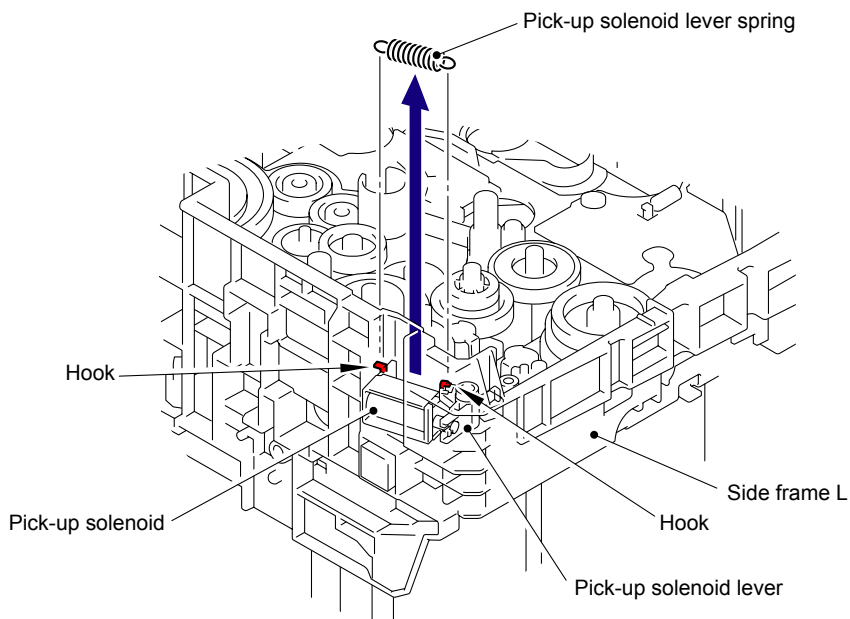
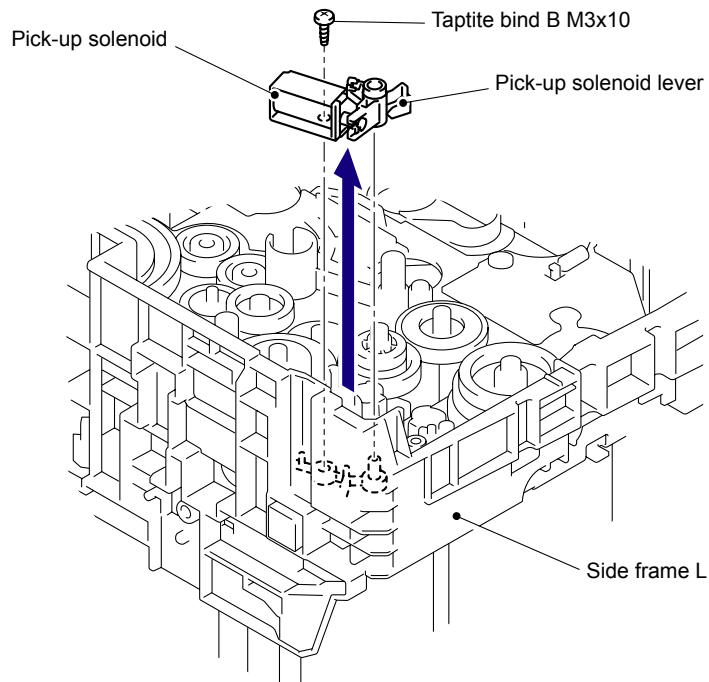

Fig. 5-140

- (4) Remove the Taptite bind B M3x10 screw, and then remove the Pick-up solenoid and Pick-up solenoid lever from the Side frame L.



**Fig. 5-141**

- (5) Remove the Pick-up solenoid lever from the Pick-up solenoid.

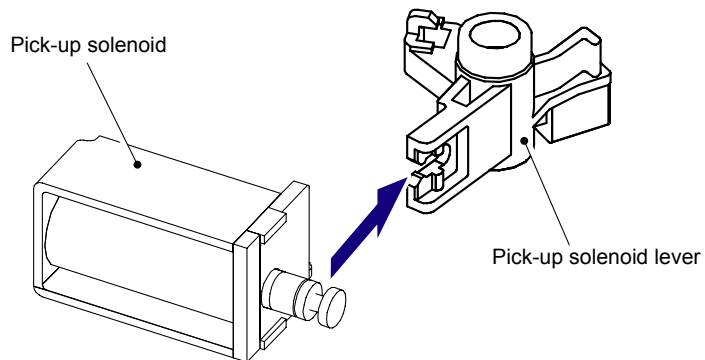

**Fig. 5-142**

**Harness routing:** Refer to "[4 PF Registration Solenoid, Pick-up Solenoid.](#)"

## 8.44 Fuser/Eject Drive Motor

- (1) Remove the Taptite bind B M4x12 screw and Taptite cup S M3x6 SR screw, and then remove the Fuser/Eject drive motor from the Fuser eject drive ASSY.

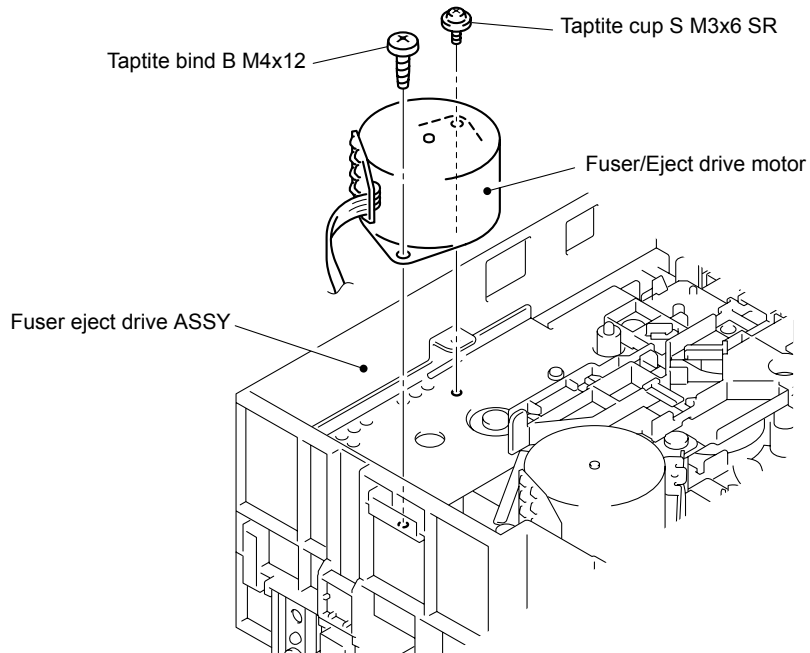

Fig. 5-143

**Harness routing:** Refer to “[8 Fuser/Eject Drive Motor, Fuser/Eject Drive Motor Sensor PCB ASSY.](#)”

## 8.45 Fuser/Eject Drive Motor Sensor PCB ASSY

- (1) Remove the two Taptite bind B M4x12 screws, and then remove the Eject gear cover from the Side frame L.

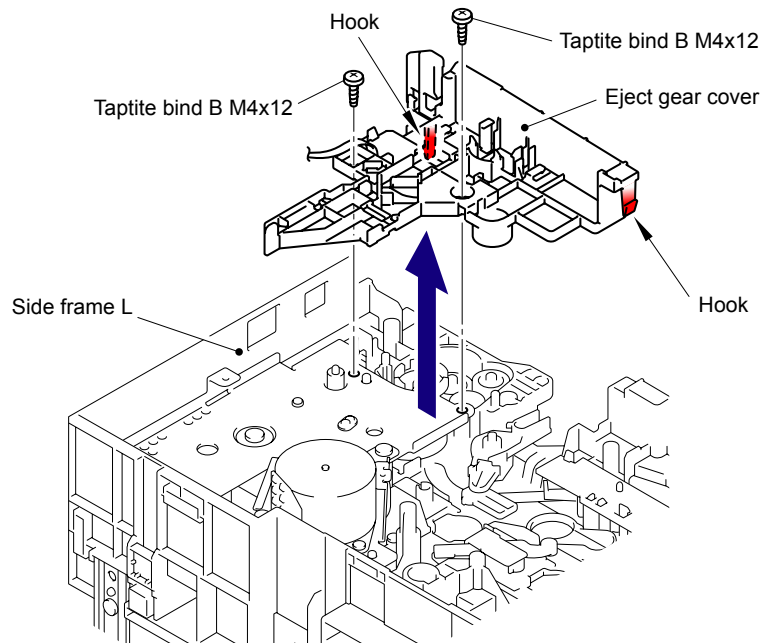

Fig. 5-144

**Note:**

Be careful when changing the setup condition of the main body with the left side up while the Eject gear cover is removed because the gear may fall off.

- (2) Release the Hook to remove the Fuser/eject drive motor sensor PCB ASSY from the Eject gear cover.

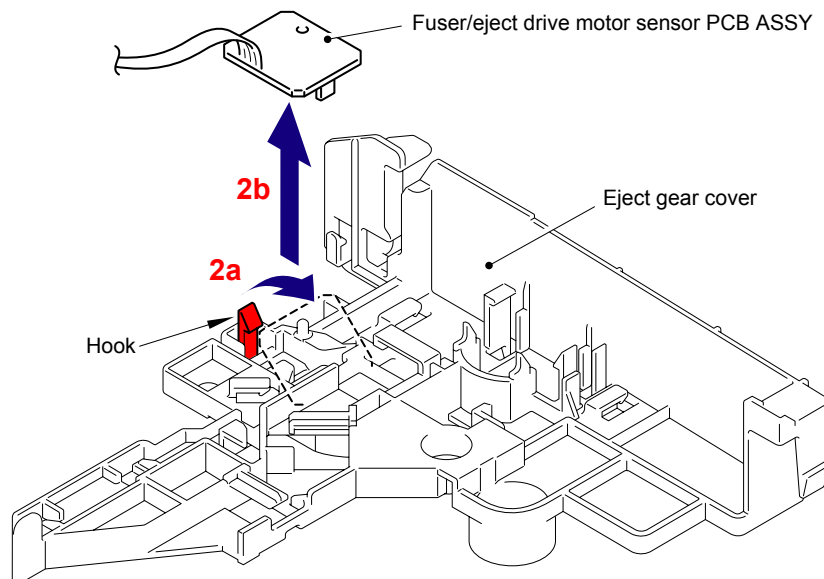

Fig. 5-145

**Harness routing:** Refer to "8 Fuser/Eject Drive Motor, Fuser/Eject Drive Motor Sensor PCB ASSY."

# 8.46 Top Cover Arm R

- (1) Release the Hook to remove the TC arm pivot shaft from the Side frame R.
- (2) Remove the Top cover arm R from the Side frame R.

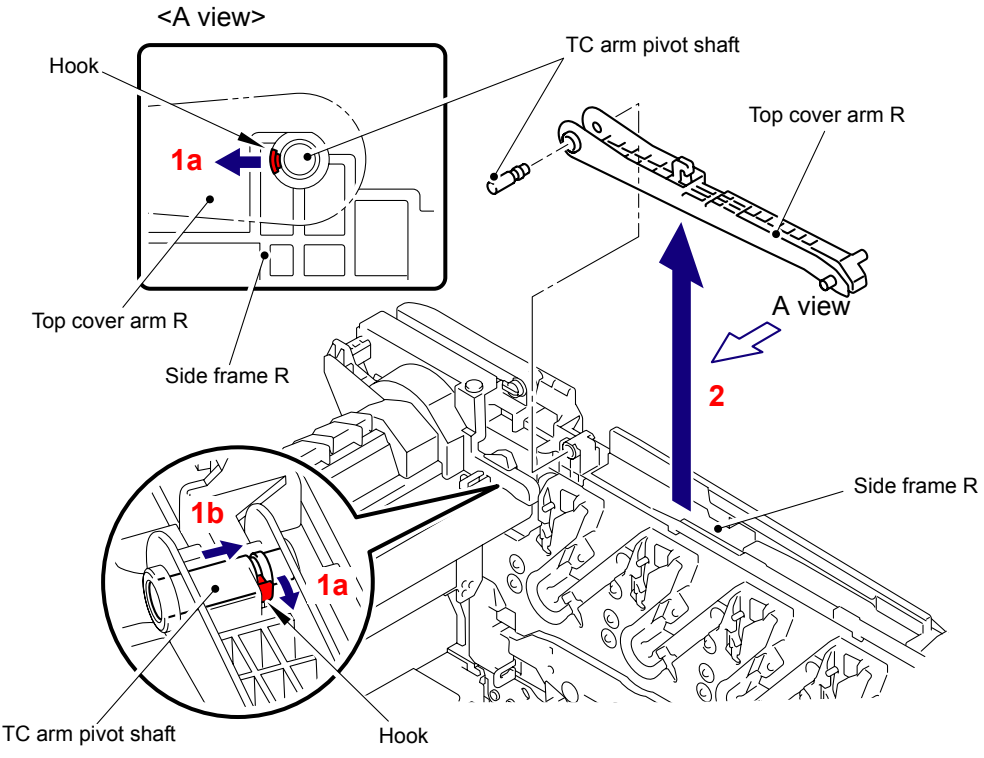

Fig. 5-146

## 8.47 Top Cover Arm L

- (1) Release the Hook to remove the TC arm pivot shaft from the Side frame L.
- (2) Remove the Top cover arm L from the Side frame L.

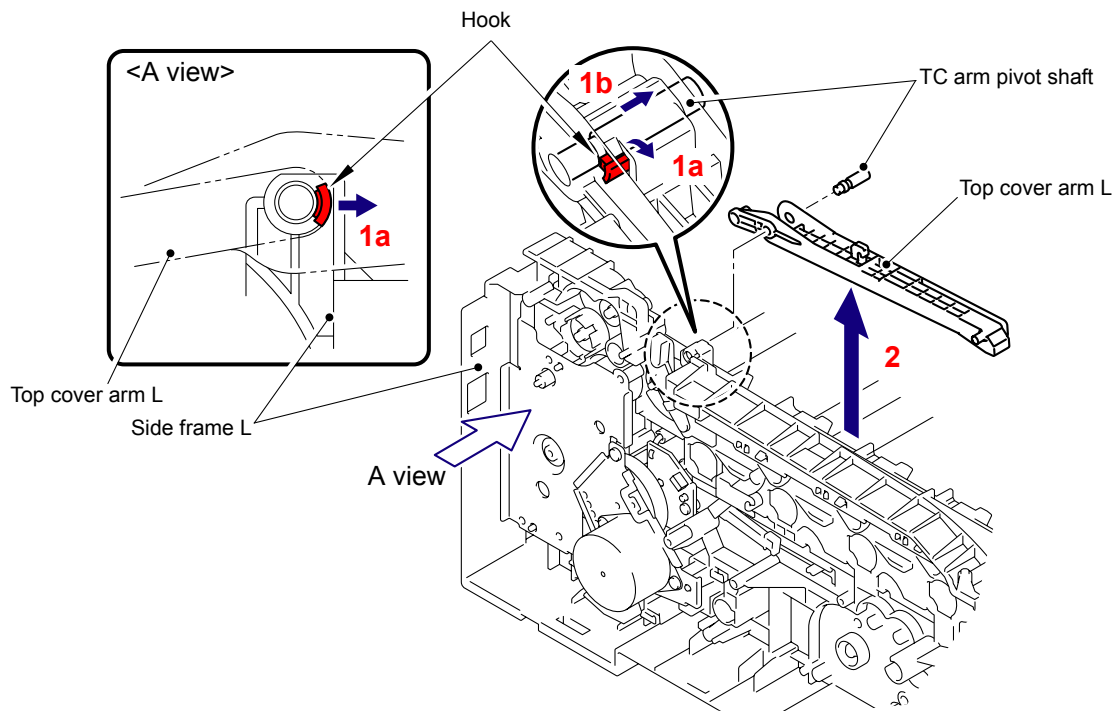

Fig. 5-147

### Assembling Note:

When assembling the Top cover arm L, make sure to fit the "A" of the Top cover arm L into the "B" of the Top cover link 1 before assembling the Top cover arm L onto the Side frame L.

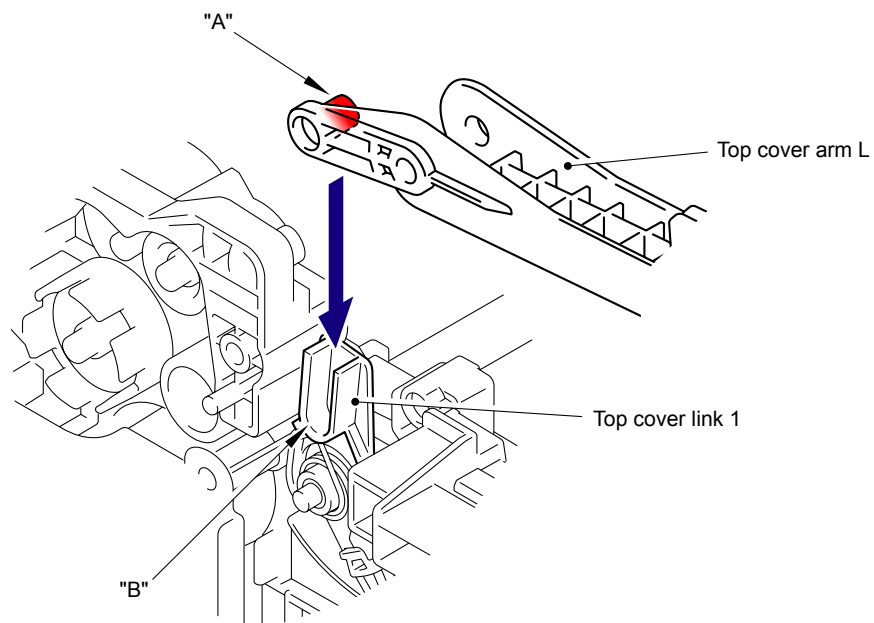

Fig. 5-148

## 8.48 Air Filter Holder ASSY/Ozone Filter

- (1) Remove the two Taptite bind B M4x12 screws from the Paper eject guide ASSY.
- (2) Remove the two Taptite bind B M4x12 screws from the Side frame L and Side frame R.

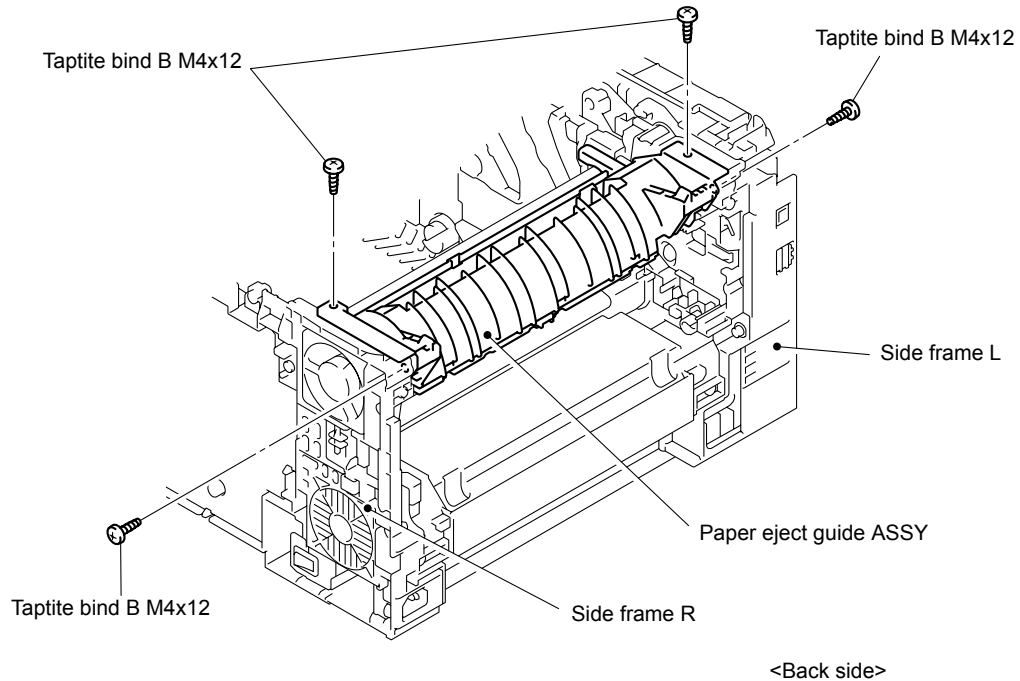

Fig. 5-149

- (3) Open the left and right frames to the outside and remove the Paper eject guide ASSY from the Main body.

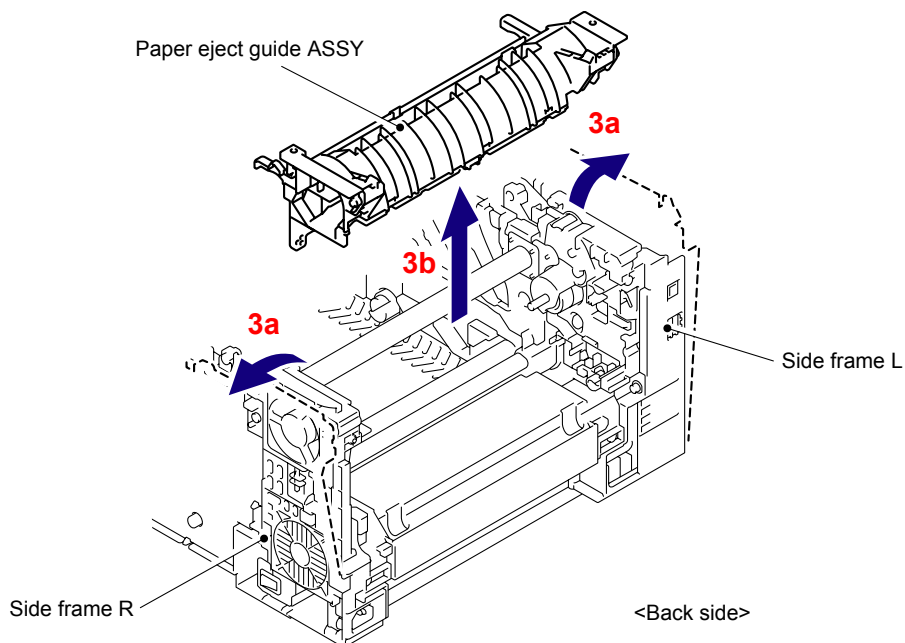

Fig. 5-150



- (4) Release the two Hook A in the direction of the arrow 4a and remove the three Hook B in the direction of the arrow 4b. Then, remove the Paper eject guide from the Lower air duct.

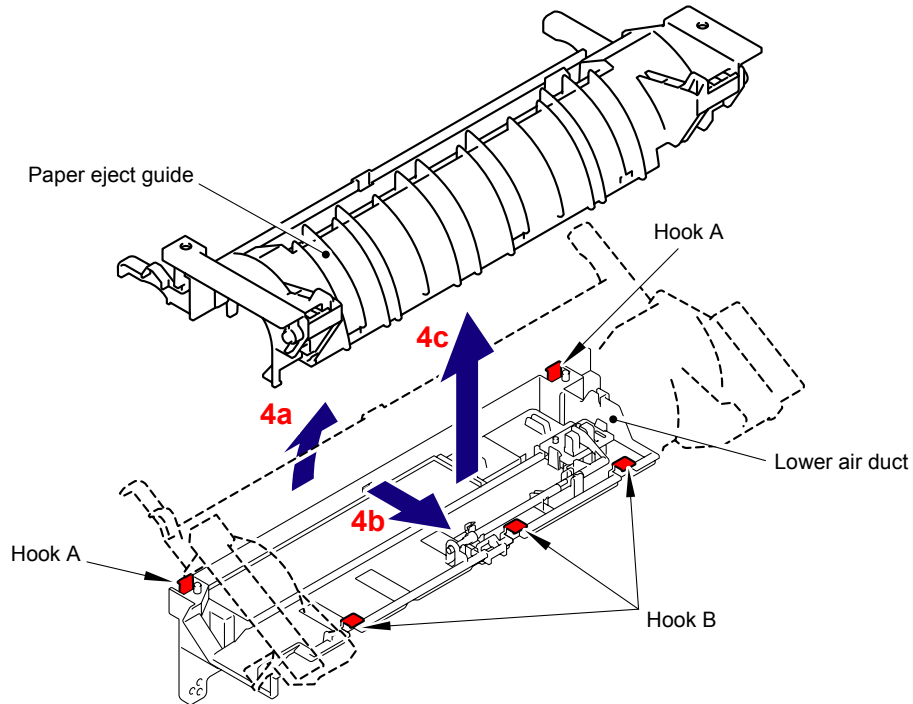

Fig. 5-151

**Assembling Note:**

When assembling the Paper eject guide onto the Lower air duct, make sure to pass the Eject rear harness ASSY through the "A" of the Lower air duct before assembling it.

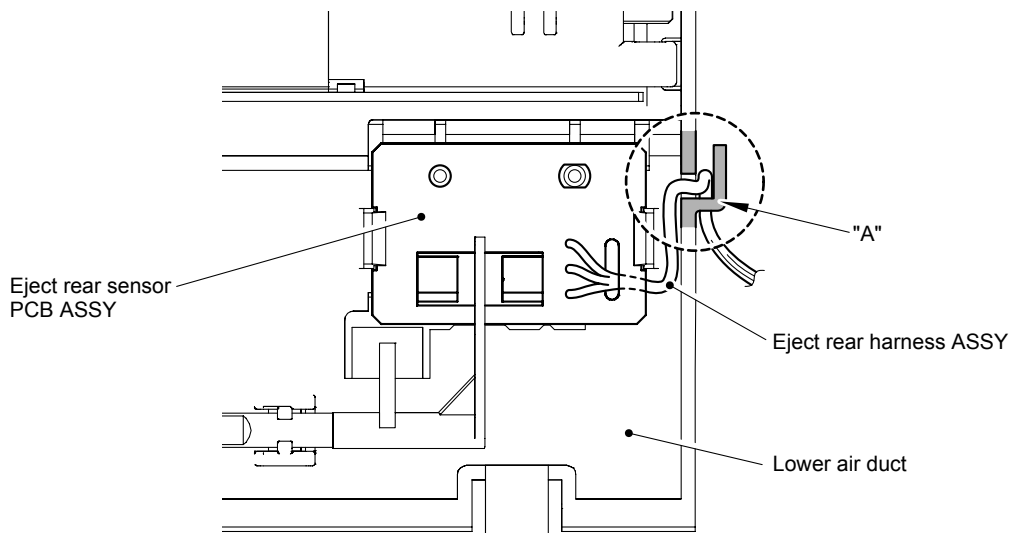

Fig. 5-152

- (5) Remove the Ozone filter from the Air filter holder ASSY.

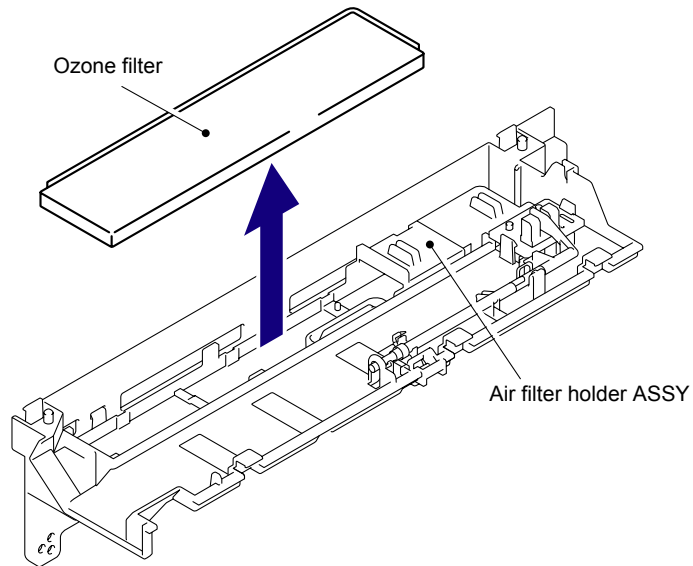

Fig. 5-153

- (6) Release the five Hooks to remove the Air filter holder ASSY from the Lower air duct.

**Note:**

When removing the Air filter holder ASSY from the Lower air duct, be careful not to damage the Toner filter.

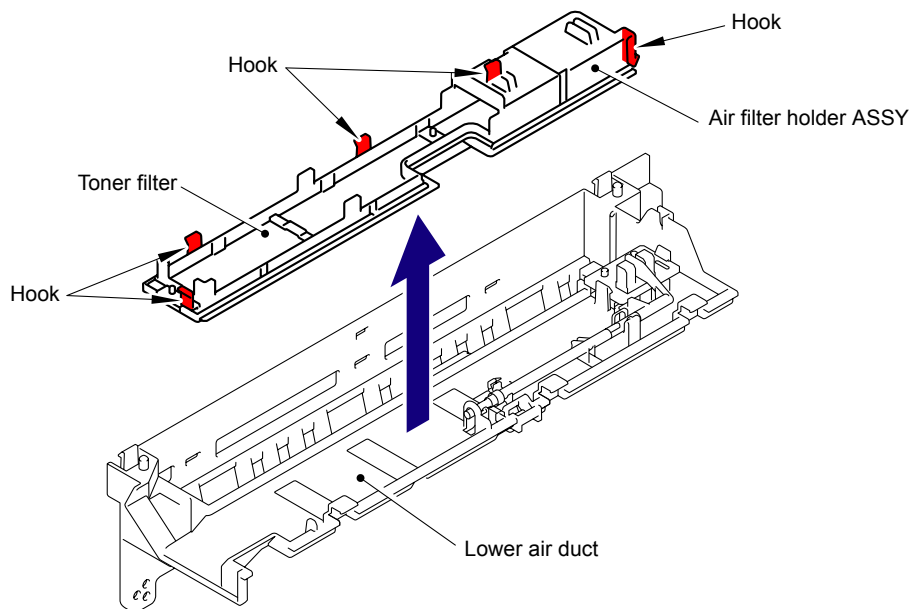

Fig. 5-154

## 8.49 Paper Eject Rear Actuator/Paper Eject Rear Actuator Spring/Paper Eject Rear Actuator Top

- (1) Remove "A" of the Paper eject rear actuator spring from the Hook of the Paper eject rear actuator.
- (2) Turn the Paper eject rear actuator to the direction of the arrow 2a and slide it to the direction of the arrow 2b.  
Adjust "B" of the Paper eject rear actuator to the position of "C" of the Lower air duct. Then, remove the Paper eject rear actuator from the Lower air duct.

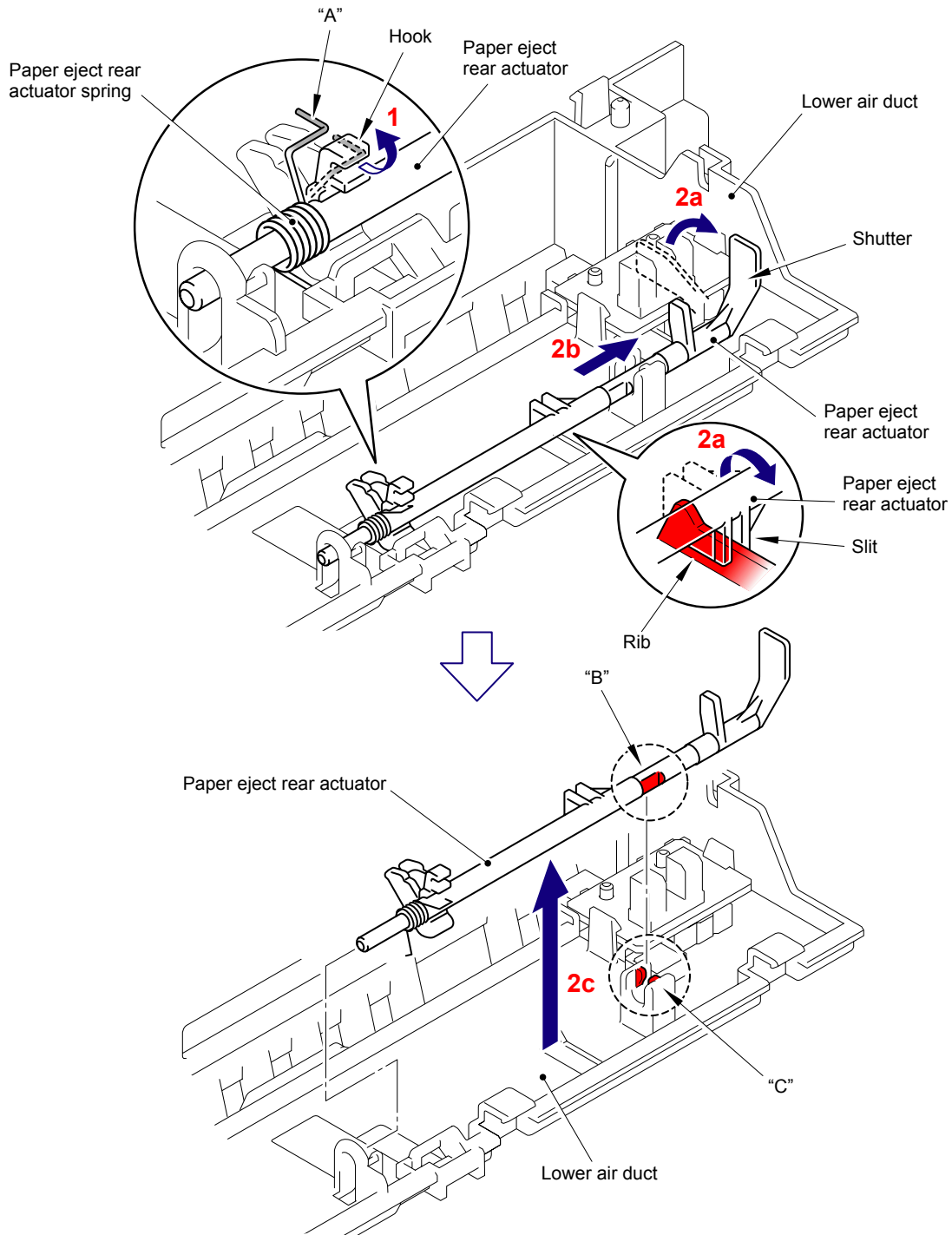

Fig. 5-155

(3) Remove the Paper eject rear actuator spring from the Paper eject rear actuator.

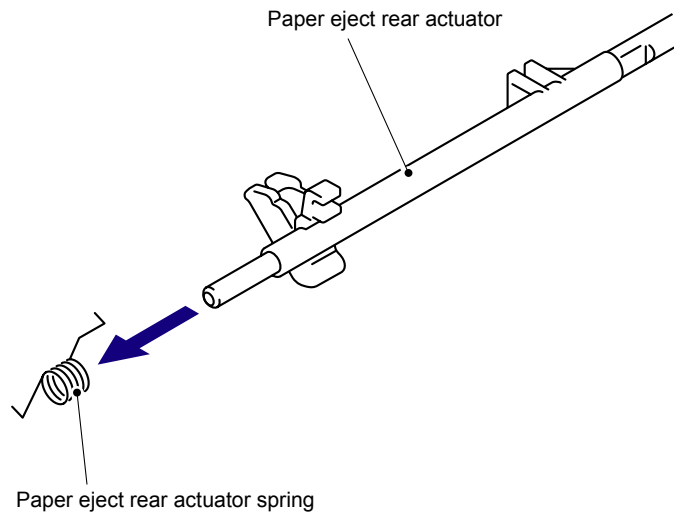

Fig. 5-156

**Assembling Note:**

When assembling the Paper eject rear actuator spring, make sure to mount the Paper eject rear actuator spring as shown in the figure below.

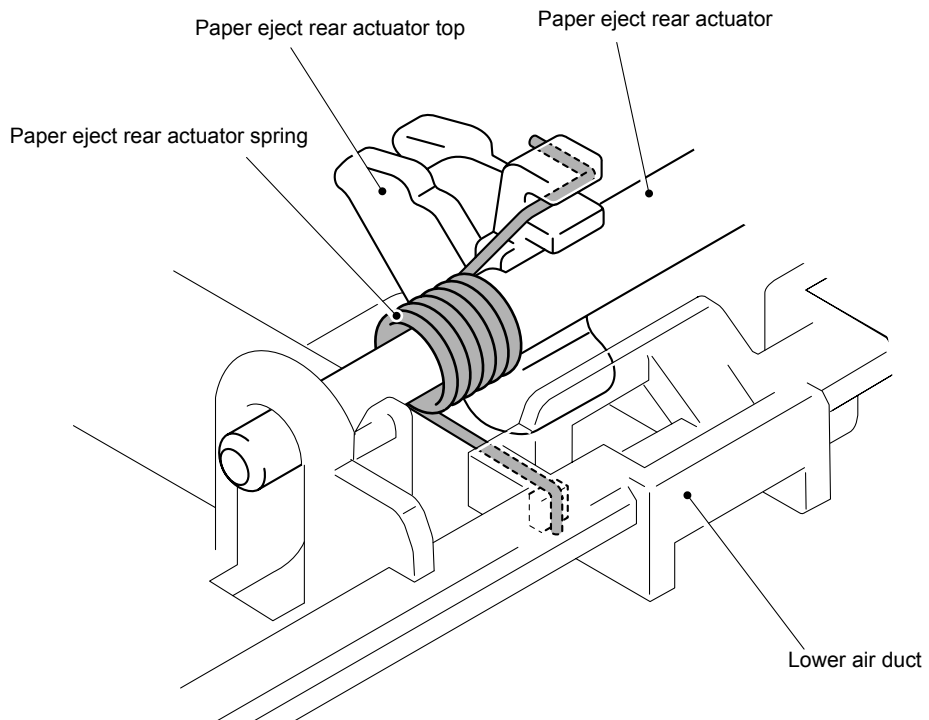

Fig. 5-157

- (4) Rotate the Paper eject rear actuator top in the direction of arrow 4a and remove the Paper eject rear actuator top from the Paper eject rear actuator.

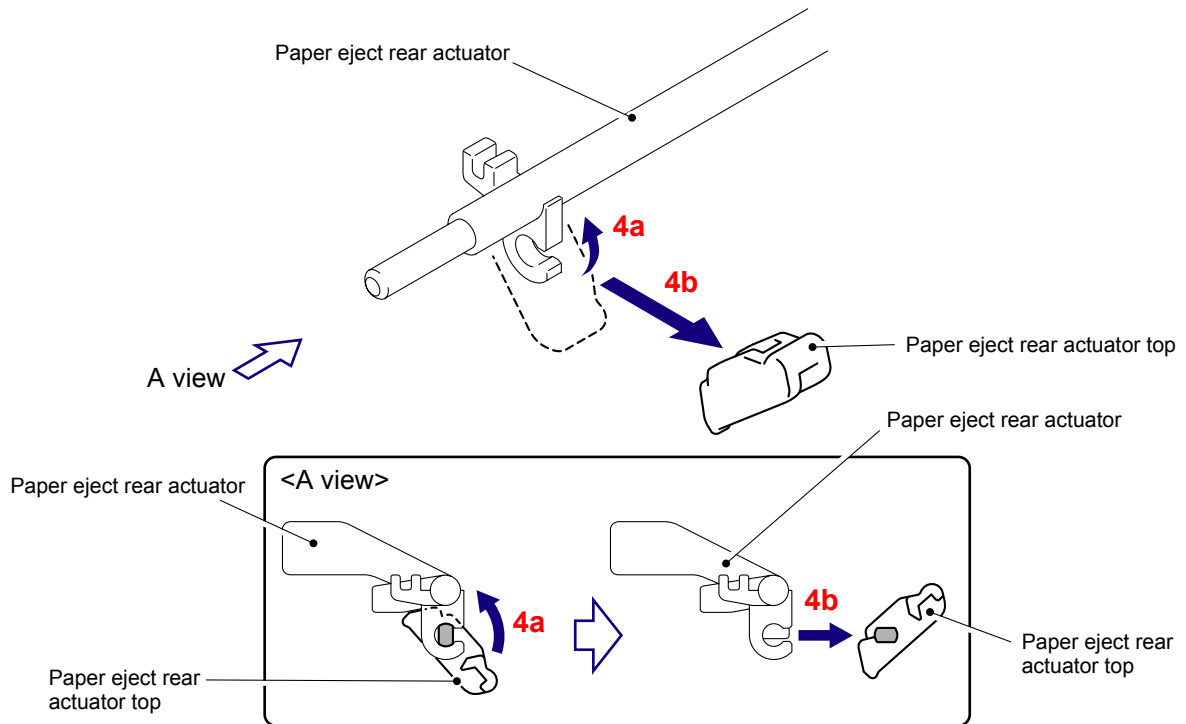

Fig. 5-158

# 8.50 Eject Rear Sensor PCB ASSY

- (1) Release the two Hooks to remove the Eject rear sensor PCB ASSY from the Lower air duct.

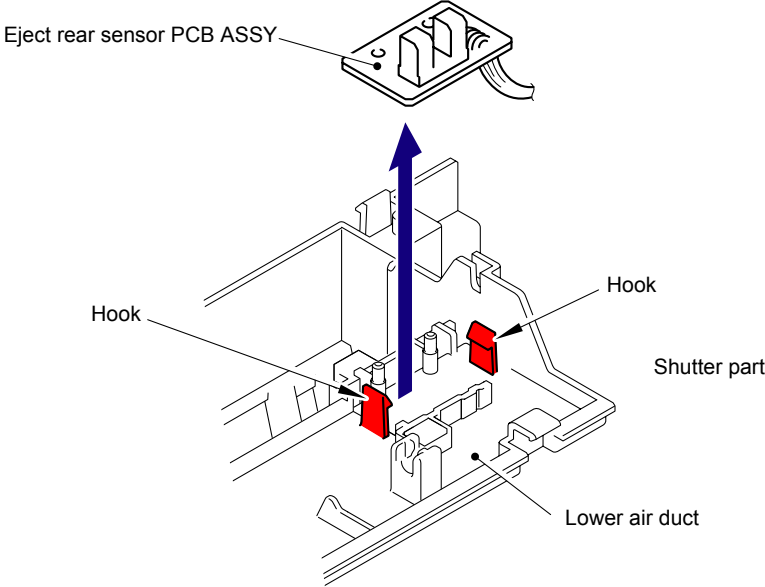

Fig. 5-159

Harness routing: Refer to "14 Eject Rear Sensor PCB ASSY."

# 8.51 Eject Front Sensor PCB ASSY

(1) Release the Hook to remove the Eject front sensor PCB ASSY from the Side frame L.

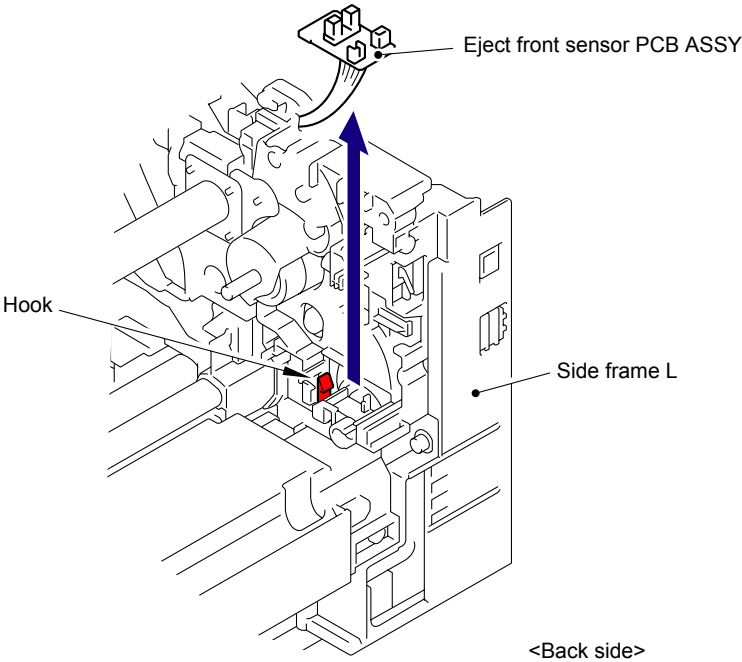

Fig. 5-160

Harness routing: Refer to "15 Eject Front Sensor PCB ASSY."

# 8.52 Toner/New Sensor PCB ASSY

(1) Release the five Hooks to remove the Toner/New sensor PCB ASSY from the Side frame L.

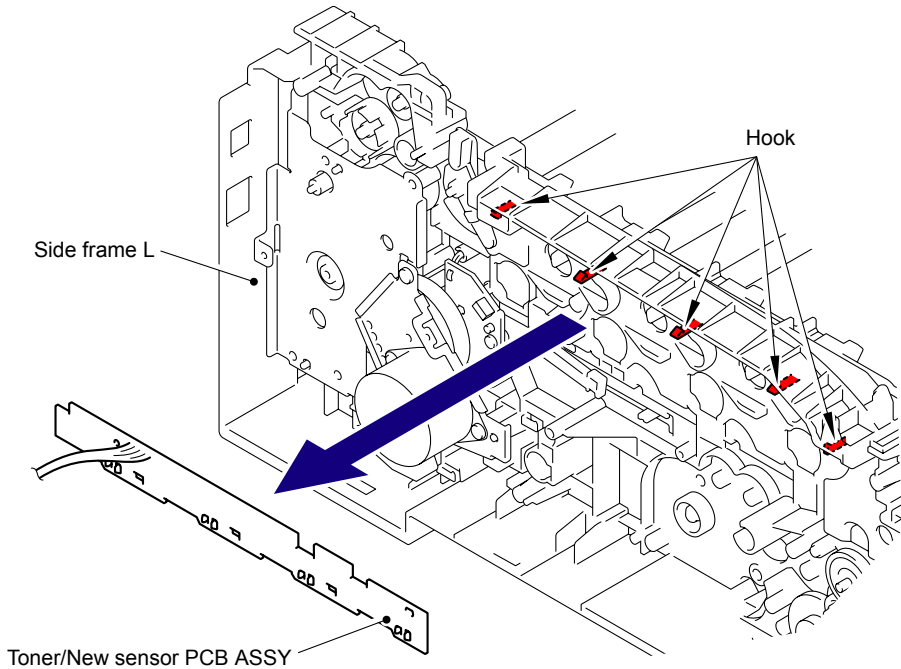

Fig. 5-161

(2) Release the Hooks of the PT sensor holder to remove the four PT sensor holder from the Toner/New sensor PCB ASSY.

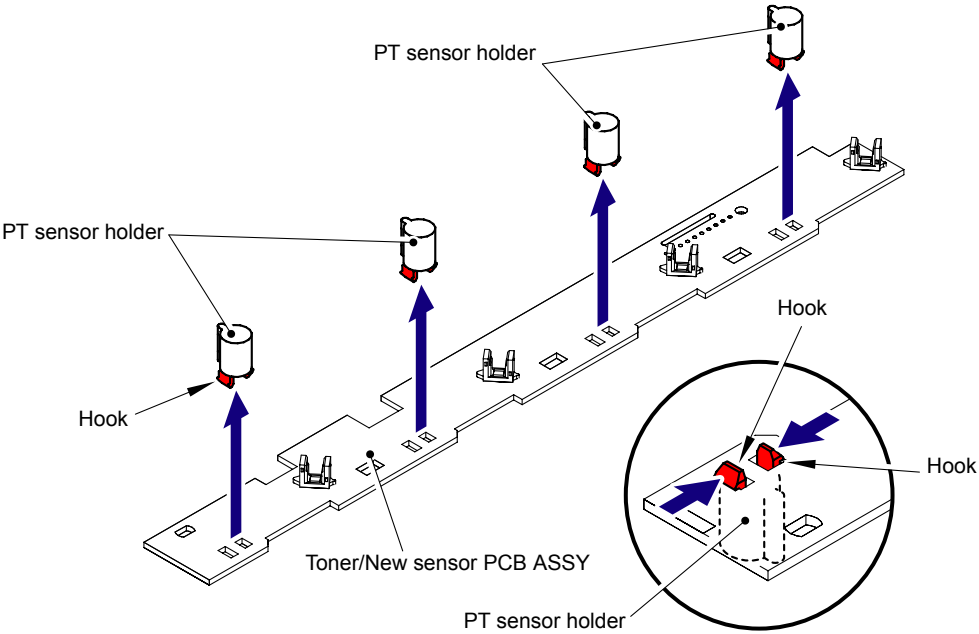

Fig. 5-162

Harness routing: Refer to "9 Toner/New Sensor PCB ASSY."



## 8.53 Belt Drive ASSY

- (1) Remove the three Taptite pan (washer) B M4x12DA screws, and then remove the Belt drive ASSY from the Side frame L.

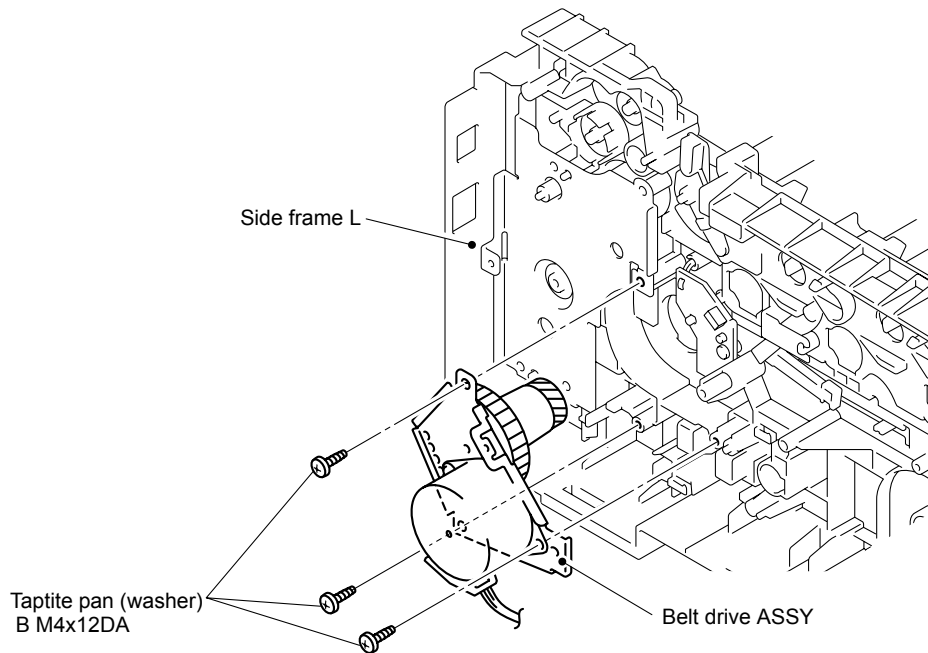
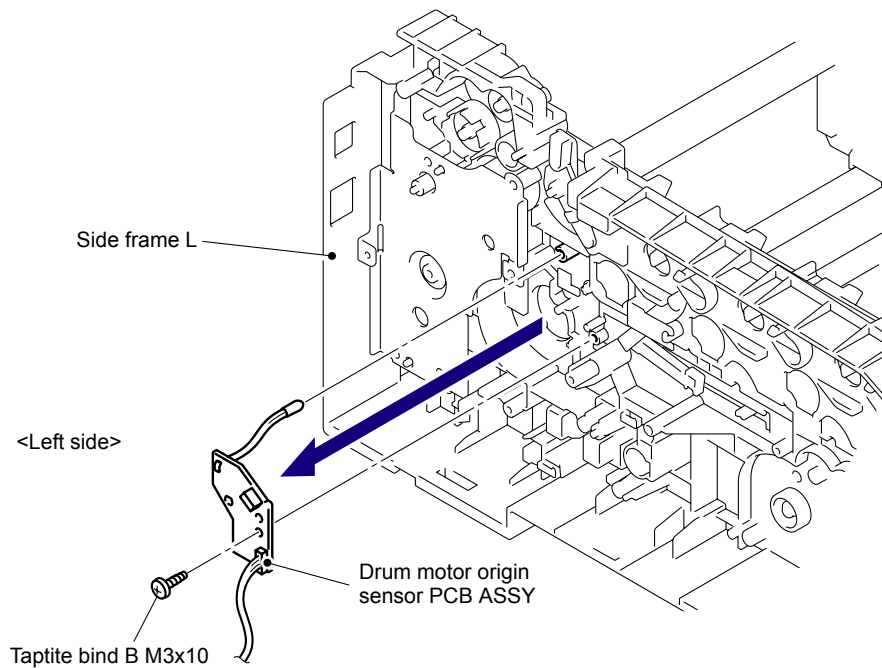

Fig. 5-163

**Harness routing:** Refer to "5 Belt Drive ASSY."

## 8.54 Drum Motor Origin Sensor PCB ASSY

- (1) Remove the Taptite bind B M3x10 screw, and then remove the Drum motor origin sensor PCB ASSY from the Side frame L.



**Fig. 5-164**

**Harness routing:** Refer to "[7 Drum Motor Origin Sensor PCB ASSY.](#)"

# 8.55 LV Fan ASSY

- (1) Remove the Taptite bind B M4x12 screw from the Safety louver.
- (2) Release the two Hooks to remove the Safety louver from the Side frame R.

**Note:**  
Do not pull the Safety louver strongly because it has the Power supply switch on it.

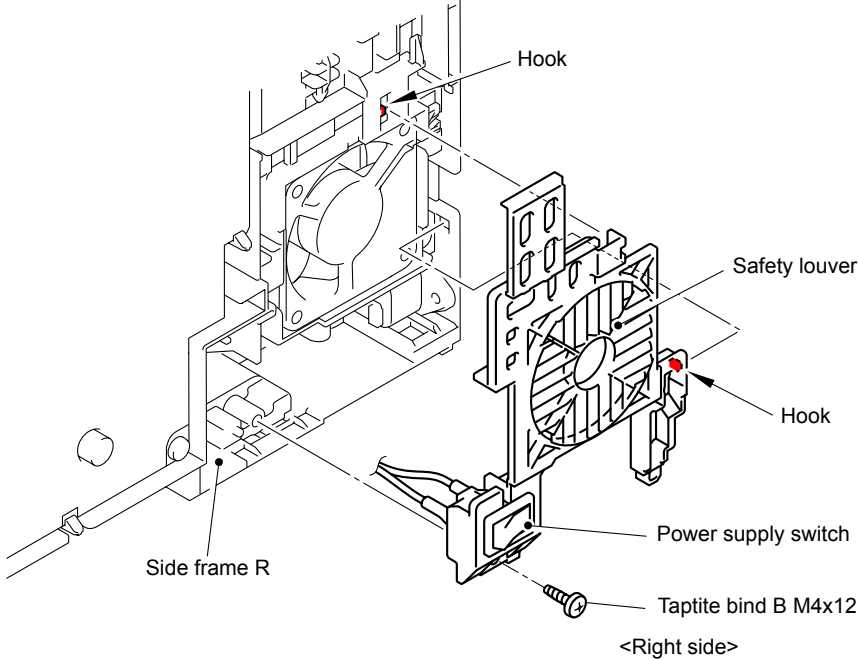

Fig. 5-165

- (3) Disconnect the Connector (CN3) from the High-voltage power supply PCB ASSY.

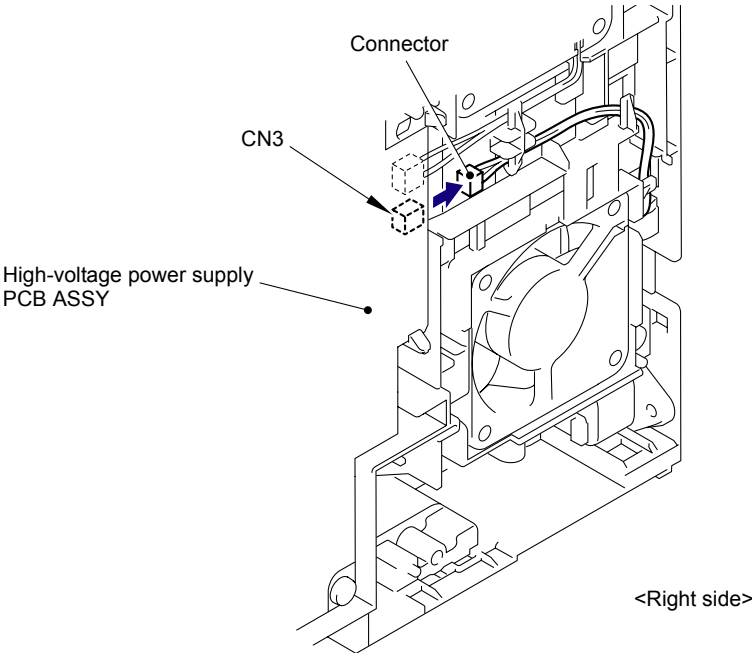
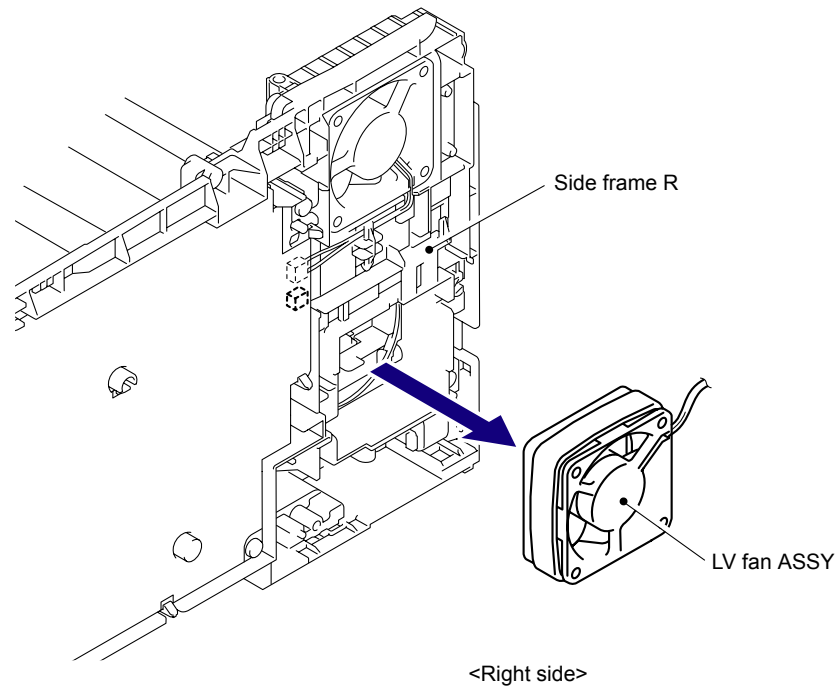

Fig. 5-166

(4) Remove the LV fan ASSY from the Side frame R.



**Fig. 5-167**

**Assembling Note:**

When assembling the LV fan ASSY, place it so that the attached label faces outwards.

**Harness routing:** Refer to "[17](#) Main Fan ASSY, LV Fan ASSY."

## 8.56 Main Fan ASSY

- (1) Disconnect the Connector (CN2) of the Main fan ASSY from the High-voltage power supply PCB ASSY.

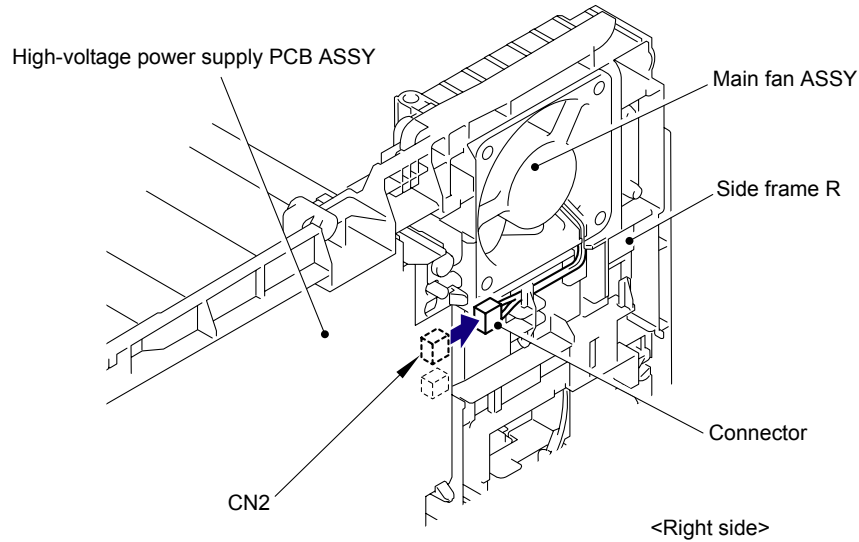

Fig. 5-168

- (2) Remove the Main fan ASSY from the Side frame R.

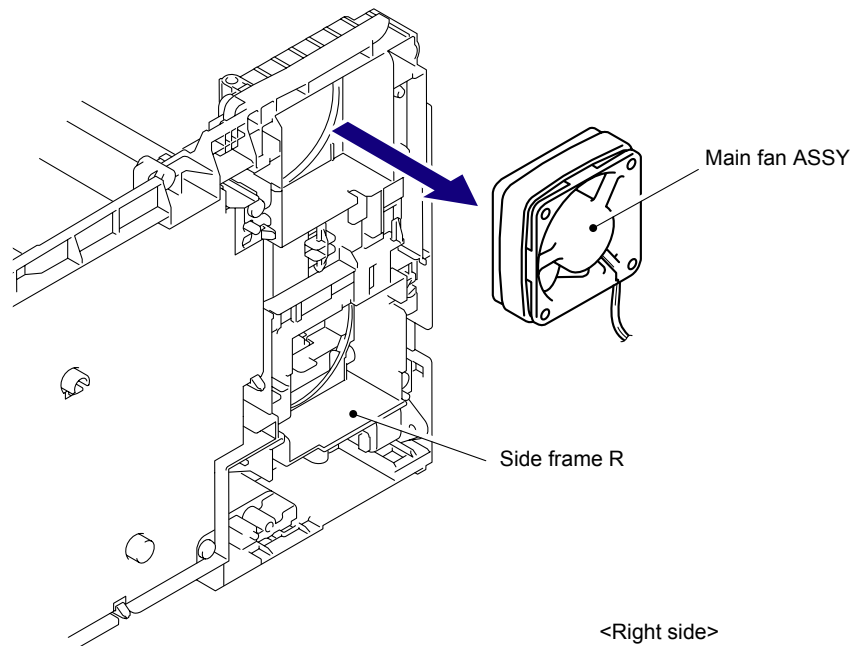

Fig. 5-169

**Assembling Note:**

When assembling the Main fan ASSY, place it so that the attached label faces outwards.

**Harness routing:** Refer to "[17 Main Fan ASSY, LV Fan ASSY.](#)"

# 8.57 Low-voltage Power Supply PCB ASSY

(1) Release the two Hooks to remove the Power supply switch from the Safety louver.

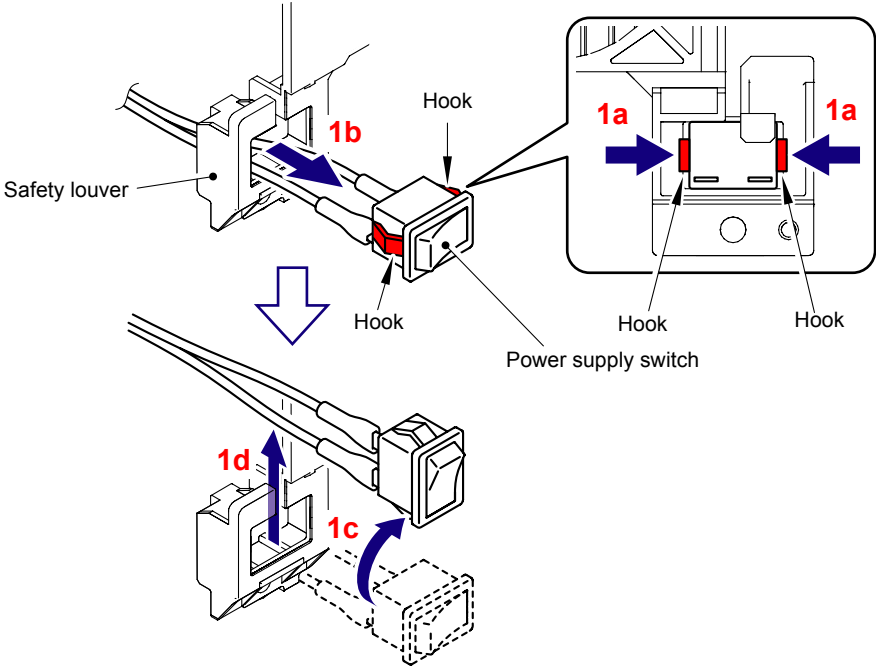

Fig. 5-170

(2) Remove the Screw pan (S/P washer) M4x8 DB and FG harness, and then remove the Inlet from the Side frame R.

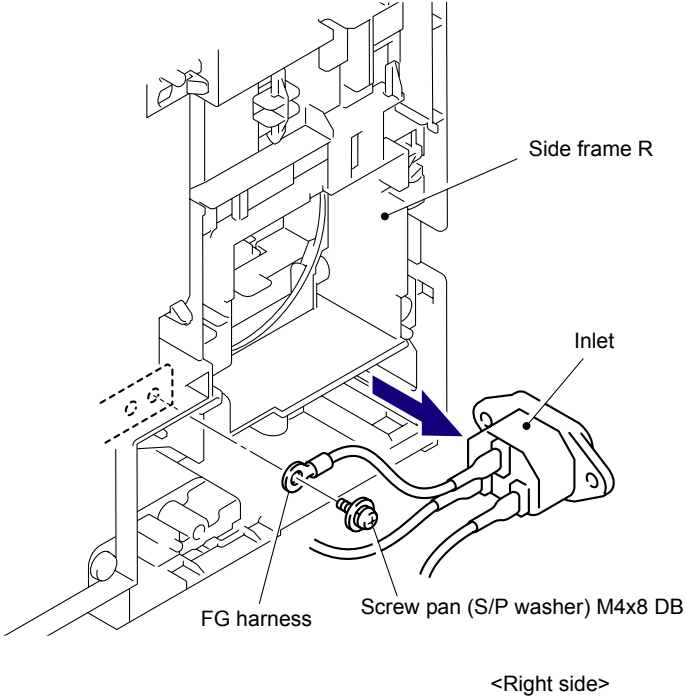
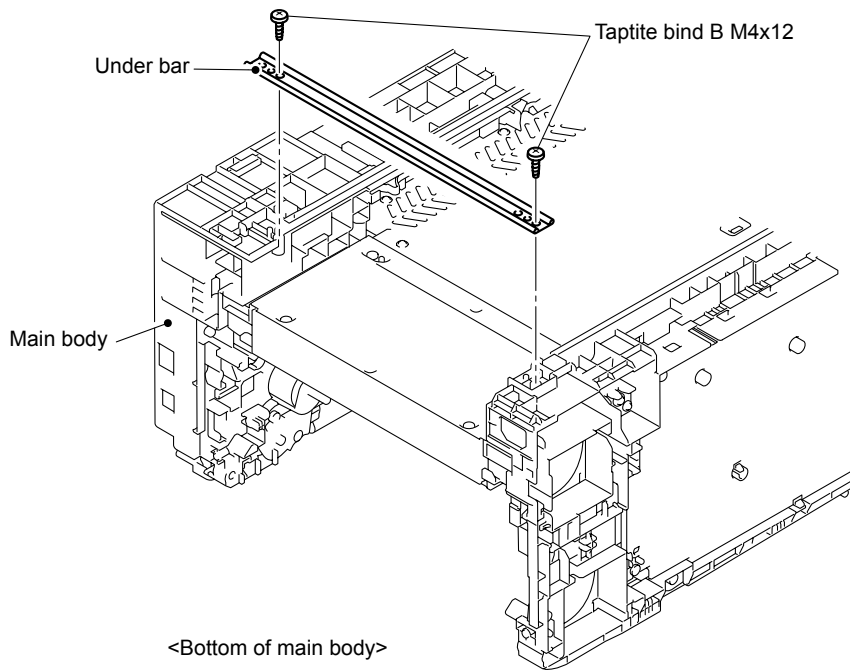

Fig. 5-171

- (3) Turn the Main body upside down.
- (4) Remove the two Taptite bind B M4x12 screws to remove the Under bar from the Main body.



**Fig. 5-172**

- (5) Disconnect the Connector (CN2) of the Heater 120V harness ASSY from the Low-voltage power supply PCB ASSY.

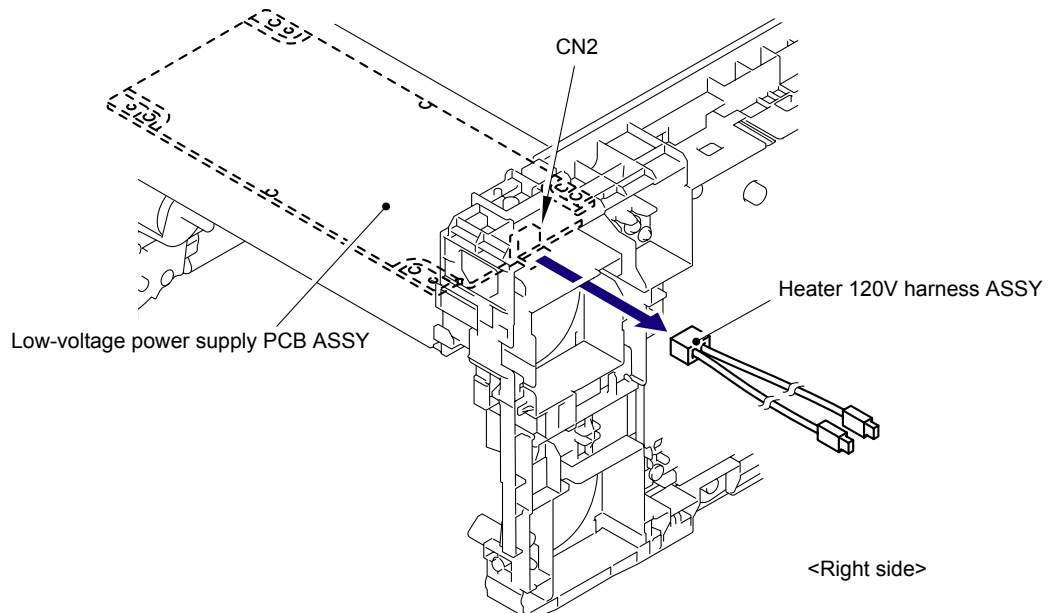

**Fig. 5-173**

- (6) Remove the two Taptite bind B M4x12 screws and two Taptite cup S M3x6 SR screws, and then remove the LVPS unit from the Main body.

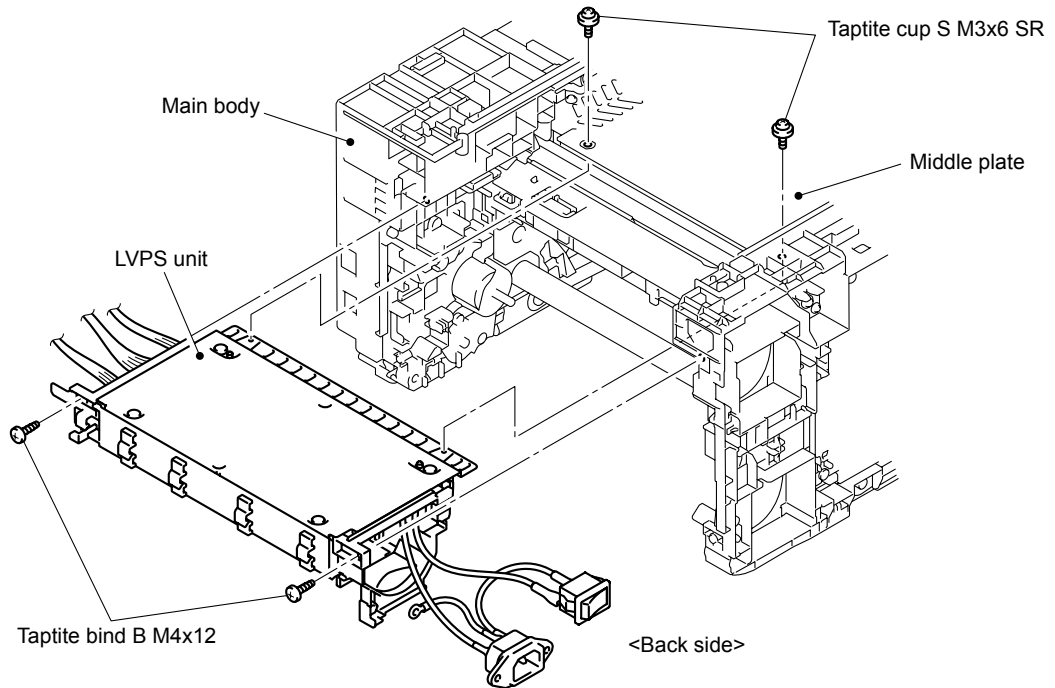

Fig. 5-174

**Assembling Note:**

When assembling the LVPS unit onto the Main body, make sure to assemble it in a way that the LVPS plate is placed at a lower position than the Middle plate.

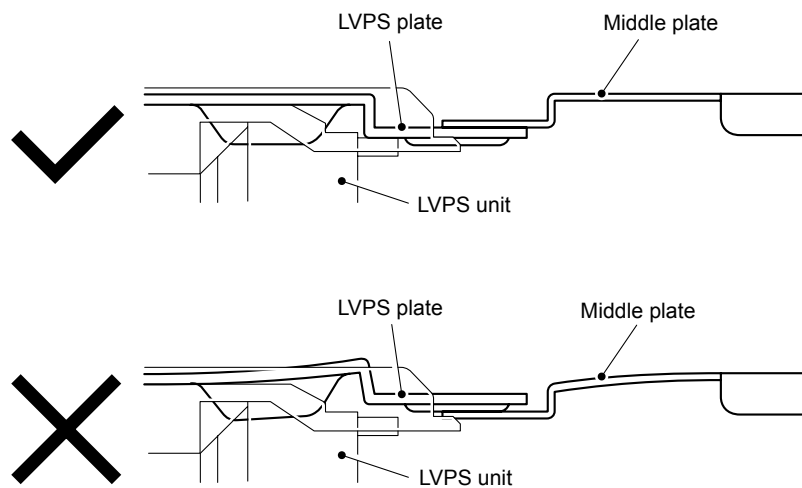
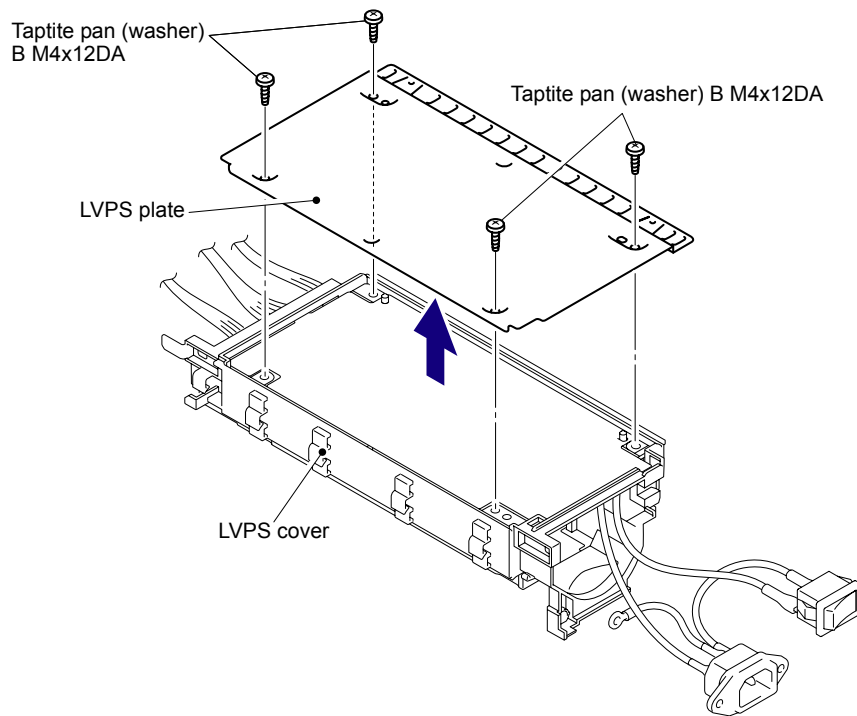

Fig. 5-175



- (7) Remove the four Taptite pan (washer) B M4x12DA screws, and then remove the LVPS plate from LVPS cover.



**Fig. 5-176**

- (8) Remove the LVPS insulation sheet from the LVPS cover.

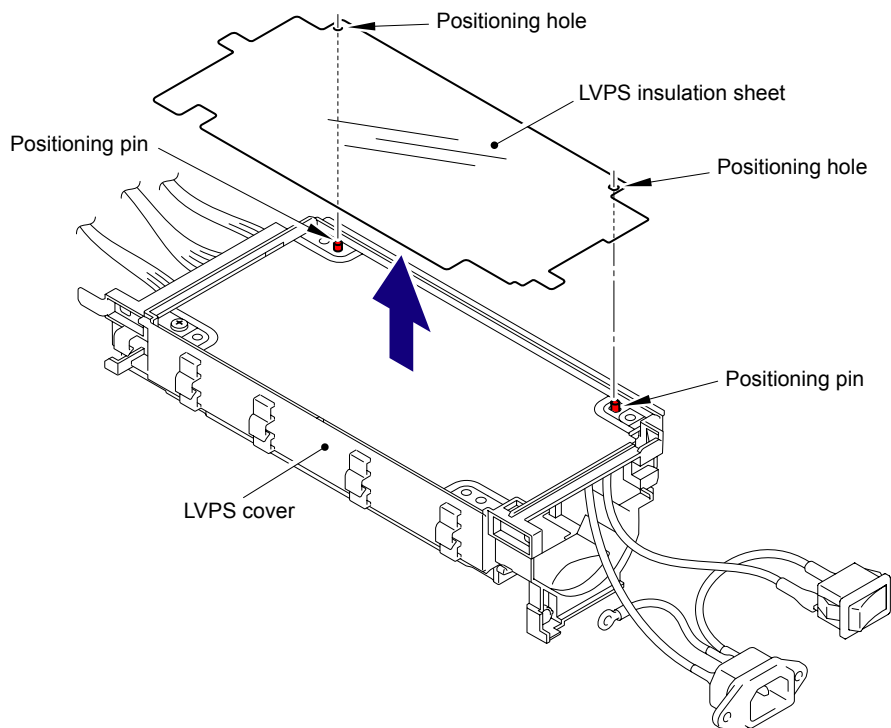

**Fig. 5-177**

- (9) Remove the Taptite pan (washer) B M4x12DA screw, and then remove the Low-voltage power supply PCB ASSY from the LVPS cover.

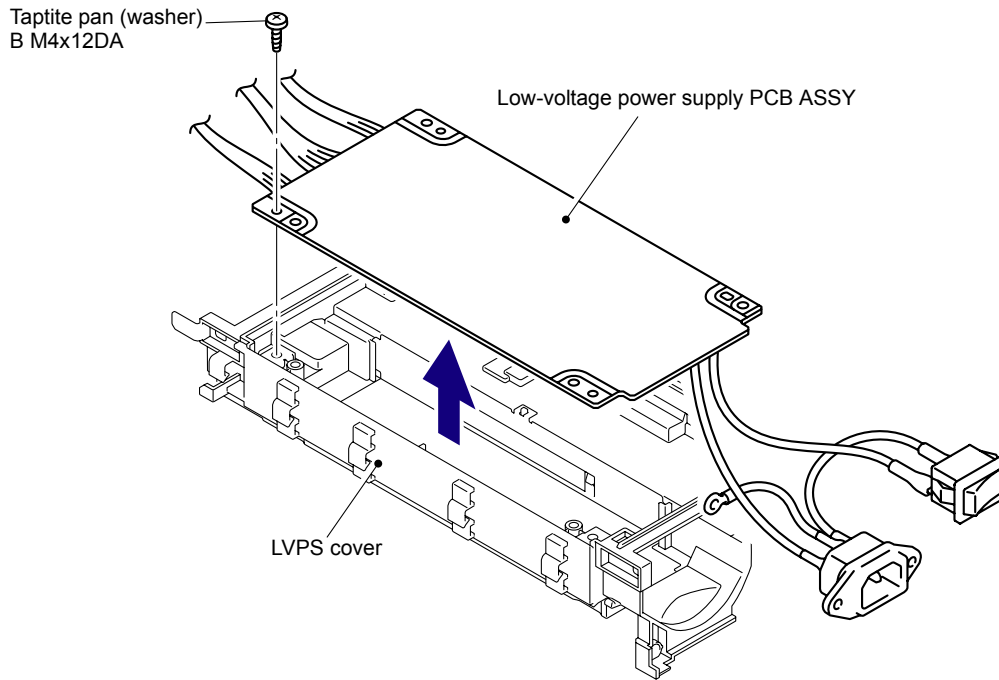

Fig. 5-178

- (10) Disconnect the three Connectors (CN101, CN102, CN103) from the Low-voltage power supply PCB ASSY.

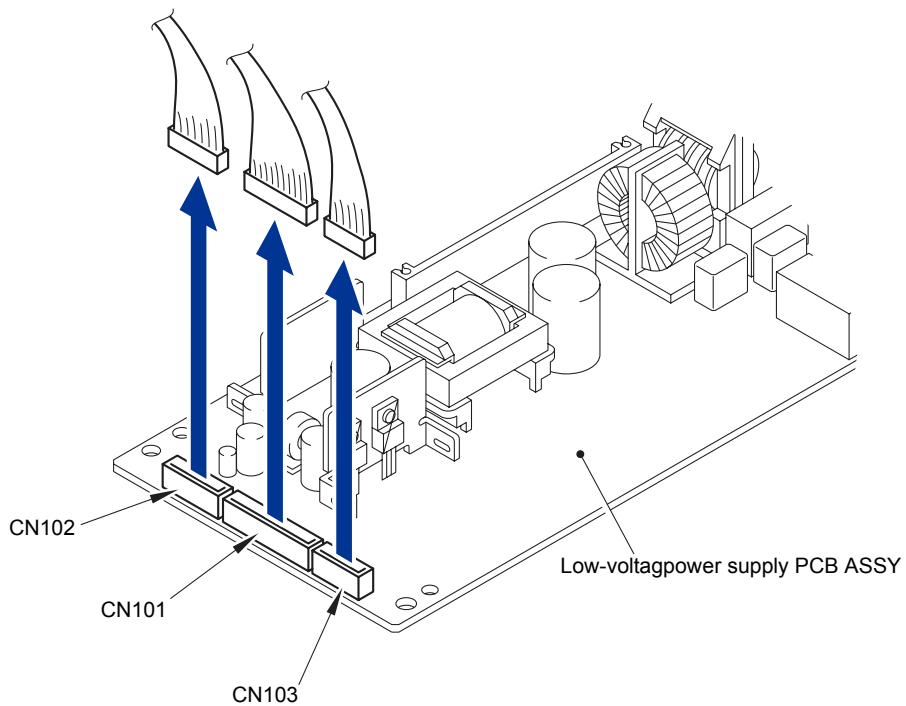

Fig. 5-179

**Harness routing:** Refer to "[20 Low-voltage Power Supply PCB ASSY.](#)"

## 8.58 Registration Sensor Holder ASSY

- (1) Remove the Taptite cup S M3x6 SR screw from the Registration sensor holder ASSY.

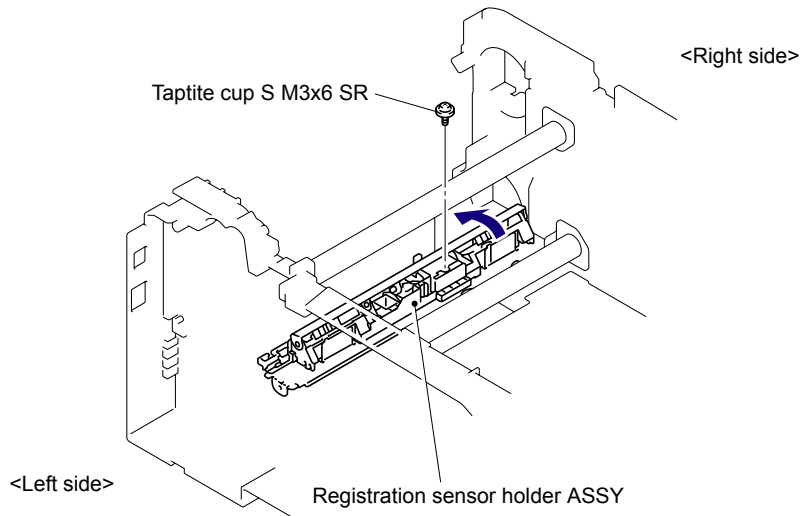

Fig. 5-180

- (2) Wire the harness and release the Hook. Slide the Registration sensor holder ASSY in the direction of the arrow 2a, and remove it from the Registration sensor plate.

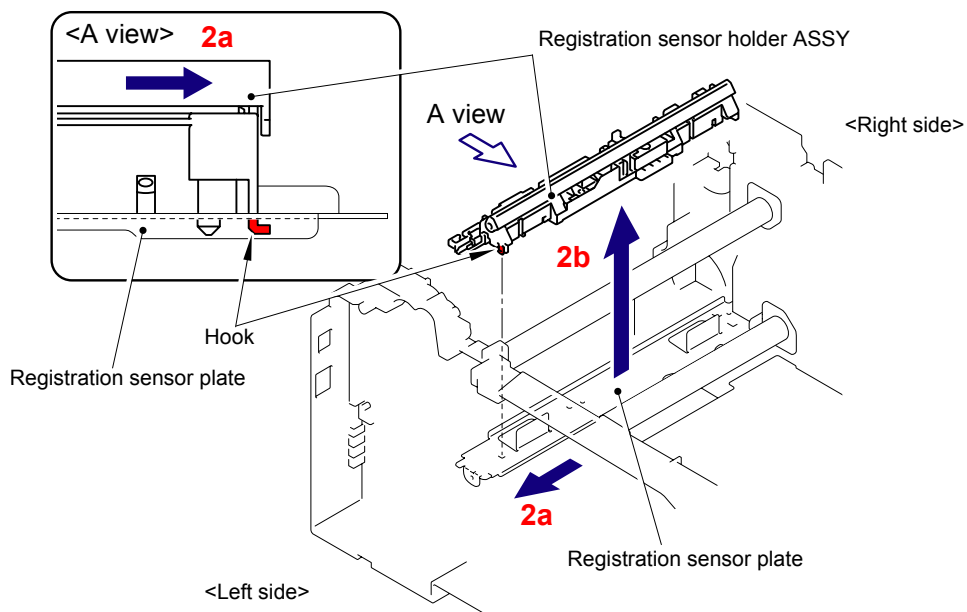

Fig. 5-181

### Assembling Note:

- Be careful not to place the harness between the Registration sensor holder ASSY and the Registration sensor plate when assembling the Registration sensor holder ASSY to the Registration sensor plate.
- A reinforcement plate for transportation is assembled to the Registration sensor holder ASSY (service part). Remove the reinforcement plate for transportation from the Registration sensor holder ASSY before assembling.

**Harness routing:** Refer to "[19 Registration Sensor Holder ASSY.](#)"

# 8.59 High-voltage Power Supply PCB ASSY

- (1) Remove the two Taptite bind B M4x12 screws and two Taptite pan (washer) B M4x12DA screws from the High-voltage power supply PCB ASSY.

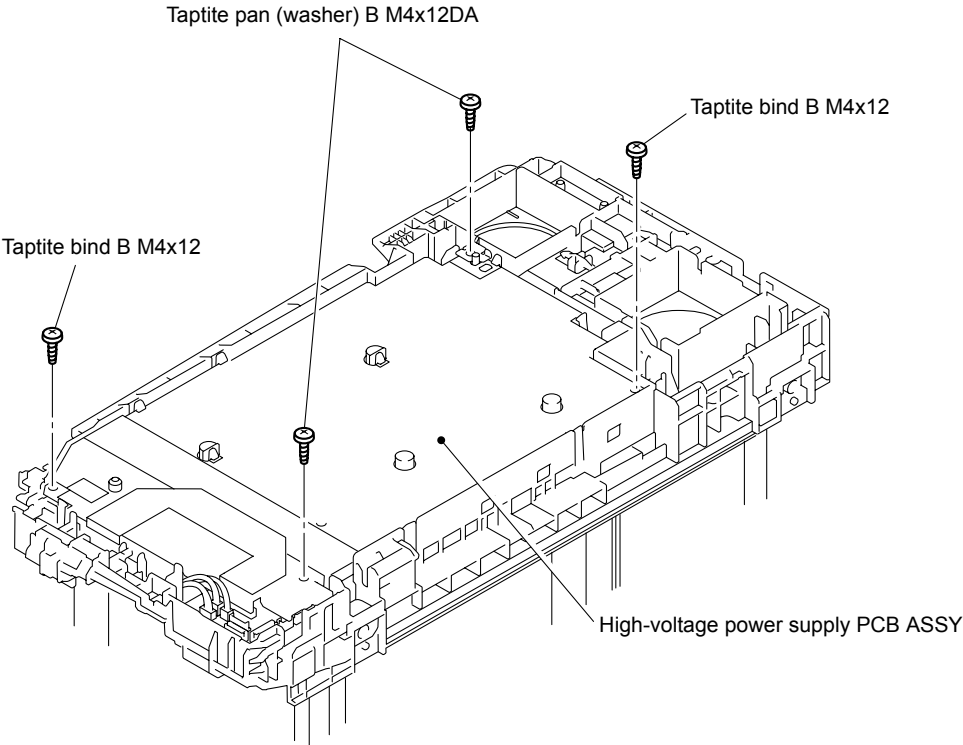

Fig. 5-182

- (2) Remove the Taptite cup S M3x6 SR screw, and then remove the HVPS ground plate 2 from the High-voltage power supply PCB ASSY.

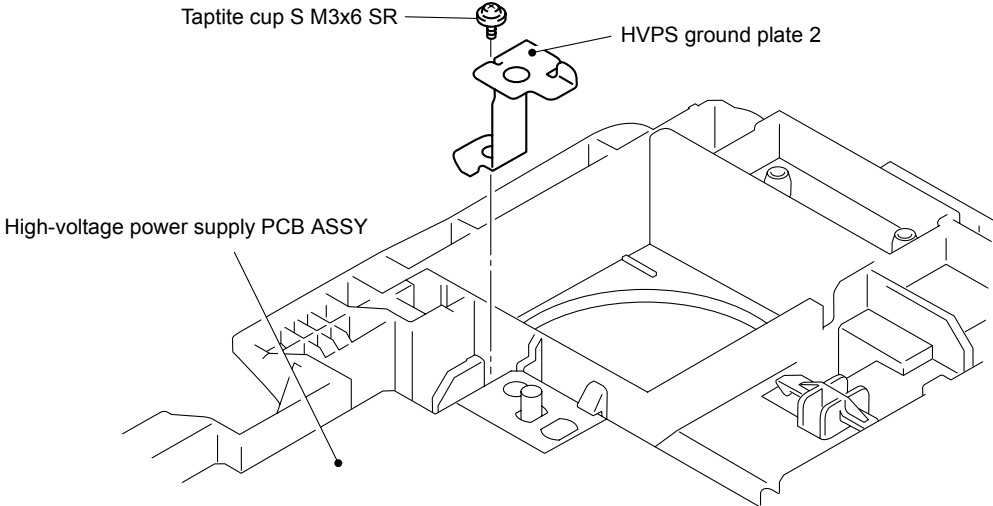
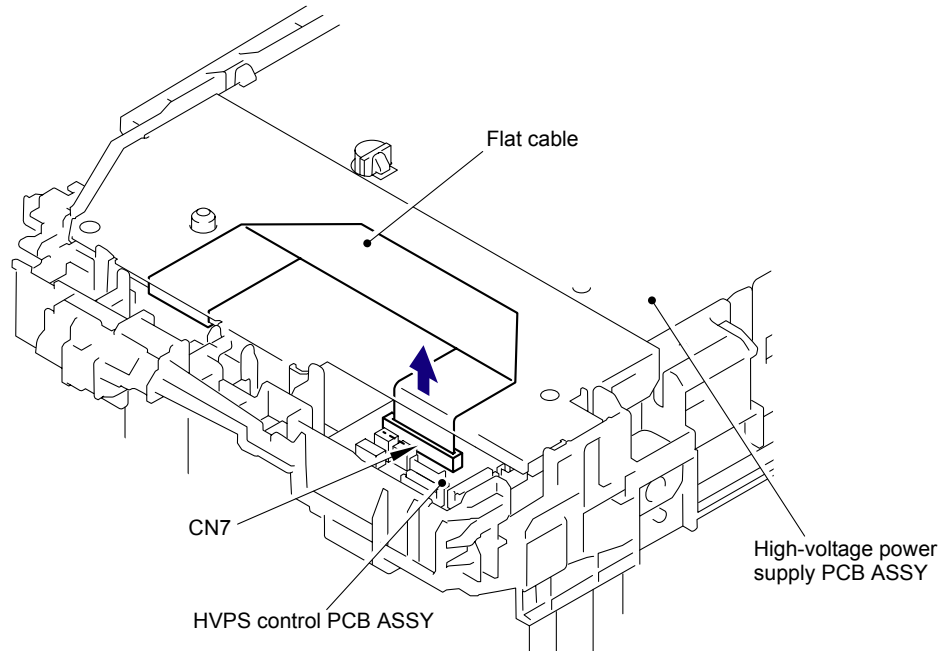

Fig. 5-183

- (3) Disconnect the Flat cable (CN7) of the High-voltage power supply PCB ASSY from the HVPS control PCB ASSY.

**Note:**

- After disconnecting the flat cable(s), check that each cable is not damaged at its end or short-circuited.
- When connecting the flat cable(s), do not insert it at an angle. After insertion, check that the cable is not at an angle.



**Fig. 5-184**

- (4) Remove the two Spacer from the High-voltage power supply PCB ASSY.

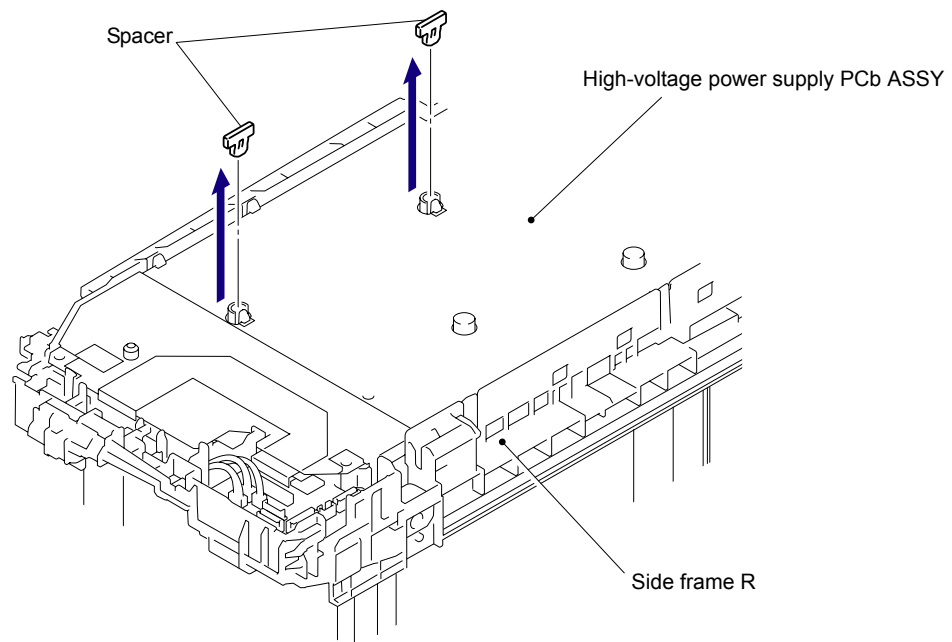

**Fig. 5-185**

- (5) Release the nine Hooks of the side frame R, and remove the high-voltage power supply PCB ASSY together with the HVPS insulation sheet 1 and HVPS insulation sheet 2.

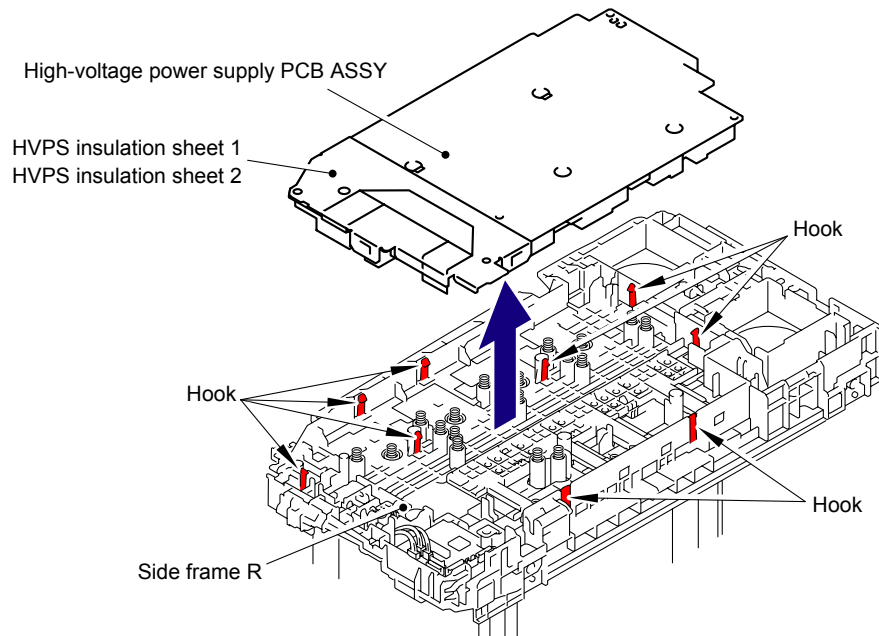

Fig. 5-186

**Assembling Note:**

When replacing the High-voltage power supply PCB ASSY with a new one, fold the FFC first in accordance with the “How to Fold FFC of High-voltage power supply PCB ASSY” figure in the [next page](#), and then assemble the High-voltage power supply PCB ASSY.

<How to Fold FFC of High-voltage power supply PCB ASSY FFC> (full-scale)

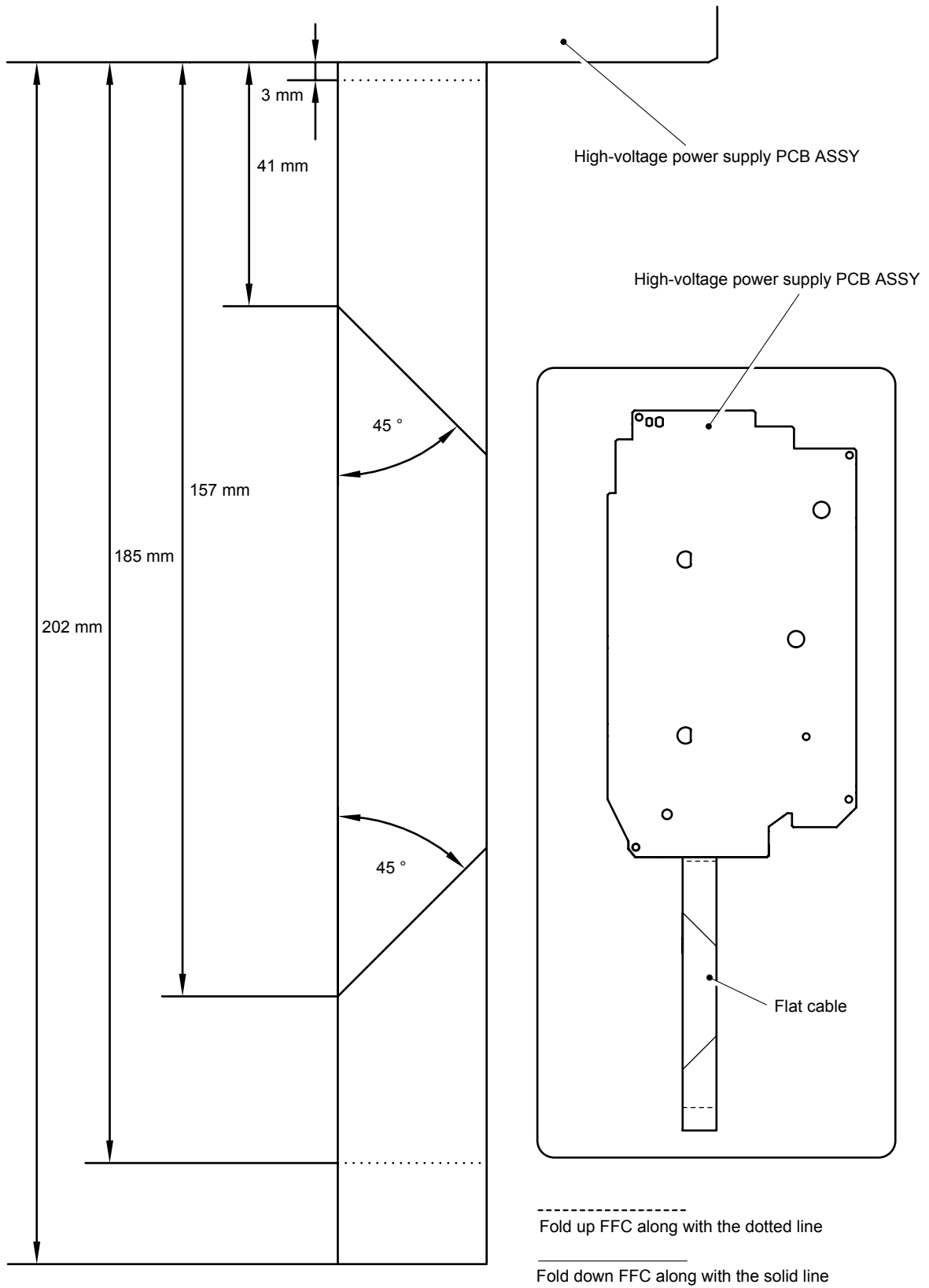
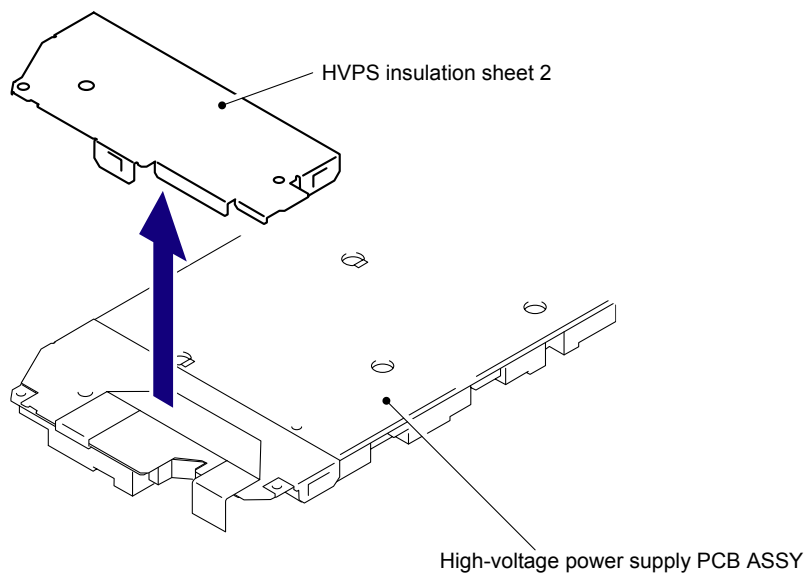

Fig. 5-187

(6) Remove the HVPS insulation sheet 2 from the High-voltage power supply PCB ASSY.



**Fig. 5-188**



(7) Remove the HVPS insulation sheet 1 from the High-voltage power supply PCB ASSY.

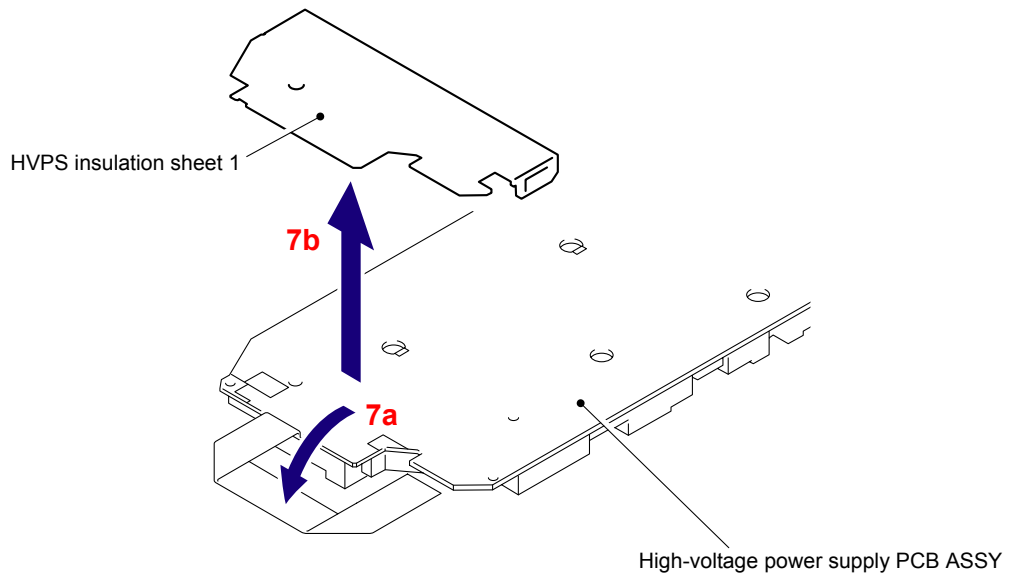

Fig. 5-189

**Assembling Note:**

When assembling the HVPS insulation sheet 1 and HVPS insulation sheet 2, make sure to assemble them as sandwiching the Flat cable of the High-voltage power supply PCB ASSY with them.

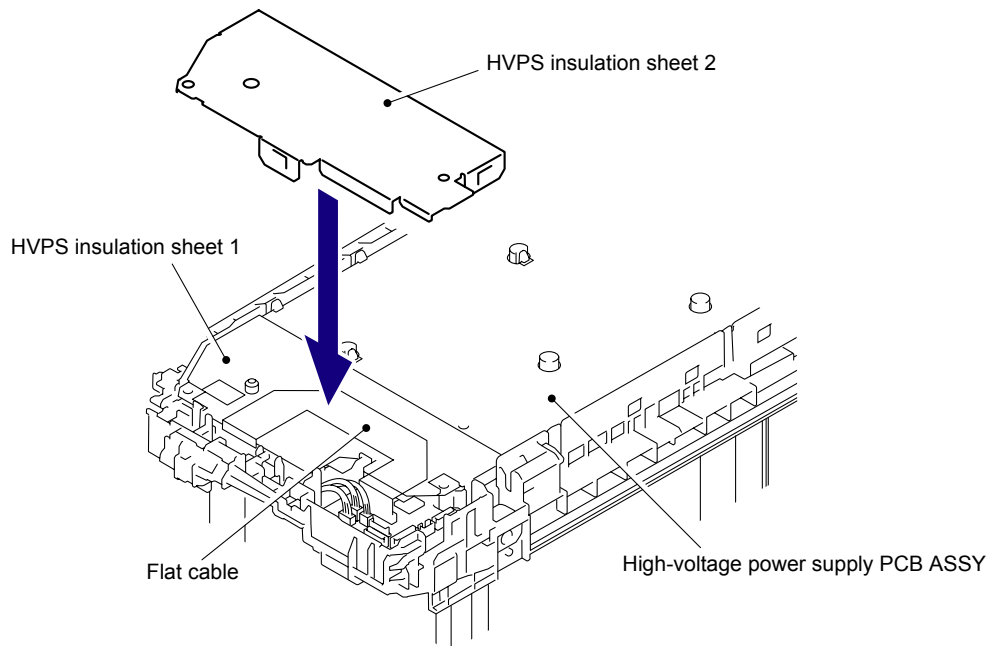

Fig. 5-190

# 8.60 HVPS Control PCB ASSY

- (1) Disconnect the six Connectors (CN1, CN4, CN5, CN8, CN9, CN10) from the HVPS control PCB ASSY.

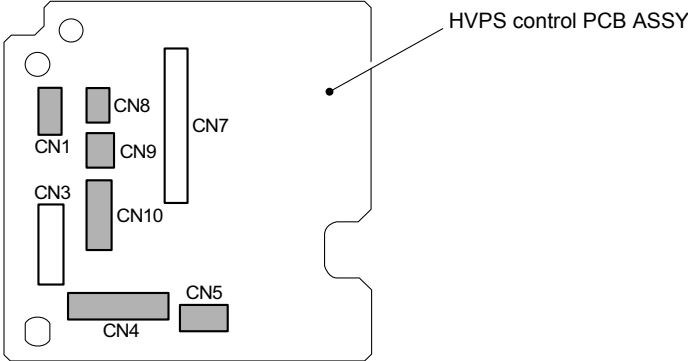

Fig. 5-191

- (2) Remove the Taptite pan (S/P W) B M3x10 screw, and then remove the HVPS control PCB ASSY from the Side frame R.

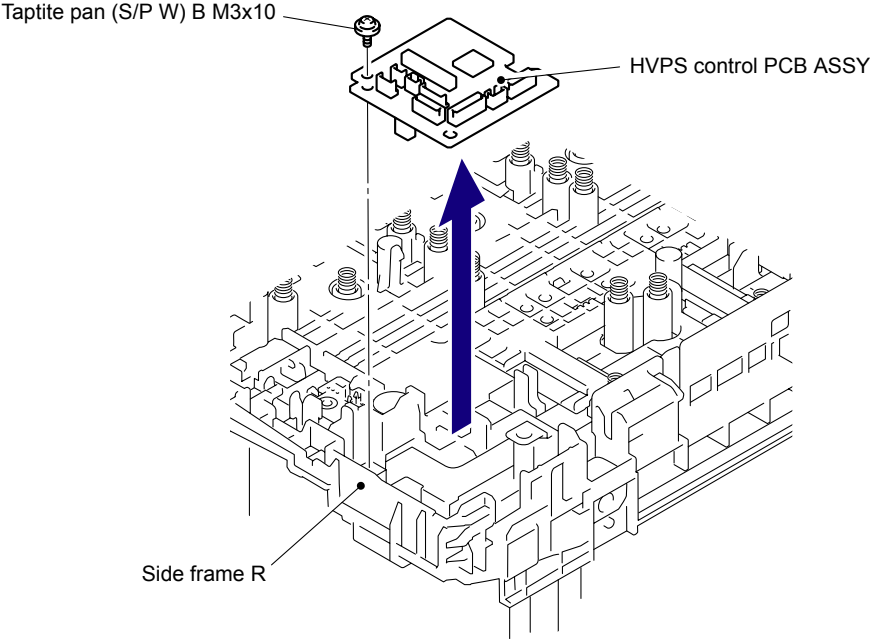

Fig. 5-192

# 8.61 Waste Toner Sensor

(1) Release the two Hooks to remove the Wire cover 2 from the Side frame R.

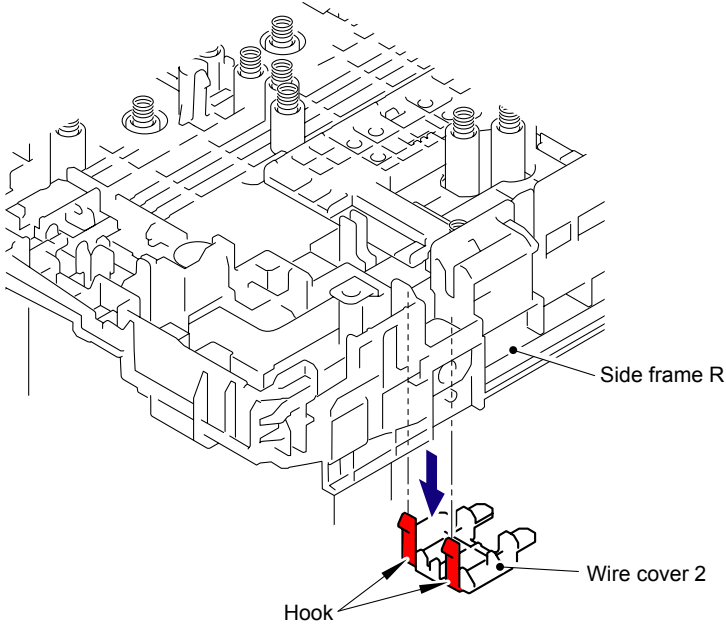

Fig. 5-193

**Assembling Note:**  
When assembling the Wire cover 2, make sure to pass the Waste toner harness ASSY through the "A" before assembling it.

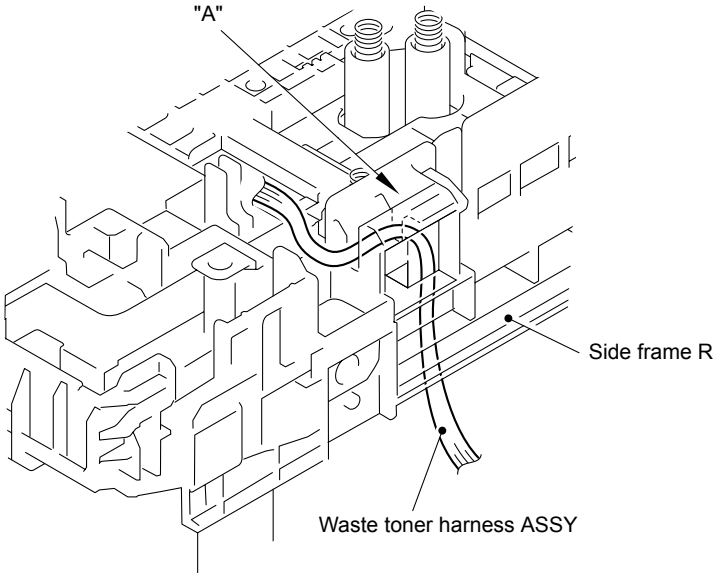

Fig. 5-194

- (2) Press the Pin of the Waste toner sensor holder and slide the Waste toner sensor holder to the left.

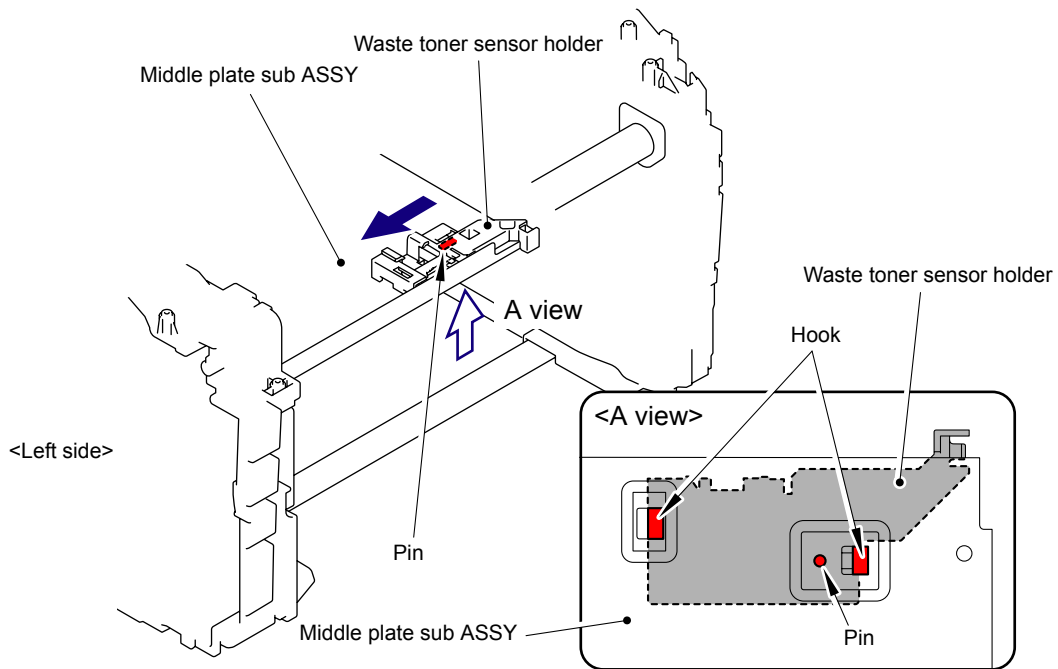

Fig. 5-195

- (3) Remove the Waste toner sensor holder from the Middle plate sub ASSY as shown in the figure below.

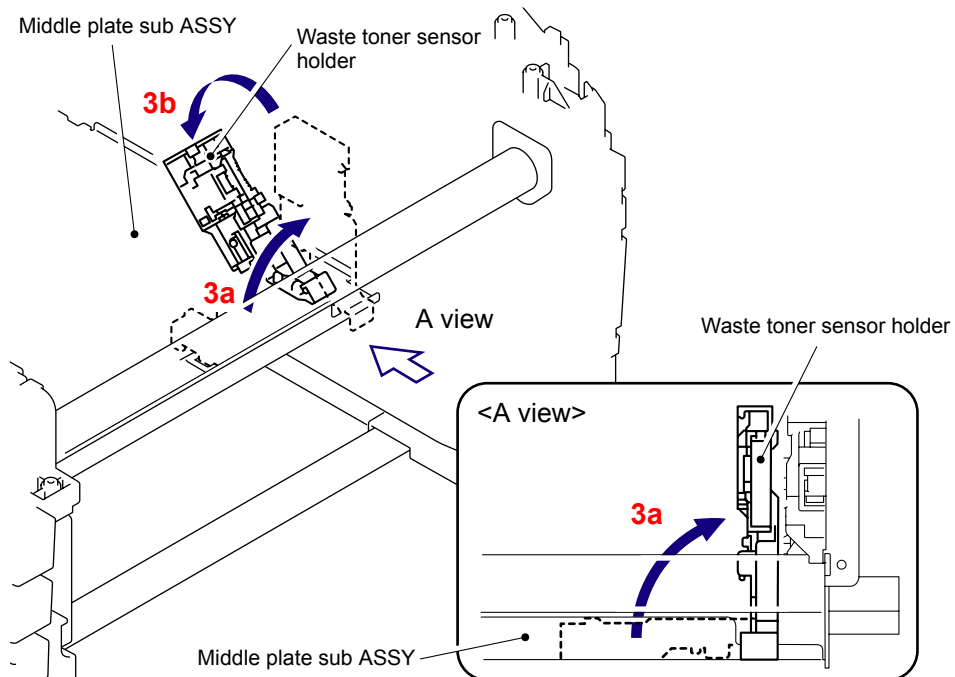
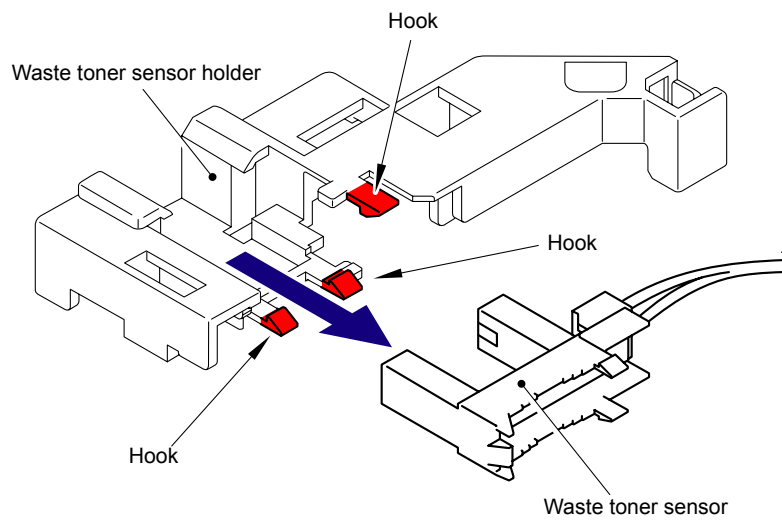

Fig. 5-196

- (4) Release the three Hooks to remove the Waste toner sensor from the Waste toner sensor holder.



**Fig. 5-197**

- (5) Disconnect the Connector of the Waste toner harness ASSY from the Waste toner sensor.

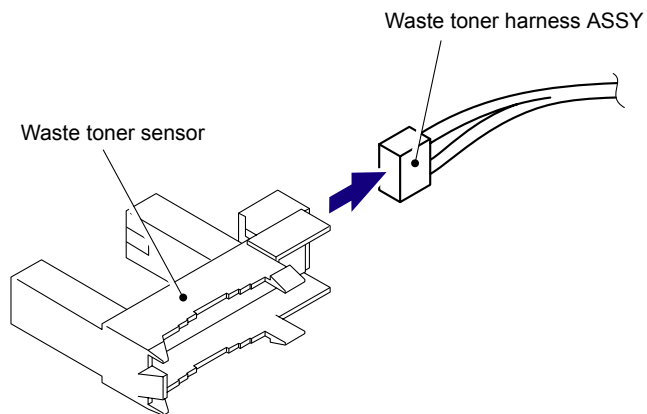

**Fig. 5-198**

**Harness routing:** Refer to "[16 Waste Toner Sensor.](#)"

# 8.62 Develop Release Sensor PCB ASSY

(1) Remove the Film from the Side frame R.

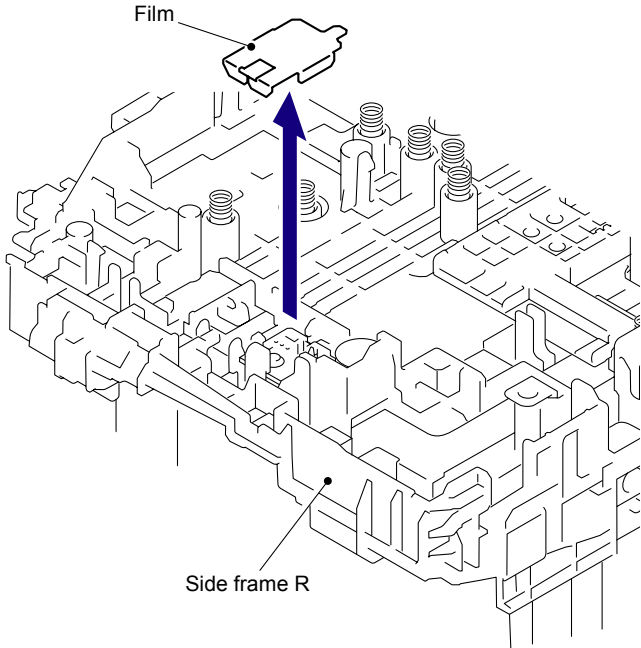

Fig. 5-199

(2) Remove the Taptite cup B M3x8 screw, and then release the Hook to remove the Develop release sensor PCB ASSY from the Side frame R.

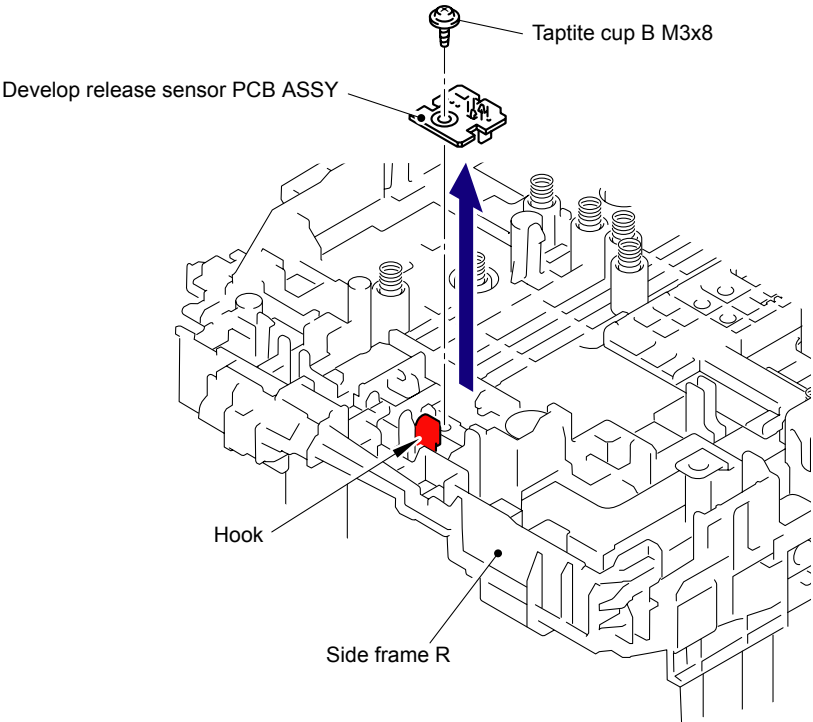

Fig. 5-200

**Harness routing:** Refer to "18 Develop Release Sensor PCB ASSY, Top Cover Open Switch, Toner LED PCB ASSY."

# 8.63 Belt Cleaner Spring

(1) Remove the four Electrode head 1 and four Electrode spring 1 from the Side frame R.

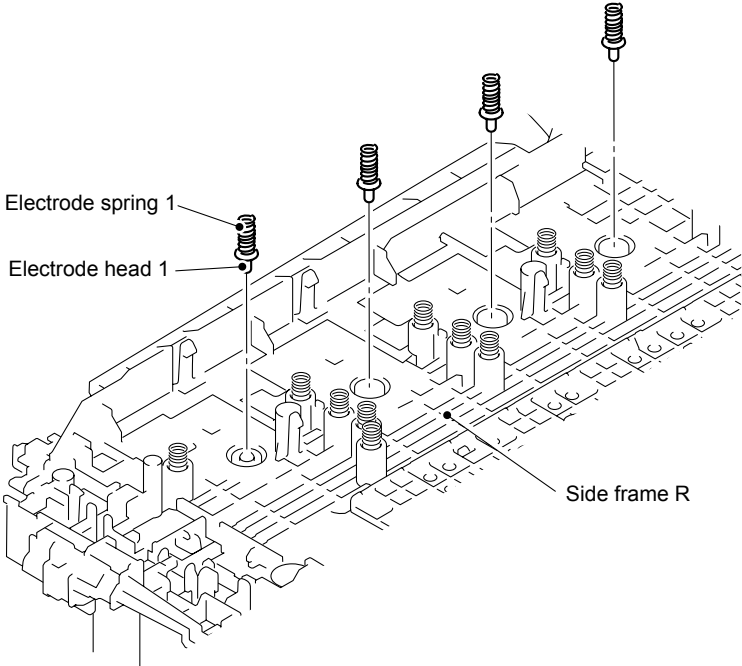

Fig. 5-201

(2) Remove the four Electrode spring 2 from the Side frame R.

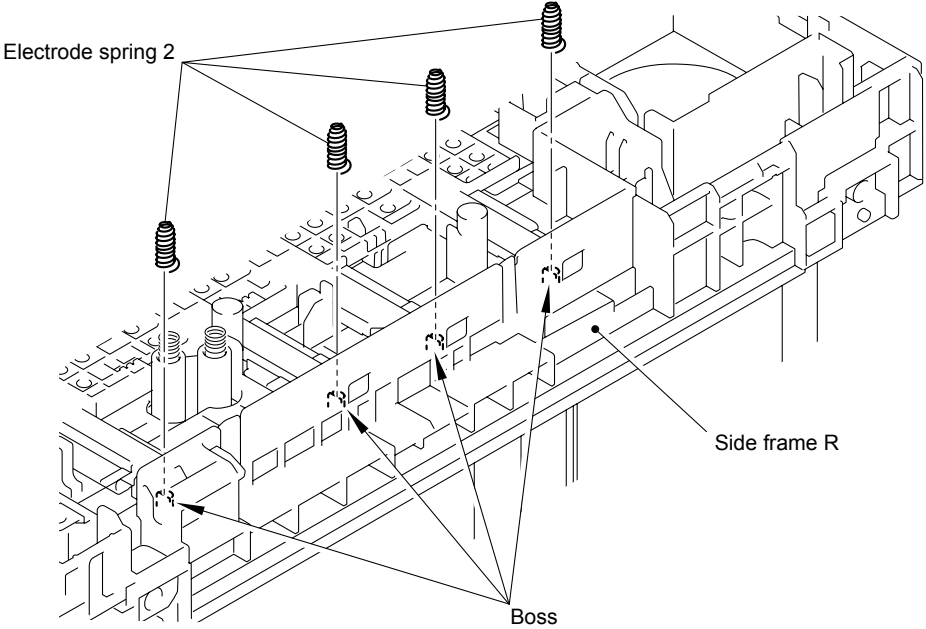
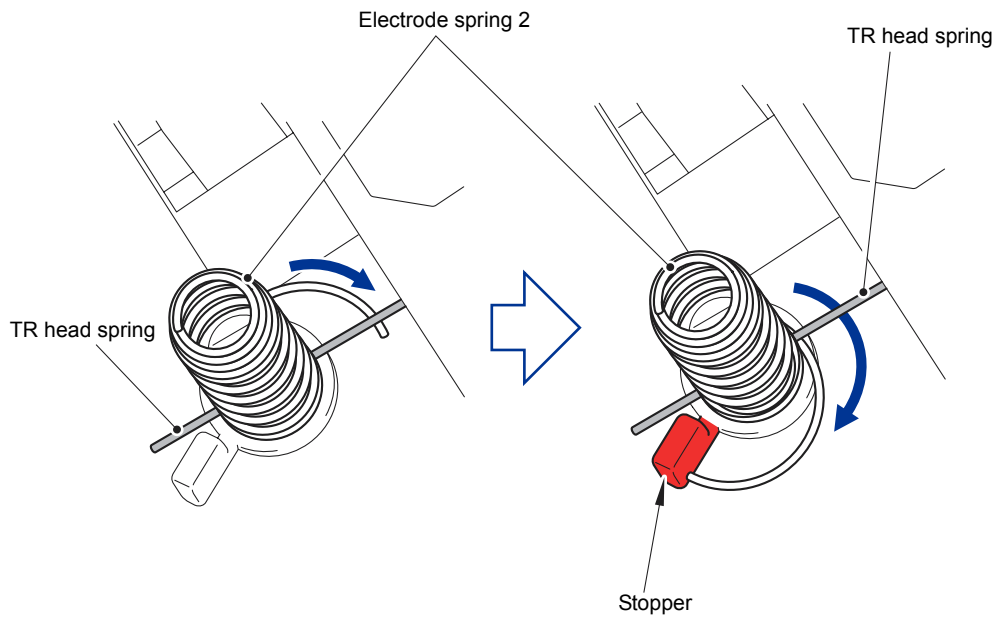

Fig. 5-202

**Assembling Note:**

When assembling the Electrode spring 2, make sure to insert the tip of the Spring under the TR head spring until it hits the Stopper as shown in the figure below.



**Fig. 5-203**

- (3) Remove the thirteen Electrode head 2 and thirteen Electrode spring 3 from the Side frame R.

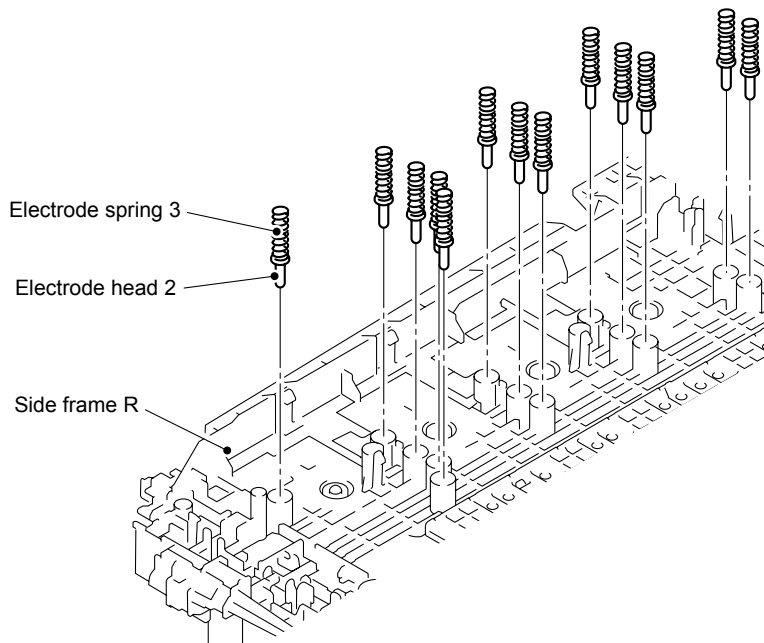

**Fig. 5-204**



- (4) Remove the two Electrode head 2 and two Belt cleaner spring from the Side frame R.

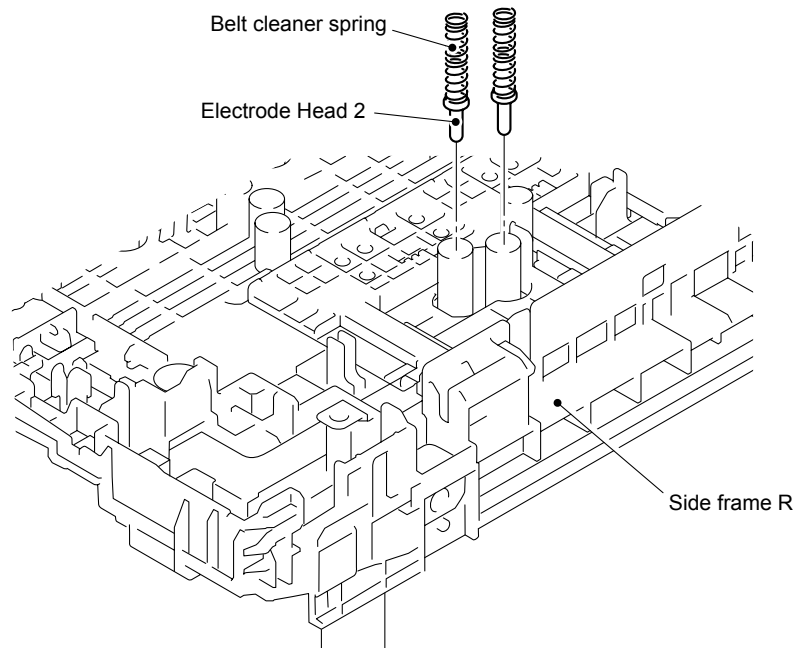

**Fig. 5-205**

- (5) Remove the two Belt cleaner springs from the two Electrode head 2.

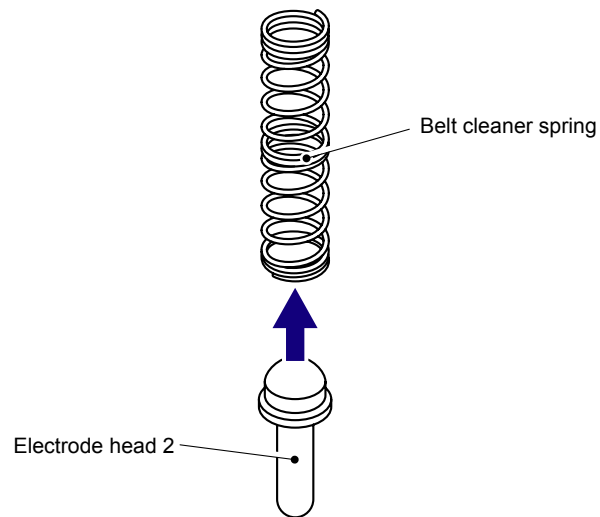

**Fig. 5-206**

**Memo:**

Although the following parts are similar in shape, you can identify them by size.

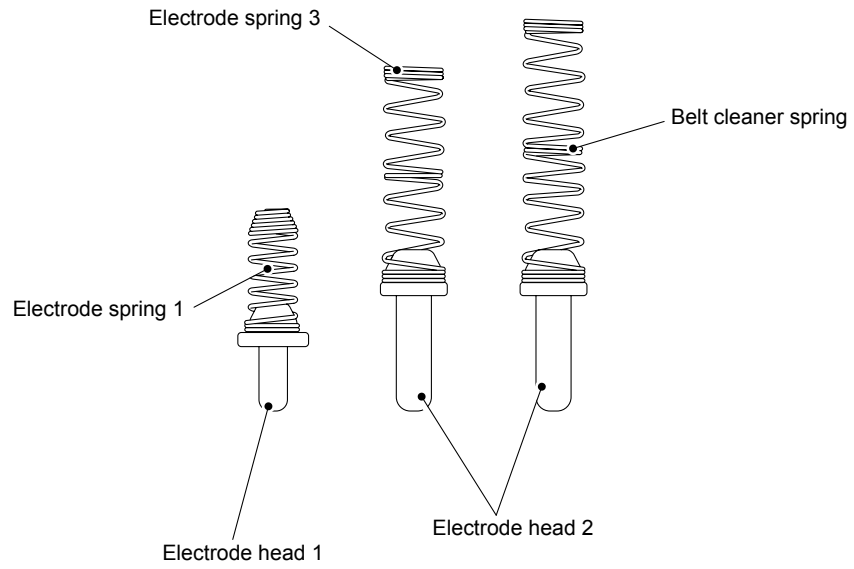

**Fig. 5-207**

# 8.64 TR Head Spring

- (1) Release the four Hooks, slide the TR head cover in the direction of the arrow 1a, and remove it from the Side frame R in the direction of the arrow 1b.

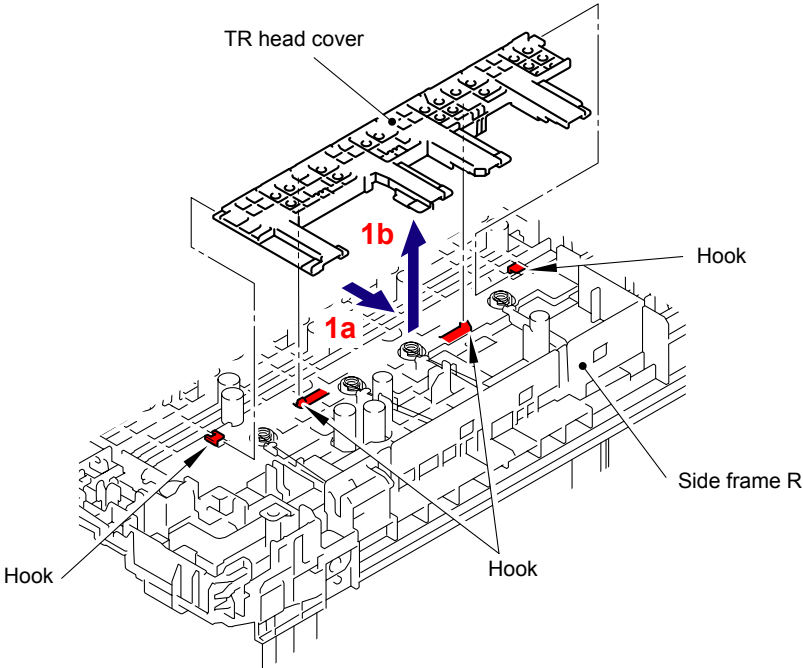

Fig. 5-208

- (2) Remove the four Electrode head 2 and four TR head spring from the Side frame R.

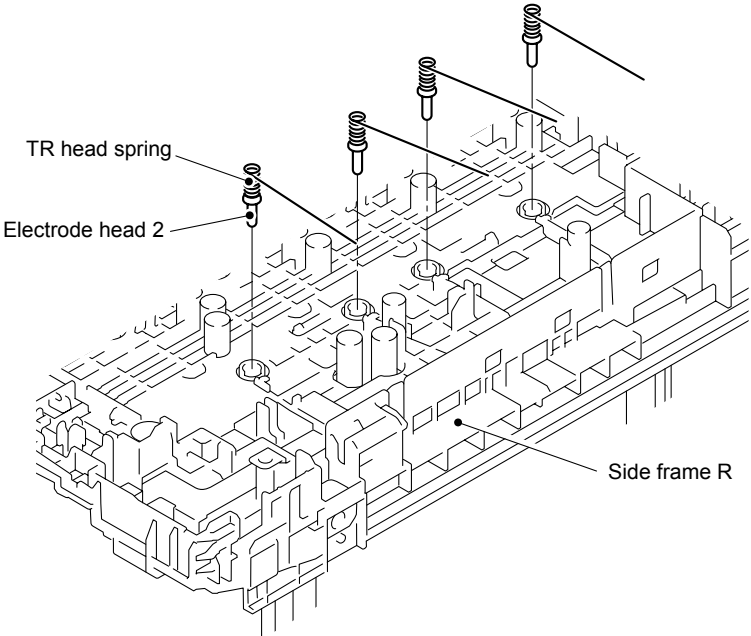
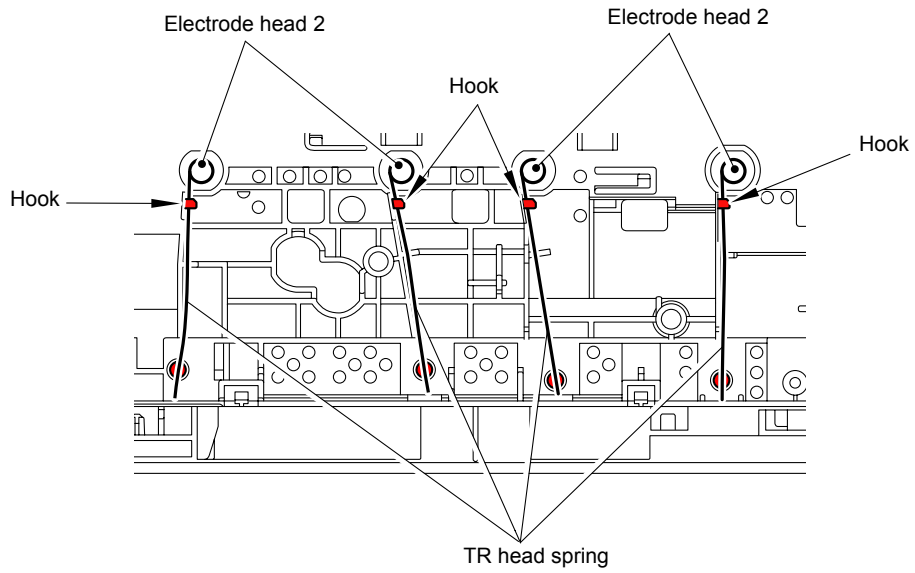

Fig. 5-209

**Assembling Note:**

When assembling the Electrode head 2 and TR head spring onto the Side frame R, make sure to assemble them as shown in the figure below.



**Fig. 5-210**

- (3) Remove the TR head spring from the four Electrode heads 2 (four springs in total).

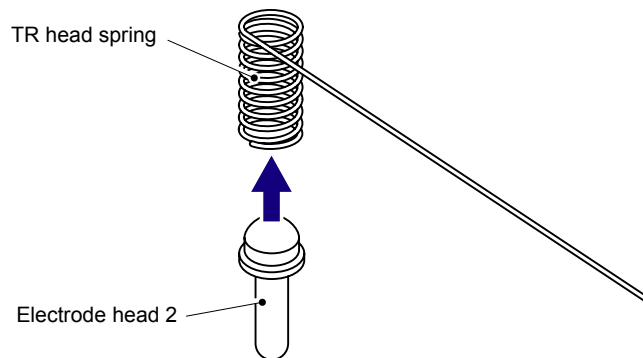

**Fig. 5-211**

# 8.65 Side Frame R

- (1) Remove the four Shoulder screws M3, and then remove the Side frame R from the Base frame unit.

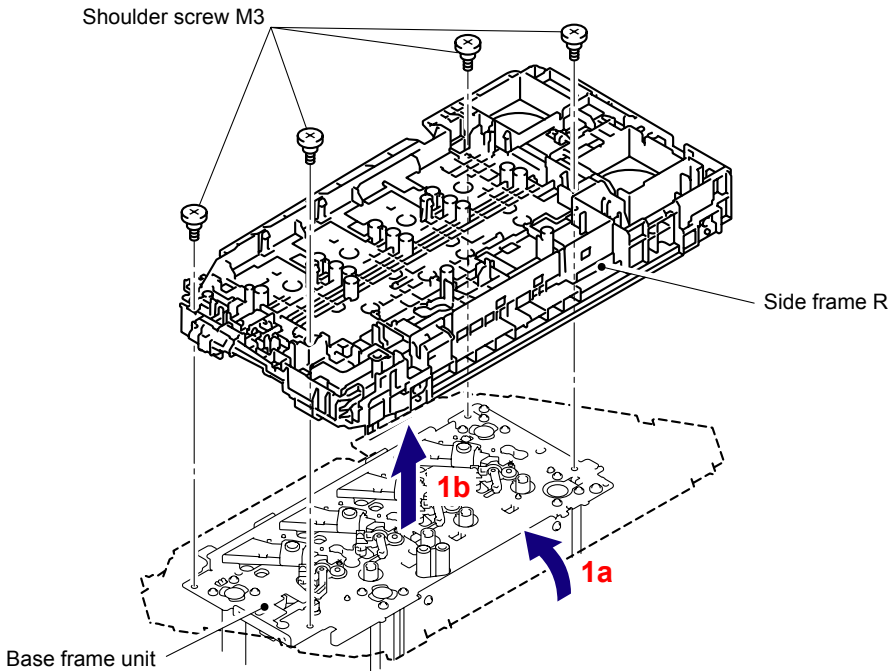

Fig. 5-212

- (2) Remove the HVPS ground plate 1 from the Side frame R.

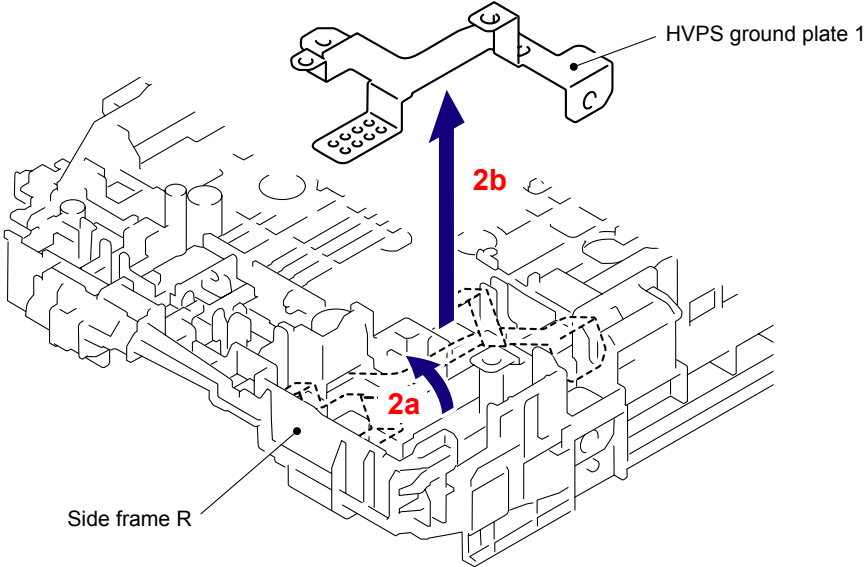

Fig. 5-213

- (3) Release the two Hooks of the Top cover open switch to remove the Top cover open switch from the Side frame R.

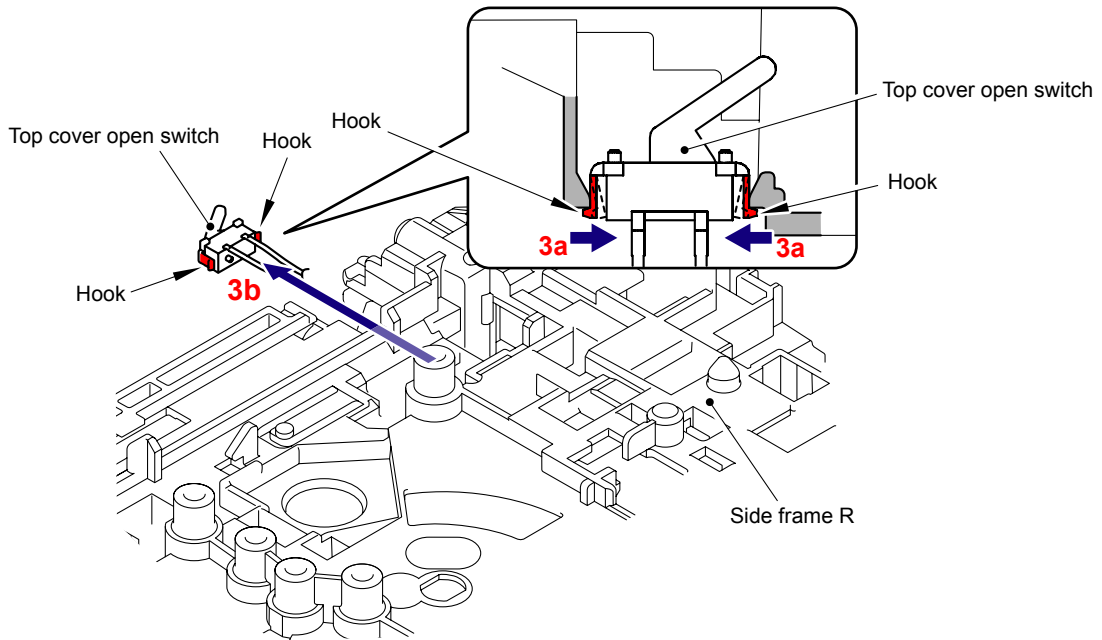

Fig. 5-214

**Harness routing:** Refer to “[18](#) Develop Release Sensor PCB ASSY, Top Cover Open Switch, Toner LED PCB ASSY.”

- (4) Release the Hook of the Lock arm from the Side frame R.

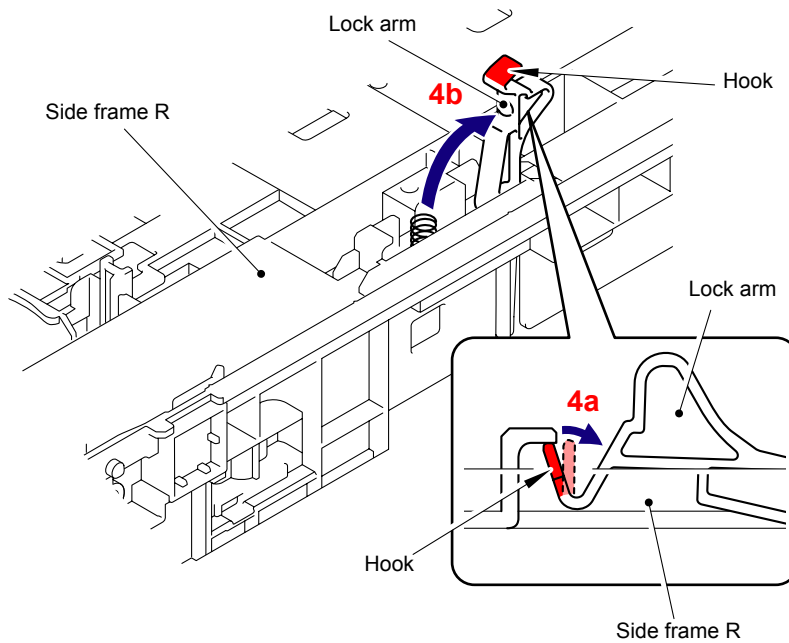
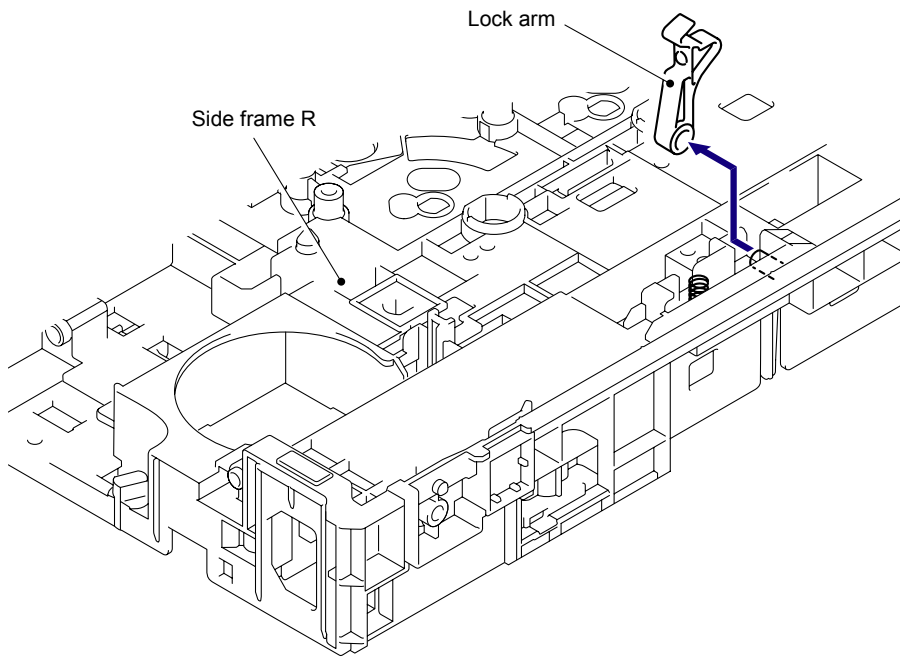

Fig. 5-215

- (5) Remove the Lock arm from the Side frame R.

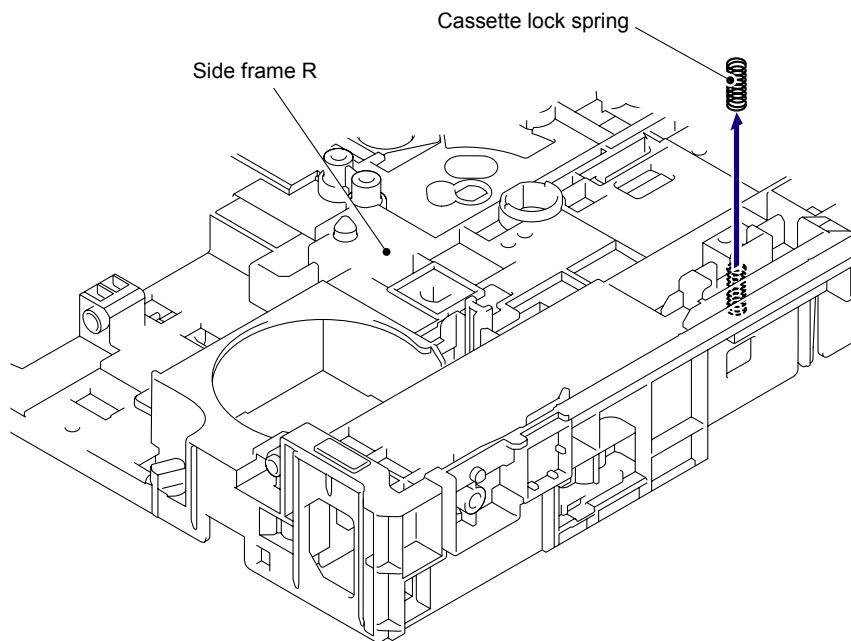

**Fig. 5-216**

- (6) Remove the Cassette lock spring from the Side frame R.

**Note:**

Be careful not to loose the Cassette lock spring.



**Fig. 5-217**

## 8.66 Toner LED PCB ASSY/LED Holder

- (1) Press the Pin of the Side frame R, slide the Toner LED PCB ASSY in the direction of the arrow 1b, and remove it.

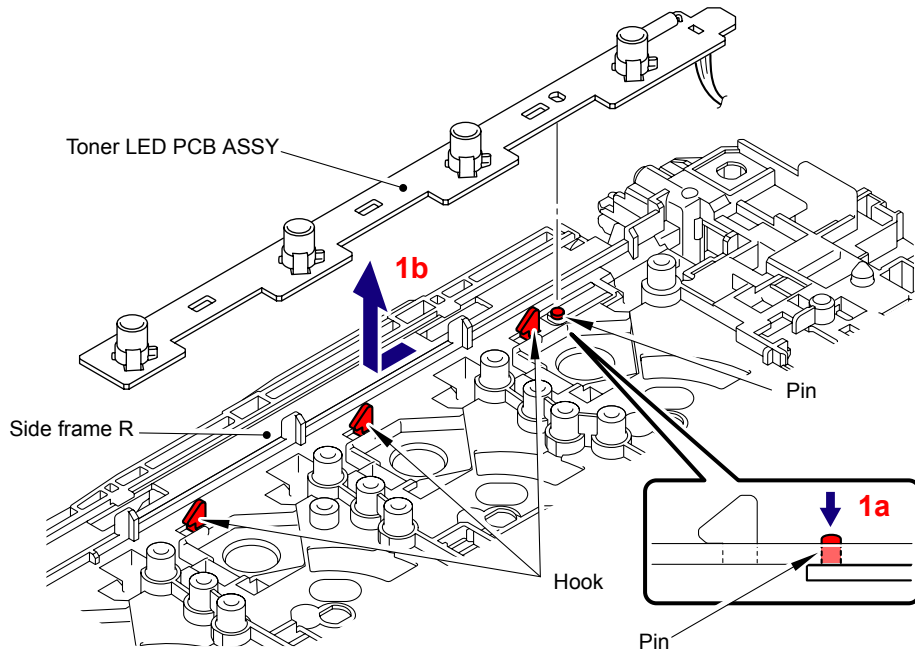

Fig. 5-218

- (2) Release the two Hooks to remove the four LED holder from the Toner LED PCB ASSY.

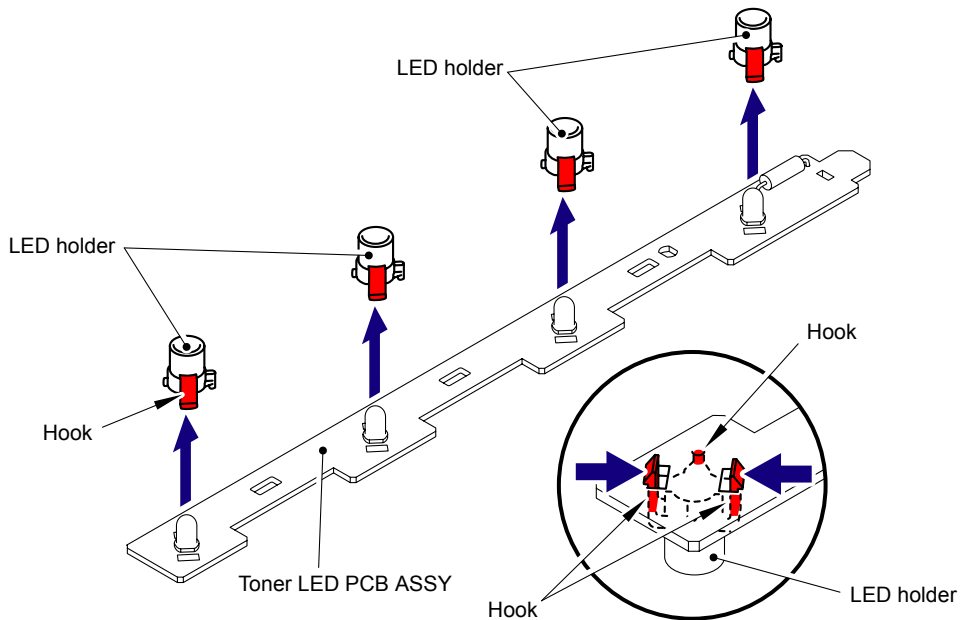

Fig. 5-219

**Harness routing:** Refer to "[18](#) Develop Release Sensor PCB ASSY, Top Cover Open Switch, Toner LED PCB ASSY."



## 8.67 LM Hook B/LM Hook C/Hook Spring BC10

**Note:**

Be sure to mount the eject gear cover and cleaner PF gear cover before turning over the side frame L.

- (1) Remove the three Shoulder screws M3 and one Taptite cup S M3x6 SR screw, and then remove the Side frame L from the Base frame unit.

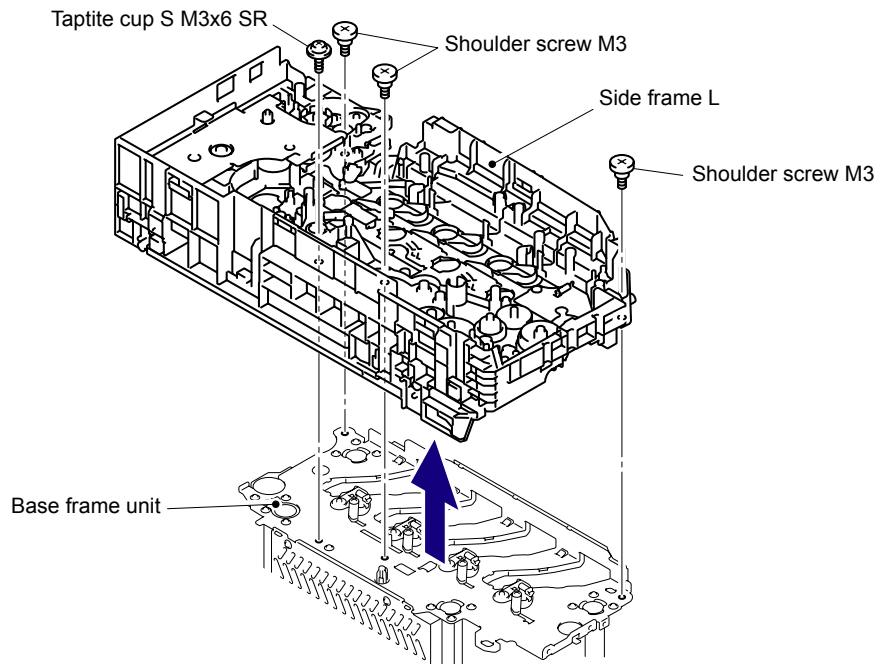

**Fig. 5-220**

- (2) Remove the three Taptite bind B M4x12 screws, and then remove the Bevel gear cover from the Side frame L.

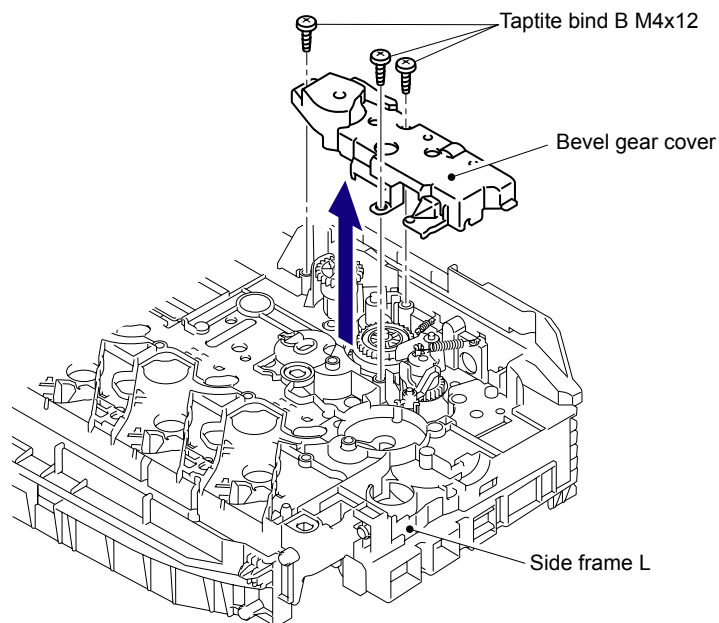

**Fig. 5-221**

(3) Remove the LM hook B and LM hook C from the Side frame L.

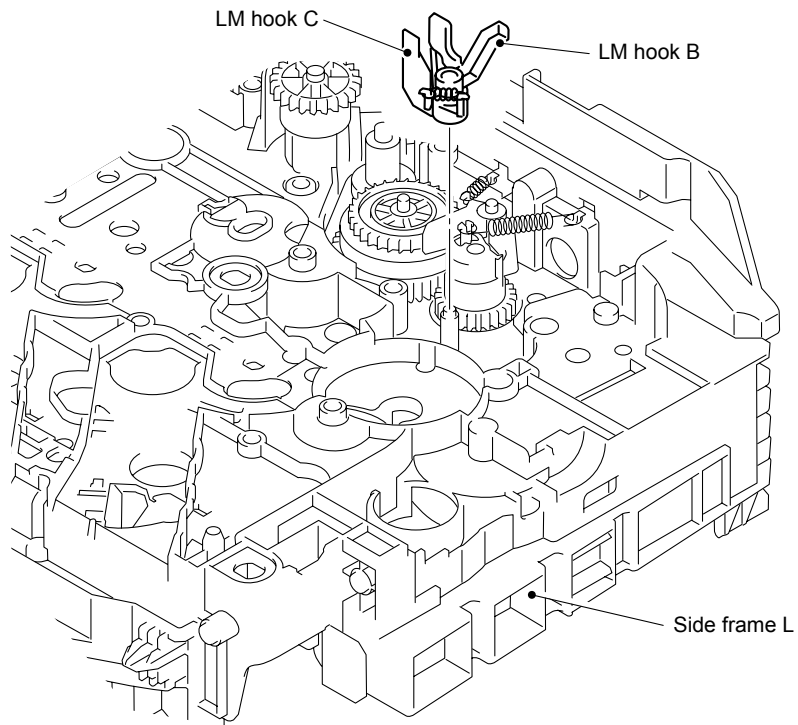

**Fig. 5-222**

(4) Remove the Hook spring BC10 from the LM hook B and the LM hook C.

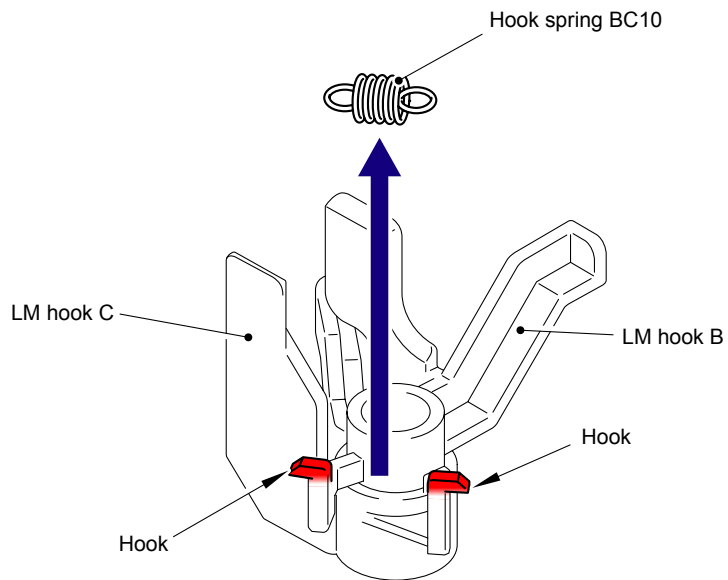

**Fig. 5-223**

(5) Remove the LM hook B from the LM hook C.

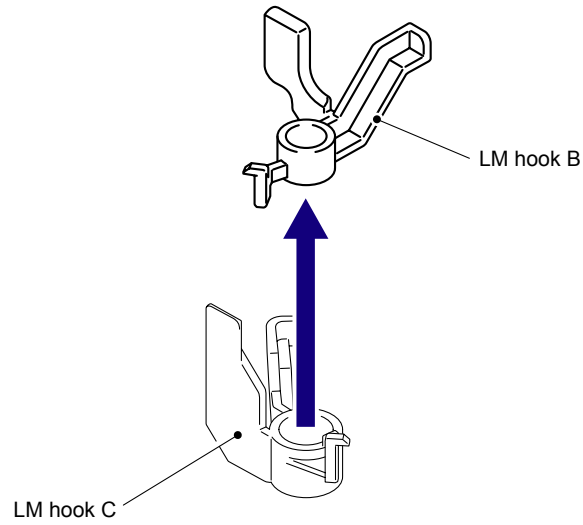

**Fig. 5-224**

(6) Remove the Hook spring BC10 from the LM hook A and the Side frame L.

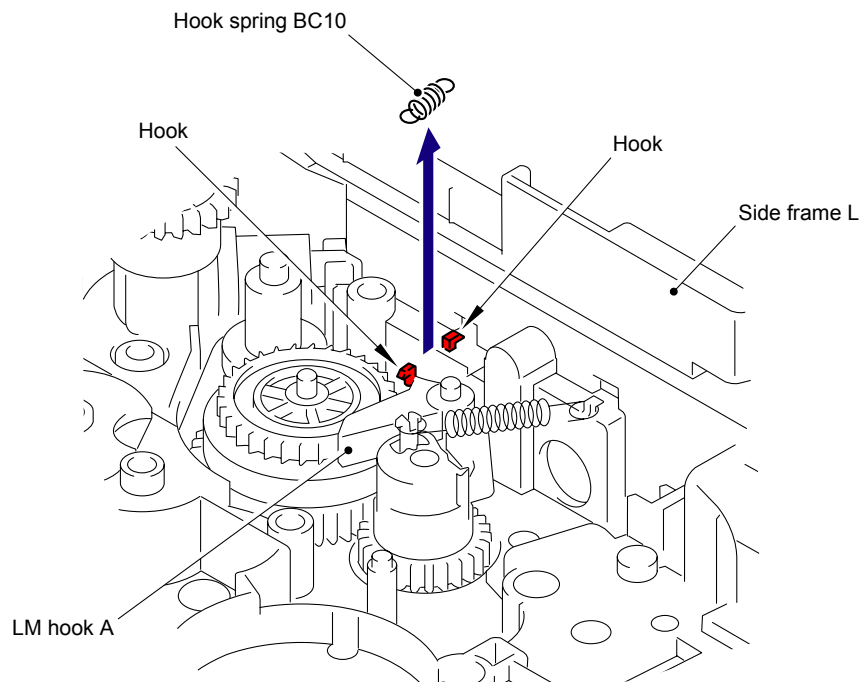

**Fig. 5-225**

# **CHAPTER 6**

## **ADJUSTMENTS AND UPDATING OF SETTINGS, REQUIRED AFTER PARTS REPLACEMENT**

# CHAPTER 6

## ADJUSTMENTS AND UPDATING OF SETTINGS, REQUIRED AFTER PARTS REPLACEMENT

This chapter describes adjustments and updating of settings, which are required if the main PCB and some other parts have been replaced. This chapter also covers how to update the firmware.

### CONTENTS

<b>1. IF YOU REPLACE THE MAIN PCB.....</b>	<b>6-1</b>
1.1 Rewriting the Firmware (Main Firmware, Sub Firmware (GDI or PCL/PS)) .....	6-7
1.1.1 Checking firmware version .....	6-7
1.1.2 Rewriting the firmware using computer .....	6-7
1.1.3 Rewriting the firmware using USB flash memory (HL-3070CW only) .....	6-9
1.2 Setting by Country (Maintenance Mode: Code 74) .....	6-11
1.3 Initialization of EEPROM of Main PCB (Maintenance Mode: Code 01).....	6-11
1.4 Setting the Serial Number .....	6-11
1.5 Sensitivity Adjustment of Density Sensor (Maintenance Mode: Code 72).....	6-12
1.6 Performing the Developing Bias Voltage Correction (Maintenance Mode: Code 83) .....	6-12
1.7 Performing the Adjustment of Color Registration (Maintenance Mode: Code 66)....	6-12
1.8 Operational Check of Control Panel Button (Maintenance Mode: Code 13) .....	6-12
1.9 Acquiring MAC Address (Ethernet Address) from Wireless LAN PCB (HL-3070CW only).....	6-12
<b>2. IF YOU REPLACE THE WIRELESS LAN PCB (HL-3070CW ONLY).....</b>	<b>6-13</b>
2.1 Acquiring MAC Address (Ethernet Address) from Main PCB .....	6-13
<b>3. IF YOU REPLACE THE REGISTRATION SENSOR HOLDER ASSY ....</b>	<b>6-14</b>
3.1 Sensitivity Adjustment of Density Sensor (Maintenance Mode: Code 72).....	6-14

# 1. IF YOU REPLACE THE MAIN PCB

## ■ What to do when replacing the main PCB

- Rewriting the firmware (Main firmware, sub firmware (GDI or PCL/PS))
- Setting by country (Maintenance mode: code 74)
- Initialization of EEPROM of main PCB (Maintenance mode: code 01)
- Setting the serial number
- Sensitivity adjustment of density sensor (Maintenance mode: code 72)
- Performing the developing bias voltage correction (Maintenance mode: code 83)
- Performing the adjustment of color registration (Maintenance mode: code 66)
- Operational check of control panel button (Maintenance mode: code 13)
- Acquiring MAC address (ethernet address) from wireless LAN PCB (HL-3070CW only)

## ■ Which parts to use

Main PCB: The table below shows the ROM type.

Main PCB (For a spare parts)	ROM 0	Main firmware (Controller program, Network program)
	ROM 1	Sub firmware HL-3040CN: GD I HL-3070CW: PCL/PS

## ■ What you need to prepare

- (1) A USB cable
- (2) A USB flash memory drive (HL-3070CW only)
- (3) Computer (Windows® XP/2000 or later)  
Create a "hl3000" folder on the C drive, for example.
- (4) The maintenance tool (brmainte.zip)  
Copy it into the "hl3000" folder that has been created in the C drive. Extract the copied file and run "brmainte.exe" file by double-clicking it.
- (5) The download utility (FILEDG32.EXE)  
Copy it into the "hl3000" folder that has been created in the C drive.
- (6) The Brother maintenance USB printer driver (MaintenanceDriver.zip)  
Copy it into the "hl3000" folder that has been created in the C drive. Extract the copied file.
- (7) The firmware

Main firmware		LZXXXX_\$.djf or LZXXXX_\$.upd*
Sub firmware	HL-3040CN: GDI	LZXXXX_\$.upd
	HL-3070CW: PCL/PS	LZXXXX_\$.djf or LZXXXX_\$.upd
LZXXXX: First six digits are a parts number of the firmware. \$: Alphabet representing the revision of the firmware.		

\* upd: Used to rewrite the firmware via a computer.

djf: Used to rewrite the firmware using a USB flash memory. (HL-3070CW only)

(8) Installing the maintenance driver

To identify multiple machines connected to the computer via USB, the computer needs to configure the corresponding number of virtual USB devices by a driver or software. If you connect a multiple number of machines to your computer, the same number of virtual USB devices will be automatically configured on your computer.

To prevent virtual USB devices from being configured without limitation, use the unique driver installation procedure described below that enables your computer to identify multiple machines via one single virtual USB device.

<Procedures>

- 1) While the machine is in the ready state, press the **OK** button and then **Go** button. Next, press the **▲** button 4 times, and the machine goes into the maintenance mode.
- 2) “■■ MAINTENANCE ■■” appears on the LCD, and the machine goes into the maintenance mode.
- 3) Double-click “Setup.exe” of the maintenance printer driver which is saved in the “hl3000” folder to execute.
- 4) The following screen appears, indicating the detection of device driver installation wizard. Click **Next** to proceed. (Screen below is the example of Windows® XP.)



- 5) Alert warning message appears three times, click **Continue Anyway** to proceed.

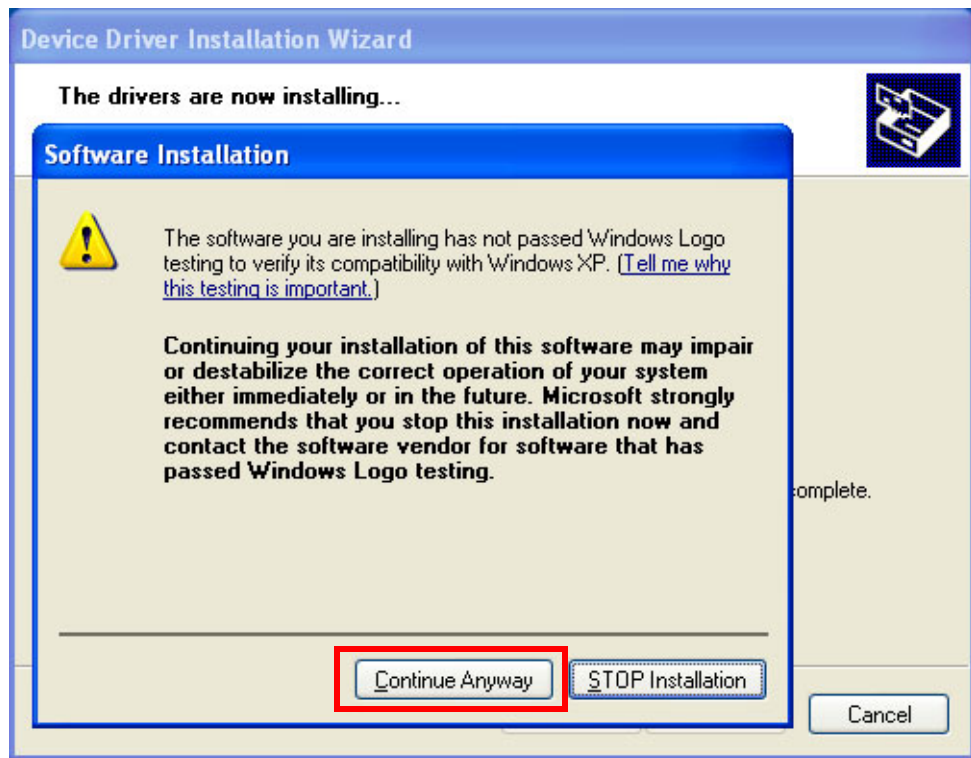

- 6) If the device driver is successfully installed, the following message screen appears. Click **Finish** to return.





- 7) Connect the machine to your computer using the USB cable.
- 8) The following screen appears, indicating the detection of new hardware device by the system. Select “No, not this time” and click **Next**.

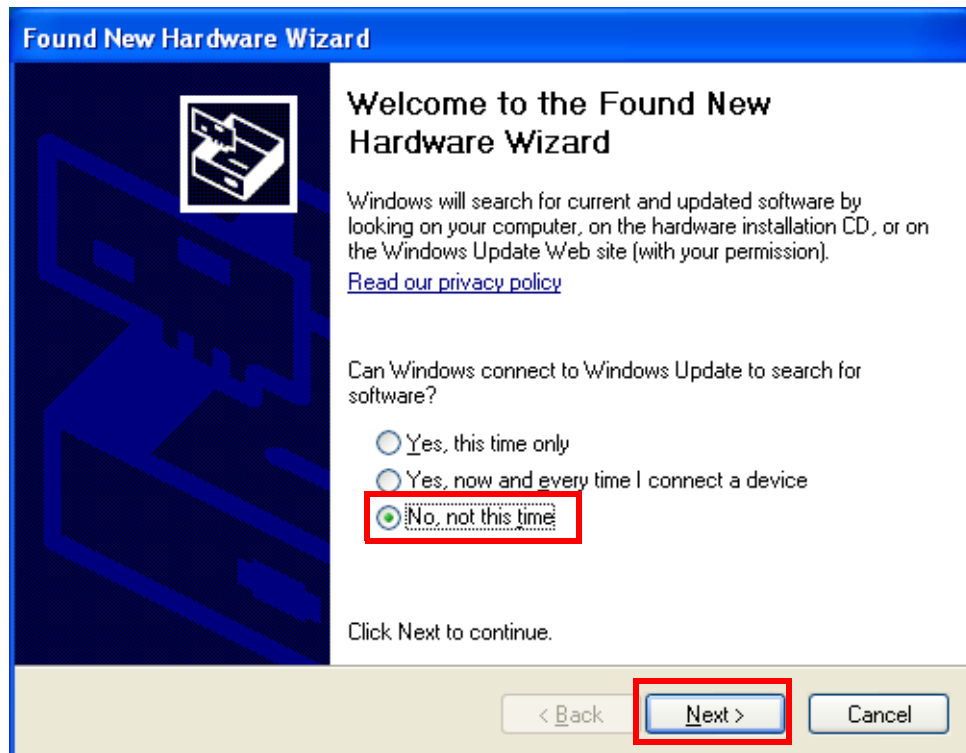

- 9) Select “Install the software automatically (Recommended)” and click **Next**.

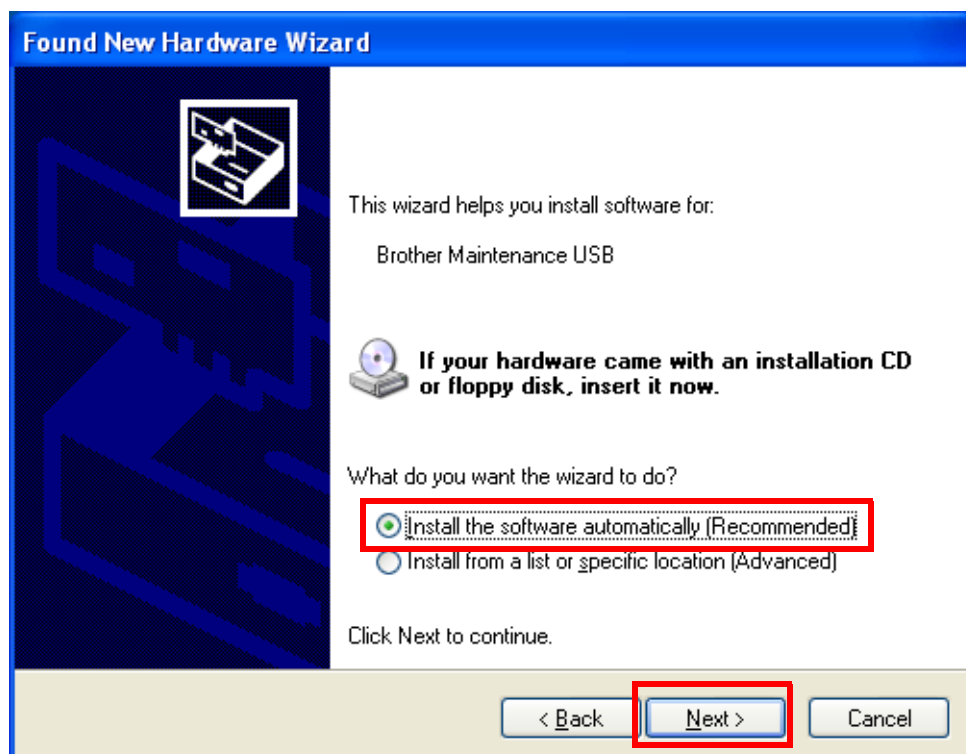

10) Alert warning message appears, click **Continue Anyway** to proceed.

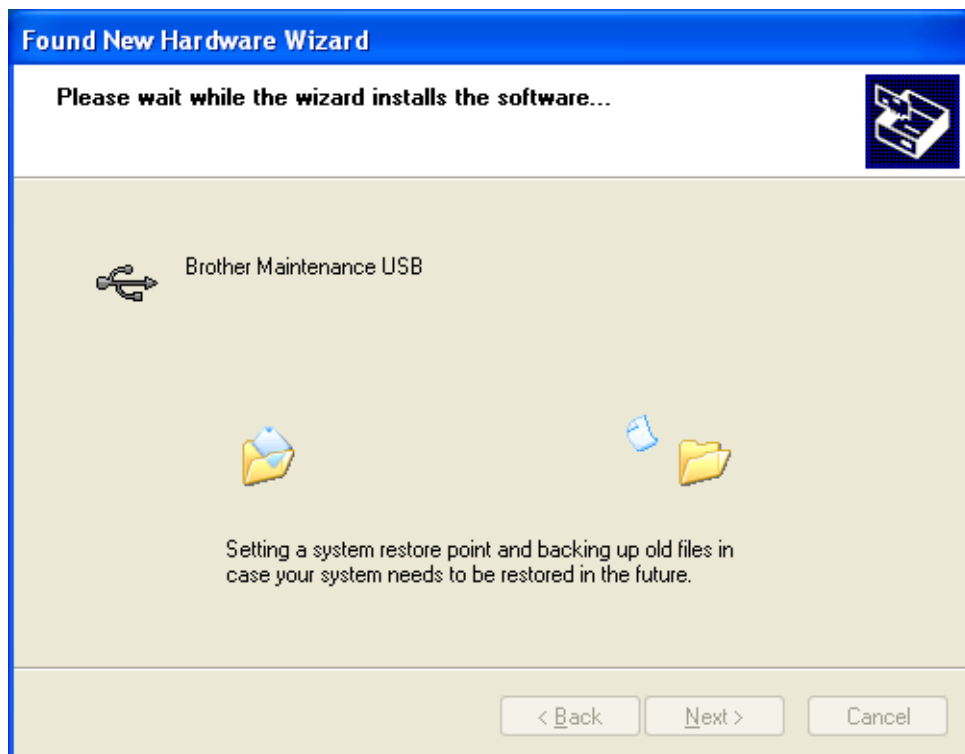

- 11) If the Brother maintenance USB printer driver is successfully installed, the following message screen appears. Click **Finish** to return.

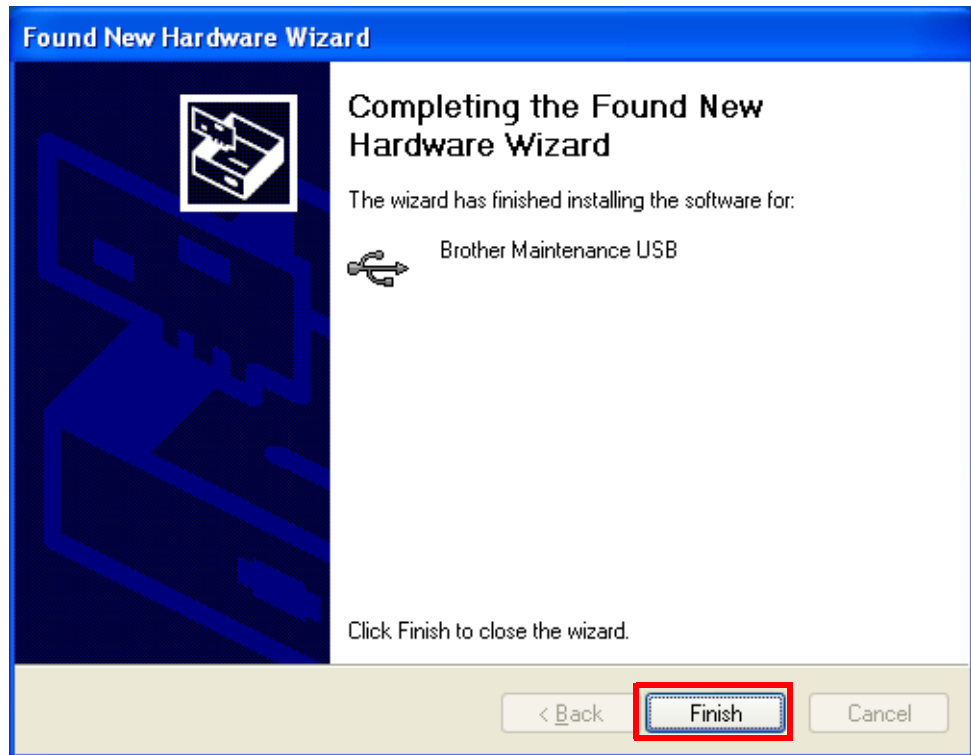

- 12) Repeat the steps from 9) to 11) three times, and then complete its installation.

# 1.1 Rewriting the Firmware (Main Firmware, Sub Firmware (GDI or PCL/PS))

The following two methods are available for rewriting the firmware (Main firmware and Sub firmware (GDI or PCL/PS)).

- Rewriting using a computer
- Rewriting using USB flash memory (USB host model only)

## 1.1.1 Checking firmware version

Check if the firmware written on the main PCB is the latest version or not. If it is the latest version, there is no need to write the firmware. If it is not, make sure to write the firmware to the main PCB in accordance with “1.1.2. Rewriting the firmware using computer” or “1.1.3 Rewriting the firmware using USB flash memory (HL-3070CW only)” in this chapter.

### <How to check firmware version>

- (1) Press the ▲ or ▼ button in the initial state of the maintenance mode to display “MAINTENANCE 25” and press the **OK** button. Then, the firmware version information is displayed on the LCD.

## 1.1.2 Rewriting the firmware using computer

The following firmware files are needed to rewrite the firmware.

Sub firmware	HL-3040CN: GDI	LZXXXX_\$.upd
	HL-3070CW: PCL/PS	LZXXXX_\$.upd
Main firmware		LZXXXX_\$.upd
LZXXXX: First six digits are a parts number of the firmware. \$: Alphabet representing the revision of the firmware.		

### Note:

- It is recommendable to rewrite 1) Sub firmware (GDI or PCL/PS) and 2) Main firmware in this order.
- DO NOT unplug the power cord of the machine or your computer or disconnect the USB cable while rewriting the program files.

### <Procedures>

- (1) Turn the power switch of the machine off. Then, turn it on while pressing the **Go** and **Cancel** buttons at the same time. Check that “■■■■■■■■” appears on the LCD.
- (2) Double-click the “FILEDGD32.EXE” to start. The following screen appears. Select the “Brother Maintenance USB Printer.”

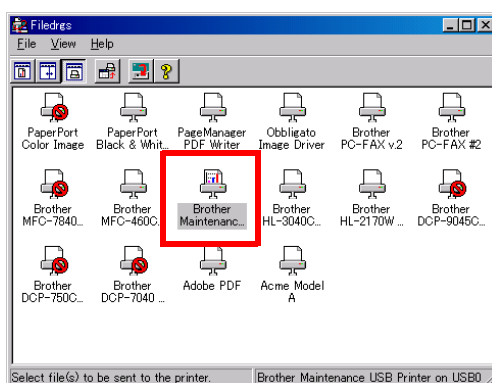

- (3) Click the “Brother Maintenance USB Printer” icon to select. Drag the necessary firmware program file such as LZXXXX\_\$.upd and drop it.

**Note:**

After rewriting Sub firmware (GDI or PCL/PS) or Main firmware is completed, the machine returns to the ready state. To continue rewriting the other program files, turn off the power switch of the machine, and turn it on again while pressing the **Go** and **Cancel** buttons at the same time. Check that “■■■■■■■■” appears on the LCD and start rewriting.

- (4) Upon completion of rewriting, the machine restarts and returns to the ready state automatically.

### 1.1.3 Rewriting the firmware using USB flash memory (HL-3070CW only)

If you save the program files in the USB flash memory drive and plug it into the USB direct interface, you can rewrite the firmware.

When a USB flash memory is used, the following firmware files are needed to rewrite the firmware.

Sub firmware (PCL/PS)	LZXXXX_\$.djf
Main firmware	LZXXXX_\$.djf
LZXXXX: First six digits are a parts number of the firmware. \$: Alphabet representing the revision of the firmware.	

#### Note:

- Make sure that the USB flash memory drive has enough space to save the program file.
- It is recommendable to rewrite 1) Sub firmware (PCL/PS) and 2) Main firmware in this order.
- If rewriting the firmware using a USB flash memory fails and an error message appears on the LCD, or no message appears on the LCD, it will be necessary to rewrite the firmware from a computer using the "FILEDG32.EXE." (Refer to "1.1.2 Rewriting the firmware using computer" in this chapter.)

#### <Procedures>

- (1) Save the program files (such as LZXXXX\_\$.djf) which are necessary for rewriting the firmware that prepared in the "hl3000" folder to the USB flash memory.
- (2) While the machine is in the ready state, connect the USB flash memory drive to the USB direct interface on the front of the machine.

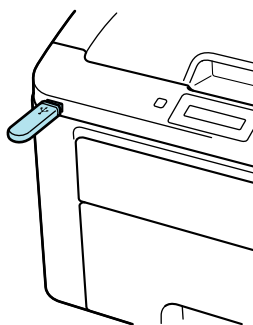

Fig. 6-1

- (3) When the machine recognizes the USB flash memory, the names of the files stored in the USB flash memory are displayed. Select an appropriate file using the ▲ or ▼ button, and then press the **Go** or **OK** button.

#### Memo:

To print and check the list of data stored in the USB flash memory, display the LCD, select "Index Print" using the ▲ or ▼ button, and then press the **Go** or **OK** button.

- (4) "Program Update/Press Go" appears on the LCD. Press the **Go** or **OK** button to start. "Program Updating/Do not turn OFF" message appears on the LCD with Data LED blinking while rewriting the firmware. DO NOT turn off the machine.
- (5) When the rewrite is finished, the machine automatically restarts.

- (6) If you continue to rewrite other firmware and no file names are displayed, wait for a while, and take out the USB flash memory and insert it again. When file names are displayed, select the program files which need to be rewritten, and repeat the above procedures (3) to (5) to rewrite all the selected program files.
- (7) When the rewrite of the main firmware is finished, the machine automatically restarts.
- (8) Remove the USB flash memory drive from the USB direct interface once the update have finished.
- (9) Next, make the settings according to the country. (Refer to [“1.4.16 Setting by country”](#) in [Chapter 7.](#))

**Memo:**

You can check the firmware version of the Main firmware and the Sub firmware (GDI or PCL/PS) by printing the Printer Settings. (Refer to [“2.4 Print out of Printer Settings”](#) in [Chapter 7.](#))

## 1.2 Setting by Country (Maintenance Mode: Code 74)

Make appropriate settings by country in accordance with “1.4.16 Setting by country” in Chapter 7.

## 1.3 Initialization of EEPROM of Main PCB (Maintenance Mode: Code 01)

Initialize the EEPROM in accordance with “1.4.1 EEPROM parameter initialization” in Chapter 7.

## 1.4 Setting the Serial Number

### <Procedures>

- (1) Check that the machine is in the initial state of the maintenance mode, connect the computer to the machine with the USB cable.
- (2) Double-click the “brmainte.exe” file (maintenance utility) which has been copied in the “hl3000” folder to start.
- (3) Select “Input information” from Menu.

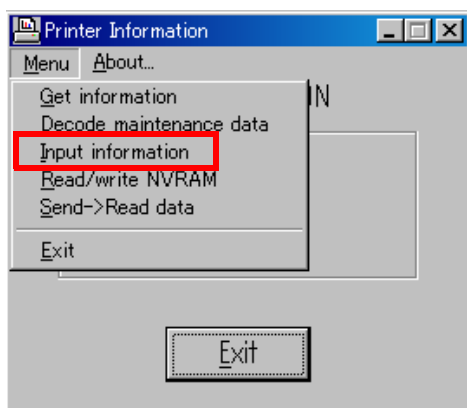

- (4) Select the applicable model name.
- (5) Check the port (USB) that the machine is connected through.
- (6) Click “Serial No.” in the lower box. Enter the serial number (the last nine digits) of the machine into the box on the right hand side and click the **OK** button.

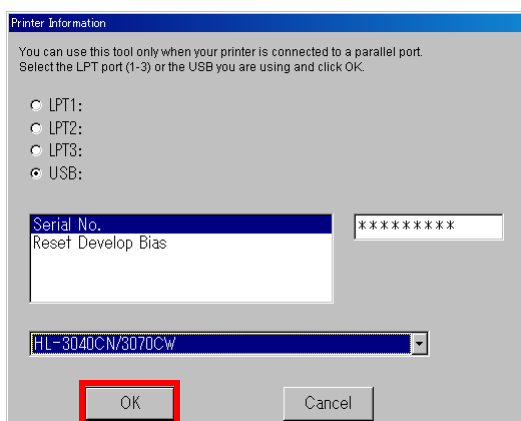

A confirmation window opens and shows the serial number. Check that it is correct and click the **OK** button.

### Memo:

Refer to [APPENDIX 3](#) to know how to read the serial number of the machine.



## **1.5 Sensitivity Adjustment of Density Sensor (Maintenance Mode: Code 72)**

Make sensitivity adjustments of the density sensor in accordance with “1.4.15 Sensitivity adjustment of density sensor” in Chapter 7.

## **1.6 Performing the Developing Bias Voltage Correction (Maintenance Mode: Code 83)**

Perform developing bias voltage correction in accordance with “1.4.21 Developing bias voltage correction” in Chapter 7.

## **1.7 Performing the Adjustment of Color Registration (Maintenance Mode: Code 66)**

Perform adjustment of color registration in accordance with “1.4.10 Adjustment of color registration” in Chapter 7.

## **1.8 Operational Check of Control Panel Button (Maintenance Mode: Code 13)**

Check performance of the panel button in accordance with “1.4.5 Operational check of control panel button” in Chapter 7.

## **1.9 Acquiring MAC Address (Ethernet Address) from Wireless LAN PCB (HL-3070CW only)**

### **<Procedures>**

- (1) Turn ON the power as holding down the ▲ button and OK button at the same time. Keep holding down the ▲ button and OK buttons until “Check start” appears.
- (2) When the MAC address (Ethernet address) is acquired from the wireless LAN PCB, “W Lan Module OK” is displayed on the LCD.
- (3) Turn OFF the power.

## 2. IF YOU REPLACE THE WIRELESS LAN PCB (HL-3070CW ONLY)

---

### ■ What to do when replacing the wireless LAN PCB

Obtaining the MAC Address (Ethernet Address)

### 2.1 Acquiring MAC Address (Ethernet Address) from Main PCB

#### <Procedures>

- (1) Turn ON the power as holding down the ▲ button and **OK** buttons at the same time. Keep holding down the ▲ button and **OK** buttons until "Check start" appears.
- (2) When the MAC address (Ethernet address) is acquired from the main PCB, "W Lan Module OK" is displayed on the LCD.
- (3) Turn OFF the power.

## 3. IF YOU REPLACE THE REGISTRATION SENSOR HOLDER ASSY

---

### ■ What to do when replacing the registration sensor holder ASSY

Sensitivity Adjustment of Density Sensor (Maintenance Mode: Code 72)

### 3.1 Sensitivity Adjustment of Density Sensor (Maintenance Mode: Code 72)

Make adjustments of the density sensor in accordance with "1.4.15 Sensitivity adjustment of density sensor" in Chapter 7.

# **CHAPTER 7**

## **SERVICE FUNCTIONS**

# CHAPTER 7

## SERVICE FUNCTIONS

Describes the maintenance mode which is exclusively designed for the purpose of checking the settings and adjustments using the buttons on the control panel.

This chapter also covers not-disclosed-to-users function menus, which activate settings and functions or reset the parts life.

### CONTENTS

<b>1. MAINTENANCE MODE.....</b>	<b>7-1</b>
1.1 How to Enter the Maintenance Mode .....	7-1
1.2 How to Enter the End User-accessible Maintenance Mode .....	7-1
1.3 List of Maintenance-mode Functions.....	7-2
1.4 Detailed Description of Maintenance-mode Functions .....	7-3
1.4.1 EEPROM parameter initialization (Function code 01, 91) .....	7-3
1.4.2 Monochrome image quality test pattern (Function code 09).....	7-4
1.4.3 Worker switch (WSW) setting and printout (Function code 10, 11) .....	7-5
1.4.4 Operational check of LCD (Function code 12) .....	7-8
1.4.5 Operational check of control panel button (Function code 13) .....	7-9
1.4.6 Software version check (Function code 25).....	7-10
1.4.7 “One Push Demo” setting (Function code 28) .....	7-11
1.4.8 Operational check of sensors (Function code 32) .....	7-12
1.4.9 Not-disclosed-to-users functions (Function code 45) .....	7-15
1.4.10 Adjustment of color registration (Function code 66) .....	7-19
1.4.11 Continuous print test (Function code 67).....	7-22
1.4.12 LED test pattern print (Function code 68).....	7-24
1.4.13 Frame pattern print (Function code 69) .....	7-26
1.4.14 Color test pattern (Function code 71) .....	7-28
1.4.15 Sensitivity adjustment of density sensor (Function code 72).....	7-30
1.4.16 Setting by country (Function code 74).....	7-31
1.4.17 Sensitivity adjustment of registration mark sensor and check of belt surface (Function code 75).....	7-33
1.4.18 Operational check of fans (Function code 78).....	7-35
1.4.19 Display of the machine’s log (Function code 80).....	7-36
1.4.20 Error code indication (Function code 82).....	7-40
1.4.21 Developing bias voltage correction (Function code 83).....	7-41
1.4.22 Exit from the maintenance mode (Function code 99).....	7-42

<b>2. OTHER SERVICE FUNCTIONS.....</b>	<b>7-43</b>
2.1 Not-disclosed-to-users Function Menus Enabled by Pressing Button (s) When Turning the Machine On.....	7-43
2.2 Develop Roller Counter Reset Function .....	7-45
2.3 Parts Life Reset Function .....	7-46
2.4 Printout of Printer Settings.....	7-47
2.5 How to Recover from Errors of the Fuser Unit .....	7-51
2.6 Switching of Return Value of USB No./Support for Banding.....	7-52

# 1. MAINTENANCE MODE

---

The maintenance mode is exclusively designed for the checking, setting and adjustments of the machine by using the buttons on the control panel cover ASSY. You can perform operational checks of sensors, perform a print test, display the log information or error codes, and modify the worker switch (WSW).

## 1.1 How to Enter the Maintenance Mode

### <Operating procedure>

- (1) Press the **OK** button and then the **Go** button while the machine is in the ready state. Next, press the **▲** button four times to enter the maintenance mode.

#### Note:

To enter the maintenance mode, you must press the **Go** button within 2 seconds after pressing the **OK** button. Also, you need to press the **▲** button within 2 seconds after pressing the **Go** button.

- (2) The machine displays “■■ MAINTENANCE ■■■” on the LCD, indicating that it is placed in the initial state of the maintenance mode, a mode in which the machine is ready to accept entry from the buttons.
- (3) To select one of the maintenance-mode functions listed in the [next page](#), press the **▲** or **▼** button to display any function code on the LCD. Then press the **OK** button.

## 1.2 How to Enter the End User-accessible Maintenance Mode

Basically, the maintenance-mode functions listed in the [next page](#) should be accessed by service personnel only. However, you can allow end users to access some of these under the guidance of service personnel by phone, for example.

The end user-accessible functions are **shaded** in the table given on the [next page](#). (codes [09](#), [12](#), [25](#), [28](#), [68](#), [71](#), [72](#), [75](#), [80](#), [82](#) and [91](#))

### <Operating procedure>

- (1) Press the **OK**, **Go** and **OK** buttons in this order when the machine is in the ready state. “0” appears on the LCD.
- (2) Press the **▲** or **▼** button to display the desired maintenance code on the LCD. Then press the **OK** button.

When each of the user-accessible functions is completed, the machine automatically returns to the ready state. As for the codes [12](#), [25](#), [28](#), [45](#), [68](#), [71](#), [72](#), [75](#), [80](#) and [82](#), press the **Cancel** button to switch the machine return to the ready state.

## 1.3 List of Maintenance-mode Functions

Function code	Function	Refer to:
01	EEPROM parameter initialization	1.4.1 (7-3)
09	Monochrome image quality test pattern	1.4.2 (7-4)
10	Worker switch (WSW) setting	1.4.3 [1] (7-5)
11	Printout of worker switch (WSW) data	1.4.3 [2] (7-7)
12	Operational check of LCD	1.4.4 (7-8)
13	Operational check of control panel button	1.4.5 (7-9)
25	Software version check	1.4.6 (7-10)
28	“One Push Demo” setting	1.4.7 (7-11)
32	Operational check of sensors	1.4.8 (7-12)
45	Not-disclosed-to-users functions	1.4.9 (7-15)
66	Adjustment of color registration	1.4.10 (7-19)
67	Continuous print test	1.4.11 (7-22)
68	LED test pattern print	1.4.12 (7-24)
69	Frame pattern print	1.4.13 (7-26)
71	Color test pattern	1.4.14 (7-28)
72	Sensitivity adjustment of density sensor	1.4.15 (7-30)
74	Setting by country	1.4.16 (7-31)
75	Sensitivity adjustment of registration mark sensor and check of belt surface	1.4.17 (7-33)
78	Operational check of fans	1.4.18 (7-35)
80	Display of the machine’s log	1.4.19 (7-36)
82	Error code indication	1.4.20 (7-40)
83	Developing bias voltage correction	1.4.21 (7-41)
91	EEPROM parameter initialization	1.4.1 (7-3)
99	Exit from the maintenance mode	1.4.22 (7-42)

\*The functions shaded in the table above are user-accessible.



## 1.4 Detailed Description of Maintenance-mode Functions

### 1.4.1 EEPROM parameter initialization (Function code 01, 91)

#### <Function>

This function initializes the setting values of the operation parameters, user switches, and worker switches (WSW) registered in the EEPROM.

Entering function code 01 initializes almost all of the EEPROM areas, but entering 91 does not initialize some areas, as listed below.

Data item	Function code 01	Function code 91
User switches (Items to be initialized when resetting to the factory default settings)	All of these will be initialized.	These will be initialized.
Worker switch (Refer to <a href="#">APPENDIX 1.</a> )		These will <b>not</b> be initialized.
Function settings except user switches (Items except the factory default settings) - Languages - Reprint - Secure Print - Interfaces		These will be initialized.
LAN area (Network settings)		
PCL core area (Emulation settings) (HL-3070CW only)		
Operation lock of the control panel password		These will <b>not</b> be initialized.

#### <Operating procedure>

- (1) Press the ▲ or ▼ button to display “MAINTENANCE 01” (or “MAINTENANCE 91” according to your need) on the LCD in the initial state of the maintenance mode. Then, press the **OK** button. The “PARAMETER INIT” appears on the LCD.
- (2) Upon completion of parameter initialization, the machine returns to the initial state of the maintenance mode.

## 1.4.2 Monochrome image quality test pattern (Function code 09)

### <Function>

This function allows you to print various monochrome test patterns and check the quality and if there is any image loss.

### <Operating procedure>

- (1) Press the ▲ or ▼ button to display “MAINTENANCE 09” on the LCD in the initial state of the maintenance mode. Then, press the OK button.
- (2) Printing of a monochrome image quality test pattern (see the figure below) is started. When printing is finished, the machine returns to the initial state of the maintenance mode.

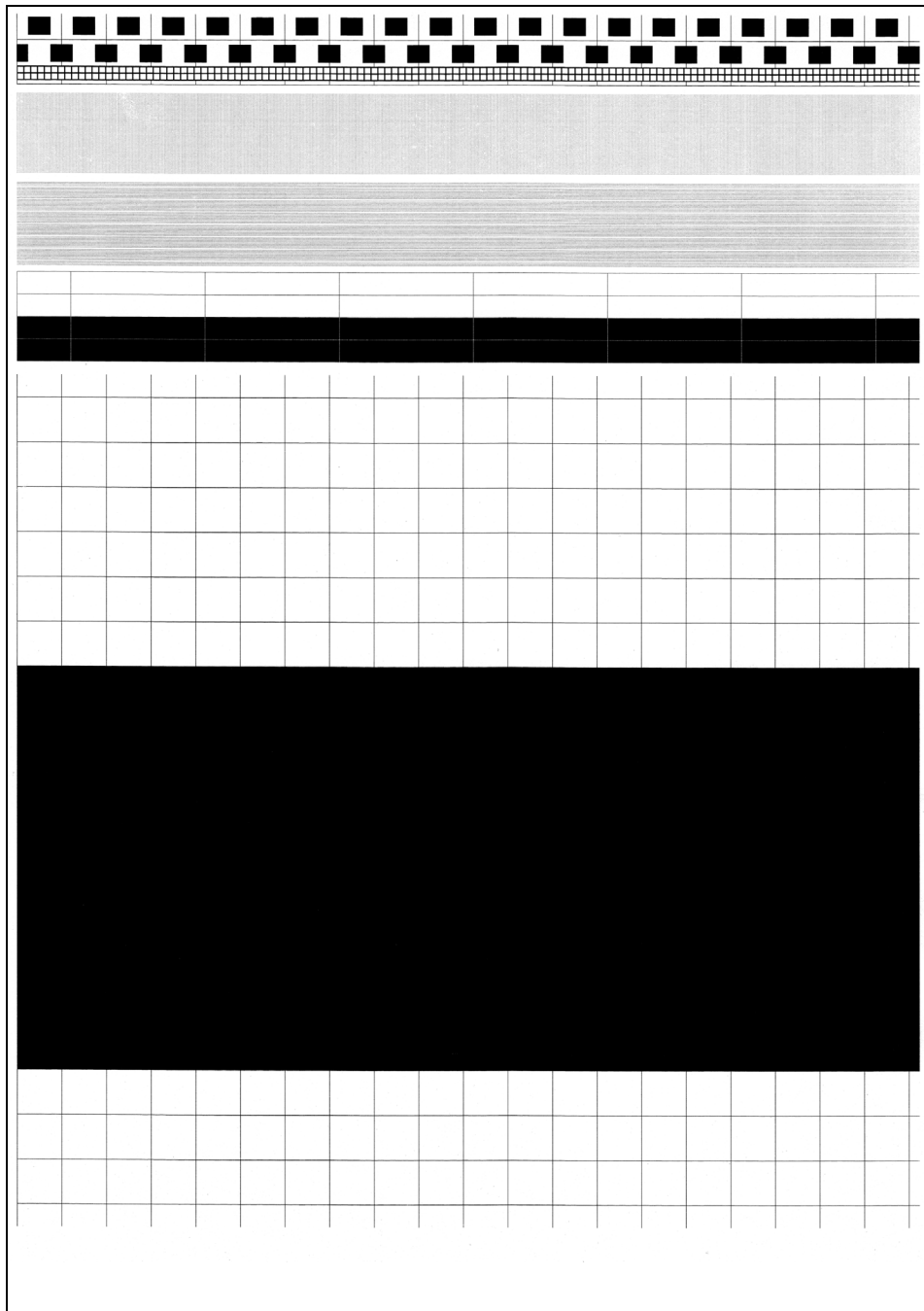

Fig. 7-1

### 1.4.3 Worker switch (WSW) setting and printout (Function code 10, 11)

#### [1] Worker switch setting (Function code 10)

##### <Function>

The machine incorporates the following worker switch functions which may be activated with the procedures using the buttons on the control panel cover ASSY. The worker switches have been set at the factory in conformity to the communications standards and codes of each country. Do not disturb them unless necessary. Some worker switches may not be applicable in some versions. The worker switch data list indicates "Not used." for those inapplicable switches.

**! CAUTION**  
**DO NOT** change any other worker switches except below.

WSW No.	Function	Refer to:
<b>WSW47</b>	Switching between high-speed USB and full-speed USB	App. 1-2
<b>WSW54</b>	PictBridge command delay time (HL-3070CW only)	App. 1-2
<b>WSW55</b>	Interval of time required for the developing bias voltage correction	App. 1-3
<b>WSW56</b>	"Last Job Reprint" function setting	App. 1-4
	Switching of the display for the coverage of toner cartridge	
	Switching of the CPU sleep mode	
<b>WSW59</b>	Enabling and disabling of transmission of USB serial number (SN)	App. 1-4
<b>WSW63</b>	Font support for Israel	App. 1-5
<b>WSW64</b>	Language setting	App. 1-5
	Default paper size	
<b>WSW65</b>	Default media type	App. 1-5
	Support for Bond paper	
	Support for Hagaki	
	Support for Label	
<b>WSW66</b>	Reserved (Change of the setting is prohibited)	App. 1-6
<b>WSW67</b>	Reserved (Change of the setting is prohibited)	App. 1-6
<b>WSW68</b>	Reserved (Change of the setting is prohibited)	App. 1-6
<b>WSW70</b>	Reserved (Change of the setting is prohibited)	App. 1-6
<b>WSW73</b>	Reserved (Change of the setting is prohibited)	App. 1-6

\* For details of the worker switches (WSW), refer to APPENDIX 1.

### <Operating procedure>

- (1) Press the ▲ or ▼ button to display “MAINTENANCE 10” on the LCD in the initial state of the maintenance mode. Then, press the **OK** button.
- (2) The machine displays “WSW00” on the LCD and becomes ready to accept a worker switch number.
- (3) Press the ▲ or ▼ button to select the desired number from the worker switch numbers. Then, press **OK** button.
- (4) The following appears on the LCD.

Selector 1      Selector 8  
↓                    ↓  
WSWXX = 0 0 0 0 0 0 0 0

- (5) “1” is set by pressing the ▲ button and “0” is set by pressing the ▼ button. Press the ▲ button if you want to input “1” to the selector 1 and press the ▼ button if you want to input “0.”
- (6) The cursor moves to the right onto the selector 2. Repeat to enter the desired number as described step (5) until the modification for the desired worker switches is completed till the selector 8. Press the **Back** button to go back to the previous selector if there is a mistake. Then, enter the desired number again.
- (7) Press the **OK** button when the setting value is entered. This operation saves the newly entered selector values onto the EEPROM and readies the machine for accepting a firmware switch number. The machine displays “WSW00” on the LCD again to accept a worker switch number.
- (8) Press the **Cancel** button to return to the machine to the initial state of the maintenance mode.

#### **Memo:**

- To cancel this operation and return to the machine to the initial state of the maintenance mode during the above procedure, press the **Cancel** button.
- If there is a pause of more than one minute, the machine will automatically return to the initial state of the maintenance mode.

## [2] Printout of worker switch data (Function code 11)

### <Function>

The machine prints out the setting items of the worker switches and their contents specified.

### <Operating procedure>

- (1) Press the ▲ or ▼ button to display “MAINTENANCE 11” on the LCD in the initial state of the maintenance mode. Then, press the OK button. The machine displays “PRINTING” on the LCD.
- (2) Printing of the CONFIGURATION LIST (see the figure below) is started. When printing is finished, the machine returns to the initial state of the maintenance mode.

```

                                CONFIGURATION LIST
                                MODEL : 84E-201
                                REV.  : U0809161919VER.V
                                FCI   : 5.00
                                SUM   : AAB8

WSW01 = 0000010
1-2. DIAL FORMAT                : NORMAL
3-4. BREAK TIME                 : 60 MS
5-6. INTERDIGIT PAUSE          : 800 MS
7. DP/PB CHANGE IN USER SW    : ND
8. DP/PB FIXING SELECTION      : PB
WSW02 = 11111010
1-2. ON TIME                   : 100 MS
3-4. OFF TIME                  : 140 MS
5-8. LINE BEEP ATTENUATOR      : 10 DB
WSW03 = 10110000
1. PARA. CNG DETECTION1       : B
2-4. NOT USED
5. PARA. CNG DETECTION2      : A
6-8. NOT USED
WSW04 = 00010110
1-4. NOT USED
5. DGM DELAY +4SEC           : OFF
6-8. FLASHING TIME           : 500 MS
WSW05 = 00000110
1-3. DIAL TONE DETECTION      : 3.5 SEC WAITING
4. REMOTE ID DETECTION TIMEOUT : 2 SEC
5-6. BUSY TONE DETECTION (CALLING) : AFTER DIALING
7. BUSY TONE DETECTION (CALLED) : OFF
8. NOT USED
WSW06 = 00101100
1-3. PAUSE KEY                : 3.5 SEC WAITING
4-6. 2ND DT DETECTION TIME    : 800 MS
7. 2ND DT DETECTION CYCLE     : 1 CYCLE
8. 2ND DT INTERRUPT DETECTION TIME : 30 MS
WSW07 = 01001100
1-2. FREQUENCY RANGE         : INITIAL DATA
3. NOT USED
4-6. 2ND DT DETECTION LEVEL   : -30 DBM
7. 1ST DT INTERRUPT DETECTION TIME : 30 MS
8. NOT USED
WSW08 = 01100111
1-3. 1ST DT DETECTION TIME    : 800 MS
4-5. 1ST/2ND DT TIME OUT     : 10 SEC
6-8. 1ST DT DETECTION LEVEL   : -42 DBM
WSW09 = 00000000
1. ECM FRAME                  : 256 OCTET
2. NON STANDARD FACILITIES   : ON
3-4. TIMES OF FALL BACK      : 4
5. T5 TIMER                   : 300 SEC
6. T1 TIMER                   : 35 SEC
7-8. CALLING TIMEOUT         : 55 SEC
WSW10 = 00010100
1. NOT USED
2. TIMING OF LAST DIGIT-MODEM CHANGE : 100 MS
3. TIMING OF CML ON CNG TRANSMISSION : 2 SEC
4. TIMING OF CML ON CED TRANSMISSION : 2 SEC
5-6. TRAINING RETRIES        : 2
7. CODING METHOD MR          : ON
8. CODING METHOD MMR         : ON
WSW11 = 01011000
1-2. FREQUENCY RANGE         : INITIAL DATA
3-8. ON/OFF TIME             : 175 - 600 / 175 - 600 MS
WSW12 = 10011011
1-2. OFF DETECTION TIME      : 700 MS
3-4. AUTO ANS OFF DETECTION TIME : 7 SEC
5-6. ON DETECTION TIME       : 250 MS
7-8. NOT USED
```

Fig. 7-2

#### Note:

The function names specific to multi-function machines are printed in CONFIGURATION LIST for convenience of program development. They are invalid in this product and should be ignored.

These settings must not be changed.

## 1.4.4 Operational check of LCD (Function code 12)

### <Function>

This function allows you to check whether the LCD on the control panel cover ASSY works normally.

### <Operating procedure>

- (1) Press the ▲ or ▼ button to display “MAINTENANCE 12” on the LCD in the initial state of the maintenance mode. Then, press the OK button.
- (2) Each time you press the Go button, the LCD cycles through the displays as shown below.
- (3) Press **Cancel** button in any process of the display cycle. The machine returns to the initial state of the maintenance mode.

<Display 1>	
Backlight	: OFF
LCD	: Display of all dots
Data LED	: Green blinking
Error LED	: Red blinking
<Display 2>	
Backlight	: OFF
LCD	: Display of 16 frames per line
Data LED	: Green blinking
Error LED	: Red blinking
<Display 3>	
Backlight	: OFF
LCD	: Display of no dots
Data LED	: Green blinking
Error LED	: Red blinking
<Display 4>	
Backlight	: ON (HL-3070CW only)
LCD	: Display of no dots
Data LED	: Green blinking
Error LED	: Red blinking

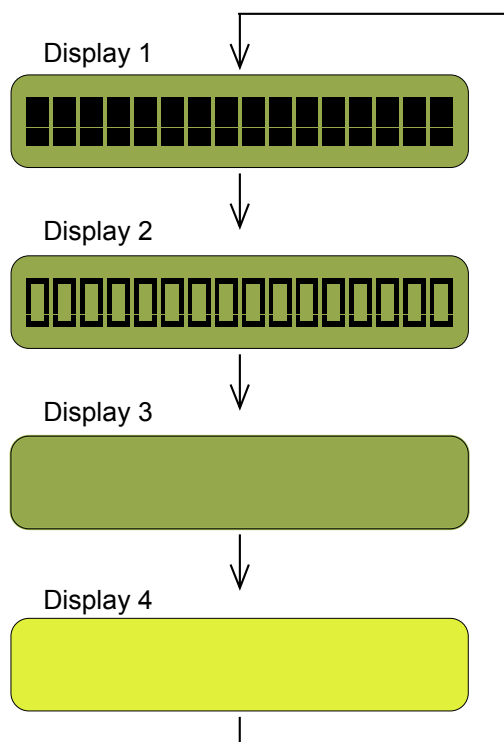

Fig. 7-3

## 1.4.5 Operational check of control panel button (Function code 13)

### <Function>

This function allows you to check if the buttons on the control panel cover ASSY work properly.

### <Operating procedure>

- (1) Press the ▲ or ▼ button to display “MAINTENANCE 13” on the LCD in the initial state of the maintenance mode. Then, press the **OK** button. The machine displays “00” on the LCD.
- (2) Press the buttons in the order designated in the illustration shown below.  
The LCD shows the corresponding number in decimal notation each time a button is pressed. Check that the displayed number is correct by referring to the illustration below. If a button is pressed out of order, the machine displays the “INVALID OPERATE” on the LCD. To return to the ready state to accept button entry for operational check, press the **Cancel** button.
- (3) After the last number button is pressed, the machine returns to the initial state of the maintenance mode.

#### **Memo:**

To terminate this operation, press the **Cancel** button. The machine returns to the initial state of the maintenance mode.

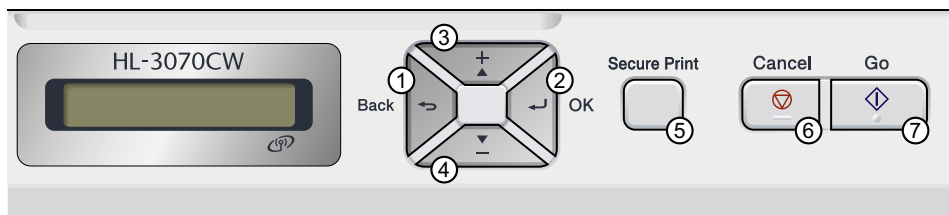

Fig. 7-4

## 1.4.6 Software version check (Function code 25)

### <Function>

This function allows you to check the management information of the software programs such as version information, check sum.

### <Operating procedure>

- (1) Press the ▲ or ▼ button to display “MAINTENANCE 25” on the LCD in the initial state of the maintenance mode. Then, press the **OK** button. The machine displays each of items described below on the LCD.
- (2) Press the **Go**, ▲ or ▼ button to check the next item.
- (3) To terminate this operation, press the **Cancel** button. The machine returns to the initial state of the maintenance mode.

LCD	Description
MAIN: Ver1.00 (A)* <sup>1</sup>	Main firmware version information (A): Revision information
PCL : Ver1.00 (P)* <sup>1</sup>	Sub firmware (GDI or PCL/PS) version information (P): Identifier of GDI or PCL/PS* <sup>2</sup>
ENG : Ver1.00	Engine firmware version information
NET : Ver1.00	Network program version information
PICT: Ver1.00	PictBridge version information (HL-3070CW only)
HV : Ver1.00 BXXX	High voltage CPU program version and PCB information
B0608071049:5708* <sup>1</sup>	Boot program creation date
U0612271600:7B0A* <sup>1</sup>	Main firmware creation date
D0611301115:E6C3* <sup>1</sup>	Demo firmware data creation date
P0612271602:BD40* <sup>1</sup>	Sub firmware (GDI or PCL/PS) creation date
ROM Check Sum	Check sum self-diagnosis function* <sup>3</sup>

\*<sup>1</sup> How to display the check sum information

Press the **OK** button when its version information is displayed on the LCD to display the check sum information. Press the **OK** button again to go back to the version information display. Press the **Go**, ▲ or ▼ button to check the next item.

#### **Note:**

Regarding the version information (Engine, Network, PictBridge, and HVPS) of which check sum information cannot be obtained, the check sum information is not displayed even if you press the **OK** button.

\*<sup>2</sup> (P) indicates that the firmware supports PCL/PS, and (G) indicates that it supports GDI.

\*<sup>3</sup> There are two types of check sum information which can be checked with this function. This function checks if these two types of check sum information are matched each other. When you press the **OK** button while “ROM Check Sum” is displayed, check is automatically conducted for each ROM of each software part. When the check sum is matched, “OK” is displayed on the LCD. When all ROMs result in OK, “ROM Check Sum OK” is displayed at the end, and the operation is finished. When the check sum of any ROM is not matched, NG is displayed, and the display stops.



## 1.4.7 “One Push Demo” setting (Function code 28)

### <Function>

The One Push Demo function is to implement demo printing by pressing the **Go** button, which is mainly used for sales promotion at the shop. It is disabled if printing from a computer even once.

Therefore, it is necessary to change the setting so that the function is enabled again.

OnePushDemo = ON (Enabled) / OFF (Disabled)

The default setting is displayed with “\*”.

### <Operating Procedure: How to set “OnePushDemo = ON”>

- (1) Press the ▲ or ▼ button to display “MAINTENANCE 28” on the LCD in the initial state of the maintenance mode. Then, press the **OK** button. The machine displays “One Push Demo=ON” on the LCD.
- (2) Press the **OK** button so that the One Push Demo function is set to be enabled.
- (3) The machine automatically returns to the initial state of the maintenance mode.

#### **Note:**

- To terminate this operation, press the **Cancel** button. The machine returns to the initial state of the maintenance mode.
- Once the One Push Demo function is enabled, printing from a computer does not disable this function unless the power is turned OFF. (After the One Push Demo function is enabled, if the power is turned OFF and ON again, and then printing is made from a computer, the function is disabled.)

## 1.4.8 Operational check of sensors (Function code 32)

### <Function>

This function allows you to check each of the sensors.

### <Operational procedure>

- (1) Press the ▲ or ▼ button to display “MAINTENANCE 32” on the LCD in the initial state of the maintenance mode. Then, press the **OK** button.
- (2) The operation condition of the sensor becomes the one defined in the table below, and “P1MPCVRCRMRAPOFW” is displayed on the LCD. When the **Go** button is pressed, the selected item is switched to the next item.

Given below is the relationship between the LCD indication, sensor name and sensor state.

LCD	Sensors	Sensing status (OK/NG)
P1	Paper eject rear sensor	Paper not detected/detected
MP	Manual sensor	Paper not detected/detected
CV	Top cover sensor	Top cover closed/open
RC	Back cover sensor	Back cover closed/open
RM	Registration front sensor	Paper not detected/detected
RA	Registration rear sensor	Paper not detected/detected
PO	Paper eject front sensor	Paper not detected/detected
FW	Waste toner sensor	Toner full/not detected
NK	New toner sensor K	OFF/ON
NY	New toner sensor Y	OFF/ON
NM	New toner sensor M	OFF/ON
NC	New toner sensor C	OFF/ON
KC	Toner sensor K	Toner (K) detected/not detected
YC	Toner sensor Y	Toner (Y) detected/not detected
MC	Toner sensor M	Toner (M) detected/not detected
CC	Toner sensor C	Toner (C) detected/not detected

#### Note:

- The “--” appears on the LCD if there is no display.
- The “\*\*\*” appears on the LCD if the parts are not installed or there is no item.

LCD	Sensors	Sensing status (OK/NG of temperature/humidity)
TMP	External temperature sensor	XX C/NG
HUM	External humidity sensor	XX%/NG
MAC	Internal temperature sensor	XX C/NG
BT	Belt thermistor	XX C/NG

**Note:**

If the sensor detects the abnormal value, the machine displays “NG” on the LCD.

- (3) Change the detecting conditions to check that the indication on the LCD changes according to the sensor state. For instance, insert paper through the registration front/rear sensor, open the top cover or the back cover, remove the toner cartridge, jam paper at the paper outlet and insert paper from the manual feed slot, etc.
- (4) Press the **Cancel** button to return the machine to the initial state of the maintenance mode.

■ Location of sensors

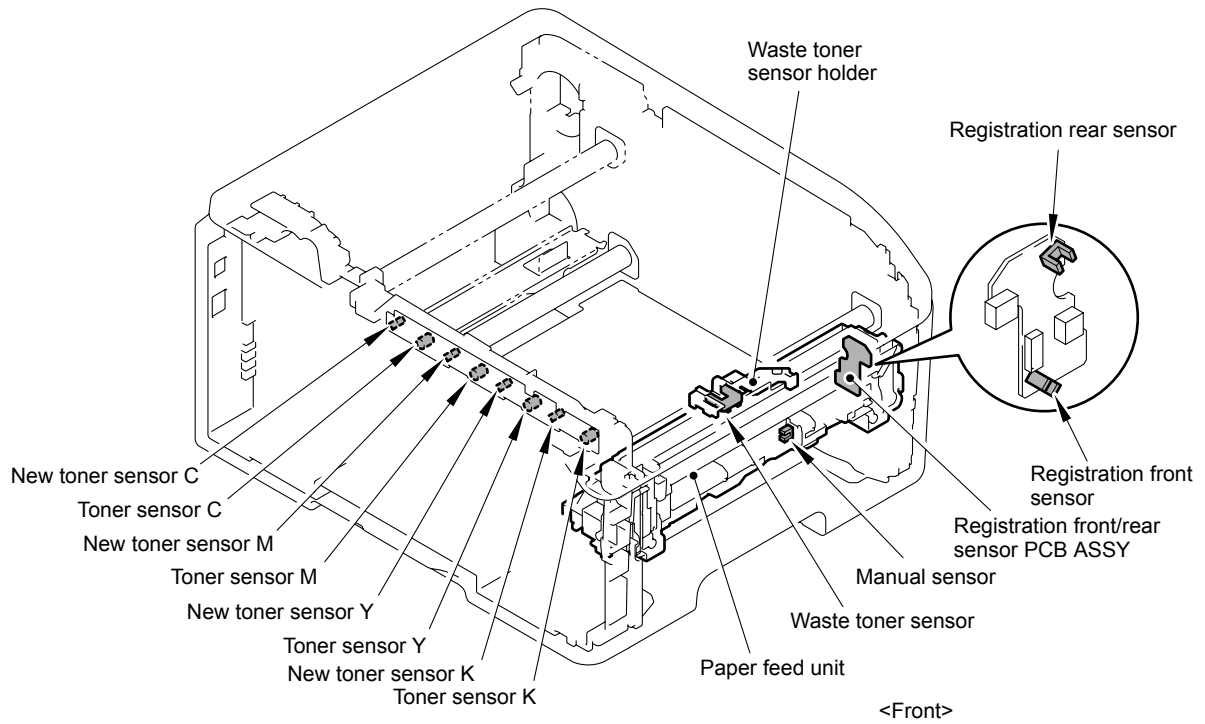

Fig. 7-5

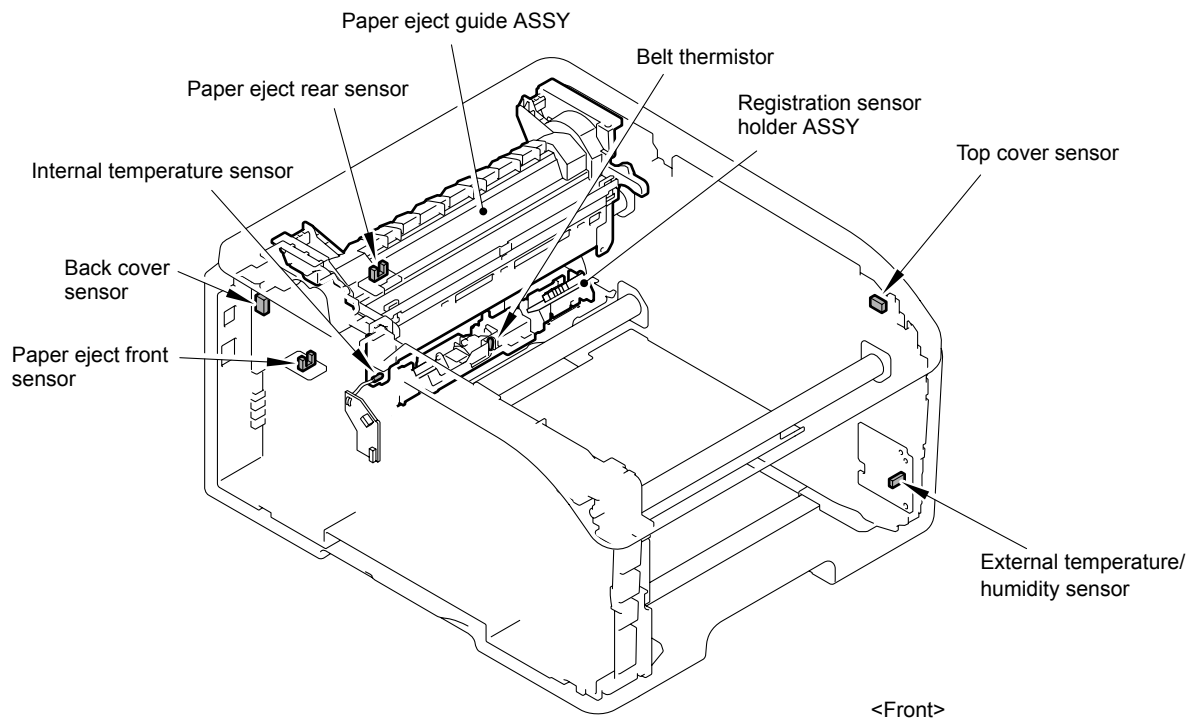

Fig. 7-6

### 1.4.9 Not-disclosed-to-users functions (Function code 45)

Regarding the not-disclosed-to-users functions, the function setting can be executed by a simple panel operation. (Refer to “2.6 Switching of Return Value of USB No./Support for Banding” in this chapter.)

#### ■ Switching of the USB transfer speed in the PictBridge mode

##### <Function>

This function allows you to change the USB transfer speed in the PictBridge mode. If the digital camera which a user uses cannot be connected in the PictBridge mode, this function may make it possible.

LCD	Description
PB.Speed=AUTO	Adapts the speed to the capability of the USB device. (Full Speed or High Speed) (default)
PB.Speed=FULL	Fixes the speed to Full Speed. The capability of the USB device is not depended on.

An asterisk “\*” appears beside the current setting.

##### <Operating procedure>

- (1) Press the ▲ or ▼ button to display “MAINTENANCE 45” on the LCD in the initial state of the maintenance mode. Then, press the **OK** button. “PB.USBspeed” will appear on the LCD.
- (2) Press the **OK** button. Then, select the required function by pressing the ▲ or ▼ button and press the **OK** or **Go** button.
- (3) The machine returns to the initial state of the maintenance mode.
- (4) Turn the power switch of the machine OFF.

##### **Note:**

This mode is enabled when the power of the machine is turned OFF and ON.

## ■ Changing return value of USB No.

### <Function>

When the OS of the computer is Windows Vista<sup>®</sup>, and the computer is connected to a device through USB 2.0 full speed, the OS might fail to get the serial No. of the USB device depending on the computer and USB device. When the OS fails to get the serial No., the return value may continue to increase every time the device is connected to the computer. To avoid this problem, the return value of the serial No. is dropped to "0".

LCD	Description
USBNo. =ON	Returns the serial No. of the device. (default)
USBNo. =OFF	Returns "0".

An asterisk "\*" appears beside the current setting.

### <Operating procedure>

- (1) Press the ▲ or ▼ button to display "MAINTENANCE 45" on the LCD in the initial state of the maintenance mode. Then, press the **OK** button. "PB.USBspeed" will appear on the LCD.
- (2) Press the ▲ or ▼ button to display "USB No." and then press the **OK** or **Go** button.
- (3) Press the ▲ or ▼ button to select "USB No. = ON" or "USB No. = OFF," and then press the **OK** or **Go** button.
- (4) The machine returns to the initial state of the maintenance mode.
- (5) Turn the power switch of the machine OFF.

#### **Note:**

This mode is enabled when the power of the machine is turned OFF and ON.

## ■ Switching dither pattern

### <Function>

This function is to switch the dither pattern when printed letters and/or slanted lines are not smooth, and thin lines are rough or uneven.

LCD	Description
PS.DitherType=0	Dither Pattern 0 is selected. (A dither pattern which improves roughness of letters and slanted lines)
PS.DitherType=1	Dither Pattern 1 is selected. (A dither pattern which alleviates banding) (default)

An asterisk "\*" appears beside the current setting.

### <Operating procedure>

- (1) Press the ▲ or ▼ button to display "MAINTENANCE 45" on the LCD in the initial state of the maintenance mode. Then, press the **OK** button. "PB.USBspeed" will appear on the LCD.
- (2) Press the ▲ or ▼ button to display "PS.DitherType" and then press the **OK** or **Go** button.
- (3) Press the ▲ or ▼ button to select "PS.DitherType=0" or "PS.DitherType=1," and then press the **OK** or **Go** button.
- (4) The machine returns to the initial state of the maintenance mode.

## ■ Switching ON/OFF of 94 mm banding measure GridBias control function

### <Function>

This function is to switch ON/OFF of the control (Engine control) to make print by increasing GridBias at the 94-mm position from the leading edge of each page in order to avoid a banding failure.

LCD	Description
Bd94GrdBias=ON	94 mm Banding measure GridBias control function ON (default)
Bd94GrdBias=OFF	94 mm Banding measure GridBias control function OFF

An asterisk "\*" appears beside the current setting.

### <Operating procedure>

- (1) Press the ▲ or ▼ button to display "MAINTENANCE 45" on the LCD in the initial state of the maintenance mode. Then, press the **OK** button. "PB.USBspeed" will appear on the LCD.
- (2) Press the ▲ or ▼ button to display "Bd94GrdBias" and then press the **OK** or **Go** button.
- (3) Press the ▲ or ▼ button to select "Bd94GrdBias=ON" or "Bd94GrdBias=OFF," and then press the **OK** or **Go** button.
- (4) The machine returns to the initial state of the maintenance mode.

## ■ Switching ON/OFF of 94 mm Banding measure transfer current correction/ DCLN voltage correction

### <Function>

This function is to switch ON/OFF of the transfer current correction/DCLN voltage correction control (Engine control) to the 94-mm position from the leading edge of each page in order to avoid a banding failure. When banding appears, switch this control as a measure.

LCD	Description
Bd94CrctSub=ON	94 mm Banding measure transfer current correction/ DCLN voltage correction ON
Bd94CrctSub=OFF	94 mm Banding measure transfer current correction/ DCLN voltage correction OFF (default)

An asterisk “\*” appears beside the current setting.

### <Operating procedure>

- Press the ▲ or ▼ button to display “MAINTENANCE 45” on the LCD in the initial state of the maintenance mode. Then, press the **OK** button. “PB.USBspeed” will appear on the LCD.
- Press the ▲ or ▼ button to display “Bd94CrctSub” and then press the **OK** or **Go** button.
- Press the ▲ or ▼ button to select “Bd94CrctSub=ON” or “Bd94CrctSub=OFF,” and then press the **OK** or **Go** button.
- The machine returns to the initial state of the maintenance mode.

## ■ Switching ON/OFF of DirectPrint Color mode - Improve Gray Color

### <Function>

This function is to switch ON/OFF of the print control for the gray color when other colors are slightly blended in the gray color or the gray color is uneven upon printing.

LCD	Description
DP.ImpGray=ON	DirectPrint Color mode - Improve Gray Color. (Print control for gray color) ON (Improves the symptom that other colors are slightly blended in the gray color.) (default)
DP.ImpGray=OFF	DirectPrint Color mode - Improve Gray Color. (Print control for gray color) OFF (Improves the unevenness of the gray color)

An asterisk “\*” appears beside the current setting.

### <Operating procedure>

- Press the ▲ or ▼ button to display “MAINTENANCE 45” on the LCD in the initial state of the maintenance mode. Then, press the **OK** button. “PB.USBspeed” will appear on the LCD.
- Press the ▲ or ▼ button to display “DP.ImpGray” and then press the **OK** or **Go** button.
- Press the ▲ or ▼ button to select “DP.ImpGray=ON” or “DP.ImpGray=OFF,” and then press the **OK** or **Go** button.
- The machine returns to the initial state of the maintenance mode.



## 1.4.10 Adjustment of color registration (Function code 66)

### <Function>

This function allows a service man to forcibly activate the color registration adjustment function, which is usually executed automatically in a specified condition. If adjustment of color registration fails because toner reaches its life, etc., you can adjust color registration manually.

### ■ Adjustment of color registration (auto)

#### <Operating procedure>

- (1) Press the ▲ or ▼ button to display “MAINTENANCE 66” on the LCD in the initial state of the maintenance mode. Then, press the **OK** button. “REGISTRATION” is displayed on the LCD.
- (2) Press the **OK** button. “PLEASE WAIT” is displayed on the LCD, and adjustment of color registration is automatically done.
- (3) When this operation is completed without an error, “COMPLETED” is displayed on the LCD.
- (4) Press the **Cancel** button to return to the machine to the initial state of the maintenance mode.

When an error message is displayed on the LCD, take the measures described in the table below.

Error message	Measure
FAILED	Press the <b>Go</b> button to clear the error. Adjust color registration manually in accordance with the procedure for adjustment of color registration (manual) given in the <a href="#">next page</a> .
TONER EMPTY # *	Replace the empty toner cartridge and press the <b>Go</b> button to clear the error. Conduct adjustment of color registration (auto) again.
No Paper	Replenish paper of the A4-size paper specified in the display on the tray.
REGI WIDTH ERROR	Press the <b>Go</b> button to clear the error.
Jam Tray 1	Remove the jammed paper, and press the <b>Go</b> button to clear the error.
Jam Rear	

\* # indicates the toner color (C, M, or Y) of which cartridge became empty.

#### Memo:

Although adjustment of color registration (auto) is executed several times and the result of color registration adjustment chart (P7-21) does not fall within the range of  $\pm 4$ , readjust it according to the following procedures.

#### <Operating procedure>

- 1) Press the ▲ or ▼ button to display “MAINTENANCE 66” on the LCD in the initial state of the maintenance mode. Then, press the **OK** button. “REGISTRATION” is displayed on the LCD. Load A4-size paper on the tray.
- 2) Press the ▲ or ▼ button to display “PRINT CHART” on the LCD, and then press the **OK** button.
- 3) Display “PRINTING” on the LCD, and print the color registration adjustment chart. After printing, “PRINT CHART” is displayed again.
- 4) Press the ▲ or ▼ button to display “OFFSET ADJUST” on the LCD, and then press the **OK** button. “4. MAGENTA = 0” is displayed on the LCD.

- 5) With the printed color registration adjustment chart, check the numeric value where the color is the darkest among the pattern ④ (Magenta Center). Press the ▲ or ▼ button to display that numeric value, and then press the **Go** button.
- 6) Enter the numeric value of the patterns ⑤ to ⑥ in the same way.
- 7) When you enter the numeric value of the pattern ⑥ (Yellow Center), "COMPLETED" is displayed.
- 8) Press the **Cancel** button to return to the machine to the initial state of the maintenance mode.

## ■ Adjustment of color registration (manual)

### <Operating procedure>

- (1) Press the ▲ or ▼ button to display "MAINTENANCE 66" on the LCD in the initial state of the maintenance mode. Then, press the **OK** button. "REGISTRATION" is displayed on the LCD. Load A4-size paper on the tray.
- (2) Press the ▲ or ▼ button to display "PRINT CHART" on the LCD, and then press the **OK** button.
- (3) Display "PRINTING" on the LCD, and print the color registration adjustment chart. After printing, "PRINT CHART" is displayed again.
- (4) Press the ▲ or ▼ button to display "SET REGISTRATION" on the LCD, and then press the **OK** button. "1. MAGENTA = 0" is displayed on the LCD.
- (5) With the printed color registration adjustment chart, check the numeric value where the color is the darkest among the pattern ① (Magenta Left). Press the ▲ or ▼ button to display that numeric value, and then press the **Go** button.
- (6) Enter the numeric value of the patterns ② to ⑨ in the same way.
- (7) When you enter the numeric value of the pattern ⑨ (Yellow Right), "COMPLETED" is displayed.
- (8) Press the **Cancel** button to return to the machine to the initial state of the maintenance mode.

■ Color registration adjustment chart

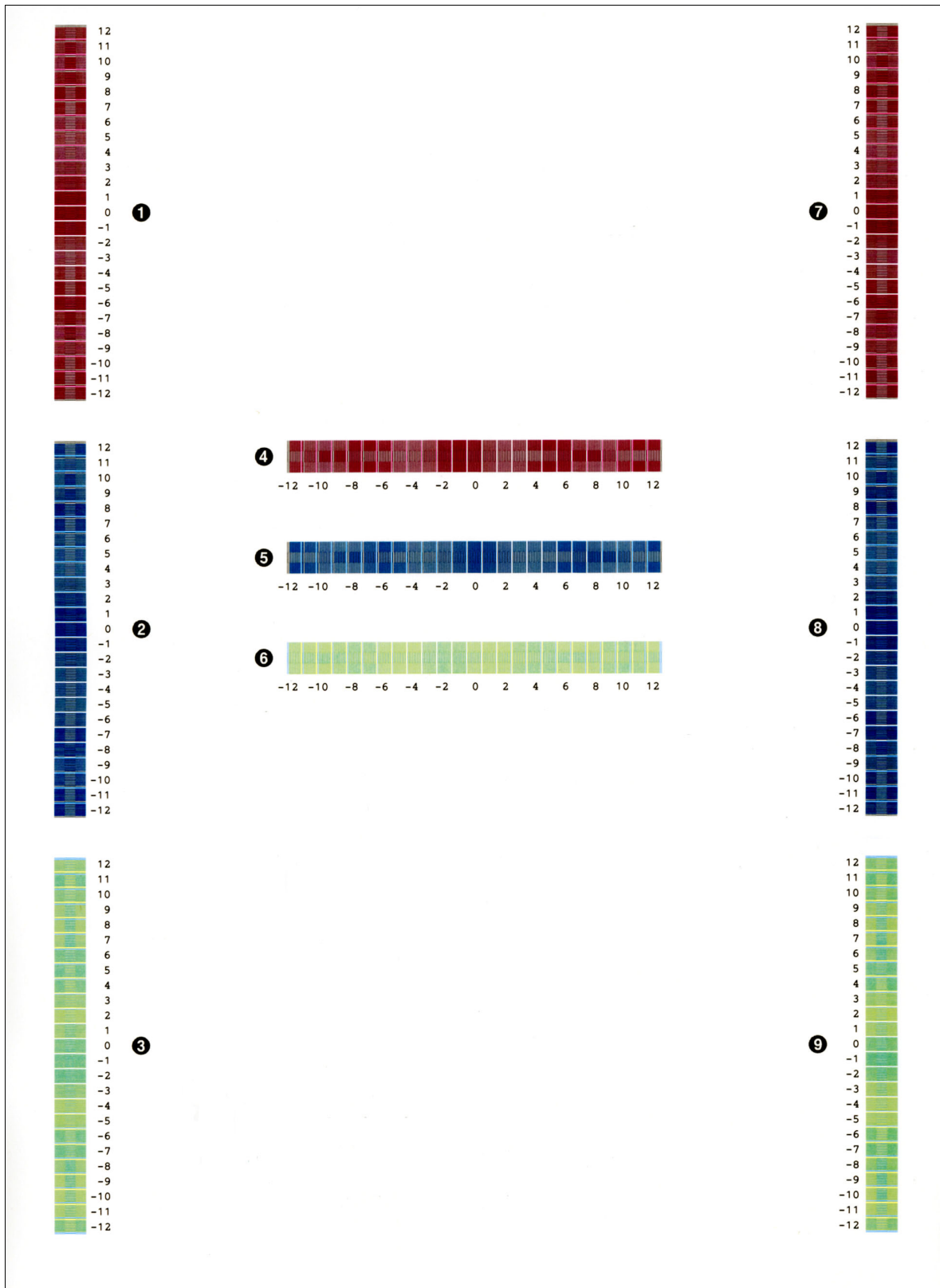

Fig. 7-7

## 1.4.11 Continuous print test (Function code 67)

### <Function>

This function allows you to conduct the pick-up and delivery test as printing patterns.

### <Operating procedure>

- (1) Press the ▲ or ▼ button to display “MAINTENANCE 67” on the LCD in the initial state of the maintenance mode. Then, press the **OK** button.
- (2) When “SELECT: K 100%” appears on the LCD, select a relevant continuous print pattern using ▲ or ▼ button, and then press the **OK** button.

The available continuous print patterns are shown below.

LCD
SELECT: K 100%
SELECT: C 100%
SELECT: M 100%
SELECT: Y 100%
SELECT: R 100%
SELECT: G 100%
SELECT: B 100%
SELECT: KCMY1%*
SELECT: KCMY5%*
SELECT: Lattice

\* KCMY1% and KCMY5% are available only for A4 and Letter.

- (3) When “SELECT: A4” appears on the LCD, select a relevant paper size using ▲ or ▼ button, and then press the **OK** button.

The available paper sizes are shown below.

LCD
SELECT: A4
SELECT: LETTER
SELECT: LEGAL
SELECT: A5
SELECT: B6
SELECT: A6

- (4) The “PAPER FEED TEST” appears on the LCD, and print of the continuous print pattern with the selected pick-up test items starts.
- (5) Press the **Cancel** button to return to the machine to the initial state of the maintenance mode.

#### Note:

- The machine continues the test printing until there is no paper in a tray. Press the **Cancel** button to stop if you check the paper feeding and ejecting operations. (Printing is resumed when paper is loaded in the tray.)
- In the case that the error occurs during test printing, the test printing is stopped. (Printing is resumed when the error is cleared.)
- To clear the error, remove the error factors, and then press the **Go** button.

■ Continuous print pattern

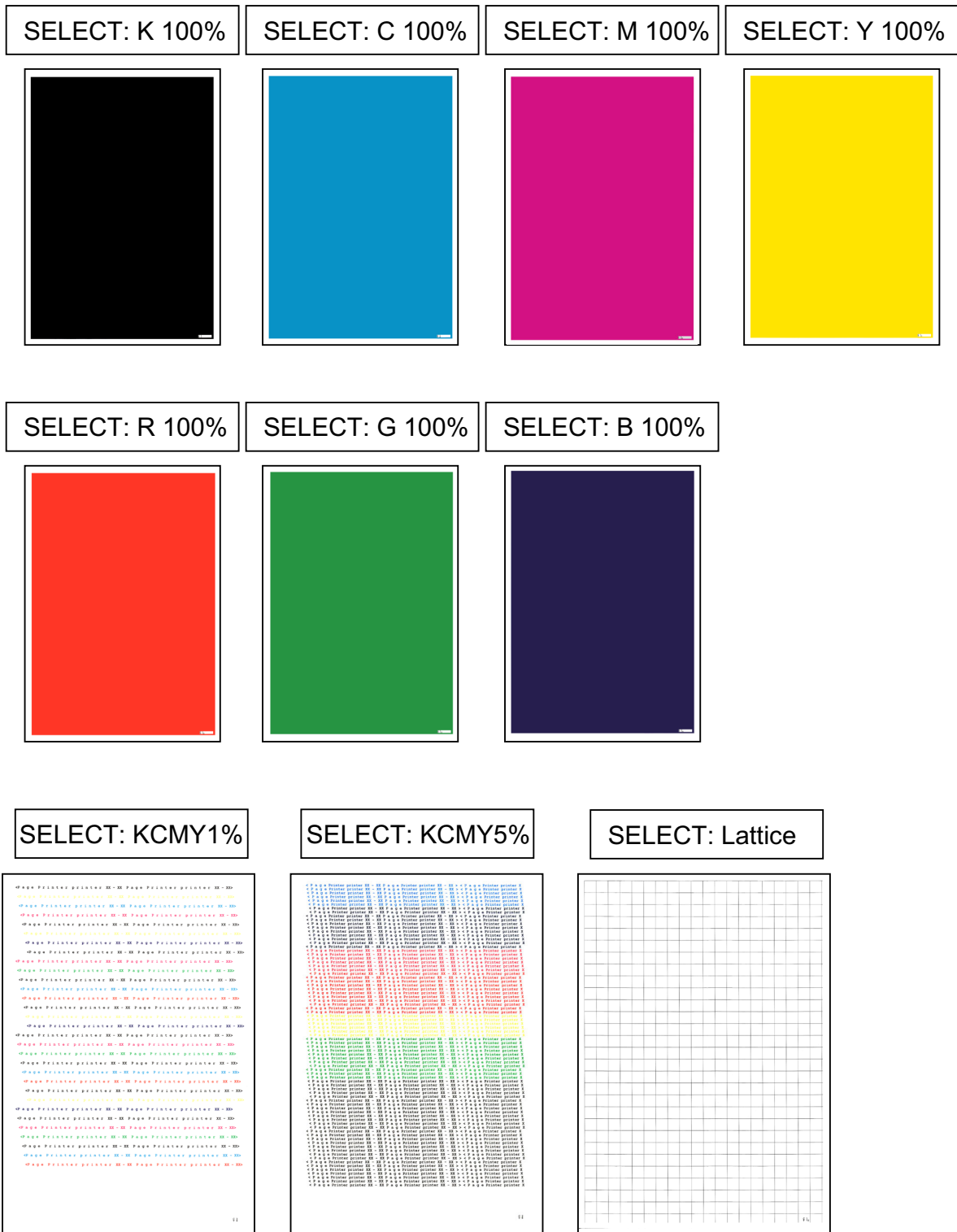

Fig. 7-8

## 1.4.12 LED test pattern print (Function code 68)

### <Function>

This function allows you to print the LED ASSY test pattern and check the quality of the LED ASSY and if it is lifted from the drum.

#### Note:

You can check scratches and smears on the LED by performing the continuous print test. (Refer to "1.4.11 Continuous print test (Function code 67)" in this chapter.)

### <Operating procedure>

- (1) Press the ▲ or ▼ button to display "MAINTENANCE 68" on the LCD in the initial state of the maintenance mode. Then, press the **OK** button.
- (2) When "M68\_L" is displayed on the LCD, press the **OK** button.

The available test patterns are shown below.

LCD	Description
M68_L	Vertical/horizontal dot loss check pattern

"PRINTING" is displayed on the LCD, and the LED test pattern is printed on a sheet.

#### Note:

When printing fails, a relevant error is displayed on the LCD. When the error factors are removed and the **Go** button is pressed, the machine automatically recovers to the re-executable state. "PRINTING" is displayed on the LCD, and the test pattern is printed on a sheet.

- (3) Press the **Cancel** button to return to the machine to the initial state of the maintenance mode.

When an error message is displayed on the LCD, take the measures described in the table below.

Error message	Measure
TONER EMPTY # *	Replace the empty toner cartridge and press the <b>Go</b> button to clear the error. Perform the LED test pattern print again.
Cover is Open	Close the top cover.
No Paper	Replenish paper, and press the <b>Go</b> button to clear the error.
Jam Tray1	Remove the jammed paper, and press the <b>Go</b> button to clear the error.
Jam Rear	Remove the jammed paper, and press the <b>Go</b> button to clear the error.

\* # indicates the toner color (K, Y, M, or C) of which cartridge became empty.

■ LED test pattern (M68\_L)

[M68\_L103]



Fig. 7-9

### 1.4.13 Frame pattern print (Function code 69)

#### <Function>

This function allows you to print the external periphery frame pattern on a sheet and check if there is print deflection and/or loss.

#### <Operating procedure>

- (1) Load Letter-size paper on the paper tray.
- (2) Press the ▲ or ▼ button to display "MAINTENANCE 69" on the LCD in the initial state of the maintenance mode. Then, press the **OK** button. "PRINTING" is displayed on the LCD, and the frame pattern (see the figure below) is printed on a sheet.

When printing fails, a relevant error is displayed on the LCD. When the error factors are removed and the **Go** button is pressed, the machine automatically recovers to the re-executable state. When the **OK** button is pressed, "PRINTING" is displayed on the LCD, and the frame pattern is printed on a sheet.

- (3) Press the **Cancel** button to return to the machine to the initial state of the maintenance mode.

When an error message is displayed on the LCD, take the measures described in the table below.

Error message	Measure
TONER EMPTY # *	Replace the empty toner cartridge and press the <b>Go</b> button to clear the error. Perform the frame pattern print again.
Cover is Open	Close the top cover.
No Paper	Replenish paper, and press the <b>Go</b> button to clear the error.
Jam Tray1	Remove the jammed paper, and press the <b>Go</b> button to clear the error.
Jam Rear	Remove the jammed paper, and press the <b>Go</b> button to clear the error.

\* # indicates the toner color (K, Y, M, or C) of which cartridge became empty.



	4.23mm	4.23mm
6.35mm (Letter size)		
6.35mm (Letter size)		

**Fig. 7-10**

## 1.4.14 Color test pattern (Function code 71)

### <Function>

This function allows you to print the pattern of each color and check if there is any smear on or failure in the belt unit, develop roller, and exposure drum, etc.

### <Operating procedure>

- (1) Press the ▲ or ▼ button to display “MAINTENANCE 71” on the LCD in the initial state of the maintenance mode. Then, press the **OK** button.
- (2) When “2D3S YCMK\_\_A” is displayed on the LCD, press the ▲ or ▼ button to select an appropriate print pattern, and press the **OK** button.
- (3) “PRINTING” is displayed on the LCD, and the color test pattern is printed.

The available print patterns are shown below.

LCD	Description
2D3S YCMK__A	One sheet for each color with full page print mode* Total 4 sheets
2D3S MCMYK	4-color horizontal band Total 1 sheet
2D3S Y	Yellow Total 1 sheet
2D3S C	Cyan Total 1 sheet
2D3S M	Magenta Total 1 sheet
2D3S K	Black Total 1 sheet

\* In the full page print mode, the cleaning operation is performed between printing of M and K.

When printing fails, a relevant error is displayed on the LCD. When the error factors are removed and the **Go** button is pressed, the machine automatically recovers to the re-executable state. “PRINTING” is displayed on the LCD, and the color test pattern is printed.

- (4) When printing is finished, the screen returns to the print pattern display. To print the solid color test pattern again, press the **OK** button.
- (5) Press the **Cancel** button to return to the machine to the initial state of the maintenance mode.

When an error message is displayed on the LCD, take the measures described in the table below.

Error message	Measure
TONER EMPTY # *	Replace the empty toner cartridge and press the <b>Go</b> button to clear the error. Perform the color test pattern print again.
Cover is Open	Close the top cover.
No Paper	Replenish paper, and press the <b>Go</b> button to clear the error.
Jam Tray1	Remove the jammed paper, and press the <b>Go</b> button to clear the error.
Jam Rear	Remove the jammed paper, and press the <b>Go</b> button to clear the error.

\* # indicates the toner color (K, Y, M, or C) of which cartridge became empty.

■ Color test pattern

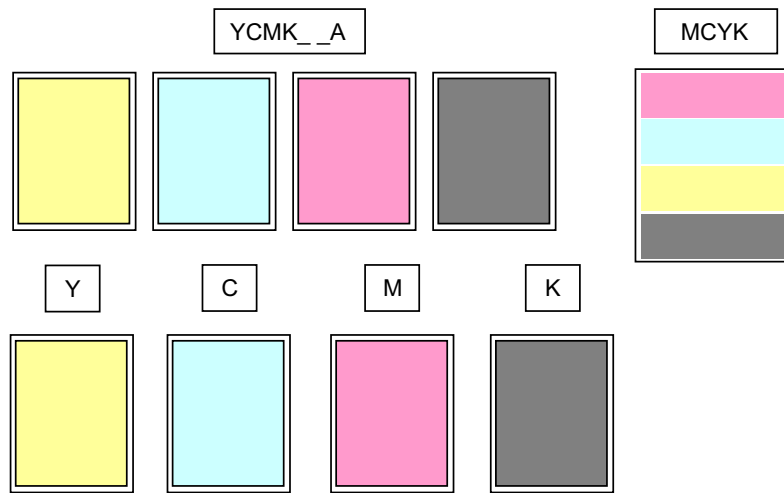

Fig. 7-11

## 1.4.15 Sensitivity adjustment of density sensor (Function code 72)

### <Function>

This function allows you to print the patch data for density sensor sensitivity adjustment on the belt unit and measure the density with the density sensor. The characteristics of the density sensor are calculated based on the value measured by the density sensor, and the parameter is adjusted upon color density adjustment.

### <Operating procedure>

- (1) Press the ▲ or ▼ button to display “MAINTENANCE 72” on the LCD in the initial state of the maintenance mode. Then, press the **OK** button. “PLEASE WAIT” is displayed on the LCD.
- (2) When the parameter is obtained without errors, the machine returns to the initial state of the maintenance mode.

When an error message is displayed on the LCD, take the measures described in the table below.

Error message	Measure
FAILED	Remove the error factors with the following operations and press the <b>Go</b> button to clear the error. <ul style="list-style-type: none"><li>- Re-insert the toner cartridge in the correct position.</li><li>- Replace the toner cartridge.</li><li>- Replace the drum unit.</li><li>- Replace the belt unit.</li><li>- Replace the registration sensor holder ASSY.</li></ul>
TONER EMPTY # *	Replace the empty toner cartridge and press the <b>Go</b> button to clear the error. Perform the sensitivity adjustment of the density sensor again.
Cover is Open	Close the top cover.
Replace Toner	Replace the toner cartridge.
No Paper	Replenish paper, and press the <b>Go</b> button to clear the error.
Jam Tray1	Remove the jammed paper, and press the <b>Go</b> button to clear the error.
Jam Rear	Remove the jammed paper, and press the <b>Go</b> button to clear the error.

\* # indicates the toner color (Y, M, or C) of which cartridge became empty.

## 1.4.16 Setting by country (Function code 74)

### <Function>

This function allows you to customize the EEPROM according to language, function settings, and worker switch settings.

#### **Note:**

If you replace the main PCB, be sure to carry out this procedure.

### <Operating procedure>

- (1) Press the ▲ or ▼ button to display “MAINTENANCE 74” on the LCD in the initial state of the maintenance mode. Then, press the **OK** button. The present customizing code is displayed.
- (2) Enter the upper 2 digits of the country setting code that you want to set.  
Press the ▲ or ▼ button to enter the first digit and press the **OK** button, and the cursor moves to the second digit.  
Press the ▲ or ▼ button to enter the second digit and press the **OK** button, and the cursor moves to the fourth digit.

#### **Note:**

When the upper 2 digits of an invalid country setting code are entered, the setting is ignored, and the cursor returns to the first digit.

- (3) Enter the lower 2 digits of the country setting code that you want to set.  
Press the ▲ or ▼ button to enter the third and fourth digits (in the range from 00 to 50) and press the **Go** button.
- (4) The new setting is saved, and “PARAMETER INIT” is displayed on the LCD. After the setting is saved, the machine returns to the initial state of the maintenance mode.

■ **Setting by country code list**

Country	HL-3040CN	HL-3070CW
USA	0001	0101
Canada	0002	0102
Chile	0036	0136
Argentina	---	0136
Germany	0004	0104
UK	0004	0104
France/Belgium/Netherlands	0005	0105
Italy	0016	0116
Iberia	0016	0116
Switzerland	0004	0104
Pan-Nordic	0007	0107
Russia	0004	---
EEU General	0004	0104
Israel	0017	---
Australia/New Zealand	0006	0106
Singapore	0006	0106
Gulf	0006	0106
Turkey	0006	0106
India	0045	0145
Korea	0006	---
China	0020	0120

\* Country codes are subject to change without notice.

**Note:**

The information in this page is as of July 2009.  
For information on the latest code settings, see the ROM/firmware information provided by Brother.

## 1.4.17 Sensitivity adjustment of registration mark sensor and check of belt surface (Function code 75)

### <Function>

This function makes the registration mark sensor to adjust its sensitivity compulsory. This allows you to check if the registration mark sensor works properly. This function makes the machine to check the surface of the belt unit by using the registration mark sensor as well.

### <Operating procedure>

- (1) Press the ▲ or ▼ button to display "MAINTENANCE 75" on the LCD in the initial state of the maintenance mode. Then, press the **OK** button. After "REGI\_SENS ADJUST" is displayed on the LCD, "REGI ADJ-BELTOFF" is displayed.
- (2) Press the ▲ or ▼ button to select the appropriate item.
- (3) Press the **Go** button, and then the sensitivity adjustment is started. Upon completion of this adjustment, the "OK" appears on the LCD.
- (4) Press the **Cancel** button to return to the machine to the initial state of the maintenance mode.

LCD	Description
REGI ADJ - BELTOFF	Adjust the sensitivity of the registration mark sensor when the belt unit is not operated. This is to check whether the registration mark sensor's operation is okay or not.
REGI BELT CHECK	Check whether there is no scratch on the surface of the belt unit within the detectable range of registration mark sensor.
REGI ADJ&CHECK	Adjust the sensitivity of the registration mark sensor when the belt unit is operated. (This adjustment is the same as the operation before the color registration.)

#### Note:

- If you press the **Go** button during the sensitivity adjustment or after the error message appears on the LCD, the sensitivity adjustment is started again.
- In the case that the error occurs, refer to the [next page](#) to check the error description and the way to solve it.

■ Error display when “REGI ADJ-BELTOFF” is executed

Error messages	Description	Solution
REGI_ADJ:NG	Registration mark sensor failure	Execute the adjustment of color registration (manual). (Refer to “Adjustment of color registration (Function code 66)” in this chapter.)
		Replace the belt unit.
		Replace the main PCB ASSY.
		Replace the engine PCB ASSY.
		Replace the registration sensor holder ASSY.

■ Error display when “REGI BELT CHECK” or “REGI ADJ&CHECK” is executed

Error messages	Description	Solution
REGI L:XX REGI R:OK	Error occurs on the registration mark L sensor.	Execute the adjustment of color registration (manual). If the error occurs again, replace the belt unit. (Refer to “Adjustment of color registration (Function code 66)” in this chapter.)
REGI L:OK REGI R:XX	Error occurs on the registration mark R sensor.	
REGI L:XX REGI R:XX	Error occurs on the registration mark L sensor and registration mark R sensor.	

\* XX shows the number of error times (1 to 999) when a scratch is detected on the surface of the belt unit. If the number of times is larger, the condition of the belt unit is worse.



## 1.4.18 Operational check of fans (Function code 78)

### <Function>

This function is to check whether each of fans is operating correctly or not. The operation of the following fans is checked respectively, and their operating states (rotation speed 100 %, rotation speed 50 %, or OFF) are displayed.

LCD	Parts name	Description
FU	Main fan	Evacuate hot air of the fuser unit.
PS	LV fan	Evacuate hot air of the Low-voltage power supply PCB.

### <Operating procedure>

- (1) Press the ▲ or ▼ button to display "MAINTENANCE 78" on the LCD in the initial state of the maintenance mode. Then, press the **OK** button.
- (2) Press the **Go** button to check the next item. For operation check, spin or stop fans actually on each item.
- (3) Press the **Cancel** button in any process of the display cycle. The machine returns to the initial state of the maintenance mode.

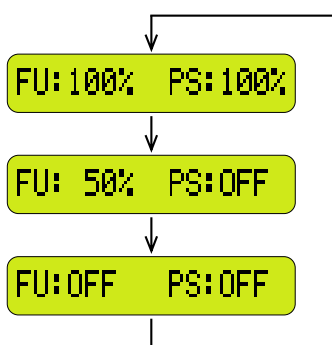

Fig. 7-12

### ■ Location of fans

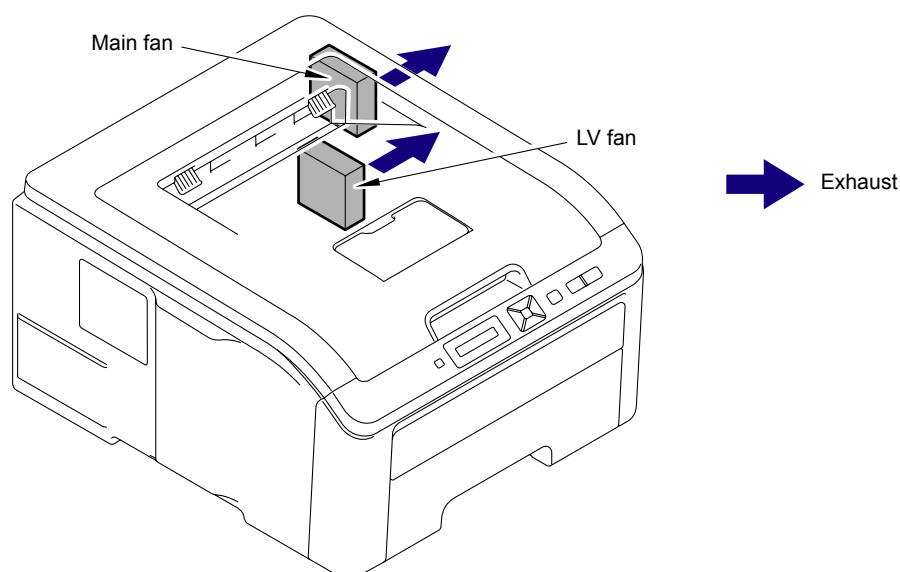

Fig. 7-13

### 1.4.19 Display of the machine's log (Function code 80)

#### <Function>

This function allows you to view the counter information. The display items are shown in the table below.

	LCD	Description
Serial	USB:	Serial number
Drum related items	CDRUM:	Number of accumulated rotations of cyan drum
	CDRM_PG:	Number of printed pages by cyan drum
	CDRM_CH:	Number of times the cyan drum unit has been replaced
	MDRUM:	Number of accumulated rotations of magenta drum
	MDRM_PG:	Number of printed pages by magenta drum
	MDRM_CH:	Number of times the magenta drum unit has been replaced
	YDRUM:	Number of accumulated rotations of yellow drum
	YDRM_PG:	Number of printed pages by yellow drum
	YDRM_CH:	Number of times the yellow drum unit has been replaced
	KDRUM:	Number of accumulated rotations of black drum
	KDRM_PG:	Number of printed pages by black drum
	KDRM_CH:	Number of times the black drum unit has been replaced
Toner related items	CTN_PG1:	Number of printed pages by cyan toner
	CTN_PG2:	Number of printed pages before previous reset of cyan toner
	CTN_ERM:	Remaining toner amount detected by the cyan toner sensor
	CTN_RRM:	Remaining toner amount calculated by the number of rotations of the cyan develop roller
	CTN_CH:	Number of times the cyan toner cartridge has been replaced
	MTN_PG1:	Number of printed pages by magenta toner
	MTN_PG2:	Number of printed pages before previous reset of magenta toner
	MTN_ERM:	Remaining toner amount detected by the magenta toner sensor
	MTN_RRM:	Remaining toner amount calculated by the number of rotations of the magenta develop roller
	MTN_CH:	Number of times the magenta toner cartridge has been replaced
	YTN_PG1:	Number of printed pages by yellow toner
	YTN_PG2:	Number of printed pages before previous reset of yellow toner
	YTN_ERM:	Remaining toner amount detected by the yellow toner sensor
	YTN_RRM:	Remaining toner amount calculated by the number of rotations of the yellow develop roller
YTN_CH:	Number of times the yellow toner cartridge has been replaced	
KTN_PG1:	Number of printed pages by black toner	
KTN_PG2:	Number of printed pages before previous reset of black toner	

	LCD	Description
Toner related items	KTN_ERM:	Remaining toner amount detected by the black toner sensor
	KTN_RRM:	Remaining toner amount calculated by the number of rotations of the black develop roller
	KTN_CH:	Number of times the black toner cartridge has been replaced
Replacing part related items	WTNR_PG:	Printed pages by waste toner box
	WTNR_CH:	Number of times the waste toner box has been replaced
	BCLN:	Number of accumulated rotations of the cleaning roller
	BELT_PG:	Printed pages by belt unit
	BELT_CH:	Number of times the belt unit has been replaced
	PFK1_PG:	Printed pages by paper feeding kit
	PFK1_CH:	Number of times the paper feeding kit has been replaced
	FUSR_PG:	Printed pages by fuser unit
FUSR_CH:	Number of times the fuser unit has been replaced	
Average print rate related items *1	CCVRGUSI:	Average cyan coverage % (Toner in use)
	CCVRGACC:	Average cyan coverage % (Accumulated)
	MCVRGUSI:	Average magenta coverage % (Toner in use)
	MCVRGACC:	Average magenta coverage % (Accumulated)
	YCVRGUSI:	Average yellow coverage % (Toner in use)
	YCVRGACC:	Average yellow coverage % (Accumulated)
	KCVRGUSI:	Average black coverage % (Toner in use)
	KCVRGACC:	Average black coverage % (Accumulated)
Print pages related items	TTL_PG:	Total number of printed pages
	TTL_CO:	Total number of color printed pages
	TTL_MO:	Total number of monochrome printed pages
	TTL_CI:	Cyan printed pages
	TTL_MI:	Magenta printed pages
	TTL_YI:	Yellow printed pages
	TTL_KI:	Black printed pages
Picked-up pages by tray	TR1_PG:	Number of pages picked up from the paper tray
	MN_PG:	Number of pages picked up from the manual feed slot
Picked-up pages by paper size	A4+LTR:	Number of A4/Letter size sheets picked up
	LG+A4L:	Number of Legal/A4 long size sheets picked up
	B5+EXE:	Number of B5/Executive size sheets picked up
	ENVLOP:	Number of envelopes picked up
	A5:	Number of A5 size (including A5R) sheets picked up
	OTHER:	Number of other-size (including JIS B6) sheets picked up

\*1 Average print rate: Print area/ printable area

	LCD	Description
Print pages by paper type <sup>*2</sup>	PLTNRE:	Printed pages of plain, thin, and recycled paper
	TKTRBD:	Printed pages of thick, thicker, and bond paper
	ENVTYP:	Printed pages of envelope, envelope thick, and envelope thin
	HAGAKI:	Printed pages of Hagaki
	LABEL:	Printed pages of label
Developing bias related items	CDEV_BIAS:	Cyan developing bias voltage (Unit:V)
	MDEV_BIAS:	Magenta developing bias voltage (Unit:V)
	YDEV_BIAS:	Yellow developing bias voltage (Unit:V)
	KDEV_BIAS:	Black developing bias voltage (Unit:V)
Power distribution time	POWER:	Power distribution time
	PWRCNT:	Number of times that the power is turned ON
Jam related items	TTL_JAM:	Total number of times when a jam occurs
	TR1_JAM:	Number of times when a jam occurs at the paper tray
	IN_JAM:	Number of times when a jam occurs inside the machine
	RE_JAM:	Number of times when a jam occurs at the ejecting
Number of error occurrences	HODN_ER:	Number of times when discharge detection error occurs due to smear on the corona wire
	FUSR_ER:	Number of times that fuser unit error occurs
	MTLK_ER:	Number of times that motor lock error occurs (Not used)
Error log related items	MACHINEERR_###: <sup>*3</sup>	Machine error ###: Error code/number of occurrences
	ENGERR###: <sup>*4</sup>	Engine error ###: Error level (2 bytes), large classification code (2 bytes), detailed classification code (2 bytes)

<sup>\*2</sup> The recording paper type specified in the printer driver setting. It is not necessarily matched with the type of the actually fed paper.

<sup>\*3</sup> 01 to 10 are entered in ## in chronological order. When you press the **OK** button as the machine error history is displayed, the page counter values when the errors occurred are displayed. When you press the **OK** button again, the machine error history is displayed again.

**Note:**

The error data items stored in the error history are different from those in the second page of Printer Settings.

<sup>\*4</sup> 01 to 10 are entered in ## in chronological order. When you press the **OK** button as the engine error history is displayed, TM: elapsed time (minute) from the previous error and BT: the number of times when the power is ON are displayed. When you press the **OK** button again, the engine error history is displayed again.

### <Operating procedure>

- (1) Press the ▲ or ▼ button to display “MAINTENANCE 80” on the LCD in the initial state of the maintenance mode. Then, press the **OK** button.
- (2) Each time the **Go** button is pressed, next log information item appears on the LCD in the order. If pressing the **Back** button, the previous log information appears.
- (3) Press the **Cancel** button to return the machine to the initial state of the maintenance mode.

#### **Note:**

If you press the **OK** button while an error code of MACHINEERR or ENGERR is displayed on the LCD, you can check the page counter value at the time when this error occurred. Press the **OK** button again to return to the error log display.

## 1.4.20 Error code indication (Function code 82)

### <Function>

This function displays an error code of the machine on the LCD.

### <Operating procedure>

- (1) Press the ▲ or ▼ button to display "MAINTENANCE 82" on the LCD in the initial state of the maintenance mode. Then, press the **OK** button. The machine displays "MACHINE ERROR XX" on the LCD.
- (2) Press the **Cancel** button to return the machine to the initial state of the maintenance mode.

## 1.4.21 Developing bias voltage correction (Function code 83)

### <Function>

This function performs developing bias voltage correction to fix the density of each color toner when printed color is not correct.

#### Note:

Before this function is performed, there is a need that the **Sensitivity adjustment of density sensor (maintenance mode 72)** has been done more than once. When performing this maintenance mode 83 after replacing the main PCB, make sure to perform the **Sensitivity adjustment of density sensor (maintenance mode 72)** first.

### <Operating procedure>

- (1) Press the ▲ or ▼ button to display “MAINTENANCE 83” on the LCD in the initial state of the maintenance mode. Then, press the **OK** button. The machine displays “PLEASE WAIT” on the LCD and starts the developing bias voltage correction.
- (2) Upon completion of the developing bias voltage correction, the machine returns to the initial state of the maintenance mode.

When any of the following error messages is displayed, take a relevant measure given in the table below.

Error message	Measure
FAILED	Remove the error factors with the following operations and press the <b>Go</b> button to clear the error. <ul style="list-style-type: none"><li>- Re-insert the toner cartridge in the correct position.</li><li>- Replace the toner cartridge.</li><li>- Replace the drum unit.</li><li>- Replace the belt unit.</li><li>- Replace the registration sensor holder ASSY.</li></ul>
TONER EMPTY # *	Replace the empty toner cartridge and press the <b>Go</b> button to clear the error. Perform the developing bias voltage correction again.
Cover is Open	Close the top cover.
Replace Toner	Replace the toner cartridge.
No Paper	Replenish paper, and press the <b>Go</b> button to clear the error.
Jam Tray1	Remove the jammed paper, and press the <b>Go</b> button to clear the error.
Jam Rear	Remove the jammed paper, and press the <b>Go</b> button to clear the error.

\* # indicates the toner color (Y, M, or C) of which cartridge became empty.

#### Note:

Any panel operation is invalid during the developing bias voltage correction.

## 1.4.22 Exit from the maintenance mode (Function code 99)

### <Function>

This function allows you to exit from the maintenance mode. If the error related to the fuser unit occurs, the error is cleared. (Refer to “2.5 How to Recover from Errors of the Fuser Unit” in this chapter.)

### <Operating procedure>

- (1) Press the ▲ or ▼ button to display “MAINTENANCE 99” on the LCD in the initial state of the maintenance mode. Then, press the **OK** button. The machine exits from the maintenance mode and return to the ready state.



## 2. OTHER SERVICE FUNCTIONS

### 2.1 Not-disclosed-to-users Function Menus Enabled by Pressing Button (s) When Turning the Machine On

The following settings and functions will be available by holding down the specified button (s) while turning the machine on.

#### ■ Press one button when turning the machine on

Panel operation	Function
<b>Go</b>	Not used
<b>Secure Print</b>	Not used
<b>Back</b>	Not used
▼ ( - )	Hex dump mode*
▲ ( + )	Not used
<b>OK</b>	Don't use
<b>Cancel</b>	Not used

\* You can print data from the computer as hexadecimal code. It is useful to analyze print data itself whether it is okay or not.

#### ■ Press two buttons at the same time when turning the machine on

Panel operation		Function
<b>OK</b>	<b>Back</b>	Don't use
<b>Go</b>	▲ ( + )	Not used
<b>Go</b>	<b>Back</b>	Engine non-startup mode*
▼ ( - )	▲ ( + )	Don't use
▼ ( - )	<b>OK</b>	Don't use
<b>Go</b>	<b>OK</b>	Not used
<b>Go</b>	<b>Cancel</b>	Flash ROM updates mode (UPD file/Model classification is available.)
<b>OK</b>	▲ ( + )	Obtain the wireless LAN MAC address (Ethernet address). (HL-3070CW only)

\* This mode is to start-up the machine without using the engine. When the error related to the engine occurs, you can ignore the error and get the error history or the other counter information though it is impossible to print. When the machine doesn't work in case that the connection failure between the main controller and the engine controller occurs, it is possible to update the main controller itself to recover from the failures.

■ Press the ▲ or ▼ button as holding down the Go button in the ready state

Panel operation		Function
<b>Go</b>	▲ ( + )	Parts life reset mode for the periodical replacement parts (Refer to “2.3 Parts Life Reset Function” in this chapter.)
<b>Go</b>	▼ ( - )	Not-disclosed-to-users functions (Refer to “1.4.9 Not-disclosed-to-users functions (Function code 45)” in this chapter.)

■ Press the Cancel button as holding down the Secure Print button while the top cover is opened

Panel operation		Function
<b>Secure Print</b>	<b>Cancel</b>	Develop roller counter reset mode (Refer to “2.2 Develop Roller Counter Reset Function” in this chapter.)

## 2.2 Develop Roller Counter Reset Function

This function is to manually perform the operation same as the one when a toner cartridge is replaced with a new one. The purpose of this function is to provide a means to resolve an error when a new toner cannot be recognized by the product, and the LCD display fails to be cleared.

### ■ Pressing the two buttons at the same time while the top cover is opened

Panel operation		Function
<b>Secure Print</b>	<b>Cancel</b>	Menus of the develop roller counter reset

#### <Operating procedure>

Cover is Open



K. TNR-STD



- (1) Press the **Secure Print** and **Cancel** buttons at the same time when the top cover is open.
- (2) "K. TNR-STD" appears on the LCD. Press the ▲ or ▼ button to select the appropriate toner cartridge, and then press the **OK** button.

LCD	Description
K. TNR-STD	Reset the develop roller counter of standard black toner cartridge.
K. TNR-STR	Reset the develop roller counter of starter black toner cartridge.
C. TNR-STD	Reset the develop roller counter of standard cyan toner cartridge.
C. TNR-STR	Reset the develop roller counter of starter cyan toner cartridge.
M. TNR-STD	Reset the develop roller counter of standard magenta toner cartridge.
M. TNR-STR	Reset the develop roller counter of starter magenta toner cartridge.
Y. TNR-STD	Reset the develop roller counter of standard yellow toner cartridge.
Y. TNR-STR	Reset the develop roller counter of starter yellow toner cartridge.

OK?



Accepted



Cover is Open

- (3) Once "OK?" appears on the LCD; press **OK** button.
- (4) The develop roller counter is reset.
- (5) The machine returns to the state in which the top cover is open.

#### Note:

- If there is no operation for 30 seconds or more, the machine automatically returns to step (1).
- While starter toner is also displayed on the LCD, make sure to select standard toner.

## 2.3 Parts Life Reset Function

This function is used to reset the relevant part counter and set +1 to the replacement counter when the user replaced the part with the correct procedure, and also used to forcibly reset the relevant part counter when an error cannot be resolved because the user did not replace the part with the correct procedure.

### ■ Pressing the two buttons in the ready state

Panel operation	Function
Press ▲ (+) as holding down Go button.	Menus of the parts life reset (Resets the counter of the periodical replacement parts or consumable parts and counts up the number of replacement times by 1.)

#### <Operating procedure>

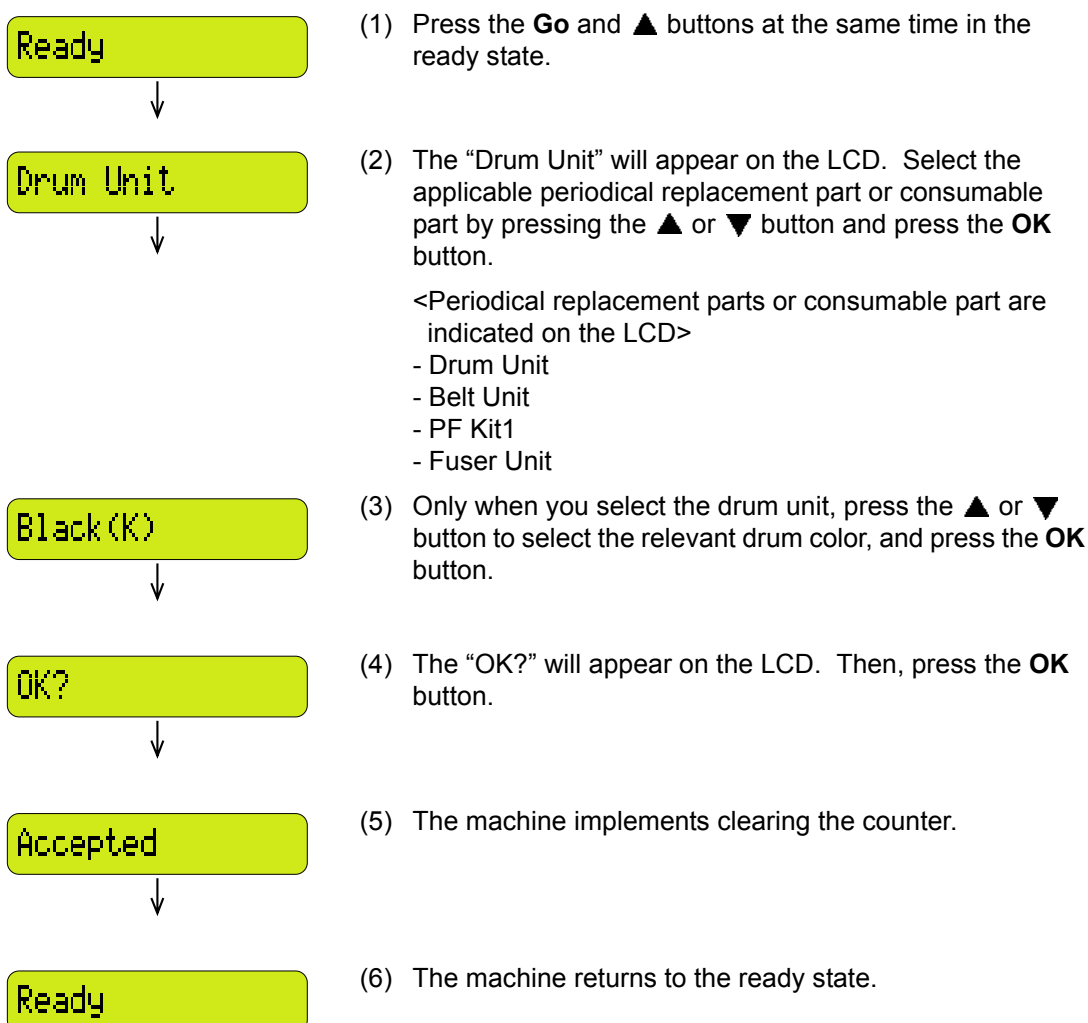

#### Note:

- All replacement parts are always indicated on the LCD even though their lives do not reach the end of life.
- The machine returns to the ready state automatically if no panel operation is implemented for 30 seconds.

## 2.4 Printout of Printer Settings

The machine prints "PRINTER SETTINGS." The printer settings of HL-3040CN consist of 3 pages, and those of HL-3070CW consist of maximum 4 pages (when both the wired LAN and wireless LAN are ON).

All pages have following items in common; Title, Model name, Serial number.

### <Operating procedure>

- (1) Press the **OK** button three times when the machine is in the ready state.
- (2) The machine displays "Printing" on the LCD, and starts to print. Upon completion of printing, the machine returns to the ready state.

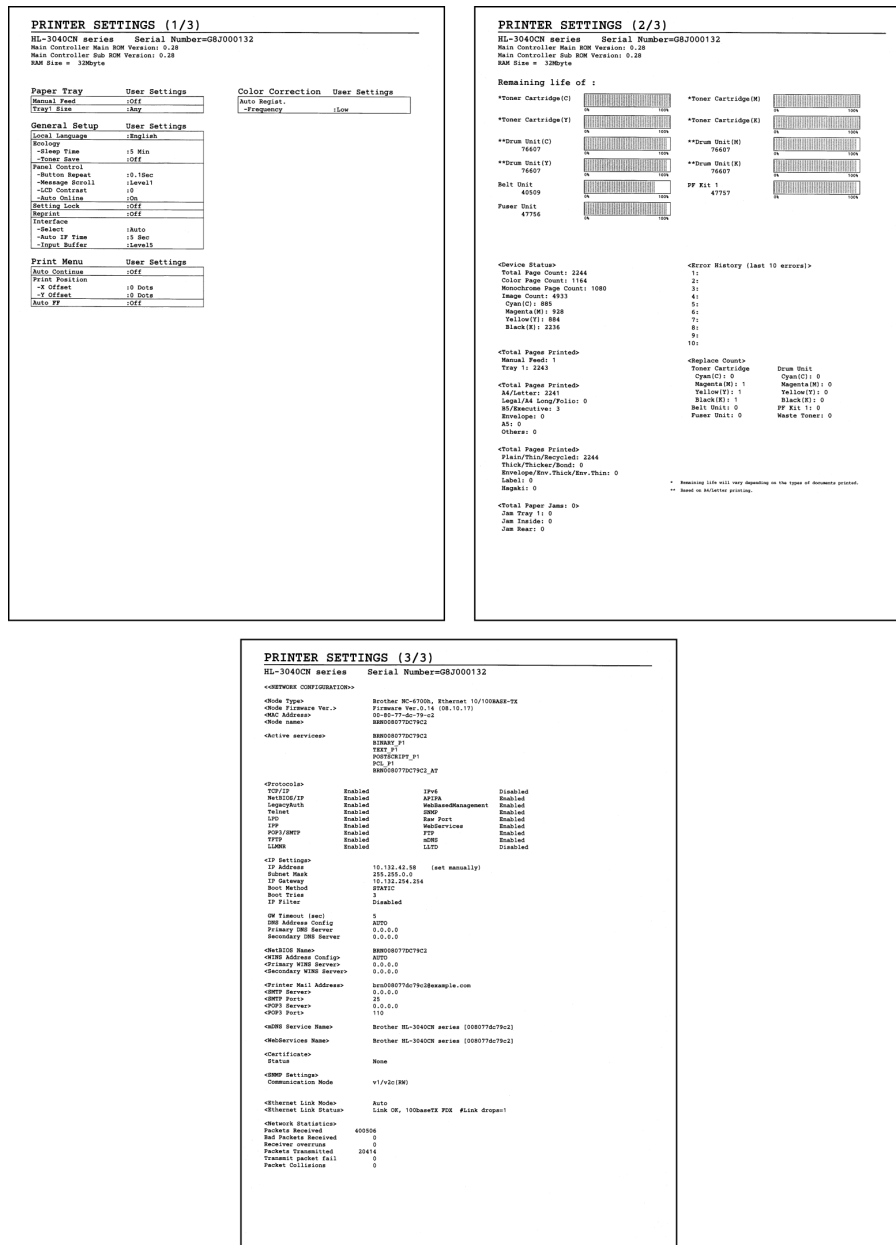

Fig. 7-14

## ■ Printer settings (Page 1)

This page includes various setting information of the machine. Each item is indicated when it fulfills the condition.

## ■ Printer settings (Page 2)

This page includes the printer information and the maintenance information in the following order.

### (1) Printer information

The following items are indicated in the order.

- 1) Main Controller Main ROM Version  
(Main controller firmware version)
- 2) Main Controller Sub ROM Version  
(Sub firmware (GDI or PCL/PS) version)
- 3) PictBridge Program Version (HL-3070CW only)
- 4) RAM Size (MB)

### (2) Maintenance information

#### 1) Consumable information/Periodical replacement part information

The printable pages remained for the part is indicated. Also, the percentage of life remained over the total printable pages is indicated in numerical value and bar graph.

A sample indication (PF Kit 1) is as follows:

From the top left, the parts name, the number of printable pages remained, and the percentage of life remained are indicated. The column graph shows the percentage of the remaining life, and one block indicates 2%.

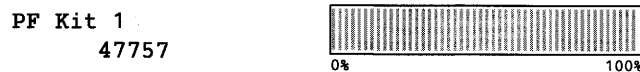

Fig. 7-15

The consumable parts and periodical replacement parts indicated are as follows:

- Toner Cartridge (K, Y, M and C are separated and total 4 cartridges)
- Drum Unit (K, Y, M and C are separated and total 4 units)
- Belt Unit
- PF Kit1
- Fuser Unit

■ **Life of drum unit**

**< How to read the drum unit life >**

- It initially indicates 100% and gradually decreases.
- It indicates 10% when the “Drum End Soon” appears on the LCD.

**< How to calculate the drum unit life >**

The drum unit life is based on the “drum counter” or the “number of drum rotations”. The drum counter is based on the total printed pages on each drum unit. This total printed pages should be reset every time you replace the drum unit with a new one. (Refer to “2.3 Parts Life Reset Function” in this chapter.) Basically this amount is equal to the assured printable pages of the drum unit.

If the developing bias voltage correction or color registration adjustment is performed frequently, however, only the number of drum rotations increases, and the “page counter based on the number of drum rotation” exceeds the “drum counter” based on the total printed page.

Refer to the calculation of the drum unit life based on the number of drum rotation below;

**< How to calculate the page counter >**

The number of drum rotations for the first page printed is about 28.

The number of drum rotations per one page for the second or later page printed (continuous printing) is 5.

Page counter based on the number of drum rotations = {Number of drum rotations for the first page printed + [Number of drum rotations per one page for the second or later page printed x (Number of pages in continuous printing - 1)]} / 28

(\* The number of drum rotations per one page continuous printing.)

Example: Starts to print when the machine is in the Ready state.

Continuous printing	Page counter based on the number of drum rotations (Pages)
1 page/job	{28 + [5 x (1 - 1)]} / 28 = 1
2 pages/job	{28 + [5 x (2 - 1)]} / 28 = 1.18
18 pages/job	{28 + [5 x (18 - 1)]} / 28 = 4.04

If you leave the machine without printing for a long time, the number of drum rotations is increasing because the developing bias voltage correction and the color registration are performed. If you print one page per one job every time after leaving the machine without printing for a long time, the drum unit life is shorter than usual.

The number of drum rotations required for the developing bias voltage correction = 55 rotations.

Example: Performs the developing bias voltage correction and starts to print after leaving the machine without printing for a long time.

Continuous printing	Page counter based on the number of drum rotations (Pages)
1 page/job	{55 + 28 + [5 x (1 - 1)]} / 28 = 2.96
2 pages/job	{55 + 28 + [5 x (2 - 1)]} / 28 = 3.14
18 pages/job	{55 + 28 + [5 x (18 - 1)]} / 28 = 6.00

The number of drum rotations required for the color registration = 27 rotations

Example: Performs the color registration adjustment and starts to print after leaving the machine without printing for a long time.

Continuous printing	Page counter based on the number of drum rotations (Pages)
1 page/job	{27 + 28 + [5 x (1 - 1)]} / 28 = 1.96
2 pages/job	{27 + 28 + [5 x (2 - 1)]} / 28 = 2.14
18 pages/job	{27 + 28 + [5 x (18 - 1)]} / 28 = 5.00

If the developing bias voltage correction and the color registration are performed continuously, the drum unit life is shorter.

2) Counter information, history information

The counter and history information related to the following item are included. When it reaches the maximum count, each item is no longer counted.

Total Page Count	The total number of printed pages. The maximum count is 1 million pages.
Color Page Count	The total number of printed pages with color toners (Y/M/C). The maximum count is 1 million pages.
Monochrome Page Count	The total number of printed pages with black toner only. The maximum count is 1 million pages.
Image Count Total	The total number of printed pages, and the total number of printed pages on each color (K/Y/M/C). The maximum count is 1 million pages.
Total Pages Printed	The total number of printed pages from each of the Manual Feed and the Tray 1. The maximum count is 1 million pages. This information is not cleared when the paper feeding kit is replaced.
Total Pages Printed	The total number of printed pages by paper size. Available paper sizes are A4/Letter, Legal/A4 Long/Folio, B5/Executive, Envelope, A5 and Others. The maximum count is 1 million pages.
Total Pages Printed	The total number of printed pages by paper type. Available paper types are Plain/Thin/Recycled, Thick/Thicker/Bond, Envelope/Env.Thick, Env.Thin, Label, and Hagaki. The maximum count is 1 million pages.
Total Paper Jams	The number of paper jam occurrence in each of the Tray1, Inside and Rear. The paper jam occurs when the machine is turned ON is not counted. The maximum count for each item is 65,535 times. Total number of jam occurrences is printed after "Total Paper Jams:."
Error History	The error history including the latest 10 errors and the number of pages when these errors occur are indicated. The errors such as Cover is Open, Manual Feed, No Paper XX and No Tray XX are not included.
Replace Count/ Periodical replacement part information	The number of replacement of each of Toner Cartridge (K/Y/M/C), Drum Unit (K/Y/M/C), Belt Unit, PF Kit 1, Fuser Unit, Waste Toner. The maximum count for each item is 255 times.

■ **Printer settings (Page 3, Page 4)**

These pages include various network settings information of the machine.

HL-3040CN	Page 3: Wired Network Information
HL-3070CW	LAN: Wired Enable setting = ON and WLAN Enable setting = ON Page 3: Wired Network Information Page 4: Wireless Network Information
	LAN: Wired Enable setting = ON and WLAN Enable setting = OFF Page 3: Wired Network Information Page 4: Not available
	LAN: Wired Enable setting = OFF and WLAN Enable setting = ON Page 3: Wireless Network Information Page 4: Not available
	LAN: Wired Enable setting = OFF and WLAN Enable setting = OFF Page 3 and 4: Not available



## 2.5 How to Recover from Errors of the Fuser Unit

How to recover from errors of the fuser unit is to use **Function code 99** in the maintenance mode.



### **WARNING**

When clearing an error, be sure that the fuser unit is cooled down sufficiently. If an error is cleared while the fuser unit is not cooled down, there is a possibility that the unit might be unable to be repaired.

## 2.6 Switching of Return Value of USB No./Support for Banding

### <Function>

This function allows you to switch USB transfer speed in the PictBridge mode, switch the return value of the USB No., and switch controls to resolve banding symptoms.

### <Operating procedure>

- (1) Press the **Go** button and **▼** button at the same time while the machine is in the ready state. "PB.USBSpeed" is displayed on the LCD.
- (2) Select one of the functions in the table below that you want to change the value using the **▲** or **▼** button and press the **OK** or **Go** button.

LCD	Description
PB.Speed=AUTO	Switching of the USB transfer speed in the PictBridge mode
USBNo.=ON	Changing return value of USB No.
PS.DitherType=0	Switching of PS Dither Pattern
Bd94CrctSub=ON	Switching of ON/OFF of 94-mm Banding measure transfer current correction/DCLN voltage correction
DP.ImpGray=ON	Switching of ON/OFF of DirectPrint Color mode-Improve Gray Color

An asterisk "\*" appears beside the current setting.

- (3) Select the value that you want to set using the **▲** or **▼** button and press the **OK** or **Go** button.
- (4) "Accepted" is displayed for approximately 2 second, and the machine goes back to the ready state.

#### Note:

After the setting of PB.Speed and USB No., turn OFF the power switch. (The change will not be applied until the power switch is turned OFF and ON.)

### <Details>

Item	Description	Setting
PB.Speed	If the digital camera which a user uses cannot be connected in the PictBridge mode, this function may make it possible.	PB.Speed=AUTO Adapts the speed to the capability of the USB device.
		PB.Speed=FULL Fixes the speed to Full Speed. The capability of the USB device is not depended on.
USBNo.	When the OS of the computer is Windows Vista®, it might not be able to obtain the serial No. of a USB device depending on the computer and USB device. To avoid this problem, the return value of the serial No. is switched to "0."	USBNo. =ON Returns the serial No. of the device.
		USBNo. =OFF Returns "0".

Item	Description	Setting
PS.DitherType	This function is to switch the dither pattern when printed letters and/or slanted lines are not smooth, and thin lines are rough or uneven.	PS.DitherType=0 Improves roughness of letters and slanted lines.
		PS.DitherType=1 Alleviates banding.
Bd94CrctSub	This function is to switch ON/OFF of the transfer current correction/ DCLN voltage correction control (Engine control) for the 94-mm position from the leading edge of each page.	Bd94CrctSub=ON Transfer current correction/DCLN voltage correction ON
		Bd94CrctSub=OFF Transfer current correction/DCLN voltage correction OFF
DP.ImpGray	This function is to switch ON/OFF of the print control for the gray color when other colors are slightly blended in the gray color or the gray color is uneven upon printing.	DP.ImpGray=ON Improves the symptom that other colors are slightly blended in the gray color.
		DP.ImpGray=OFF Improves the unevenness of the gray color.

# **CHAPTER 8**

## **CIRCUIT DIAGRAMS & WIRING DIAGRAM**

# CHAPTER 8

## CIRCUIT DIAGRAMS & WIRING DIAGRAM

This chapter provides the circuit diagrams and wiring diagram for the connections of the PCBs.

### CONTENTS

1. CIRCUIT DIAGRAMS .....	8-1
2. WIRING DIAGRAM .....	8-9





■ High-voltage Power Supply PCB Circuit Diagram SYS HITEK: SPH-8N35 (3/3)

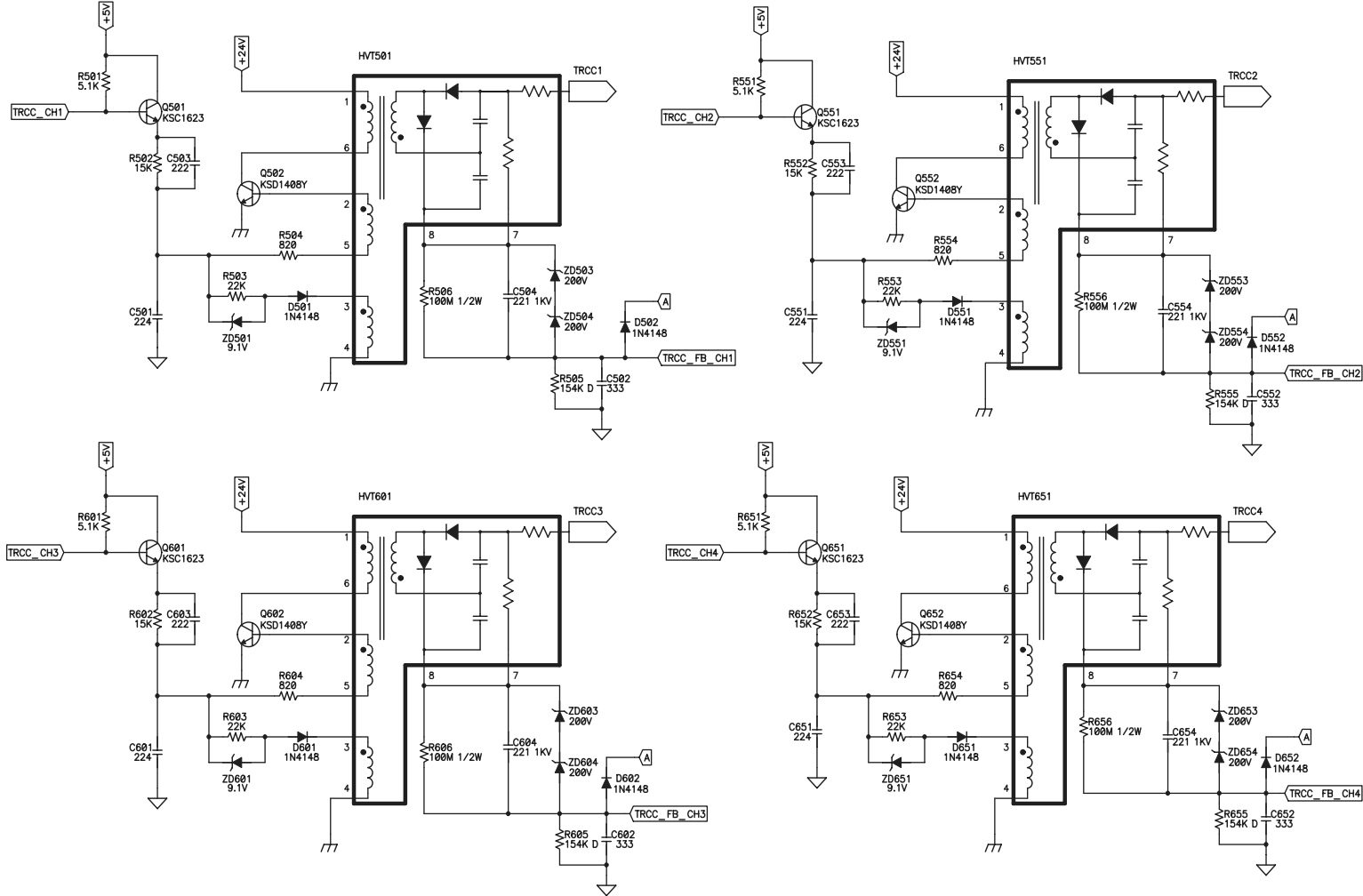



High-voltage Power Supply PCB Circuit Diagram MURATA: MPH3316 (1/3)

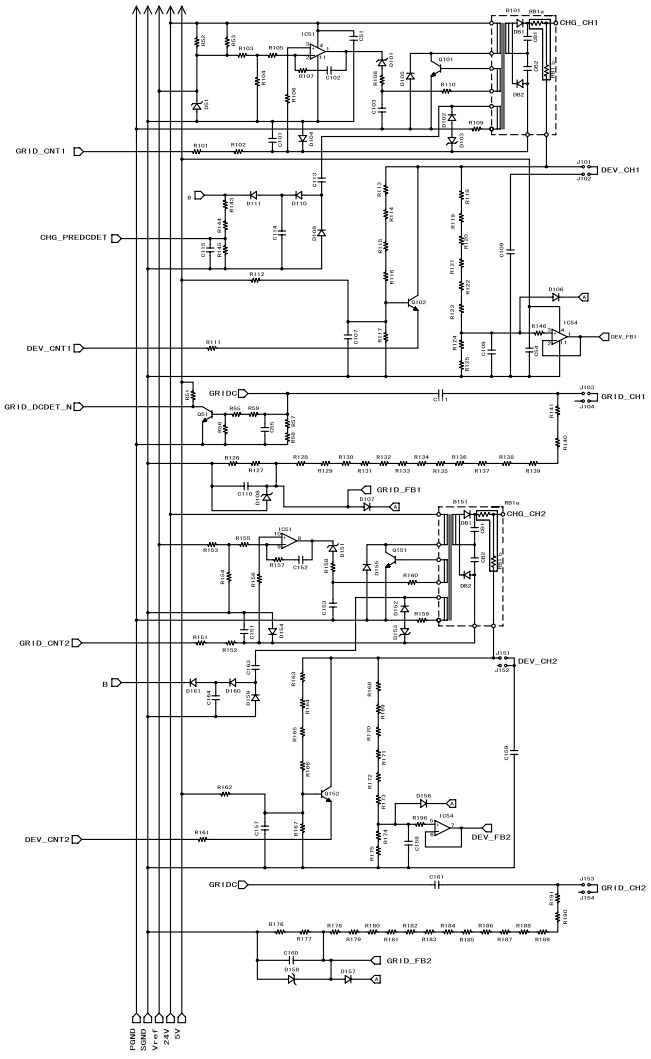
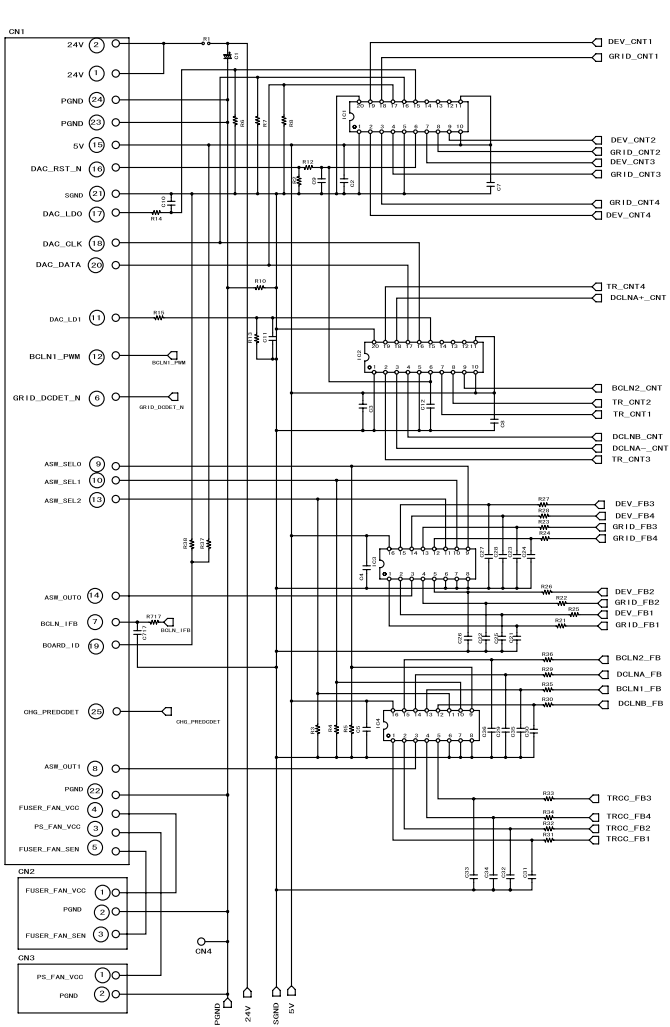

■ High-voltage Power Supply PCB Circuit Diagram MURATA: MPH3316 (2/3)

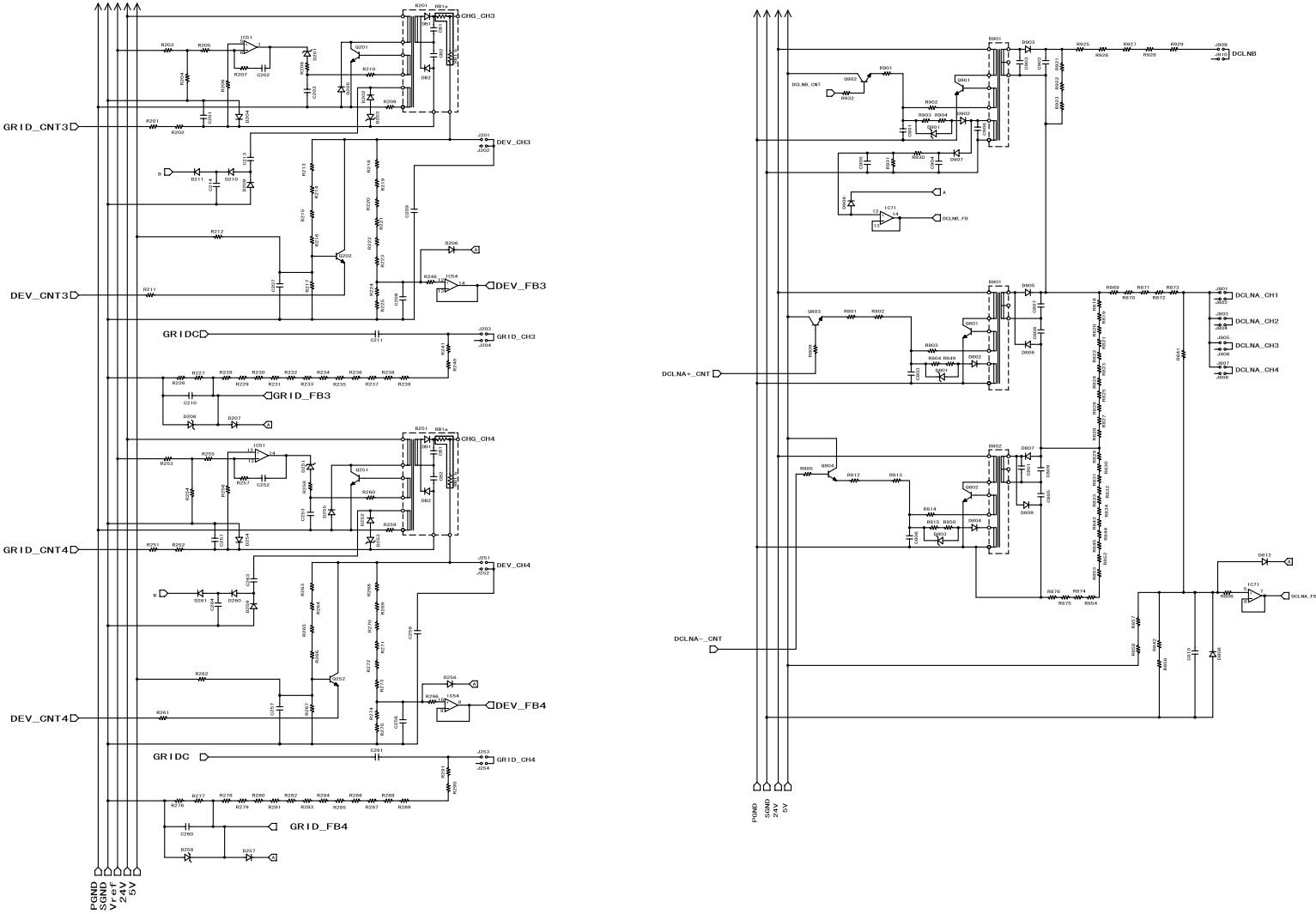

High-voltage Power Supply PCB Circuit Diagram MURATA: MPH3316 (3/3)

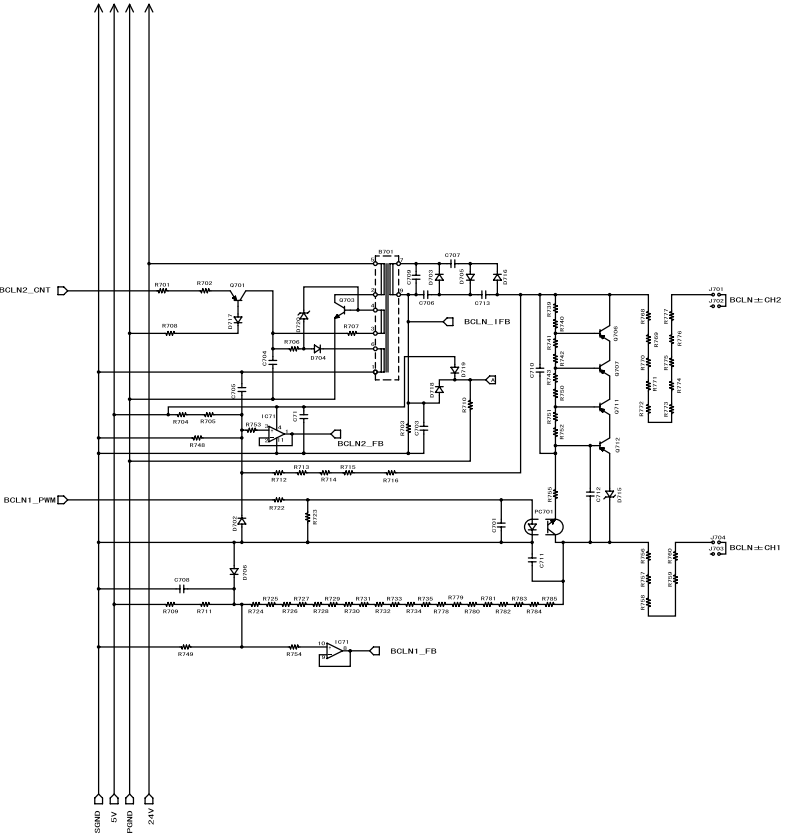
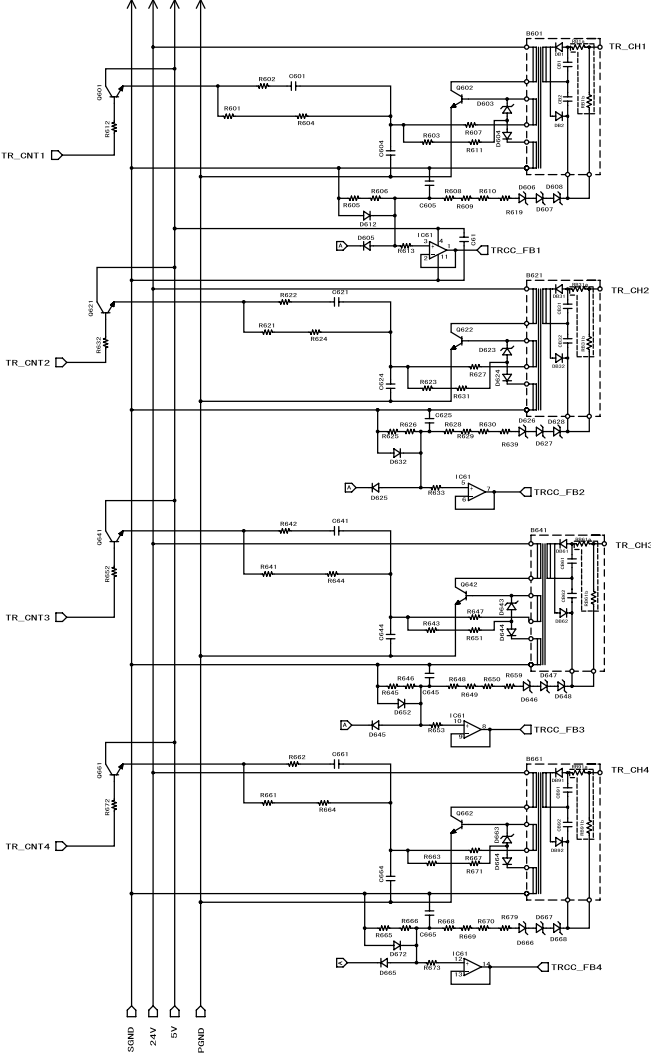

■ Low-voltage Power Supply PCB Circuit Diagram (100V)

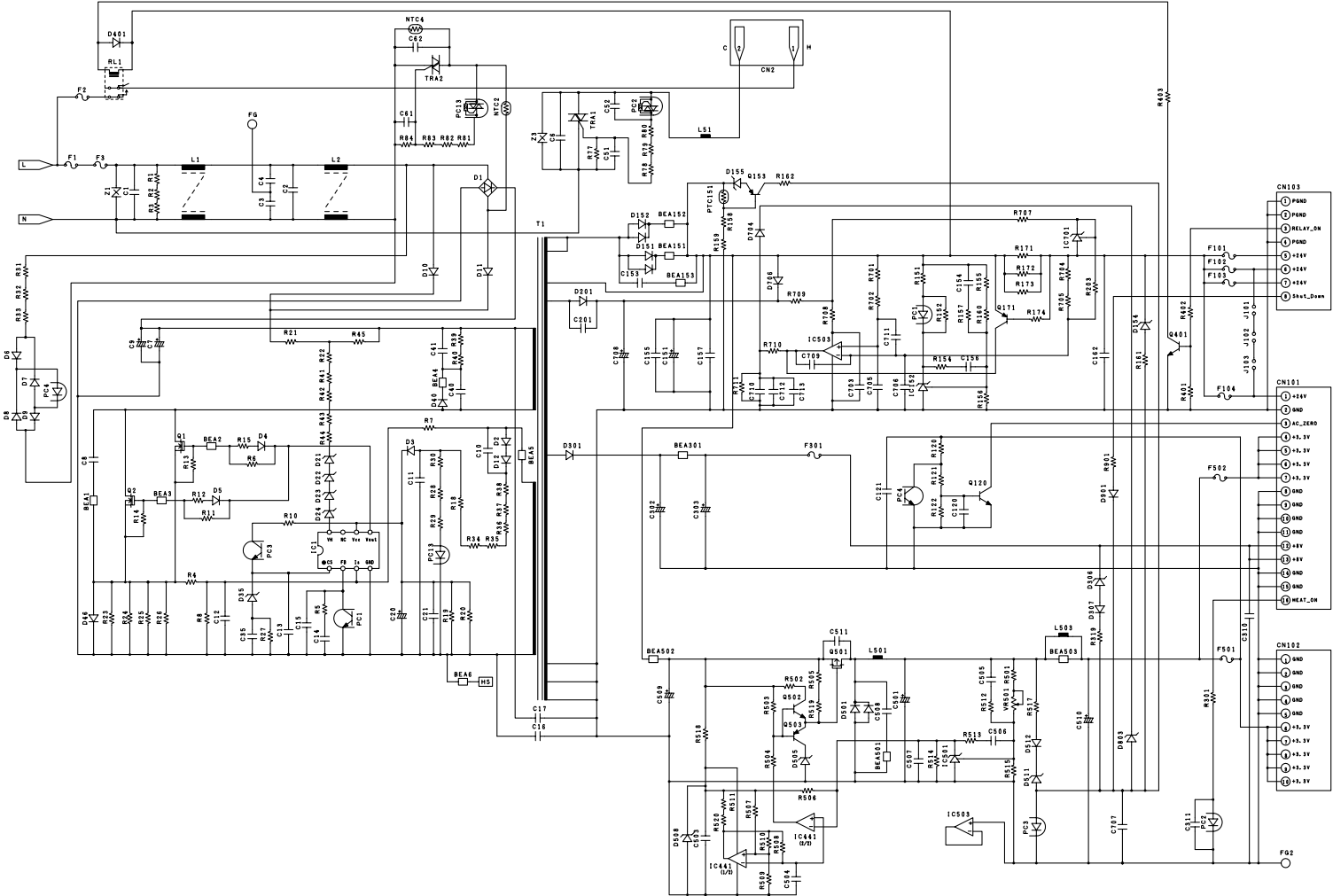

■ Low-voltage Power Supply PCB Circuit Diagram (200V)

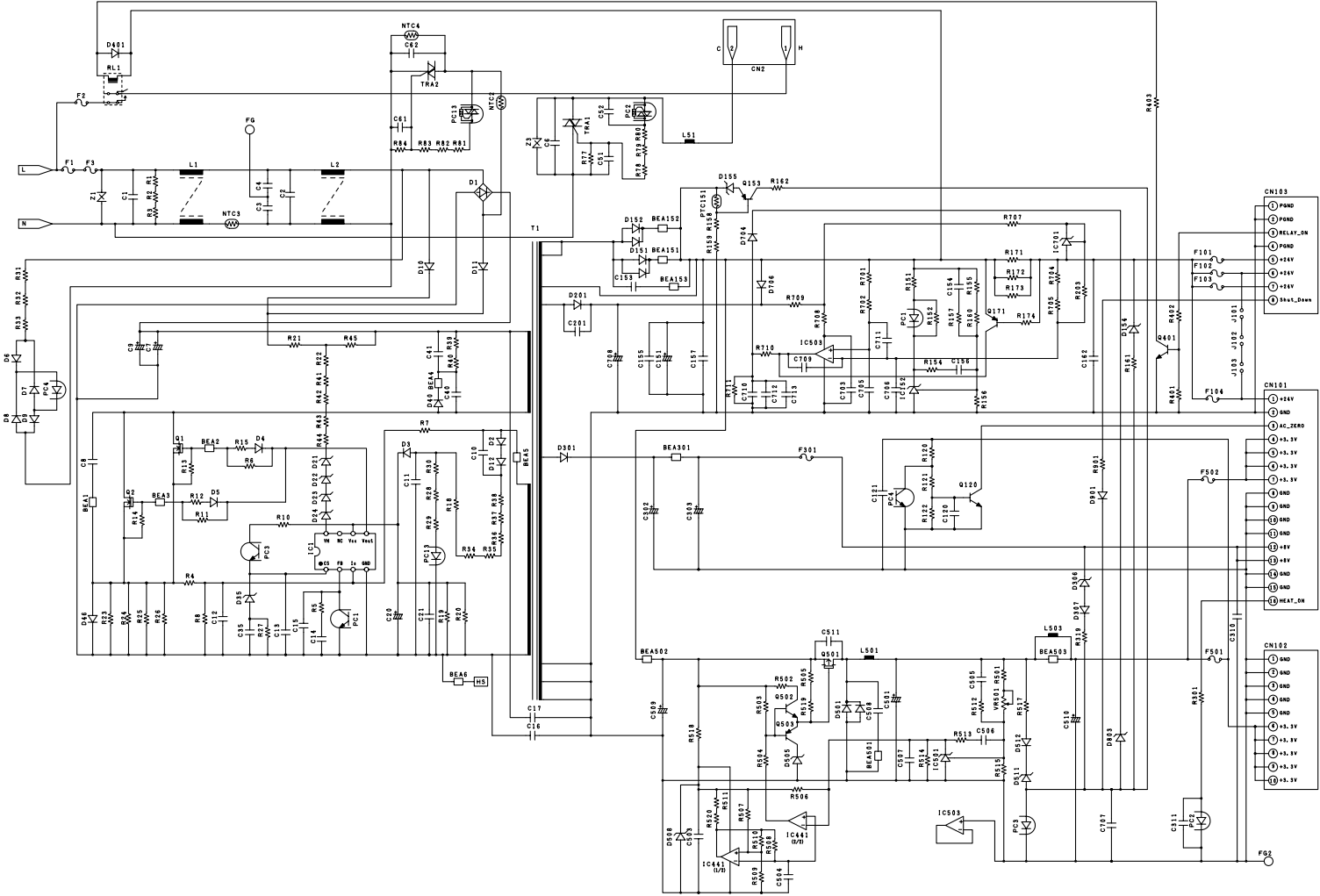

# 2. WIRING DIAGRAM

## ■ Wiring Diagram (1/2)

MAIN/PS/FUSER/  
LED-HEAD/PANEL

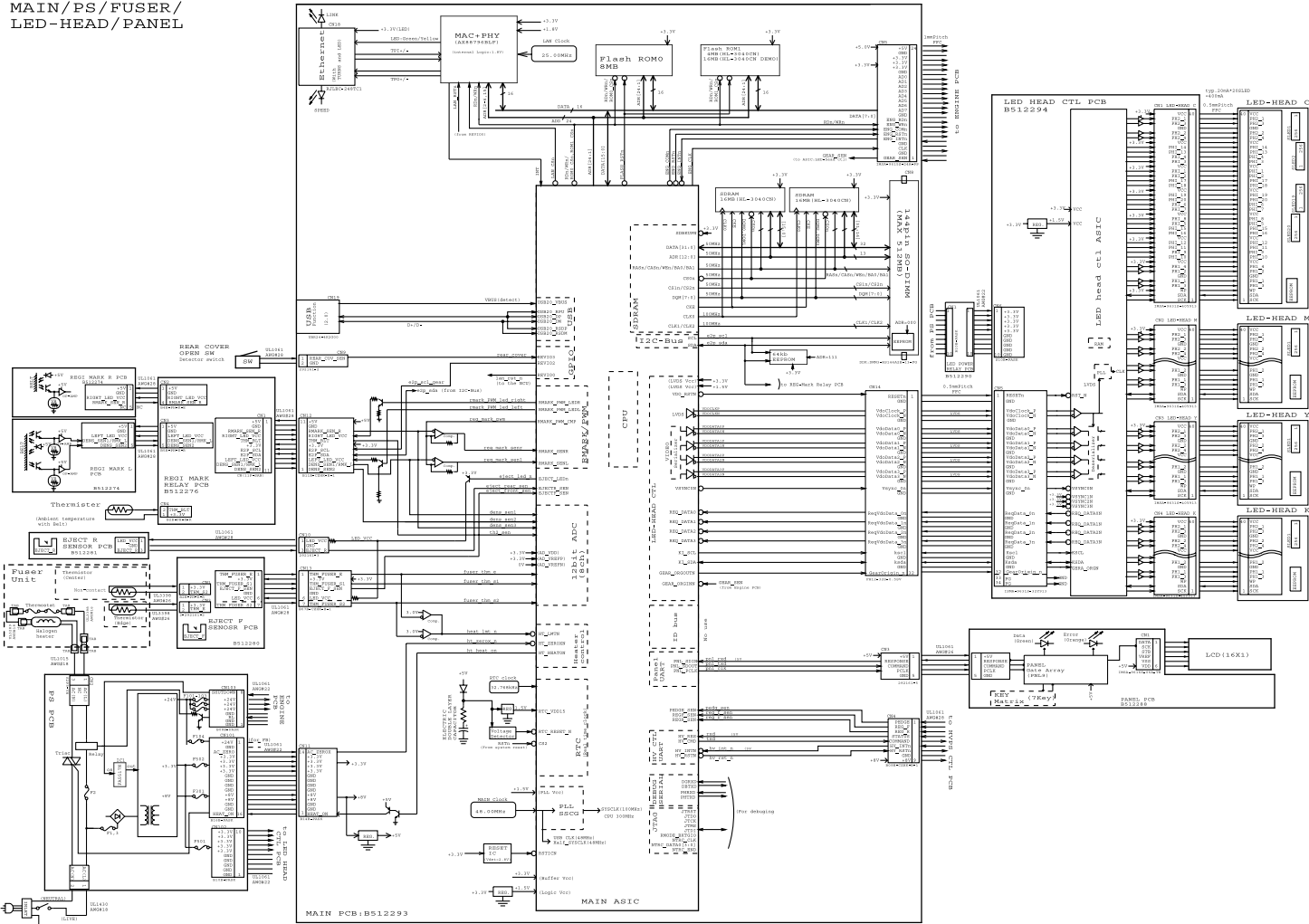

■ Wiring Diagram (2/2)

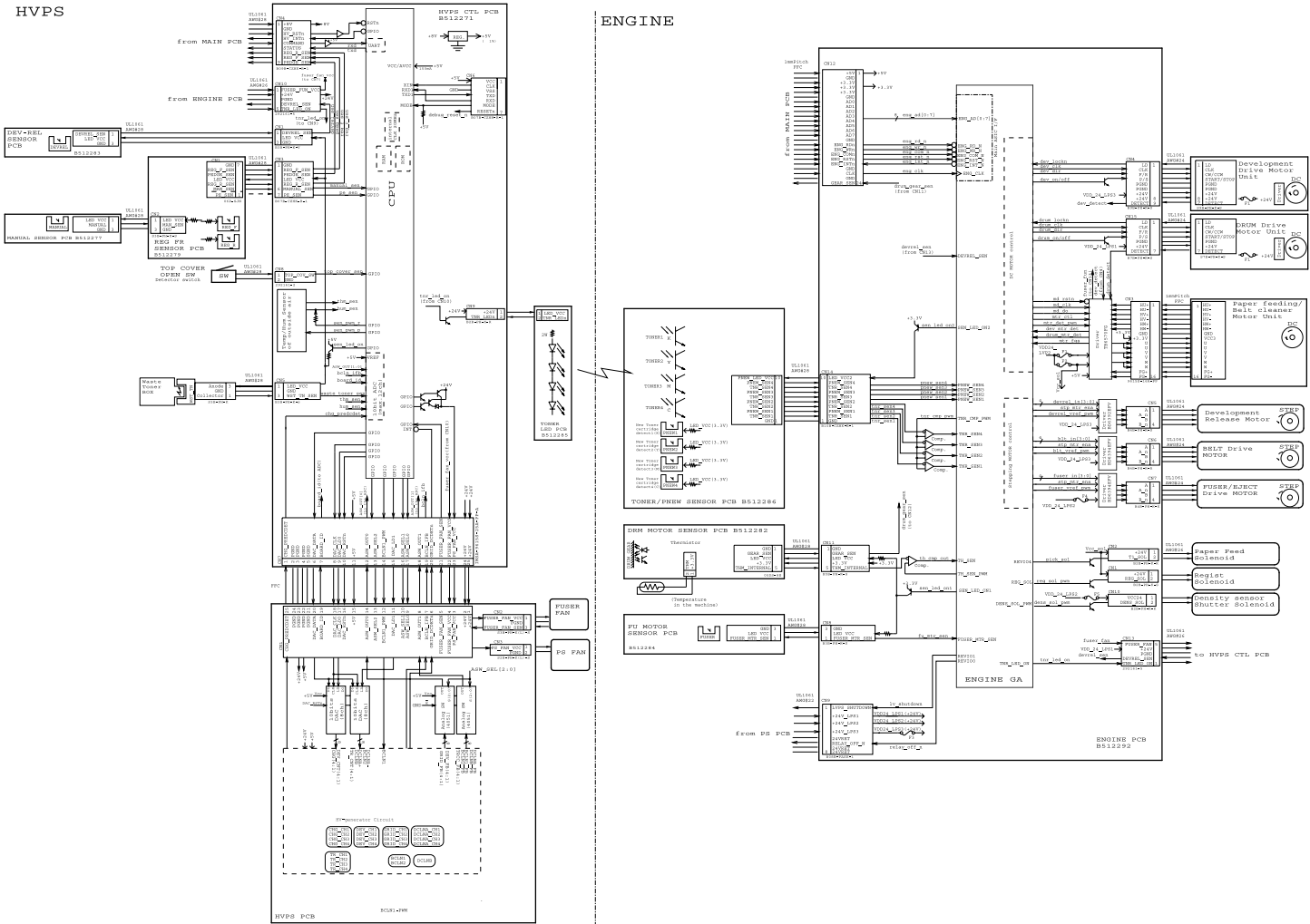

# **APPENDIX 1.**

## **WORKER SWITCH (WSW)**

This appendix describes the functions of the worker switches.

Each of the firmware switches has eight selectors. You should not allow end users to access all of those selectors, but you can allow them to access user-accessible selectors which are shaded in the worker switch tables in this appendix.



# WORKER SWITCH (WSW)

This appendix describes the functions of the worker switches.  
It is not allowed to access all of those selectors, but it is allowed to access the selectors **shaded** in the worker switch table.

## ■ Worker switch

WSW No.	Function	Refer to:
<b>WSW47</b>	Switching between high-speed USB and full-speed USB	<a href="#">App. 1-2</a>
<b>WSW54</b>	PictBridge command delay time (HL-3070CW only)	<a href="#">App. 1-2</a>
<b>WSW55</b>	Interval of time required for the developing bias voltage correction	<a href="#">App. 1-3</a>
<b>WSW56</b>	“Last Job Reprint” function setting	<a href="#">App. 1-4</a>
	Switching of the display for the coverage of toner cartridge	
	Switching of the CPU sleep mode	
<b>WSW59</b>	Enabling and disabling of transmission of USB serial number (SN)	<a href="#">App. 1-4</a>
<b>WSW63</b>	Font support for Israel	<a href="#">App. 1-5</a>
<b>WSW64</b>	Default paper size	<a href="#">App. 1-5</a>
<b>WSW65</b>	Default media type	<a href="#">App. 1-5</a>
	Support for Bond paper	
	Support for Hagaki	
	Support for Label	
<b>WSW66</b>	Reserved (Change of the setting is prohibited)	<a href="#">App. 1-6</a>
<b>WSW67</b>	Reserved (Change of the setting is prohibited)	<a href="#">App. 1-6</a>
<b>WSW68</b>	Reserved (Change of the setting is prohibited)	<a href="#">App. 1-6</a>
<b>WSW70</b>	Reserved (Change of the setting is prohibited)	<a href="#">App. 1-6</a>
<b>WSW73</b>	Reserved (Change of the setting is prohibited)	<a href="#">App. 1-6</a>

The functions and settings for each worker switch (WSW) are described below;

■ **WSW47 (Switching between high-speed USB and full-speed USB)**

Selector No.	Function	Setting and Specifications
1   7	Not used	
8	Switching between high-speed USB and full-speed USB	0: Auto switching between high-speed USB (ver. 2.0) and full-speed USB (ver. 1.1) 1: Fixed to full-speed USB (ver. 1.1)

■ **WSW54 (PictBridge command delay time (HL-3070CW only))**

Selector No.	Function	Setting and Specifications
1 2	PictBridge command delay time (HL-3070CW only)	No. 1 2 0 0: 100 msec (default) 0 1: 0 msec 1 0: 50 msec 1 1: 200 msec
3   8	Not used	

- **Selector 1 and 2: PictBridge command delay time (HL-3070CW only)**

These selectors specify the PictBridge command delay time that applies when the machine responds to the digital camera connected via PictBridge during negotiation. If the machine fails to receive data from the digital camera, change the delay time.

■ **WSW55 (Interval of time required for the developing bias voltage correction)**

Selector No.	Function	Setting and Specifications
1   8	Interval of time required for the developing bias voltage correction (hour)	0: The developing bias voltage correction is performed on each print job. 1-72: The developing bias voltage correction is performed when a print job occurs at specified time or later. (24: default) 73-254: Not allowed to set. 255: The developing bias voltage correction is not performed.

The setting example of the selector number is as follows;

No. 1 2 3 4 8 5 7 8

0 0 0 0 0 0 0 0: The developing bias voltage correction is performed on each print job.

0 0 0 1 1 0 0 0: The developing bias voltage correction is performed when a print job occurs after 24 hours (default value) or later.

0 0 0 1 0 0 1 0: The developing bias voltage correction is performed when a print job occurs after 72 hours or later.

1 1 1 1 1 1 1 1: The developing bias voltage correction is not performed.

- **Selector 1 to 8: Interval of time required for the developing bias voltage correction**

To keep the density of four colors evenly, the developing bias voltage correction is performed when a print job occurs at specified time or later.

■ **WSW56 ( Function setting 21 )**

Selector No.	Function	Setting and Specifications
1   2	Not used	
3	“Last Job Reprint” function setting	0: Invalid 1: Valid (default)
4   5	Not used	
6	Switching of the display for the coverage of toner cartridge	0: The coverage only for the current toner cartridge 1: The coverage for all toner cartridges which had been consumed
7	Not used	
8	Switching of the CPU sleep mode	0: Invalid 1: Valid (default)

**- Selector 3: “Last Job Reprint” function setting**

This selector prevents Reprint of important data such as the last printed confidential document.

**- Selector 6: Switching of the display for the coverage of toner cartridge**

This selector specifies the display for the coverage of toner cartridge. Setting this selector to “0”, the machine displays the coverage only for the current toner cartridge. If this selector sets to “1”, the machine displays the coverage for all toner cartridge which had been consumed.

**- Selector 8: Switching of the CPU sleep mode**

This selector specifies the CPU sleep mode ON or OFF.

■ **WSW59 (Enabling and disabling of transmission of USB serial number (SN))**

Selector No.	Function	Setting and Specifications
1	Enabling and disabling of transmission of USB serial number (SN)	0: Transmit USB serial No. (default) 1: Not transmit USB serial No.
2   8	Not used	

**- Selector 1: Enabling and disabling of transmission of USB serial number (SN)**

In the default, this machine transmits the USB serial number to the connected computer. If Windows Vista® runs on the computer, transmission of the USB serial number from this machine might cause a failure. In such a case, this selector is used to disable transmission.

■ **WSW63 (Font support for Israel)**

Selector No.	Function	Setting and Specifications
1   7	Not used	
8	Font support for Israel	0: Disable 1: Enable (default)

- **Selector 8: Font support for Israel**

To enable the font support for Israel, set this selector to "1".

■ **WSW64 (Setting the Default paper size)**

Selector No.	Function	Setting and Specifications
1   6	Not used	
7   8	Default paper size	No. 1 2 0 0: Letter 0 1: A4 1 0: Reserve 1 1: Reserve

■ **WSW65 (Setting the paper support)**

Selector No.	Function	Setting and Specifications
1 2	Default media type	No. 1 2 0 0: Plain Paper 0 1: Thin Paper 1 0: Reserve 1 1: Reserve
3	Support for Bond paper	0: Not supported 1: Supported
4	Support for Hagaki	0: Not supported 1: Supported
5	Not used	
6	Support for Label	0: Not supported 1: Supported
7 8	Not used	

■ **WSW66 (Reserved \*Change of the setting is prohibited)**

Selector No.	Function	Setting and Specifications
1   8	Reserved * Change of the setting is prohibited.	

■ **WSW67 (Reserved \*Change of the setting is prohibited)**

Selector No.	Function	Setting and Specifications
1   8	Reserved * Change of the setting is prohibited.	

■ **WSW68 (Reserved \*Change of the setting is prohibited)**

Selector No.	Function	Setting and Specifications
1   8	Reserved * Change of the setting is prohibited.	

■ **WSW70 (Reserved \*Change of the setting is prohibited)**

Selector No.	Function	Setting and Specifications
1   8	Reserved * Change of the setting is prohibited.	

■ **WSW73 (Reserved \*Change of the setting is prohibited)**

Selector No.	Function	Setting and Specifications
1   8	Reserved * Change of the setting is prohibited.	

## **APPENDIX 2.**

### **DELETION OF USER SETTING INFORMATION etc.**

This appendix provides instructions on how to delete user setting information etc. recorded in the machine.

# DELETION OF USER SETTING INFORMATION etc.

In this machine, the user setting information is stored in the EEPROM and flash memory of the main PCB. You can delete all the data listed below at a time with the procedure given below.

- Information related to Net
- User setting information
- Computer usage limit information (HL-3070CW only)

## <Operating procedure>

- (1) Disconnect the network cable from the printer.
- (2) Press the **+** or **-** button in the ready state until "Reset Menu" appears on the LCD.
- (3) Press the **OK** button. The "Reset Printer" will appear on the LCD.
- (4) Press the **+** and **Cancel** buttons at the same time. The "Setting Reset" will appear on the LCD.
- (5) Press the **OK** button. The "Reset Printer?" will appear on the LCD.
- (6) Press the **OK** button again, and the machine automatically restarts, the user setting information is deleted, and the machine goes back to the ready state.



# **APPENDIX 3.**

## **SERIAL NUMBERING SYSTEM**

# SERIAL NUMBERING SYSTEM

Each machine has a serial number label for the machine itself and property labels for some other parts. Refer to the information below for the meaning of the serial number and property codes and the location of each label.

## ■ Serial number labels for the machine itself

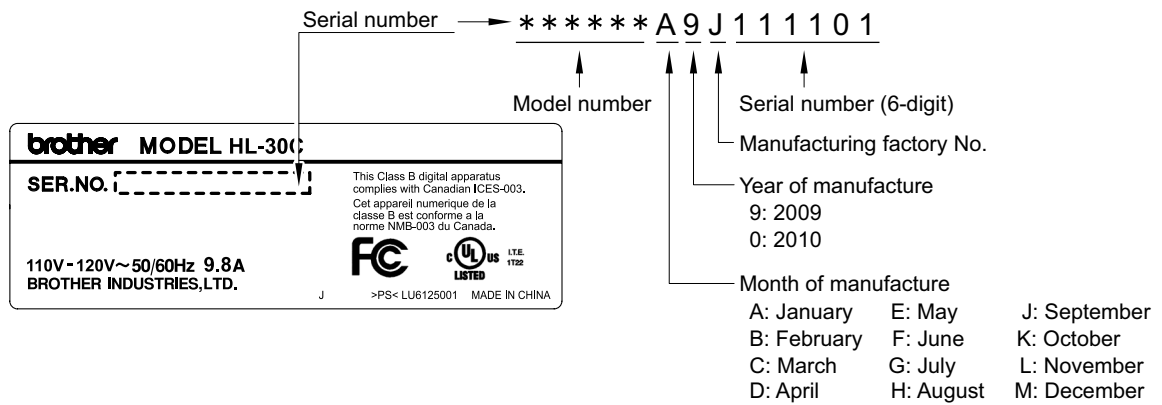

Fig. App 3-1

## <Location>

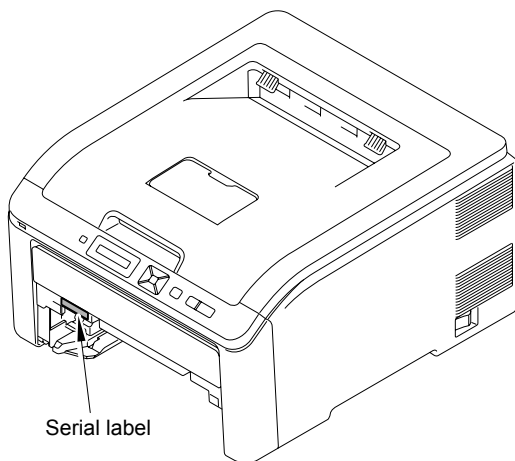

Fig. App 3-2

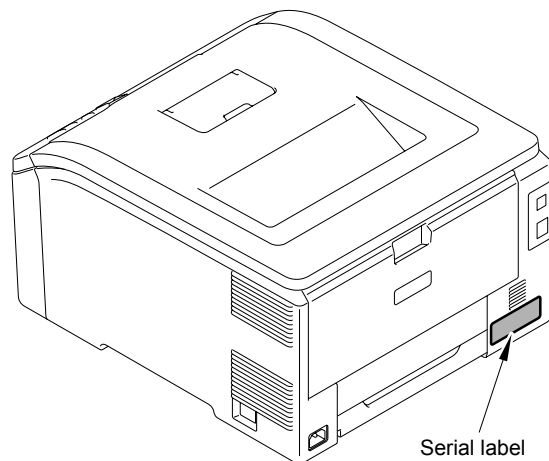

Fig. App 3-3

■ Serial number of the LED ASSY

<Print position>

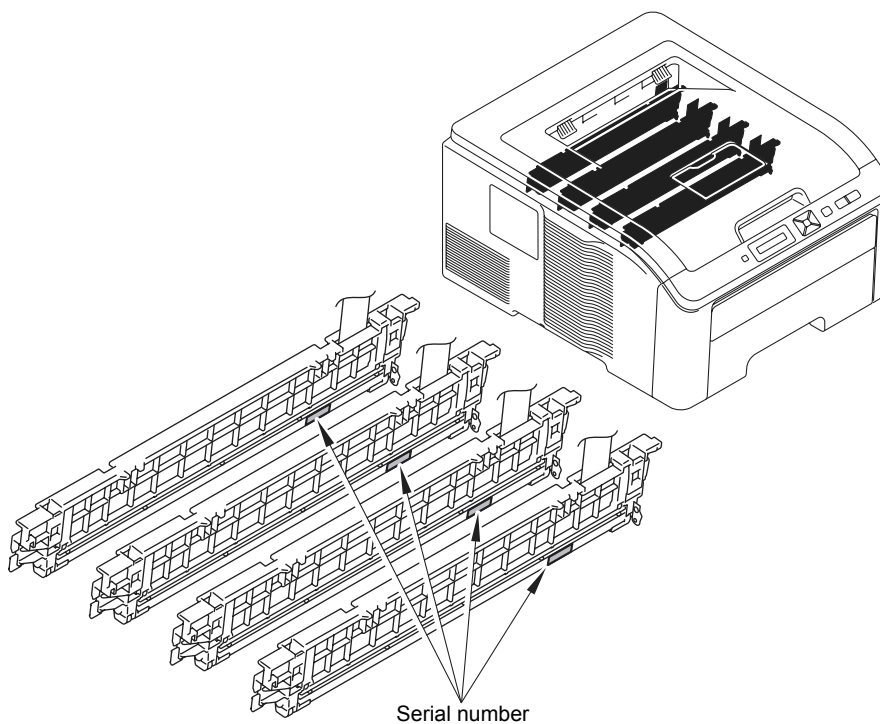

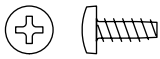
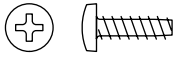
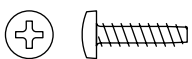

Fig. App 3-4

# **APPENDIX 4.**

## **SCREW CATALOGUE**

# SCREW CATALOGUE



## Taptite bind B

Taptite bind B M3x8	
Taptite bind B M3x10	
Taptite bind B M3x12	
Taptite bind B M4x12	

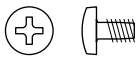
## Taptite bind S

Taptite bind S M3x5	
------------------------	--

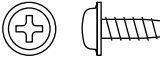
## Taptite cup B

Taptite cup B M3x8	
Taptite cup B M3x10	



## Screw bind

Screw bind M3x4	
--------------------	---

## Taptite cup S

Taptite cup S M3x6 SR	
--------------------------	---

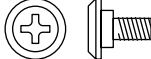
## Shoulder screw

Shoulder screw	
Shoulder screw M3	

## Taptite pan

Taptite pan B M4x14	
---------------------	--

## Screw pan (S/P washer)

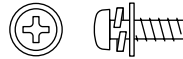
Screw pan (S/P washer) M4x8 DB	
Screw pan (S/P washer) B M3x10	

## Taptite pan (washer)

Taptite pan (washer) B M4x12DA	
-----------------------------------	---

# **APPENDIX 5.**

## **REFERENCES**

# REFERENCES

This page provides reference information.

It is possible to get the full instructions of the subjects by just clicking on the links below.

## **1. Machine specification**

(Refer to [“2. SPECIFICATIONS LIST”](#) in Chapter 1.)

## **2. Paper specification**

(Refer to [“2.5 Paper”](#) in Chapter 1.)

## **3. Error codes**

(Refer to [“2.1 Error Codes”](#) in Chapter 3.)

## **4. Error message**

(Refer to [“2.3 Error Cause and Remedy”](#) in Chapter 3.)

## **5. Pitch indicated in roller image**

(Refer to [“4.2 Pitch Indicated in Roller Image”](#) in Chapter 3.)

## **6. Periodical maintenance parts**

(Refer to [“3.1 Periodical Maintenance Parts”](#) in Chapter 4.)

## **7. Reset parts life**

(Refer to [“2.3 Parts Life Reset Function”](#) in Chapter 7.)

# **APPENDIX 6.**

## **GLOSSARY**



# GLOSSARY

## ■ ACRONYMS AND TECHNICAL TERMS

In this manual, the manual specific acronyms and technical terms are used in addition to the generally used ones. The table below contains typical acronyms and technical terms that are used throughout this manual.

APIPA	Automatic Private IP Addressing	K	Black (Color)
ASIC	Application Specific Integrated Circuit	LCD	Liquid Crystal Display
		LED	Light Emitting Diode
ASSY	Assembly	LED array	The long part which is a part of LED ASSY and emits LED beams
C	Cyan (Color)		
CN	Connector	LM hook	Lift-up Motion hook
CPU	Central Processing Unit	LV	Low Voltage
dB	decibel	LVPS	Low Voltage Power Supply
DEV	Development	M	Magenta (Color)
DIMM	Dual Inline Memory Module	MP	Multi-Purpose
dpi	dots per inch	N/A	Not Applicable
DX	Duplex	NC*	Network Circuit
EEPROM	Electronically Erasable and Programmable Read Only Memory	NVRAM	Nonvolatile Random Access Memory
		OPC	Organic Photo Conductor
FR	Feed Roller	PF	Paper Feed
FU	Fuser	PP gear	Pressure Plate gear
HEX	Hexadecimal	ppm	pages per minute
HUM	Humidity	PU	Pick-Up roller
HV	High Voltage	RAM	Random Access Memory
HVPS	High Voltage Power Supply	SP	Spare Parts
IEEE 1284	Institute of Electrical and Electronic Engineers 1284	TE	Toner Empty
		THM	Thermal
IF	Interface	TN	Toner
IPv4	Internet Protocol Version 4	TR	Transfer
IPv6	Internet Protocol Version 6	Y	Yellow (Color)

\* Excluding the acronym shown on the wiring diagram or circuit diagram.