

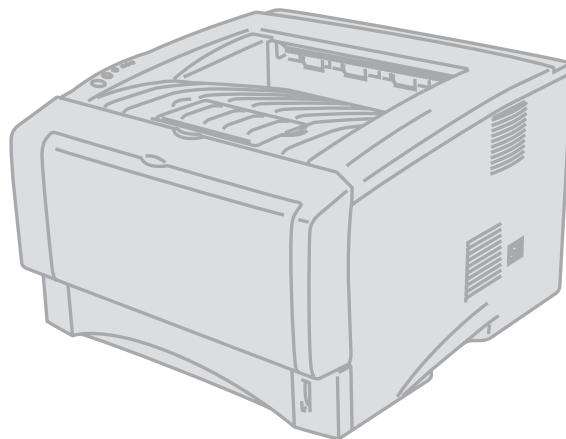

Brother Laser Printer **PARTS REFERENCE LIST**

**MODEL:
HL-5030/5040/5050/5070N**



Read this list thoroughly before maintenance work.

Keep this list in a convenient place for quick and easy reference at all times.

NOTE FOR USING THIS PARTS REFERENCE LIST

1. In the case of ordering parts, it needs mentioning the following items:

- (1) Code
- (2) Q'ty
- (3) Description
- (4) Symbol (PCB No., Revision , and Parts location mounted on the PCB.)

Note : No orders without Parts Code or Tool No. can be accepted.

< Example >

REF.NO.	CODE	Q'TY	DESCRIPTION	SYMBOL	REMARK

Revision No.: marked on the **main printed circuit board**.

B48K056 – 201 A



Revision No.: marked on the **power supply printed circuit board**.

Rev. A

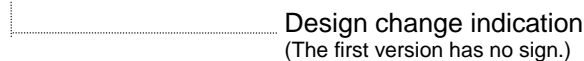

2. Design-changed parts :

If the parts are changed, any one of the following symbols is indicated in the REMARKS column.

CNG(cng) : The part is changed to a new part.

ADD(add) : The part is newly added.

DEL(del) : The part is deleted.

Symbol in capital letters indicates that the change is the latest one in the page.

3. The original of this list was made based on the information available in January 2003.

4. Parts are subject to change in design without prior notice.

CONTENTS

1.	<u>FRAME L/ DRIVE UNIT</u>	1
2.	<u>FRAME R UNIT</u>	1
3.	<u>FRAME UNIT</u>	3
4.	<u>LASER UNIT</u>	3
5.	<u>PAPER FEEDER</u>	5
6.	<u>MP UNIT</u>	5
7.	<u>PAEPR CASSETTE</u>	7
8.	<u>FIXING UNIT</u>	9
9.	<u>COVERS</u>	11
10.	<u>MAIN PCB</u>	13
11.	<u>ENGINE PCB</u>	15
12.	<u>LOW-VOTAGE POWER SUPPLY PCB</u>	15
13.	<u>HIGH-VOLTAGE POWER SUPPLY PCB</u>	17
14.	<u>ACCESSORIES</u>	17
15.	<u>PACKING MATERIALS</u>	19
16.	<u>PERIODICAL MAINTENANCE PARTS</u>	19

1. FRAME L/ DRIVE UNIT

REF.NO.	CODE	Q'TY	DESCRIPTION	SYMBOL	REMARK
1	LJ7695001	1	MAIN FRAME L UNIT 30		
1	LJ7363001	1	MAIN FRAME L UNIT 40		
1	LJ7603001	1	MAIN FRAME L UNIT 50		
1	LJ7692001	1	MAIN FRAME L UNIT 70N		
1-1	LJ7381001	1	MAIN MOTOR ASSY ZL2		
1-2	LJ7386001	1	F/R SOLENOID ASSY		
1-3	LJ7391001	1	P/R SOLENOID ASSY		
1-4	LJ5014001	1	SOLENOID RELEASE SPRING P/R		
1-5	LJ9166001	1	TONER LED PCB UNIT ASSY ZL2	B512156	
1-6	LJ7403001	2	RUBBER FOOT		
1-7	LG3218001	1	DOCUMENT COVER SENSOR		
1-8	LJ7784001	1	SENSOR CLIP		
1-9	LJ7377001	1	DEVELOP JOINT		add
1-10	LJ7376001	1	JOINT SPRING		add
1-11	UH3044000	1	GEAR, 40/54Y		add
1-12	UL6569000	2	GEAR 17 PLANETARY		add
1-13	UL8977001	1	GEAR 45 ARM F/R		add
1-14	LJ5056001	1	GEAR 20 CENTER F/R		add

MODEL HL-5030/5040/5050/5070N/5050LT US 84U-Z41/Z42/Z43/Z44/Z46-010

2. FRAME R UNIT

REF.NO.	CODE	Q'TY	DESCRIPTION	SYMBOL	REMARK
1	LM2732001	1	MAIN FRAME R UNIT		CHG
1-1	LJ9612001	1	TONER SENSOR PCB UNIT ZL2	B512084	chg
1-2	LJ7403001	2	RUBBER FOOT		
1-3	LM2731001	1	TE FILM		ADD

MODEL HL-5030/5040/5050/5070N/5050LT US 84U-Z41/Z42/Z43/Z44/Z46-011

1. FRAME L / DRIVE UNIT

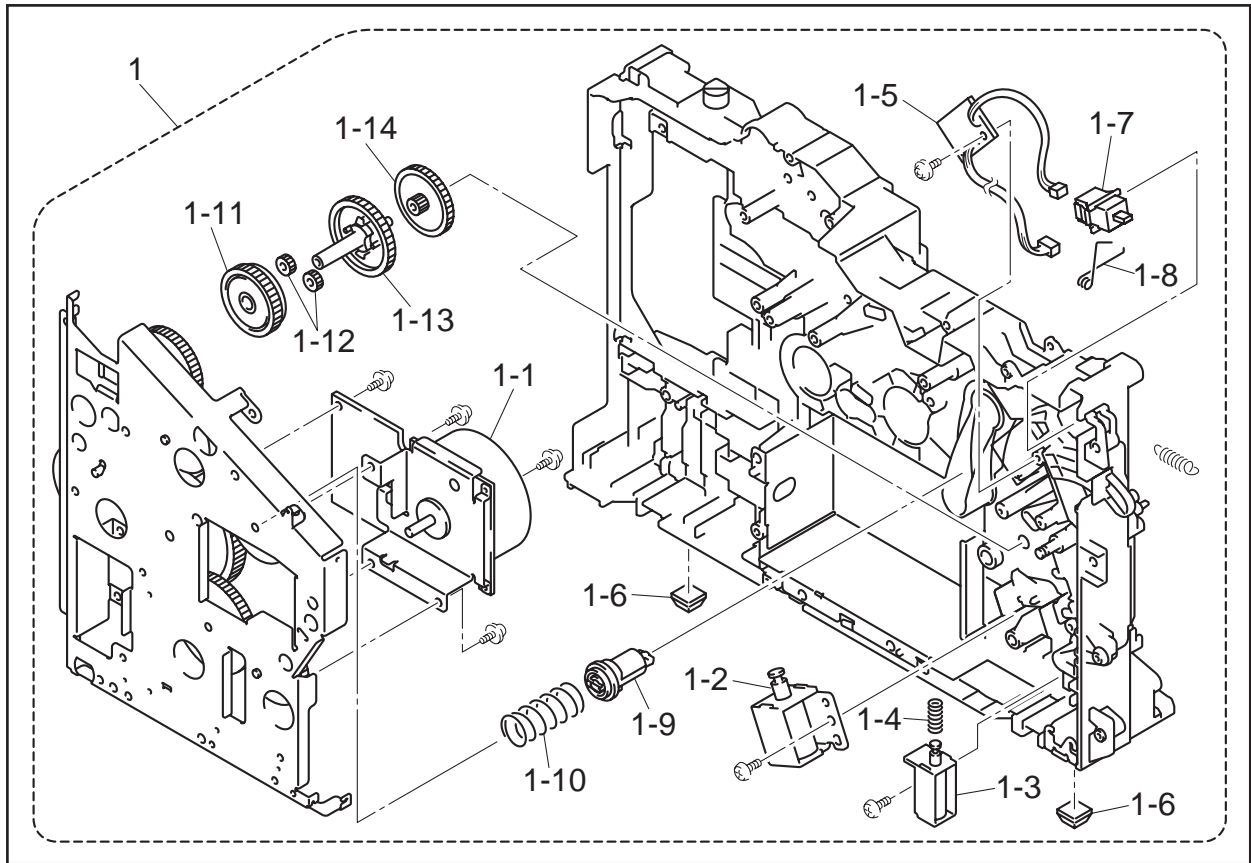

MODEL HL-5030/5040/5050/5070N/5050LT US 84U-Z41/Z42/Z43/Z44/Z46-010

2. FRAME R

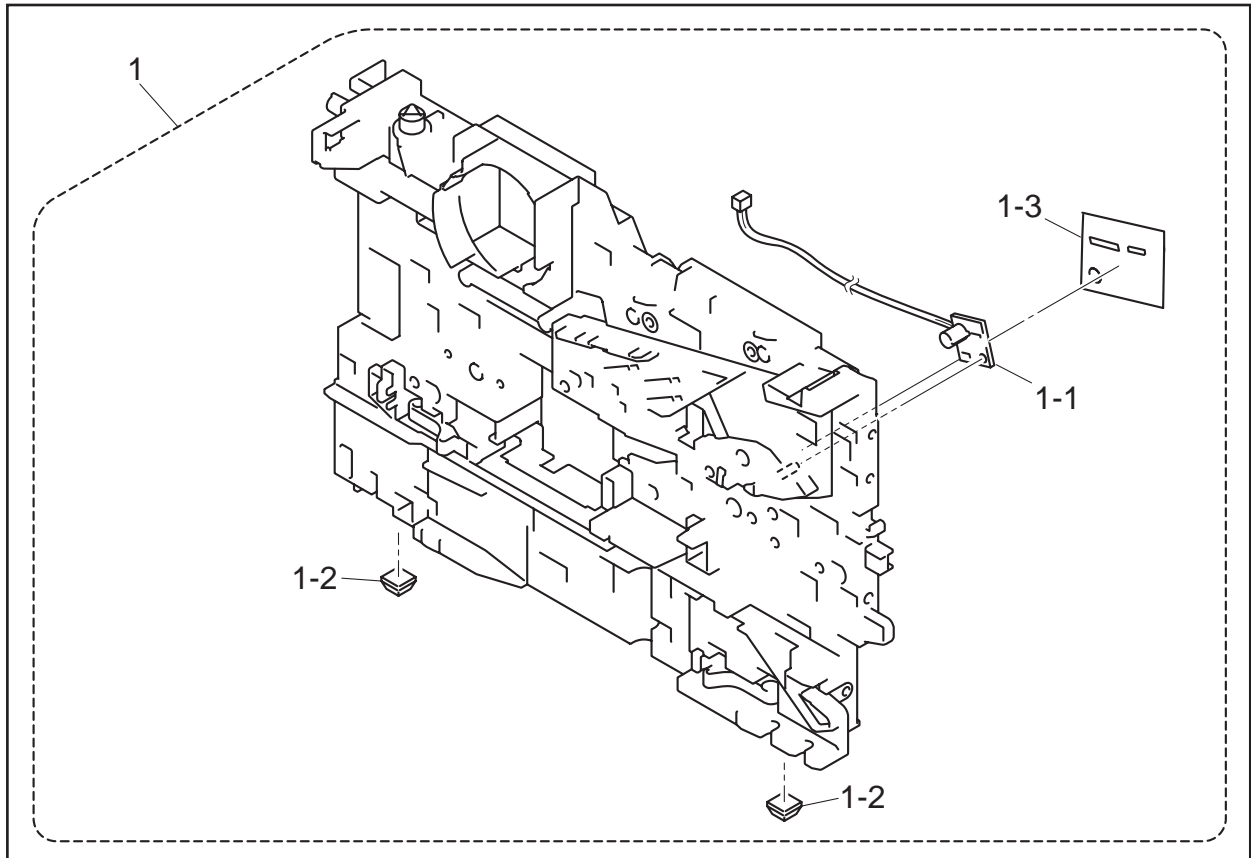

MODEL HL-5030/5040/5050/5070N/5050LT US 84U-Z41/Z42/Z43/Z44/Z46-011

3. FRAME UNIT

REF.NO.	CODE	Q'TY	DESCRIPTION	REMARK
1	LJ7490001	1	GROUND SPRING	
2	LJ7492001	1	FILTER	
3	LJ7496001	1	SPRING, EXTENSION P/R	
4	LJ7501001	1	MIDDLE ROLLER GEAR	
5	LJ7502001	1	IDLE GEAR 22	
6	LJ7504001	1	GROUND WIRE	
7	LJ7505001	1	FAN MOTOR 60 UNIT LV	
8	LJ7508001	1	FAN MOTOR 60 UNIT	
9	LJ7579001	1	MP SOLENOID HOLDER UNIT	
10	LJ7535001	1	SECTOR GEAR PR ASSY	ADD
11	UH2378000	1	SPRING HOOK	ADD

MODEL HL-5030/5040/5050/5070N/5050LT US 84U-Z41/Z42/Z43/Z44/Z46-012

4. LASER UNIT

REF.NO.	CODE	Q'TY	DESCRIPTION	REMARK
1	LM2833001	1	LASER UNIT ZL2 (SP)	chg
2	085310815	6	TAPTITE, BIND B M3X8	

MODEL HL-5030/5040/5050/5070N/5050LT US 84U-Z41/Z42/Z43/Z44/Z46-020

3. FRAME UNIT

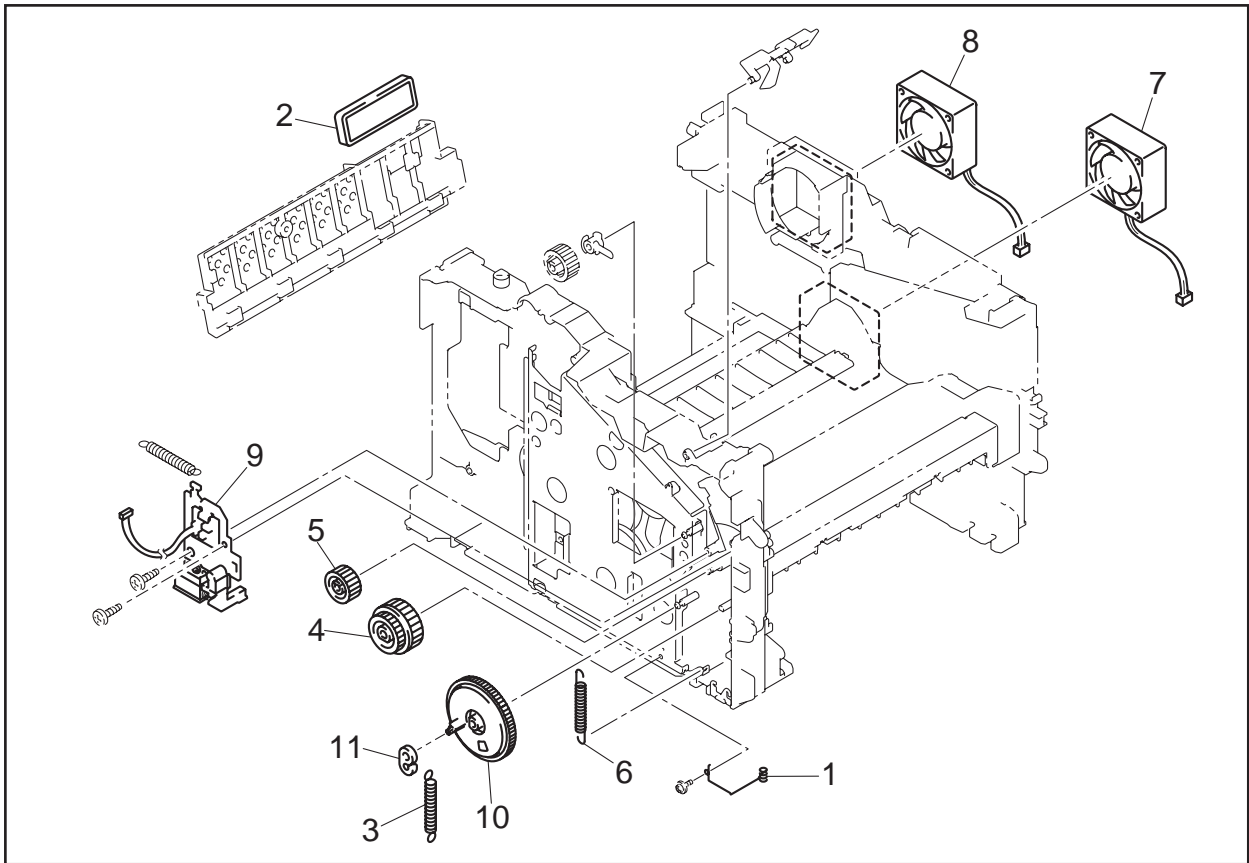

MODEL HL-5030/5040/5050/5070N/5050LT US 84U-Z41/Z42/Z43/Z44/Z46-012

4. LASER UNIT

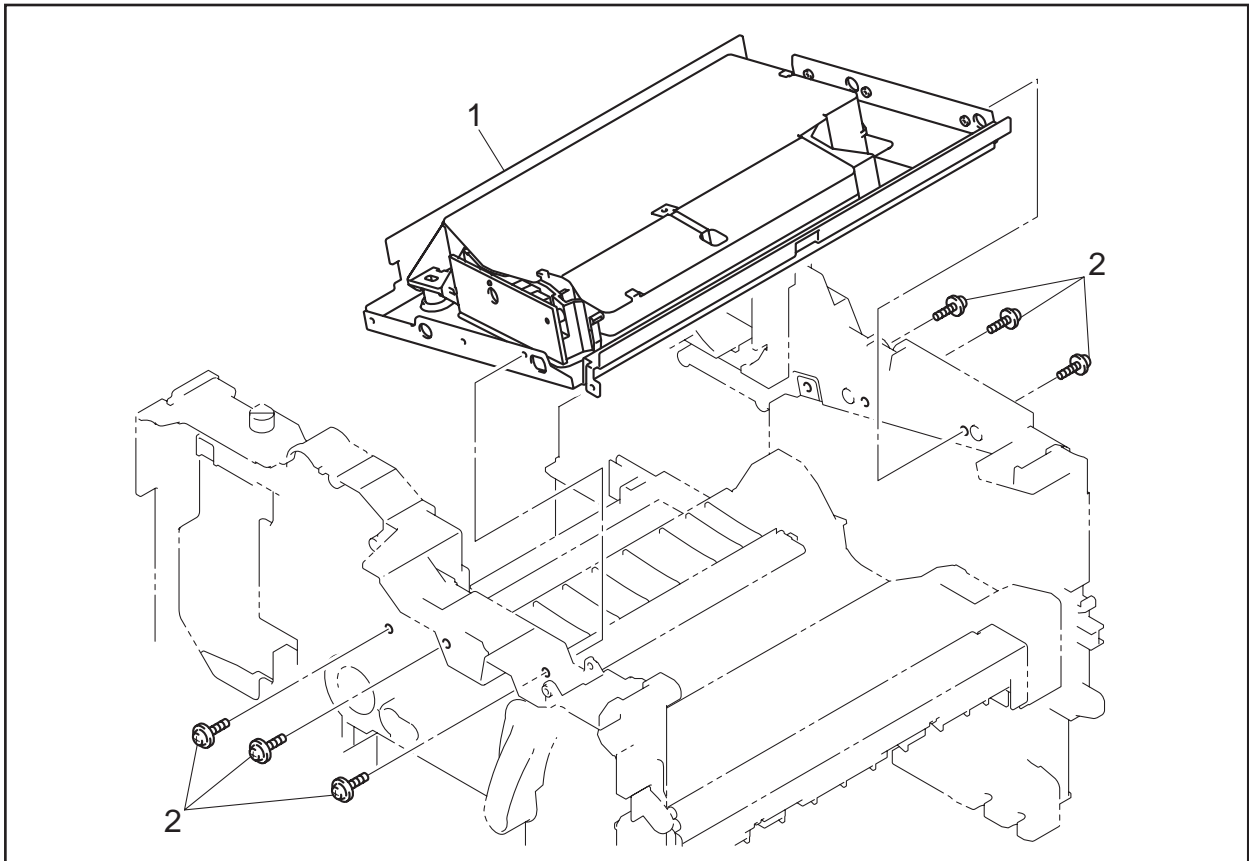

MODEL HL-5030/5040/5050/5070N/5050LT US 84U-Z41/Z42/Z43/Z44/Z46-020

5. PAPER FEEDER

REF.NO.	CODE	Q'TY	DESCRIPTION	SYMBOL	REMARK
1	LJ7322001	1	REGIST FRONT ACTUATOR		
2	LM2590001	1	REGIST FRONT ACTUATOR SPRING		chg
3	LJ7324001	1	REGIST REAR ACTUATOR		
4	LJ7325001	1	REGIST REAR ACTUATOR SPRING		
5	LJ7703001	1	PAPER PICK-UP ROLLER ASSY ZL2		
6	LM2601001	1	PE ACTUATOR ZL2		chg
7	LJ9235001	1	CASSETTE SENSOR PCB ASSY ZL2	B512095	
8	LJ5155001	1	CA ACTUATOR		
9	LJ5211001	1	PE SENSOR COVER		add
10	LM2033001	1	FRONT CHUTE GUIDE ASSY ZL2		add
11	LM2032001	1	FRONT TRAY CHUTE ASSY ZL2		add
12	LJ5020001	1	BUSH L		add
13	LJ5021001	1	BUSH R		add
14	LJ7730001	2	ROLLER COLLAR ZL2		add
15	LM2399001	4	ROLLER GUIDE		DEL
16	LJ7342001	1	FRONT CHUTE		add

MODEL HL-5030/5040/5050/5070N/5050LT US 84U-Z41/Z42/Z43/Z44/Z46-040

6. MP UNIT

REF.NO.	CODE	Q'TY	DESCRIPTION	SYMBOL	REMARK
1	LJ7551001	1	MP UNIT ASSY		
1-1	LJ7555001	1	SEPARATION PLATE ASSY		
1-2	LM2050001	1	PAPER PICK-UP ROLLER ASSY (SP)		chg
1-3	LJ7571001	1	MP-PE ACTUATOR		
1-4	LJ9222001	1	MP-PE SENSOR PCB ASSY ZL2	B512107	
2	LJ7587001	1	MP TRAY ASSY		add
3	LJ7596001	1	MP FRONT COVER ASSY (HL-5050/5070N)		add
3-1	LJ7800001	1	MP COVER RELEASE BUTTON		ADD
4	LJ7589001	1	MP PAPER GUIDE ASSY (HL-5050/5070N)		add
5	LJ7600001	1	DRIVE RELEASE LINK MP (HL-5050/5070N)		add

MODEL HL-5050/5070N/5050LT US 84U-Z43/Z44/Z46-041

5. PAPER FEEDER

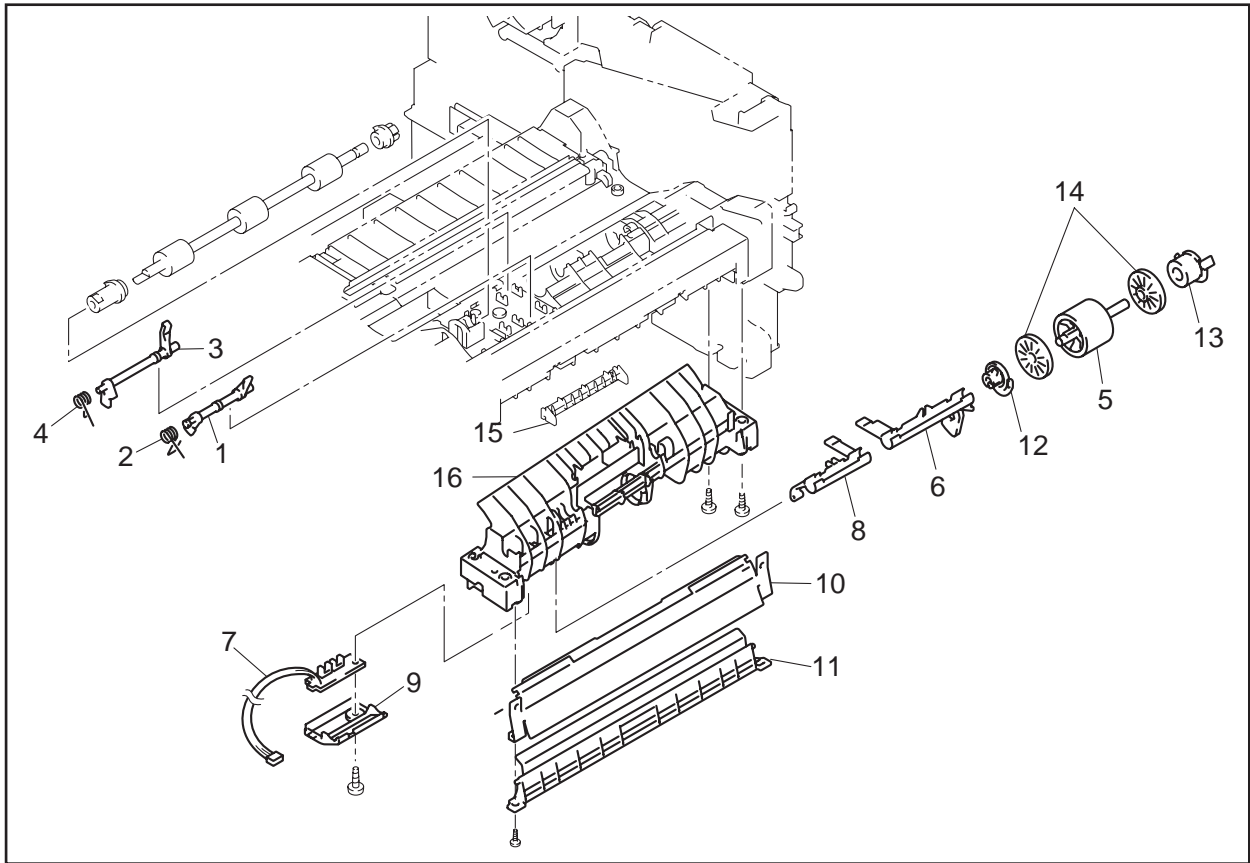

MODEL HL-5030/5040/5050/5070N/5050LT US 84U-Z41/Z42/Z43/Z44/Z46-040

6. MP UNIT

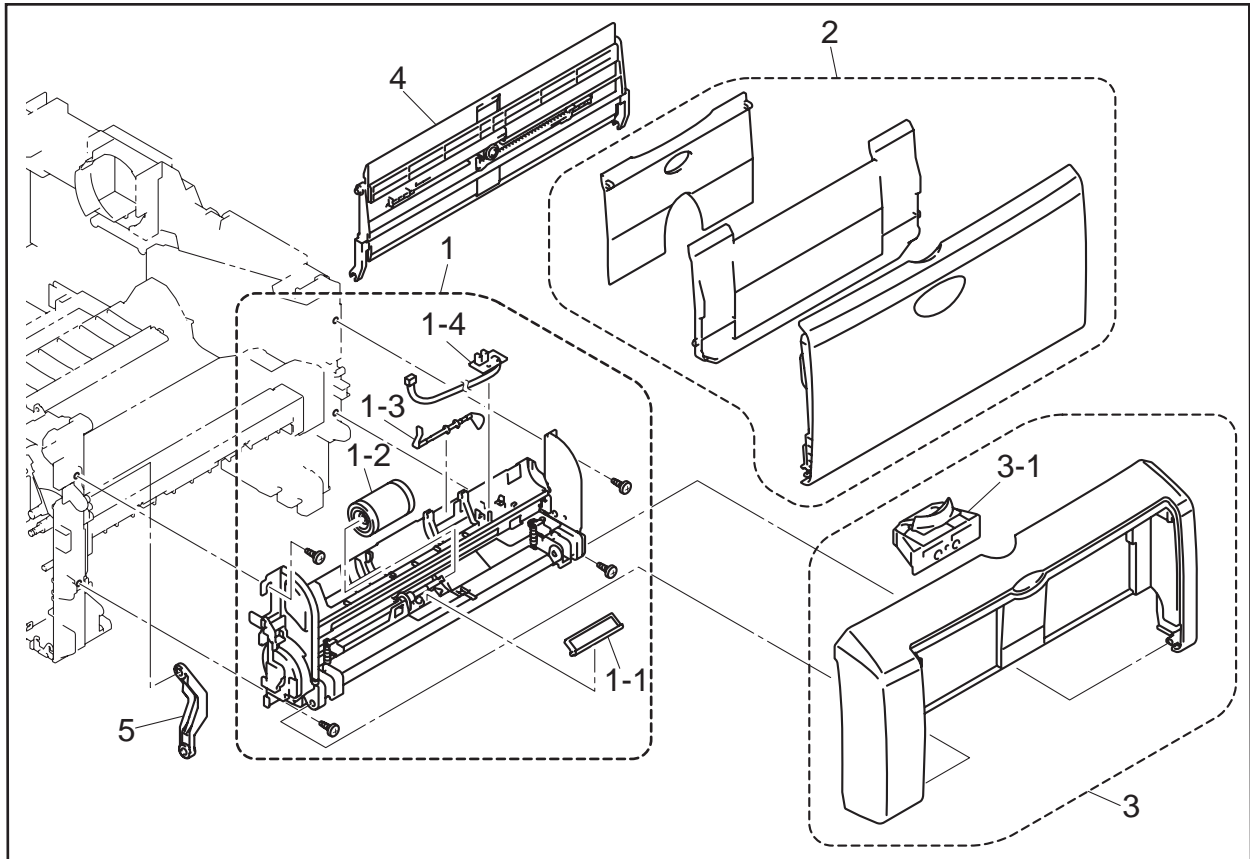

MODEL HL-5050/5070N/5050LT US 84U-Z43/Z44/Z46-041

7. PAPER TRAY

REF.NO.	CODE	Q'TY	DESCRIPTION	REMARK
1	LJ7607001	1	PAPER TRAY ASSY ZL2 BRO 2	
1-1	LJ7307001	1	PAD HOLDER ZL2	
1-2	LJ5923001	1	SEPARATION PAD SPRING 350	
1-3	LJ7315001	1	PAPER TRAY FRONT COVER	
1-4	LJ7616001	1	PAPER TRAY COVER	
1-5	LJ7608001	1	PAPER TRAY FRONT COVER LT	
2	LM2467001	4	SHEET, CUSTOMIZE UK ZL2 (UK only)	DEL

MODEL HL-5030/5040/5050/5070N/5050LT US 84U-Z41/Z42/Z43/Z44/Z46-045

7. PAPER CASSETTE

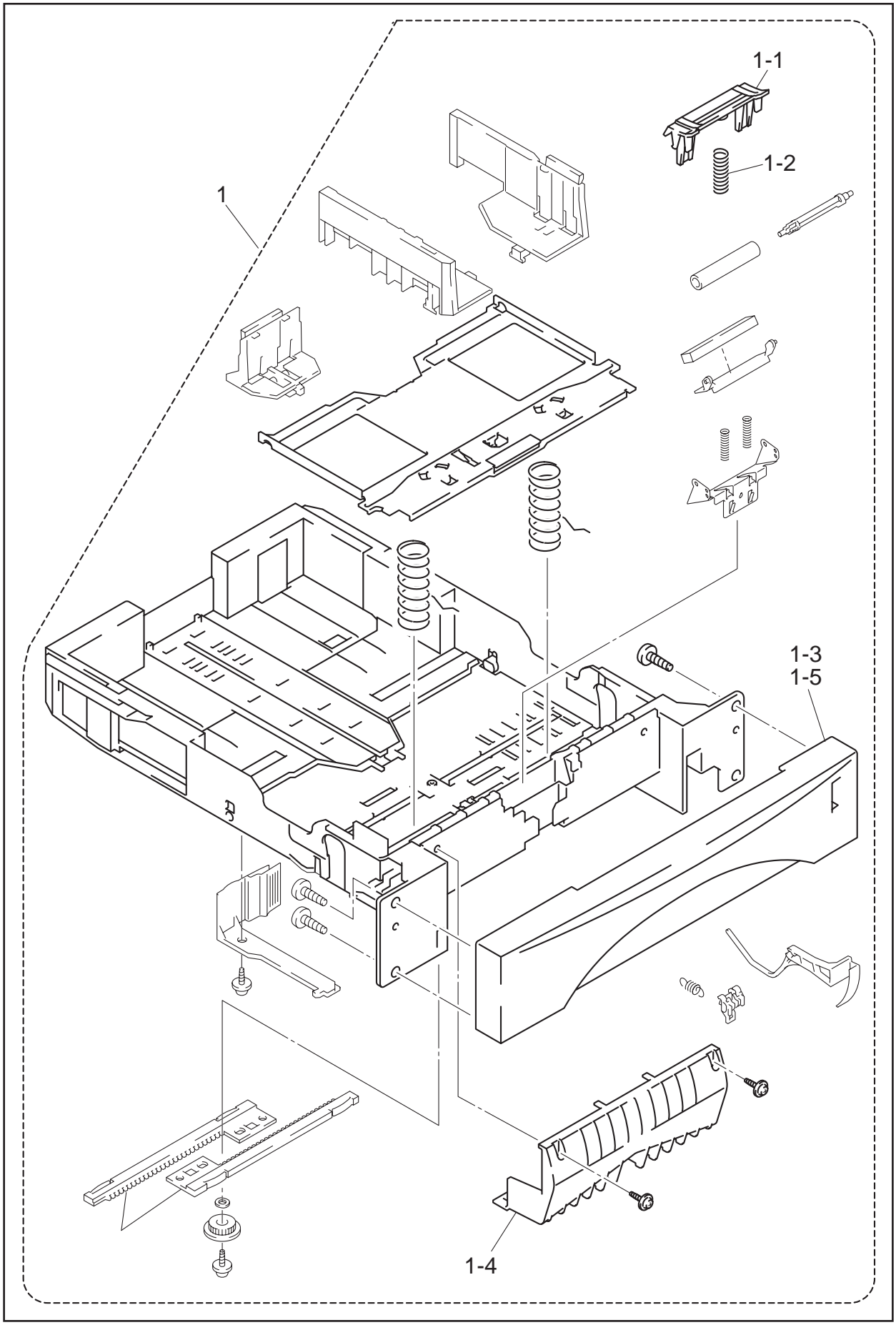

MODEL HL-5030/5040/5050/5070N/5050LT US 84U-Z41/Z42/Z43/Z44/Z46-045

8. FIXING UNIT

REF.NO.	CODE	Q'TY	DESCRIPTION	SYMBOL	REMARK
1	LM2216001	1	FIXING UNIT, 230V(SP)		chg
1	LM2215001	1	FIXING UNIT, 115V(SP)		chg
1-1	LJ7413001	1	HEAT ROLLER 25		
1-2	LJ7539001	1	HALOGEN LAMP, 230V		
1-2	LJ7417001	1	HALOGEN LAMP, 115V		
1-3	LJ7877001	4	SEPARATE CLAW ASSY C		
1-4	LJ7419001	1	THERMISTOR ASSY		
1-5	087311215	1	TAPTITE, CUP B M3X12		
1-6	LJ7428001	3	CLEANER PINCH ROLLER ASSY S		
1-7	LJ7432001	1	CLEANER PINCH ROLLER ASSY L		
1-8	LJ7436001	1	PRESSURE ROLLER 25		
1-9	LJ9174001	1	THERMISTOR RELAY PCB ASSY ZL2		
1-10	LJ5289001	1	PAPER EJECT ACTUATOR		
1-11	LJ5066001	1	EJECT ACTUATOR SPRING		
1-12	LJ9176001	1	EJECT SENSOR PCB ASSY ZL2		
1-13	LJ7416001	1	HR GEAR 34		add
1-14	LJ7414001	2	HR BEARING 25		add
1-15	LM2254001	2	SCREW, PAN (S/P WASHER) M26x8		add
1-16	LM2255001	2	WASHER, PLAIN 26		add
1-17	LM2047001	2	IDLE GEAR 13		add
1-18	LJ4118001	1	EJECT ROLLER ASSY		ADD
2	085411216	1	TAPTITE, BIND B M4X12		chg
3	LJ4740001	1	SHOULDER SCREW		chg
4	LM2102001	1	FU LAMP ASSEMBLY JIG ASSY		add

MODEL HL-5030/5040/5050/5070N/5050LT US 84U-Z41/Z42/Z43/Z44/Z46-050

8. FIXING UNIT

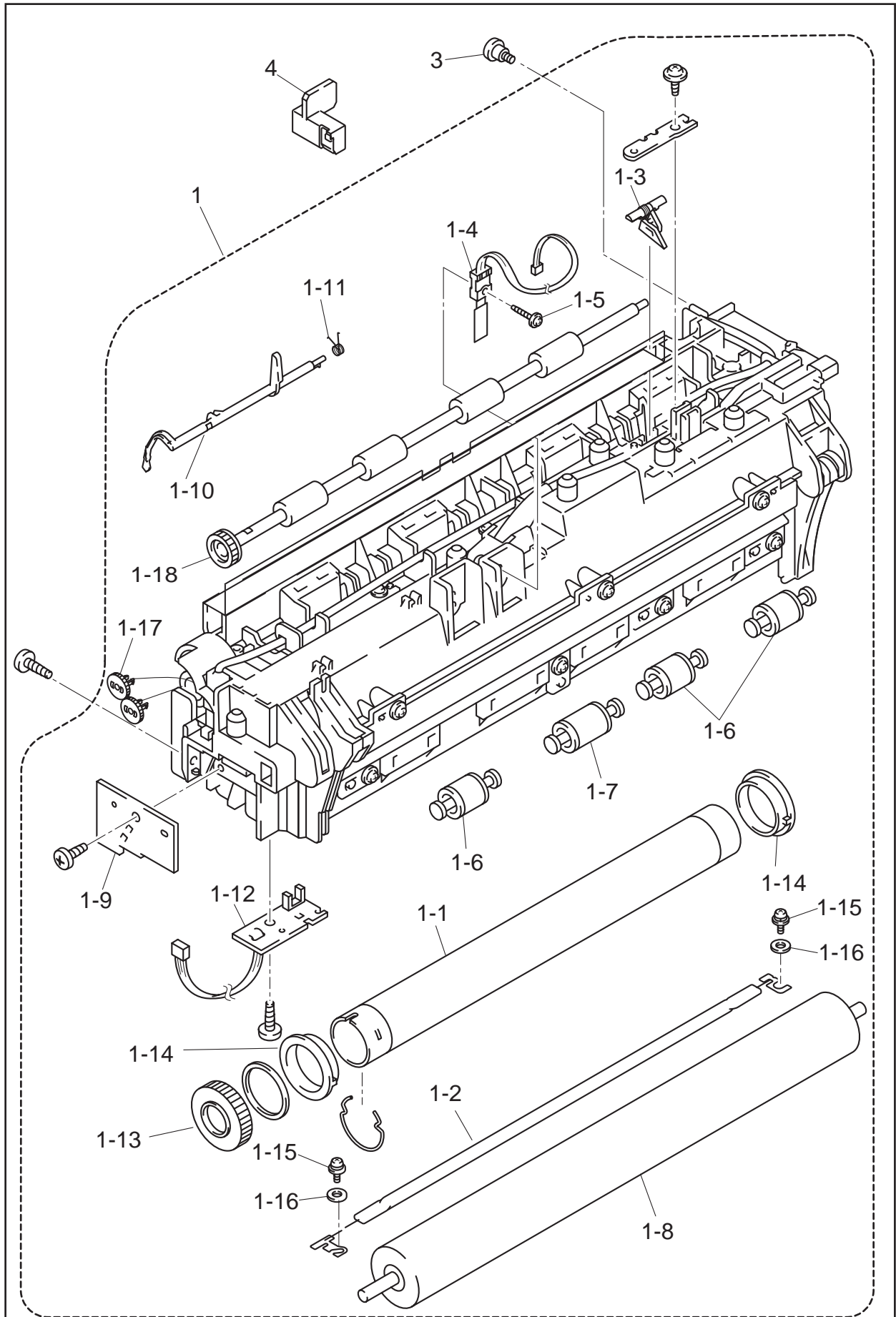

MODEL HL-5030/5040/5050/5070N/5050LT US 84U-Z41/Z42/Z43/Z44/Z46-050

9. COVERS

REF.NO.	CODE	Q'TY	DESCRIPTION	REMARK
1	LM2103001	1	TOP COVER ASSY	chg
1-1	LJ7926001	2	CORRUGATION PINCH ROLLER W	del
1-2	LJ7925001	2	PINCH ROLLER HOLDER W	del
1-1	LJ7911001	2	CORRUGATION PINCH ROLLER R	add
1-2	LJ7912001	2	CORRUGATION PINCH ROLLER L	add
1-3	UL9123001	4	PINCH ROLLER HOLDER	add
2	LJ7451001	1	SW KEY A	
3	LJ7452001	1	SW KEY B	
4	087310815	3	TAPTITE, CUP B M3X8	chg
5	LJ7453001	1	SIDE COVER R	
6	LM2448001	1	SIDE COVER L	chg
7	LM2554001	1	FRONT COVER ASSY (HL-5030/5040)	chg
7-1	LJ7463001	1	FRONT COVER RELEASE BUTTON	ADD
8	LJ7465001	1	REAR COVER R (HL-5030/5040)	
9	LJ7617001	1	REAR COVER R MP (HL-5050/5070N)	
10	LJ7466001	1	REAR COVER L (HL-5030/5040)	
11	LJ7618001	1	REAR COVER L MP (HL-5050/5070N)	
12	LJ7610001	1	REAR COVER MP (HL-5050/5070N)	
13	LJ7613001	1	REAR COVER MP TRAY (HL-5050/5070N)	
14	LJ7467001	1	REAR COVER C	
15	085411216	1	TAPTITE, BIND B M4X12	
16	LJ7469001	1	OUTER CHUTE (HL-5030/5040)	
17	LJ7470001	1	OUTER CHUTE TRAY (HL-5030/5040)	
18	LJ7699001	1	OUTER CHUTE DX ASSY (HL-5050/5070N)	
19	LJ7471001	1	ACCESS COVER	
20	LJ7895001	1	SUPPORT FLAP	
21	LJ7896001	1	SUPPORT FLAP S	
22	LJ9180001	1	PANEL PCB ASSY	add
23	LJ0908001	1	LASER CAUTION LABEL B	add
24	LJ7350001	1	BROTHER EMBLEM	add
25	LJ7468001	1	LINK (HL-5030/5040)	add

MODEL HL-5030/5040/5050/5070N/5050LT US 84U-Z41/Z42/Z43/Z44/Z46-060

9. COVERS

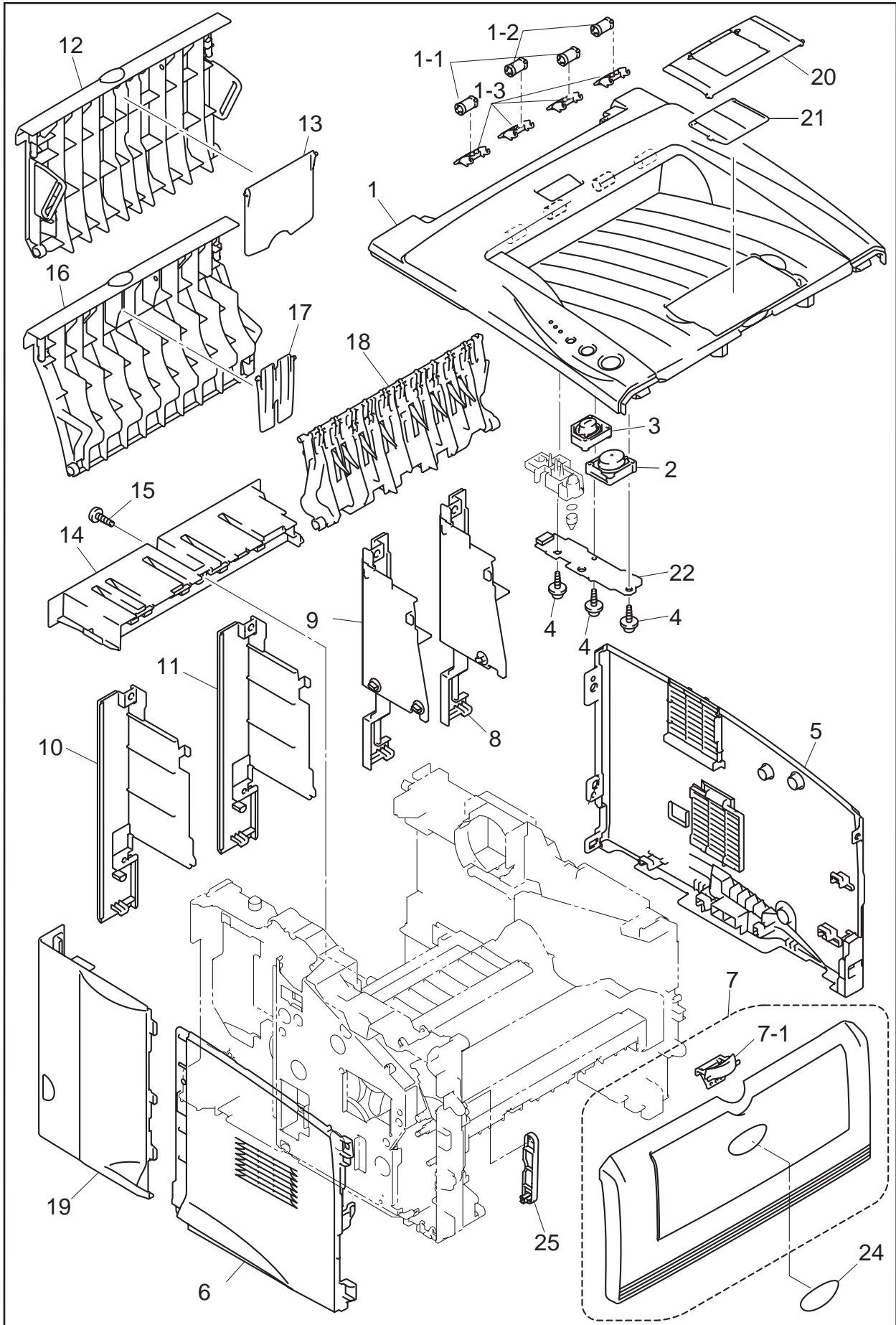

MODEL HL-5030/5040/5050/5070N/5050LT US 84U-Z41/Z42/Z43/Z44/Z46-060

10. MAIN PCB

REF.NO.	CODE	Q'TY	DESCRIPTION	SYMBOL	REMARK
1	LJ9314001	1	MAIN PCB ASSY 5030	B512159-320	
1	LJ9205001	1	MAIN PCB ASSY 5040	B512159-300	
1	LJ9220001	1	MAIN PCB ASSY 5050	B512159-310	
1	LJ9241001	1	MAIN PCB ASSY 5070N	B512155-300	

MODEL HL-5030/5040/5050/5070N/5050LT US 84U-Z41/Z42/Z43/Z44/Z46-101

10. MAIN PCB

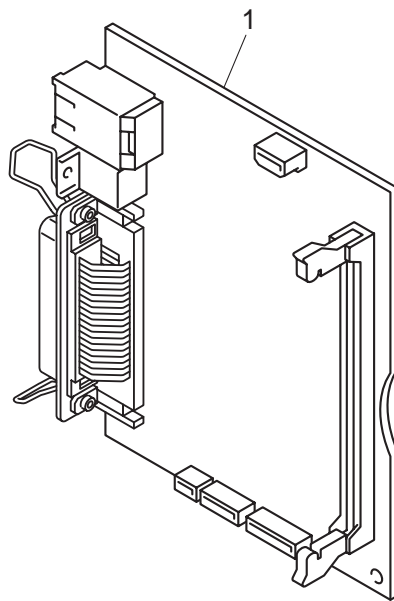
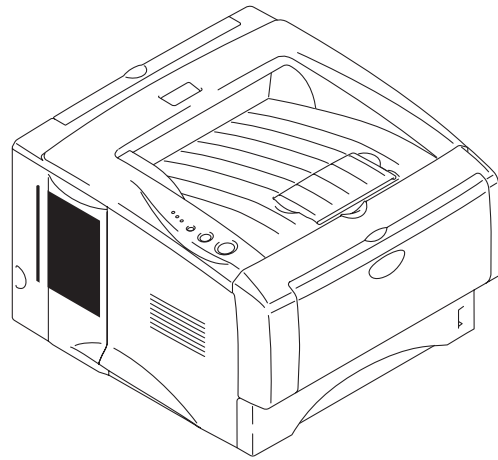

MODEL HL-5030/5040/5050/5070N/5050LT US 84U-Z41/Z42/Z43/Z44/Z46-101

11. ENGINE PCB

REF.NO.	CODE	Q'TY	DESCRIPTION	SYMBOL	REMARK
1	LJ9188001	1	ZL2 ENGINE PCB ASSY 1 (HL-5030)	B512153	
1	LJ9221001	1	ZL2 ENGINE PCB ASSY 2 (HL-5050/70N)	B512153	
1	LG4404001	1	ZL2 ENGINE PCB ASSY 4 (HL-5040)	B512153	

MODEL HL-5030/5040/5050/5070N/5050LT US 84U-Z41/Z42/Z43/Z44/Z46-151

12. LOW-VOLTAGE POWER SUPPLY PCB

REF.NO.	CODE	Q'TY	DESCRIPTION	SYMBOL	REMARK
1	LJ9620001	1	PS PCB UNIT 230V (SP)		CHG
1	LJ9621001	1	PS PCB UNIT 115V (SP)		CHG
2	085411216	1	TAPTITE, BIND B M4X12		
3	LM2048001	1	SCREW, PAN (S/P WASHER) M3.5X6		chg

MODEL HL-5030/5040/5050/5070N/5050LT US 84U-Z41/Z42/Z43/Z44/Z46-200

11. ENGINE PCB

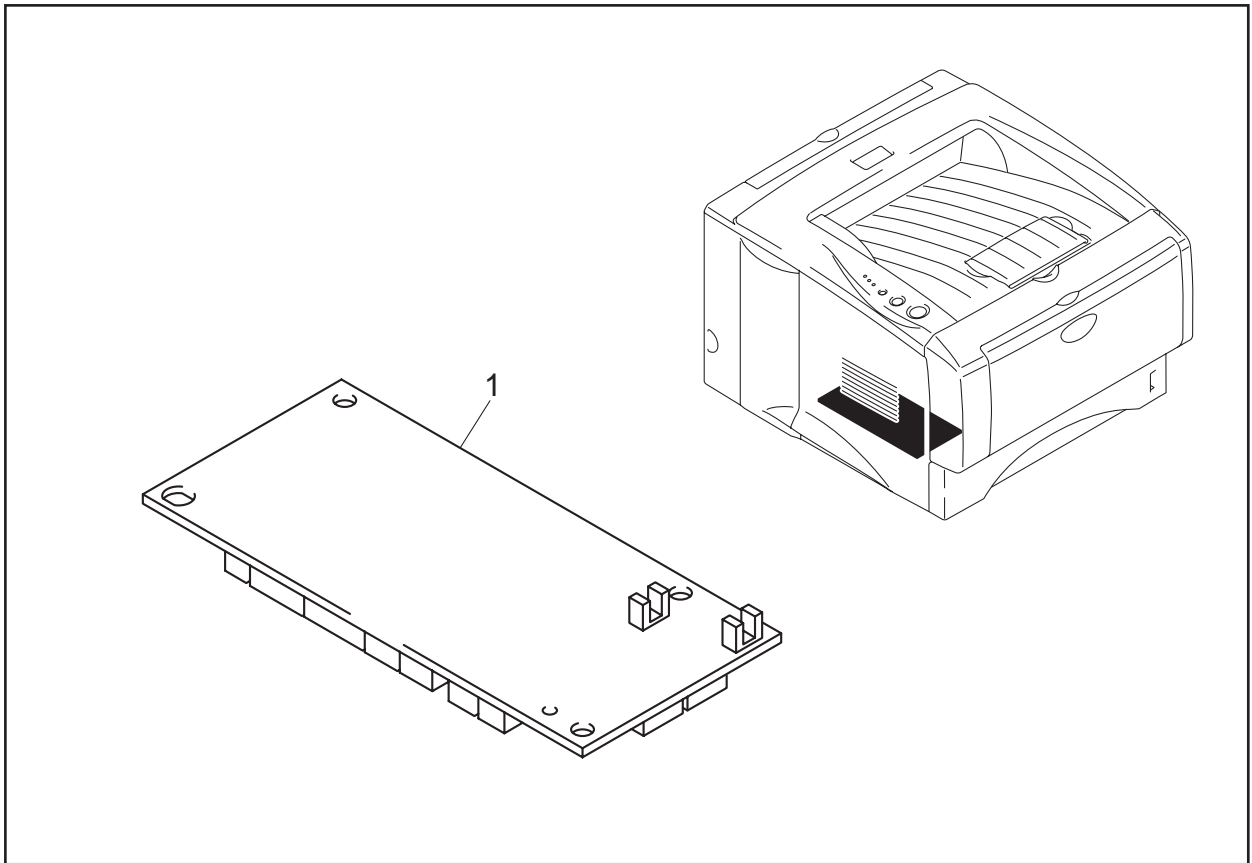

MODEL HL-5030/5040/5050/5070N/5050LT US 84U-Z41/Z42/Z43/Z44/Z46-151

12. LOW-VOLTAGE POWER SUPPLY PCB

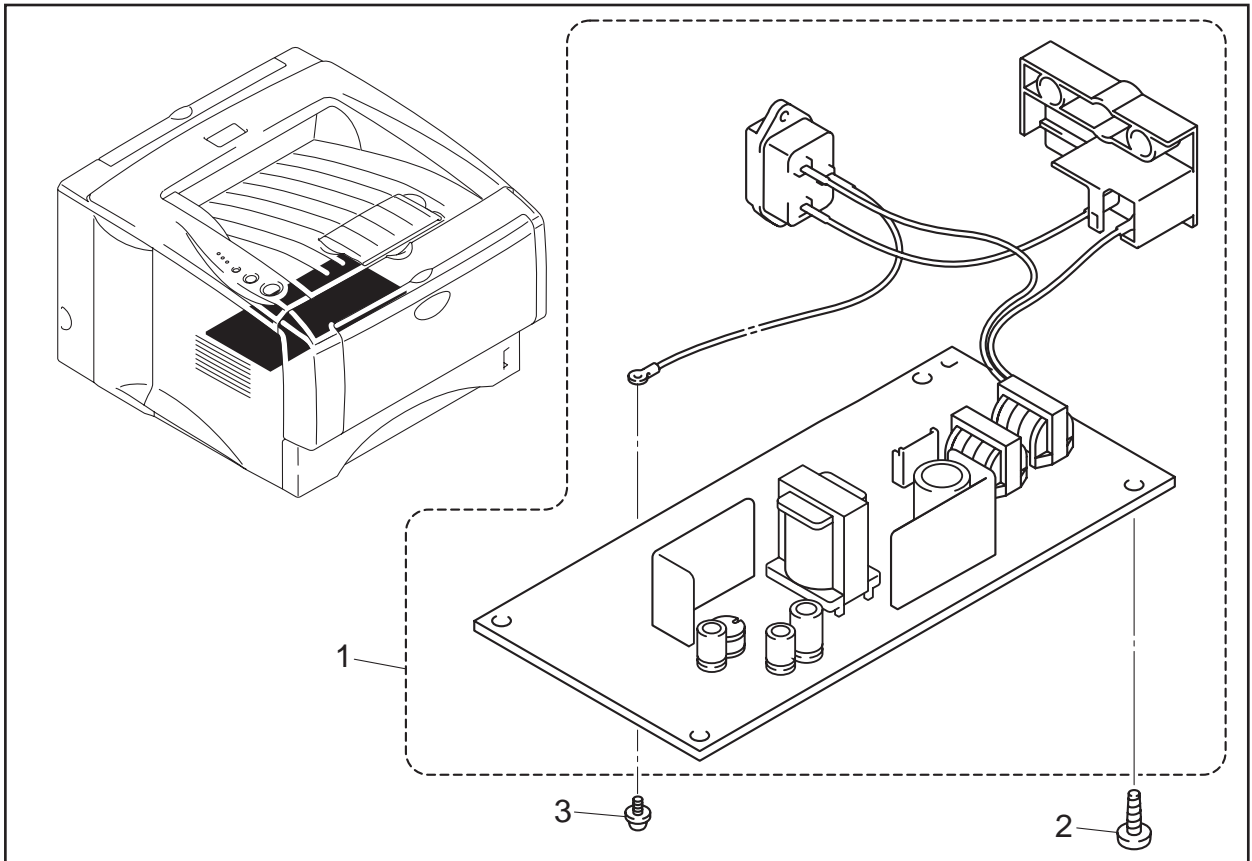

MODEL HL-5030/5040/5050/5070N/5050LT US 84U-Z41/Z42/Z43/Z44/Z46-200

13. HIGH-VOLTAGE POWER SUPPLY PCB

REF.NO.	CODE	Q'TY	DESCRIPTION	SYMBOL	REMARK
1	LJ9200001	1	HIGH-VOLTAGE PS PCB ASSY ZL2		
2	085411216	1	TAPTITE, BIND B M4X12		

MODEL HL-5030/5040/5050/5070N/5050LT US 84U-Z41/Z42/Z43/Z44/Z46-220

14. ACCESSORIES

REF.NO.	CODE	Q'TY	DESCRIPTION	REMARK
4	LJ7880001	4	CD ASSY 5030/5040	DEL
1	LJ7770001	1	CD ASSY 5030/5040/5050/5070N	

MODEL HL-5030/5040/5050/5070N/5050LT US 84U-Z41/Z42/Z43/Z44/Z46-920

13. HIGH-VOLTAGE POWER SUPPLY PCB

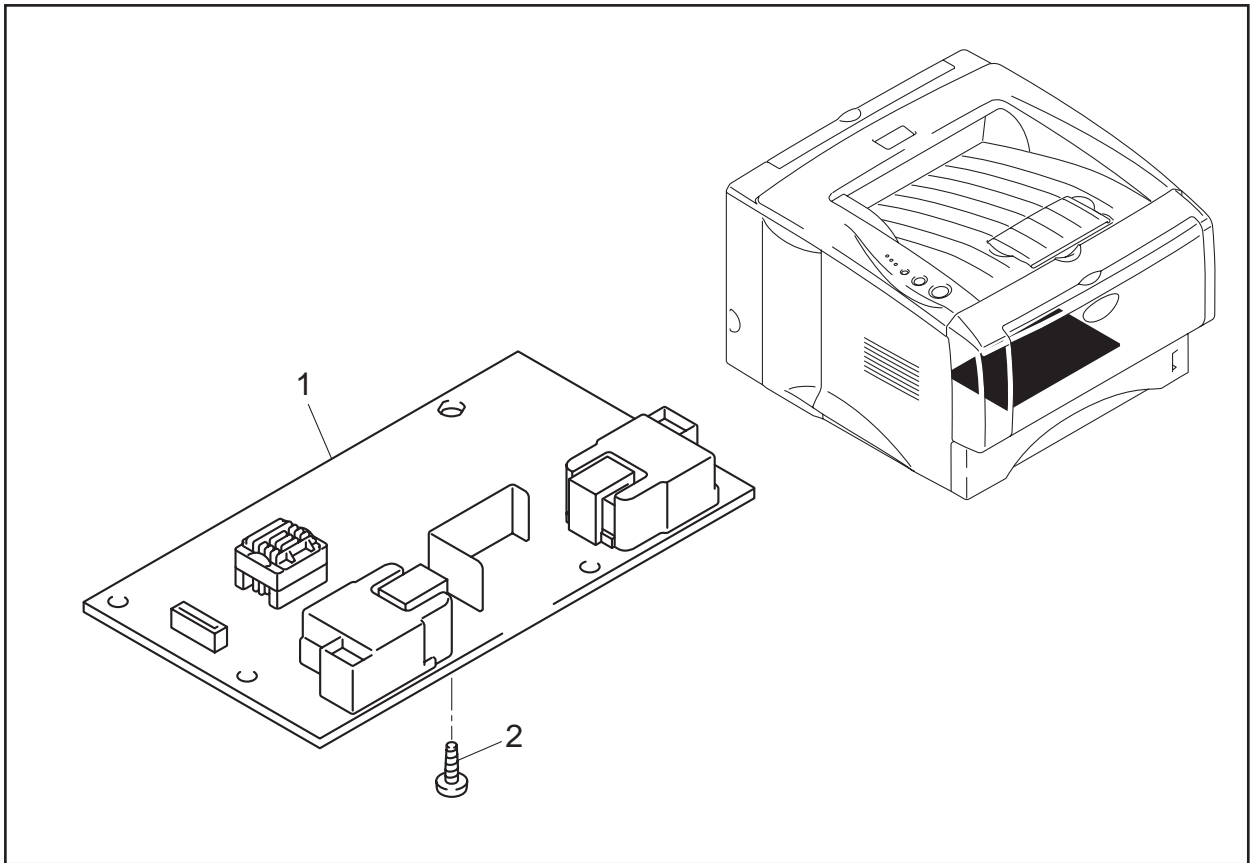

MODEL HL-5030/5040/5050/5070N/5050LT US 84U-Z41/Z42/Z43/Z44/Z46-220

14. ACCESSORIES

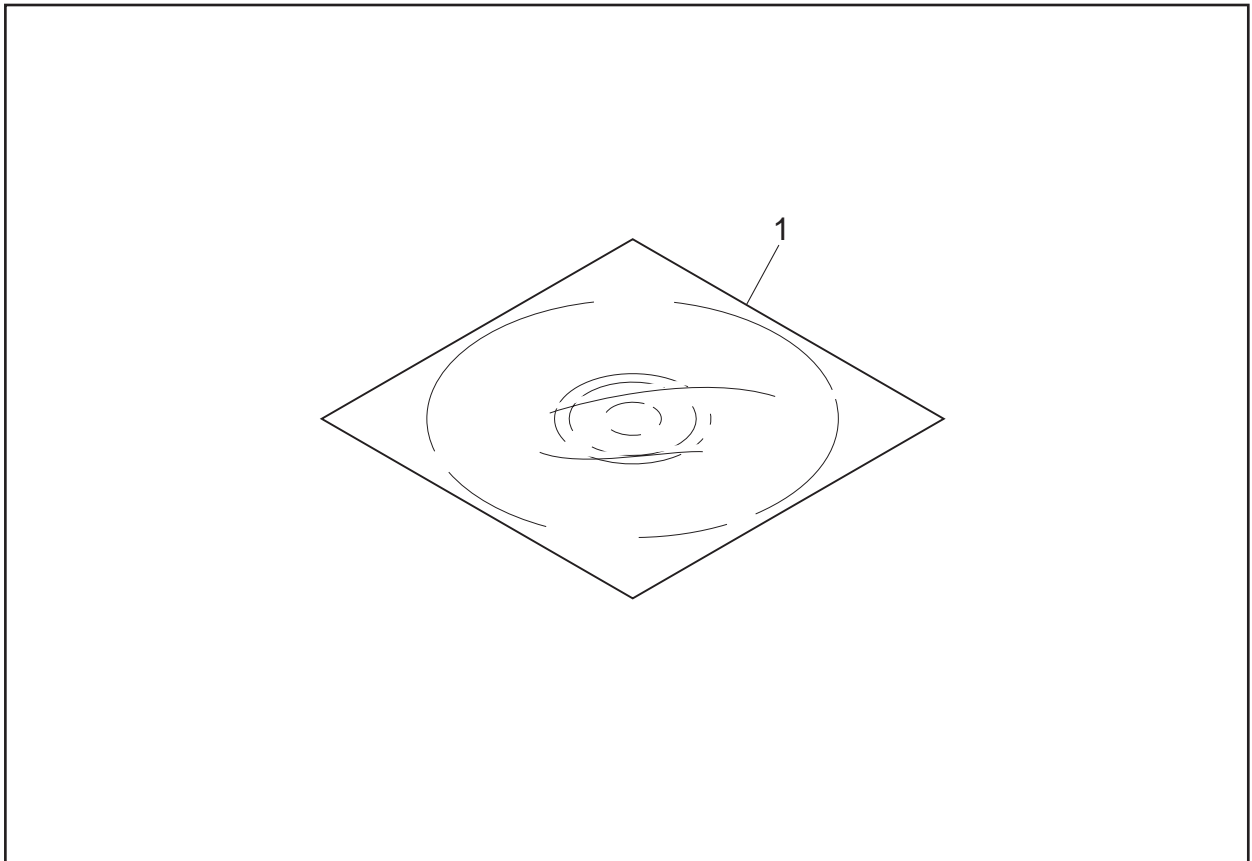

MODEL HL-5030/5040/5050/5070N/5050LT US 84U-Z41/Z42/Z43/Z44/Z46-920

15. PACKING MATERIALS

REF.NO.	CODE	Q'TY	DESCRIPTION	REMARK
1	LL0654001	1	CARTON, HL-5030 EUR	
1	LL0655001	1	CARTON, HL-5040 US	
1	LL0665001	1	CARTON, HL-5050 US	
1	LL0667001	1	CARTON, HL-5070N US	
1	LL0656001	1	CARTON, HL-5040 EUR	
1	LL0666001	1	CARTON, HL-5050 EUR	
1	LL0668001	1	CARTON, HL-5070N EUR	
2	LJ7357001	1	POLYSTYRENE PAD ASSY ZL2	
2	LJ7545001	1	POLYSTYRENE PAD ASSY ZL2 MP	
3	LJ5584001	1	BAG, 700X800H	
4	LL0695001	1	CARTON, OUTER HL-5050LT US	

MODEL HL-5030/5040/5050/5070N/5050LT US 84U-Z41/Z42/Z43/Z44/Z46-930

16. PERIODICAL MAINTENANCE PARTS

REF.NO.	CODE	Q'TY	DESCRIPTION	REMARK
1	LJ7920001	1	PAPER FEEDING KIT	
1-1	LJ7703001	1	PAPER PICK-UP ROLLER ASSY ZL2*1	
1-2	LJ7307001	1	PAD HOLDER ZL2 *2	
2	LM2953001	1	ROLLER 6 GUIDE/ ROLLER (SP)	ADD
2-1		1	ROLLER 6 GUIDE	
2-2		1	FIRST FEED ROLLER ASSY ZL2	
			*1 Refer to "5. PAPER FEEDER"	
			*2 Refer to "7. PAPER CASSETTE"	

MODEL HL-5030/5040/5050/5070N/5050LT US 84U-Z41/Z42/Z43/Z44/Z46-940

15. PACKING MATERIALS

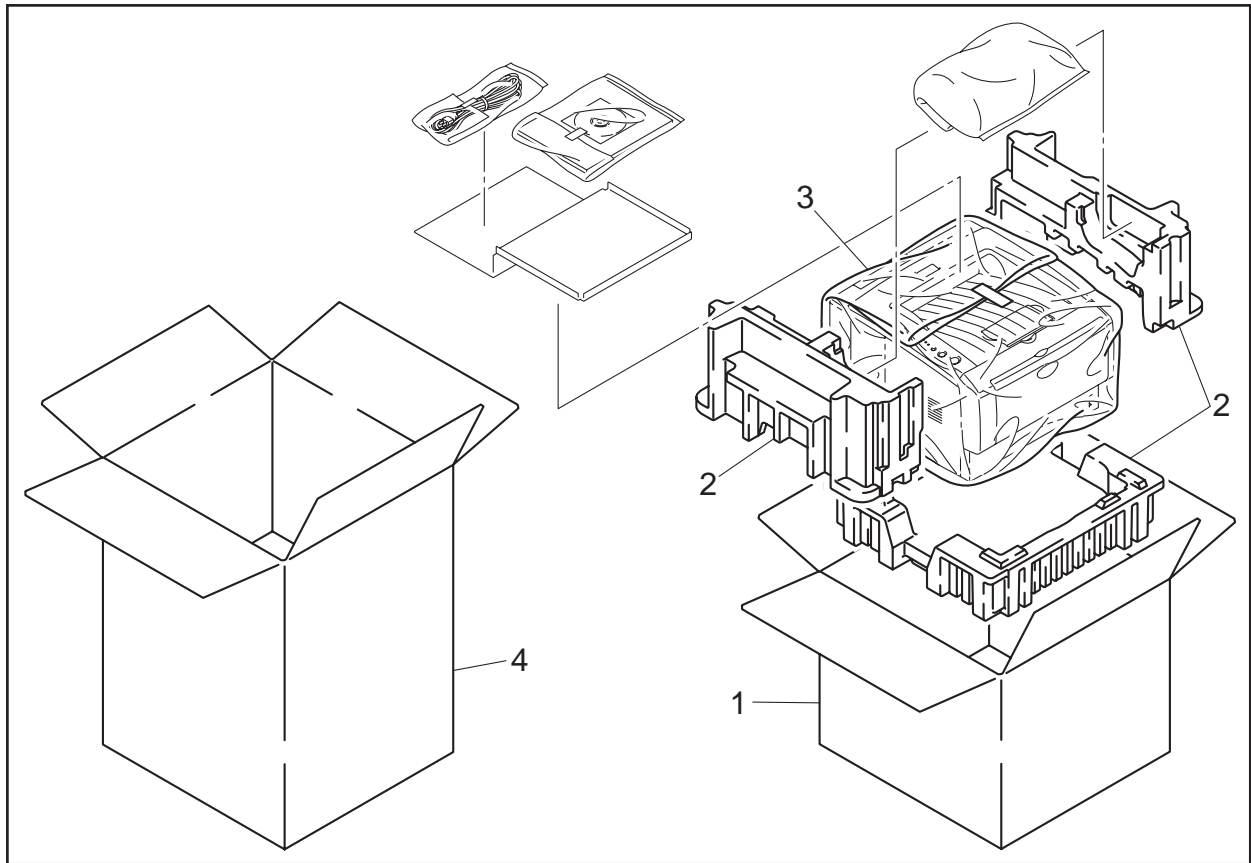

MODEL HL-5030/5040/5050/5070N/5050LT US 84U-Z41/Z42/Z43/Z44/Z46-930

16. PERIODICAL MAINTENANCE PARTS

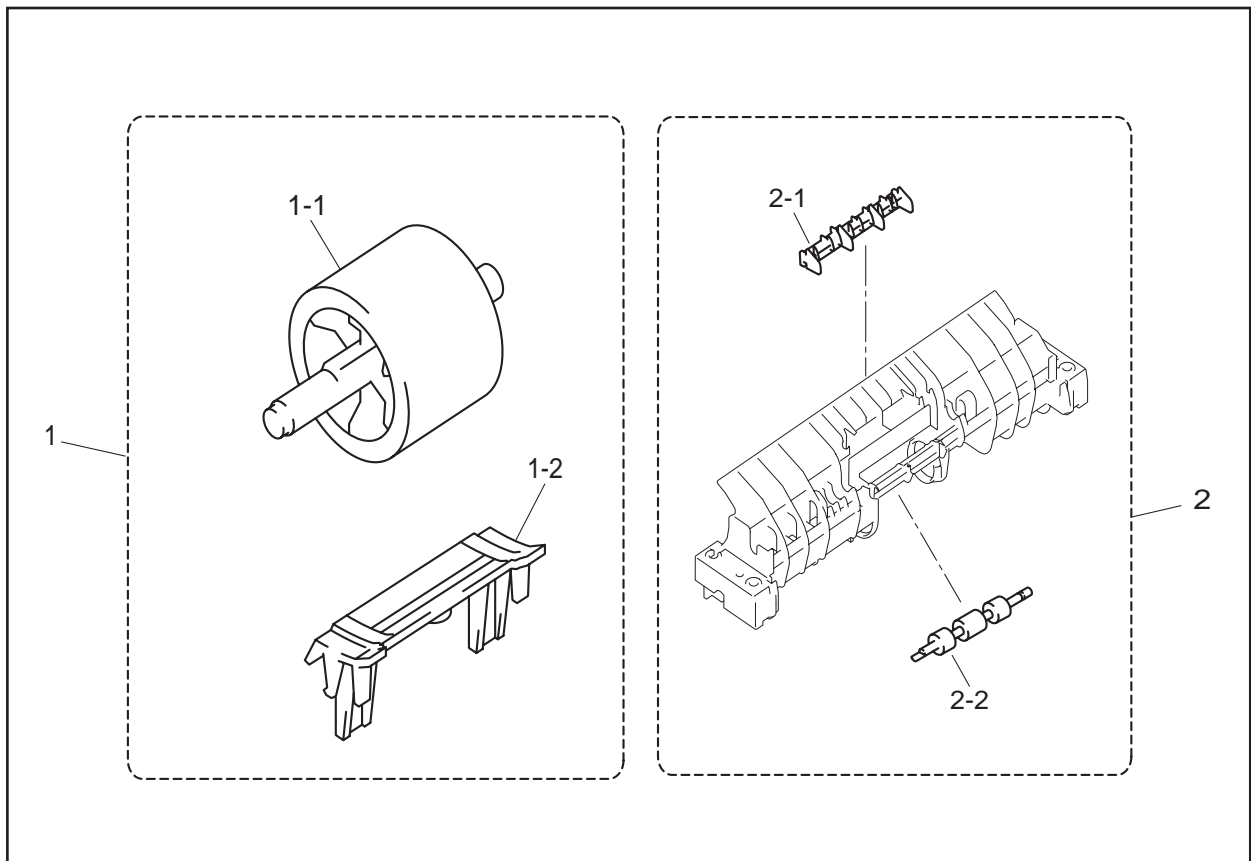







MODEL HL-5030/5040/5050/5070N/5050LT US 84U-Z41/Z42/Z43/Z44/Z46-940

17. AC CORDS

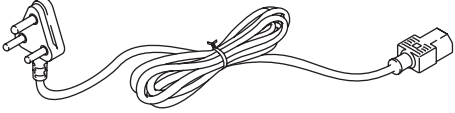
REF.NO.	CODE	Q'TY	DESCRIPTION	REMARK
1	LJ9103001	1	AC CORD ASSY LF, VDE	
2	LJ9921001	1	AC CORD ASSY LF, BS/PSB	chg
3	LJ9254001	1	AC CORD ASSY LF, SEV	
4	LJ9256001	1	AC CORD ASSY LF, DEMKO	
5	LJ9295001	1	AC CORD ASSY LF, SOUTH AFRICA	
6	LJ9271001	1	AC CORD ASSY LF, UL/CSA 10A	
7	LJ9666001	1	AC CORD LF, SAA	chg
8	LM9288001	1	AC CORD ASSY LF, ISRAEL	ADD

MODEL HL-5030/5040/5050/5070N/5050LT US 84U-Z41/Z42/Z43/Z44/Z46-230

17. AC CORDS

1		5	
2		6	
3		7	
4		8	

MODEL HL-5030/5040/5050/5070N/5050LT US 84U-Z41/Z42/Z43/Z44/Z46-230