



**FACSIMILE EQUIPMENT
SERVICE MANUAL**

**MODEL: MFC7300C/MFC7400C/
MFC830/MFC840**

1. EQUIPMENT OUTLINE

1.1 External Appearance and Weight

The figure below shows the equipment appearance and approximate dimensions.

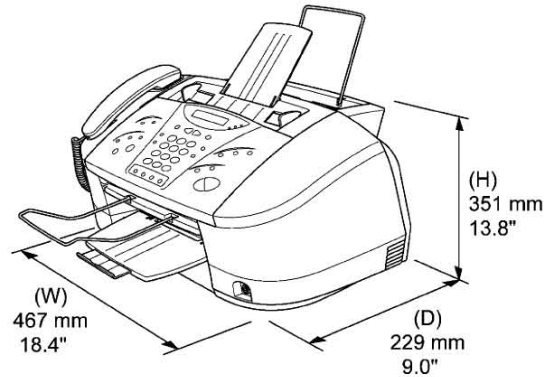

Weight:	Machine proper	Approx. 8 kg
	In package	Approx. 12 kg

1.2 Components

The equipment consists of the following major components:

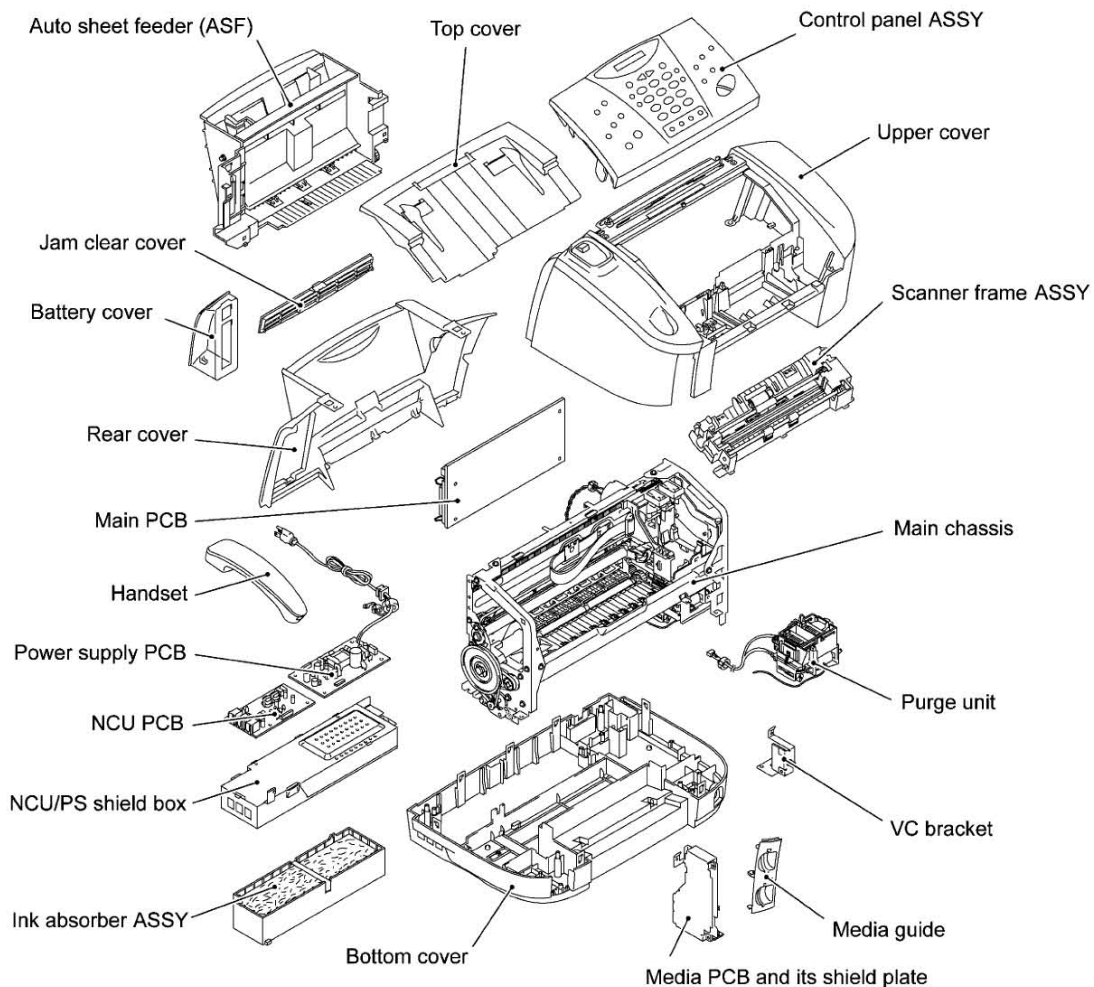

2. SPECIFICATIONS

(1/6)

Model Name	MFC7300C (Fax/Copy/Print/Scan/Video Capture)	MFC7400C (Fax/Copy/Print/Scan/PhotoCapture Center/Video Capture/PC-Fax)
GENERAL		
Print Engine	Ink Jet (BY4)	Ink Jet (BY4)
Modem Speed (bps)	14,400 (Fax)	14,400 (Fax)
Transmission Speed (sec.)	6 (Brother#1, MMR)	5 (Brother#1, JBIG)
ITU-T Group	G3	G3
Coding System	MH/MR/MMR/JPEG	MH/MR/MMR/JBIG/JPEG
Input/Output Width	5.8" to 8.5"/3.5" to 8.5"	5.8" to 8.5"/3.5" to 8.5"
Input/Output Length	5" to 14"/5" to 14"	5" to 14"/5" to 14"
ADF (pages)	Up to 20	Up to 20
LCD Size	16 chars x 1 line	16 chars x 1 line
LCD Backlight	No	No
On-Screen Programming	Yes	Yes
Back up Clock	Yes (1 hour)	Yes (1 hour)
Memory Capacity (physical)	4 MB (RAM)	4 MB (RAM)
Optional Memory	No	No
Dimensions w/ Carton (W x D x H)	22.3" x 15.0" x 17.6"	22.3" x 15.0" x 17.6"
Dimensions w/o Carton (W x D x H)	18.4" x 9.0" x 13.8"	18.4" x 9.0" x 13.8"
Weight w/o Carton (W x D x H)	18 lb	18 lb
Weight w/ Carton (W x D x H) + 2	27 lb	27 lb
Color	Gray 1495	Gray 1495
Standby Mode	No	No
PC-Fax Protocol Compliance	N/A	Class 2
Simultaneous Operation	Yes (Print/Fax, Print/Copy, Print/Scan)	Yes (Print/Fax, Print/Copy, Print/Scan)
Energy Star Compliant	Yes	Yes
Operating Environment Temperature	5 to 35°C	5 to 35°C
Humidity	60% ±25%	60% ±25%
Power Source	120 VAC, 50/60Hz	120 VAC, 50/60Hz
Power Consumption (Standby/Peak)	Under 10W/45W	Under 10W/45W
On/Off Switch	No	No
TELEPHONE		
Automatic Redial	Yes	Yes
Handset	Yes	Yes
One-Touch Dial	8 (4 x 2)	8 (4 x 2)
Speed Dial	100	100
Figures of One-Touch & Speed Dial	20 digits	20 digits
Registerable Number of Characters	15 chars	15 chars
Telephone Index	Yes (Normal)	Yes (Normal)
Speaker Phone	No	No

Model Name	MFC830 (Fax/Copy/Print/Scan/Video Capture)	MFC840 (Fax/Copy/Print/Scan/PhotoCapture Centre/ Video Capture)
GENERAL		
Print Engine	Ink Jet (BY4)	Ink Jet (BY4)
Modem Speed (bps)	14,400 (Fax)	14,400 (Fax)
Transmission Speed (sec.)	6 (Brother#1, MMR)	5 (Brother#1, JBIG)
ITU-T Group	G3	G3
Coding Method	MH/MR/MMR/JPEG	MH/MR/MMR/JBIG/JPEG
Input/Output Width	148 x 216 mm/90 x 216 mm	148 x 216 mm/90 x 216 mm
Input/Output Length	127 x 356 mm/127 x 356 mm	127 x 356 mm/127 x 356 mm
ADF (pages)	Up to 20	Up to 20
LCD Size	16 chars x 1 line	16 chars x 1 line
LCD Backlight	No	No
On-Screen Programming	Yes	Yes
Backup Clock	Yes (1 hour)	Yes (1 hour)
Memory Capacity (physical)	4 MB (RAM)	4 MB (RAM)
Optional Memory	No	No
Dimensions w/ Carton (W x D x H)	566 x 381 x 447 mm	566 x 381 x 447 mm
Dimensions w/o Carton (W x D x H)	467 x 229 x 351 mm	467 x 229 x 351 mm
Weight w/o Carton (W x D x H)	8 kg	8 kg
Weight w/ Carton (W x D x H)	12 kg	12 kg
Color	Gray 1495	Gray 1495
Standby Mode	No	No
PC-Fax Protocol Compliance	N/A	N/A
Simultaneous Operation	Yes (Print/Fax, Print/Copy, Print/Scan)	Yes (Print/Fax, Print/Copy, Print/Scan)
Energy Star Compliant	Yes	Yes
Operating Environment Temperature Humidity	5 to 35°C 60% ±25%	5 to 35°C 60% ±25%
Power Source	240 VAC, 50/60Hz	240 VAC, 50/60Hz
Power Consumption (Standby/Peak)	Under 10W/45W	Under 10W/45W
On/Off Switch	No	No
TELEPHONE		
Automatic Redial	Yes	Yes
Handset	No	Yes
One-Touch Dial	8 (4 x 2)	8 (4 x 2)
Speed Dial	50	100
Figures of One-Touch & Speed Dial	20 digits	20 digits
Registerable Number of Characters	15 chars	15 chars
Telephone Index	Yes (Normal)	Yes (Normal)
Speaker Phone	No	No
Chain Dialing	Yes	Yes
Caller ID	N/A	N/A

Model Name	MFC7300C (Fax/Copy/Print/Scan/Video Capture)	MFC7400C (Fax/Copy/Print/Scan/PhotoCapture Center/Video Capture/PC-Fax)
Chain Dialing	Yes	Yes
Caller ID	Yes	Yes
Call Waiting Caller ID	Yes	Yes
Distinctive Ringing	Yes	Yes
Hold/Mute Key	Yes	Yes
Power Failure Dialing	No	No
Speaker Volume	Yes (3 levels + OFF)	Yes (3 levels + OFF)
Ringer Volume	Yes (3 levels + OFF)	Yes (3 levels + OFF)
Receiver Volume	Yes	Yes
PBX Feature	No	No
Transfer Method	No	No
FAX		
Internet FAX	N/A	N/A
Data Modem	N/A	N/A
Easy Receive/Fax Detect	Yes	Yes
Fax/Tel Switch	Yes	Yes
Super Fine	Yes	Yes
300dpi Transmission	No	No
Gray Scale	256	256
Contrast	Yes (Auto/S.Light/S.Dark)	Yes (Auto/S.Light/S.Dark)
Smoothing	No	No
Call Reservation Over Auto TX	Yes	Yes
Password Check	No	No
Enhanced Remote Activate	Yes	Yes
Multi Resolution Transmission	Yes	Yes
Multi Transmission	No	No
Next-Fax Reservation	Yes (Dual Access)	Yes (Dual Access)
Delayed Timer	Yes (50 timers/50 jobs)	Yes (50 timers/50 jobs)
Polling	Yes (Std/Seq)	Yes (Std/Seq)
Quick-Scan key	(Memory TX w/o key)	(Memory TX w/o key)
Scan Speed (A4: Standard)	Approx. 3 sec./page (A4: standard)	Approx. 3 sec./page (A4: standard)
Memory Transmission (Brother#1 Chart)	Yes (180: MMR)	Yes (220: JBIG)
Memory Transmission (ITU-T Chart)	Yes (150: MMR)	Yes (200: JBIG)
Broadcasting	Yes (158 locations)	Yes (158 locations)
Batch Transmission	Yes	Yes
Auto Reduction	Yes	Yes
Out-of-Paper Reception (Brother #1 Chart)	180 (MMR)	220 (JBIG)
Out-of-Paper Reception (ITU-T Chart)	150 (MMR)	200 (JBIG)
Dual Access	Yes	Yes

Model Name	MFC830 (Fax/Copy/Print/Scan/Video Capture)	MFC840 (Fax/Copy/Print/Scan/PhotoCapture Centre/ Video Capture)
Call Waiting Caller ID	N/A	N/A
Distinctive Ringing	Yes	Yes
Hold/Mute Key	N/A	N/A
Power Failure Dialing	No	No
Speaker Volume	Yes (3 levels + OFF)	Yes (3 levels + OFF)
Ringer Volume	Yes (3 levels + OFF)	Yes (3 levels + OFF)
Receiver Volume	No	No
PBX Feature	Yes	Yes
Transfer Method	Flash	Flash
FAX		
Internet FAX	N/A	N/A
Data Modem	N/A	N/A
Easy Receive/Fax Detect	Yes	Yes
Fax/Tel Switch	Yes	Yes
Super Fine	Yes	Yes
300dpi Transmission	No	No
Gray Scale	256	256
Contrast	Yes (Auto/S.Light/S.Dark)	Yes (Auto/S.Light/S.Dark)
Smoothing	No	No
Call Reservation Over Auto TX	Yes	Yes
Password Check	No	No
Enhanced Remote Activate	Yes	Yes
Multi Resolution Transmission	Yes	Yes
Multi Transmission	No	No
Next-Fax Reservation	Yes (Dual Access)	Yes (Dual Access)
Delayed Timer	Yes (50 timers/50 jobs)	Yes (50 timers/50 jobs)
Polling	Yes (Std/Seq/Secure/Timer) - B&W Only	Yes (Std/Seq/Secure/Timer) - B&W Only
Quick-Scan key	(Memory TX w/o key)	(Memory TX w/o key)
Scan Speed (A4: Standard)	Approx. 3 sec./page (A4: standard)	Approx. 3 sec./page (A4: standard)
Memory Transmission (Brother #1 Chart)	Yes (120: MMR)	Yes (220: JBIG)
Memory Transmission (ITU-T Chart)	Yes (100: MMR)	Yes (200: JBIG)
Broadcasting	Yes (108 locations)	Yes (158 locations)
Batch Transmission	Yes	Yes
Auto Reduction	Yes	Yes
Out-of-Paper Reception (Brother #1 Chart)	Yes (120: MMR)	220 (JBIG)
Out-of-Paper Reception (ITU-T Chart)	Yes (100: MMR)	200 (JBIG)
Dual Access	Yes	Yes
ECM (Error Correction Mode)	Yes	Yes

Model Name	MFC7300C (Fax/Copy/Print/Scan/Video Capture)	MFC7400C (Fax/Copy/Print/Scan/PhotoCapture Center/Video Capture/PC-Fax)
ECM (Error Correction Mode)	Yes	Yes
ITU SUB Addressing	No	No
Group Dial	Yes (6)	Yes (6)
Error Re-Transmission	No	No
Station ID	1 (20 digits/20 chars)	1 (20 digits/20 chars)
Off-Hook Alarm	No	No
Remote Maintenance	Yes	Yes
Call Reservation Over Manual TX	Yes	Yes
RX Mode Indication	LCD	LCD
Resolution Indication	LED (Green)	LED (Green)
Memory Security	No	No
Color FAX (Document Send/Receive)	Yes/Yes	Yes/Yes
Color FAX (Memory Send/Receive)	No/Yes	No/Yes
Manual Broadcasting	Yes	Yes
LCD Language	English	English
Call Manage	No	No
E-MAIL FAX (Service)	N/A	N/A
LIST/REPORT		
Activity Report/Journal Report	Yes (up to 50)	Yes (up to 50)
Transmission Verification Report	Yes	Yes
Coverpage	Yes (Super)	Yes (Super)
Help List	Yes (Function Menu)	Yes (Function Menu)
Callback Message	Yes	Yes
Caller ID List	Yes	Yes
Auto Dial List	Yes	Yes
Tel Index List	Yes	Yes
Order Form	Yes	Yes
INTERFACE		
External TAD Interface	Yes	Yes
Missing Link/PC Interface	No	No
Host Interface (Serial)	No	No
Host Interface (IEEE1284)	Yes	Yes
Host Interface (USB)	Yes	Yes
LAN Interface	No	No
Acceptable Media Card Slot	N/A	SmartMedia/Compact Flash
Analog Video Port	Yes	Yes
PRINTER		
Color/Mono	Color/Mono	Color/Mono
Engine Type	Piezo Ink Jet (BY4)	Piezo Ink Jet (BY4)

Model Name	MFC830 (Fax/Copy/Print/Scan/Video Capture)	MFC840 (Fax/Copy/Print/Scan/PhotoCapture Centre/ Video Capture)
ITU SUB Addressing	No	No
Group Dial	Yes (6)	Yes (6)
Error Re-Transmission	No	No
Station ID	1 (20 digits/20 chars)	1 (20 digits/20 chars)
Off-Hook Alarm	No	Yes
Remote Maintenance	Yes	Yes
Call Reservation Over Manual TX	Yes	Yes
RX Mode Indication	LCD	LCD
Resolution Indication	LED (Green)	LED (Green)
TX Lock	Yes	Yes
Color FAX (Document Send/Receive)	Yes/Yes	Yes/Yes
Color FAX (Memory Send/Receive)	No/Yes	No/Yes
Manual Broadcasting	Yes	Yes
LCD Language	English	English
Call Manage	No	No
E-MAIL FAX(Service)	N/A	N/A
LIST/REPORT		
Activity Report/Journal Report	Yes (up to 50)	Yes (up to 50)
Transmission Verification Report	Yes	Yes
Coverpage	Yes (Super)	Yes (Super)
Help List	Yes (Combination keys)	Yes (Combination keys)
Callback Message	Yes	Yes
Caller ID List	No	No
Auto Dial List (All Dial List)	Yes	Yes
Tel Index List	Yes	Yes
Order Form	Yes	Yes
INTERFACE		
External TAD Interface	Yes	Yes
Missing Link/PC Interface	No	No
Host Interface (Serial)	No	No
Host Interface (IEEE1284)	Yes	Yes
Host Interface (USB)	Yes	Yes
LAN Interface	No	No
Acceptable Media Card Slot	N/A	SmartMedia/Compact Flash
Analog Video Port	Yes	Yes
PRINTER		
Color/Mono	Color/Mono	Color/Mono
Engine Type	Piezo Ink Jet (BY4)	Piezo Ink Jet (BY4)
Resolution (dpi)	1200 x 1200	1200 x 1200

Model Name	MFC7300C (Fax/Copy/Print/Scan/Video Capture)	MFC7400C (Fax/Copy/Print/Scan/PhotoCapture Center/Video Capture/PC-Fax)
Resolution (dpi)	1200 x 1200	1200 x 1200
Speed (ppm)	12/10 (Mono/Color)	12/10 (Mono/Color)
Paper Capacity (sheets)	100	100
Additional Paper Capacity (sheets)	No	No
Output Paper Capacity (sheets)	50	50
Standard Print Language	Windows GDI	Windows GDI
Emulation	No	No
Resident Fonts	No	No
Fonts Disk Based	Yes	Yes
Paper Handling Size	LTR, LGL, A4, B5, A5, EXE	LTR, LGL, A4, B5, A5, EXE
Manual Feed Slot	N/A	N/A
Other Paper Type	OHP, Envelopes, Organizer	OHP, Envelopes, Organizer
Sheet Weight (Paper Cassette)	64 to 105 g/m ² (17 to 28 lb)	64 to 105 g/m ² (17 to 28 lb)
(Manual Slot)	N/A	N/A
Printer Driver	Windows 95/98 SE/2000 Professional/ NT4.0/ME/Mac OS 8.5/8.5.1/8.6/9.0	Windows 95/98 SE/2000 Professional/ NT4.0/ME/Mac OS 8.5/8.5.1/8.6/9.0
Utility Software	Yes (Maintenance Soft)	Yes (Maintenance Soft)
Bundled Cable	No	No
Network	No	No
Variable Dot Print	Yes (3 sizes, Min. 8pl)	Yes (3 sizes, Min. 8pl)
Shingling Print	No	No
Color Enhancement	Yes	Yes
COPY		
Color/Mono	Color/Mono	Color/Mono
Speed (ppm)	3.1/2.9 (Full Scan)	3.1/2.9 (Full Scan)
Multi Copy (Stack)	Yes (Color 300 dpi) or Via PC	Yes (Color 300 dpi) or Via PC
Multi Copy (Sort)	Yes (B&W only) or Via PC	Yes (B&W only) or Via PC
Reduction/Enlargement	25% to 400% in 1% increments	25% to 400% in 1% increments
Resolution (dpi)	Max. 1200 x 1200	Max. 1200 x 1200
N in 1	B&W only (2 in 1/4 in 1), Letter, A4 only	B&W only (2 in 1/4 in 1), Letter, A4 only
Poster	No	No
Image Enhancement	No	No
SCANNER		
Color/Mono	Color/Mono	Color/Mono
Resolution(dpi) (Physical)	300 x 600 (Opt.)	300 x 600 (Opt.)
Resolution(dpi) (Logical)	2400 (Int.)	2400 (Int.)
Speed	Min. 3 sec.	Min. 3 sec.
Gray Scale	256	256
TWAIN Compliant & Operating System	Windows 95/98 SE/2000 Professional/ NT4.0/ME/Mac OS 8.6/9.0	Windows 95/98 SE/2000 Professional/ NT4.0/ME/Mac OS 8.6/9.0

Model Name	MFC830 (Fax/Copy/Print/Scan/Video Capture)	MFC840 (Fax/Copy/Print/Scan/PhotoCapture Centre/ Video Capture)
Speed (ppm)	12/10 (Mono/Color)	12/10 (Mono/Color)
ASF Capacity (sheets)	100	100
Additional ASF (sheets)	No	No
Output Paper Tray Capacity (sheets)	50	50
Standard Print Language	Windows GDI	Windows GDI
Emulation	No	No
Resident Fonts	No	No
Fonts Disk Based	Yes	Yes
Paper Handling Size	LTR, LGL, A4, B5, A5, EXE	LTR, LGL, A4, B5, A5, EXE
Manual Feed Slot	N/A	N/A
Other Paper Type	OHP, Envelopes, Labels, Organizer	OHP, Envelopes, Labels, Organizer
Sheet Weight (ASF) (Manual Slot)	64 to 105 g/m ² (17 to 28 lb) N/A	64 to 105 g/m ² (17 to 28 lb) N/A
Printer Driver	Windows 95/98 SE/2000 Professional/ NT4.0/ME/Mac OS 8.5/8.5.1/8.6/9.0	Windows 95/98 SE/2000 Professional/ NT4.0/ME/Mac OS 8.5/8.5.1/8.6/9.0
Utility Software	Yes (Maintenance Software)	Yes (Maintenance Software)
Bundled Cable	No	No
Network	No	No
Variable Dot Print	Yes (3 sizes, Min. 8pl)	Yes (3 sizes, Min. 8pl)
Shingling Print	No	No
Image Enhancement	Yes	Yes
COPY		
Color/Mono	Color/Mono	Color/Mono
Speed (ppm)	4/7 (color/mono)	4/7 (color/mono)
Multi Copy (Stack)	Yes (B&W) or Via PC	Yes (B&W) or Via PC
Multi Copy (Sort)	Yes (B&W) or Via PC	Yes (B&W) or Via PC
Reduction/Enlargement	25% to 400% in 1% increments	25% to 400% in 1% increments
Resolution (dpi)	Max. 1200 x 1200	Max. 1200 x 1200
N in 1	B&W only (2 in 1/4 in 1), Letter, A4 only	B&W only (2 in 1/4 in 1), Letter, A4 only
Poster	No	No
Image Enhancement	No	No
SCANNER		
Color/Mono	Color/Mono	Color/Mono
Resolution (dpi) (Physical)	300 x 600 (Opt.)	300 x 600 (Opt.)
Resolution (dpi) (Logical)	2400 (Int.)	2400 (Int.)
Speed	Min. 3 sec. (300 x 150 dpi)	Min. 3 sec. (300 x 150 dpi)
Gray Scale	256	256
TWAIN Compliant & Operating System	Windows 95/98 SE/2000 Professional/ NT4.0/ME/Mac OS 8.6/9.0	Windows 95/98 SE/2000 Professional/ NT4.0/ME/Mac OS 8.6/9.0
PCI Scanner (Parallel/Serial)	Parallel/USB	Parallel/USB
E-MAIL Scan Key	Yes	Yes
OCR Scan Key	Yes	Yes

Model Name	MFC7300C (Fax/Copy/Print/Scan/Video Capture)	MFC7400C (Fax/Copy/Print/Scan/PhotoCapture Center/Video Capture/PC-Fax)
PCI Scanner (Parallel/Serial)	Parallel/USB	Parallel/USB
E-MAIL Scan Key	Yes	Yes
OCR Scan Key	Yes	Yes
Scan Key	Yes	Yes
Color Depth	30-bit color	30-bit color
MESSAGE CENTER/MESSAGE MANAGER		
ICM Recording Time	N/A	N/A
Page Memory	N/A	N/A
OGM (MC;MC Pro;Paging;F/T)	N/A	N/A
TAD Type	N/A	N/A
Memo/Recording Conversation	N/A	N/A
Fax Forwarding	Yes (B&W only)	Yes (B&W only)
Fax Retrieval	Yes (B&W only)	Yes (B&W only)
Paging	Yes	Yes
Remote Access	Yes	Yes
Toll Saver	N/A	N/A
MESSAGE CENTER Pro/ MESSAGE MANAGER Pro		
Fax/Voice Mailbox	N/A	N/A
Fax-/Voice-on-Demand	N/A	N/A
MESSAGE CENTER (PC MC)		
Fax Forwarding	N/A	N/A
Paging	N/A	N/A
ICM Recording Time	N/A	N/A
OGM MC;MC Pro;Paging	N/A	N/A
Fax/Voice Mailbox	N/A	N/A
Fax-/Voice-on-Demand	N/A	N/A
VIDEO CAPTURE		
Video Capture	Yes	Yes
Video Print	Yes	Yes
Video Format	Yes (NTSC)	Yes (NTSC)
Video Fax	No	No
PHOTOCAPTURE CENTER		
Acceptable Media	N/A	SmartMedia/Compact Flash
Print	N/A	Yes (color)
Media Format	N/A	DPOF

Model Name	MFC830 (Fax/Copy/Print/Scan/Video Capture)	MFC840 (Fax/Copy/Print/Scan/PhotoCapture Centre/ Video Capture)
Scan Key	Yes	Yes
Color Depth	30-bit color	30-bit color
MESSAGE CENTER/MESSAGE MANAGER		
ICM Recording Time	N/A	N/A
Page Memory	N/A	N/A
OGM (MC;MC Pro;Paging;F/T)	N/A	N/A
TAD Type	N/A	N/A
Memo/Recording Conversation	N/A	N/A
Fax Forwarding	Yes (B&W only)	Yes (B&W only)
Fax Retrieval	Yes (B&W only)	Yes (B&W only)
Paging	N/A	N/A
Remote Access	Yes	Yes
Toll Saver	N/A	N/A
MESSAGE CENTER Pro/MESSAGE MANAGER Pro		
Fax/Voice Mailbox	N/A	N/A
Fax-/Voice-on-Demand	N/A	N/A
MESSAGE CENTER (PC MC)		
Fax Forwarding	N/A	N/A
Paging	N/A	N/A
ICM Recording Time	N/A	N/A
OGM MC;MC Pro;Paging	N/A	N/A
Fax/Voice Mailbox	N/A	N/A
Fax-/Voice-on-Demand	N/A	N/A
VIDEO CAPTURE		
Video Capture	Yes	Yes
Video Print	Yes	Yes
Video Format	Yes (PAL)	Yes (PAL)
Video Fax	No	No
PHOTOCAPTURE CENTER		
Acceptable Media	N/A	SmartMedia/Compact Flash
Print	N/A	Yes (Color)
Media Format	N/A	DPOF
Image Format	N/A	JPEG
Image Enhancement	N/A	Yes
Media Drive	N/A	Yes (USB except i-Mac/Windows NT4.0)

Model Name	MFC7300C (Fax/Copy/Print/Scan/Video Capture)	MFC7400C (Fax/Copy/Print/Scan/PhotoCapture Center/Video Capture/PC-Fax)
Image Format	N/A	JPEG
Image Enhancement	N/A	Yes
Media Drive	N/A	Yes (USB except i-Mac/Windows NT4.0)
BUNDLED SOFTWARE (For Windows)		
Printer Driver	Brother	Brother
TWAIN	Brother	Brother
Viewer	Scan Soft	Scan Soft
PC Fax	No	SMSI
Others	Auto E-mail Printing (Windows 95/98 only)	Auto E-mail Printing (Windows 95/98 only)
Formats (Import)	TIFF/BMP/PCX/DCX/ BTF/BTX/MAX/PDF	TIFF/BMP/PCX/DCX/ BTF/BTX/MAX/PDF
Formats (Export)	TIFF/BMP/MAX/PDF	TIFF/BMP/MAX/PDF
OCR	Yes (ScanSoft TextBridge)	Yes (ScanSoft TextBridge)
Pop-Up Menu	Yes	Yes
Remote Setup	Yes	Yes
PC Diagnostics	Yes	Yes
BUNDLED SOFTWARE (For i-MAC)		
Printer Driver	Brother	Brother
TWAIN	Brother	Brother
Viewer	Scan Soft	Scan Soft
PC Fax	No	No
Others	No	No
Formats(Import)	-	-
Formats(Export)	-	-
OCR	Mac OS 8.6/9.0	Mac OS 8.6/9.0
Pop-Up Menu	No	No
Remote Setup	No	No
PC Diagnostics	No	No
ACCESSORY		
Life of Ink Cartridges	4 colors (each separate tank)	4 colors (each separate tank)
	Black: 850 pages, Color: 410 pages	Black: 850 pages, Color: 410 pages

Model Name	MFC830 (Fax/Copy/Print/Scan/Video Capture)	MFC840 (Fax/Copy/Print/Scan/PhotoCapture Centre/ Video Capture)
BUNDLED SOFTWARE (For Windows)		
Printer Driver	Brother	Brother
TWAIN	Brother	Brother
Viewer	Scan Soft	Scan Soft
PC Fax	N/A	N/A
Others	Auto E-mail Printing (Windows 95/98 only)	Auto E-mail Printing (Windows 95/98 only)
Formats (Import)	TIFF/BMP/PCX/DCX/ BTF/BTX/MAX/PDF	TIFF/BMP/PCX/DCX/ BTF/BTX/MAX/PDF
Formats (Export)	TIFF/BMP/MAX/PDF	TIFF/BMP/MAX/PDF
OCR	Yes (ScanSoft TextBridge)	Yes (ScanSoft TextBridge)
Pop-UP Menu	Yes	Yes
Remote Setup	Yes	Yes
PC Diagnostics	Yes	Yes
BUNDLED SOFTWARE (For iMAC)		
Printer Driver	Brother	Brother
TWAIN	Brother	Brother
Viewer	N/A	N/A
PC Fax	No	No
Others	No	No
Formats (Import)	-	-
Formats (Export)	-	-
OCR	Mac OS 8.6/9.0	Mac OS 8.6/9.0
Pop-Up Menu	No	No
Remote Setup	No	No
PC Diagnostics	No	No
ACCESSORY		
Life of Ink Cartridges	4 colors (each separate tank)	4 colors (each separate tank)
	Black: 850 pages, Color: 410 pages	Black: 850 pages, Color: 410 pages

1. INSTALLING THE UPDATE DATA TO THE FACSIMILE EQUIPMENT

If the program version is updated or the main PCB is replaced, install the update program onto the flash ROM of the main PCB.

The program installation requires a PC/AT-compatible computer (which is capable of running MS-DOS or its compatible OS).

Connecting the facsimile equipment to your computer

- (1) Make sure that the equipment's power cord is unplugged from a wall socket.
- (2) Make sure that your computer is turned off.
- (3) Connect the interface cable to the parallel interface port on the back of the equipment and secure it with the lock wires.
- (4) Connect the other end of the interface cable to the printer port of your computer and secure it with the two screws.
- (5) Turn on your computer.
- (6) Plug the equipment's power cord into a wall socket.

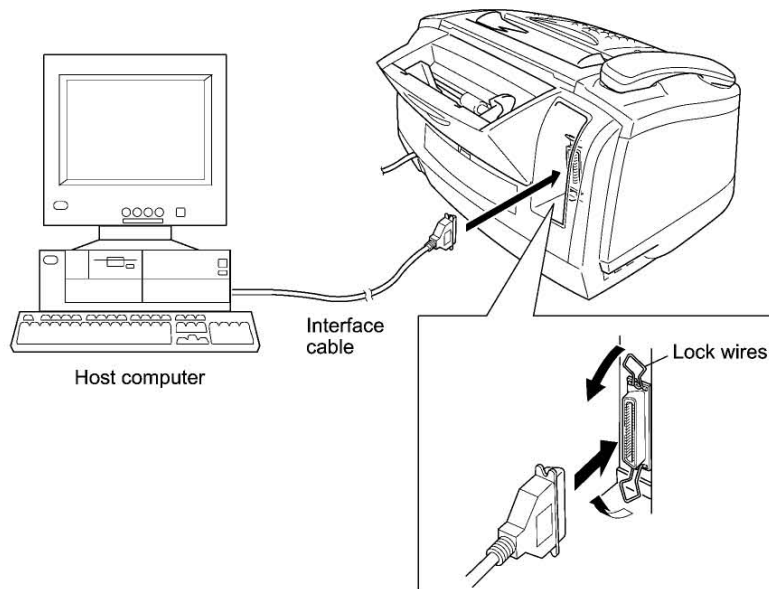

Installing the update data onto the flash ROM of the facsimile equipment

NOTE: The following is an installation procedure example on a PC that is running Windows 95/98.

- (1) Copy the update data and transfer utility onto the desired directory of the hard disk.
e.g., C:\UPDATE
- (2) Click the Start button, point to Programs, and then click MS-DOS Prompt to open an MS-DOS window.
- (3) Type the drive letter where the update data and transfer utility are located. In the above example, type C:\ from the command line and press the **ENTER** key.

Then type CD UPDATE and press the **ENTER** key.

- (4) Check that your computer is connected with the facsimile equipment correctly.
- (5) To start the transfer utility transmitting the update data to the flash ROM of the facsimile equipment, type the following:

```
ICEN filename /b
```

Then press the **ENTER** key.

During downloading, the equipment beeps *intermittently*.

Upon completion of the downloading, the equipment beeps *continuously*.

NOTE: If the facsimile equipment cannot return to the standby state after completion of downloading, turn the equipment off and on.

1. OVERVIEW

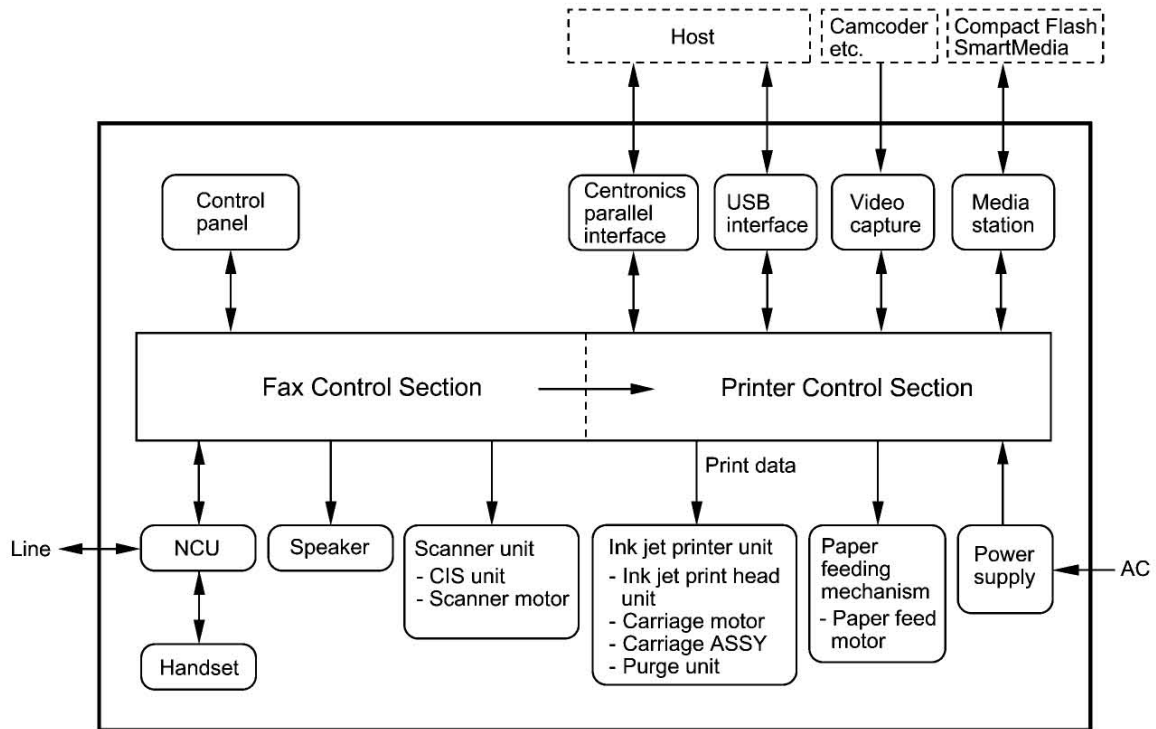

2. MECHANISMS

The equipment is classified into the following mechanisms:

- SCANNER MECHANISM
 - Document feeding and ejecting mechanism
 - Document scanning mechanism

- INK JET PRINTING MECHANISM
 - Paper pulling-in, registration, feeding, and ejecting mechanisms
 - Ink jet printing and head capping mechanisms
 - Purging mechanism
 - Carriage drive mechanism

- SENSORS AND ACTUATORS

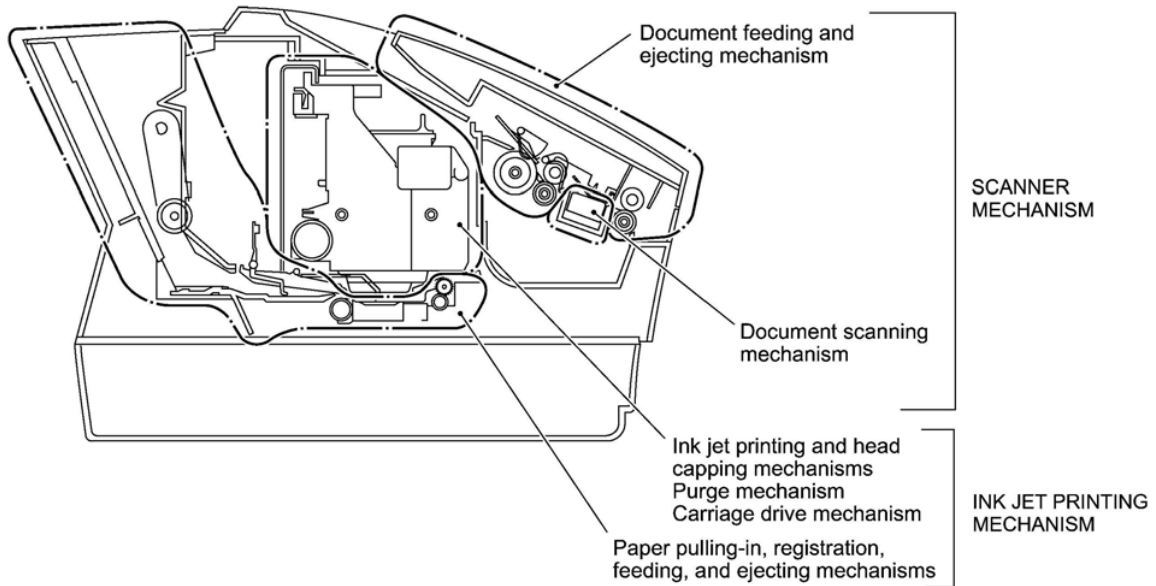

2.1 Scanner Mechanism

This mechanism consists of the document stacker, automatic document feeder (ADF), document feed roller ASSY, document ejection roller ASSY, and document sensors. (For details about the sensors, refer to Section 2.3.)

If you set documents with their faces down on the document stacker and starts the scanning operation, the scanner motor rotates so that the ADF (which consists of the separation roller ASSY and ADF parts) feeds those documents into the equipment, starting from the bottom sheet (first page) to the top (last page), page by page. Each document advances with the document feed roller ASSY to the scanner, and then it is fed out of the equipment with the document ejection roller ASSY.

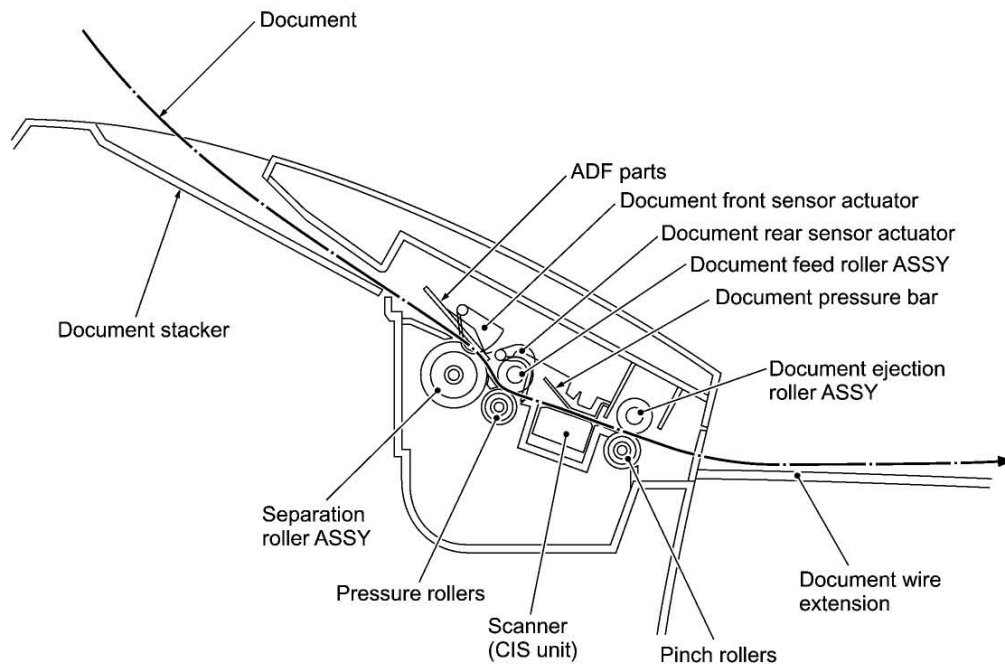

Scanner

The scanner uses a contact image sensor (CIS) unit which consists of an LED array illuminating documents, a self-focus lens array collecting the reflected light, a CIS PCB carrying out photoelectric conversion to output picture element data, and a cover glass on which a document advances. When the document passes between the document pressure bar and the cover glass, it is scanned.

2.2 Ink Jet Printing Mechanism

2.2.1 Paper pulling-in, registration, feeding, and ejecting mechanisms

The paper pulling-in, registration, feeding, and ejecting mechanisms are driven by a single paper feed motor (stepping motor) via the two PF timing belts and gear train.

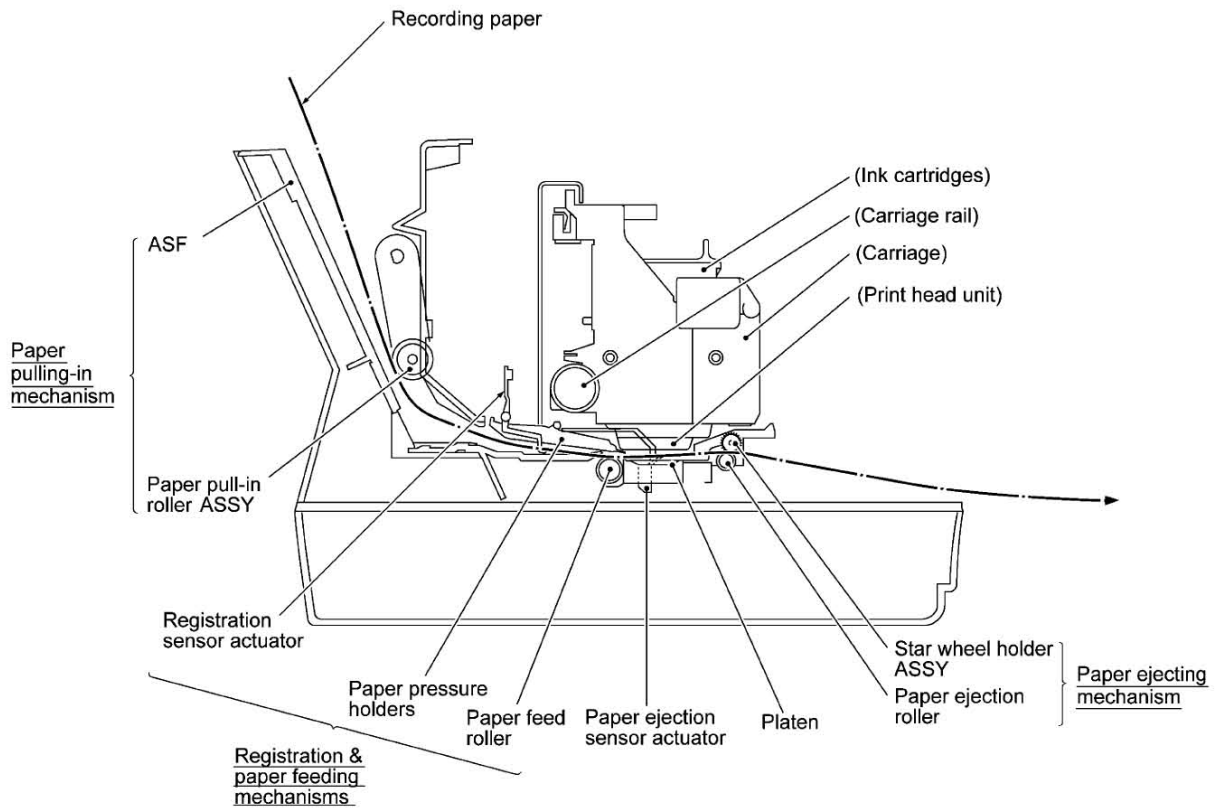

2.2.2 Ink jet printing and capping mechanisms

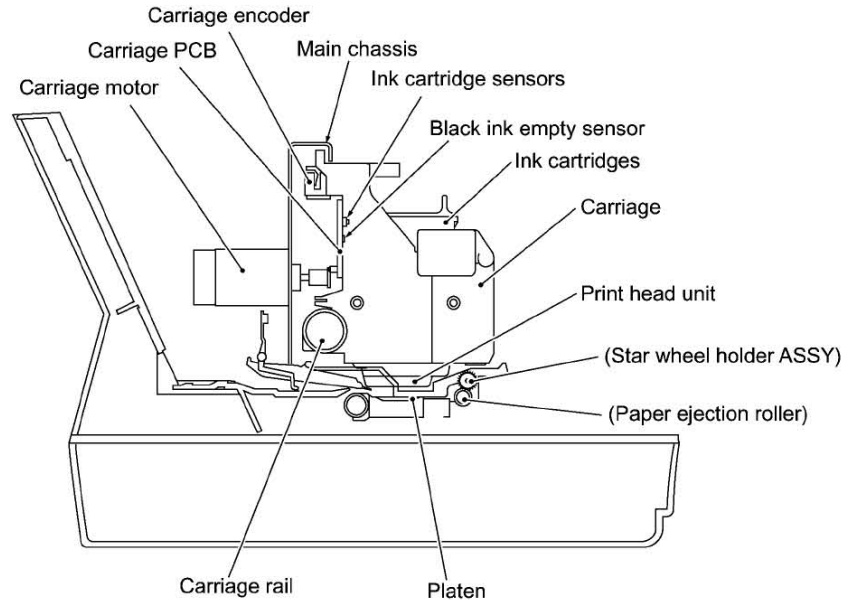

(1) Print head

This equipment uses drop-on-demand ink jet printing. Each of the right and left print heads has an ink-jet unit that has a pair of nozzle arrays for two color inks. A nozzle array consists of 114 nozzles, 114 channels sandwiched by a pair of piezoelectric ceramic actuators (PZT), manifold, and filter. As illustrated below, 109 channels from #4 to #112 are usable, but 107 channels out of them will be used in actual printing. Two channels are prepared for covering a vertical alignment error between the right and left print heads.

If a drive voltage* is applied to the electrodes formed on the surface of the piezoelectric actuators, those actuators will be distorted as shown with broken lines on the next page so that the ink in the manifold will be vacuumed out to the channel.

(*The controller switches the drive voltage between 36 levels within 8.5V to 24V depending upon the ambient temperature detected by the head thermistor.)

If deenergized, the piezoelectric actuators return to the previous form so as to apply pressure to the ink in the channel, causing the ink to jet out through the nozzle. The jetted-out ink drop will be splashed and produce a dot on paper held by the platen.

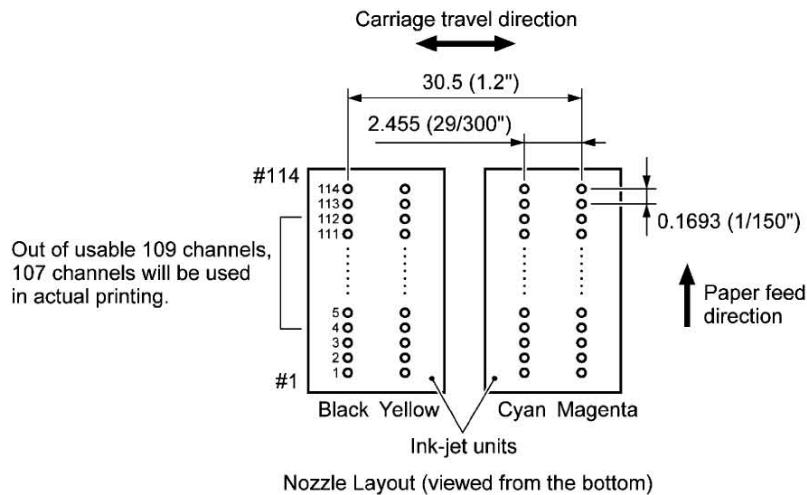

As the carriage holding the print heads travels at the printing speed, the controller sends print command pulses to the circuits driving the piezoelectric actuators embedded in the print heads.

For the head thermistor and the head property EEPROMs, refer to Section 2.3.

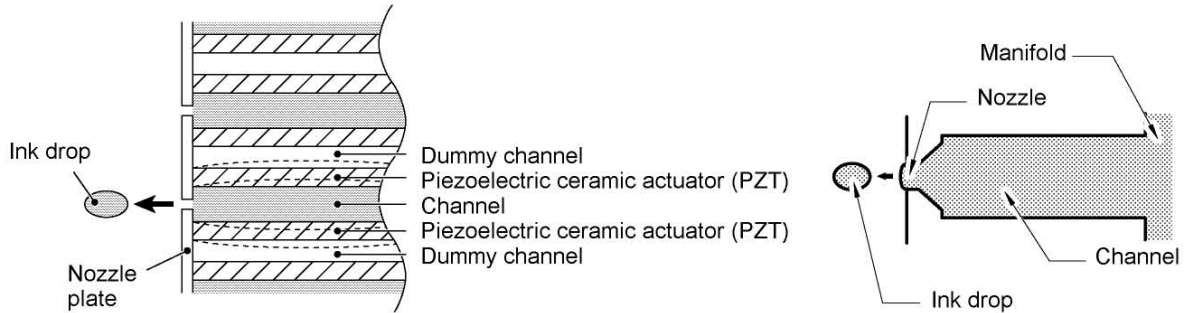

(2) Ink cartridge

The equipment uses four ink cartridges (black, yellow, cyan, and magenta) of disposable type to supply ink to the print head. As shown below, an ink cartridge contains an ink-impregnated urethane foam. If ink-jet print operation or purging operation takes place, ink comes out of the urethane foam and is supplied to the print head through the ink room, filters, and manifold.

For the ink cartridge sensors on the carriage PCB, refer to Section 2.3.

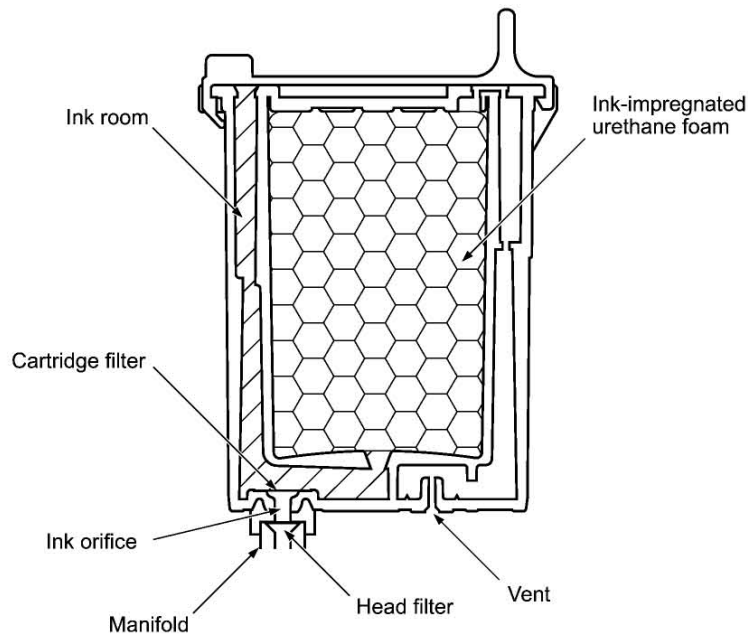

(3) Head cap

Shown below is a head cap mechanism that prevents the nozzles of the print heads from drying up when they are not in use.

Upon completion of printing, the carriage travels to the right and moves the head cap holder provided on the purge unit to the right together. In the head cap holder are two head caps, each of which is supported with a lift lever. The rightward movement of the head cap holder turns the lift levers and pushes up the head caps to the position where the head caps come into tight contact with the print heads. This way, the nozzles will be capped.

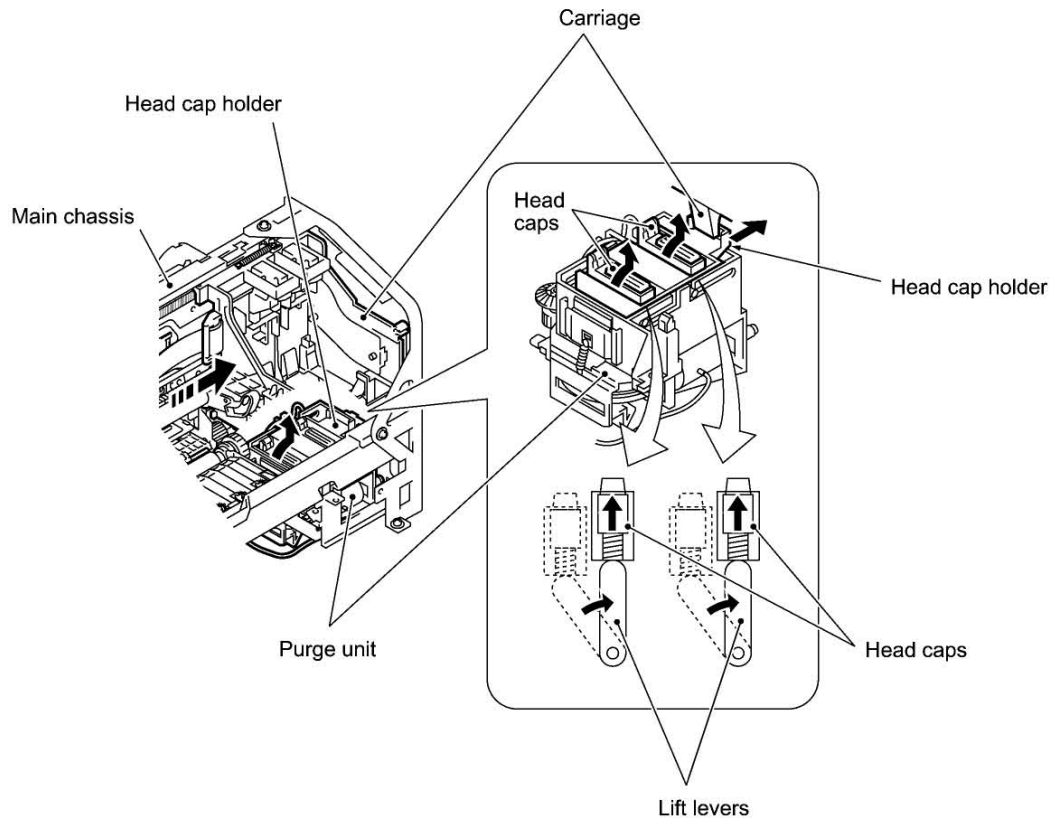

2.2.3 Purging mechanism

The purging mechanism is driven by the paper feed motor located at the left side of the main chassis. The rotation of the paper feed motor is transmitted via the PF timing belt L to the paper feed roller. At the right end of the paper feed roller is the PF roller gear R which is always engaged with the purge gear 18. Engaged with the purge gear 18, the purge gear 19 works as a clutch gear which engages with or disengages from the purge bevel gear 18 as illustrated on the next page.

When the carriage travels from the left to right to reach the purge position, the tab provided on the back of the carriage pushes the purge lever on the main chassis to the right (see the illustration below). Accordingly, the purge gear 19 (which was shifted to the left by the purge lever) will move to the right by the spring so as to be engaged with the purge bevel gear 18. This engagement will transmit the motor rotation to the purge unit.

On the contrary, if the carriage travels from the purge position to the left, the tab on the back of the carriage releases the purge lever which will be pulled back to the left. The purge gear 19 will be disengaged from the purge bevel gear 18, where the purge gear 19 will simply idle and no rotation will be transmitted to the purge unit.

That is, when the carriage is in printing operation, no rotation of the paper feed motor is transmitted to the purge unit; when the carriage is in the purge position, the motor rotation is transmitted to the purge unit.

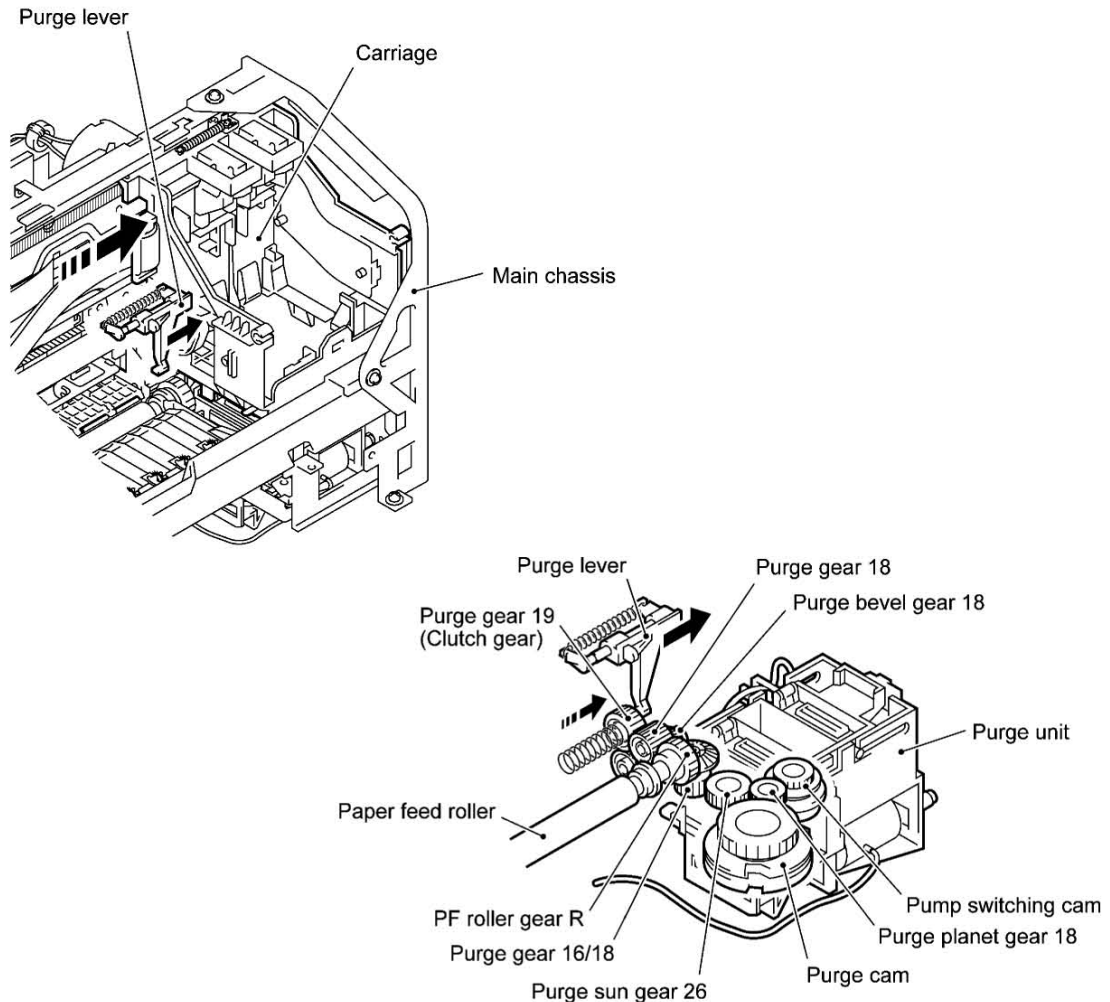

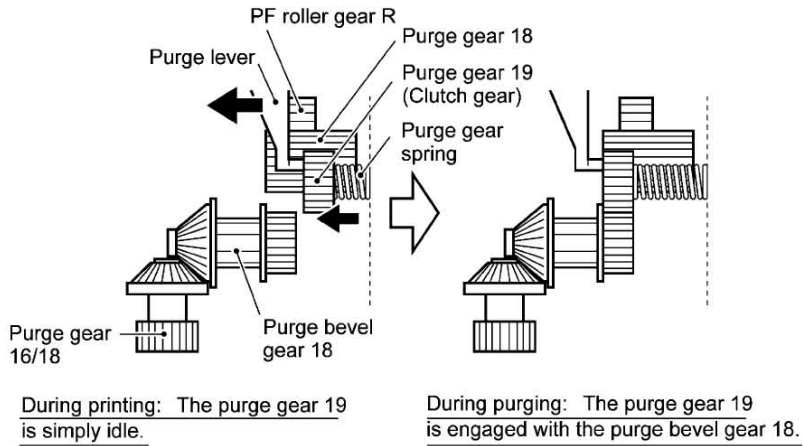

If the paper feed motor rotates in the forward direction when the motor rotation is transmitted to the purge unit, the purge cam will be driven; if in the backward direction, the pump switching unit will be driven.

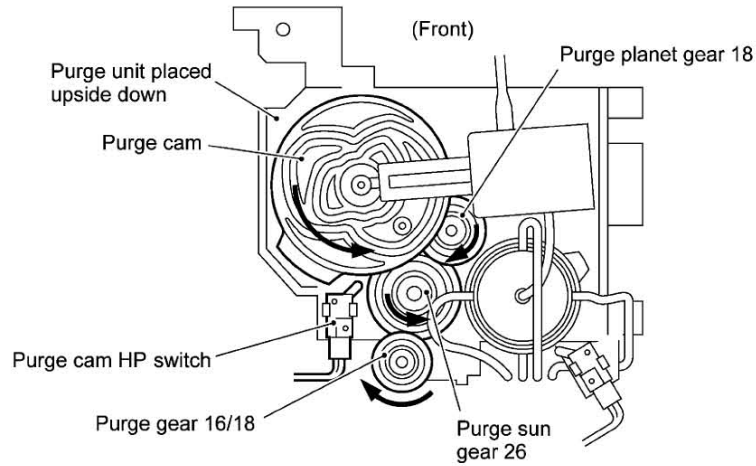

When the paper feed motor rotates in the forward direction

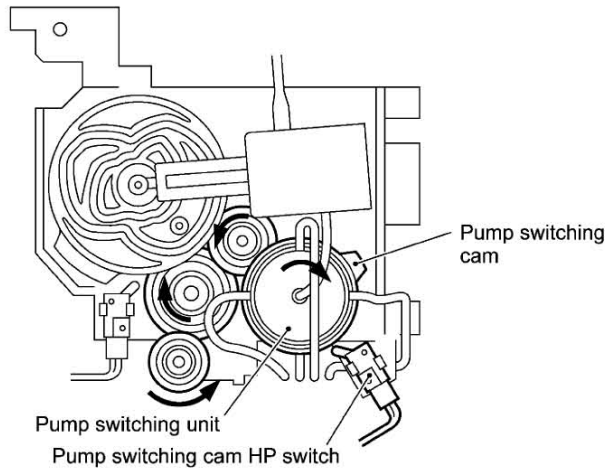

When the paper feed motor rotates in the backward direction

The purge cam is so designed that:

- the carriage lock pops out to lock the carriage before purging and pops in before cleaning with the head wiper (see the illustration below),
- the pump works to draw out ink from each of the four head nozzles and drain it to the ink absorber felts, and
- the head wiper comes out to clean the nozzle surface (see the illustration below).

The pump switching cam is so designed that:

- the pump switching unit switches application of the pump's negative pressure between the four head nozzles in the order of black, yellow, cyan, and magenta nozzles. When the pump switching cam is in the home position, normal atmospheric pressure will be restored.

The home position of the purge cam and pump switching cam are detected by their HP switches. For those switches, refer to Section 2.3.

(1) Carriage lock

If the purge cam is driven, the carriage lock of the purge unit pops out and locks the carriage to align ink-jet units with the mating purge caps during purging operation. After purging but before cleaning with the head wiper, it pops in to release the carriage. When the power is off, the carriage lock keeps the print heads pressed against the head caps.

(2) Purging

If activated, the pump draws out ink to purge air bubbles or dust from the inside of the head nozzles and channels. As the purge cam rotates by one turn, the piston of the pump reciprocates two strokes. To complete purging of all four nozzles and channels, the purge cam rotates by two turns and the piston reciprocates four strokes.

(3) Draining

The pump drains drawn ink into the ink absorber felts.

(4) Cleaning with the head wiper

After purging operation, the head wiper comes out and the carriage moves from the right to left so as to clean ink remaining on the heads' surface.

(5) Restoring the pump's pressure to normal atmospheric pressure

When the pump switching cam is in the home position, the controller stops to produce negative pressure and restore the pump's pressure to normal atmospheric pressure.

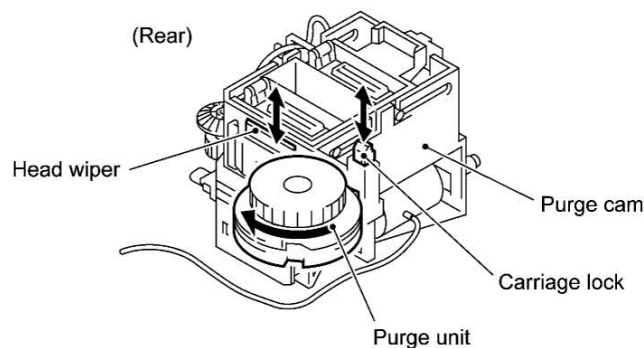

2.2.4 Carriage drive mechanism

The carriage motor controls horizontal motion. The motor rotation is transmitted via the motor pulley to the carriage timing belt.

The carriage, which is supported and guided by the carriage rail, is secured to the carriage timing belt. Clockwise and counterclockwise rotations of the carriage motor move the carriage to the right and left, respectively.

On the back of the carriage is the carriage encoder which tells the control circuitry the current carriage position counted based on the carriage home position by using the encoder strip attached to the main chassis.

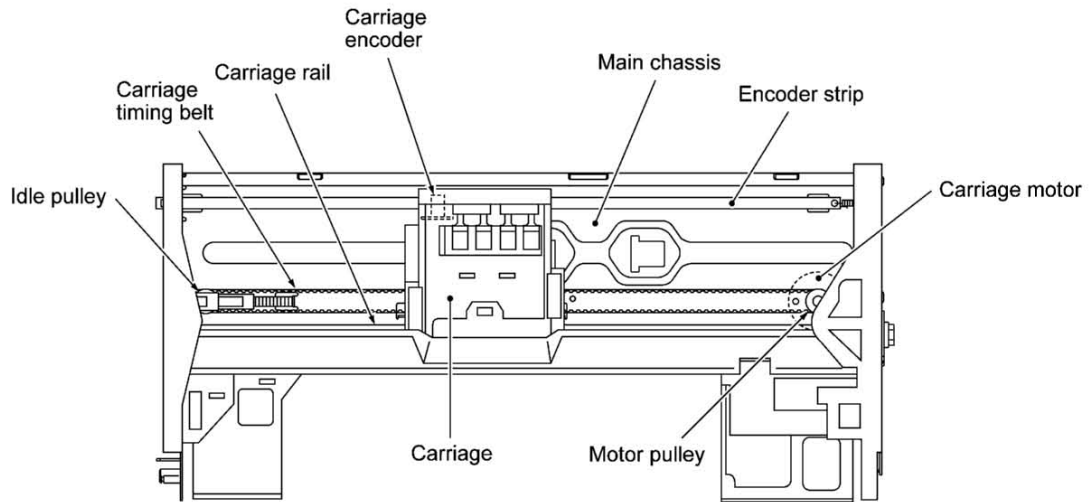

2.3 Sensors and Actuators

This equipment has the following sensors and thermistor.

Sensor name	Type	Located on
Cover/panel open sensor	Photosensor	Upper cover
Registration sensor	Photosensor	Main PCB
Paper ejection sensor	Photosensor	Platen
Document front sensor	Photosensor	Document sensor PCB
Document rear sensor	Photosensor	Document sensor PCB
Ink cartridge sensors	Mechanical switches	Carriage PCB
Black ink empty sensor	Photosensor	Carriage PCB
Carriage encoder	Photosensor	Carriage PCB
Head thermistor	Thermistor	Carriage PCB
Head property EEPROM on each head	---	Head PCB on each of the right and left print heads
Purge cam HP switch	Mechanical switch	Purge unit
Pump switching cam HP switch	Mechanical switch	Purge unit
Hook switch*	Mechanical switch	Hook switch PCB

*For models w/ handset

- Cover/panel open sensor which detects whether the top cover and control panel are closed.
- Registration sensor which detects the leading and trailing edges of paper, which allows the controller to determine the registration timing and check paper jam.
- Paper ejection sensor which detects whether the paper goes out of the equipment.
- Document front sensor which detects the presence of documents.
- Document rear sensor which detects the leading and trailing edges of pages to tell the control circuitry when the leading edge of a new page has reached the starting position and when the scan for that page is over.
- Ink cartridge sensors, each of which detects whether an ink cartridge is loaded.
- Black ink empty sensor which detects whether the black ink cartridge is empty.
- Carriage encoder which detects the current carriage position and carriage travel speed. If the carriage travel speed varies abnormally, the controller regards it as a paper jam.
- Head thermistor which allows the controller to control the temperature of the print heads. According to the change of the thermistor's internal resistance monitored, the control circuitry regulates the drive voltage applied to the piezoelectric ceramic actuators on each print head since the viscosity of the ink varies depending upon the temperature.

- Head property EEPROM which stores the head property information on each print head, as well as including a jetted-out ink drops counter and correction values of the black ink empty sensor. If you set the right or left print head on the carriage, the control circuitry on the main PCB reads the information and regulates the drive voltage applied to the head's piezoelectric ceramic actuators.
- Purge cam HP switch which detects whether the purge cam is in the home position.
- Pump switching cam HP switch which detects whether the pump switching cam is in the home position.
- Hook switch which detects whether the handset is placed on the handset mount.

The above photosensors are a photointerrupter consisting of a light-emitting diode and a light-sensitive transistor. Each of them has an actuator separately arranged as shown on the next page.

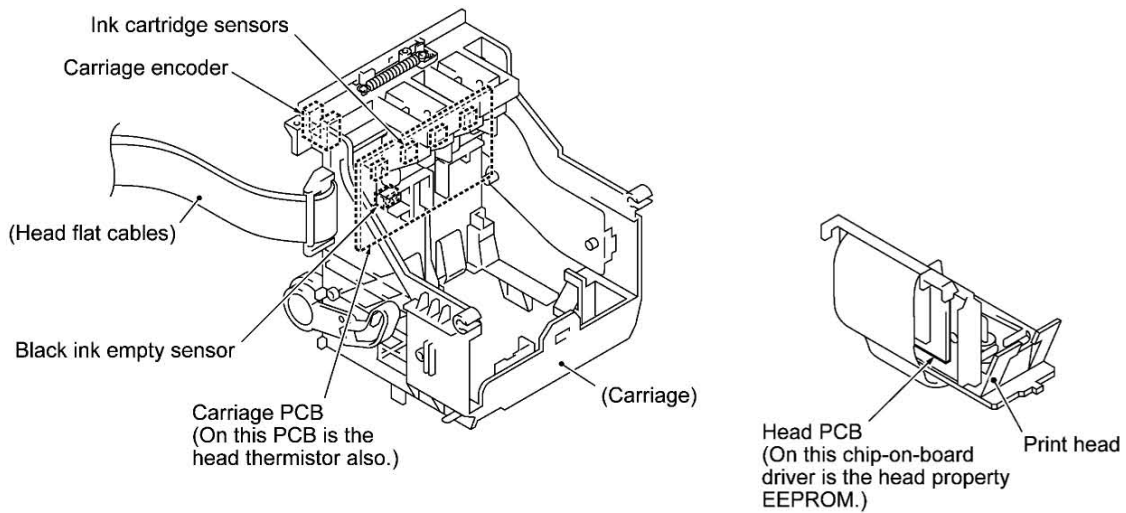
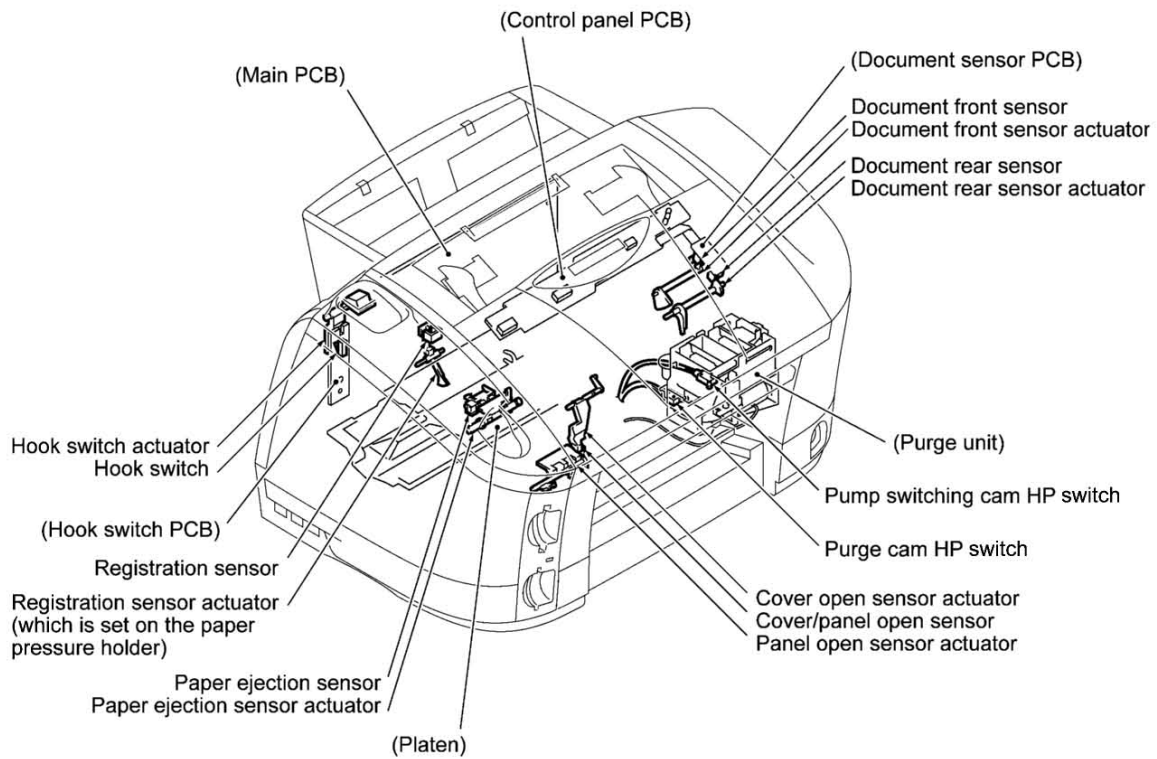

Location of Sensors and Actuators

3. CONTROL ELECTRONICS

3.1 Configuration

The hardware configuration of the facsimile equipment is shown below.

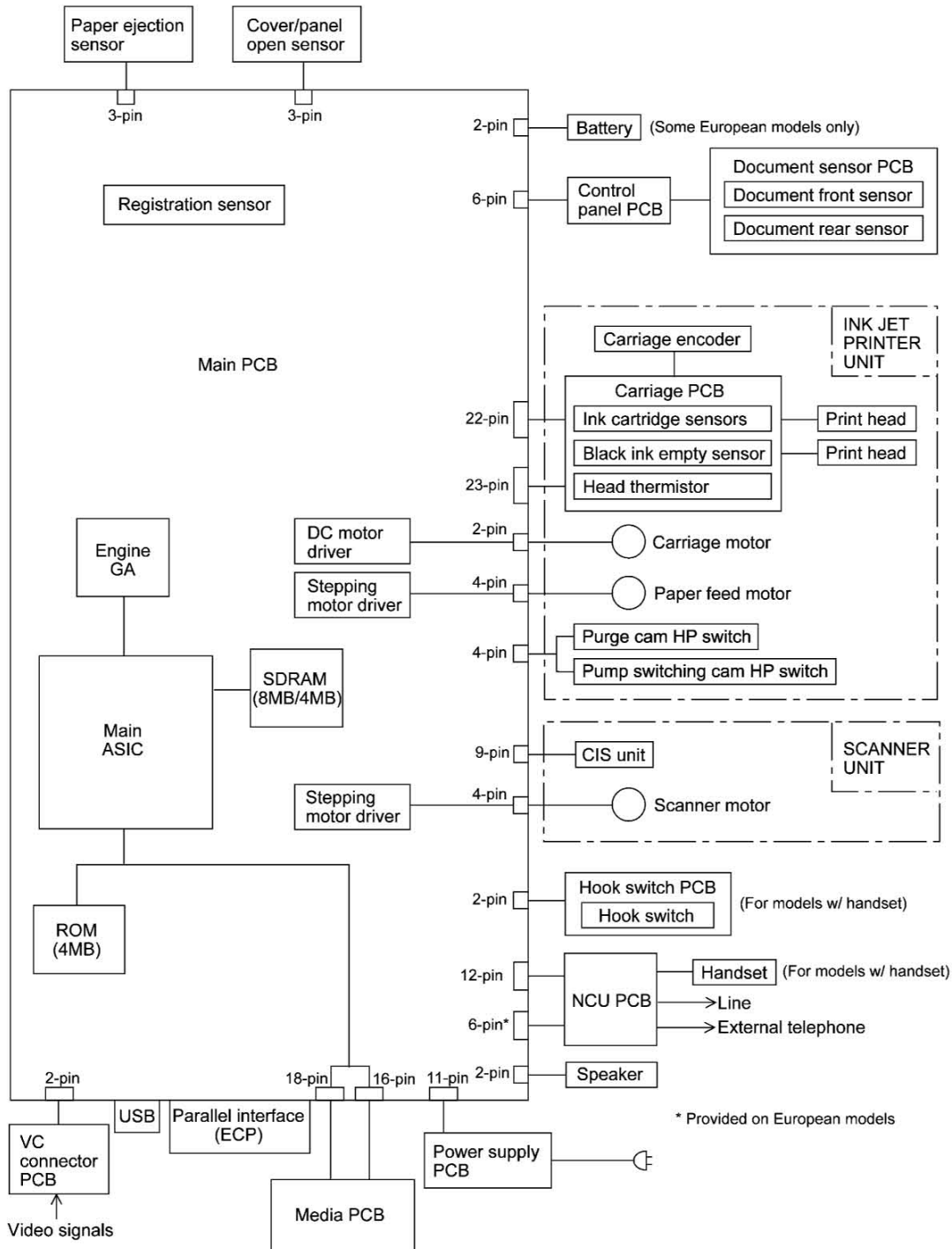

Configuration of Facsimile Equipment

1. DISASSEMBLY/REASSEMBLY

■ Safety Precautions

To prevent the creation of secondary problems by mishandling, observe the following precautions during maintenance work.

- (1) Unplug the power cord from the power outlet before replacing parts or units. When having access to the power supply, be sure to unplug the power cord from the power outlet.
- (2) Be careful not to lose screws, washers, or other parts removed for parts replacement.
- (3) When using soldering irons and other heat-generating tools, take care not to damage the resin parts such as wires, PCBs, and covers.
- (4) Before handling the PCBs, touch a metal portion of the equipment to discharge static electricity; otherwise, the electronic parts may be damaged due to the electricity charged in your body.
- (5) When transporting PCBs, be sure to wrap them in conductive sheets such as aluminum foil.
- (6) Be sure to reinsert self-tapping screws correctly, if removed.
- (7) Tighten screws to the torque values listed on the following pages.
- (8) When connecting or disconnecting cable connectors, hold the connector bodies not the cables. If the connector has a lock, always slide the connector lock to unlock it.
- (9) Before reassembly, apply the specified lubricant to the specified points. (Refer to Section 2 in this chapter.)
- (10) After repairs, check not only the repaired portion but also that the connectors and other related portions function properly before operation checks.
- (11) Once the print head prints, it will start head locking operation after five seconds from the end of printing. The head locking operation will take 5 to 10 seconds. NEVER unplug the power cord before the equipment completes the head locking operation; doing so will make the print head unusable and require replacement with a new print head.

When you receive the equipment from the user or when you pack it for sending it back to the user, check the head locking state.

Tightening Torque List

Location	Screw type	Q'ty	Tightening torque N•m (kgf•cm)	Loosening torque N•m (kgf•cm)
ADF parts	Taptite, pan B M3x6	1	0.49 ±0.10 (5 ±1)	Min. 0.20 (2.0)
Panel rear cover	Taptite, cup B M3x8	2	0.49 ±0.10 (5 ±1)	Min. 0.20 (2.0)
Scanner frame ASSY	Taptite, cup B M3x10	2	0.78 ±0.10 (8 ±1)	Min. 0.20 (2.0)
Pinch roller leaf spring	Taptite, cup B M3x8	1	0.78 ±0.10 (8 ±1)	Min. 0.20 (2.0)
Scanner drive ASSY	Taptite, cup B M3x8	2	0.78 ±0.10 (8 ±1)	Min. 0.20 (2.0)
Scanner motor	Screw, pan (s/p washer) M3x6DB	1	0.69 ±0.10 (7 ±1)	Min. 0.20 (2.0)
Rear cover	Taptite, cup B M4x12	2	0.98 ±0.10 (10 ±1)	Min. 0.29 (3.0)
ASF	Taptite, cup S M3x6	3	0.78 ±0.10 (8 ±1)	Min. 0.20 (2.0)
Upper cover	Taptite, cup B M4x12	2	0.98 ±0.10 (10 ±1)	Min. 0.29 (3.0)
Hook switch PCB	Taptite, cup S M3x6	1	0.78 ±0.10 (8 ±1)	Min. 0.20 (2.0)
PCB support	Taptite, cup S M3x6	1	0.78 ±0.10 (8 ±1)	Min. 0.20 (2.0)
Main PCB	Taptite, cup S M3x6	2	0.78 ±0.10 (8 ±1)	Min. 0.20 (2.0)
	Taptite, pan S M3x12	2	0.78 ±0.10 (8 ±1)	Min. 0.20 (2.0)
Main shield plate	Taptite, cup S M3x6	1	0.78 ±0.10 (8 ±1)	Min. 0.20 (2.0)
Media shield plate	Taptite, cup S M3x6	1	0.78 ±0.10 (8 ±1)	Min. 0.20 (2.0)
	Taptite, cup B M3x8	2	0.78 ±0.10 (8 ±1)	Min. 0.20 (2.0)
Media PCB	Taptite, cup S M3x6	2	0.78 ±0.10 (8 ±1)	Min. 0.20 (2.0)
VC bracket	Taptite, cup S M3x6	1	0.98 ±0.10 (10 ±1)	Min. 0.20 (2.0)
	Taptite, cup B M3x8	1	0.78 ±0.10 (8 ±1)	Min. 0.20 (2.0)
VC connector PCB	Taptite, cup S M3x6	1	0.98 ±0.10 (10 ±1)	Min. 0.20 (2.0)
NCU/PS shield box	Taptite, cup B M3x8	2	0.78 ±0.10 (8 ±1)	Min. 0.20 (2.0)
	Taptite, cup S M3x6	1	0.78 ±0.10 (8 ±1)	Min. 0.20 (2.0)
Grounding plate	Taptite, cup S M3x6	1	0.78 ±0.10 (8 ±1)	Min. 0.20 (2.0)
Upper NCU/PS shield	Taptite, cup S M3x6	2	0.78 ±0.10 (8 ±1)	Min. 0.20 (2.0)
NCU PCB	Taptite, cup S M3x6	1	0.78 ±0.10 (8 ±1)	Min. 0.20 (2.0)
Power supply PCB	Taptite, cup S M3x6	2	0.78 ±0.10 (8 ±1)	Min. 0.20 (2.0)
Grounding terminal of AC cord	Screw, pan (w/ washer) M4x8DB	1	0.59 ±0.10 (6 ±1)	Min. 0.20 (2.0)
Harness supporter	Taptite, cup B M3x8	1	0.78 ±0.10 (8 ±1)	Min. 0.20 (2.0)
	Taptite, cup S M3x6	1	0.78 ±0.10 (8 ±1)	Min. 0.20 (2.0)
Main chassis	Taptite, cup B M4x12	4	0.98 ±0.10 (10 ±1)	Min. 0.29 (3.0)
Purge unit	Taptite, cup S M3x6	1	0.78 ±0.10 (8 ±1)	Min. 0.20 (2.0)
	Taptite, cup B M3x10	1	0.78 ±0.10 (8 ±1)	Min. 0.20 (2.0)
Platen	Taptite, cup S M3x5	3	0.78 ±0.10 (8 ±1)	Min. 0.20 (2.0)
Idle pulley stopper	Screw, pan (s/p washer) M3x6DB	1	0.69 ±0.10 (7 ±1)	Min. 0.20 (2.0)
	Taptite, cup S M3x6	1	0.78 ±0.10 (8 ±1)	Min. 0.20 (2.0)
Carriage motor	Screw, pan (s/p washer) M3x6DB	2	0.69 ±0.10 (7 ±1)	Min. 0.20 (2.0)

Location	Screw type	Q'ty	Tightening torque N•m (kgf•cm)	Loosening torque N•m (kgf•cm)
Eccentric bushings R and L	Screw, pan (s/p washer) M3x6DB	2	0.69 ±0.10 (7 ±1)	Min. 0.20 (2.0)
Tension plate	Screw, pan (s/p washer) M3x6DB	1	0.69 ±0.10 (7 ±1)	Min. 0.20 (2.0)
Paper feed motor	Screw, pan (s/p washer) M3x6DA	2	0.69 ±0.10 (7 ±1)	Min. 0.20 (2.0)

■ Preparation

Prior to proceeding to the disassembly procedure,

(1) Unplug

- the modular jack of the telephone line,
- the modular jack of the curled cord (and remove the handset),
- the PC interface cable (not shown below), and
- the modular jack of an external telephone set if connected (not shown below).

(2) Remove

- the document support,
- the paper wire extension,
- the document wire extension, and
- the paper tray.

NOTE: Do not remove the ink cartridges when disassembling the equipment except when removing the print heads.

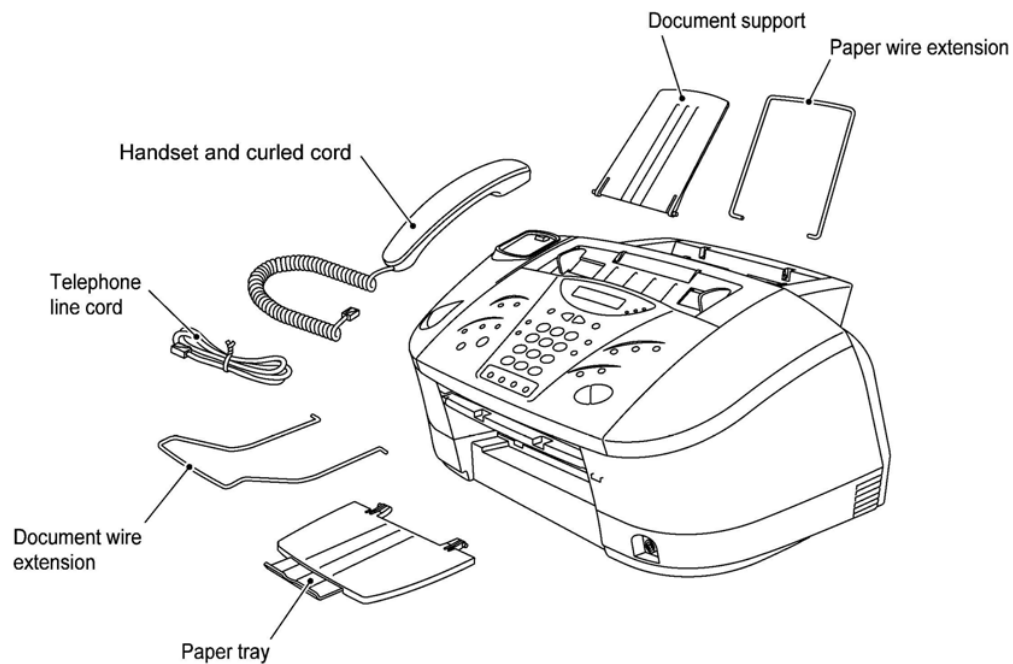

■ How to Access the Object Component

- On the next page is a disassembly order flow which helps you access the object components. To remove the paper feed motor, for example, first find it on the flow and learn its number (1.25 in this case). You need to remove parts numbered 1.7 to 1.9, 1.11 to 1.16, 1.23 and 1.24 so as to access the paper feed motor.
- Unless otherwise specified, the disassembled parts or components should be reassembled in the reverse order of removal.

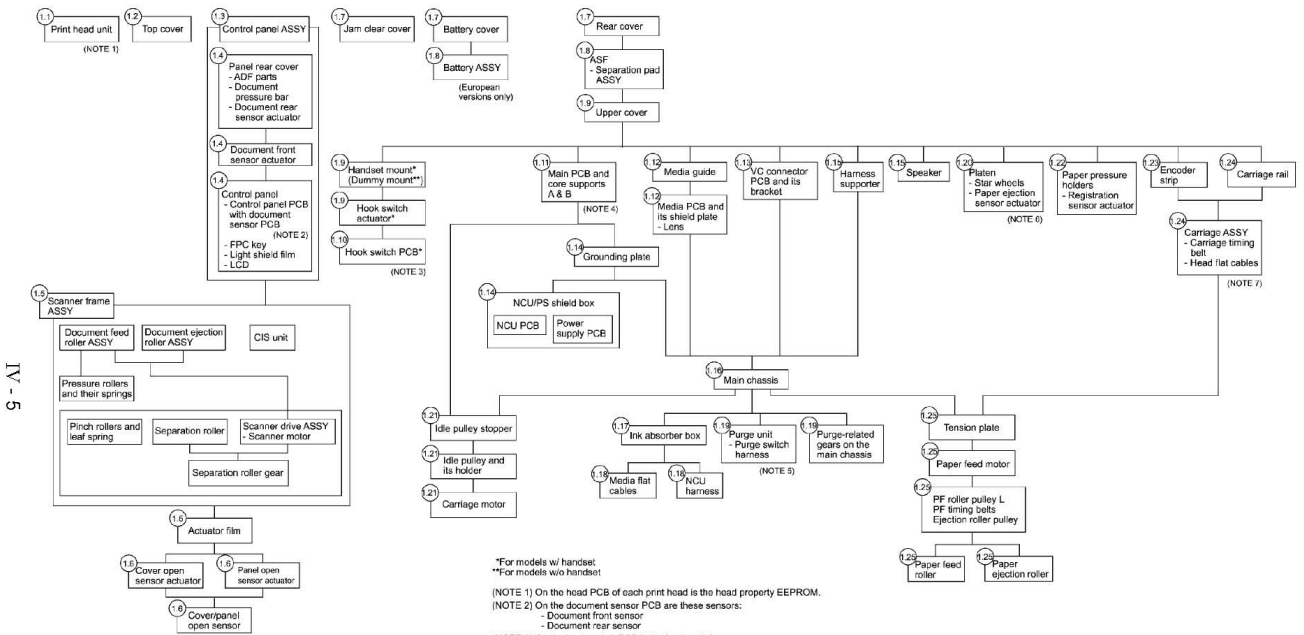

*For models w/ handset
 **For models w/o handset

(NOTE 1) On the head PCB of each print head is the head property EEPROM.
 (NOTE 2) On the document sensor PCB are these sensors:
 - Document front sensor
 - Document rear sensor

(NOTE 3) On the hook switch PCB is the hook switch.

(NOTE 4) On the main PCB is the registration sensor.

(NOTE 5) On the purge unit are these switches:
 - Purge cam HP switch
 - Purge switching cam HP switch

(NOTE 6) On the platen is the paper ejection sensor.

(NOTE 7) On the carriage PCB are these sensors:
 - Carriage encoder
 - Ink cartridge sensors
 - Black ink empty sensor
 - Heat transducer

1.1 Print Head Unit

During disassembly jobs (except when removing the carriage rail or carriage ASSY), the print head unit and all the four ink cartridges should be kept in place.

NOTE: The print head unit is a pair of the right and left print heads. If either one of them is defective, replace the pair with a new one.

NOTE: To replace the print head unit with a new one, you need to move the carriage to the ink replacement position by placing the machine in the ink replacement mode. Do not move the carriage by hand when the power is off. If the print head is replaced with a new one not in the ink replacement mode, you need to adjust the sensing reference level of the black ink empty sensor (see Chapter V, Section 3.12).

NOTE: If you replace both the print head unit and main PCB with new ones at the same time, you need to adjust the sensing reference level of the black ink empty sensor (see Chapter V, Section 3.12).

NOTE: If you replace the print head unit with a new one, replace also the ink absorber box and ink cartridges with new ones.

- (1) Plug the power cord into a wall socket.
- (2) Press the **Ink Management** key to place the machine in the ink replacement mode.
- (3) Press ◀ or ▶ key to choose "2. REPLACE INK," then press **Set** key.
The carriage automatically moves to the ink replacement position.
- (4) Open the control panel ASSY and top cover.
- (5) Remove all ink cartridges, one at a time. (Refer to the OWNER'S MANUAL.) Or, remove the yellow shipping cover.
- (6) Unplug the power cord from the wall socket.
- (7) Push the pawl and pull up the ink cartridge guide in the direction of the arrows ① and ②.

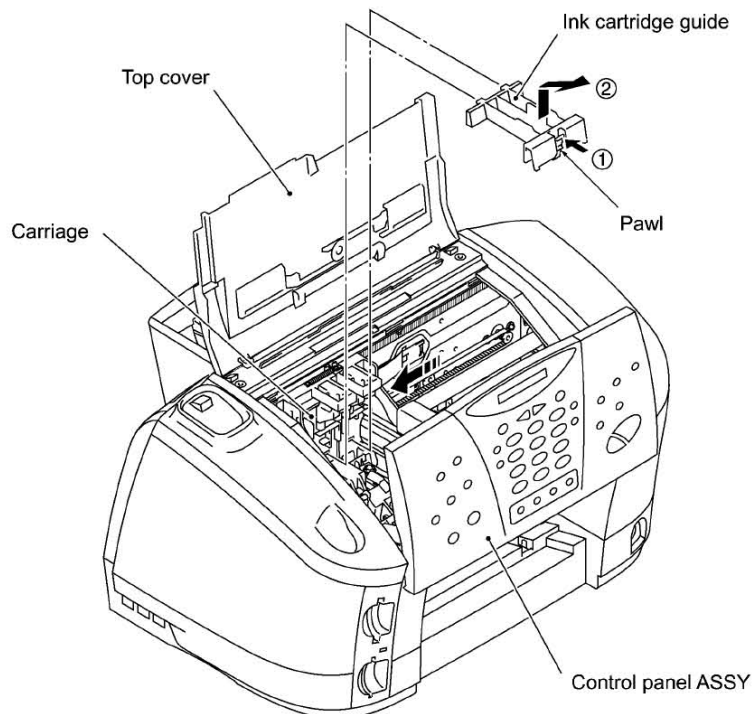

- (8) Remove the head driver clamps R and L in the direction of arrows ① and ②.

NOTE: When you pull the clamps towards you, they may interfere with the scanner frame. Put each of the clamps within the cutout provided in the scanner frame by moving the carriage each time.

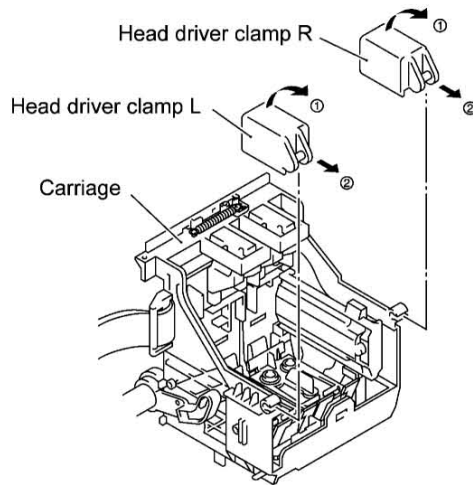

- (9) Press each of the print heads R and L to the rear (against the leaf spring) to release the front tab from the carriage, then lift it up and out of the carriage.

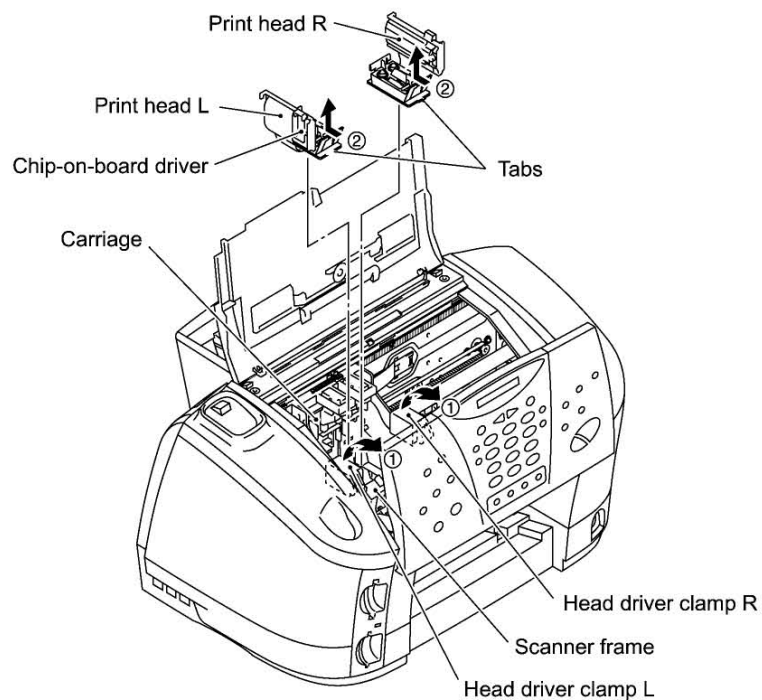

NOTE: Do not touch the printing ends (nozzles) of the print heads; doing so will stain your hands with ink.

NOTE: Be sure to put a head nozzle seal and filter seal on each of the print heads as shown on the next page. Leaving the print heads without those seals will dry up their printing ends and filters, resulting in damaged heads.

NOTE: Do not touch the chip-on-board (COB) driver of each print head.

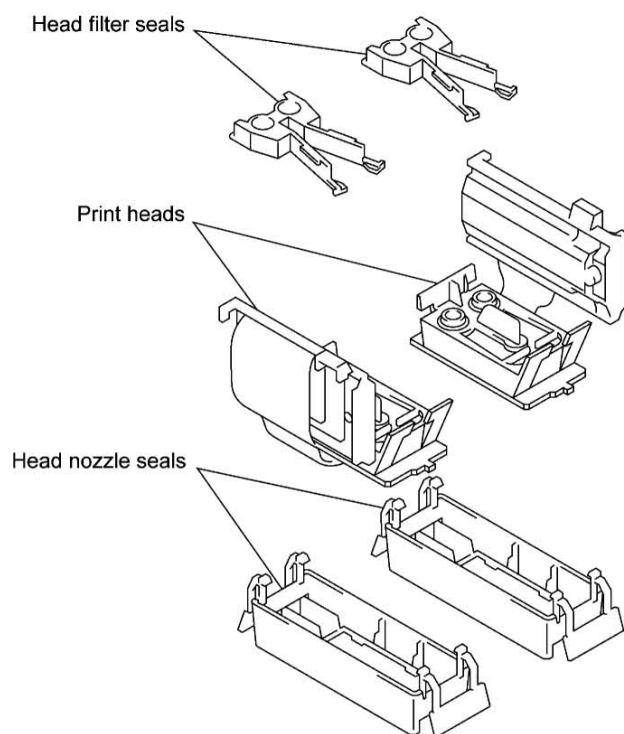

- (10) If the head caps have collected ink, clean them with a head cleaner. If the surrounding parts are stained with ink, wipe them off with a clean cloth.
- (11) To install a new (or removed) print head unit, take off the head nozzle seals and then set each print head according to the following steps as shown on the next page:
 - 1) Put the print head into the carriage in the direction of arrow ①.
 - 2) Insert the front tab of the print head into the cutout provided in the carriage in the direction of arrow ②.
 - 3) Push down the rear end of the print head into place along the leaf spring in the direction of arrow ③.
 - 4) Fit the head driver of the print head over the two positioning pins of the carriage in the direction of arrow ④.
 - 5) Lock the head driver with the head driver clamp in the direction of arrow ⑤.
 - 6) Remove the head filter seals.

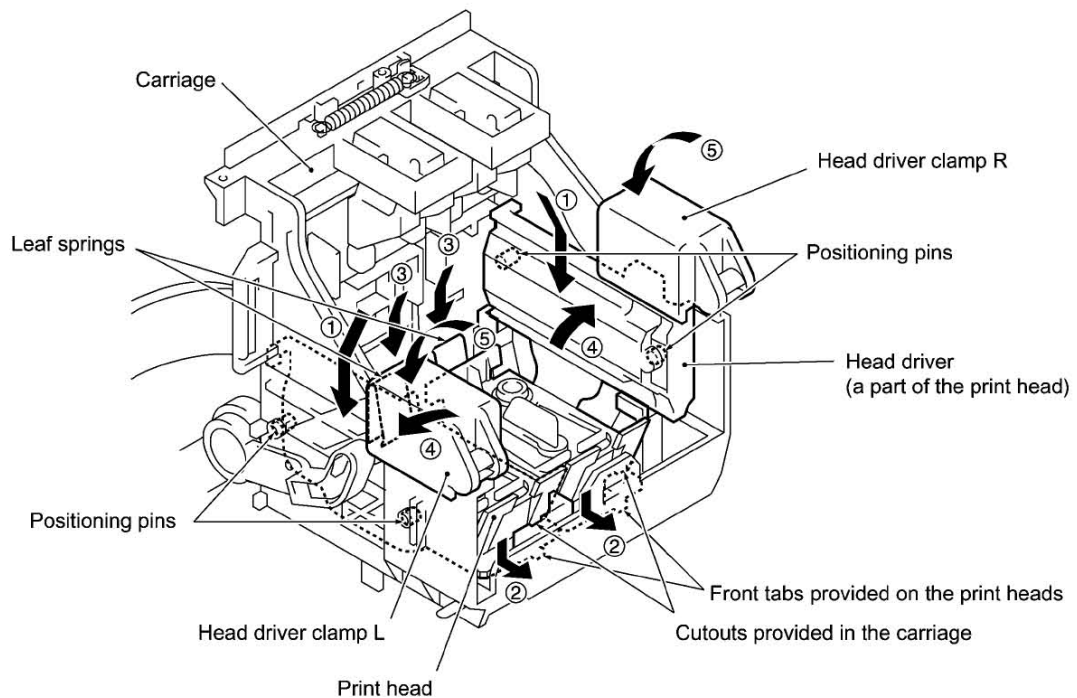

- (12) Close the top cover and control panel ASSY, then plug the power cord into a wall socket. The following messages will appear alternately on the LCD.

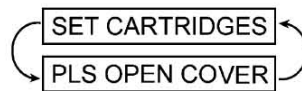

- (13) Open the control panel ASSY and the top cover. After a few seconds, the carriage will move left to the ink replacement position.

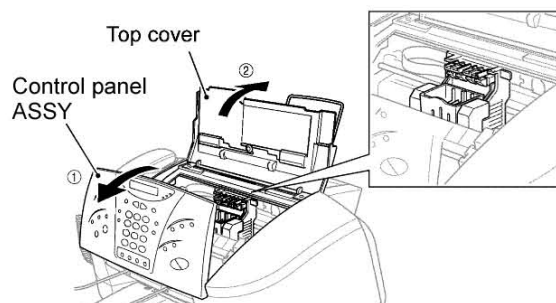

- (14) Set new ink cartridges from left to right in the order of black, yellow, cyan, and magenta, as shown on the next page.

NOTE: Each color has its own correct position. Match the markings of the color indicators on the cartridge holder as a guide.

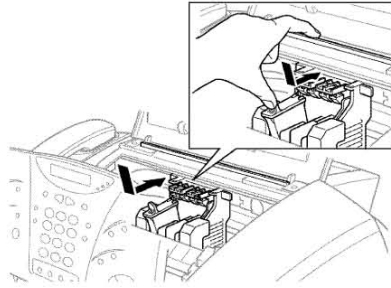

- (15) Close the top cover and control panel ASSY.
- (16) Follow the instructions shown on the LCD.
NOTE: Make sure that paper is loaded in the ASF.
NOTE: The machine enters a "head cleaning" cycle that takes approx. 6 minutes.
- (17) If the machine prints no Test Sheet, press the **Function** (or **Menu**) key, select "2. PRINTER", press the **Set** key, select "1: TEST PRINT," and press the **Start** key.
This procedure will print a Test Sheet.
- (18) Check the print quality of the Test Sheet. If it is not good, clean the print head again by pressing the **2** key. The screen will ask you if the print quality is OK for each color.
- (19) Adjust the alignment of vertical print lines, referring to Chapter V, Subsection 3.14.

1.2 Top Cover

- (1) Open the top cover.
- (2) Pull the right or left rear end of the top cover outwards to release it from the boss provided on the upper cover.

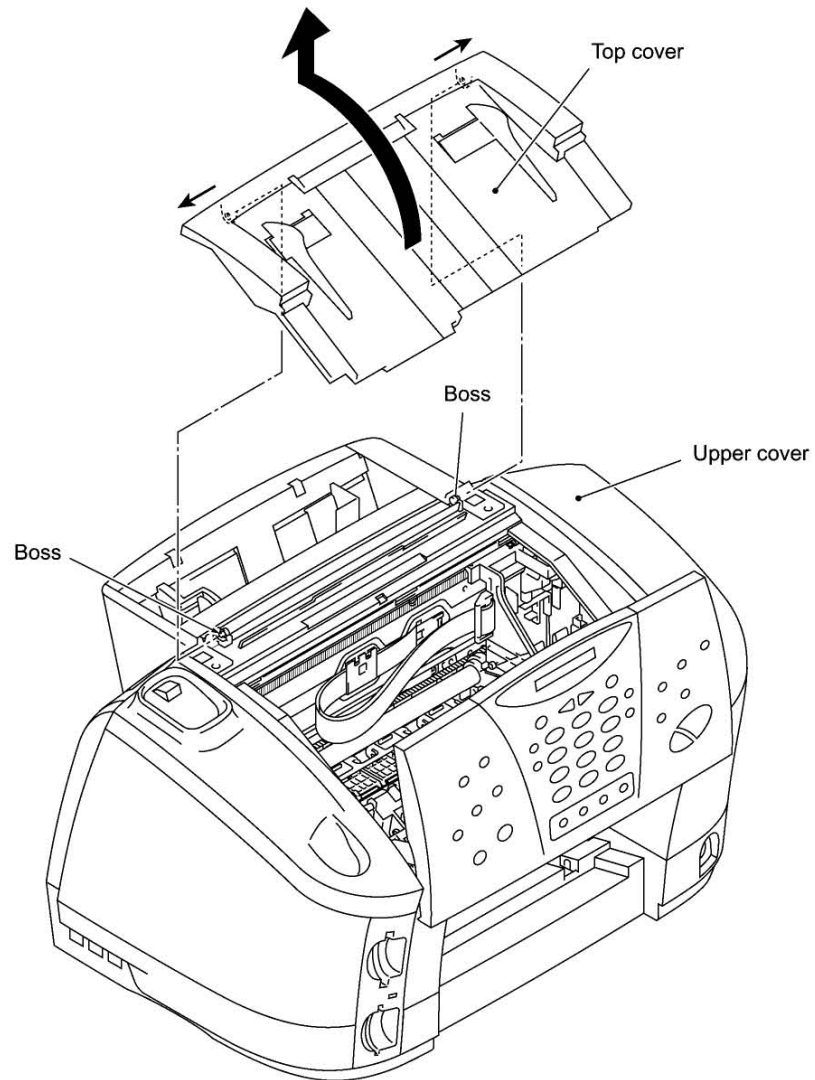

1.3 Control Panel ASSY

- (1) Open the control panel ASSY.
- (2) Push the right and left arms of the control panel ASSY outwards (in the direction of arrow ②) to release those arms from bosses "X" provided on the scanner frame ASSY with a flat screwdriver.
- (3) Open the control panel ASSY further, then disconnect the panel-main harness from the control panel PCB and take it out of the harness guides.

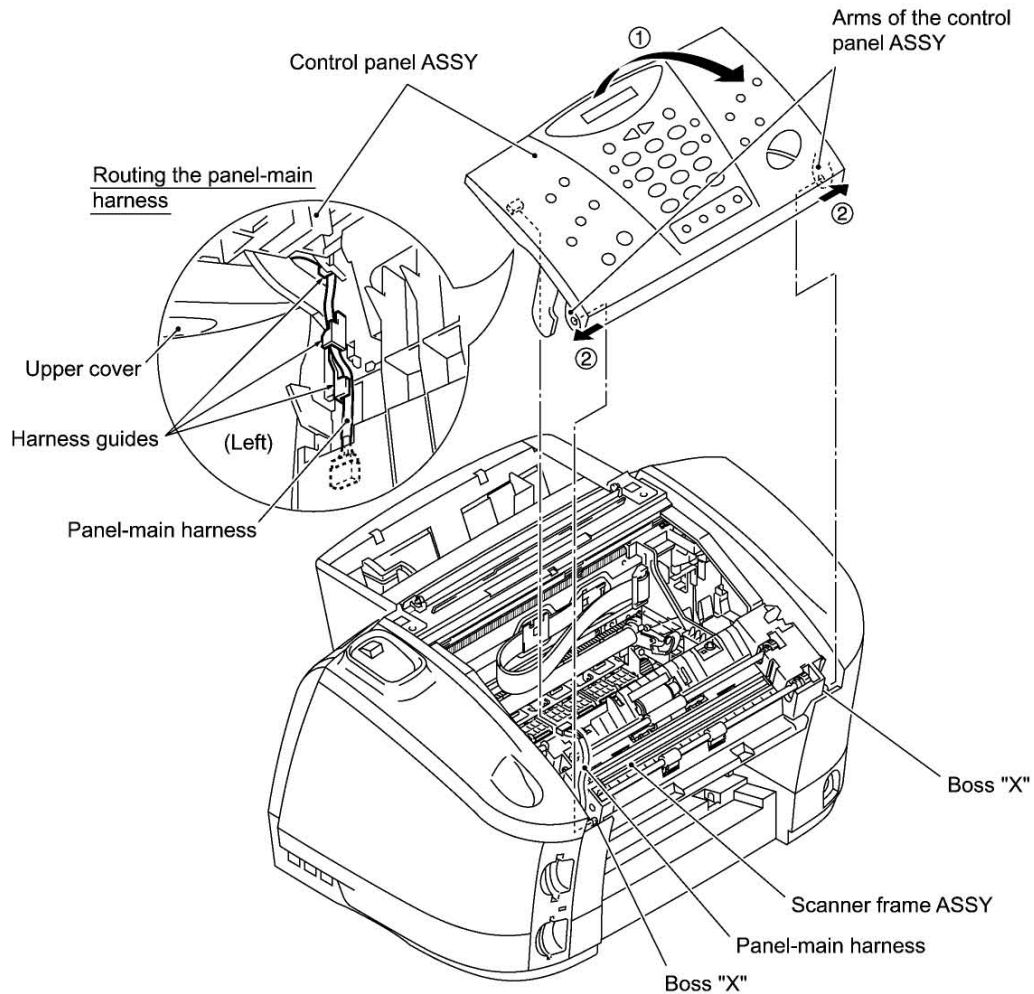

■ Reassembling Notes

- Route the panel-main harness along the three harness guides as illustrated above.

1.4 Panel Rear Cover and Control Panel

- (1) Place the control panel ASSY upside down.

If you do not need to remove the ADF parts, antistatic brush, document pressure bar, or document rear sensor actuator, skip to step (6)

- (2) To remove the ADF parts (spring plates, ADF guide caps, and separation rubber), remove the screw.
- (3) To replace the antistatic brush, remove it.

NOTE: Once removed, it will become unusable and a new part will have to be put back in.

- (4) To remove the document pressure bar, first release the center tab from the panel rear cover and then push supports "a" inwards with your fingers. The spring also comes off.
- (5) To remove the document rear sensor actuator, pull either of supports "b" on the panel rear cover outwards.

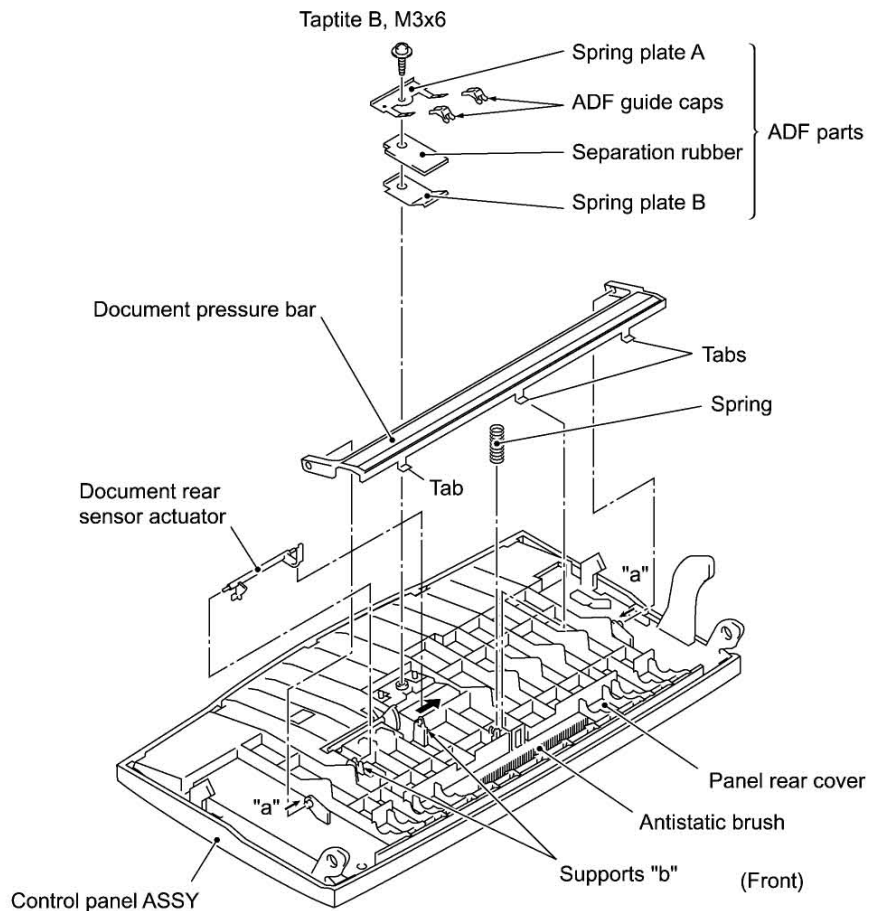

- (6) Remove the two screws from the panel rear cover.
- (7) Unhook the panel rear cover from eight "X" latches provided on the control panel and lift up the panel rear cover.
- (8) Fully turn the document front sensor actuator to the rear and lift it up.
- (9) Unhook the document sensor PCB from two "Y" latches.
- (10) Unhook the control panel PCB from two "Z" latches.
- (11) Slightly lift up the control panel PCB, then unlock the LCD cable connector and disconnect the LDC flat cable. Next, unlock the FPC key connector and disconnect the FPC key.

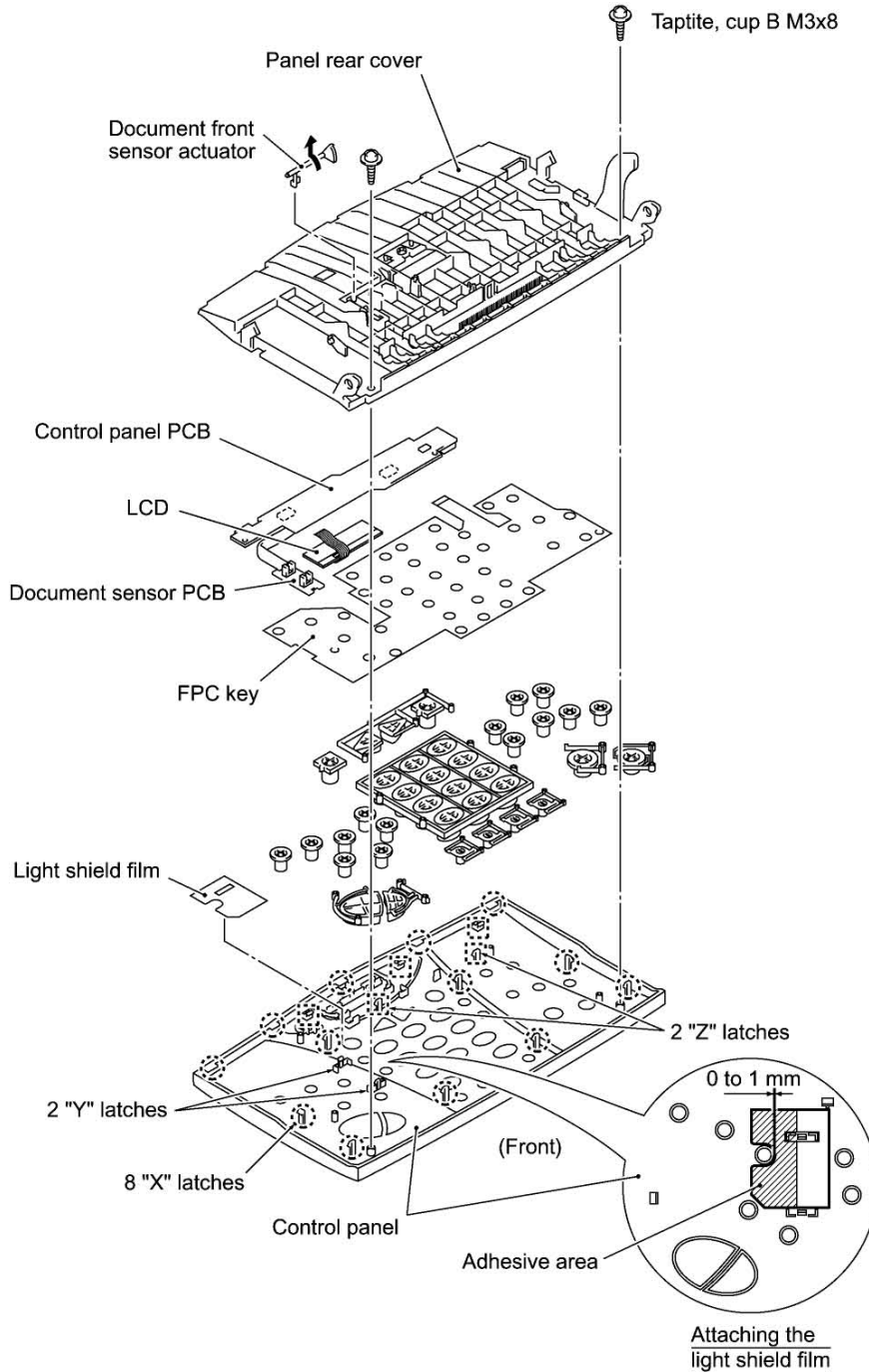

(12) As shown below, pull the locking arms outwards and take out the LCD while pulling the LCD flat cable gently.

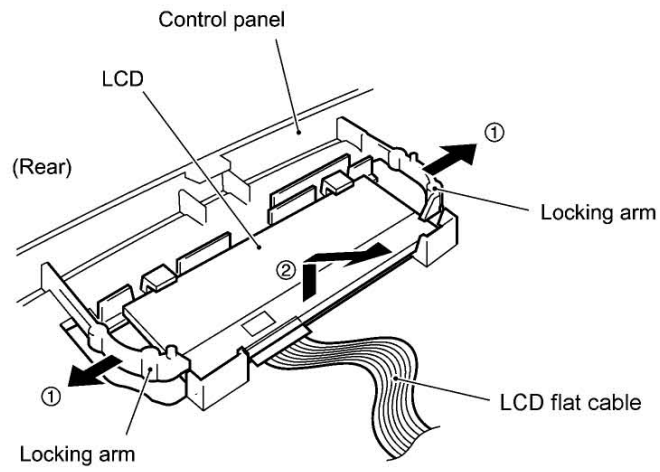

■ Reassembling Notes

- Before reinstalling the LCD to the control panel, wipe fingerprints or dust off the LCD surface and control panel window with a soft cloth.
- A new LCD is covered with a protection sheet. Before installing it, remove the protection sheet.

1.5 Scanner Frame ASSY (Document feed roller ASSY, document ejection roller ASSY, CIS unit, actuator film, pinch rollers, separation roller, and scanner drive ASSY)

You may remove the following parts from the top of the scanner frame ASSY without taking out the ASSY from the upper cover.

- Document feed roller ASSY and pressure rollers
- Document ejection roller ASSY
- CIS unit

If you do not need to remove the above parts, skip to step (5) in the following procedure.

- (1) Lightly push arm rib "a" to the rear, then shift the document feed roller ASSY to the right and upwards.
- (2) Push the two latches to the rear and remove the pressure rollers, their shaft, and springs.
- (3) Lightly push arm rib "b" to the rear, then shift the document ejection roller ASSY to the right and upwards.

NOTE: Take care not to break the arm ribs. They may easily break.

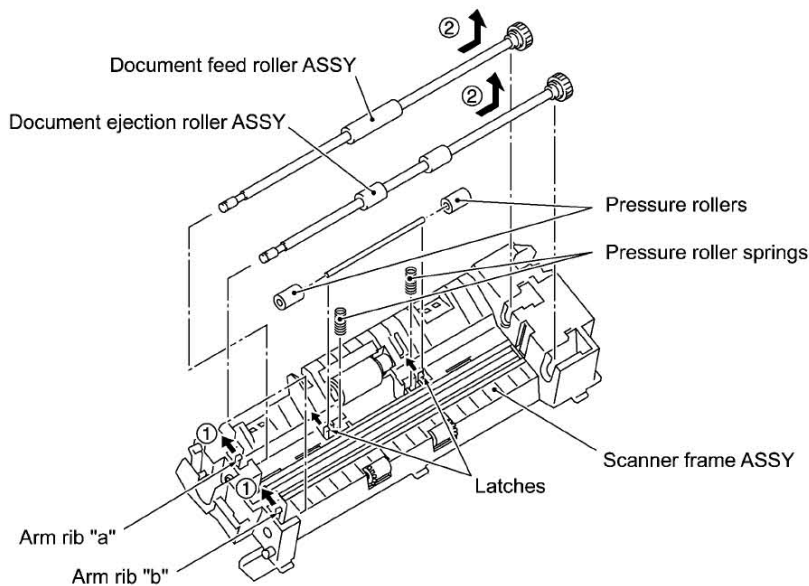

- (4) Lightly pull up the arm, move the CIS unit to the left, and lift up the right edge of the CIS unit. While holding up the CIS unit, disconnect the CIS harness. The CIS springs also come off.

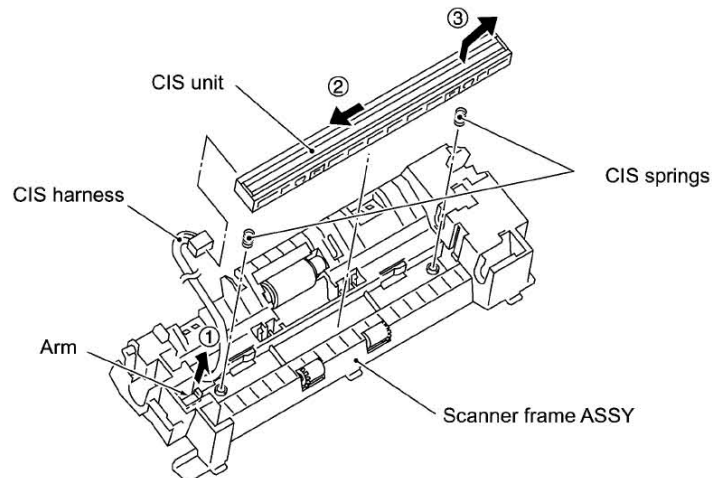

- (5) Remove the two screws from the scanner frame ASSY.
- (6) Lightly lift up the rear edge of the scanner frame ASSY to release the three front tabs, hold up the ASSY, and disconnect the scanner motor harness (and the CIS harness if the CIS unit is mounted).
- (7) Remove the actuator film.

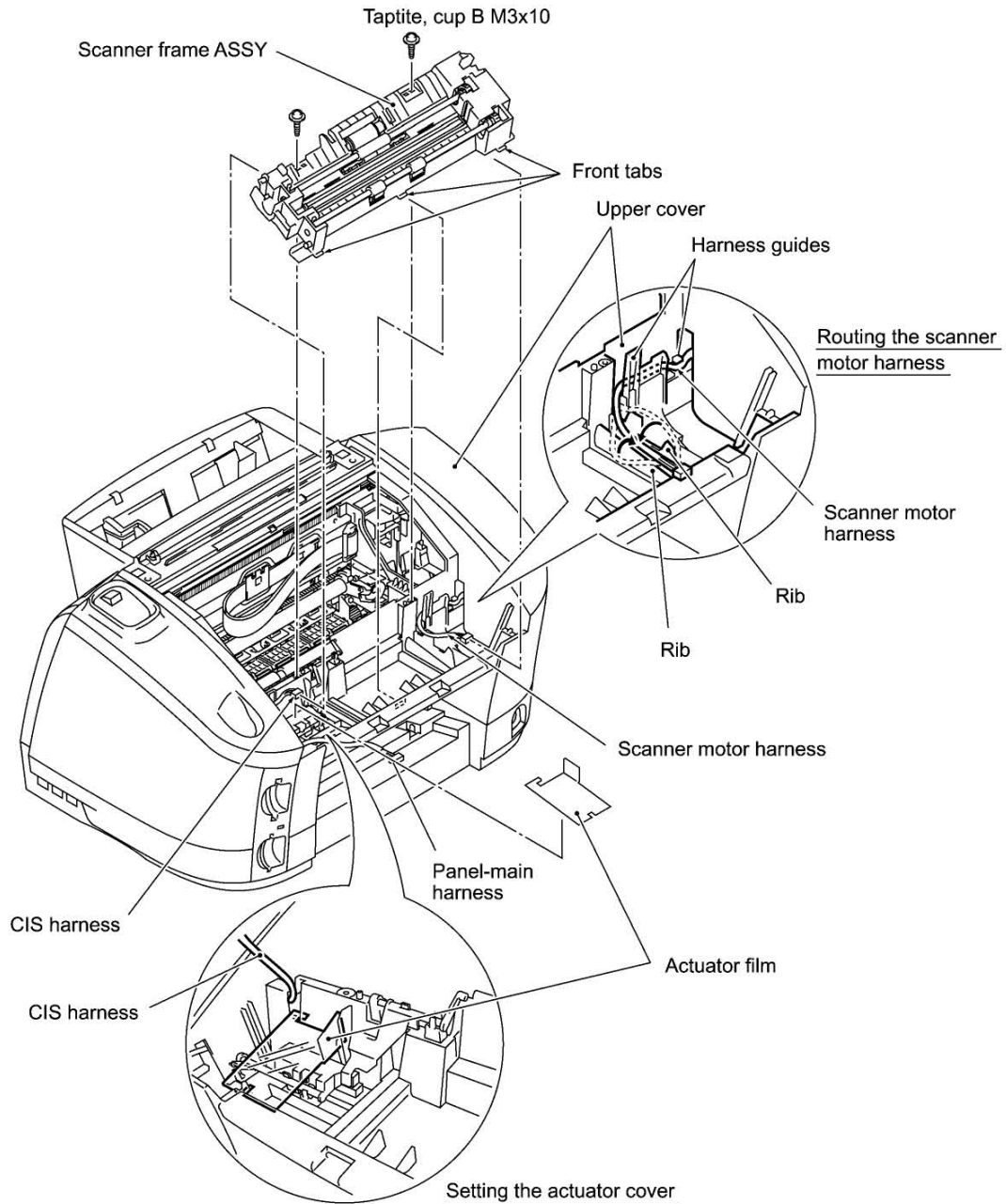

- (8) Remove the screw from the pinch roller leaf spring, then remove the pinch rollers and their shaft.

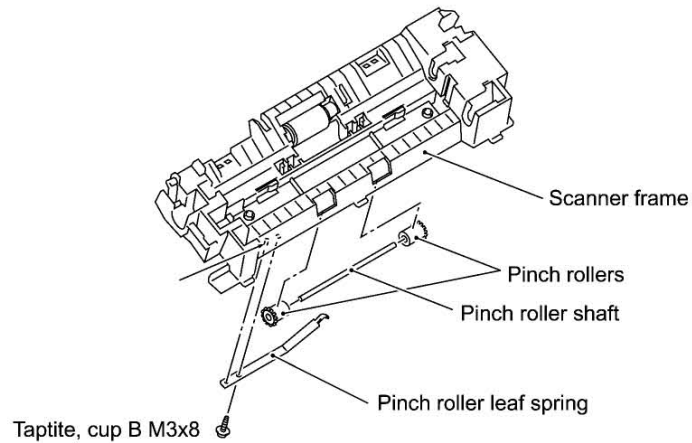

- (9) Press the arm and shift the separation roller gear to the right (in the direction of arrows ① and ②). Remove the separation roller (arrow ③).
- (10) Remove the two screws and take off the scanner drive ASSY together with the separation roller gear.
- (11) Remove the screw to release the scanner motor.

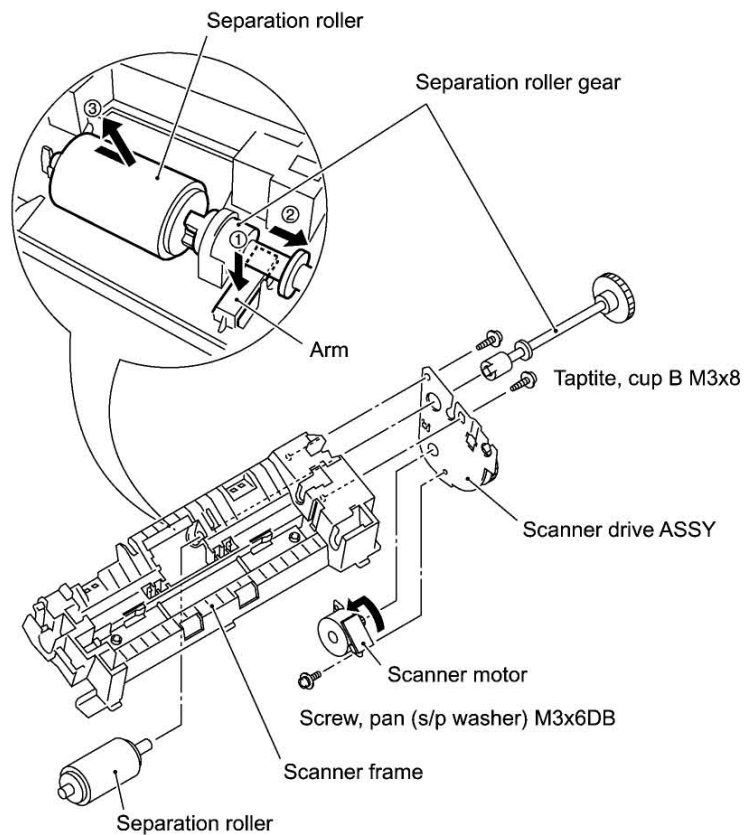

■ Reassembling Notes

- Be sure to route the scanner motor harness along the harness guides and pass between the two ribs as illustrated on the previous page.

1.6 Cover Open Sensor Actuator, Panel Open Sensor Actuator, and Their Sensor

- (1) Make sure that the actuator film has been removed (see page IV-17).
- (2) Push arm "a" to the rear and remove the cover open sensor actuator in the direction of arrows ① and ②.
- (3) Push arm "b" to the rear and remove the panel open sensor actuator in the direction of arrows ① and ②.
- (4) Disconnect the open sensor harness and remove the cover/panel open sensor from the upper cover.

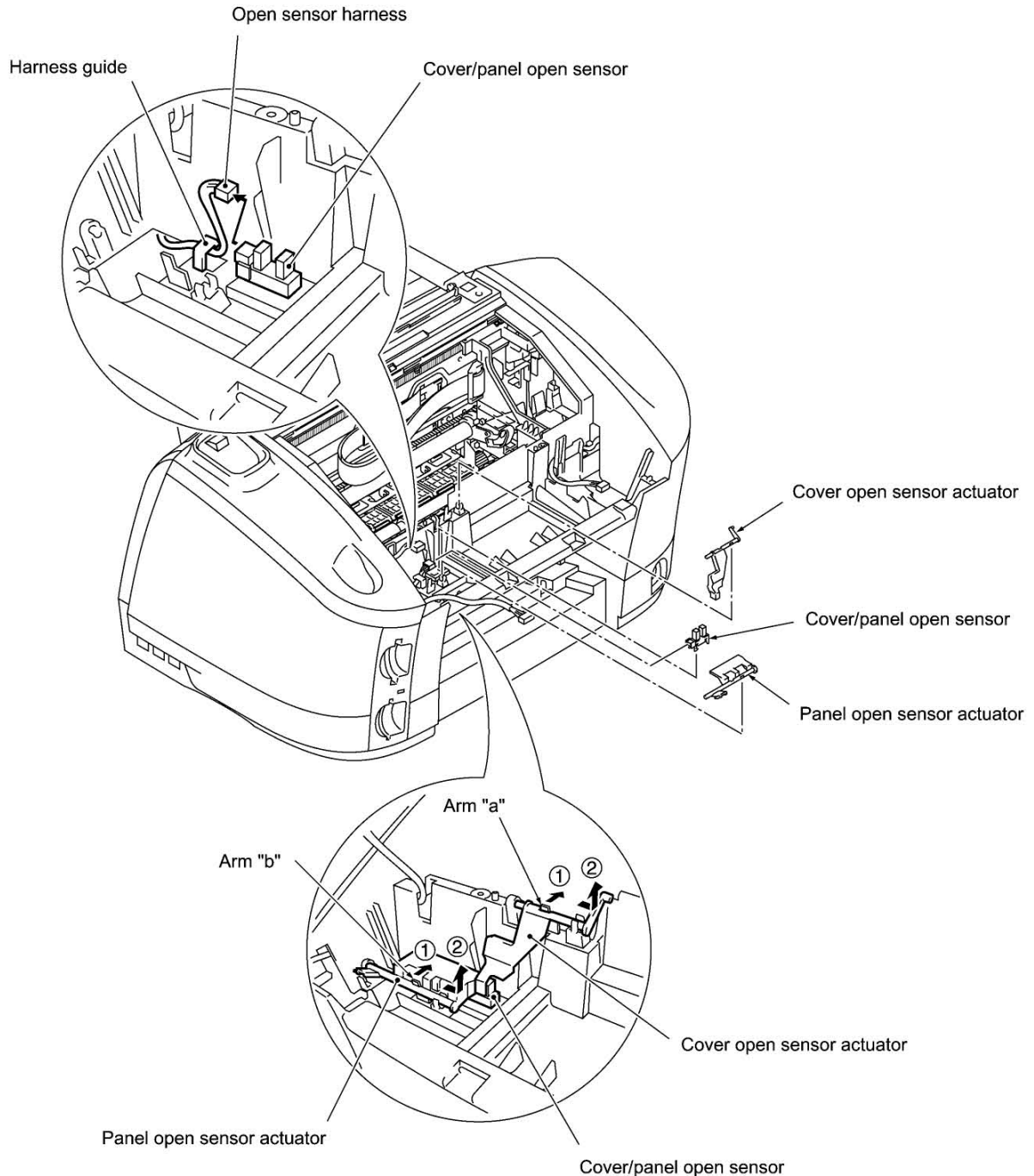

1.7 Jam Clear Cover, Battery Cover, and Rear Cover

- (1) Open the jam clear cover and lightly warp it to release from the bosses.
- (2) Insert the tip of a flat screwdriver into the square hole at the bottom of the battery cover and twist it to release the latch.

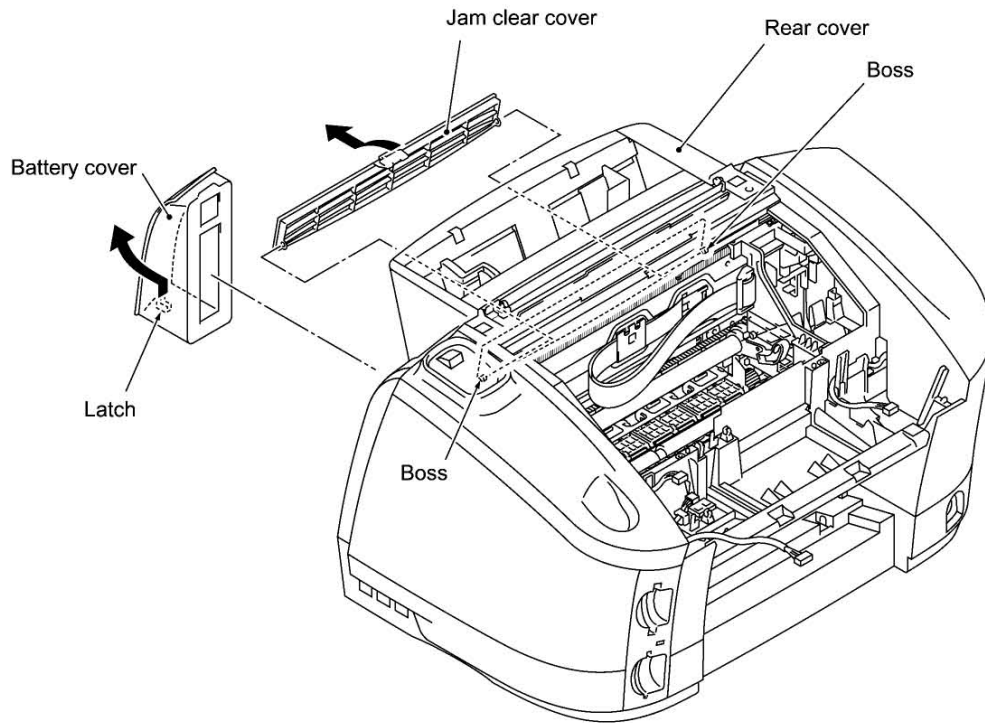

- (3) Remove the two screws from the rear cover.
- (4) Pull up sections "c" to release the rear cover from the hooks. Then push the rear cover retainers through the holes (to which the jam clear cover is to be set) to release the three locks from the rear cover retainers.

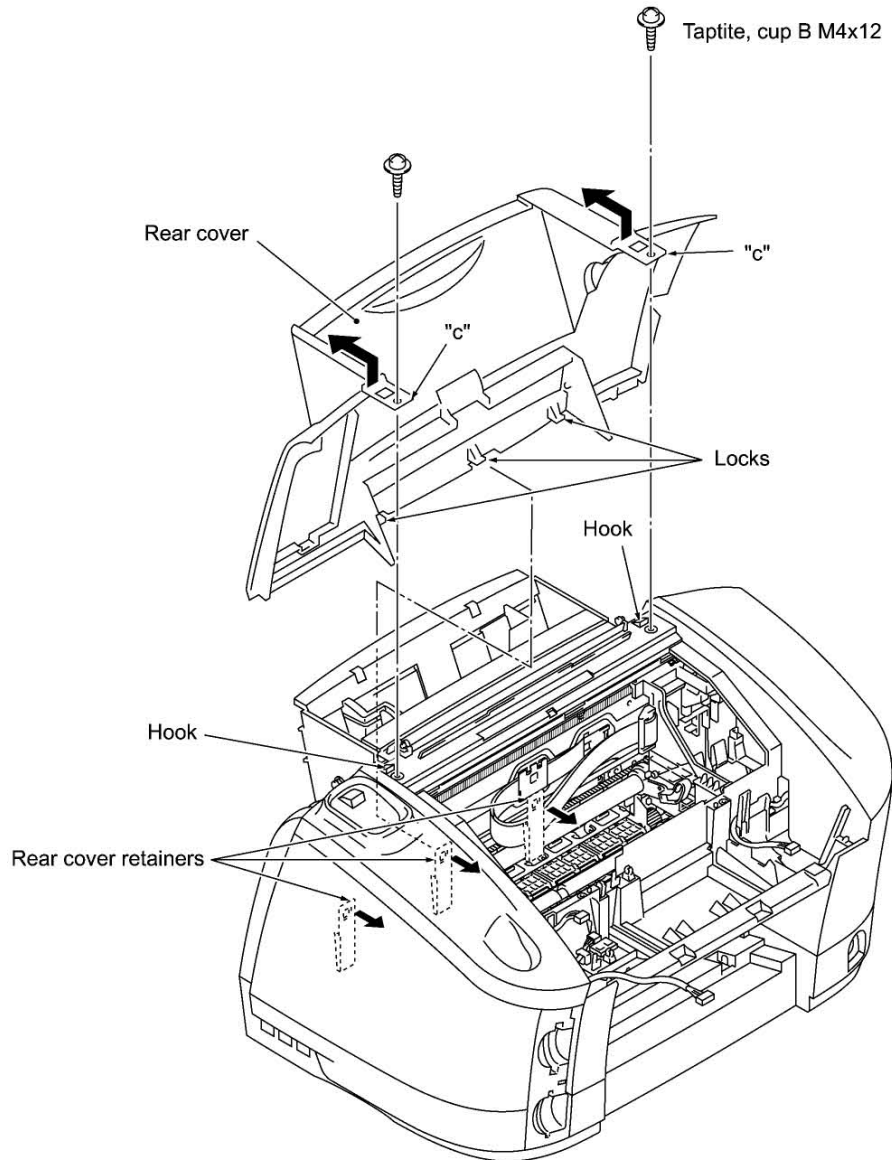

1.8 Battery ASSY* and Auto Sheet Feeder (ASF)

(*Provided on the European models)

- (1) European models: To replace the battery ASSY (Ni-MH battery), plug the power cord of the machine into a power outlet, disconnect the battery harness from the main PCB, and take out the battery ASSY. Set a new battery ASSY, connect the battery harness to the main PCB, and then unplug the power cord.

Disconnecting the battery harness with the power cord unplugged will lose the settings (e.g., calendar clock and received FAX data) stored in the RAM.

If you do not need to replace the battery ASSY but you will remove the main PCB in the following procedures, take out the battery ASSY from the ASF and put it on the main PCB with the battery harness being connected.

- (2) Remove the three screws from the ASF.
- (3) Press sections "d" inwards to release the ADF from the main chassis. At the right side (when viewed from the rear), take out the paper feed motor harness from the harness guide on the ADF and remove the ADF to the rear.

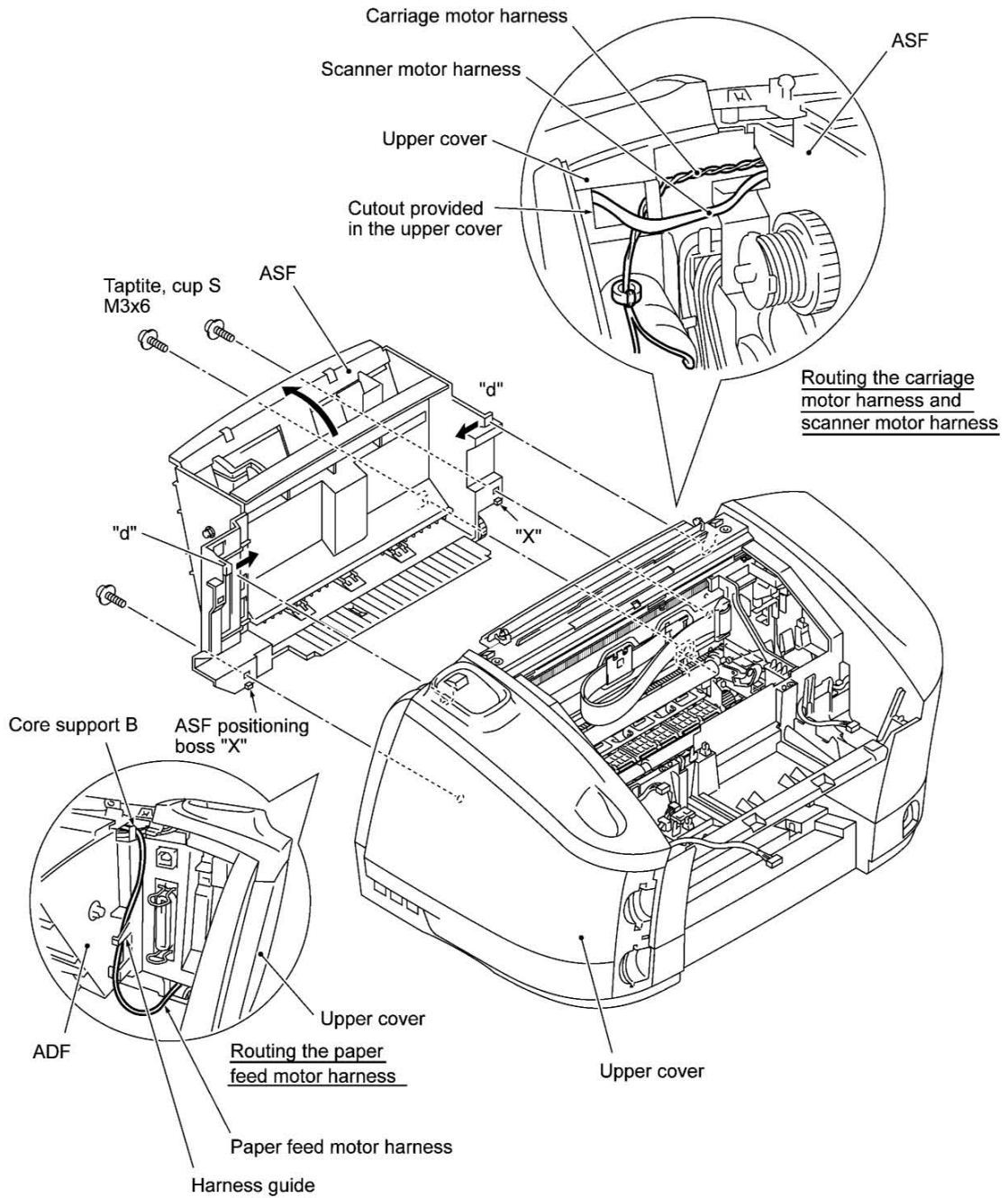

(4) Pull out the separation pad ASSY.

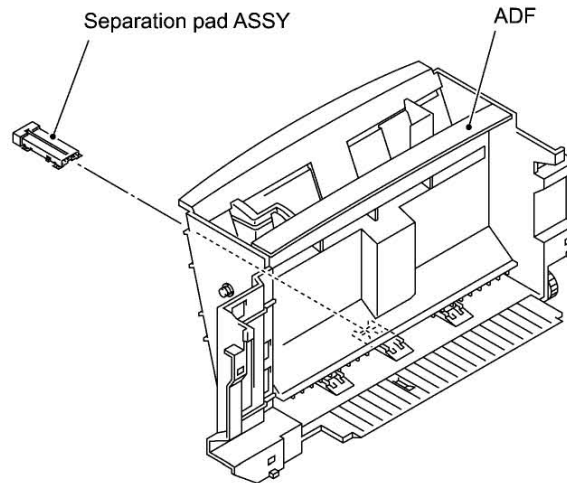

(5) Disassemble the separation pad ASSY as shown below.

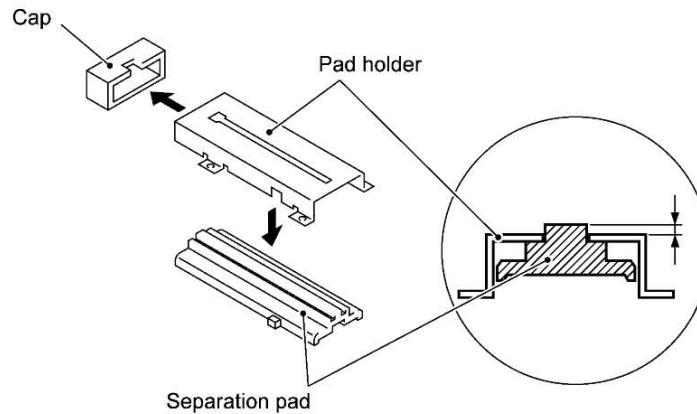

■ Reassembling Notes

- When assembled, the separation pad should be protruded from the pad holder as shown above.
- When setting the ADF back into place, be sure to fit the two ADF positioning bosses "X" (shown on the previous page) into the positioning square holes provided in the main chassis.

1.9 Upper Cover, Handset Mount*¹, Dummy Mount*², and Hook Switch Actuator*¹

(*¹For models w/ handset, *²For models w/o handset)

- (1) Take out the paper feed motor harness from the hook provided on the upper cover.
- (2) Disconnect the following harnesses from the main PCB:
 - Scanner motor harness
 - Carriage motor harness (Pull it out through the cutout provided in the upper cover. See the illustration shown on page IV-23.)
 - Cover/panel open sensor harness
 - Panel-main harness
 - CIS harness

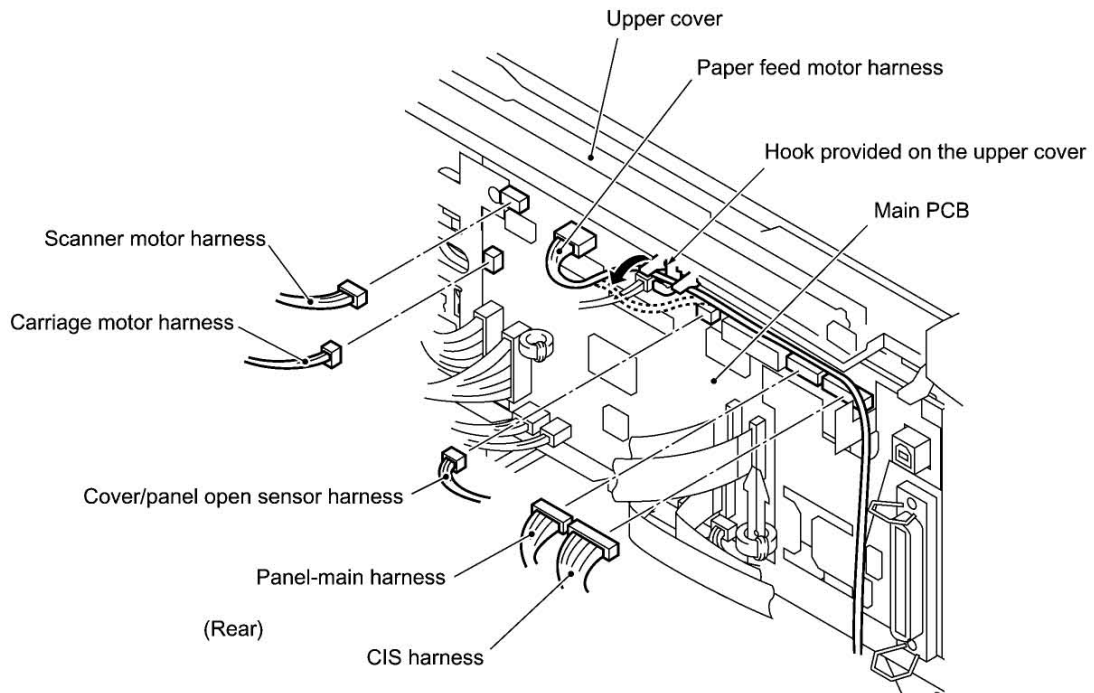

- (3) Remove the two screws from the upper cover. (See the next page.)

- (4) Press the four cover retainers of the bottom cover inwards to release the hooks of the upper cover, then lift up the upper cover.

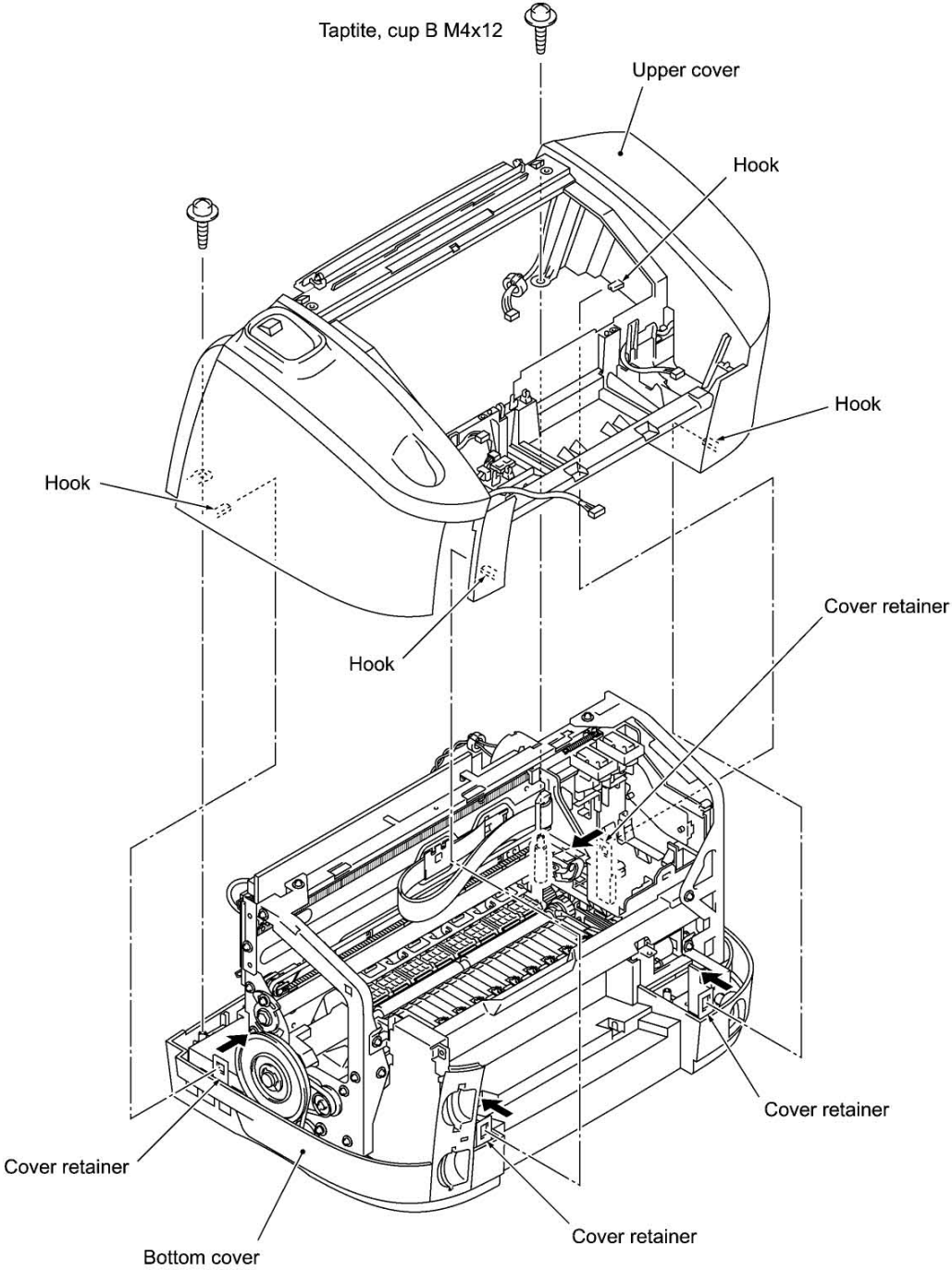

- (5) Pull the latches provided on the upper cover outwards (in the direction of arrow ①) while twisting the handset mount*¹ or dummy mount*² so that it tilts over to the right (arrow ②).
- (6) Remove the hook switch actuator*¹ and its spring*¹.

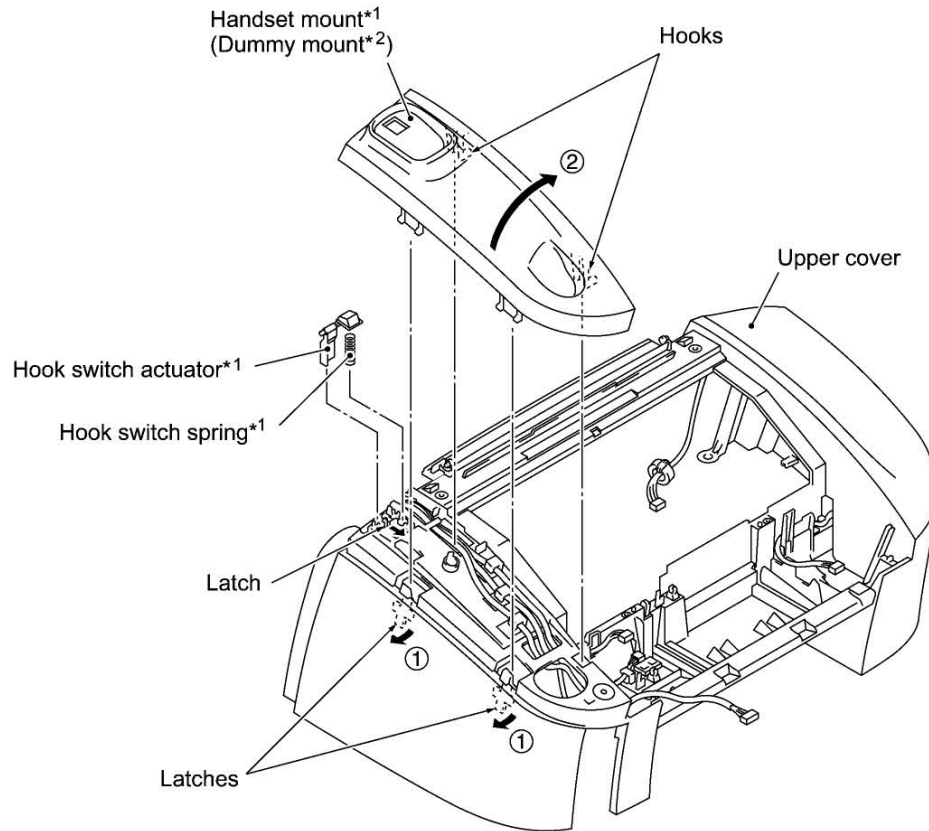

*¹ For models w/ handset
*² For models w/o handset

■ Reassembling Notes

- Before setting the upper cover back into place, make sure that the harnesses are routed as shown below.

At the left side

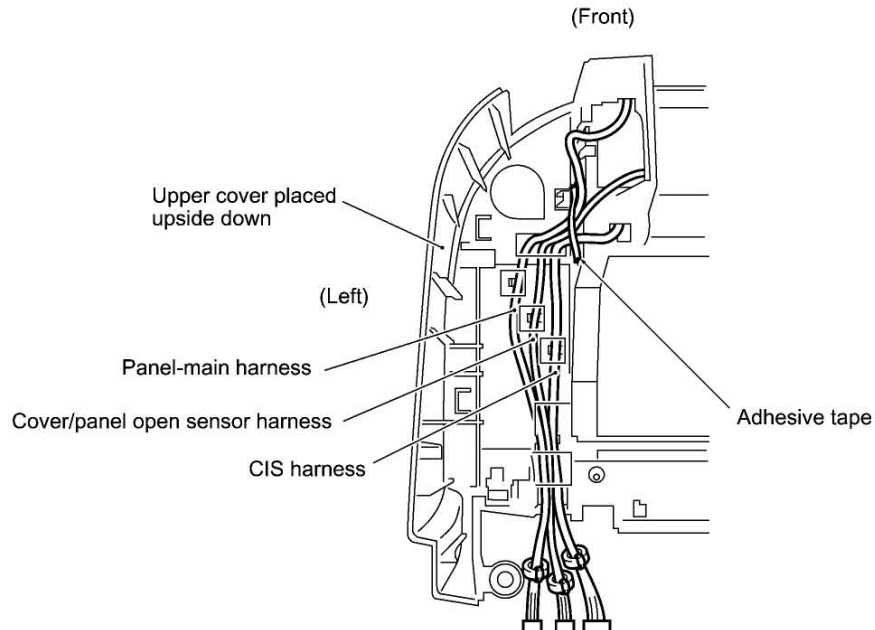

At the right side

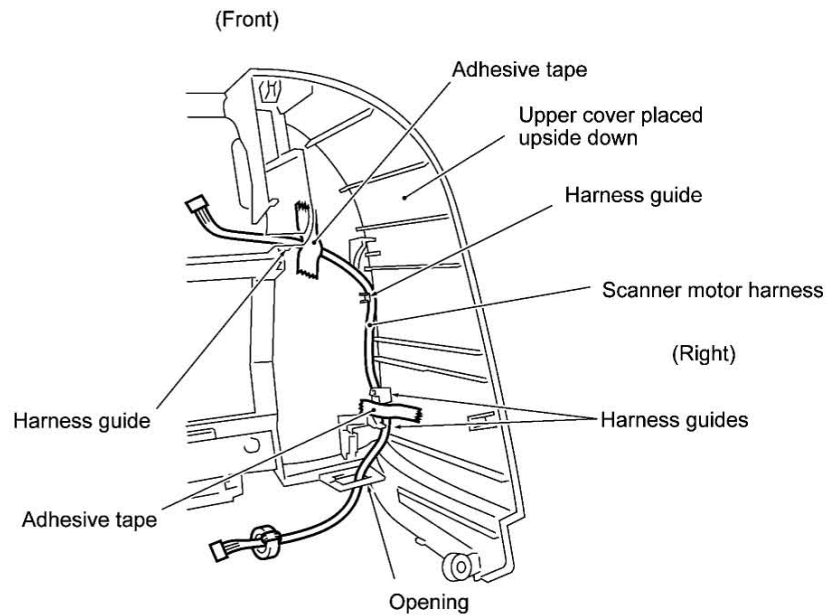

1.10 Hook Switch PCB*

(*Not provided on models w/o handset)

- (1) Disconnect the hook switch harness from the hook switch PCB.
- (2) Remove the screw from the hook switch PCB.
- (3) Remove the screw from the PCB support.

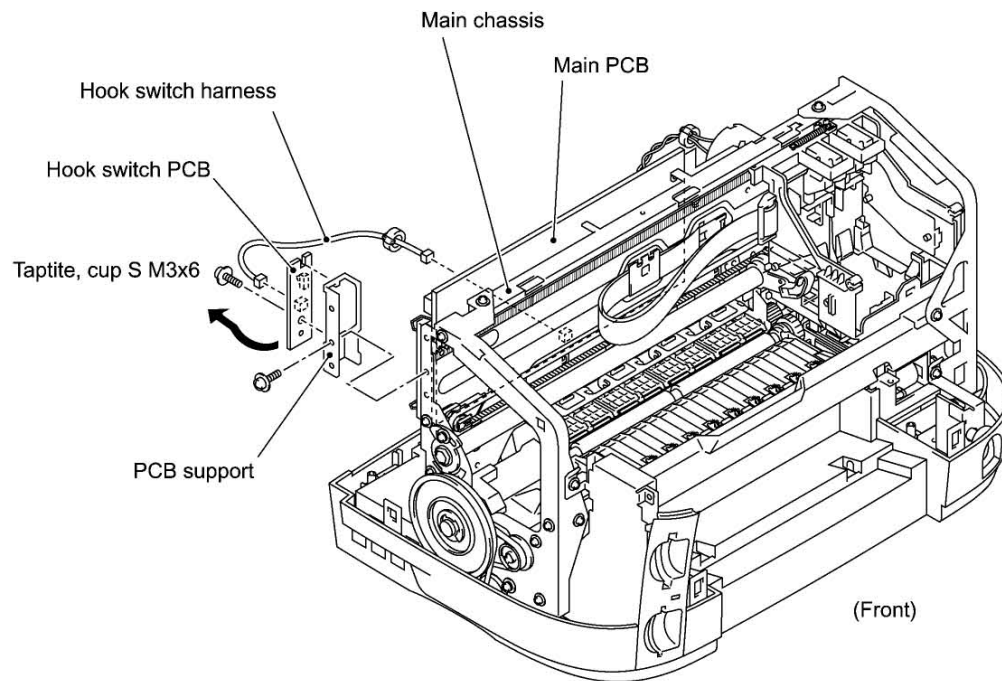

1.11 Main PCB and Core Supports

- (1) Disconnect the following harnesses from the main PCB:
- VC harness
 - Paper feed motor harness
 - Head flat cables 1 and 2
 - Media flat cables 1 and 2
 - Power supply harness
 - NCU harness
 - Purge switch harness
 - Speaker harness
 - Hook switch harness (Unhook the ferrite core from the core support B.)
 - Paper ejection sensor harness

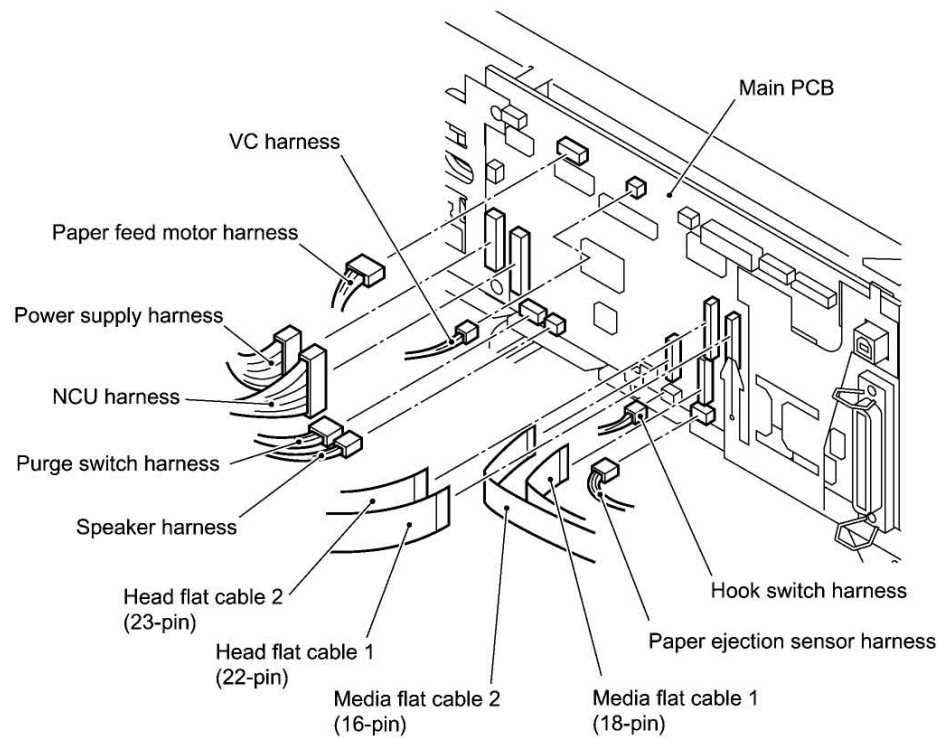

- (2) Remove the five screws--two from the left side of the main PCB and three from the main shield plate (when viewed from the rear), then remove the main shield plate and main PCB from the main chassis.
- (3) Take out the harnesses (VC harness, power supply harness, NCU harness, speaker harness, and purge switch harness) from the core support A.
- (4) Pull out the head flat cables from the flat core(s) and remove the flat core(s) from the core support A.

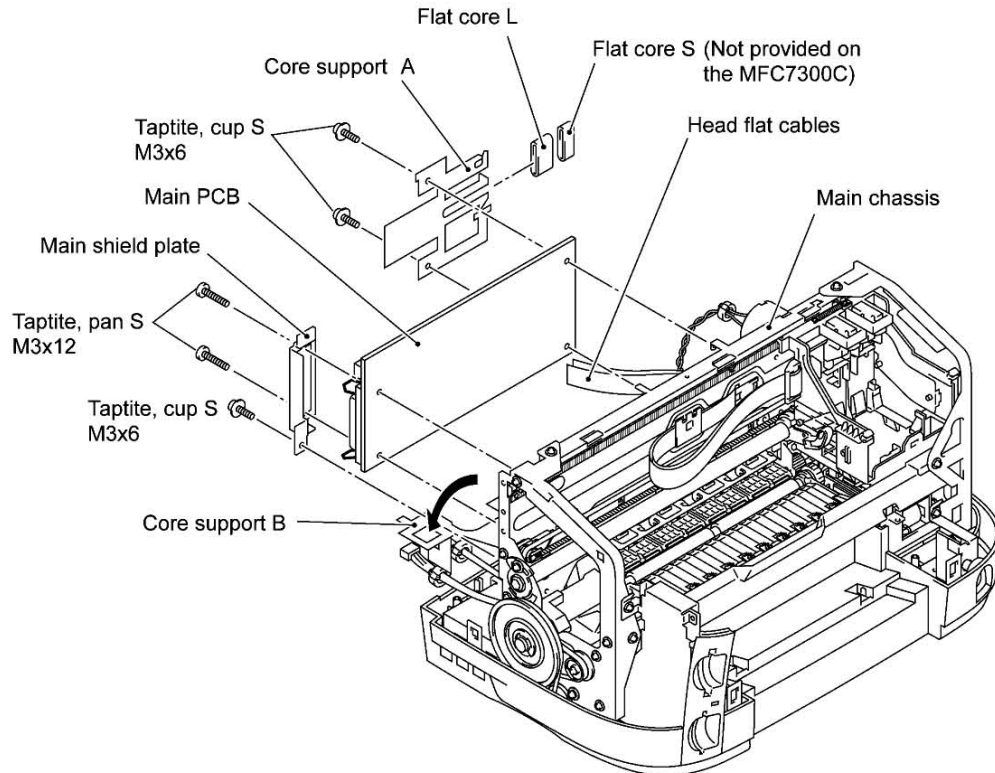

- (5) Take out the harnesses (hook switch harness, paper ejection sensor harness, and media flat cables) from the core support B. Then remove the core support B.

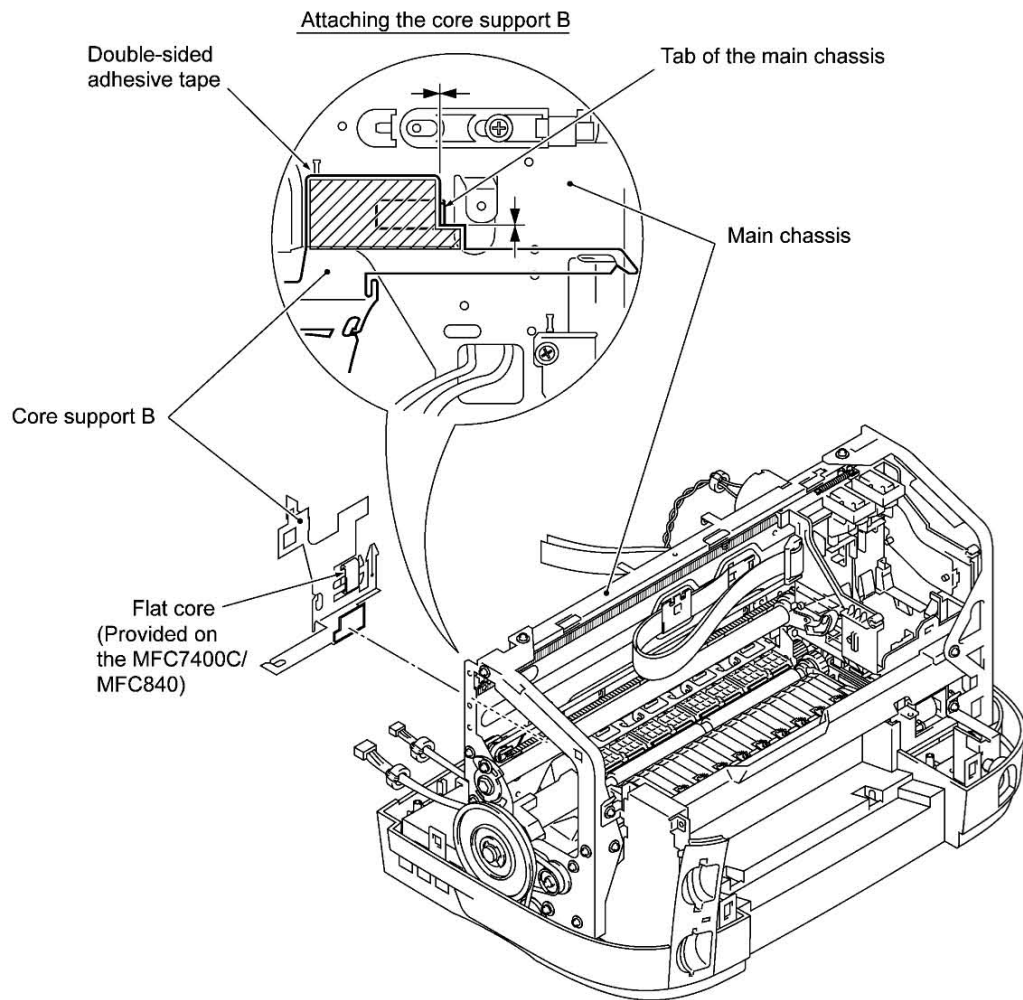

■ Reassembling Notes

- When attaching the core support B, position it as illustrated above.

- When setting the main PCB back into place, be sure to put the registration sensor actuator into the registration sensor on the main PCB as shown below.
- Secure the left edge of the main PCB together with the core support A with two screws, and the right edge together with the main shield plate with three screws, when viewed from the rear. (See page IV-31.)
- Set the flat cores onto the core support A and pass the head flat cables through the flat cores as shown below.
- Pass the media flat cables through the flat core on the core support B and then fit the core support B over the USB connector.
- Tilt the three electrolytic capacitors on the main PCB to the left (when viewed from the rear) as illustrated on the next page. This is to prevent those capacitors from interfering with the ASF which will be installed later.

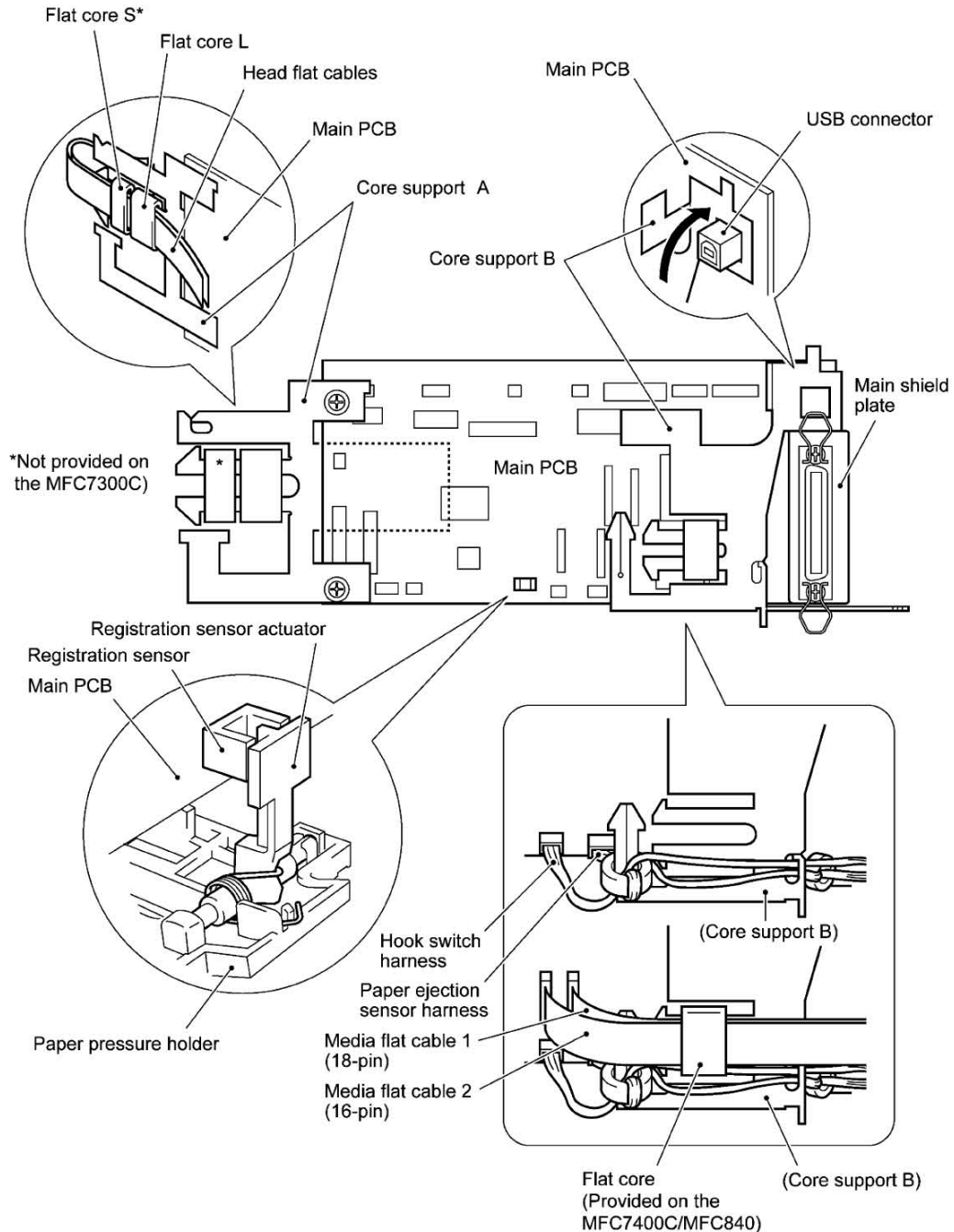

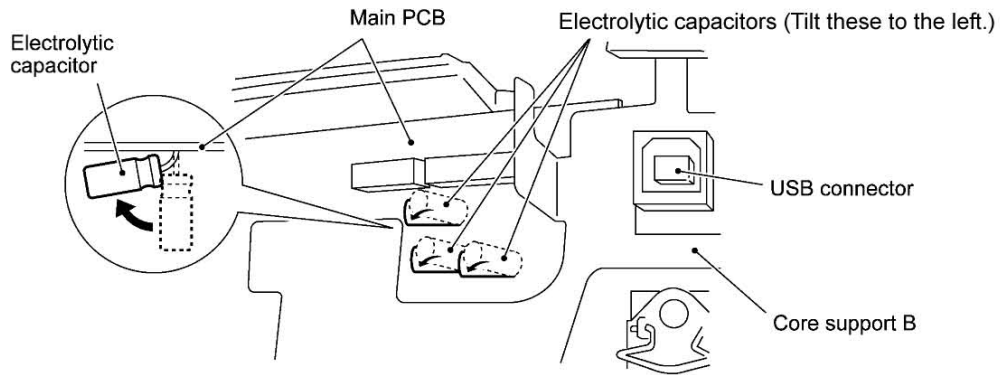

- Route the harnesses, referring to Section 1.26.
- After you replace the main PCB, be sure to follow the flowchart given on the next page.

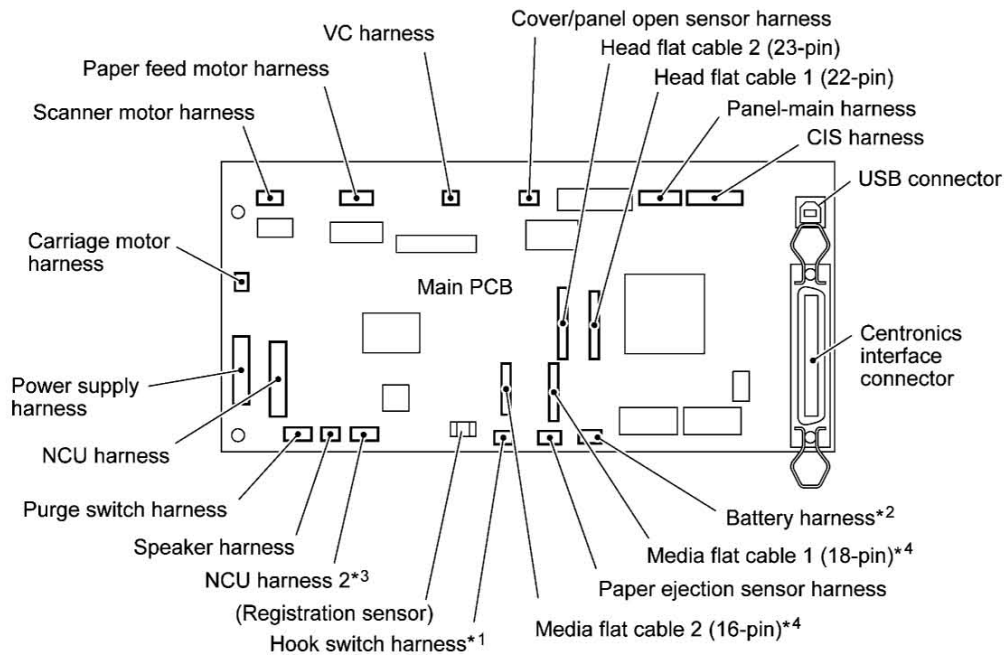

- *1 Not provided on models w/o handset.
- *2 Provided on some European models.
- *3 Not provided on American models.
- *4 Not provided on models w/o PhotoCapture Center.

Setting up the main PCB after replacement

----- Important -----

NOTE: Before starting the following procedure, make sure that the print head unit is installed.

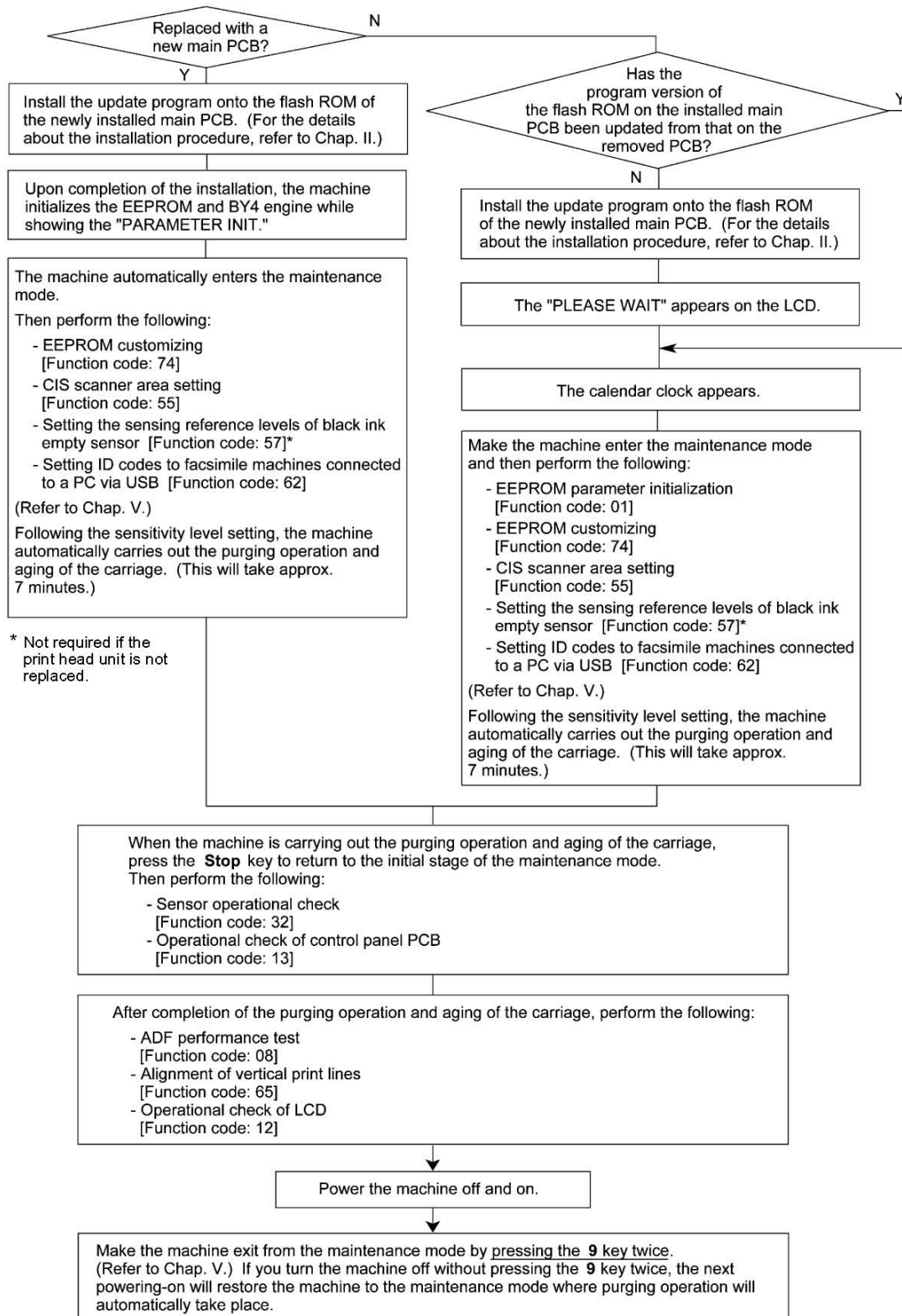

1.12 Media Guide, Media PCB and Media Shield Plate

- (1) Pull the upper section of the media guide to the front to release the two latches from the bottom cover.
- (2) Remove the three screws from the media shield plate.
- (3) Disconnect the media flat cables 1 and 2 from the media PCB, then take out the media shield plate together with the media PCB.

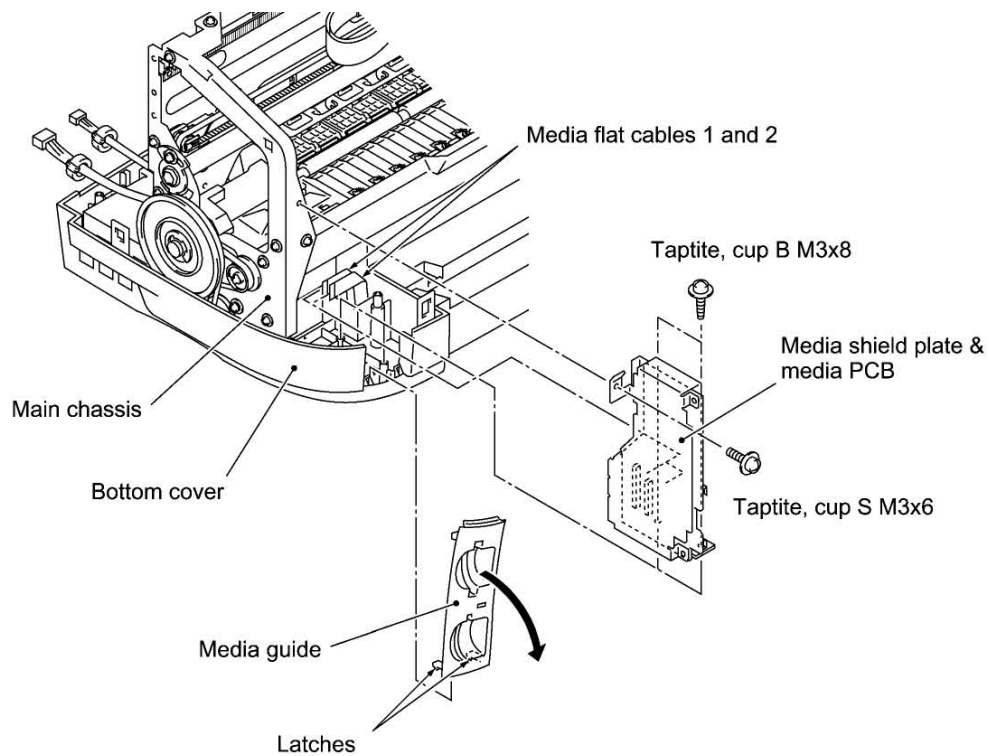

- (4) Unhook the two latches to release the lens from the media guide.

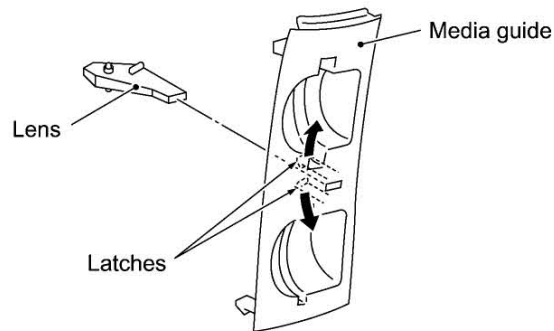

(5) Remove the two screws from the media PCB.

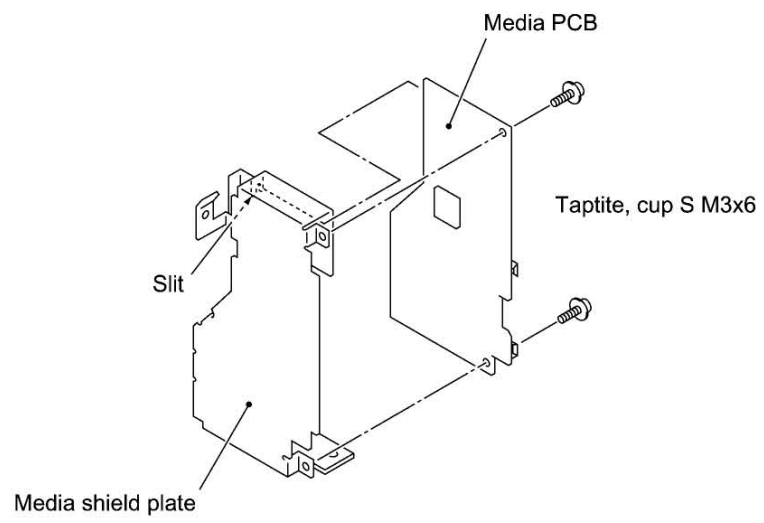

1.13 VC Connector PCB and its Bracket

- (1) Remove two screws ("a" and "b") to release the VC bracket.
- (2) Disconnect the VC harness from the VC connector PCB.
- (3) Remove screw "c" to release the VC connector PCB from its bracket.

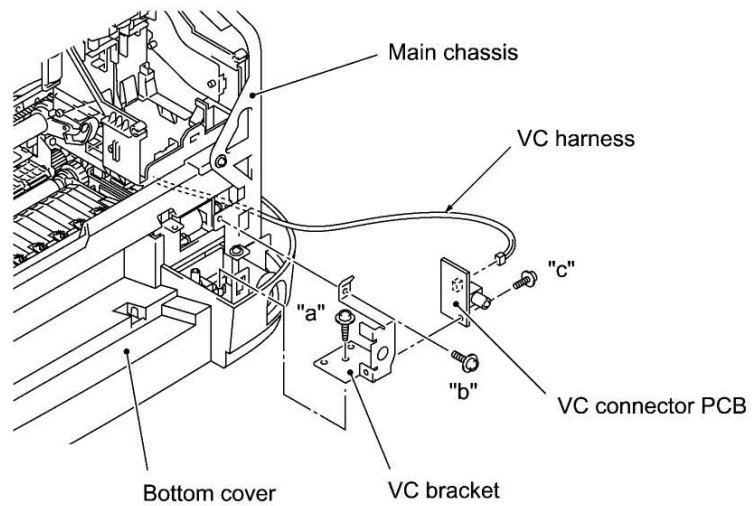

"a": Taptite, cup B M3x8

"b" and "c": Taptite, cup S M3x6

1.14 Power Supply PCB and NCU PCB

- (1) Remove adhesive tape from the drain tube on the NCU/PS shield box and pull out drain tube from the ink absorber felts.

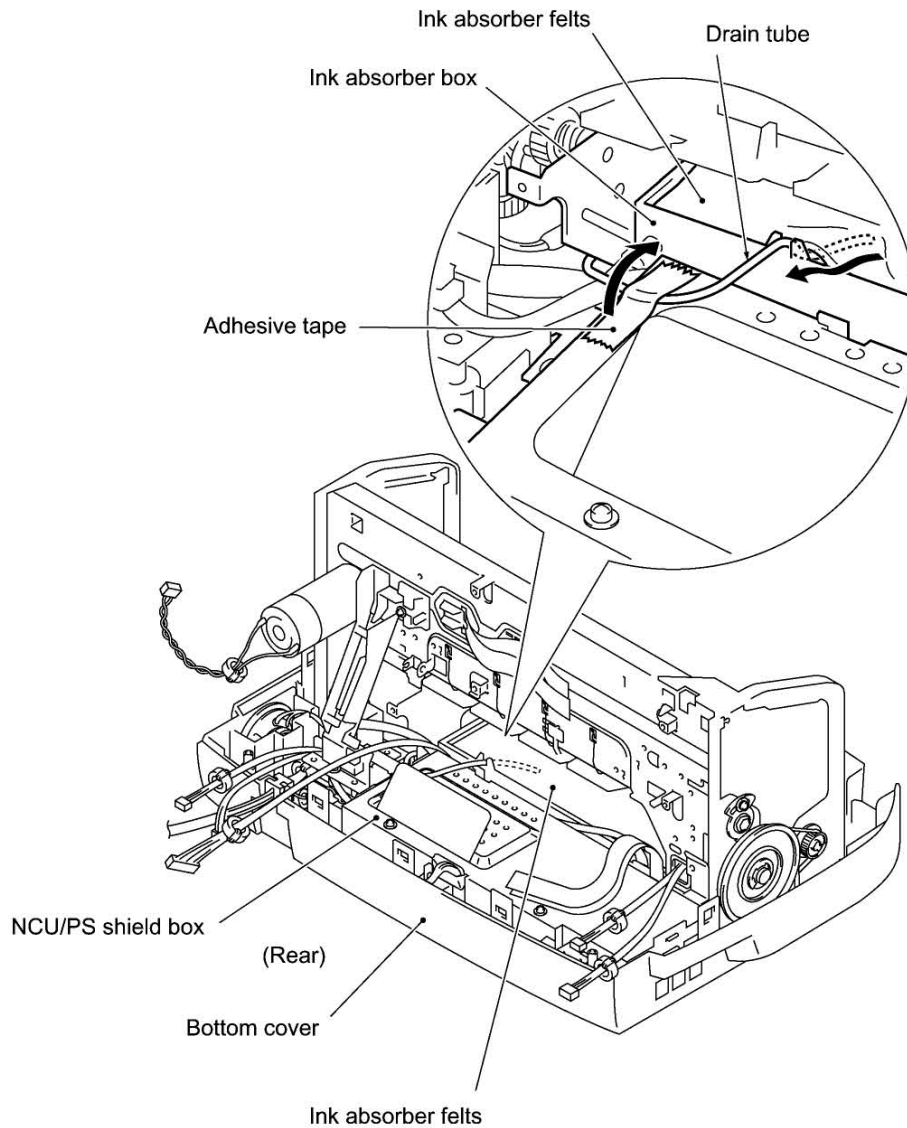

- (2) Remove the two screws to release the grounding plate.
- (3) Remove the two screws from the NCU/PS shield box.
- (4) Take out the NCU/PS shield box from the bottom cover.

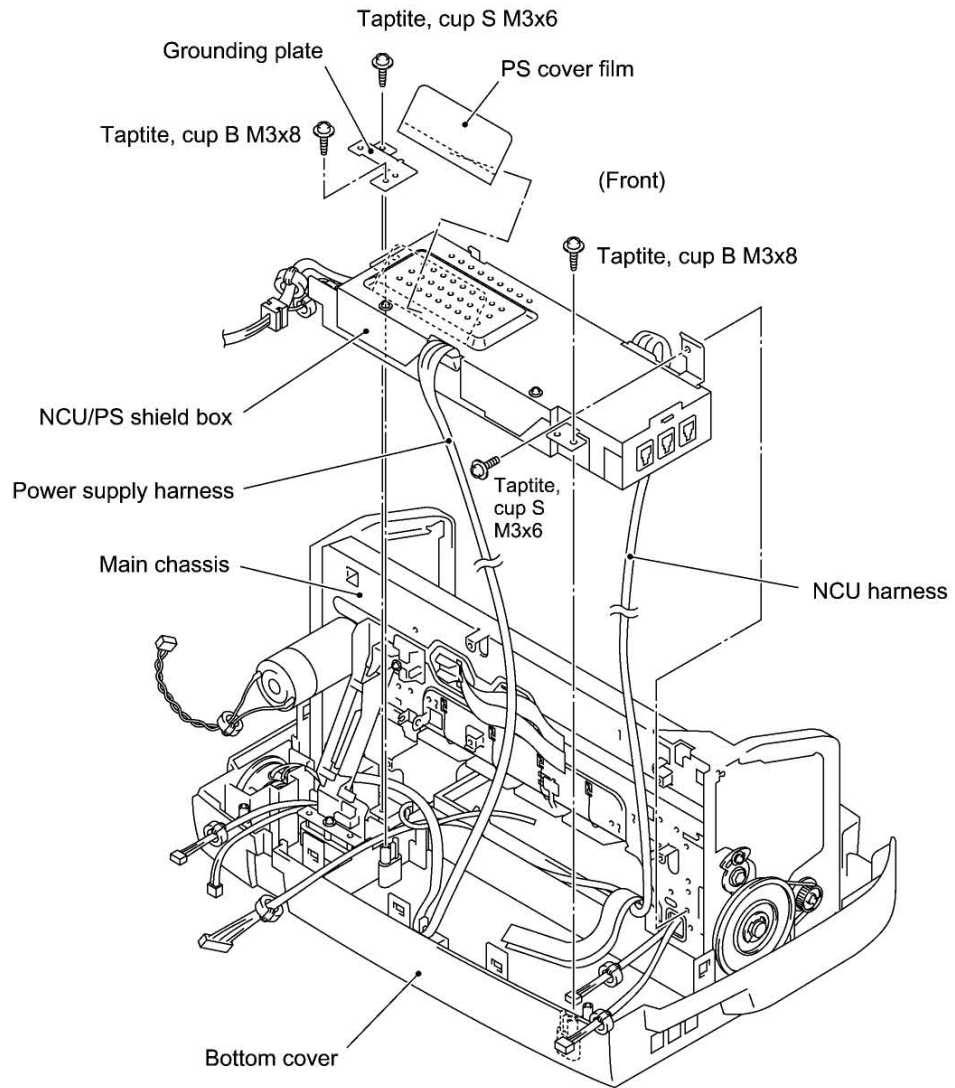

- (5) Remove two screws "a" and take off the upper NCU/PS shield.
- (6) Disconnect the NCU harness from the NCU PCB, remove screw "b," and take out the NCU PCB.
- (7) Remove screw "d" to release the grounding terminal from the lower NCU/PS shield.
- (8) Disconnect the power supply harness from the power supply PCB, remove two screws "c," and take out the power supply PCB.

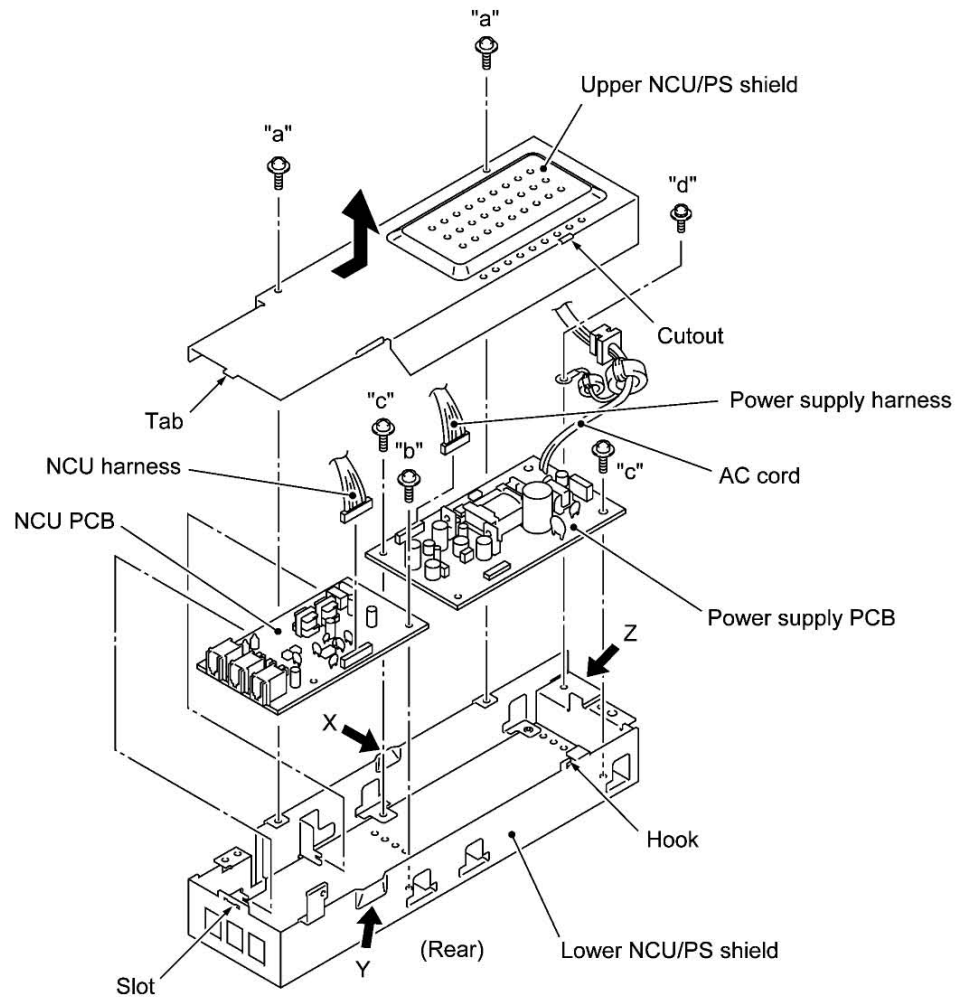

"a," "b," and "c": Taptite, cup S M3x6
 "d": Screw, pan (w/ washer) M4x8DB

■ Reassembling Notes

- When assembling the upper and lower NCU/PS shields in a box, route the power supply harness, NCU harness, and AC cord through "X," "Y," and "Z" sections (shown on the previous page), respectively, for preventing them from getting pinched between the upper and lower NCU/PS shields.
- After setting the NCU/PS shield box back into the bottom cover, be sure to insert the end of drain tube between the 1st and 2nd layers of felts in the ink absorber box by 50 mm and tape the drain tube onto the NCU/PS shield box, as illustrated below.

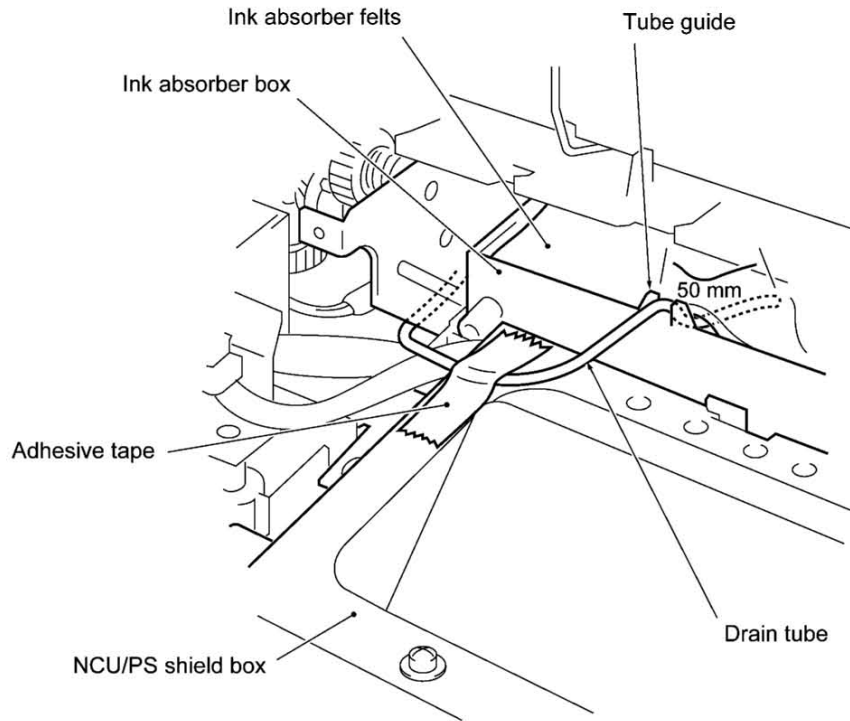

1.15 Harness Supporter and Speaker

- (1) Press the speaker spring in the direction of arrow ① and pull it up (arrow ②).
- (2) Take the speaker up and out of the bottom cover.
- (3) Remove the two screws to release the harness supporter.

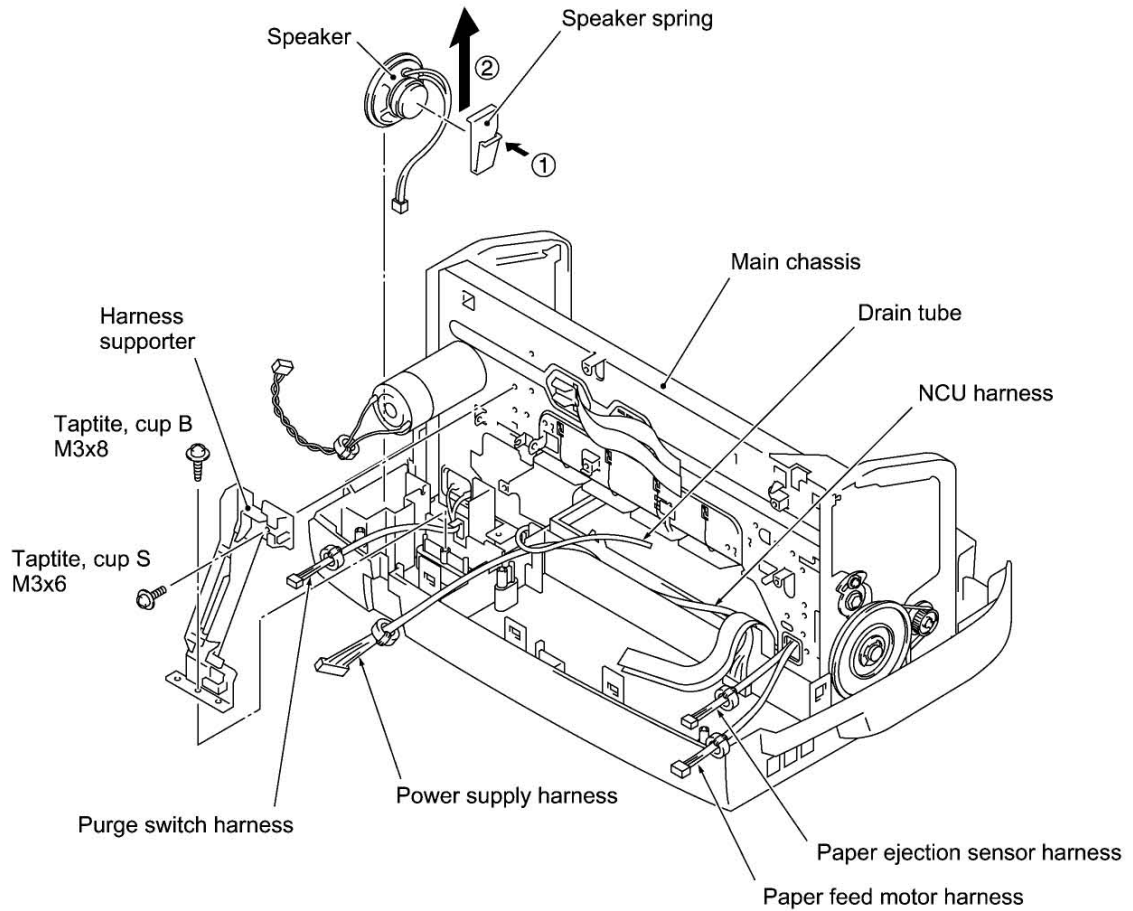

1.16 Main Chassis

- (1) Remove the four screws to release the main chassis from the bottom cover.
- (2) Lift up the main chassis.

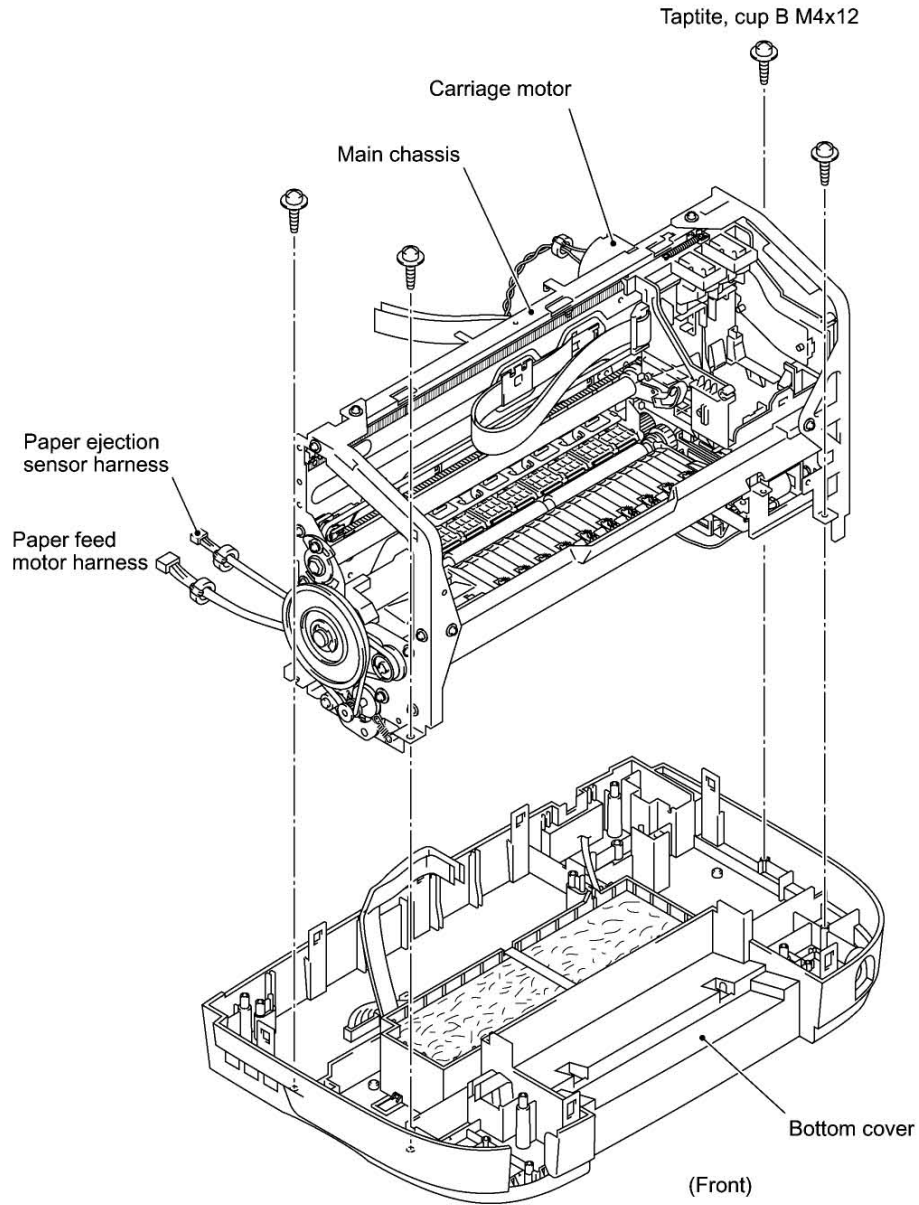

1.17 Ink Absorber Box

If the print head unit is replaced with a new one, replace also the ink absorber box with a new one.

- (1) Push the locking arm in the direction of arrow ① and remove the ink absorber box in the direction of arrow ②.

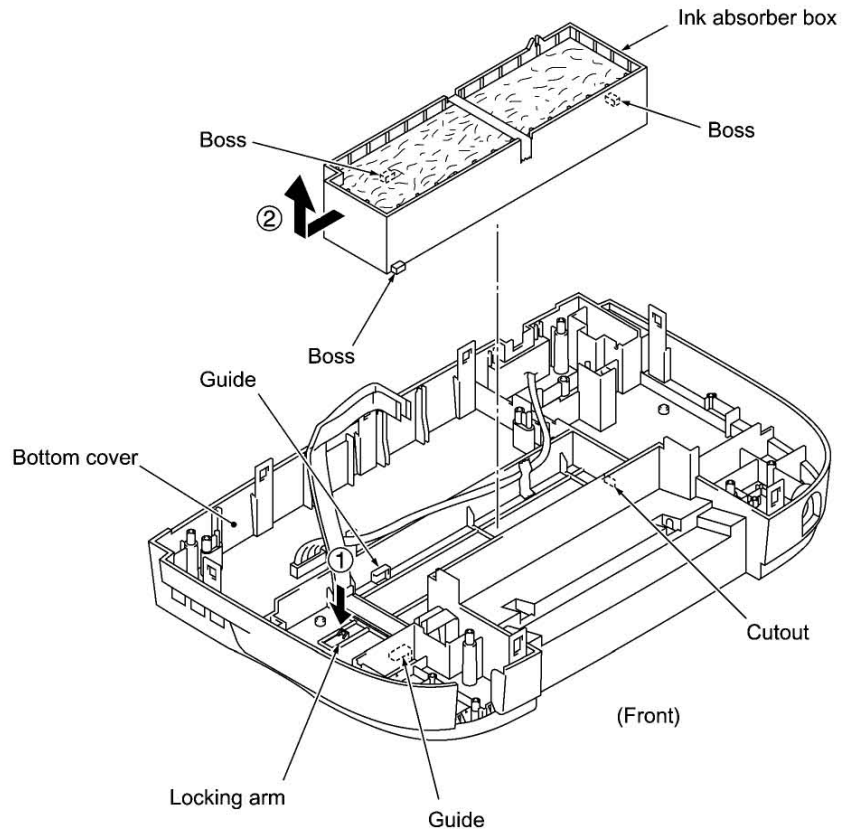

1.18 Media Flat Cables and NCU Harness

- (1) Take out the media flat cables from the bottom cover.
- (2) Remove adhesive tape to release the NCU harness from the bottom cover.

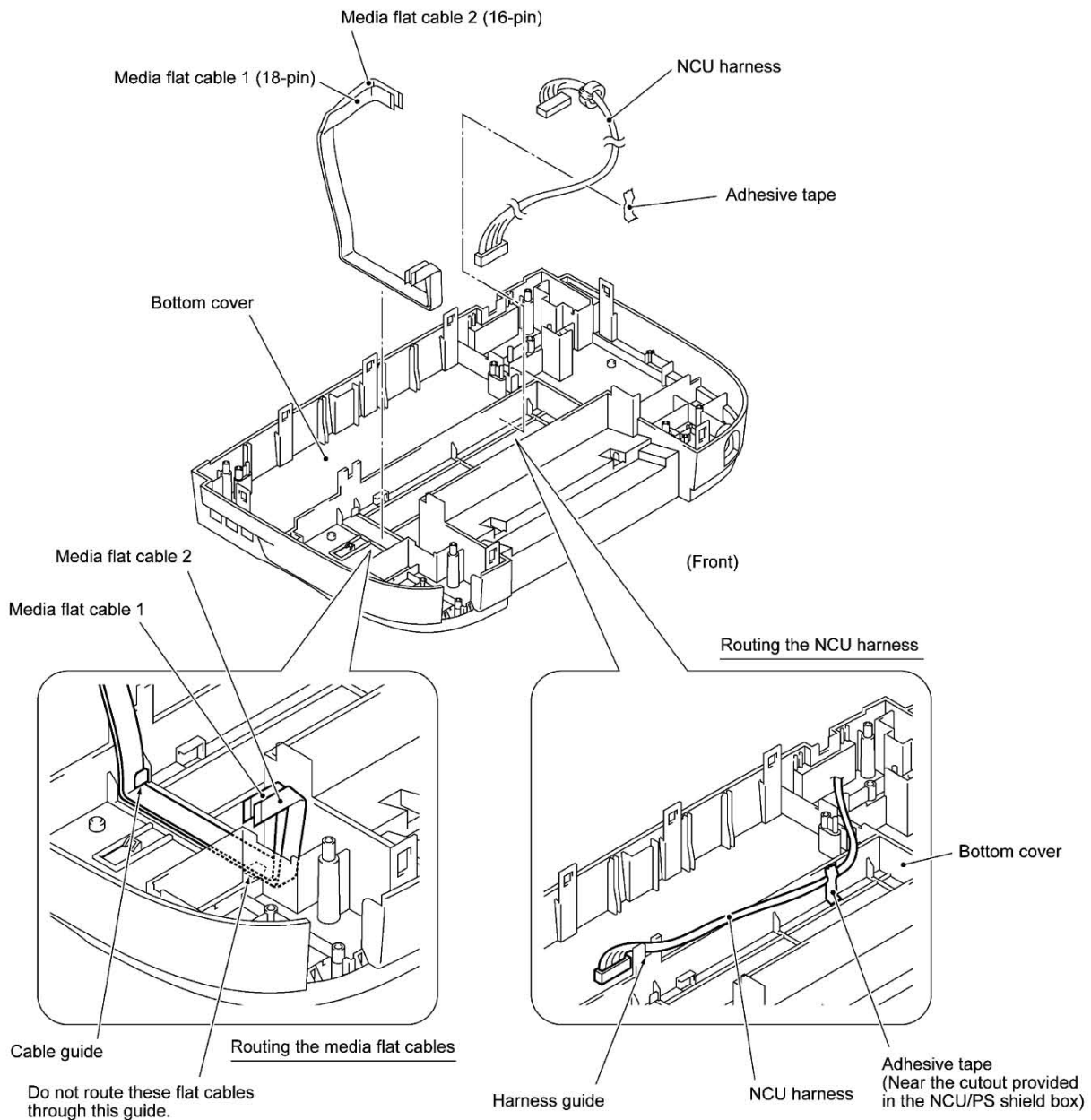

■ Reassembling Notes

- Route the media flat cables and NCU harness on the bottom cover as illustrated above.

1.19 Purge Unit, Purge Switch Harness (Purge-related Switches), and Gears

- (1) Move the carriage to the left and out of the home position.

NOTE: If the carriage is locked in the home position, you need to turn the PF roller pulley L in the direction of arrow ① to retract the carriage lock and then move the carriage to the left (arrow ②).

- (2) Turn the gear stopper in the direction of arrow ③ and move the purge bevel gear 18 in the direction of arrow ④ to release the purge gear 16/18.

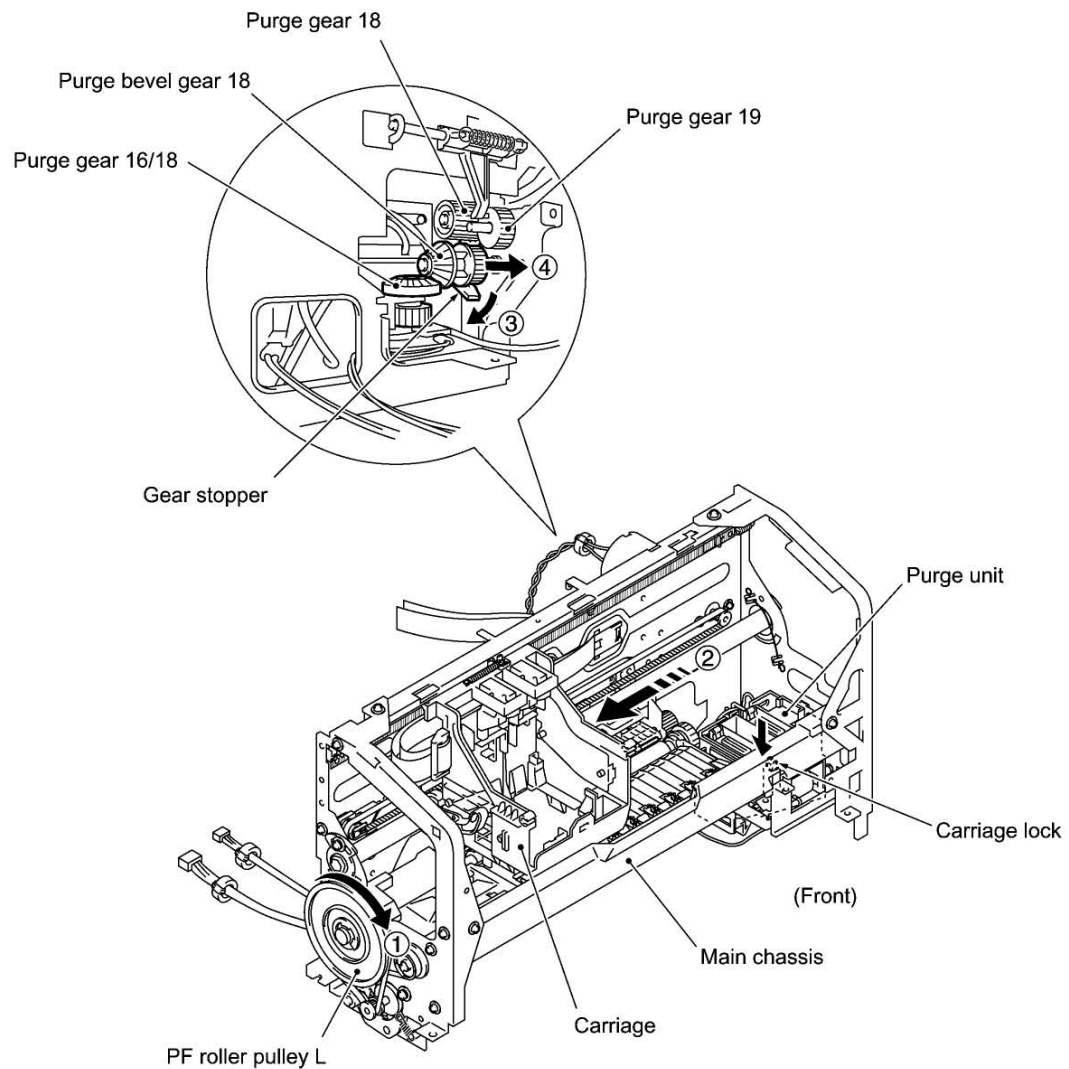

- (3) Remove the two screws from the top of the purge unit and from the right side of the main chassis.
- (4) Take the purge unit up and out of the main chassis.

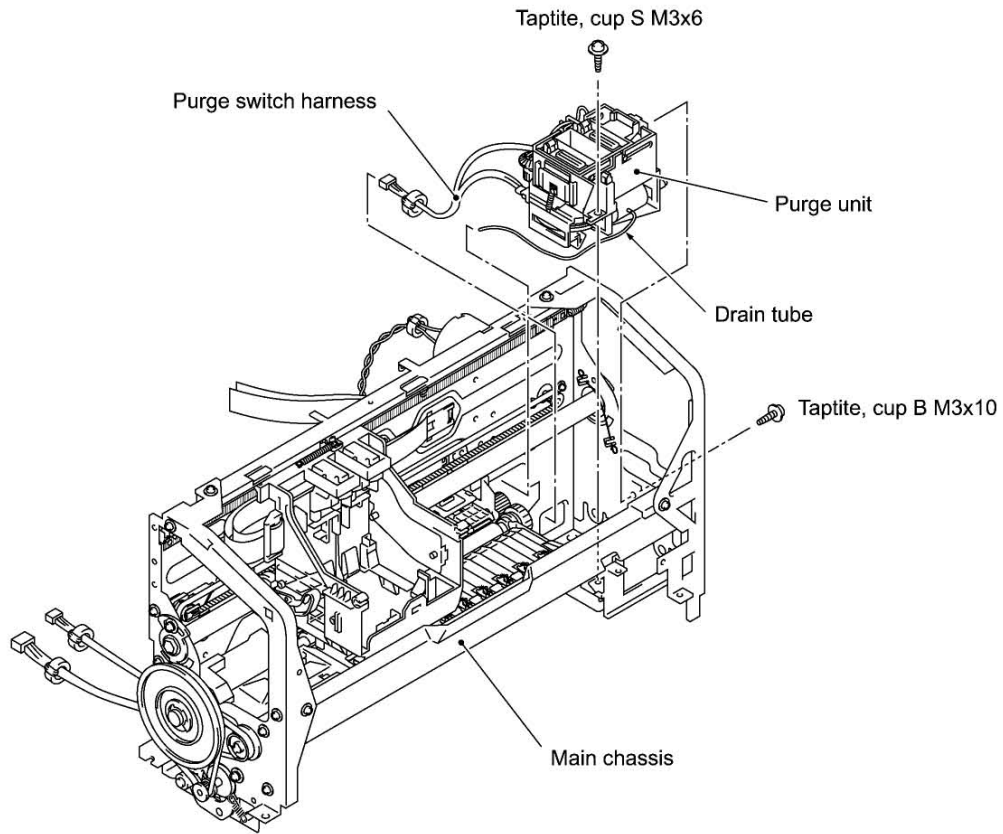

- (5) Take off the purge cam HP switch and pump switching cam HP switch from the purge unit by pulling the latches outwards, respectively.

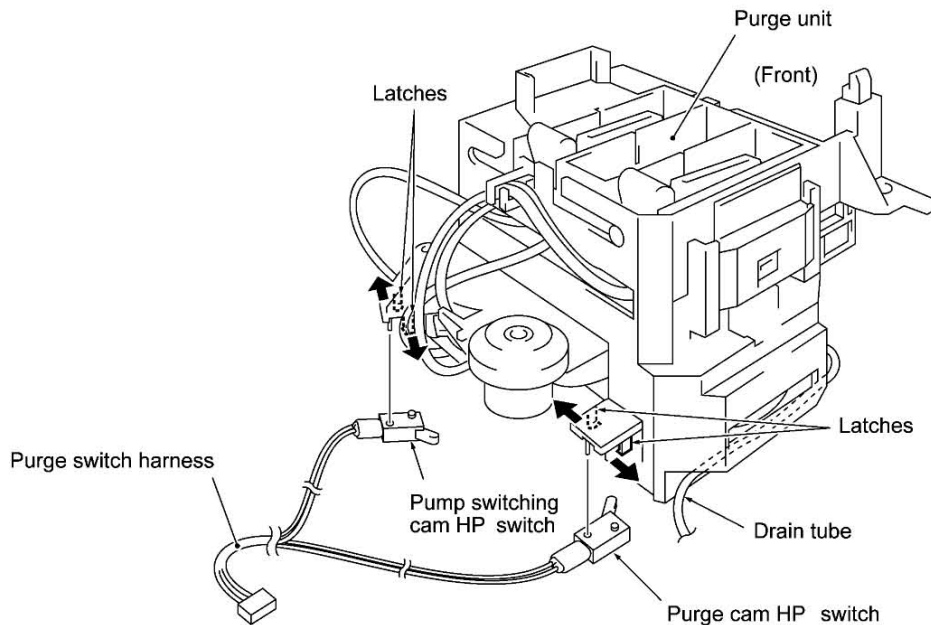

- (6) From the rear left of the main chassis, remove the purge bevel gear 18.
- (7) Unhook the purge lever spring and remove the purge lever and its shaft. The purge gear 19 and its spring also come off.
- (8) Remove the purge gear 18 by pulling its pawl outwards. Also remove the gear stopper.

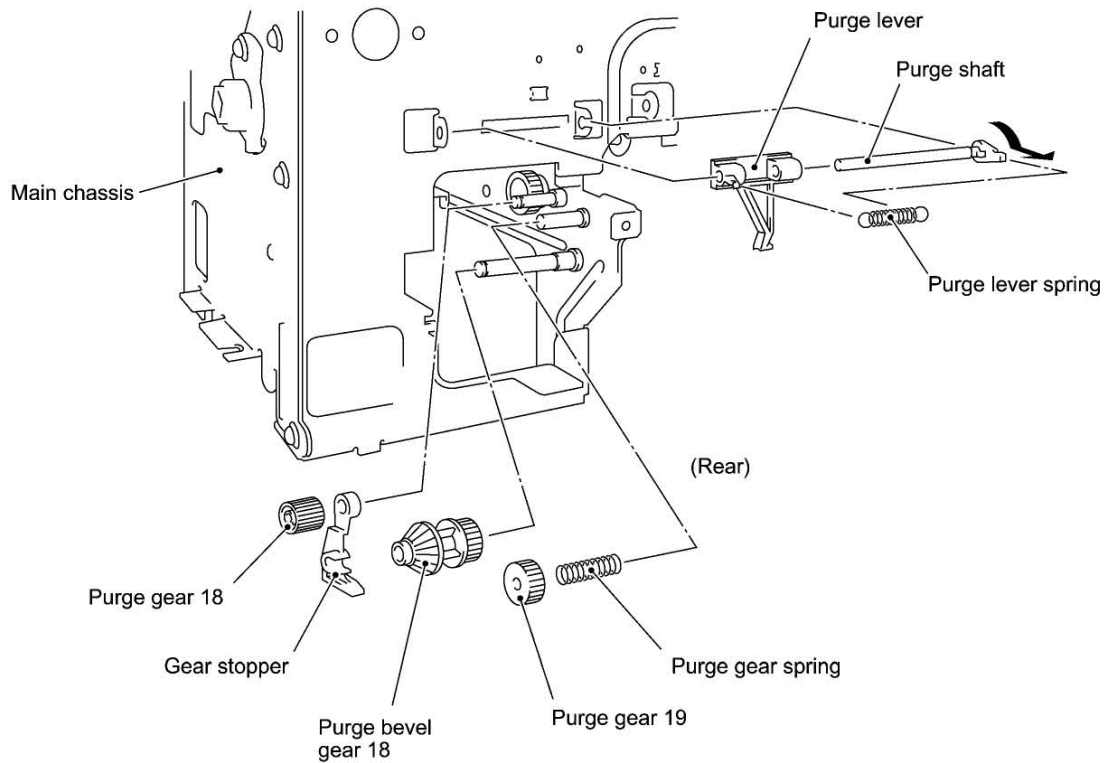

■ Reassembling Notes

- After installing the purge unit, move the carriage to the right and left ends by hand to check that it travels smoothly.

1.20 Platen, Star Wheels, Paper Ejection Sensor and its Actuator

- (1) Move the carriage to the right end of its travel.
- (2) Remove the three screws from the platen.
- (3) Take the platen up and out of the main chassis.

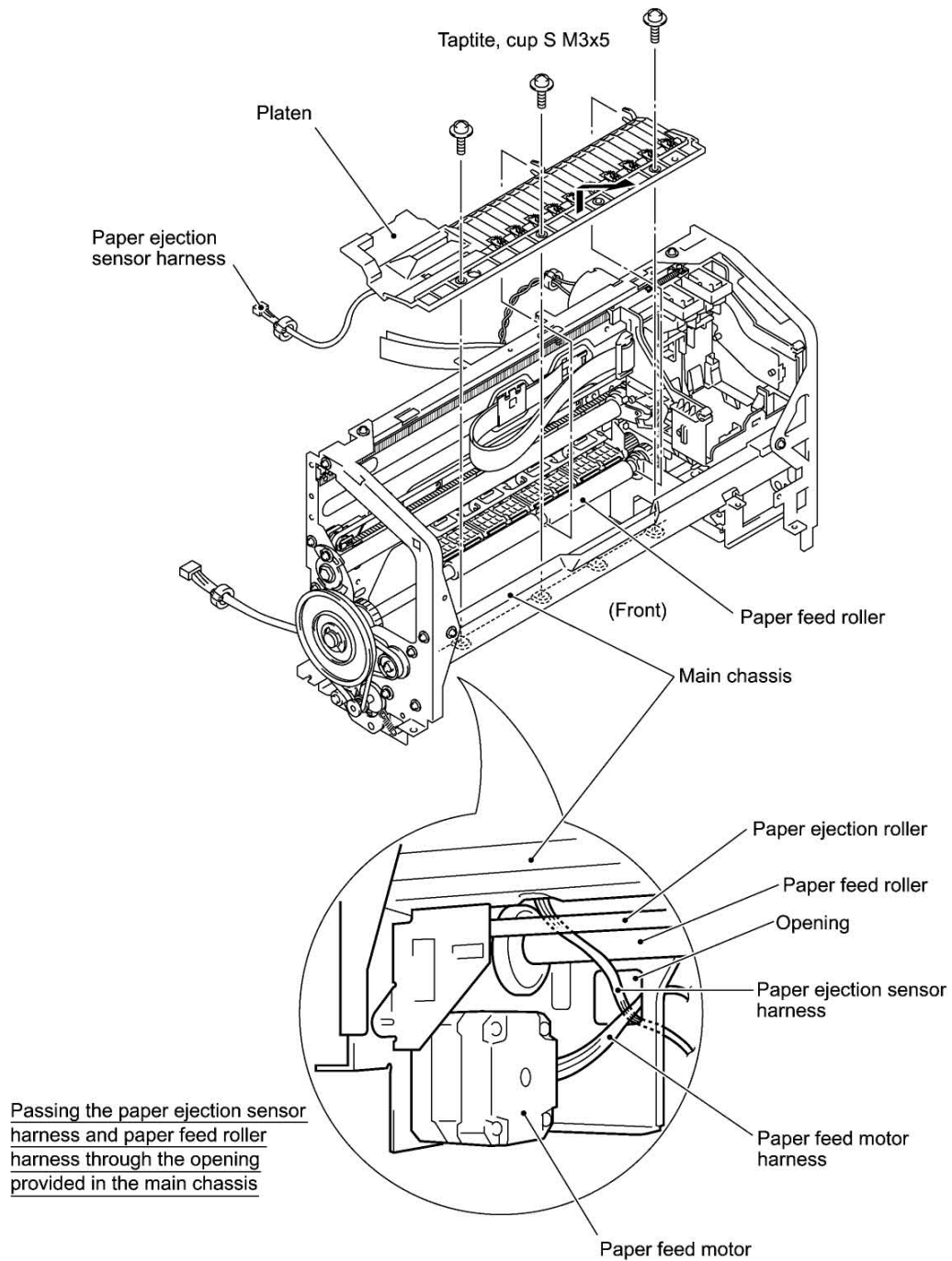

- (4) Unhook the star wheel films and then pull out the star wheels and their springs.
- (5) Unhook the paper ejection sensor.
- (6) Press the locking arm in the direction of arrow ① and remove the paper ejection sensor actuator in the direction of arrow ②.

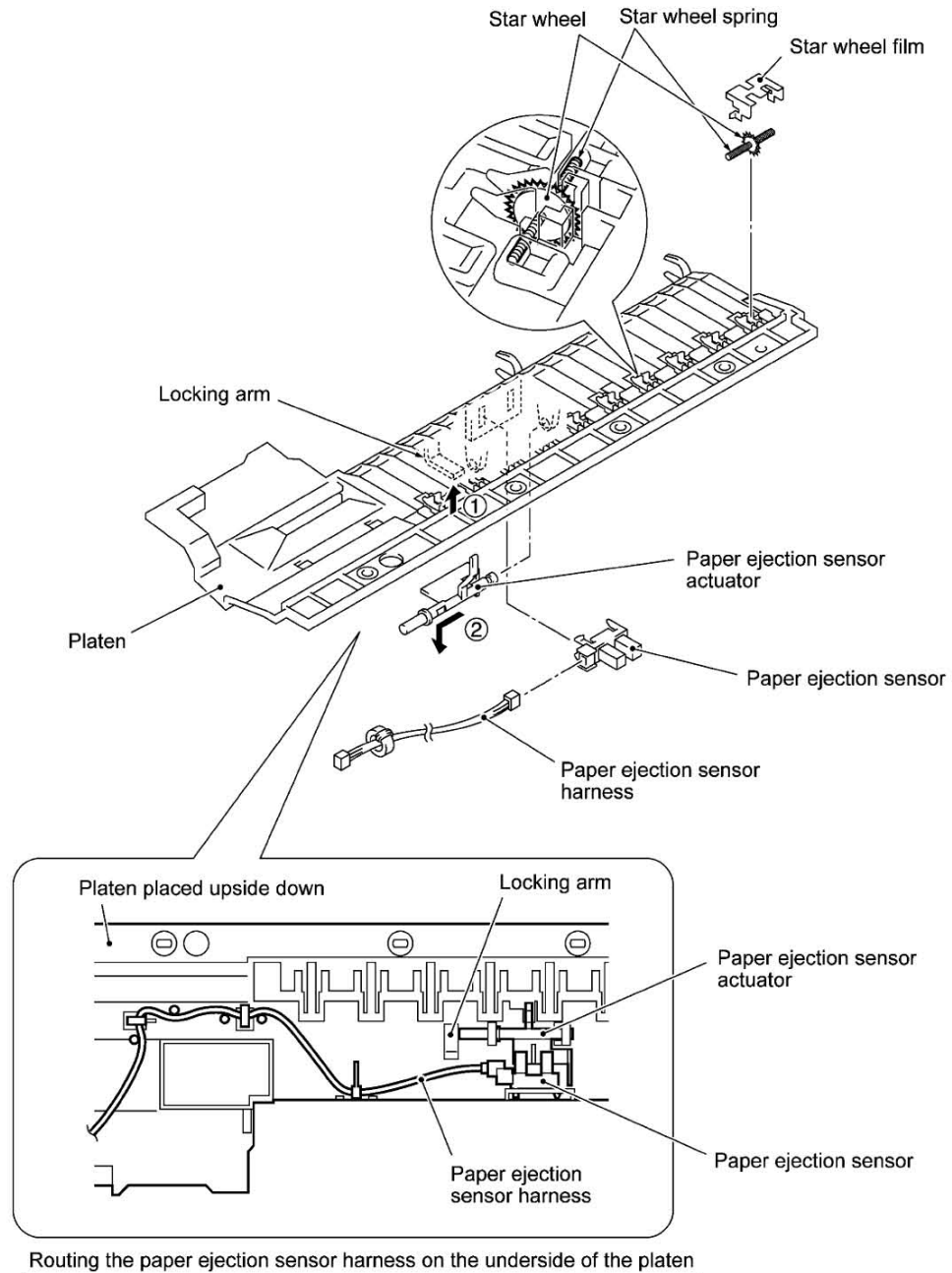

■ Reassembling Notes

- Be sure to hook the latch of each star wheel film to the platen.
- Route the paper ejection sensor harness on the underside of the platen as shown above and then pass it through the opening provided in the main chassis from the front to rear as shown on the previous page.
- When securing the platen, be sure to use three M3x5 screws. Do not use longer ones.

1.21 Idle Pulley Related Parts and Carriage Motor

- (1) From the rear right of the main chassis (when viewed from the rear), remove the two screws to release the idle pulley stopper.
- (2) Move the carriage to the center of its travel.
- (3) While pushing the idle pulley holder in the direction of arrow ①, remove the carriage timing belt from the carriage motor pulley (arrow ②). Then remove the carriage timing belt from the idle pulley (arrow ③).
- (4) Remove the idle pulley holder and its spring.

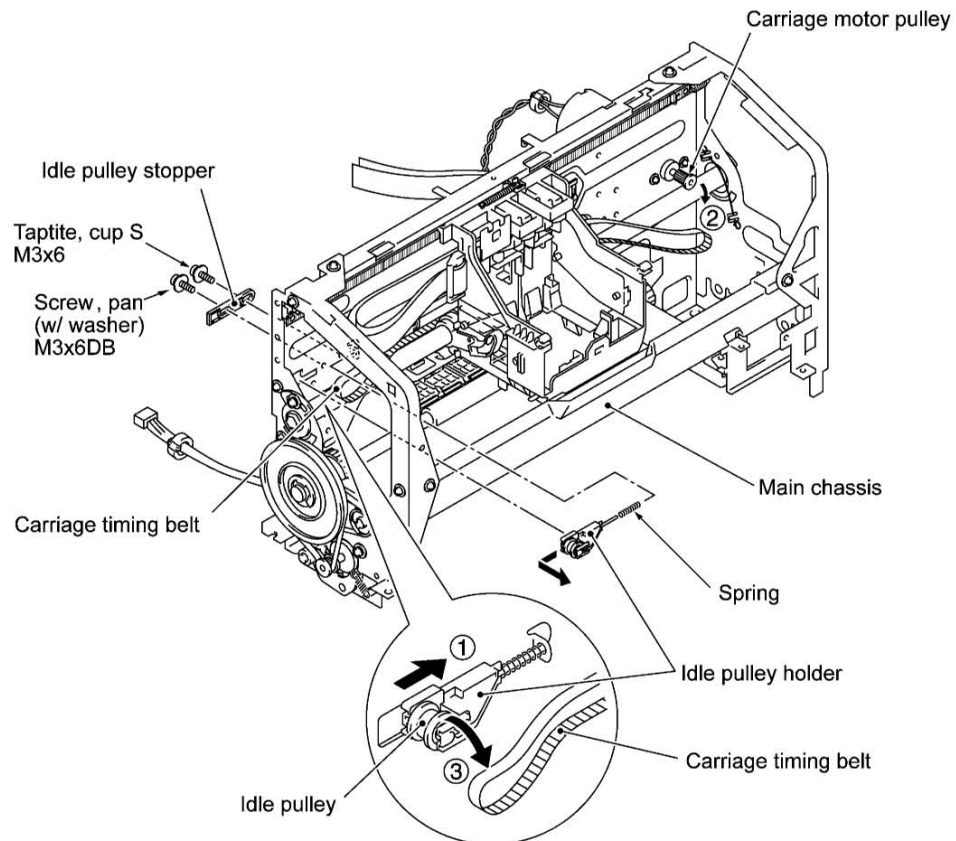

- (5) Remove the idle pulley and its shaft from the idle pulley holder.

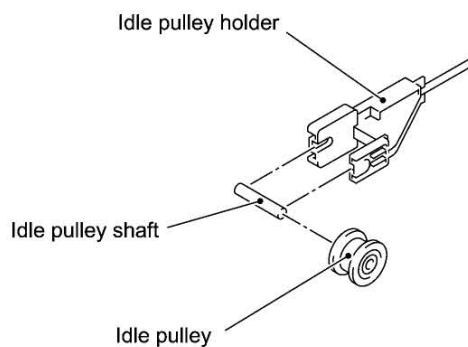

(6) Remove the two screws and take the carriage motor off the main chassis.

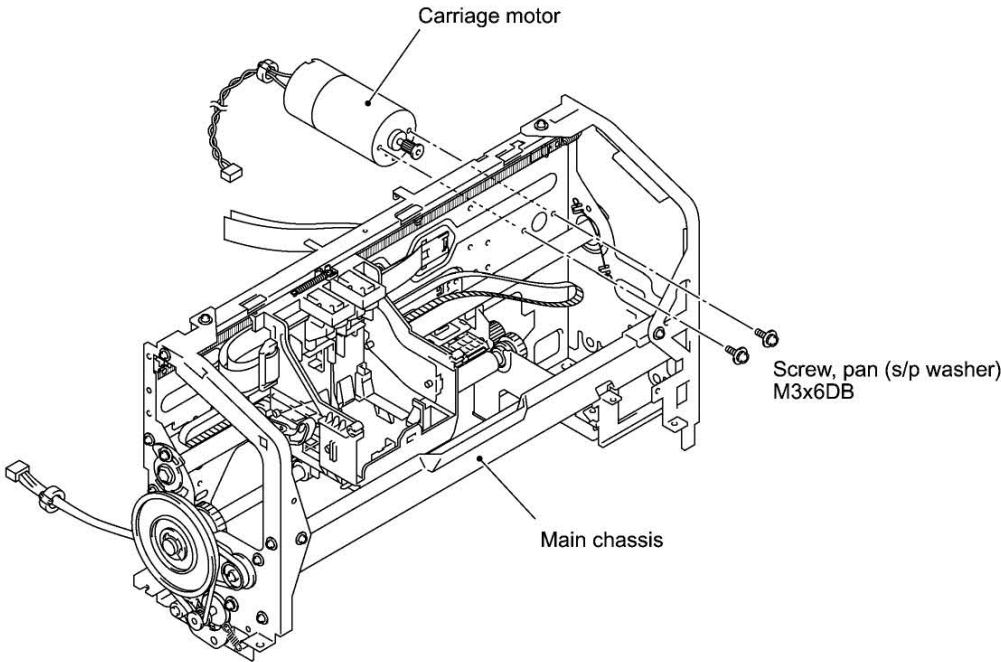

1.22 Paper Pressure Holders and Registration Sensor Actuator

- (1) At each of the paper pressure holders, unhook the top end of the spring from the main chassis in the direction of arrow ①.
- (2) Turn up the front end of the paper pressure holder and take it out to the front (arrow ②) to release the bosses from the hooks provided on the main chassis.
- (3) Remove the springs from the main chassis (arrow ③).

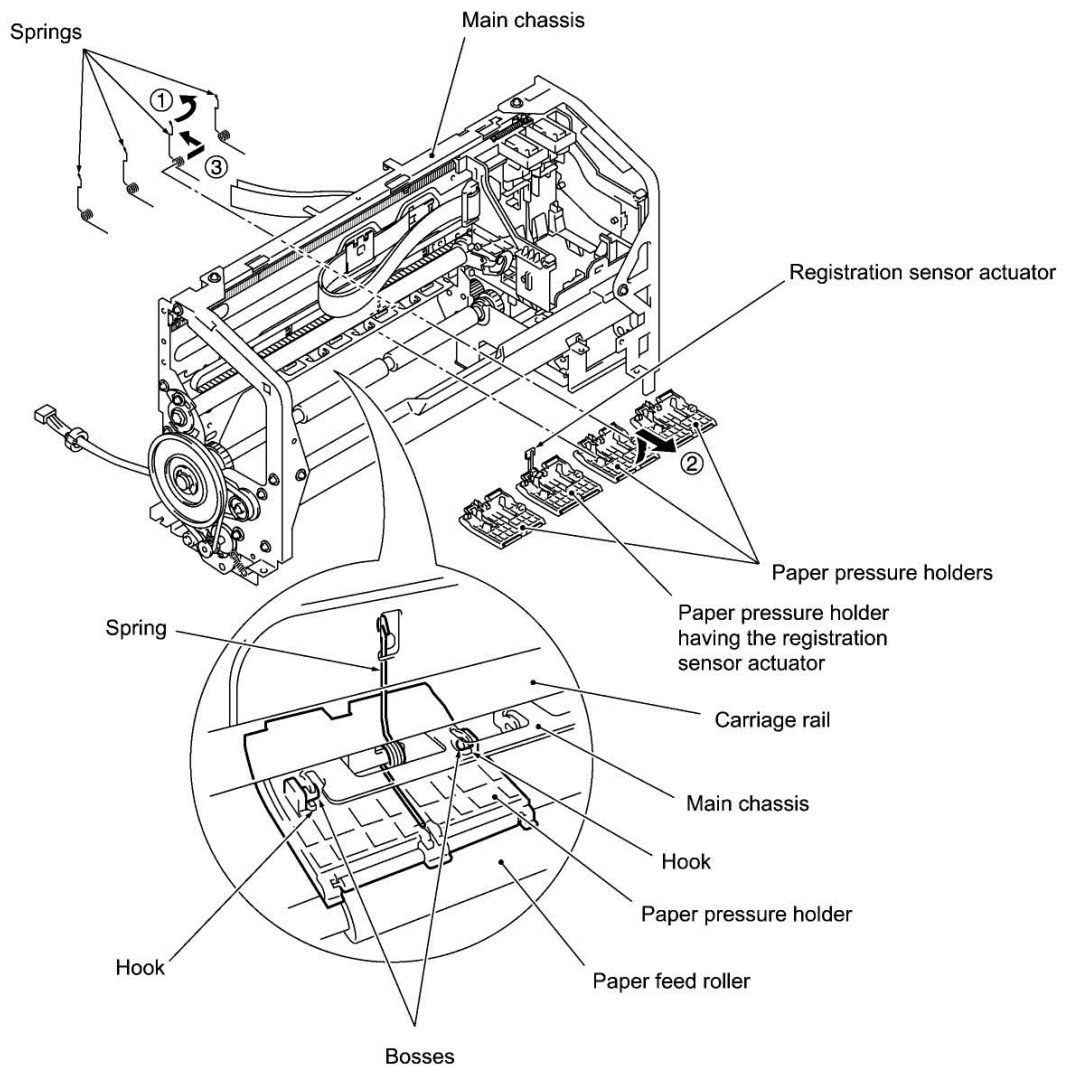

- (4) Turn the registration sensor actuator upright as shown below, then unlatch its left end from the paper pressure holder. The spring also comes off.

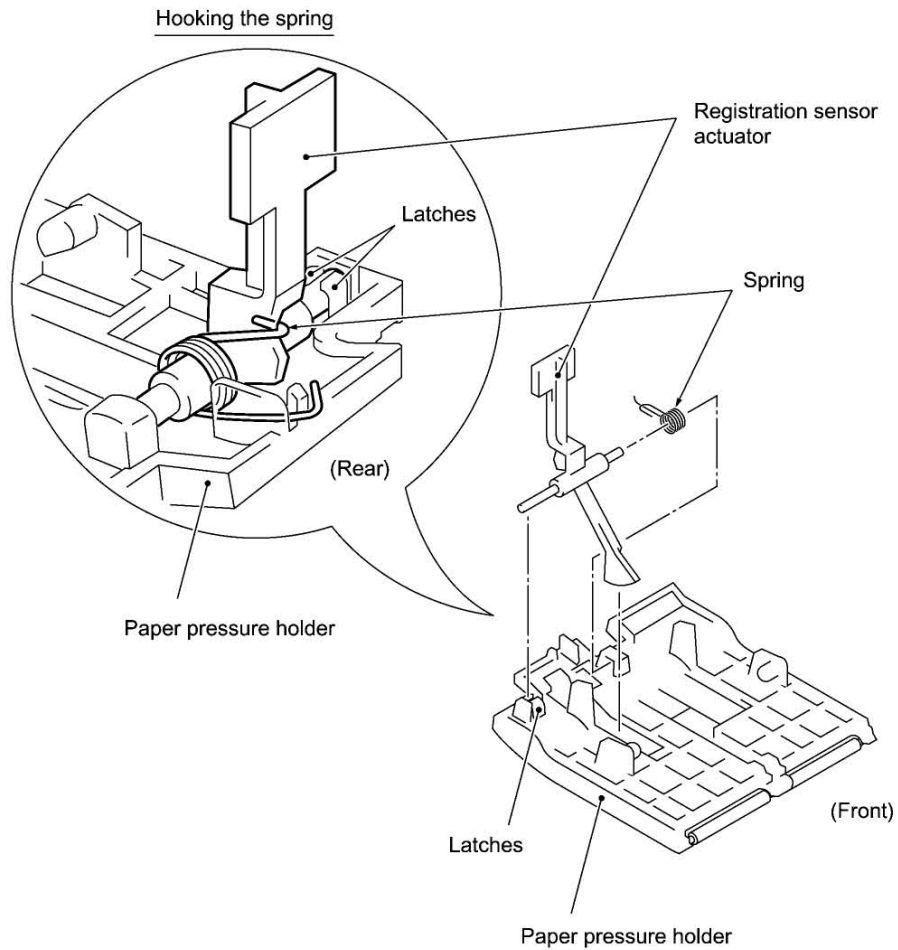

■ Reassembling Notes

- Hook the spring on the registration sensor actuator as illustrated above.
- Be sure to set the paper pressure holder having the registration sensor actuator in the 2nd position from the left when viewed from the front.

1.23 Encoder Strip

- (1) At the right end of the encoder strip, unhook the spring from the main chassis.

NOTE: Take care not to scratch or damage the encoder strip.

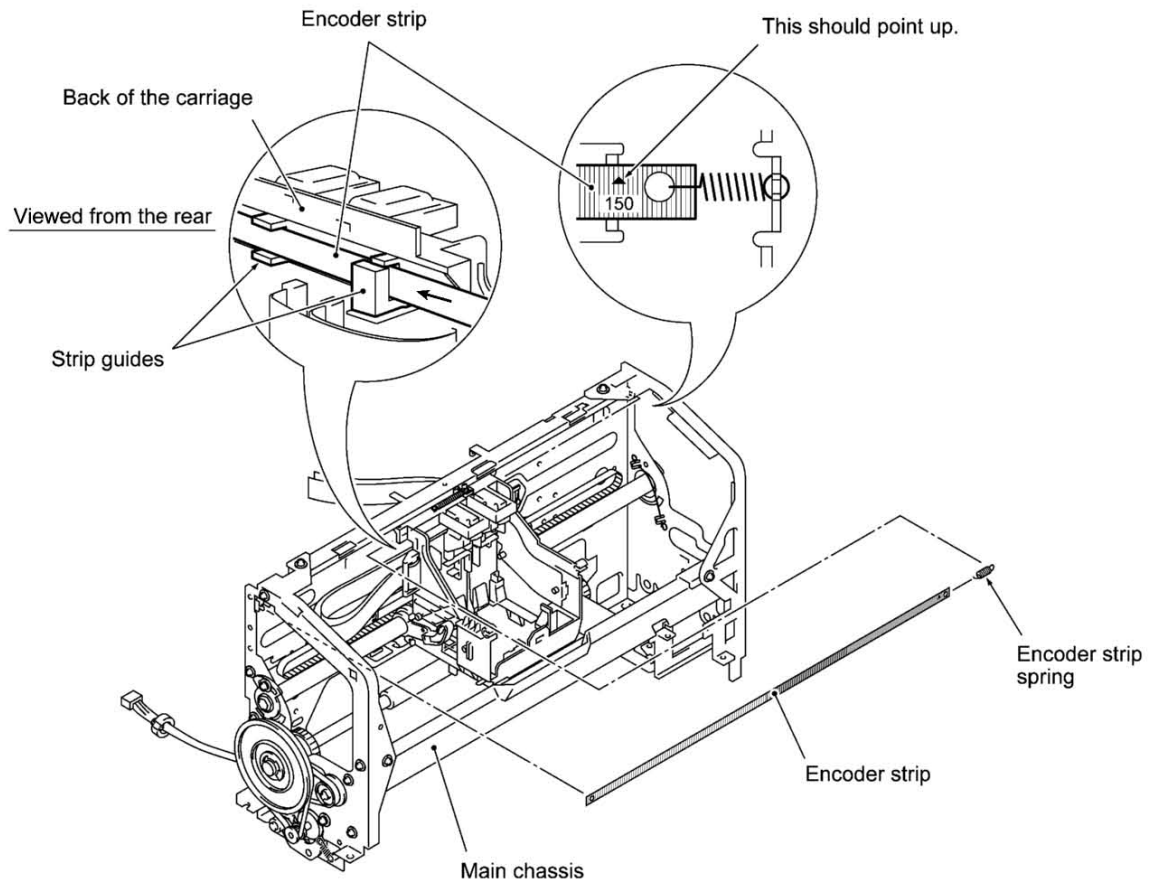

■ Reassembling Notes

- Pass the encoder strip through the strip guides provided on the back of the carriage (from left to right) so that the strip will route as illustrated above and the ▲-marked end comes to the right. Then hook the ▲-marked end on the spring of the main chassis so that the ▲ mark points up.

1.24 Carriage Rail and Carriage ASSY

- (1) At the right end of the carriage rail inside the main chassis, remove the rail pressure spring from the pawls of the main chassis.
- (2) Remove the screw from the eccentric bushing R, then turn the eccentric bushing R clockwise (when viewed from the right) and take it off.
- (3) Pull out the carriage rail to the right. (At the left side of the main chassis, remove the screw from the eccentric bushing L, if necessary, as shown on page IV-61.)

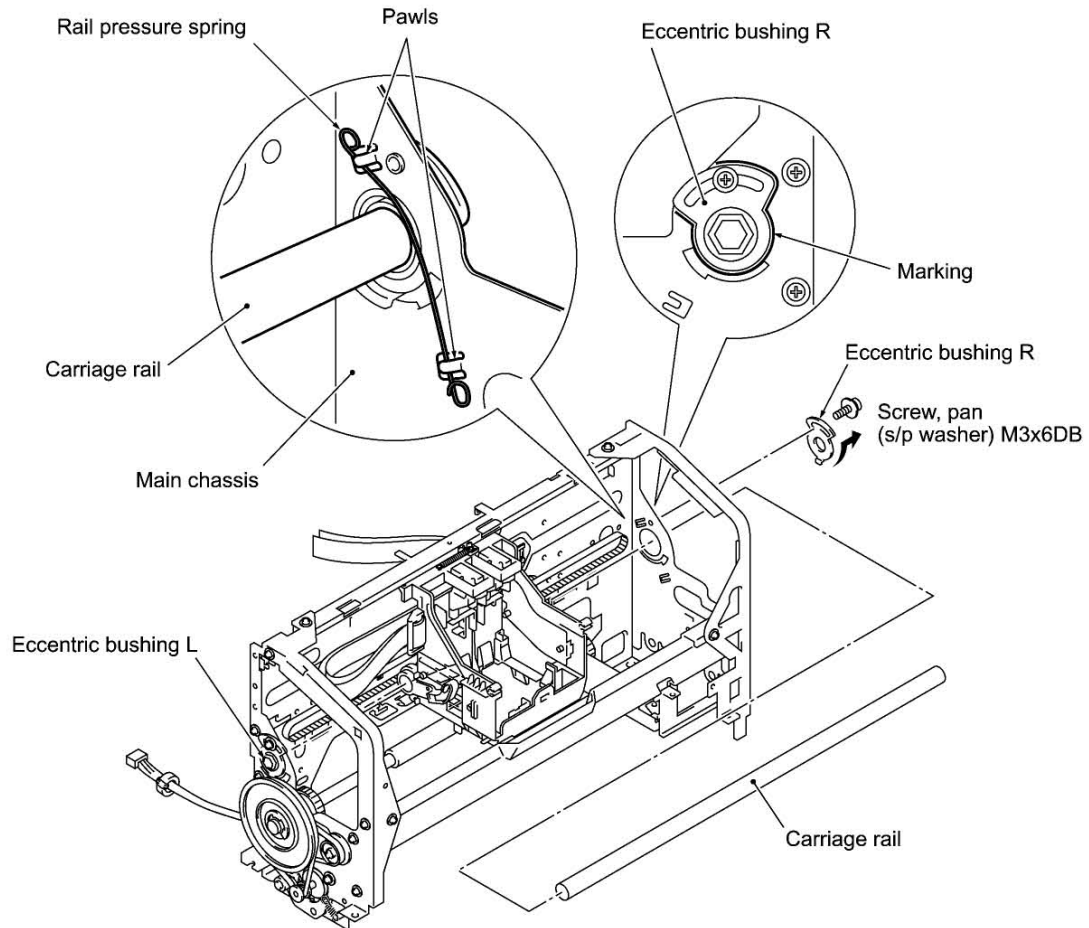

- (4) Unhook the presser spring, turn the carriage presser counterclockwise (when viewed from the top), and lift it up.
- (5) Bring the carriage to the center of the travel (within "X" range shown below) in the direction of arrow ①.
- (6) Lift up the front end of the carriage (arrow ②) and take it out of the main chassis (arrow ③).

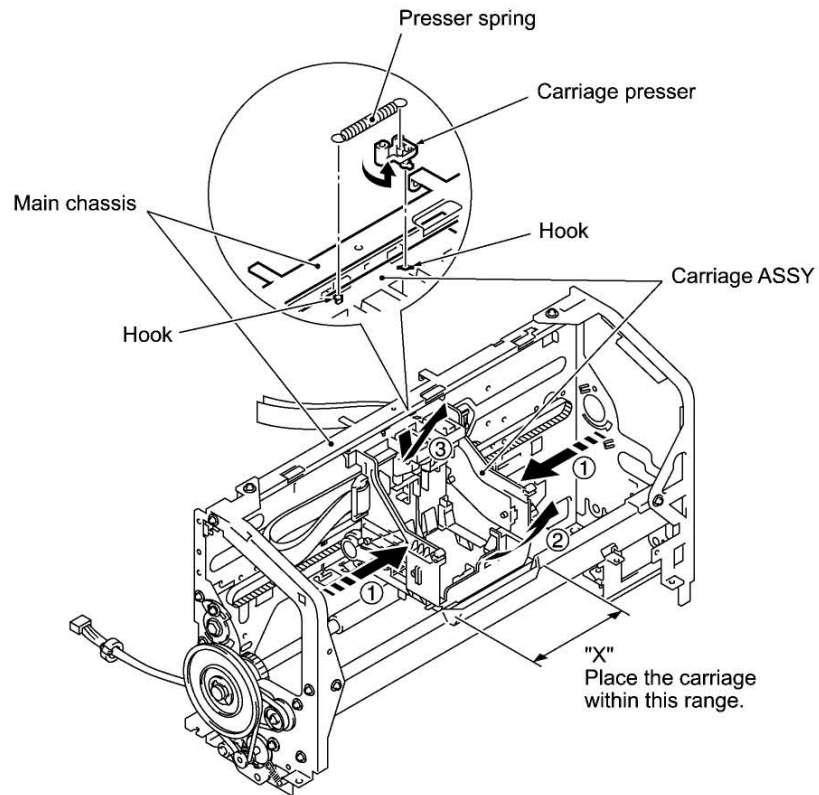

- (7) Unlatch the FFC holders 1 and 2 and remove them to the front to release the head flat cables. The carriage is now completely separated from the main chassis.

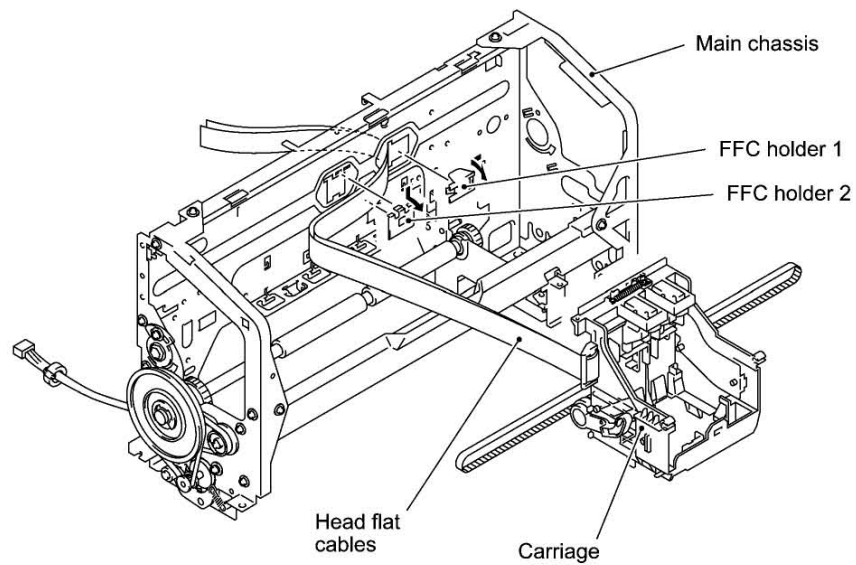

- (8) Remove the timing belt from the back of the carriage.
(9) Remove the head flat cables from the flat cable guide of the carriage.

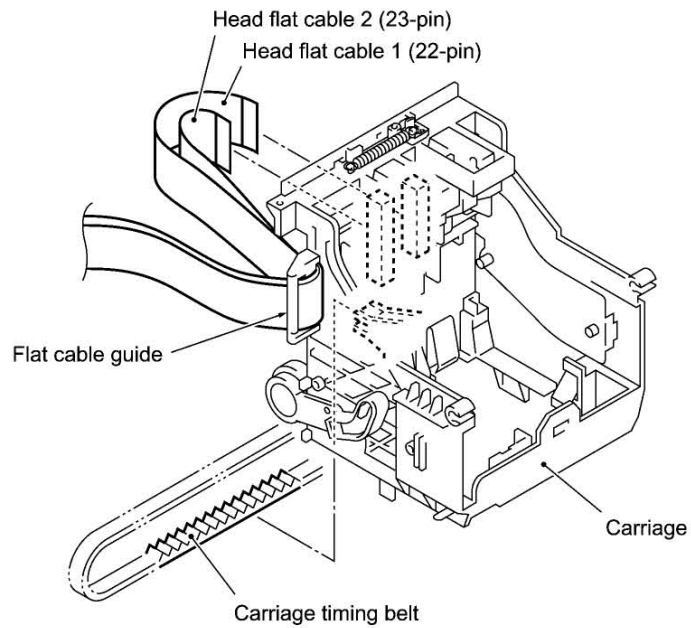

■ Reassembling Notes

- To reinstall the carriage rail, temporarily set the eccentric bushing L to the left side of the main chassis with the screw, align the bushing L with marking made on the main chassis (as shown on page IV-57), and then tighten the screw firmly.

Pass the carriage rail through the opening in the right side of the main chassis and through the carriage, then fit it into the eccentric bushing L.

Next, fit the eccentric bushing R over the right end of the carriage rail, temporarily set the bushing R to the right side of the main chassis with the screw, align the bushing R with marking made on the main chassis, and then tighten the screw firmly.

This alignment with markings is required for keeping the head-platen gap properly.

- If you replace the carriage PCB ASSY, be sure to set the sensing reference levels of the black ink empty sensor (function code: 57). (Refer to Chapter V, Subsection 3.12.)

1.25 Paper Feed Motor, PF Roller Pulley L, PF Timing Belts, Paper Feed Roller, and Paper Ejection Roller

- (1) Unhook the tension spring and remove the screw from the tension plate to release the plate.
- (2) Take off the paper feed motor by removing the two screws. This releases the PF timing belt L from the motor pulley.
- (3) Remove the PF timing belt L from the outer wheel of the PF roller pulley L.
- (4) Remove the PF timing belt S from the ejection roller pulley.
- (5) Remove the retaining ring E8 from the left end of the paper feed roller shaft and pull out the PF roller pulley L. The PF timing belt S also comes off.
- (6) Remove the retaining ring E8 from the paper feed roller shaft inside the main chassis, then slide the paper feed roller to the right and lift it up.
- (7) Remove the ejection roller pulley by pulling its pawl outwards, then slide the paper ejection roller to the right and lift it up.

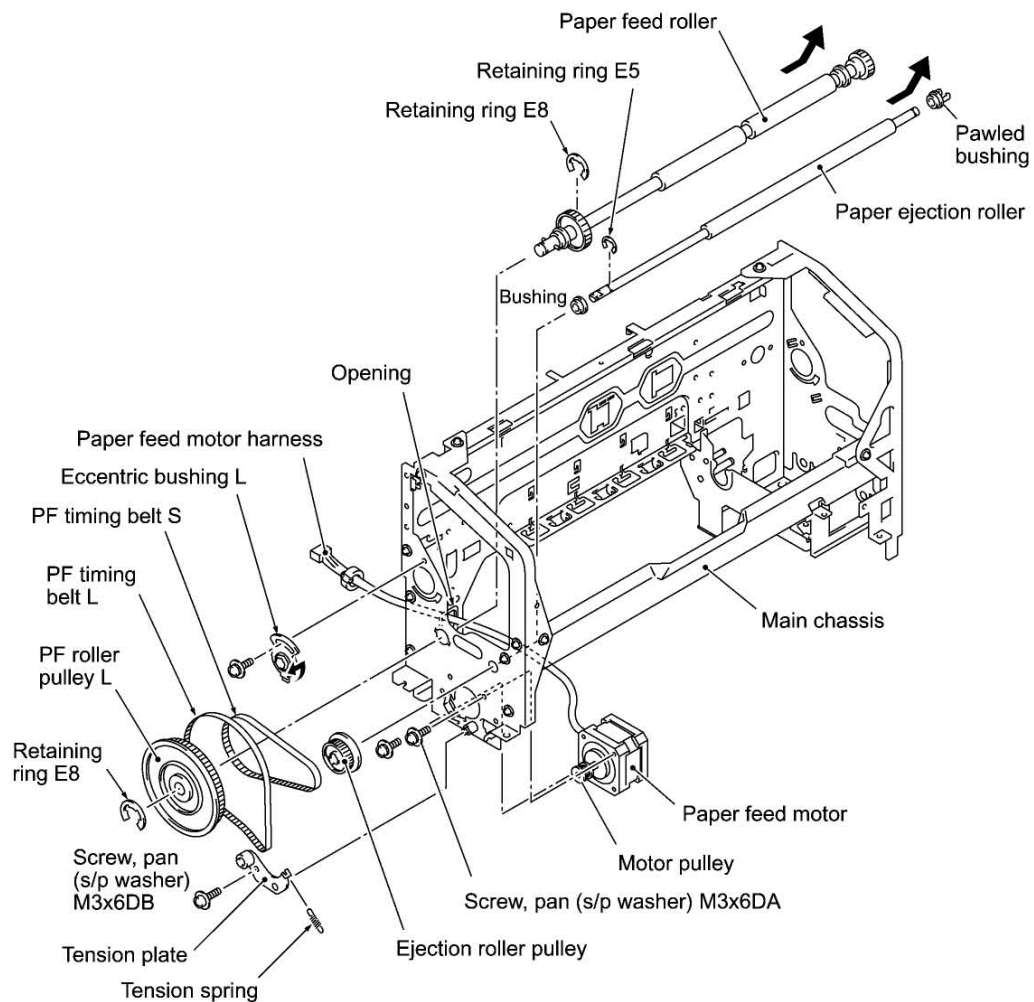

■ Reassembling Notes

- To reassemble the paper feed related parts, follow the steps below.
 - 1) Set the paper ejection roller to the main chassis and snap the ejection roller pulley onto the left end of the roller.
 - 2) Set the paper feed roller to the main chassis and set the retaining ring E8 to its roller shaft inside the main chassis.
 - 3) Put the PF timing belt S around the inner wheel of the PF roller pulley L, then secure the pulley to the left end of the paper feed roller shaft with the retaining ring E8.
 - 4) Put the PF timing belt S around the ejection roller pulley.
 - 5) Put the PF timing belt L around the outer wheel of the PF roller pulley L.
 - 6) Putting the PF timing belt L around the motor pulley, secure the paper feed motor to the main chassis with two screws.
 - 7) Set the tension plate to the main chassis and temporarily tighten the screw (arrow ①).
 - 8) Hook the tension spring onto the tension plate and main chassis to apply tension to the PF timing belt L (arrow ②), and then tighten the screw firmly (arrow ③).

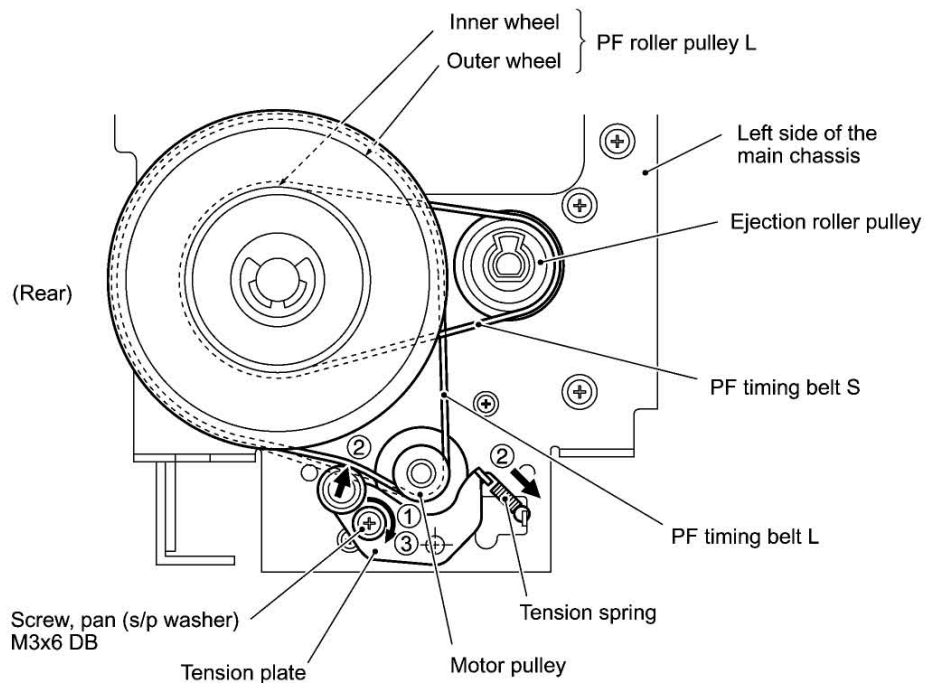

1.26 Harness Routing

Detailed illustrations about sections (A) through (K) are given on the following pages.

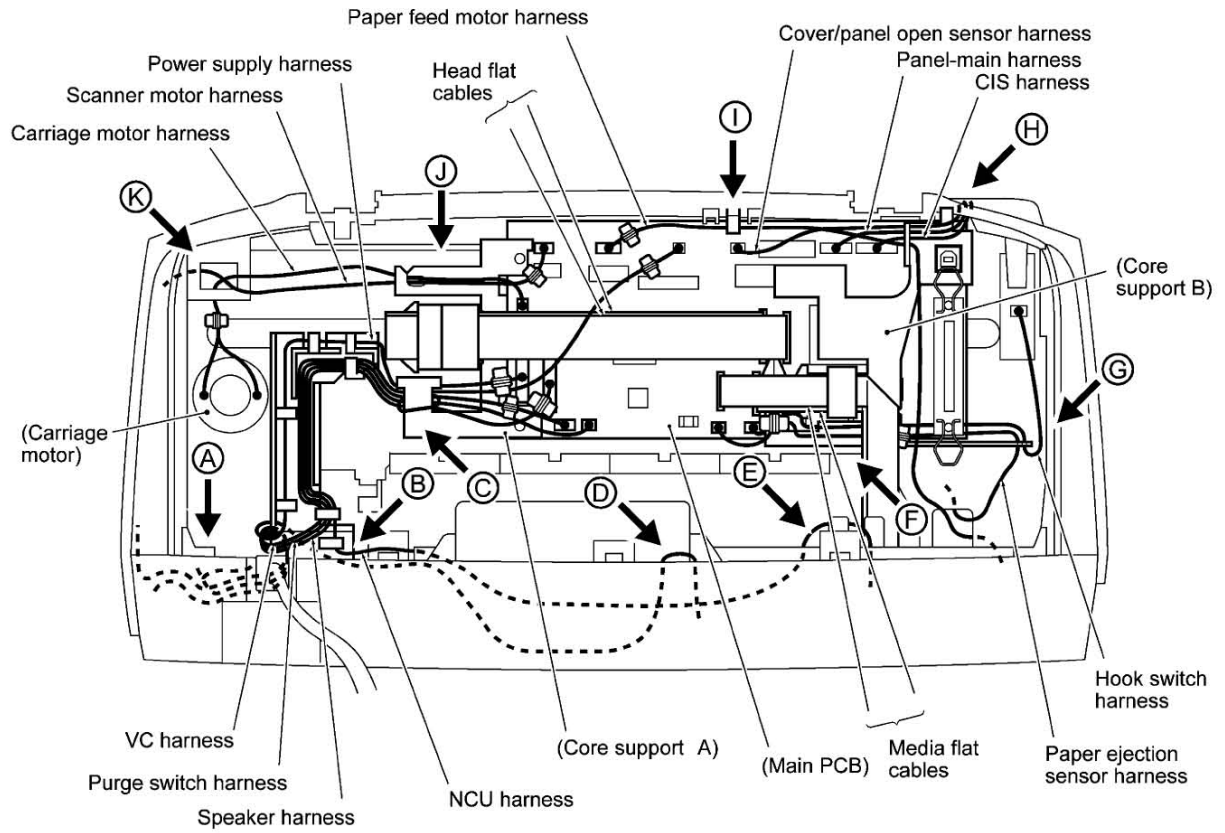

Viewed from the rear

Section A

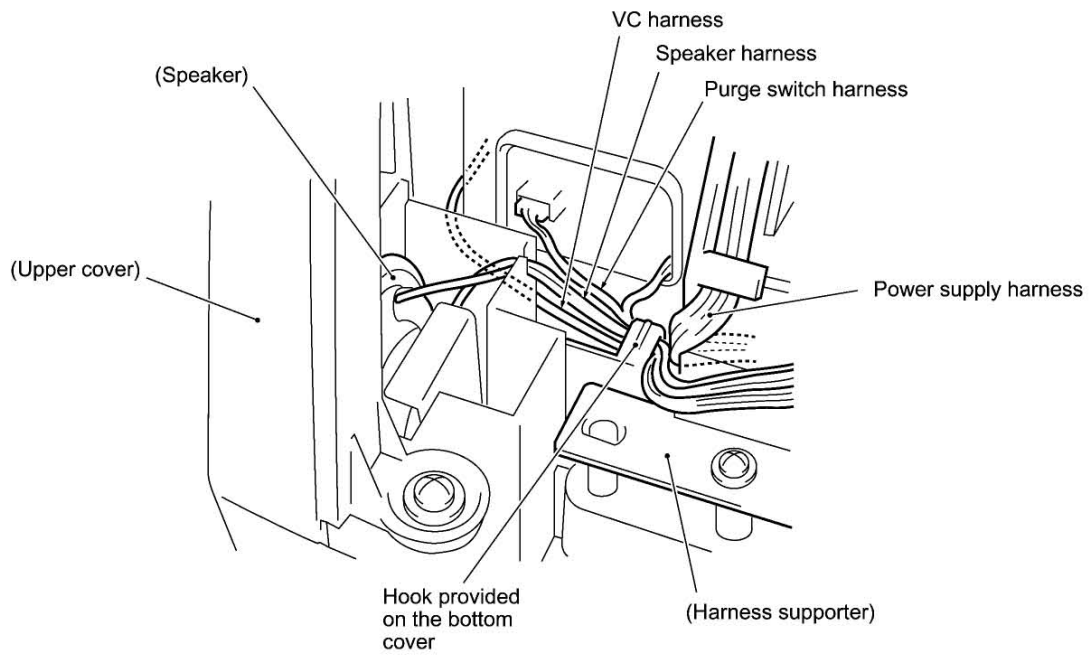

Section B

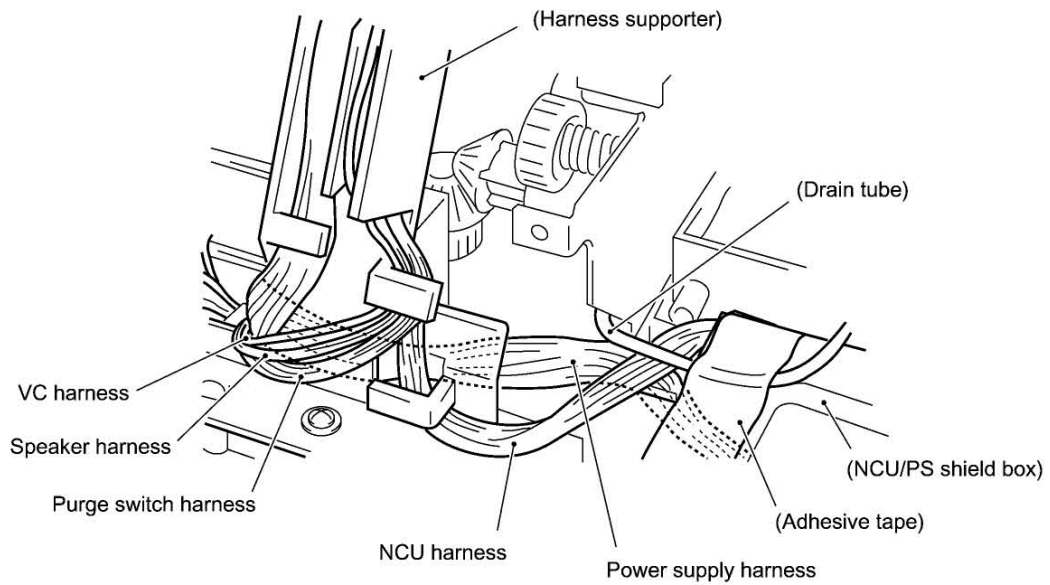

Section C

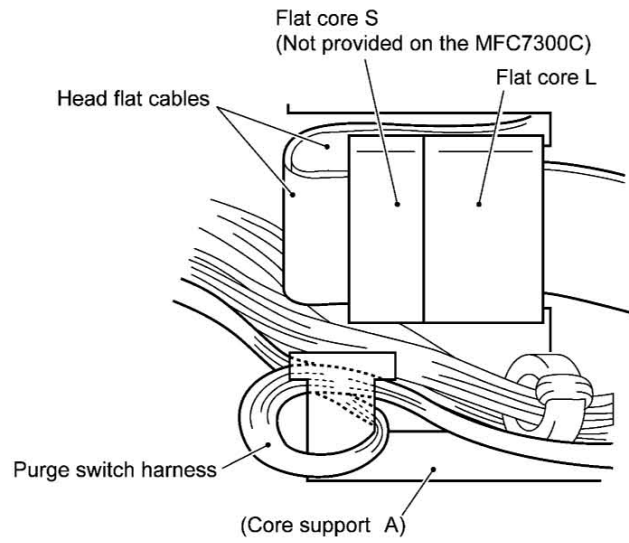

Section D

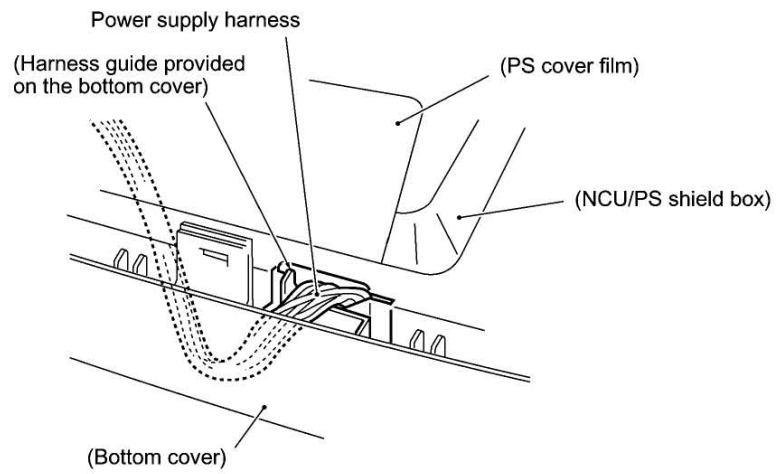

Section E

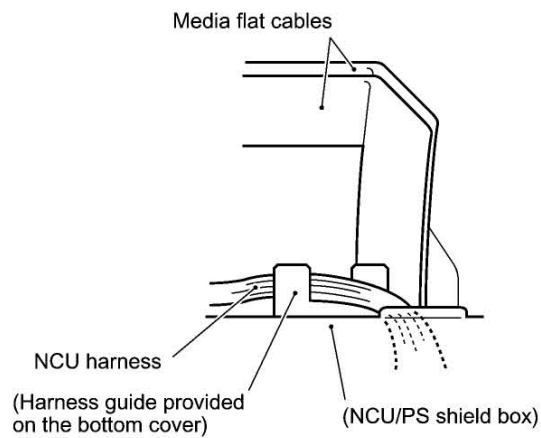

Section F

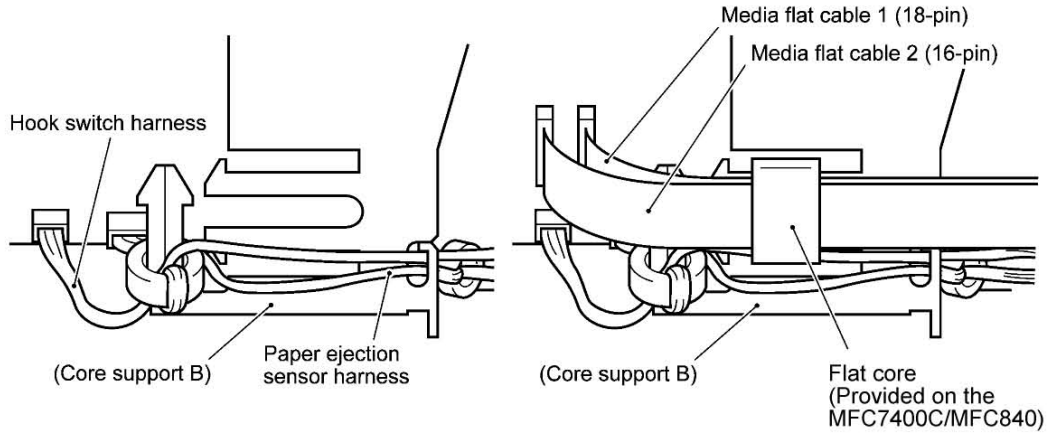

Section G

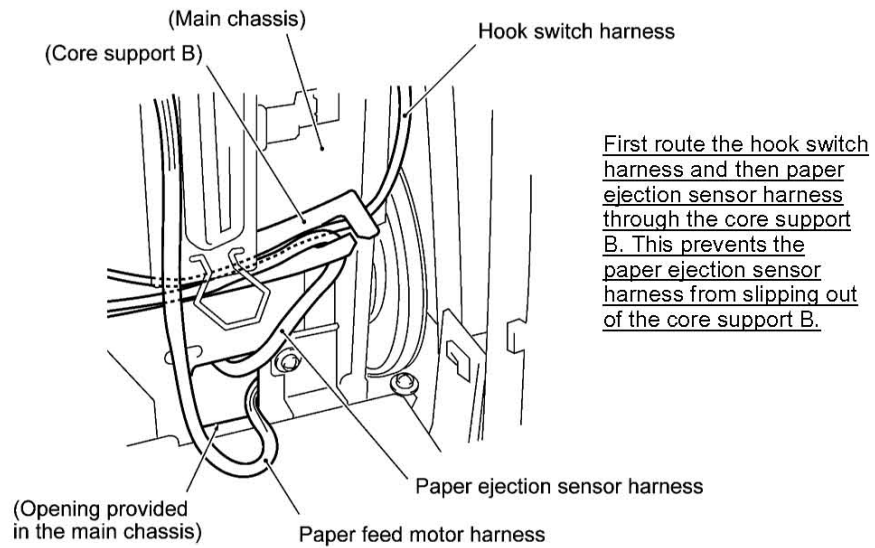

Section H

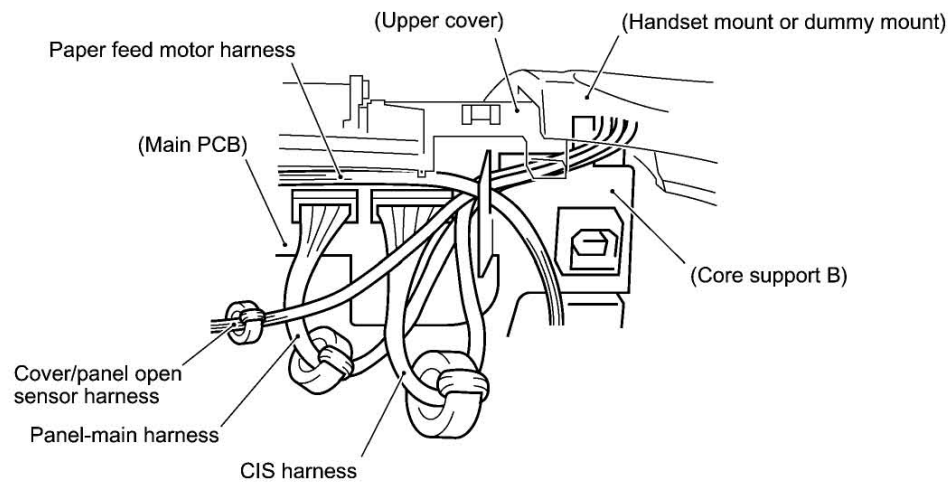

Section I

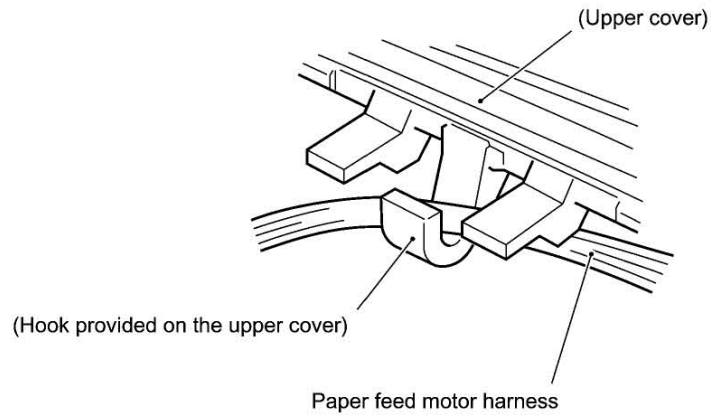

Section J

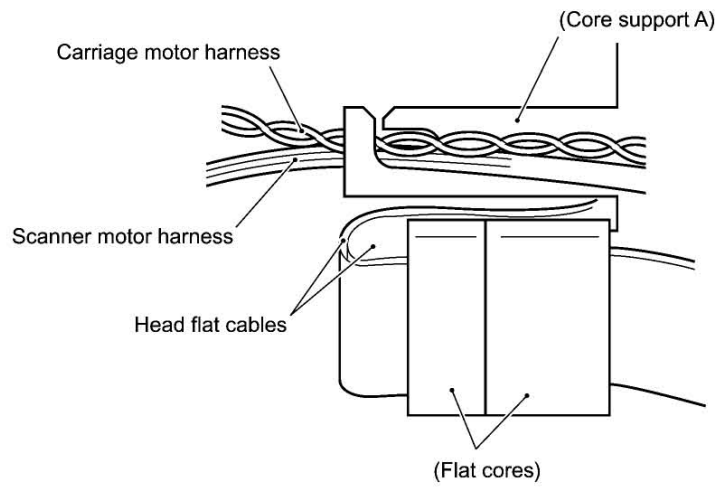

Section K

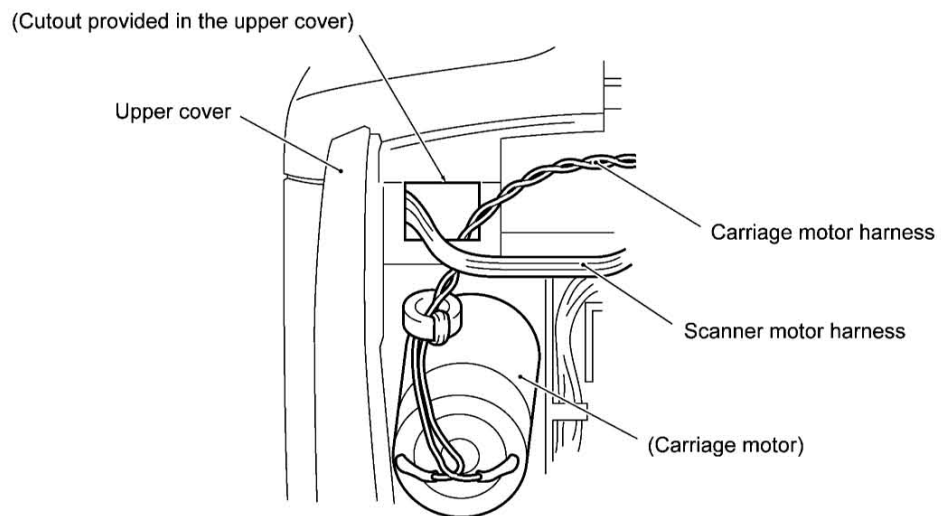

2. LUBRICATION

Apply the following lubricants to the lubrication points as illustrated below.

Lubricant type (Manufacturer)	Lubricant amount		
	0.02cc	Volume of 2 mm dia. ball	Volume of 4 mm dia. ball
Molykote EM-30LG or -30L (Dow Corning)	_____	(EM0.5)	(EM1)
Silicone grease G501 (Shin-etsu Silicone)	_____	_____	(G1)
FLOIL 951P-32 (Kanto Kasei Co., Ltd.)	(GE0.02)	_____	_____

[1] Document feed roller ASSY and document ejection roller ASSY

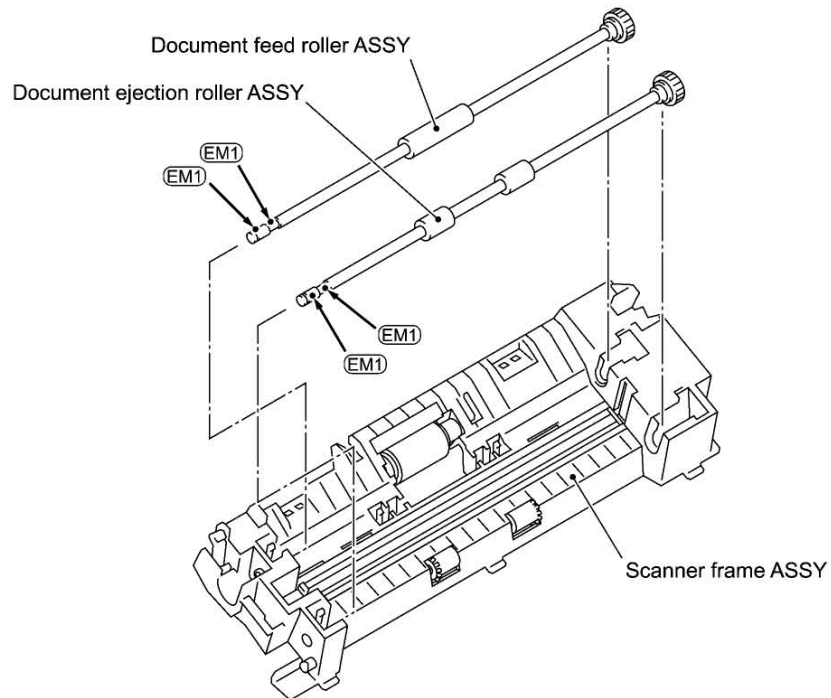

[2] Separation roller and its gear

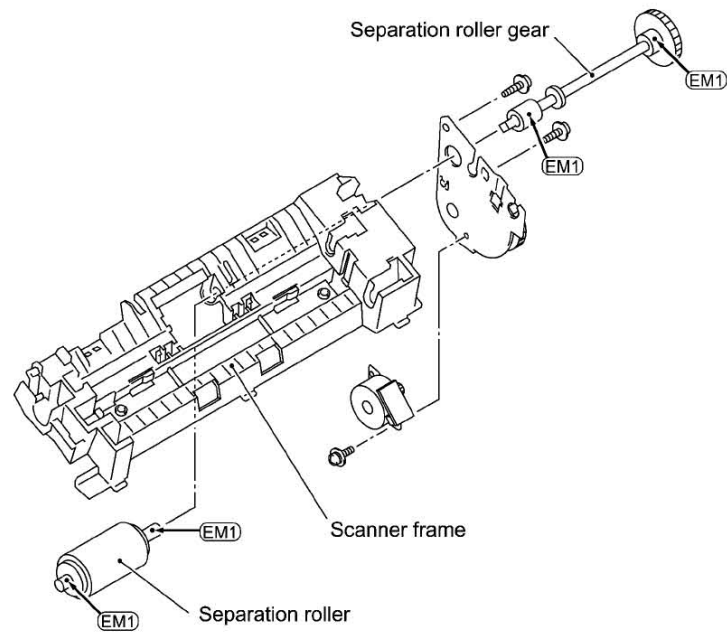

[3] Platen

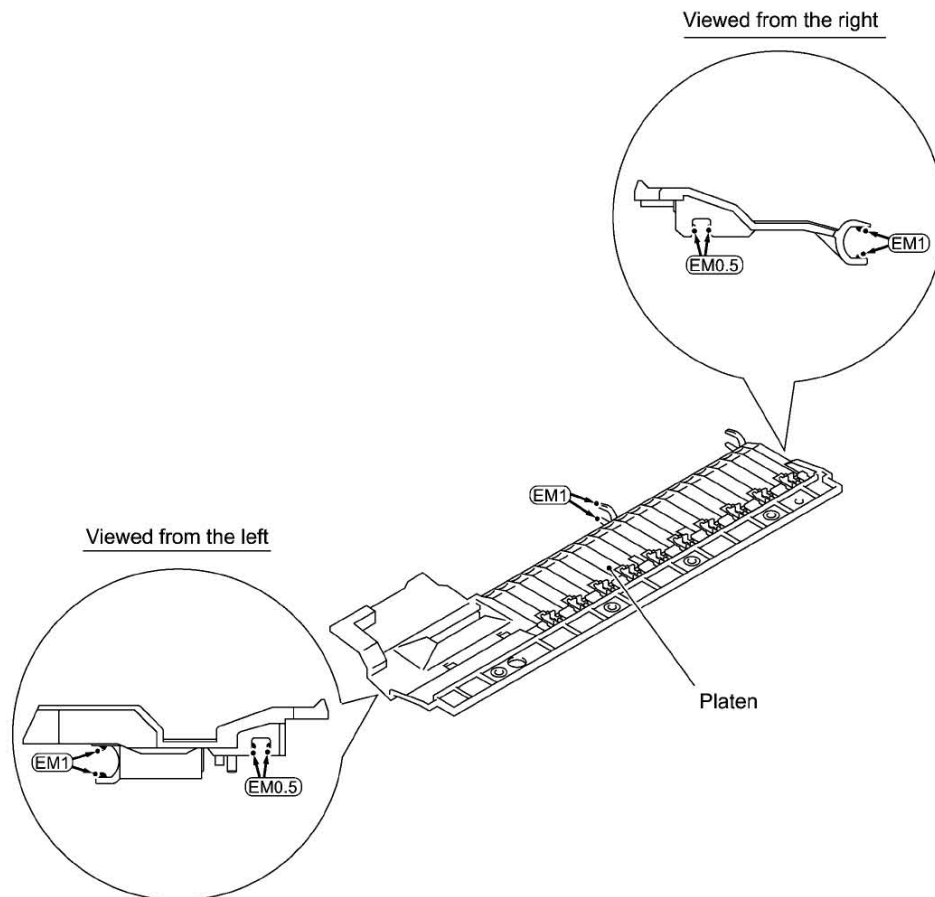

[4] Idle pulley shaft

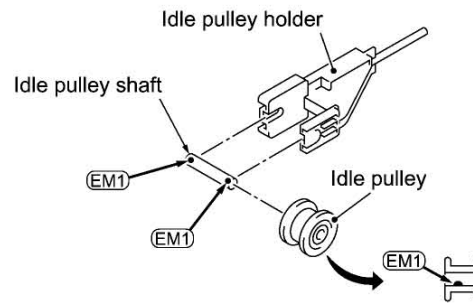

[5] Main chassis and carriage rail

Apply a thin coat of grease EM1 to the inside of the top of the main chassis with a brush inserted through the cutouts.

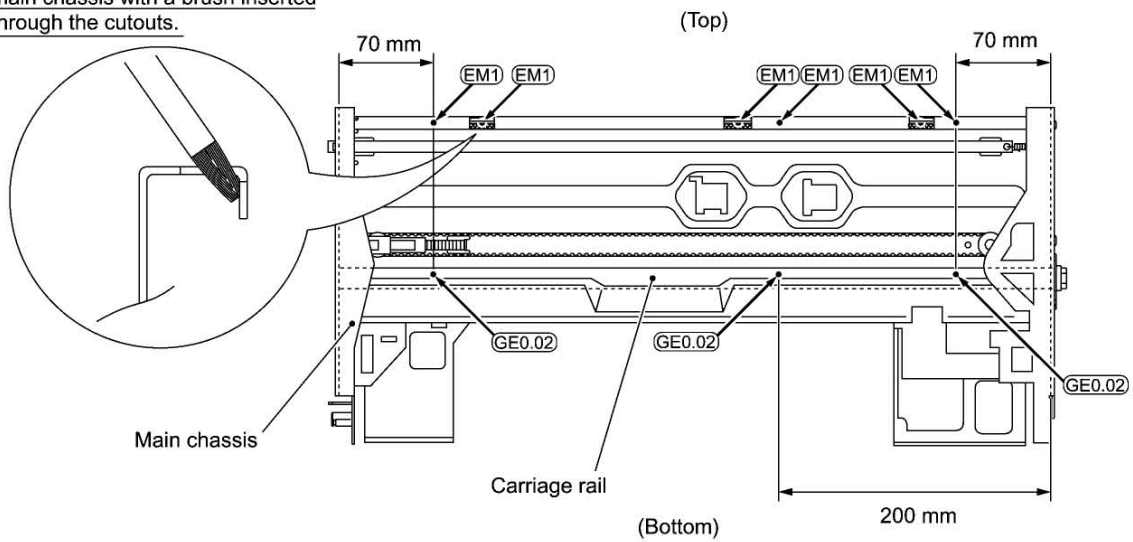

[6] Purge gear 16/18 on the purge unit

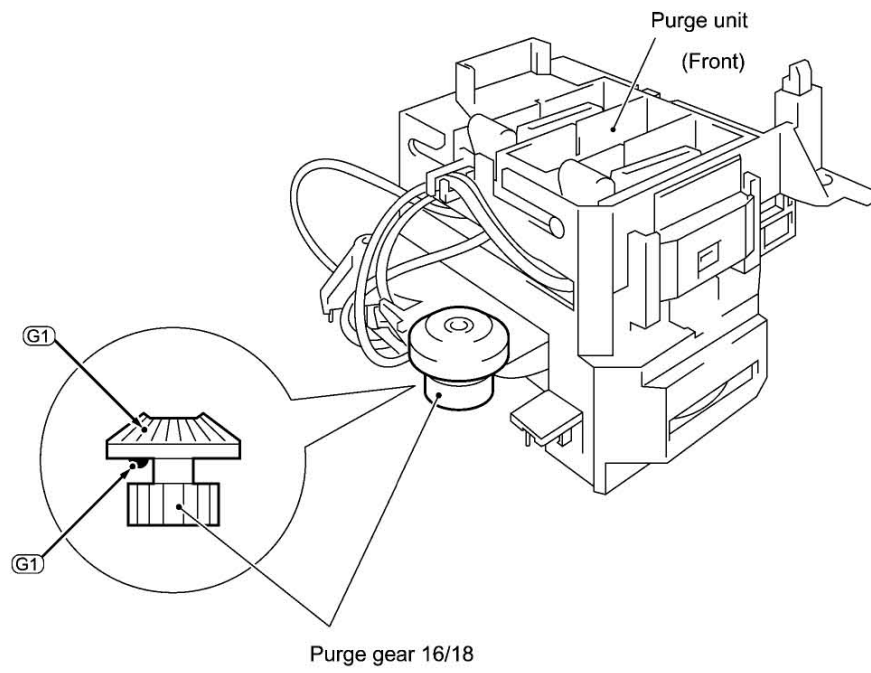

1. ENTRY INTO THE MAINTENANCE MODE

American models: To make the facsimile equipment enter the maintenance mode, press the **Function**, *, **2**, **8**, **6**, and **4** keys in this order.

← Within 2 seconds →

European models: To make the facsimile equipment enter the maintenance mode, press the **Menu**, *, **2**, **8**, **6**, and **4** keys in this order.

← Within 2 seconds →

The equipment beeps for approx. one second and displays " ■■ MAINTENANCE ■■■ " on the LCD, indicating that it is placed in the initial stage of the maintenance mode, a mode in which the equipment is ready to accept entry from the keys.

To select one of the maintenance-mode functions listed in Section 2, enter the corresponding 2-digit function code with the numerical keys on the control panel. (The details of each maintenance-mode function are described in Section 3.)

- NOTES:**
- Pressing the **9** key twice in the initial stage of the maintenance mode makes the equipment exit from the maintenance mode, restoring it to the standby state.
 - Pressing the **Stop** key after entering only one digit restores the equipment to the initial stage of the maintenance mode.
 - If an invalid function code is entered, the equipment resumes the initial stage of the maintenance mode.

2. LIST OF MAINTENANCE-MODE FUNCTIONS

Maintenance-mode Functions

Function Code	Function	Reference Subsection (Page)
01	EEPROM Parameter Initialization	3.1 (V-4)
02	_____	_____
03	_____	_____
04	_____	_____
05	Printout of Scanning Compensation Data	3.2 (V-5)
06	_____	_____
07	_____	_____
08	ADF* Performance Test	3.3 (V-7)
09	Test Pattern 1	3.4 (V-8)
10	Firmware Switch Setting	3.5 (V-9)
11	Printout of Firmware Switch Data	3.5 (V-51)
12	Operational Check of LCD	3.6 (V-52)
13	Operational Check of Control Panel PCB (Check of Keys and Buttons)	3.7 (V-53)
16	Receiver Volume Adjustment	3.8 (V-54)
32	Sensor Operational Check	3.9 (V-55)
54	Fine Adjustment of Scanning Start/End Position	3.10 (V-56)
55	CIS Scanner Area Setting	3.11 (V-57)
57	Setting the Sensing Reference Level of Black Ink Empty Sensor	3.12 (V-58)
62	Setting ID Codes to Facsimile Machines Connected to a PC via USB	3.13 (V-60)
65	Alignment of Vertical Print Lines	3.14 (V-61)
69	Initial Adjustment of PWM Value (Aging of the carriage)	3.15 (V-66)
74	EEPROM Customizing	3.16 (V-66)
82	Equipment Error Code Indication	3.17 (V-67)
87	Output of Transmission Log to the Telephone Line	3.18 (V-67)
91	EEPROM Parameter Initialization (except the telephone number storage area)	3.1 (V-4)
99	Exit from the Maintenance Mode	--- (V-1)
---	Cancellation of the Pin TX Lock Mode (Not applicable to the American models)	3.19 (V-68)

* ADF: Automatic document feeder

----- **IMPORTANT** -----

Basically, the maintenance-mode functions listed on the previous page should be accessed by service personnel only. However, you may allow end users to access some of these under the guidance of service personnel (e.g., by telephone).

The user-accessible functions (codes 10, 11, 12, 82, 87 and 91) are shaded in the table given on the previous page. Function code 10 accesses the firmware switches WSW01 to WSW45, each of which has eight selectors. You should not allow end users to access all of those selectors, but you may allow them to access user-accessible selectors which are shaded in the firmware switch tables in Subsection 3.5.

The service personnel should instruct end users to follow the procedure given below.

(1) American models: Press the **Function** and **Receive Mode** keys in this order.

European models: Press the **Menu** and **Receive Mode** keys in this order.

The LCD clears the current display.

NOTE: The **Receive Mode** key is disabled during standby for redialing and timer.

(2) Press the **0** key.

(3) Enter the desired function code (10, 11, 12, 82, 87, or 91) with the numerical keys.

For function code 10, access the desired firmware switch according to the operating procedure described in Subsection 3.5.

(4) To make the equipment return to the standby state, press the **Stop** key.

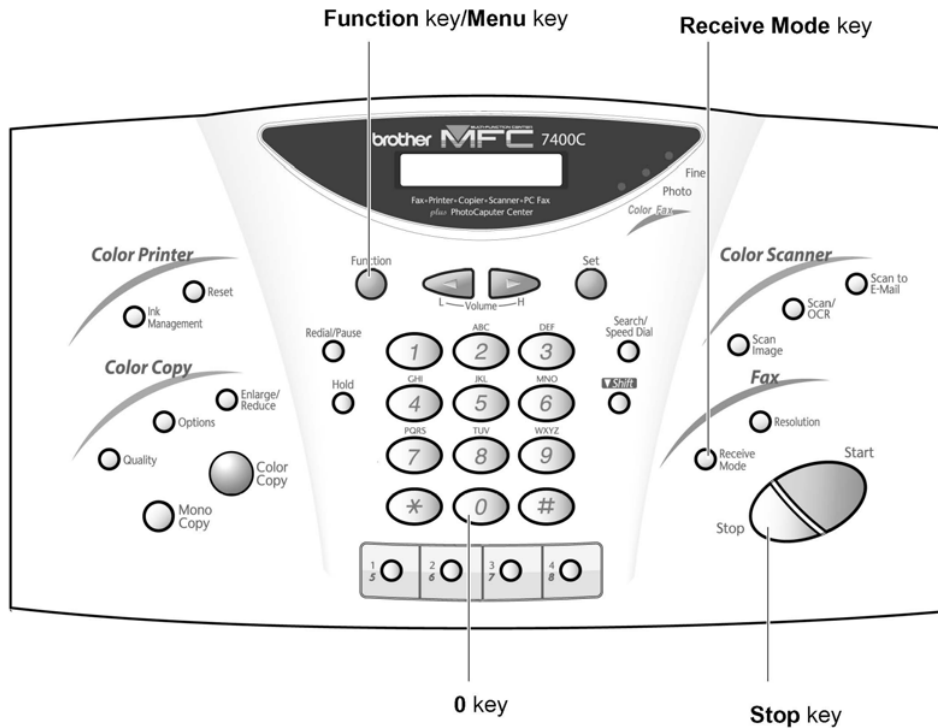

3. DETAILED DESCRIPTION OF MAINTENANCE-MODE FUNCTIONS

3.1 EEPROM Parameter Initialization

■ Function

The equipment initializes the parameters, user switches, and firmware switches registered in the EEPROM, to the initial values. Entering the function code 01 initializes almost all of the EEPROM areas, but entering 91 does not initialize some areas, as listed below.

Function code Data item	01	91
Maintenance-mode functions User switches Firmware switches Remote activation code Activity report	All of these will be Initialized.	These will be initialized
Station ID data Outside line number Telephone function registration One-touch dialing Speed dialing Group dialing		These will <u>not</u> be initialized
EEPROM customizing code (4-digit)	This will <u>not</u> be initialized. (Note that the first digit of the 4-digit code will be initialized to "0." If the code is <u>1</u> 001, for example, it will be initialized to <u>0</u> 001.)	

NOTE: If you replace the main PCB with one used for other facsimile equipment, carry out this procedure and then customize the EEPROM (maintenance-mode function code 74 in Section 3.16).

■ Operating Procedure

- (1) Press the **0** and **1** keys (or the **9** and **1** keys according to your need) in this order in the initial stage of the maintenance mode.
The "PARAMETER INIT" will appear on the LCD.
- (2) Upon completion of parameter initialization, the equipment returns to the initial stage of the maintenance mode.

3.2 Printout of Scanning Compensation Data

■ Function

The equipment prints out the white and black level data for scanning compensation.

■ Operating Procedure

Do not start this function merely after powering on the equipment but start it after carrying out a sequence of scanning operation. Unless the equipment has carried out any scanning operation, this function cannot print out correct scanning compensation data. This is because at the start of scanning operation, the equipment initializes white and black level data and takes in the scanning compensation reference data.

- (1) Press the **0** and **5** keys in this order in the initial stage of the maintenance mode.
The "WHITE LEVEL 1" will appear on the LCD.
- (2) The equipment prints out the scanning compensation data list containing the following:
 - a) White level data for green image (2448 bytes)
 - b) White level data for blue image (2448 bytes)
 - c) White level data for red image (2448 bytes)
 - d) Black level data (2448 bytes)
 - e) A/D converter reference level for high value (1 byte)
 - f) A/D converter reference level for low value (1 byte)
 - g) LED light intensity value for green image (2 bytes)
 - h) LED light intensity value for blue image (2 bytes)
 - i) LED light intensity value for red image (2 bytes)
 - j) LED PWM data (1 byte)
- (3) Upon completion of recording of the compensation data list, the equipment returns to the initial stage of the maintenance mode.

NOTE: When the equipment prints monochrome images after monochrome scanning, only the green data is valid.

NOTE: If any data is abnormal, its code will be printed in inline style, as shown on the next page.

a)
d)

500a0000	: 6c 6a 66 6c 6b 65 60 65 68 6d 73 76 6d 61 6f
500a0020	: 69 6b 71 6f 6d 64 66 6a 71 72 6d 6d 6d 71 68
500a0040	: 6c 6b 6f 6d 6e 64 5a 66 6f 71 69 6d 61 64 6b 70
500a0060	: 6d 70 72 67 50 71 71 6e 76 70 71 63 64 67 70 6f
500a0080	: 6b 75 63 6a 69 79 69 6a 6a 6a 6a 6a 6a 6a 6a 6a
500a00a0	: 69 61 66 60 6d 6b 6c 6c 6c 6c 6c 6c 6c 6c 6c 6c
500a00c0	: 75 6b 65 6f 71 77 72 70 6a 64 67 6f 6d 6d 70 73
500a00e0	: 65 61 6a 64 73 71 71 6a 6b 6d 68 63 73 73 74 6c
500a0100	: 69 69 61 6b 66 66 66 66 66 66 66 66 66 66 66 66
500a0120	: 6a 60 63 73 76 79 6a 6a 6a 6a 6a 6a 6a 6a 6a 6a
500a0140	: 64 6c 6c 6b 69 6d 60 6d 63 63 69 69 67 67 67 67
500a0160	: 66 69 66 64 60 61 69 63 60 6c 6c 67 64 64 68 68
500a0180	: 6b 69 69 69 69 69 69 69 69 69 69 69 69 69 69 69
500a01a0	: 68 61 61 5f 62 64 6c 62 66 66 66 66 66 66 66 66
500a01c0	: 68 64 73 69 69 69 73 69 69 69 69 69 69 69 69 69
500a01e0	: 6f 69 69 6f 6c 69 6f 71 70 69 69 69 69 69 69 69
500a0200	: 70 6a 68 6f 73 6a 79 68 6c 66 61 6d 66 6f 63 67
500a0220	: 69 66 65 69 6a 6d 6c 6c 62 6c 64 6c 6c 6c 6c 6c
500a0240	: 62 60 61 60 67 6a 62 6c 65 68 6a 6a 6a 6a 6a 6a
500a0260	: 69 69 69 72 6a 70 67 6c 65 65 67 68 68 68 68 68
500a0280	: 68 68 6c 6a 70 66 63 60 6a 6e 6e 6e 6e 6e 6e 6e
500a02a0	: 68 66 75 69 64 6b 6c 63 6a 70 68 68 68 68 68 68
500a02c0	: 70 66 6b 63 67 6a 65 65 67 68 67 6b 64 6c 6c 6c
500a02e0	: 6f 66 6f 69 68 68 68 68 68 68 68 68 68 68 68 68
500a0300	: 6f 66 6f 69 68 68 68 68 68 68 68 68 68 68 68 68
500a0320	: 68 66 6c 66 67 69 64 6f 6e 6a 6a 6a 6a 6a 6a 6a
500a0340	: 68 66 6c 66 67 69 64 6f 6e 6a 6a 6a 6a 6a 6a 6a
500a0360	: 69 6c 65 62 63 63 6a 6f 69 65 63 65 64 62 62 62
500a0380	: 44 44 44 44 44 44 44 44 44 44 44 44 44 44 44 44
500a03a0	: 44 44 44 44 44 44 44 44 44 44 44 44 44 44 44 44
500a03c0	: 44 44 44 44 44 44 44 44 44 44 44 44 44 44 44 44
500a03e0	: 44 44 44 44 44 44 44 44 44 44 44 44 44 44 44 44
500a0400	: 44 44 44 44 44 44 44 44 44 44 44 44 44 44 44 44
500a0420	: 44 44 44 44 44 44 44 44 44 44 44 44 44 44 44 44
500a0440	: 44 44 44 44 44 44 44 44 44 44 44 44 44 44 44 44
500a0460	: 44 44 44 44 44 44 44 44 44 44 44 44 44 44 44 44
500a0480	: 44 44 44 44 44 44 44 44 44 44 44 44 44 44 44 44
500a04a0	: 44 44 44 44 44 44 44 44 44 44 44 44 44 44 44 44
500a04c0	: 44 44 44 44 44 44 44 44 44 44 44 44 44 44 44 44
500a04e0	: 44 44 44 44 44 44 44 44 44 44 44 44 44 44 44 44
500a0500	: 44 44 44 44 44 44 44 44 44 44 44 44 44 44 44 44
500a0520	: 44 44 44 44 44 44 44 44 44 44 44 44 44 44 44 44
500a0540	: 44 44 44 44 44 44 44 44 44 44 44 44 44 44 44 44
500a0560	: 44 44 44 44 44 44 44 44 44 44 44 44 44 44 44 44
500a0580	: 44 44 44 44 44 44 44 44 44 44 44 44 44 44 44 44
500a05a0	: 44 44 44 44 44 44 44 44 44 44 44 44 44 44 44 44
500a05c0	: 44 44 44 44 44 44 44 44 44 44 44 44 44 44 44 44
500a05e0	: 44 44 44 44 44 44 44 44 44 44 44 44 44 44 44 44
500a0600	: 44 44 44 44 44 44 44 44 44 44 44 44 44 44 44 44
500a0620	: 44 44 44 44 44 44 44 44 44 44 44 44 44 44 44 44
500a0640	: 44 44 44 44 44 44 44 44 44 44 44 44 44 44 44 44
500a0660	: 44 44 44 44 44 44 44 44 44 44 44 44 44 44 44 44
500a0680	: 44 44 44 44 44 44 44 44 44 44 44 44 44 44 44 44
500a06a0	: 44 44 44 44 44 44 44 44 44 44 44 44 44 44 44 44
500a06c0	: 44 44 44 44 44 44 44 44 44 44 44 44 44 44 44 44
500a06e0	: 44 44 44 44 44 44 44 44 44 44 44 44 44 44 44 44
500a0700	: 44 44 44 44 44 44 44 44 44 44 44 44 44 44 44 44
500a0720	: 44 44 44 44 44 44 44 44 44 44 44 44 44 44 44 44
500a0740	: 44 44 44 44 44 44 44 44 44 44 44 44 44 44 44 44
500a0760	: 44 44 44 44 44 44 44 44 44 44 44 44 44 44 44 44
500a0780	: 44 44 44 44 44 44 44 44 44 44 44 44 44 44 44 44
500a07a0	: 44 44 44 44 44 44 44 44 44 44 44 44 44 44 44 44
500a07c0	: 44 44 44 44 44 44 44 44 44 44 44 44 44 44 44 44
500a07e0	: 44 44 44 44 44 44 44 44 44 44 44 44 44 44 44 44
500a0fe0	: 14 0e 0f 15 15 14 1c 12 11 16 13 14 14 14 15 13
500a17e0	: 63 65 69 6d 67 65 67 68 68 68 64 65 64 68 66
500a27e0	: 13 0d 0f 14 15 13 1b 12 11 16 13 10 14 13 15 12
500a37e0	: 60 63 67 6b 65 64 61 62 64 64 61 61 69 60 63 60
500a3fe0	: 13 0d 0f 14 15 13 1b 12 10 15 13 11 14 13 15 12
500a4fe0	: 12 12 16 19 13 14 12 14 15 14 0f 0e 17 11 12 12
500a57e0	: 10 0a 0a 10 11 0f 17 0e 0d 13 10 0d 11 10 12 0f

500a5800	: 14 11 0c 0d 11 0c 15 0d 11 11 10 13 11 08 0e 0f
500a5820	: 15 10 15 16 13 12 12 11 0b 0f 0e 0f 11 12 0f 13 19
500a5840	: 19 16 15 12 1a 15 11 12 12 17 0e 12 11 0e 18 11
500a5860	: 0b 0d 0d 0e 17 10 12 0f 14 0f 10 0e 13 18 0d 12
500a5880	: 10 11 16 0d 11 12 11 12 14 12 0d 11 17 0f 11 14
500a58a0	: 16 0d 10 0f 10 12 12 0e 0b 15 0e 0d 0c 13 13 12
500a58c0	: 12 14 15 16 10 0e 12 10 12 12 12 0e 12 0d 13 12
500a58e0	: 0a 10 10 10 12 11 15 0f 11 16 12 0f 11 0b 17 0c
500a5900	: 0b 13 14 0c 0f 0e 0c 0d 0c 13 0c 0c 0c 0b 0c 0e
500a5920	: 12 0c 12 12 0f 15 13 0d 22 14 1b 12 15 16 0f 0f
500a5940	: 13 13 16 13 13 15 0d 13 16 0b 0e 10 0f 12 15 11
500a5960	: 10 10 13 15 14 13 18 15 0f 10 0f 11 15 19 14 14
500a5980	: 15 1a 1c 13 1a 15 1a 19 14 10 17 15 14 0f 15 0f
500a59a0	: 0f 12 13 17 13 11 14 19 14 1a 10 0e 12 14 0f 17
500a59c0	: 10 12 0c 17 16 09 15 11 14 11 1a 11 0e 0e 0c 10
500a59e0	: 10 15 11 13 13 11 0f 12 0b 0d 11 11 11 0d 14 10
500a5a00	: 0e 0c 0e 14 0f 10 0e 11 17 0f 11 14 0a 13 11 17
500a5a20	: 0f 11 11 11 0d 14 0f 12 10 0c 0c 0f 10 0e 15 0e
500a5a40	: 0f 0f 12 0a 0f 0c 0c 0d 05 09 13 0e 10 11 0e 0c
500a5a60	: 15 0e 15 14 15 0f 15 11 10 0e 17 12 14 19 10 10
500a5a80	: 0f 16 13 11 17 15 1c 13 16 15 17 17 0f 16 18 20
500a5aa0	: 16 17 14 14 17 1f 0e 14 14 11 14 17 13 14 12
500a5ac0	: 16 13 17 17 15 16 11 16 12 14 1a 14 1b 0e 11 11
500a5ae0	: 10 15 10 15 15 11 16 16 14 15 17 14 15 0e 0f 17

- e) 40058076 : d8
- f) 40058079 : 84
- g) 4005807c : 04c5
- h) 4005807e : 039f
- i) 40058080 : 05d5
- j) 40058086 : 4b

Scanning Compensation Data List

3.3 ADF Performance Test

■ Function

The equipment counts the documents fed by the automatic document feeder (ADF) and displays the count on the LCD for checking the ADF performance.

■ Operating Procedure

- (1) Set documents. (Allowable up to the ADF capacity.)

The "DOC. READY" will appear on the LCD.

- (2) Press the **0** and **8** keys in this order.

While counting the documents, the equipment feeds them in and out, displaying the current count on the LCD as shown below.

ADF CHECK P.01

↑ Current count (1st page in this example)

- (3) After showing the final count, the equipment beeps for one second. To return the equipment to the initial stage of the maintenance mode, press the **Stop** key.

3.4 Test Pattern 1

■ Function

This function, much like the copying function, prints out test pattern 1 to allow the service personnel to check for record data missing or print quality.

■ Operating Procedure

Press the **0** and **9** keys in this order in the initial stage of the maintenance mode.

The figure below shows test pattern 1.

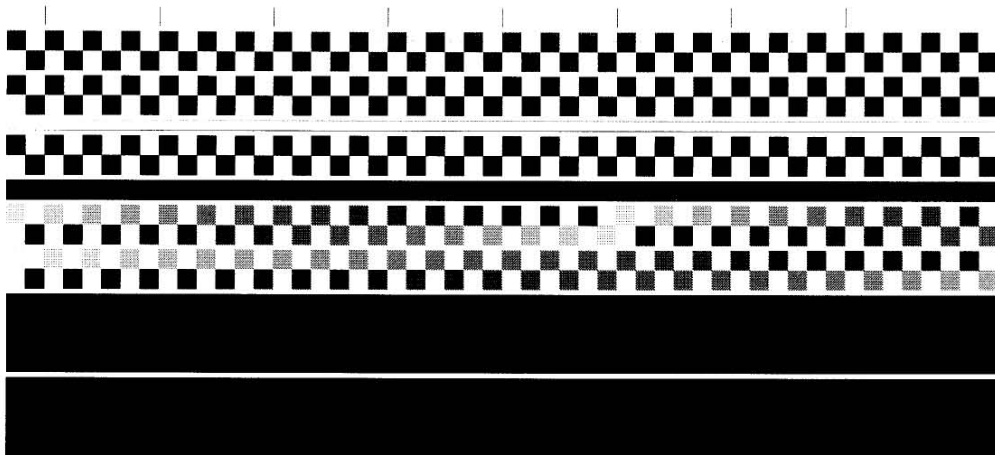

Test Pattern 1

3.5 Firmware Switch Setting and Printout

[A] Firmware switch setting

■ Function

The facsimile equipment incorporates the following firmware switch functions (WSW01 through WSW45) which may be activated with the procedures using the control panel keys and buttons. The firmware switches have been set at the factory in conformity to the communications standards and codes of each country. Do not disturb them unless necessary. Some firmware switches may not be applicable in some versions. The firmware switch data list indicates "Not used." for those inapplicable switches.

Firmware Switches (WSW01 through WSW45)

WSW No.	Function	Reference Page
WSW01	Dial pulse setting	V-11
WSW02	Tone signal setting	V-12
WSW03	PABX mode setting	V-13
WSW04	TRANSFER facility setting	V-15
WSW05	1st dial tone and busy tone detection	V-16
WSW06	Pause key setting and 2nd dial tone detection	V-18
WSW07	Dial tone setting 1	V-20
WSW08	Dial tone setting 2	V-21
WSW09	Protocol definition 1	V-22
WSW10	Protocol definition 2	V-23
WSW11	Busy tone setting	V-24
WSW12	Signal detection condition setting	V-25
WSW13	Modem setting	V-26
WSW14	AUTO ANS facility setting	V-27
WSW15	REDIAL facility setting	V-28
WSW16	Function setting 1	V-29
WSW17	Function setting 2	V-30
WSW18	Function setting 3	V-31
WSW19	Transmission speed setting	V-32
WSW20	Overseas communications mode setting	V-33
WSW21	TAD setting 1	V-34
WSW22	ECM and copy resolution setting	V-35
WSW23	Communications setting	V-36
WSW24	TAD setting 2	V-37
WSW25	TAD setting 3	V-38
WSW26	Function setting 4	V-39
WSW27	Function setting 5	V-40
WSW28	Function setting 6	V-41
WSW29	Function setting 7	V-42
WSW30	Not used.	V-43
WSW31	Function setting 9	V-43
WSW32	Function setting 10	V-44
WSW33	Function setting 11	V-45
WSW34	Function setting 12	V-46
WSW35	Not used.	V-46
WSW36	Function setting 14	V-47

Firmware Switches (WSW01 through WSW45) *Continued*

WSW No.	Function	Reference Page
WSW37	Function setting 15	V-48
WSW38	Not used.	V-48
WSW39	Not used.	V-48
WSW40	Not used.	V-48
WSW41	Not used.	V-48
WSW42	Function setting 20	V-49
WSW43	Function setting 21	V-49
WSW44	Not used.	V-50
WSW45	Not used.	V-50

■ **Operating Procedure**

- (1) Press the **1** and **0** keys in this order in the initial stage of the maintenance mode.
The equipment displays the "WSW00" on the LCD and becomes ready to accept a firmware switch number.
- (2) Enter the desired number from the firmware switch numbers (01 through 45).

The following appears on the LCD:

WSWXX = 00000000
 ↑ ↑
 Selector No. 1 Selector No. 8

- (3) Use the ◀ or ▶ keys to move the cursor to the selector position to be modified.
- (4) Enter the desired number using the **0** and **1** keys.
- (5) Press the **Set** key. This operation saves the newly entered selector values onto the EEPROM and readies the equipment for accepting a firmware switch number.
- (6) Repeat steps (2) through (5) until the modification for the desired firmware switches is completed.
- (7) Press the **Set** or **Stop** key to return the equipment to the initial stage of the maintenance mode.

- NOTES:**
- To cancel this operation and return the equipment to the initial stage of the maintenance mode during the above procedure, press the **Stop** key.
 - If there is a pause of more than one minute after a single-digit number is entered for double-digit firmware switch numbers, the equipment will automatically return to the initial stage of the maintenance mode.

■ **Note**

The user-accessible selectors of the firmware switches are shaded in the tables given on the following pages.

■ **Detailed Description for the Firmware Switches**

WSW01 (Dial pulse setting)

Selector No.	Function	Setting and Specifications
1 2	Dial pulse generation mode	No. 1 2 0 0 : N 0 1 : N+1 1 0 : 10-N 1 1 : N
3 4	Break time length in pulse dialing	No. 3 4 0 0 : 60 ms 0 1 : 67 ms 1 0 : 40 ms (for 16 PPS) 1 1 : 64 ms (at 106-ms intervals)
5 6	Inter-digit pause	No. 5 6 0 0 : 800 ms 0 1 : 850 ms 1 0 : 950 ms 1 1 : 600 ms
7	Switching between pulse (DP) and tone (PB) dialing, by the function switch	0: Yes 1: No
8	Default dialing mode, pulse (DP) or tone (PB) dialing	0: PB 1: DP

● **Selectors 1 and 2: Dial pulse generation mode**

These selectors set the number of pulses to be generated in pulse dialing.

N: Dialing "N" generates "N" pulses. (Dialing "0" generates 10 pulses.)

N + 1: Dialing "N" generates "N + 1" pulses.

10 - N: Dialing "N" generates "10 - N" pulses.

● **Selectors 3 and 4: Break time length in pulse dialing**

These selectors set the break time length in pulse dialing.

(Example: If "1," "2," and "3" are dialed when N is set by selectors 1 and 2.)

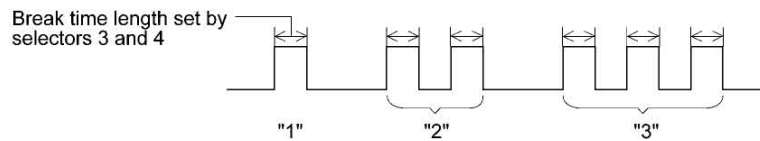

● **Selectors 5 and 6: Inter-digit pause**

These selectors set the inter-digit pause in pulse dialing.

(Example: If "1," "2," and "3" are dialed when N is set by selectors 1 and 2.)

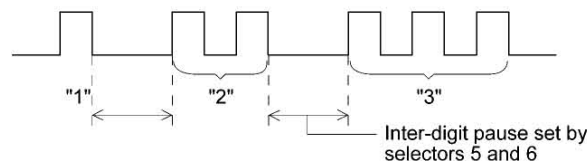

- **Selector 7: Switching between pulse (DP) and tone (PB) dialing, by the function switch**

This selector determines whether or not the dialing mode may be switched between the pulse (DP) and tone (PB) dialing by using the function switch.

- **Selector 8: Default dialing mode, pulse (DP) or tone (PB) dialing**

This selector sets the default dialing mode (pulse dialing or tone dialing) which may be changed by the function switch. If the user switches it with the function switch when selector 7 is set to "0," the setting specified by this selector will also be switched automatically.

WSW02 (Tone signal setting)

Selector No.	Function	Setting and Specifications
1 2	Tone signal transmission time length	No. 1 2 0 0 : 70 ms 0 1 : 80 ms 1 0 : 90 ms 1 1 : 100 ms
3 4	Min. pause in tone dialing	No. 3 4 0 0 : 70 ms 0 1 : 80 ms 1 0 : 90 ms 1 1 : 140 ms
5 8	Attenuator for pseudo ring backtone to the line (selectable in the range of 0-15 dB)	0: 0 dB 1: 8 dB 0: 0 dB 1: 4 dB 0: 0 dB 1: 2 dB 0: 0 dB 1: 1 dB

- **Selectors 1 through 4: Tone signal transmission time length and Min. pause in tone dialing**

These selectors set the tone signal transmission time length and minimum pause in tone dialing.

(Example: If "1," "2," "3," "4," and "5" are dialed.)

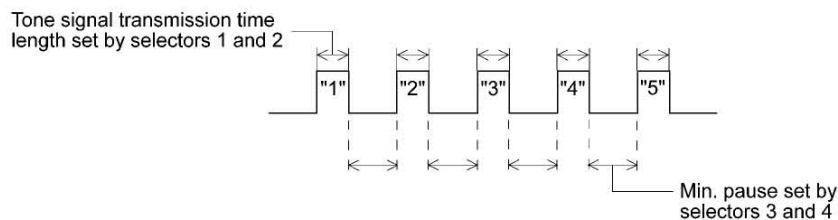

- **Selectors 5 through 8: Attenuator for pseudo ring backtone to the line**

These selectors are used to adjust the sound level of beep generated as a ring backtone in the F/T mode or as a signal during remote control operation or at the start of ICM recording.

Setting two or more selectors to "1" produces addition of attenuation assigned to each selector.

WSW03 (PABX* mode setting)

Selector No.	Function	Setting and Specifications
1	CNG detection when sharing a modular wall socket with a telephone	0: A 1: B
2 4	Min. detection time length of PABX* dial tone, required for starting dialing	No. 2 3 4 0 0 0 : 50 ms 0 0 1 : 210 ms 0 1 0 : 500 ms 0 1 1 : 800 ms 1 0 0 : 900 ms 1 0 1 : 1.5 sec. 1 1 0 : 2.0 sec. 1 1 1 : 2.5 sec.
5	CNG detection when sharing a modular wall socket with a telephone	0: A 1: B
6 7	Dial tone detection in PABX*	No. 6 7 0 0 : No detection (3.5 sec. WAIT) 0 1 : No detection (5 sec. WAIT) 1 0 : No detection (7 sec. WAIT) 1 1 : Detection (Frequency only)
8	Not used.	

* PABX: Private automatic branch exchange

NOTE: Selectors 2 through 4, 6 and 7 are not applicable where no PABX is installed.

● **Selectors 1 and 5: CNG detection when sharing a modular wall socket with a telephone**

These selectors determine whether or not the equipment detects a CNG signal when a line is connected to a telephone sharing a modular wall socket with the equipment. Upon detection of CNG signals by the number of cycles specified by these selectors, the equipment interprets CNG as an effective signal and then starts FAX reception.

Selector No.		Cycle
1	5	
0 (A)	0 (A)	0.5 cycle
0 (A)	1 (B)	1.0 cycle
1 (B)	0 (A)	1.5 cycles
1 (B)	1 (B)	2.0 cycles

● **Selectors 2 through 4: Min. detection time length of PABX dial tone, required for starting dialing**

Upon detection of the PABX dial tone for the time length set by these selectors, the equipment starts dialing.

These selectors are effective only when both selectors 6 and 7 are set to "1" (Detection).

- **Selectors 6 and 7: Dial tone detection in PABX**

These selectors activate or deactivate the dial tone detection function which detects a dial tone when a line is connected to the PABX.

Setting both of these selectors to "1" activates the dial tone detection function so that the equipment starts dialing upon detection of a dial tone when a line is connected.

Other setting combinations deactivate the dial tone detection function so that the equipment starts dialing after the specified WAIT (3.5, 5.0, or 7.0 sec.) without detection of a dial tone when a line is connected.

WSW04 (TRANSFER facility setting)

Selector No.	Function	Setting and Specifications
1	Earth function in transfer facility	0: Provided 1: Not provided
2 4	Not used.	
5 6	Earth time length for earth function	No. 5 6 0 0 : 200 ms 0 1 : 300 ms 1 0 : 500 ms 1 1 : 700 ms
7 8	Break time length for flash function	No. 7 8 0 0 : 80 ms 0 1 : 110 ms 1 0 : 250 ms 1 1 : 500 ms

NOTE: Selectors 1 and 5 through 8 are not applicable in those countries where no transfer facility is supported.

- **Selector 1: Earth function in transfer facility**

This selector determines whether or not the earth function is added to the transfer setting menu to be accessed by the function switch.

- **Selectors 5 and 6: Earth time length for earth function**

These selectors set the short-circuiting time length of the telephone line (La or Lb) to ground. This setting is effective only when the earth function is selected for the R key by using the function switch.

- **Selectors 7 and 8: Break time length for flash function**

These selectors set the break time length. This setting is effective only when the flash function is selected for the Speed Dial key by using the function switch.

WSW05 (1st dial tone and busy tone detection)

Selector No.	Function	Setting and Specifications
1 3	1st dial tone detection	No. 1 2 3 0 0 0 : 3.5 sec. WAIT 0 0 1 : 7.0 sec. WAIT 0 1 0 : 10.5 sec. WAIT 0 1 1 : 14.0 sec. WAIT 1 0 0 : 17.5 sec. WAIT 1 0 1 : 21.0 sec. WAIT 1 1 0 : 24.5 sec. WAIT 1 1 1 : Detection (Without WAIT)
4	Max. pause time allowable for remote ID code detection	0 : 2 seconds 1: 1 second
5 6	Busy tone detection in automatic sending mode	No. 5 6 0 0 : No detection 0 1 : Detection only after dialing 1 0 : No detection 1 1 : Detection before and after dialing
7	Busy tone detection in automatic receiving mode	0: Yes 1: No
8	Not used.	

NOTE: Selectors 5 through 7 are not applicable in those countries where no busy tone detection is supported.

- **Selectors 1 through 3: 1st dial tone detection**

These selectors activate or deactivate the 1st dial tone detection function which detects the 1st dial tone issued from the PSTN when a line is connected to the PSTN.

Setting all of these selectors to "1" activates the dial tone detection function so that the equipment starts dialing upon detection of a dial tone when a line is connected. (However, in those countries which support no dial tone detection function, e.g., in the U.S.A., setting these selectors to "1" makes the equipment start dialing after a WAIT of 3.5 seconds.) For the detecting conditions of the 1st dial tone, refer to WSW07 and WSW08.

Other setting combinations deactivate the dial tone detection function so that the equipment starts dialing after the specified WAIT (3.5, 7.0, 10.5, 14.0, 17.5, 21.0, or 24.5 seconds) without detection of a dial tone when a line is connected to the PSTN.

- **Selector 4: Max. pause time allowable for remote ID code detection**

This selector sets the maximum pause time allowable for detecting the second digit of a remote ID code after detection of the first digit in remote reception.

If selector 4 is set to "0" (2 seconds), for instance, only a remote ID code whose second digit is detected within 2 seconds after detection of the first digit will become effective so as to activate the remote function.

- **Selectors 5 and 6: Busy tone detection in automatic sending mode**

These selectors determine whether or not the equipment automatically disconnects a line upon detection of a busy tone in automatic sending mode.

Setting selector 6 to "0" ignores a busy tone so that the equipment does not disconnect the line.

Setting selectors 5 and 6 to "0" and "1," respectively, makes the equipment detect a busy tone only after dialing and disconnect the line.

Setting both of selectors 5 and 6 to "1" makes the equipment detect a busy tone before and after dialing and then disconnect the line.

- **Selector 7: Busy tone detection in automatic receiving mode**

This selector determines whether or not the equipment automatically disconnects the line upon detection of a busy tone in automatic receiving mode.

WSW06 (Pause key setting and 2nd dial tone detection)

Selector No.	Function	Setting and Specifications
1 3	Pause key setting and 2nd dial tone detection	No. 1 2 3 0 0 0 : No pause 0 0 1 : 3.5 sec. WAIT 0 1 0 : 7 sec. WAIT 0 1 1 : 10.5 sec. WAIT 1 0 0 : 14 sec. WAIT 1 1 0 : 2nd dial tone detection only in pulse dialing (DP) system 1 0 1 : } 2nd dial tone detection 1 1 1 : } both in DP and push-button (PB) dialing system
4 6	Detection of international tone	No. 4 5 6 0 0 0 : 50 ms 0 0 1 : 210 ms 0 1 0 : 500 ms 0 1 1 : 800 ms 1 0 0 : 900 ms 1 0 1 : 1.5 sec. 1 1 0 : 2.0 sec. 1 1 1 : 2.5 sec.
7	No. of 2nd dial tone detection times	0: Once 1: Twice
8	2nd dial tone interrupt detecting time	0: 30 ms 1: 50 ms

NOTE: Selectors 4 through 8 are not applicable in those countries where no dial tone detection is supported, e.g., U.S.A.

- **Selectors 1 through 3: Pause key setting and 2nd dial tone detection**

Selectors			
1	2	3	
0	0	0	No WAIT is inserted even if the Pause key is pressed.
0	0	1	If you press the Pause key during dialing, the facsimile equipment will insert WAIT as defined in the above table.
0	1	0	
0	1	1	
1	0	0	If the Pause key is pressed repeatedly, the equipment inserts the specified WAIT multiplied by the number of depressions. It applies also in hook-up dialing.
1	0	1	<p>When these selectors are set to "1, 0, 1":</p> <p>Each time you press the Pause key in dialing, the equipment will wait for the 2nd dial tone to be sent via the communications line regardless of pulse dialing or tone dialing.</p> <p>When these selectors are set to "1, 1, 0":</p> <p>If you press the Pause key in pulse dialing, the equipment will first wait for the 2nd dial tone to be sent via the communications line. After that, pressing the Pause key will cause the equipment to insert a WAIT of 3.5 seconds. In tone dialing, the equipment will insert a WAIT of 3.5 seconds.</p> <p>When these selectors are set to "1, 1, 1":</p> <p>If you press the Pause key, the equipment will first wait for the 2nd dial tone to be sent via the communications line regardless of pulse dialing or tone dialing. After that, pressing the Pause key will cause the equipment to insert a WAIT of 3.5 seconds.</p> <p>(In those countries where no dial tone detection function is supported, setting these selectors to "1, 0, 1," "1, 1, 0," or "1, 1, 1" inserts a WAIT of 3.5 seconds.)</p>
1	1	0	
1	1	1	

- **Selectors 4 through 6: Detection of international tone**

Upon detection of the 2nd dial tone for the time length specified by these selectors, the equipment starts dialing.

This setting is effective only when the 2nd dial tone detection function is activated by selectors 1 through 3 (Setting 101, 110, or 111).

This function does not apply in those countries where no dial tone detection function is supported.

- **Selector 7: No. of 2nd dial tone detection times**

This selector sets the number of dial tone detection times required for starting dialing.

- **Selector 8: 2nd dial tone interrupt detecting time**

This selector sets the allowable time length of an interrupt which should not be interpreted as an interrupt in the 2nd tone dialing.

WSW07 (Dial tone setting 1)

Selector No.	Function	Setting and Specifications
1 2	Frequency band range	No. 1 2 0 0 : Narrows by 10 Hz 0 1 : Initial value 1 X : Widens by 10 Hz
3	Line current detection	0: No 1: Yes
4 6	2nd dial tone detection level (Z = 600 Ω)	No. 4 5 6 0 0 0 : -21 dBm 0 0 1 : -24 dBm 0 1 0 : -27 dBm 0 1 1 : -30 dBm 1 0 0 : -33 dBm 1 0 1 : -36 dBm 1 1 0 : -39 dBm 1 1 1 : -42 dBm
7	1st dial tone interrupt detecting time	0: 30 ms 1: 50 ms
8	Not used.	

NOTE: Selectors 1, 2, 4 through 7 are not applicable in those countries where no dial tone or line current detection is supported, e.g., U.S.A.

NOTE: Selector 3 is not applicable to those models having no loop current detection function.

- **Selectors 1 and 2: Frequency band range**

These selectors set the frequency band for the 1st dial tone and the busy tone (before dialing) to be detected.

This setting is effective only when selectors 1 through 3 of WSW05 are set to "1,1,1."

- **Selector 3: Line current detection**

This selector determines whether or not the equipment should detect a line current before starting dialing.

- **Selectors 4 through 6: 2nd dial tone detection level**

These selectors set the detection level of the 2nd dial tone.

- **Selector 7: 1st dial tone interrupt detecting time**

This selector sets the allowable time length of an interrupt which should not be interpreted as an interrupt in the 1st dial tone dialing.

WSW08 (Dial tone setting 2)

Selector No.	Function	Setting and Specifications
1 3	1st dial tone detection time length	No. 1 2 3 0 0 0 : 50 ms 0 0 1 : 210 ms 0 1 0 : 500 ms 0 1 1 : 800 ms 1 0 0 : 900 ms 1 0 1 : 1.5 sec. 1 1 0 : 2.0 sec. 1 1 1 : 2.5 sec.
4 5	Time-out length for 1st and 2nd dial tone detection	No. 4 5 0 0 : 10 sec. 0 1 : 20 sec. 1 0 : 15 sec. 1 1 : 30 sec.
6 8	Detection level of 1st dial tone and busy tone before dialing	No. 6 7 8 0 0 0 : -21 dBm 0 0 1 : -24 dBm 0 1 0 : -27 dBm 0 1 1 : -30 dBm 1 0 0 : -33 dBm 1 0 1 : -36 dBm 1 1 0 : -39 dBm 1 1 1 : -42 dBm

NOTE: The WSW08 is not applicable in those countries where no dial tone detection is supported, e.g., U.S.A.

- **Selectors 1 through 3: 1st dial tone detection time length**

Upon detection of the 1st dial tone for the time length set by these selectors, the equipment starts dialing.

This setting is effective only when selectors 1 through 3 of WSW05 are set to "1,1,1."

- **Selectors 4 and 5: Time-out length for 1st and 2nd dial tone detection**

These selectors set the time-out length for the 1st and 2nd dial tone detection so that the equipment waits dial tone input for the specified time length and disconnects itself from the line when no dial tone is inputted.

WSW09 (Protocol definition 1)

Selector No.	Function	Setting and Specifications
1	Frame length selection	0: 256 octets 1: 64 octets
2	Use of non-standard commands	0: Allowed 1: Prohibited
3	No. of retries	No. 3 4 0 0 : 4 times
4		0 1 : 3 times
		1 0 : 2 times
		1 1 : 1 time
5	T5 timer	0: 300 sec. 1: 60 sec.
6	T1 timer	0: 35 sec. 1: 40 sec.
7	Elapsed time for time-out control for no response from the called station in automatic sending mode	No. 7 8 0 0 : $\left\{ \begin{array}{l} 55 \text{ sec. (in U.S.A. and Canadian versions)} \\ 60 \text{ sec. (in other versions)} \end{array} \right.$
8		0 1 : 140 sec.
		1 0 : 90 sec.
		1 1 : 35 sec.

NOTE: Selectors 1 through 5 are not applicable in those models which do not support ECM.

● **Selector 1: Frame length selection**

Usually a single frame consists of 256 octets (1 octet = 8 bits). For communications lines with higher bit error rate, however, set selector 1 to "1" so that the facsimile equipment can divide a message into 64-octet frames.

Remarks: The error correction mode (ECM) is a facsimile transmission manner in which the equipment divides a message into frames for transmission so that if any data error occurs on the transmission line, the equipment retransmits only those frames containing the error data.

● **Selector 2: Use of non-standard commands**

If this selector is set to "0," the equipment may use non-standard commands (the machine's native-mode commands, e.g., NSF, NSC, and NSS) for communications. If it is set to "1," the equipment will use standard commands only.

● **Selectors 3 and 4: No. of retries**

These selectors set the number of retries in each specified modem transmission speed.

● **Selector 5: T5 timer**

This selector sets the time length for the T5 timer.

● **Selector 6: T1 timer**

This selector sets the time length for the T1 timer.

● **Selectors 7 and 8: Elapsed time for time-out control**

If the equipment receives no response (no G3 command) from the called terminal in automatic sending during the time set by these selectors, it disconnects the line.

WSW10 (Protocol definition 2)

Selector No.	Function	Setting and Specifications	
1	Not used.		
2	Time length from transmission of the last dial digit to CML ON	0: 100 ms 1: 50 ms	
3	Time length from CML ON to CNG transmission	0: 2 sec. 1: 4 sec.	
4	Time length from CML ON to CED transmission (except for facsimile-to-telephone switching)	0: 0.5 sec. 1: 2 sec.	
5 6	No. of training retries	No. 5 6 0 0 : 1 time 0 1 : 2 times 1 0 : 3 times 1 1 : 4 times	
7		Encoding system (Compression)	
		MR	0: Allowed 1: Not allowed
8		MMR	0: Allowed 1: Not allowed

- **Selector 2: Time length from transmission of the last dial digit to CML ON**
This selector sets the time length from when the equipment transmits the last dial digit until the CML relay comes on.
- **Selector 3: Time length from CML ON to CNG transmission**
This selector sets the time length until the equipment transmits a CNG after it turns on the CML relay.
- **Selector 4: Time length from CML ON to CED transmission**
This selector sets the time length until the equipment transmits a CED after it turns on the CML relay. This setting does not apply to switching between facsimile and telephone.
- **Selectors 5 and 6: No. of training retries**
These selectors set the number of training retries to be repeated before automatic fallback.
- **Selectors 7 and 8: Encoding system (Compression)**
This selector determines whether or not use of the MR/MMR coding system will be allowed.

WSW11 (Busy tone setting)

Selector No.	Function	Setting and Specifications
1 2	Frequency band range	No. 1 2 0 0 : Narrows by 10 Hz 0 1 : Initial value 1 x : Widens by 10 Hz
3	Not used.	
4	ON/OFF time length ranges (More than one setting allowed)	1: 400-600/400-600 ms
5		1: 175-440/175-440 ms
6		1: 100-1000 ms/17-660 ms
7		1: 110-410/320-550 ms
8		1: 100-660/100-660 ms

NOTE: WSW11 is not applicable in those countries where no busy tone detection is supported.

NOTE: The setting of WSW11 is effective only when selectors 5 and 6 of WSW05 are set to "0, 1" or "1, 1" (Busy tone detection).

- **Selectors 1 and 2: Frequency band range**

These selectors set the frequency band for busy tone to be detected.

- **Selectors 4 through 8: ON/OFF time length ranges**

These selectors set the ON and OFF time length ranges for busy tone to be detected. If more than one selector is set to "1," the ranges become wider. For example, if selectors 4 and 5 are set to "1," the ON and OFF time length ranges are from 175 to 600 ms.

WSW12 (Signal detection condition setting)

Selector No.	Function	Setting and Specifications
1 2	Min. OFF time length of calling signal (Ci)	No. 1 2 0 0 : 1500 ms 0 1 : 500 ms 1 0 : 700 ms 1 1 : 900 ms
3 4	Max. OFF time length of calling signal (Ci)	No. 3 4 0 0 : 6 sec. 0 1 : 7 sec. 1 0 : 9 sec. 1 1 : 11 sec.
5 6	Detecting time setting	No. 5 6 0 0 : 800 ms (1000 ms*) 0 1 : 200 ms 1 0 : 250 ms 1 1 : 150 ms
7 8	Not used.	

*1000 ms in Chinese versions.

- **Selectors 1 through 4: Min. and max. OFF time length of calling signal (Ci)**

If the equipment detects the OFF state of calling signal (Ci) for a time length which is greater than the value set by selectors 1 and 2 and less than the value set by selectors 3 and 4, it interprets the Ci signal as OFF.

- **Selectors 5 and 6: Detecting time setting**

These selectors set the time length required to make the equipment acknowledge itself to be called. That is, if the equipment continuously detects calling signals with the frequency set by selectors 1 through 4 of WSW14 during the time length set by these selectors 5 and 6, it acknowledges the call.

WSW13 (Modem setting)

Selector No.	Function	Setting and Specifications
1 2	Cable equalizer	No. 1 2 0 0 : 0 km 0 1 : 1.8 km 1 0 : 3.6 km 1 1 : 5.6 km
3 4	Reception level	No. 3 4 0 0 : -43 dBm 0 1 : -47 dBm 1 0 : -49 dBm 1 1 : -51 dBm
5 8	Modem attenuator	0: 0 dB 1: 8 dB 0: 0 dB 1: 4 dB 0: 0 dB 1: 2 dB 0: 0 dB 1: 1 dB

The modem should be adjusted according to the user's line conditions.

- **Selectors 1 and 2: Cable equalizer**

These selectors are used to improve the pass-band characteristics of analogue signals on a line. (Attenuation in the high-band frequency is greater than in the low-band frequency.)

Set these selectors according to the distance from the telephone switchboard to the facsimile equipment.

- **Selectors 3 and 4: Reception level**

These selectors set the optimum receive signal level.

- **Selectors 5 through 8: Modem attenuator**

These selectors are used to adjust the transmitting level of the modem when the reception level at the remote station is improper due to line loss. This function applies for G3 protocol signals.

Setting two or more selectors to "1" produces addition of attenuation assigned to each selector.

This setting will be limited if selector 8 of WSW23 is set to "0."

WSW14 (AUTO ANS facility setting)

Selector No.	Function	Setting and Specifications
1 2	Frequency band selection (Lower limit)	No. 1 2 0 0 : 13 Hz 0 1 : 15 Hz 1 0 : 23 Hz 1 1 : 20 Hz
3 4	Frequency band selection (Upper limit)	No. 3 4 0 0 : 30 Hz 0 1 : 55 Hz 1 X : 70 Hz
5 8	No. of rings in AUTO ANS mode	No. 5 6 7 8 0 0 0 0 : Fixed to once 0 0 0 1 : Fixed to 2 times 0 0 1 0 : Fixed to 3 times 0 0 1 1 : Fixed to 4 times 0 1 0 0 : 1 to 2 times 0 1 0 1 : 1 to 3 times 0 1 1 0 : 1 to 4 times 0 1 1 1 : 1 to 5 times 1 0 0 0 : 2 to 3 times 1 0 0 1 : 2 to 4 times 1 0 1 0 : 2 to 5 times 1 0 1 1 : 2 to 6 times 1 1 0 0 : 1 to 10 times 1 1 0 1 : 2 to 10 times 1 1 1 0 : 3 to 5 times 1 1 1 1 : 4 to 10 times

- **Selectors 1 through 4: Frequency band selection**

These selectors are used to select the frequency band of calling signals for activating the AUTO ANS facility.

In the French versions, if the user sets the PBX to OFF from the control panel, the setting made by selectors 1 and 2 will take no effect and the frequency's lower limit will be fixed to 32 Hz. (Even if the setting made by these selectors does not apply, it will be printed on the configuration list.)

- **Selectors 5 through 8: No. of rings in AUTO ANS mode**

These selectors set the number of rings to initiate the AUTO ANS facility.

WSW15 (REDIAL facility setting)

Selector No.	Function	Setting and Specifications
1 2	Selection of redial interval	No. 1 2 0 0 : 5 minutes 0 1 : 1 minute 1 0 : 2 minutes 1 1 : 3 minutes
3 6	No. of redialings	No. 3 4 5 6 0 0 0 0 : 16 times 0 0 0 1 : 1 times 0 0 1 0 : 2 times 0 0 1 1 : 3 times 1 1 1 1 : 15 times
7	Redialing for no response sent from the called terminal	0: Redialing 1: No redialing
8	Not used.	

- **Selectors 1 through 6: Selection of redial interval and No. of redialings**

The equipment redials by the number of times set by selectors 3 through 6 at intervals set by selectors 1 and 2.

- **Selector 7: Redialing for no response sent from the called terminal**

This selector determines whether or not the equipment redials if no G3 command response comes from the called station after dialing within the time length set by selectors 7 and 8 of WSW09.

WSW16 (Function setting 1)

Selector No.	Function	Setting and Specifications
1	Not used.	
2	ITU-T (CCITT) superfine recommendation	0: OFF 1: ON
3 6	Not used.	
7	Max. document length limitation	0: 400 cm 1: 90 cm
8	Stop key pressed during reception	0: Not functional 1: Functional

- **Selector 2: ITU-T (CCITT) superfine recommendation**

If this selector is set to "1," the equipment communicates in ITU-T (CCITT) recommended superfine mode (15.4 lines/mm). If it is set to "0," it communicates in native superfine mode.

- **Selector 7: Max. document length limitation**

This selector is used to select the maximum length of a document to be sent.

- **Selector 8: Stop key pressed during reception**

If this selector is set to "1," pressing the **Stop** key can stop the current receiving operation. The received data will be lost.

WSW17 (Function setting 2)

Selector No.	Function	Setting and Specifications
1 2	Off-hook alarm	No. 1 2 0 0 : No alarm 0 1 : Always valid 1 X : Valid except when 'call reservation' is selected.
3 4	Not used.	
5	Calendar clock type	0: U.S.A. type 1: European type
6	Not used.	
7	Non-ring reception	0: OFF 1: ON
8	Not used.	

NOTE: Selector 4 is not applicable to those models having a 2-row LCD.

- **Selectors 1 and 2: Off-hook alarm**

These selectors activate or deactivate the alarm function which sounds an alarm when the communication is completed with the handset being off the hook.

- **Selector 5: Calendar clock type**

If this selector is set to "0" (USA), the MM/DD/YY hh:mm format applies; if it is set to "1" (Europe), the DD/MM/YY hh:mm format applies: DD is the day, MM is the month, YY is the last two digits of the year, hh is the hour, and mm is the minute.

- **Selector 7: Non-ring reception**

Setting this selector to "1" makes the equipment receive calls without ringer sound if the ring delay is set to 0.

WSW18 (Function setting 3)

Selector No.	Function	Setting and Specifications
1	Not used.	
2 3	Detection enabled time for CNG and no tone	No. 2 3 0 0 : 40 sec. 0 1 : 0 sec. (No detection) 1 0 : 5 sec. 1 1 : 80 sec.
4 5	Not used.	
6	Registration of station ID	0: Permitted 1: Prohibited
7 8	Tone sound monitoring	No. 7 8 0 X : No monitoring 1 0 : Up to phase B at the calling station only 1 1 : All transmission phases both at the calling and called stations

- **Selectors 2 and 3: Detection enabled time for CNG and no tone**

After the line is connected via the external telephone or by picking up the handset of the facsimile equipment, the equipment can detect a CNG signal or no tone for the time length specified by these selectors. The setting specified by these selectors becomes effective only when selector 8 of WSW20 is set to "1."

- **Selector 6: Registration of station ID**

Setting this selector to "0" permits the registration of station ID for Austrian and Czech versions.

- **Selectors 7 and 8: Tone sound monitoring**

These selectors set monitoring specifications of the tone sound inputted from the line.

WSW19 (Transmission speed setting)

Selector No.	Function	Setting and Specifications
1 3	First transmission speed choice for fallback	No. 1 2 3 No. 4 5 6 0 0 0 : 2,400 bps 0 0 1 : 4,800 bps 0 1 0 : 7,200 bps 0 1 1 : 9,600 bps 1 0 0 : 12,000 bps 1 0 1 : } 14,400 bps 1 1 0 : 1 1 1 :
4 6	Last transmission speed choice for fallback	
7	Not used.	
8	V. 17 mode	0: Permitted 1: Prohibited

● **Selectors 1 through 6: First and last choices of transmission speed for fallback**

These selectors are used to set the MODEM speed range. With the first transmission speed choice specified by selectors 1 through 3, the equipment attempts to establish the transmission link via the MODEM. If the establishment fails, the equipment automatically steps down to the next lowest speed and attempts to establish the transmission link again. The equipment repeats this sequence while stepping down the transmission speed to the last choice specified by selectors 4 through 6.

If the MODEM always falls back to a low transmission speed (e.g., 4,800 bps), set the first transmission speed choice to the lower one (e.g., modify it from 12,000 bps to 7,200 bps) in order to deactivate the high-speed MODEM function and reduce the training time for shorter transmission time.

Generally, to save the transmission time, set the last transmission speed choice to a higher one.

WSW20 (Overseas communications mode setting)

Selector No.	Function	Setting and Specifications
1	EP* tone prefix	0: OFF 1: ON
2	Overseas communications mode (Reception)	0: 2100 Hz 1: 1100 Hz
3	Overseas communications mode (Transmission)	0: OFF 1: Ignores DIS once.
4 5	Min. time length from reception of CFR to start of transmission of video signals	No. 4 5
		0 0 : 100 ms
		0 1 : 200 ms
		1 0 : 300 ms
		1 1 : 400 ms
6 7	Not used.	
8	CNG detection on/off	0: OFF 1: ON

* EP: Echo protection

- **Selector 1: EP tone prefix**

Setting this selector to "1" makes the equipment transmit a 1700 Hz echo protection (EP) tone immediately preceding training in V.29 modulation system to prevent omission of training signals.

Prefixing an EP tone is effective when the equipment fails to transmit at the V.29 modem speed and always has to fall back to 4800 bps transmission.

- **Selectors 2 and 3: Overseas communications mode**

These selectors should be used if the facsimile equipment malfunctions in overseas communications. According to the communications error state, select the signal specifications.

Setting selector 2 to "1" allows the equipment to use 1100 Hz CED signal instead of 2100 Hz in receiving operation. This prevents malfunctions resulting from echoes, since the 1100 Hz signal does not disable the echo suppressor (ES) while the 2100 Hz signal does.

Setting selector 3 to "1" allows the equipment to ignore a DIS signal sent from the called station once in sending operation. This operation suppresses echoes since the first DIS signal immediately follows a 2100 Hz CED (which disables the ES) so that it is likely to be affected by echoes in the disabled ES state. However, such a disabled ES state will be removed soon so that the second and the following DIS signals are not susceptible to data distortion due to echoes. Note that some models when called may cause error by receiving a self-outputted DIS.

- **Selectors 8: CNG detection on/off**

If this selector is set to "1," the equipment detects a CNG signal according to the condition preset by selectors 2 and 3 of WSW18 after a line is connected. If it is set to "0," the equipment detects a CNG signal as long as the line is connected.

WSW21 (TAD setting 1)

Selector No.	Function	Setting and Specifications
1 7	Not used.	
8	Erasure of message stored in the memory after the message transfer	0: Yes 1: No

- **Selector 8: Erasure of message stored in the memory after the message transfer**

Setting this selector to "0" will erase the message recorded in the memory after the document retrieval feature transfers the message.

WSW22 (ECM and copy resolution setting)

Selector No.	Function	Setting and Specifications	
1	ECM* in sending	0: ON	1: OFF
2	ECM* in receiving	0: ON	1: OFF
3	Call Waiting Caller ID	0: ON	1: OFF
4	Not used.		
5 8	Acceptable TCF bit error rate (%) (Only at 4800 bps)	0: 0%	1: 8%
		0: 0%	1: 4%
		0: 0%	1: 2%
		0: 0%	1: 1%

* ECM: Error correction mode

NOTE: Selector 3 is applicable to the American versions only.

NOTE: Selectors 5 through 8 are applicable to the Chinese, Taiwanese and Asian versions only.

- **Selector 3: Call Waiting Caller ID**

Setting this selector to "0" allows the user to decide whether or not to interrupt the current call when a new call comes in. If Call Waiting Caller ID service is available in the area and the user subscribes to it, he/she can see information about his/her incoming call on the LCD.

- **Selectors 5 through 8: Acceptable TCF bit error rate (%)**

Setting two or more selectors to "1" produces addition of percent assigned to each selector. If you set selectors 7 and 8 to "1," the acceptable TCF bit error rate will be 3%.

WSW23 (Communications setting)

Selector No.	Function	Setting and Specifications
1	Starting point of training check (TCF)	0: From the head of a series of zeros 1: From any arbitrary point
2 3	Allowable training error rate	No. 2 3 0 0 : 0% 0 1 : 0.5% 1 0 : 1% 1 1 : 2%
4 5		Decoding error rate for transmission of RTN
6 7	Not used.	
8	Limitation of attenuation level	0: Yes 1: No

NOTE: Selector 8 is not applicable to the French versions.

- **Selector 1: Starting point of training check (TCF)**

At the training phase of receiving operation, the called station detects for 1.0 second a training check (TCF) command, a series of zeros which is sent from the calling station for 1.5 seconds to verify training and give the first indication of the acceptability of the line.

This selector sets the starting point from which the called station should start counting those zeros. If this selector is set to "0," the called station starts counting zeros 100 ms after the head of a series of zeros is detected.

If it is set to "1," the called station starts counting zeros upon detection of 10-ms successive zeros 50 ms after the head of a series of zeros is detected. In this case, if the detection of 10-ms successive zeros is too late, the data counting period will become less than 1.0 second, making the called station judge the line condition unacceptable.

- **Selectors 2 and 3: Allowable training error rate**

The called station checks a series of zeros gathered in training (as described in Selector 1) according to the allowable training error rate set by these selectors. If the called station judges the line condition to be accepted, it responds with CFR; if not, it responds with FTT.

- **Selectors 4 and 5: Decoding error rate for transmission of RTN**

The facsimile equipment checks the actual decoding errors and then transmits an RTN according to the decoding error rate (Number of lines containing an error per page ÷ Total number of lines per page) set by these selectors.

- **Selector 8: Limitation of attenuation level**

Setting this selector to "0" limits the transmitting level of the modem to 10 dB.

This setting has priority over the settings selected by WSW02 (selectors 5 through 8) and WSW13 (selectors 5 through 8).

WSW24 (TAD setting 2)

Selector No.	Function	Setting and Specifications
1 2	Not used.	
3 4	Time length from CML ON to start of pseudo ring backtone transmission	No. 3 4 0 0 : 4 sec. 0 1 : 3 sec. 1 0 : 2 sec. 1 1 : 1 sec.
5 8	Not used.	

- **Selectors 3 and 4: Time length from CML ON to start of pseudo ring backtone transmission**

These selectors set the length of time from CML-ON up to the start of pseudo ring backtone transmission.

In those versions which have an OGM facility, the settings made by these selectors also apply to the length of time from CML-ON up to the start of OGM transmission.

WSW25 (TAD setting 3)

Selector No.	Function	Setting and Specifications																																																						
1 4	Not used.																																																							
5 7	Pause between paging number and PIN	<table> <tr> <td>No.</td> <td>5</td> <td>6</td> <td>7</td> <td>:</td> <td></td> </tr> <tr> <td></td> <td>0</td> <td>0</td> <td>0</td> <td>:</td> <td>2 sec.</td> </tr> <tr> <td></td> <td>0</td> <td>0</td> <td>1</td> <td>:</td> <td>4 sec.</td> </tr> <tr> <td></td> <td>0</td> <td>1</td> <td>0</td> <td>:</td> <td>6 sec.</td> </tr> <tr> <td></td> <td>0</td> <td>1</td> <td>1</td> <td>:</td> <td>8 sec.</td> </tr> <tr> <td></td> <td>1</td> <td>0</td> <td>0</td> <td>:</td> <td>10 sec.</td> </tr> <tr> <td></td> <td>1</td> <td>0</td> <td>1</td> <td>:</td> <td>12 sec.</td> </tr> <tr> <td></td> <td>1</td> <td>1</td> <td>0</td> <td>:</td> <td>14 sec.</td> </tr> <tr> <td></td> <td>1</td> <td>1</td> <td>1</td> <td>:</td> <td>16 sec.</td> </tr> </table>	No.	5	6	7	:			0	0	0	:	2 sec.		0	0	1	:	4 sec.		0	1	0	:	6 sec.		0	1	1	:	8 sec.		1	0	0	:	10 sec.		1	0	1	:	12 sec.		1	1	0	:	14 sec.		1	1	1	:	16 sec.
No.	5	6	7	:																																																				
	0	0	0	:	2 sec.																																																			
	0	0	1	:	4 sec.																																																			
	0	1	0	:	6 sec.																																																			
	0	1	1	:	8 sec.																																																			
	1	0	0	:	10 sec.																																																			
	1	0	1	:	12 sec.																																																			
	1	1	0	:	14 sec.																																																			
	1	1	1	:	16 sec.																																																			
8	Not used.																																																							

NOTE: Selectors 5 through 7 are applicable only to the U.S.A. versions.

- **Selectors 5 through 7: Pause between paging number and PIN**

These selectors set the pause time between a telephone number being paged and PIN (private identification number) for the paging feature.

WSW26 (Function setting 4)

Selector No.	Function	Setting and Specifications
1 2	Not used.	
3	Dialing during document reading into the temporary memory in in-memory message transmission	0: Disabled 1: Enabled
4 5	No. of CNG cycles to be detected (when the line is connected via the external telephone except in the external TAD mode or via the built-in telephone)	No. 4 5 0 0 : 0.5 (A) 0 1 : 1 (B) 1 0 : 1.5 (C) 1 1 : 2 (D)
6 8	Not used.	

- **Selector 3: Dialing during document reading into the temporary memory in in-memory message transmission**

If this selector is set to "0," the facsimile equipment waits for document reading into the memory to complete and then starts dialing. This enables the equipment to list the total number of pages in the header of the facsimile message.

- **Selectors 4 and 5: No. of CNG cycles to be detected**

The equipment interprets a CNG as an effective signal if it detects a CNG signal by the number of cycles specified by these selectors when the line is connected via the external telephone except in the external TAD mode or via the built-in telephone.

WSW27 (Function setting 5)

Selector No.	Function	Setting and Specifications
1	Not used.	
2	Ringer OFF setting	0: Yes 1: No
3	Not used.	
4	Detection of distinctive ringing pattern	0: Yes 1: No
5 8	Not used.	

NOTE: Selector 4 is applicable only to the U.S.A. versions.

- **Selector 2: Ringer OFF setting**

This selector determines whether or not the ringer can be set to OFF.

- **Selector 4: Detection of distinctive ringing pattern**

If this selector is set to "1," the equipment detects only the number of rings; if it is set to "0," the equipment detects the number of rings and the ringing time length to compare the detected ringing pattern with the registered distinctive one.

WSW28 (Function setting 6)

Selector No.	Function	Setting and Specifications
1 3	Transmission level of DTMF high-band frequency signal	No. 1 2 3 0 0 0 : 0 dB 0 0 1 : +1 dB 0 1 0 : +2 dB 0 1 1 : +3 dB 1 0 0 : 0 dB 1 0 1 : -1 dB 1 1 0 : -2 dB 1 1 1 : -3 dB
4 6	Transmission level of DTMF low-band frequency signal	No. 4 5 6 0 0 0 : 0 dB 0 0 1 : +1 dB 0 1 0 : +2 dB 0 1 1 : +3 dB 1 0 0 : 0 dB 1 0 1 : -1 dB 1 1 0 : -2 dB 1 1 1 : -3 dB
7 8	Not used.	

- **Selectors 1 through 6: Transmission level of DTMF high-/low-band frequency signal**

These selectors are intended for the manufacturer who tests the equipment for the Standard. Never access them.

WSW29 (Function setting 7)

Selector No.	Function	Setting and Specifications
1 6	Not used.	
7	Impedance switching control in pulse dialing	0: OFF 1: ON
8	Prompt beep when the memory area for the activity report becomes full	0: No 1: Yes

NOTE: Selectors 7 and 8 are applicable only to the European versions.

- **Selector 8: Prompt beep for activity report**

This selector determines whether or not the equipment will beep if the memory area for the activity report becomes full, for prompting you to print out the report. (Printing it out will clear the memory area.)

WSW30

Selector No.	Function	Setting and Specifications
1 8	Not used.	

WSW31 (Function setting 9)

Selector No.	Function	Setting and Specifications
1	Not used.	
2	Default reduction rate for failure of automatic reduction during recording	0: 100% 1: 70%
3	Not used.	
4	Black ink empty sensor	0: Yes 1: No
5	Minimum short-OFF duration in distinctive ringing	0: 130 ms 1: 90 ms
6 8	Not used.	

NOTE: Selector 5 is applicable only to the U.S.A. versions.

- **Selector 2: Default reduction rate for failure of automatic reduction during recording**

This selector sets the default reduction rate to be applied if the automatic reduction function fails to record one-page data sent from the calling station in a single page of the current recording paper.

If it is set to "0," the equipment records one-page data at full size (100%) without reduction; if it is set to "1," the equipment records it at 70% size.

- **Selector 5 Minimum short-OFF duration in distinctive ringing**

The ringer pattern consists of short and long rings, e.g., short-short-long rings. This selector sets the minimum OFF duration following a short ring in order to avoid missing ringer tones in distinctive ringing.

If this selector is set to "1," when the short-OFF duration is a minimum of 90 ms long, then the equipment will interpret the short-OFF as OFF.

WSW32 (Function setting 10)

Selector No.	Function	Setting and Specifications
1 4	Not used.	
5 6	Default resolution	No. 5 6 0 0 : Standard 0 1 : Fine 1 0 : Super fine 1 1 : Photo
7 8	Default contrast	No. 7 8 0 X : Automatic 1 0 : Super light 1 1 : Super dark

- **Selectors 5 and 6: Default resolution**

These selectors set the default resolution which applies when the equipment is turned on or completes a transaction.

- **Selectors 7 and 8: Default contrast**

These selectors set the default contrast which applies when the equipment is turned on or completes a transaction.

WSW33 (Function setting 11)

Selector No.	Function	Setting and Specifications
1 3	Not used.	
4 5	FAX receiving speed to be kept within the transmission speed limit to the PC	No. 4 5 0 0 : 14,400 bps 0 1 : 12,000 bps 1 0 : 9,600 bps 1 1 : 7,200 bps
6	Report output of polled transmission requests	0: Yes 1: No
7 8	Not used.	

- **Selectors 4 and 5: FAX receiving speed to be kept within the transmission speed limit to the PC**

To transmit FAX data being received from other facsimile equipment to the connected PC, you may need to keep the FAX receiving speed within the transmission speed limit to the PC. In an initial negotiation sequence for transmission, the equipment responds to the calling station with the allowable FAX receiving speed specified by these selectors.

WSW34 (Function setting 12)

Selector No.	Function	Setting and Specifications
1 3	Not used.	
4 5	No. of CNG cycles to be detected (when the line is connected via the external telephone in the external TAD mode or via the facsimile equipment in F/T mode)	No. 4 5 0 0 : 0.5 (A) 0 1 : 1 (B) 1 0 : 1.5 (C) 1 1 : 2 (D)
6 7	Number of DTMF tone signals for inhibiting the detection of CNG during external TAD operation	No. 6 7 0 0 : 3 0 1 : 2 1 0 : 1 1 1 : OFF
8	Not used.	

● **Selectors 4 and 5: No. of CNG cycles to be detected**

The equipment interprets a CNG as an effective signal if it detects a CNG signal by the number of cycles specified by these selectors when the line is connected via the external telephone in the external TAD mode or via the facsimile equipment in F/T mode.

● **Selectors 6 and 7: Number of DTMF tone signals for inhibiting the detection of CNG during external TAD operation**

If the equipment receives this specified number of DTMF tone signals during external TAD operation, it will not detect CNG afterwards.

If these selectors are set to "1, 1," the CNG detection will not be inhibited.

WSW35

Selector No.	Function	Setting and Specifications
1 8	Not used.	

WSW36 (Function setting 14)

Selector No.	Function	Setting and Specifications
1	ECP mode*	0: ON 1: OFF
2	Recovery from Inactive PC Interface	0: Disabled 1: Enabled
3	PC Power-off Recognition Time	0: Normal 1: Long
4	Not used.	
5	Escape from phase C	0: Yes 1: No
6 8	Lower limit of frequency to be ignored after detection of calling signals (Ci)	No. 6 7 8 0 0 0 : 0 (Not ignored) 0 0 1 : 4 (448 Hz) 0 1 0 : 8 (244 Hz) 0 1 1 : 12 (162 Hz) 1 0 0 : 16 (122 Hz) 1 0 1 : 20 (97 Hz) 1 1 0 : 24 (81 Hz) 1 1 1 : 28 (69 Hz)

*ECP (Enhanced Capabilities Port)

● **Selector 1: ECP mode**

The ECP mode enhances the normal bidirectional communications between the facsimile equipment and the connected PC for higher transmission speed.

● **Selector 2: Recovery from Inactive PC Interface**

If the facsimile equipment recognizes via the STB signal line that the connected PC is powered off, it will turn the PC interface outputs Low to protect the PC from hazards that could be caused by weak electric current accidentally flown from the equipment.

This selector determines whether the equipment should recover from the inactive PC interface to normal interfacing state upon receipt of data from the PC.

● **Selector 3: PC Power-off Recognition Time**

This selector sets the time length from when the equipment detects the PC powered off until it recognizes the detected state as power-off.

If selector 2 is set to "0," it is recommended that selector 3 be set to "1"; otherwise, the equipment may mistakenly detect PC powered off.

● **Selector 5: Escape from phase C**

This selector determines whether or not the equipment will escape from phase C when it detects an RTC (Return to Control) in non-ECM mode or an RCP (Return to Control Partial page) in ECM mode.

● **Selectors 6 through 8: Lower limit of frequency to be ignored after detection of calling signals (Ci)**

At the start of reception, if the equipment detects the frequency of calling signals (Ci) specified by selectors 1 through 4 of WSW14, it will start the ringer sounding. When doing so, the equipment may fail to detect the calling signals normally due to noises superimposed at the time of reception. To prevent it, use selectors 6 through 8 of WSW36.

If the equipment detects higher frequencies than the lower limit specified by these selectors, it will regard them as noise and interpret that detecting state as being normal, allowing the ringer to keep sounding (until the equipment starts automatic reception of FAX data if in the FAX mode or enters the TAD mode if set in the TEL mode, according to the preset number of ringers).

WSW37 (Function setting 15)

Selector No.	Function	Setting and Specifications
1	Printout of the stored image data of an unsend document onto an error report	0: No 1: Yes
2	Erasure of the stored image data of an unsend document at the time of the subsequent in-memory message transmission	0: No 1: Yes
3 8	Not used.	

- **Selector 1: Printout of the stored image data of an unsend document onto an error report**

This selector determines whether or not the 1st-page image data of a document will be printed out onto the error report if the document image data stored in the temporary memory cannot be transmitted normally.

- **Selector 2: Erasure of the stored image data of an unsend document at the time of the subsequent in-memory message transmission**

If in-memory message transmission fails repeatedly when selector 1 is set to "1," the temporary memory will be occupied with image data. Setting selector 2 to "1" will automatically erase the stored 1st-page image data of an unsend document at the time of the subsequent in-memory message transmission only when recording paper or toner runs out.

WSW38 to WSW41

Selector No.	Function	Setting and Specifications
1 8	Not used.	

WSW42 (Function setting 20)

Selector No.	Function	Setting and Specifications
1 3	Not used.	
4	JBIG coding	0: Disabled 1: Enabled
5 8	Not used.	

WSW43 (Function setting 21)

Selector No.	Function	Setting and Specifications
1	Not used.	
2 3	Wait time for PC-Fax reception (Class 2) and FPTS command transmission	No. 2 3 0 0 : 50 ms 0 1 : 100 ms 1 0 : 150 ms 1 1 : 0 ms
4 6	Not used.	
7	Automatic start of remote maintenance	0: No 1: Yes
8	JPEG coding	0: Disabled 1: Enabled

● **Selector 8: JPEG coding**

Setting this selector to "0" disables the equipment from sending/receiving JPEG color images and from receiving JPEG monochrome images.

WSW44

Selector No.	Function	Setting and Specifications
1 8	Not used.	

WSW45

Selector No.	Function	Setting and Specifications
1 8	Not used.	

[B] Printout of firmware switch data

■ Function

The equipment prints out the setting items and contents specified by the firmware switches.

■ Operating Procedure

- (1) Press the **1** key twice in the initial stage of the maintenance mode.
The "PRINTING" will appear on the LCD.
- (2) The equipment prints out the configuration list as shown in the figure below.
- (3) Upon completion of printing, the equipment returns to the initial stage of the maintenance mode.

CONFIGURATION LIST

MODEL: 8XA-303
 TIME : 07/09/2000 07:43
 REV. : U0007091845VER.B
 PCT : 5.00
 SUM : A4BB
 SER. #: BR0D09000109

WSW01 = 00000010			
1-2. DIAL FORMAT	: NORMAL		
3-4. BREAK TIME	: 60 MS		
5-6. INTERDIGIT PAUSE	: 600 MS		
7. DP/PB CHANGE IN USER SW	: NO		
8. DP/PB FIXING SELECTION	: PB		
WSW02 = 1111010			
1-2. ON TIME	: 100 MS		
3-4. OFF TIME	: 140 MS		
5-8. LINE BEEP ATTENUATOR	: 10 DB		
WSW03 = 10000000			
1. PARA. CNG DETECTION2	: B		
2-4. NOT USED			
5. PARA. CNG DETECTION1	: A		
6-8. NOT USED			
WSW04 = 00010111			
1-6. NOT USED			
7-8. FLASHING TIME	: 500 MS		
WSW05 = 00000110			
1-3. DIAL TONE DETECTION	: 3.5 SEC WAITING		
4. REMOTE ID DETECTION TIMEOUT	: 2 SEC		
5-6. BUSY TONE DETECTION (CALLING)	: AFTER DIALING		
7. BUSY TONE DETECTION (CALLED)	: OFF		
8. NOT USED			
WSW06 = 00101100			
1-3. PAUSE KEY	: 3.5 SEC WAITING		
4-6. 2ND DT DETECTION TIME	: 800 MS		
7. 2ND DT DETECTION CYCLE	: 1 CYCLE		
8. 2ND DT INTERRUPT DETECTION TIME	: 30 MS		
WSW07 = 01001100			
1-2. FREQUENCY RANGE	: INITIAL DATA		
3. NOT USED			
4-6. 2ND DT DETECTION LEVEL	: -30 DBM		
7. 1ST DT INTERRUPT DETECTION TIME	: 30 MS		
8. NOT USED			
WSW08 = 01100100			
1-3. 1ST DT DETECTION TIME	: 800 MS		
4-5. 1ST/2ND DT TIME OUT	: 10 SEC		
6-8. 1ST DT DETECTION LEVEL	: -33 DBM		
WSW09 = 00000000			
1. ECH FRAME	: 256 OCTET		
2. NON STANDARD FACILITIES	: ON		
3-4. TIMES OF FALL BACK	: 4		
5. T5 TIMER	: 300 SEC		
6. T1 TIMER	: 35 SEC		
7-8. CALLING TIMEOUT	: 55 SEC		
WSW10 = 00010100			
1. NOT USED			
2. TIMING OF LAST DIGIT-MODEM CHANGE	: 100 MS		
3. TIMING OF CML ON CNG TRANSMISSION	: 2 SEC		
4. TIMING OF CML ON CED TRANSMISSION	: 2 SEC		
5-6. TRAINING RETRIES	: 2		
7. CODING METHOD MR	: ON		
8. CODING METHOD MMR	: ON		
WSW11 = 01011000			
1-2. FREQUENCY RANGE	: INITIAL DATA		
3. NOT USED			
4-8. ON/OFF TIME	: 175 - 600 / 175 - 600 MS		
WSW12 = 10011011			
1-2. OFF DETECTION TIME	: 700 MS		
3-4. AUTO ANS OFF DETECTION TIME	: 7 SEC		
5-6. ON DETECTION TIME	: 250 MS		
7-8. NOT USED			
6-7. NOT USED			
8. ATTENUATOR LIMIT	: YES		
WSW24 = 01000010			
1-2. NOT USED			
3-4. DELAY OF CML ON-OGM	: 4 SEC		
5-8. NOT USED			
2. DELETE AN IMAGE ON XMIT REPORT AT NEXT TX	: OFF		
3-8. NOT USED			
WSW38 = 00010100			
1-8. NOT USED			
WSW39 = 11110000			
1-8. NOT USED			

Configuration List

3.6 Operational Check of LCD

■ Function

This function allows you to check whether the LCD on the control panel works normally.

■ Operating Procedure

- (1) Press the **1** and **2** keys in this order in the initial stage of the maintenance mode.

The LCD shows

- (2) Press the **Start** key. Each time you press the **Start** key, the LCD cycles through the displays shown at right.

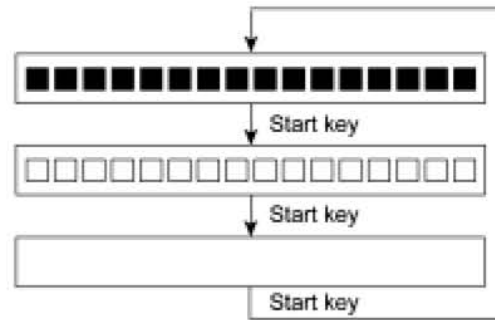

- (3) Press the **Stop** key in any process of the above display cycle. The equipment beeps for one second and returns to the initial stage of the maintenance mode.

3.7 Operational Check of Control Panel PCB

■ Function

This function allows you to check the control panel PCB for normal operation.

■ Operating Procedure

- (1) Press the **1** and **3** keys in this order in the initial stage of the maintenance mode.

The "00 " will appear on the LCD.

- (2) Press the keys and buttons in the order designated in the illustration shown below.

The LCD shows the corresponding number in decimal notation each time a key or button is pressed. Check that the displayed number is correct by referring to the illustration below.

If a key or button is pressed out of order, the equipment beeps and displays the "INVALID OPERATE" on the LCD. To return to the status ready to accept key & button entry for operational check, press the **Stop** key.

- (3) After the last number key or button is pressed, the equipment beeps and returns to the initial stage of the maintenance mode.

To terminate this operation, press the **Stop** key. The equipment returns to the initial stage of the maintenance mode.

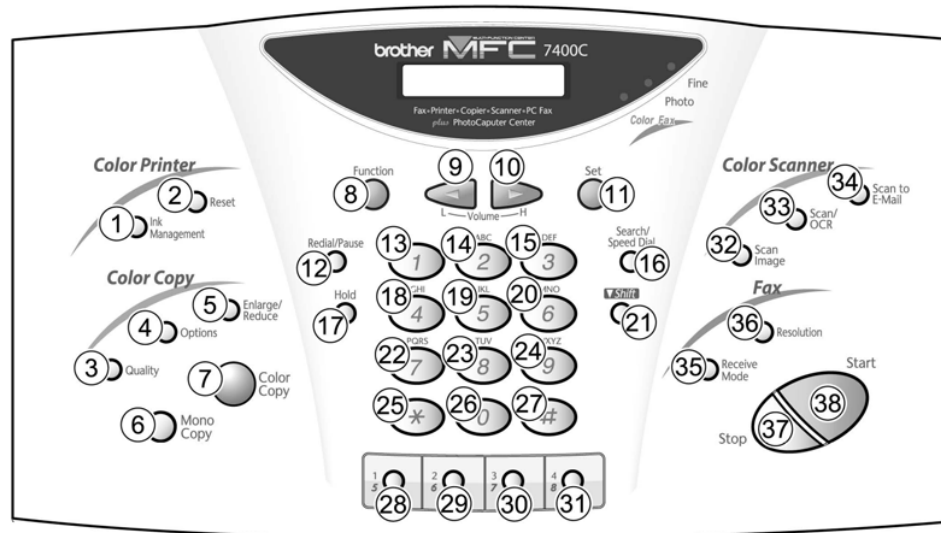

Key & Button Entry Order

3.8 Receiver Volume Adjustment

■ Function

The HIGH level of the handset receiver's volume will be influenced by the characteristics of the FET on the main PCB, so it requires fine adjustment according to the procedure given below.

■ Operating Procedure

- (1) Connect the telephone line cord to the modular jack of the facsimile equipment and the telephone wall socket.
- (2) Pick up the handset and listen to the dial tone. If the receiver volume is not appropriate, proceed to the following steps:
- (3) Press the **1** and **6** keys in this order in the initial stage of the maintenance mode.
The LCD shows the current receiver volume (default: HIGH).
- (4) If the current receiver volume is not HIGH, use the right or left arrow key to choose HIGH.
- (5) Press the **Start** key.
The equipment enters the receiver volume adjustment mode and shows the PWM duty ratio at the right end of the LCD.
- (6) Adjust the receiver volume by using the **1**, **3**, **4**, or **6** key.
1 key: Decrease 10H
3 key: Increase 10 H
4 key: Decrease 1H
6 key: Increase 1H
- (7) To escape from the receiver volume adjustment mode, press the **Set** key.
The LCD shows the "PWM SETTING." One second later, the LCD returns to the screen shown in step (3).
- (8) To return the equipment to the initial stage of the maintenance mode, press the **Stop** key.

3.9 Sensor Operational Check

■ Function

This function allows you to check that the following sensors operate correctly.

- Document front sensor
- Document rear sensor
- Cover/panel open sensor
- Registration sensor
- Hook switch*
- Paper ejection sensor
- Purge cam HP switch
- Pump switching cam HP switch
- Head property EEPROMs
- Black ink cartridge sensor
- Yellow ink cartridge sensor
- Cyan ink cartridge sensor
- Magenta ink cartridge sensor

*For models w/ handset

■ Operating Procedure

- (1) Press the **3** and **2** keys in this order in the initial stage of the maintenance mode. The equipment sounds 1100 Hz and 400 Hz tones cyclically through the following volumes for testing the speaker:

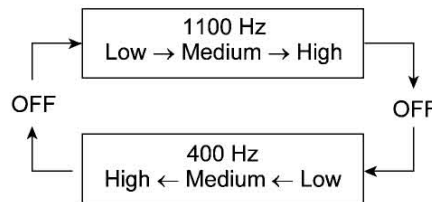

NOTE: To stop beeping, press the **Function** key (American models) or **Menu** key (European models).

If the sensing status are as listed below, the LCD will show "DFDRCVRSHKPOP1P2" and "HDIKIYICIM," which can be switched by pressing the **Start** key.

Given below is the relationship between the LCD indication, sensor name and sensor status.

LCD	Sensors	Sensor signal ON
DF	Document front sensor	No document detected.
DR	Document rear sensor	No document detected.
CV	Cover/panel open sensor	Top cover and control panel ASSY closed.
RS	Registration sensor	No recording paper detected.
HK	Hook switch	On-hook state.
PO	Paper ejection sensor	No recording paper detected.
P1	Purge cam HP switch	Purge cam placed in the home position.
P2	Pump switching cam HP switch	Pump switching cam placed in the home position.
HD	Head property EEPROMs	Head (rank) detected.
IK	Black ink cartridge sensor	Black ink cartridge loaded.
IY	Yellow ink cartridge sensor	Yellow ink cartridge loaded.
IC	Cyan ink cartridge sensor	Cyan ink cartridge loaded.
IM	Magenta ink cartridge sensor	Magenta ink cartridge loaded.

- (2) Change the detecting conditions and check that the displayed letters disappear. For example, insert a document through the document front sensor and check that the "DF" disappears.
- (3) To stop this operation and return the equipment to the initial stage of the maintenance mode, press the **Stop** key.

3.10 Fine Adjustment of Scanning Start/End Position

■ Function

This function allows you to adjust the scanning start/end position.

■ Operating Procedure

- (1) Press the **5** and **4** keys in this order in the initial stage of the maintenance mode.

The LCD shows the current scanning position correction value as shown at right.

- (2) Press the **Start** key. Each time you press the **Start** key, the LCD cycles through the displays shown at right.

That is, pressing this key cycles through the correction values (mm) as shown below.

0 → -1 → -2 → +1

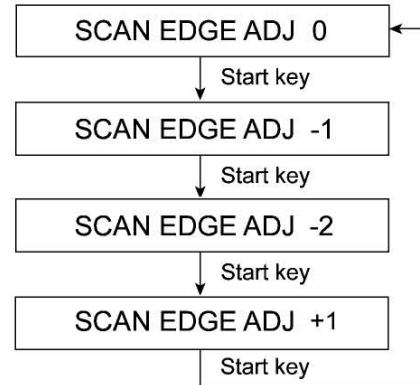

- (3) To stop this operation, press the **Stop** key. The equipment beeps for one second and returns to the initial stage of the maintenance mode.

NOTE: The relationship between the scanning start/end positions and their correction values is shown below.

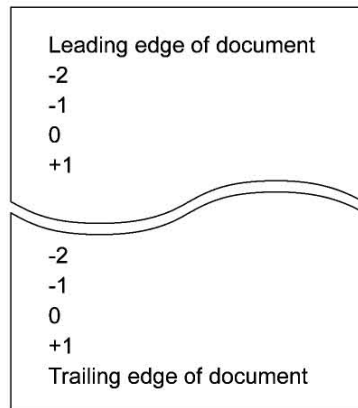

3.11 CIS Scanner Area Setting

■ Function

The equipment sets the CIS scanner area and stores it into the EEPROM.

■ Operating Procedure

- (1) Press the **5** key twice in the initial stage of the maintenance mode.

The "SCANNER AREA SET," "BLACK LEVEL INIT," and "WHITE LEVEL INIT" will appear on the LCD in this order.

The equipment checks and sets the area to be scanned.

If no error is noted, the equipment returns to the initial stage of the maintenance mode.

If any error is noted, the "SCANNER ERROR" will appear on the LCD. To return the equipment to the initial stage of the maintenance mode, press the **Stop** key.

3.12 Setting the Sensing Reference Level of Black Ink Empty Sensor

■ Function

This function allows you to set the sensing reference level of the black ink empty sensor which apply when the controller judges whether there is ink in the black ink cartridge. The setting procedure requires a foam-empty cartridge as a reference cartridge.

NOTE: If you replace the carriage PCB or both the main PCB and the print head unit at the same time, carry out this procedure.

■ Operating Procedure

Handling notes for the reference cartridge: Shown below is a foam-empty cartridge to be used for setting the sensing reference level of the black ink empty sensor. Do not touch section "x" or "y."

If any dust or dirt is found on "x" or "y," wipe it off with a soft cloth. If "x" is scratched, replace the cartridge with a new one. Using such a scratched cartridge will fail to set correct reference level. After completion of the setting procedure, store the cartridge in the container.

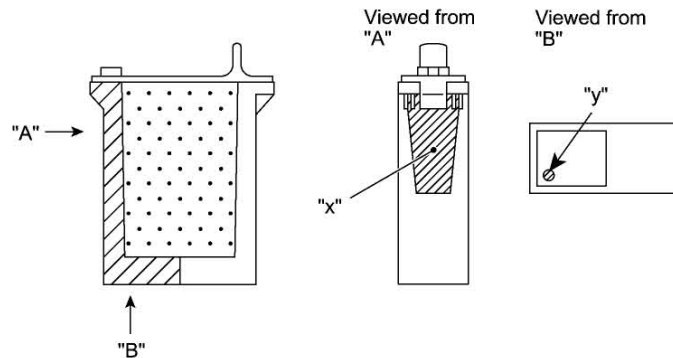

Foam-empty cartridge

- (1) Press the **5** and **7** keys in this order in the initial stage of the maintenance mode.
The LCD shows the "BKEMP TEST START" and "REMOVE ALL CART!" alternately.
- (2) Open the control panel and top cover.
The carriage automatically moves left to the ink replacement position.
- (3) Remove all ink cartridges, one at a time.
- (4) Close the top cover and control panel.
- (5) Press the **Stop** key to return to the initial stage of the maintenance mode.
- (6) Press the **5** and **7** keys in this order again.
The LCD shows the "BKEMP TEST START" and "SET F.EMP CART!" alternately.
- (7) Open the control panel and top cover.
The carriage automatically moves left to the ink replacement position.

(8) Set the foam-empty cartridge into the black ink cartridge position.

(9) Close the top cover and control panel.

The equipment shows the "-BKEMP CHECK-" and starts setting the sensing level for the foam-empty cartridge.

If the equipment completes setting normally, it beeps and displays the "BKEMP TEST OK!" Two seconds later, the "SET ALL NEW CART" appears. If it fails, the "BKEMP F.EMP:NG!" appears, so press the **Stop** key and go back to step (1).

(10) Open the control panel and top cover, and remove the foam-empty cartridge.

(11) Load all ink cartridges removed in step (3) back into place.

(12) Close the top cover and control panel.

The equipment shows the "PURGE TYPE 12345?" on the LCD.

- 1: Ordinary purging
- 2: Double purging
- 3: Triple purging
- 4: Quadruple purging
- 5: Ink priming

(13) Choose the desired type of purging operation by using any of the **1** through **5** keys. (Usually choose "5: Ink priming.")

The equipment automatically carries out purging for all colors of ink and then aging of the carriage (to obtain the initial value of the PWM). This will take approx. 7 minutes if you choose "5: Ink priming."

(14) Press the **Stop** key to return to the initial stage of the maintenance mode.

3.13 Setting ID Codes to Facsimile Machines Connected to a PC via USB

■ Function

If more than one facsimile machine of the same model is connected to a PC via USB, you may assign ID codes (character strings) to those machines according to the procedure given here so that the PC can correctly identify them. For models covered by this manual, set serial numbers given to individual machines as ID codes.

■ Connecting each of facsimile machines to your PC

- (1) Make sure that your PC is turned off.
- (2) Make sure that the machine's power cord is unplugged from a wall socket.
- (3) Connect the interface cable to the parallel interface port on the back of the facsimile machine and secure it with the lock wires.
- (4) Connect the other end of the interface cable to the printer port of your PC and secure it with the two screws.
- (5) Plug the machine's power cord into a wall socket.
- (6) Turn on your PC.

■ Operating Procedure

- (1) Press the **6** and **2** keys in this order in the initial stage of the maintenance mode.
The machine stands by to accept an ID code.
- (2) On your PC, run the ID setting utility. Follow the instructions shown on the PC's screen to enter the 9-digit serial number (e.g., G01012345) printed on the nameplate attached to the back of the facsimile machine as an ID code. Then press the Enter key.
The ID setting utility will transmit the ID code data from your PC to the facsimile machine and then it will terminate.
The facsimile machine will automatically return to the initial stage of the maintenance mode.
- (3) To check that the entered character string (ID code) is correct, press the **1** key twice.
The facsimile machine will print out a Configuration List. At the right top of the list, "SER.#: BROXXXXXXXX" is printed.
- (4) Check that the character string entered in step (2) is printed in "XXXXXXXXX."
If it is OK, press the **9** key twice to exit from the maintenance mode.
If something other than that is printed in XXXXXXXXXXX, check the connection between the PC and facsimile machine and go back to step (1).

3.14 Alignment of Vertical Print Lines

■ Function

This function allows you to align not only vertical lines printed in the forward and backward direction of the carriage but also vertical/horizontal lines printed by the right and left print heads.

■ Operating Procedure

- (1) Set the nozzle adjuster lever to the center position.

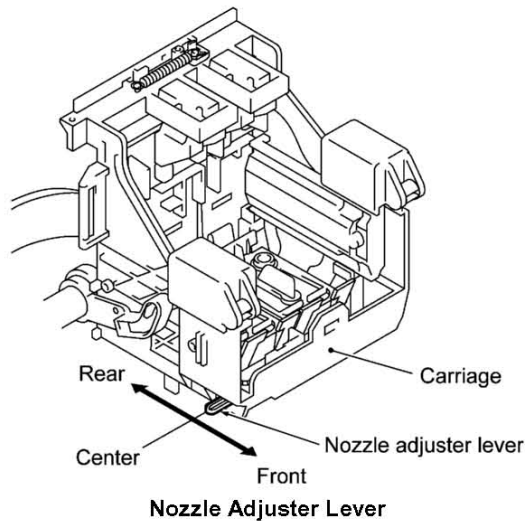

- (2) Press the **6** and **5** keys in this order in the initial stage of the maintenance mode.
The equipment prints out a set of vertical alignment check patterns which consist of No. 1 to No. 9 lines for each of the 300 dpi (fast), 300 dpi, 600 dpi, and 1200 dpi.
If the vertical alignment is ON, No. 5 line (each in the 300 dpi (fast), 300 dpi, 600 dpi, and 1200 dpi printouts) shows vertically aligned lines as shown on pages V-63 and V-64.
The LCD shows the "300 FAST NO.(1-9)."
 - (3) Check the printed vertical alignment check patterns for the 300 dpi (fast) and find which number line shows full alignment. If the line is other than No. 5, enter that line number by using the numerical keys. In the example given on the next page, No. 5 line is not aligned and No. 9 line is fully aligned, so press the **9** key.
The LCD shows the "300 DPI NO.(1-9)."
 - (4) For the 300 dpi, perform the same operation as in step (3).
The LCD shows the "600 DPI NO.(1-9)."
 - (5) For the 600 dpi, perform the same operation as in step (3).
The LCD shows the "1200DPI NO.(1-9)."
 - (6) For the 1200 dpi, perform the same operation as in step (3).
The LCD shows the "NOZZLE NO.(1-3)."
 - (7) Check the nozzle test pattern and find which number block (from 1 through 3) shows the aligned height between the black block and magenta block. This is to correct a positioning error between the right and left print heads.
In the example given on page V-65, No. 3 block of the FRONT row shows the aligned height, so set the nozzle adjuster lever to the front position and press the **3** key.
The LCD shows the "COLOR NO.(1-9)."

- (8) Check the color position test pattern and find which number line (from 1 through 9) shows the vertical alignment of black vertical line with magenta one. This is to correct an ink jet speed error between the right and left print heads.

In the example given on page V-65, No 5 line shows the vertical alignment, so press the **5** key.

The equipment automatically returns to the initial stage of the maintenance mode.

NOTE: If No. 1 line or No. 9 line is fully aligned so that you press the **1** or **9** key in the above procedure, go back to step (1) to confirm that No. 5 line becomes aligned.

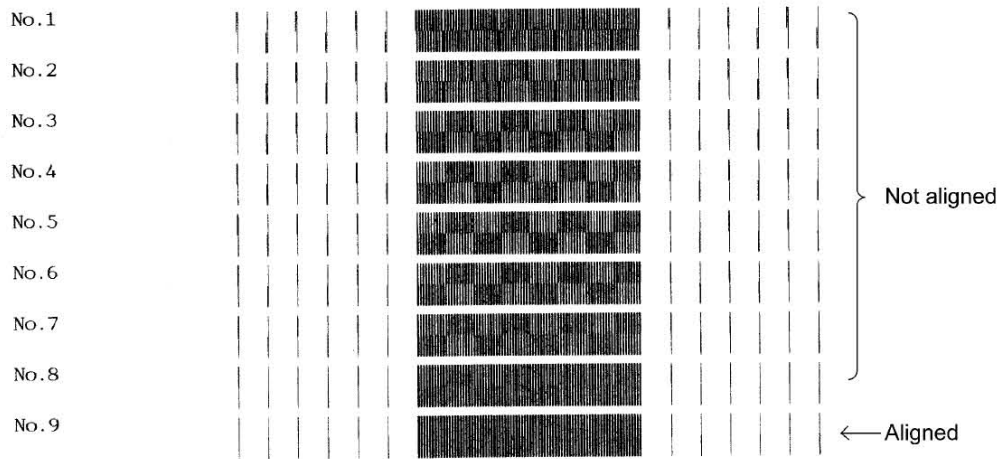

Vertical Alignment Check Pattern—Alignment OFF

300 dpi(Fast) test

No.1

No.2

No.3

No.4

No.5

No.6

No.7

No.8

No.9

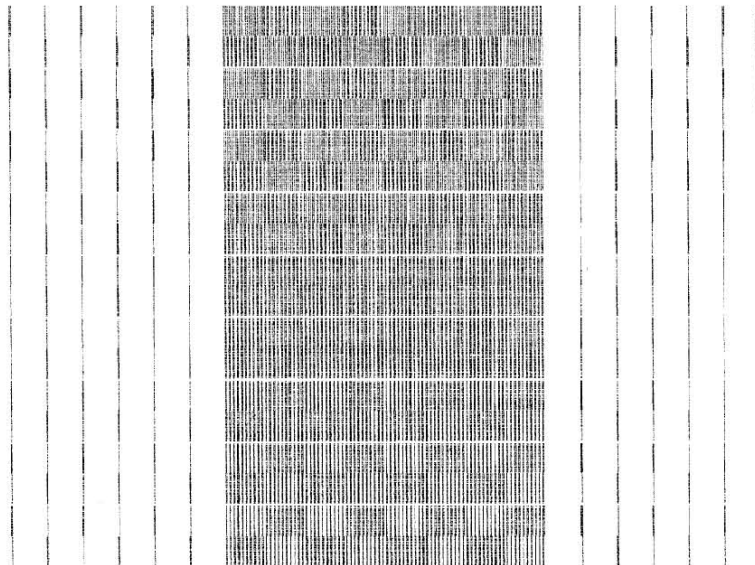

← Aligned

300 dpi test

No.1

No.2

No.3

No.4

No.5

No.6

No.7

No.8

No.9

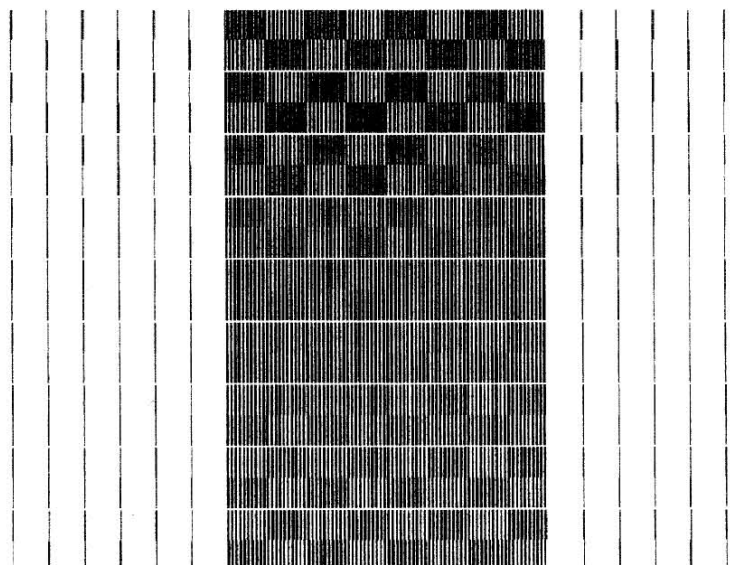

← Aligned

Vertical Alignment Check Pattern—Alignment ON

600 dpi test

No.1

No.2

No.3

No.4

No.5

No.6

No.7

No.8

No.9

1200 dpi test

No.1

No.2

No.3

No.4

No.5

No.6

No.7

No.8

No.9

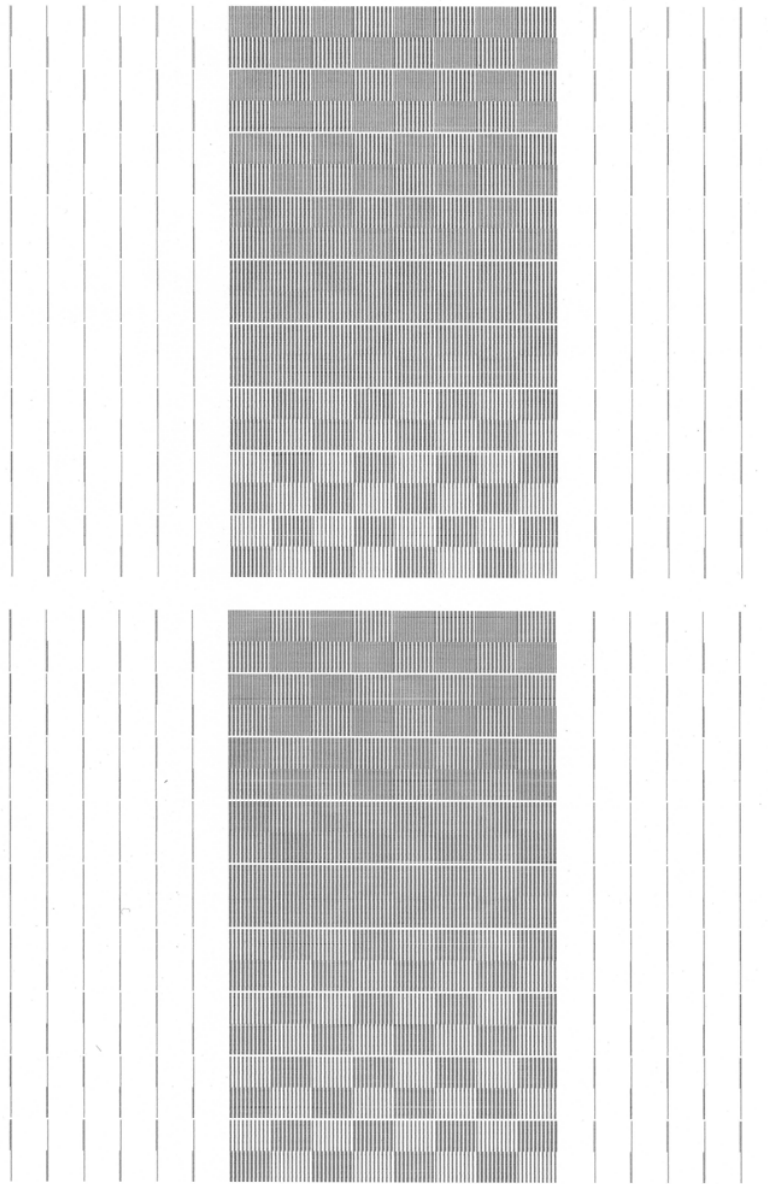

← Aligned

← Aligned

Vertical Alignment Check Pattern—Alignment ON

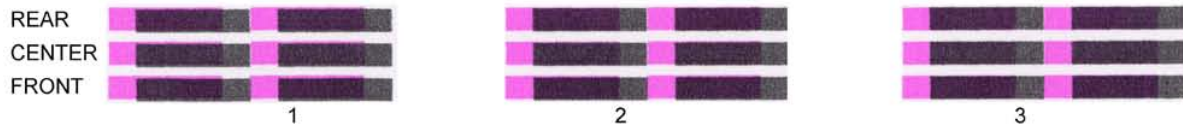

Nozzle Test Pattern



Color Position Test Pattern

3.15 Initial Adjustment of PWM Value (Aging of the Carriage)

■ Function

This function obtains the initial value of the PWM by aging the carriage and writes it onto the EEPROM, as well as checking the head drive voltage level.

This aging procedure should be performed if you replace the print head, carriage ASSY, carriage motor, or encoder strip or if you loosen the timing belt.

NOTE: Opening the top cover or the control panel ASSY during the aging procedure will result in an error. If you perform this aging procedure with either of them opened, the equipment will slowly age the carriage resulting in an error after completion of the aging.

■ Operating Procedure

- (1) Press the **6** and **9** keys in this order in the initial stage of the maintenance mode.

The equipment starts aging the carriage, showing the "CR AGING" on the LCD.

After writing the initial value of the PWM onto the EEPROM and checking the head drive voltage level, the equipment automatically returns to the initial stage of the maintenance mode.

If any error occurs, the equipment beeps and shows "CR AGING :ERROR" on the LCD. To return to the initial stage of the maintenance mode, press the **Stop** key.

3.16 EEPROM Customizing

■ Function

This function allows you to customize the EEPROM according to language, function settings, and firmware switch settings. The customizing codes list is given in Appendix 1.

NOTE: If you replace the main PCB, be sure to carry out this procedure.

■ Operating Procedure

- (1) Press the **7** and **4** keys in this order in the initial stage of the maintenance mode.

The current customizing code (e.g., 9101 in the case of MFC7400C U.S.A. versions) appears.

- (2) Enter the desired customizing code (e.g., 0102 in the case of MFC7400C Canadian versions).

The newly entered code appears.

NOTE: If a wrong 4-digit code is entered, the equipment will malfunction.

- (3) Press the **Start** key.

The equipment saves the setting and returns to the initial stage of the maintenance mode.

If you press the **Stop** key or no keys are pressed for one minute in the above procedure, the equipment stops the procedure and returns to the initial stage of the maintenance mode.

3.17 Equipment Error Code Indication

■ Function

This function displays an error code of the last error on the LCD.

■ Operating Procedure

- (1) Press the **8** and **2** keys in this order in the initial stage of the maintenance mode.
The LCD shows the "MACHINE ERROR XX."
- (2) To stop this operation and return the equipment to the initial stage of the maintenance mode, press the **Stop** key.

3.18 Output of Transmission Log to the Telephone Line

■ Function

This function outputs the transmission log (that the equipment has stored about the latest transmission) to the telephone line. It allows the service personnel to receive the transmission log of the user's equipment at a remote location and use it for analyzing problems arising in the user's equipment.

■ Operating Procedure

- (1) If the user's equipment has a transmission-related problem, call the user's equipment at a remote location from your equipment.
- (2) If the line is connected, have the user perform the following:
 - 1) American models: Press the **Function**, **Receive Mode**, and **0** keys in this order.
European models: Press the **Menu**, **Receive Mode**, and **0** keys in this order.
 - 2) Press the **8** and **7** keys in this order.
The above operation makes the user's equipment send CNG to your equipment for sending the transmission log.
- (3) If you hear the CNG sent from the user's equipment, press the **Start** key of your equipment.
Your equipment will start to receive the transmission log from the user's equipment.

3.19 Cancellation of the Pin TX Lock Mode (Not applicable to American models)

■ Function

This procedure can cancel the Pin TX lock mode. Use this procedure if the user forgets his/her password entered when setting the Pin TX lock mode so as not to exit from the mode.

NOTE: Carrying out this procedure will lose passwords previously entered but retain FAX messages received in the Pin TX lock mode.

■ Operating Procedure

- (1) When the PIN TX LOCK is displayed on the LCD, hold down the **Menu** key and press the **#** key. Within two seconds, start to press the **2, 7, 9, 0,** and **0** keys.

The Pin TX lock mode will be canceled and the equipment returns to the calendar clock screen.

1. ERROR INDICATION

To help the user or the service personnel promptly locate the cause of a problem (if any), the facsimile equipment incorporates the self-diagnostic functions which display error messages for equipment errors and communications errors.

For the communications errors, the equipment also prints out the transmission verification report and the communications list.

1.1 Equipment Errors

If an equipment error occurs, the facsimile equipment emits an audible alarm (continuous beeping) for approximately 4 seconds and shows the error message on the LCD. For the error messages, see [1] below.

To display detailed error information, use the maintenance-mode function code 82 described in Chapter V, Section 3.17 (that is, make the equipment enter the maintenance mode and then press the **8** and **2** keys). Following the MACHINE ERROR, one of the error codes listed in [2] will appear on the LCD.

[1] Error messages on the LCD

Messages on the LCD	Probable Cause
CHECK PAPER	The registration sensor detects no recording paper loaded in the auto sheet feeder (ASF).
PRINTER JAM	The paper ejection sensor detects that a paper jam has occurred.
COVER OPEN	The cover/panel open sensor detects that the top cover or control panel is not closed.
DOCUMENT JAM	<ul style="list-style-type: none">■ Document jam(1) The document length exceeds the limitation (400 or 90 cm) registered by firmware switch WSW16. (Refer to Chapter V, Section 3.5.) (Both the document front and rear sensors stay ON even after the document has been fed by the registered length.)(2) The document rear sensor detects no trailing edge of a document after the document has been fed by 400 cm. (The document rear sensor stays ON even after the document has been fed when the document front and rear sensors were OFF and ON, respectively.)

Messages on the LCD	Probable Cause
DOCUMENT JAM	<ul style="list-style-type: none"> ■ Document loading error (1) The document rear sensor detects no leading edge of a document within 10 seconds from the start of document loading operation. (The document rear sensor stays OFF even after the document has been fed when the document front sensor was ON.) (2) The loaded document is too short. (Since the document is shorter than the distance between the document front and rear sensors, the document front sensor is turned OFF before the document rear sensor is turned ON.)
CLEAN UP SCANNER	In the scanning compensation data list printed by the maintenance-mode function code 05 (refer to Chap. V, Section 3.2), less than fifty percent of the white level data is faulty. (This message may appear only in the maintenance mode)
SCANNER ERROR	In the scanning compensation data list printed by the maintenance-mode function code 05 (refer to Chap. V, Section 3.2), fifty percent or more of the white level data is faulty. (This message may appear only in the maintenance mode)
NEAR EMPTY CYAN NEAR EMPTY MGENT	The ink dot counter (for cyan or magenta) in the EEPROM on the right print head has counted up the specified number of dots, meaning near empty of ink. Even if either of these messages is displayed, color printing is still possible.
NEAR EMPTY YELLW NEAR EMPTY BLACK	The ink dot counter (for yellow or black) in the EEPROM on the left print head has counted up the specified number of dots, meaning near empty of ink. Even if either of these messages is displayed, color printing is still possible.
INK EMPTY CYAN INK EMPTY MAGENT	The ink dot counter (for cyan or magenta) in the EEPROM on the right print head has counted up the specified number of dots, meaning that the ink has run out. Once either of these messages is displayed, color printing is no longer possible. (If black ink remains, printing of the received data record or monochrome copying is possible.)
INK EMPTY YELLOW INK EMPTY BLACK	The ink dot counter (for yellow or black) in the EEPROM on the left print head has counted up the specified number of dots, meaning that the ink has run out. Once either of these messages is displayed, color printing is no longer possible. (If black ink remains, printing of the received data record or monochrome copying is possible.) NOTE: For checking how much the black ink remains accurately, the controller compensates the ink dot count with the black ink empty sensor.

Messages on the LCD	Probable Cause
SET CARTRIDGES	Any one of the four ink cartridge sensors detects no ink cartridge loaded.
WARMING UP	The temperature inside the equipment has dropped to 5.5°C or below after two hours of powering-on state, or it has dropped to 3.5°C or below within two hours of powering-on state.
COOLING DOWN	The temperature inside the equipment has exceeded 48°C.
PLS OPEN COVER	To display the relating detailed error code, use maintenance-mode function code 82. (Refer to Chapter V, Section 3.17.) If this message appears, open and close the top cover and control panel. The message may disappear if opening/closing the top cover or control panel removes the error. If the error persists, the "MACHINE ERROR <u>X</u> <u>X</u> " will appear instead of this message.
PC BUSY OR FAIL	After connected with the host computer, the equipment has received no response from the computer. (A communications error has occurred.)
MEDIA ERROR	<ul style="list-style-type: none"> • The inserted media is broken or not formatted. • The equipment cannot access the designated file since no media is inserted or the inserted media is removed during access.
NO FILE	The designated image file is damaged, or the file is not an image file even if its extension is .JPG.

If only an alarm beep is heard without any message on the LCD when the equipment is turned on, the ROM or RAM will be defective.

[2] Error codes shown in the "MACHINE ERROR X X" message

If the LCD shows the "PLS OPEN COVER" message, you can display the detailed error code following the MACHINE ERROR, by using the maintenance-mode function code 82 described in Chapter V, Section 3.17.

NOTE: When checking a PCB as instructed in the "Check:" column, check its harness also.

NOTE: To check sensors, use the maintenance-mode function code 32 described in Chapter V, Section 3.9 (that is, press the **3** and **2** keys in the maintenance mode).

Error Code (Hex)	Error factor	Check:
23	Printer engine timeout.	• Main PCB
25	Ink cartridges had already been loaded when the power was first applied.	Reload ink cartridges, referring to the Owner's Manual.
26	The black ink has run out.	• Black ink cartridge
27	The yellow ink has run out.	• Yellow ink cartridge
28	The cyan ink has run out.	• Cyan ink cartridge
29	The magenta ink has run out.	• Magenta ink cartridge
2A	No black ink cartridge is loaded.	• Black ink cartridge
2B	No yellow ink cartridge is loaded.	• Yellow ink cartridge
2C	No cyan ink cartridge is loaded.	• Cyan ink cartridge
2D	No magenta ink cartridge is loaded.	• Magenta ink cartridge
30	The carriage cannot travel to the right or left.	<ul style="list-style-type: none"> • Carriage ASSY • Encoder strip (Any stains or scratches? Hooked correctly?) • Carriage motor • Main PCB • Power supply PCB • Purge unit • Main chassis
31	After driven by the specified number of pulses, the carriage does not stop (since it cannot detect the left end of the travel).	
32	The carriage movement parameter exceeded the travel range during printing.	
33	The carriage cannot move in midway of travel.	
34	The carriage stops during the short travel.	
35	The carriage stops during low-speed travel.	
36	The carriage stop position is out of the travel range.	
37	The carriage speed exceeds the allowable limit.	
38	The carriage speed drops below the allowable limit during constant-speed travel.	
39	The carriage has overridden the travel range.	
3B	Printing area error.	
3C	Sudden carriage stop during printing.	

Error Code (Hex)	Error factor	Check:
41	The head drive voltage has not been turned from Low to High within the specified time.	<ul style="list-style-type: none"> • Carriage ASSY • Main PCB • Print head unit • Power supply PCB
42	The head drive voltage has not been turned from High to Low within the specified time.	
43	Head thermistor broken.	<ul style="list-style-type: none"> • Print head unit • Carriage ASSY • Main PCB
44	Head thermistor short-circuited.	
45	Flushing operation abnormally ended. (The head temperature has arisen abnormally.)	<ul style="list-style-type: none"> • Print head unit
46	The number of performed purge sequences has reached the limit.	<ul style="list-style-type: none"> • Ink absorber box • Main PCB
47	Head parameter stored in the EEPROM on either of the two print heads is invalid. (This code may appear only in the maintenance mode.)	<ul style="list-style-type: none"> • Print head unit • Main PCB • Power supply PCB
4B	Abnormal carriage travel speed detected when the power was applied.	<ul style="list-style-type: none"> • Encoder strip (Any stains or scratches? Hooked correctly?) • Purge unit • Main chassis • Carriage ASSY • Main PCB
4D	Error of the reference voltage in the video capture circuit.	<ul style="list-style-type: none"> • Main PCB
4E	Out of the allowable range of the head drive voltage designed for individual print head properties.	<ul style="list-style-type: none"> • Main PCB • Print head unit
50	The purge cam HP switch does not come ON even after the purge cam has been driven by the specified number of pulses.	<ul style="list-style-type: none"> • Purge unit • Purge-related gears on the main chassis (Purge gears 18 and 19, gear stopper, and purge bevel gear 18) • Main chassis • Paper feed motor • Main PCB
51	The purge cam HP switch does not go OFF even after the purge cam has been driven by the specified number of pulses.	
52	The pump switching cam HP switch does not come ON even after the switching cam has been driven by the specified number of pulses.	
53	The pump switching cam HP switch does not go OFF even after the switching cam has been driven by the specified number of pulses.	
54	When the machine was placed in the ink replacement mode, the carriage was moved by hand to the right and out of the replacement position.	
		<ul style="list-style-type: none"> • Restart the machine.

Error Code (Hex)	Error factor	Check:
7D	Any of the ink dot counters has counted up to the specified number of dots, meaning the end of the head service life.	<ul style="list-style-type: none"> • Print head unit • Ink absorber
7E	No print head unit is detected.	<ul style="list-style-type: none"> • Print head unit • Carriage PCB • Head flat cables • Main PCB
7F	Print engine error.	<ul style="list-style-type: none"> • Main PCB
82	Recording paper feeding error.	<ul style="list-style-type: none"> • ASF • Registration sensor actuator • Main PCB
83	Recording paper jam. (The registration sensor sticks to OFF, indicating that paper has jammed.)	<ul style="list-style-type: none"> • Registration sensor actuator • Main PCB
84	Recording paper jam. (The paper ejection sensor has detected a paper jam.)	<ul style="list-style-type: none"> • Paper ejection sensor actuator • Registration sensor actuator • Main PCB
88	Recording paper jam. (Even after the registration sensor has come ON, the paper ejection sensor does not detect paper.)	
A1	Top cover or control panel opened.	<ul style="list-style-type: none"> • Cover open sensor actuator • Panel open sensor actuator • Main PCB • Top cover and control panel
A2	Document too long to scan.	<ul style="list-style-type: none"> • Document front sensor actuator • Document rear sensor actuator • Control panel PCB • Document sensor PCB • Document feed roller • Scanner motor • Main PCB
A3	Document not detected by the document rear sensor.	
A4	50% or more faulty of white level data.	<ul style="list-style-type: none"> • CIS unit • Main PCB

Error Code (Hex)	Error factor	Check:
A7	One-line feeding timeout.	
A8	One-line scanning timeout.	
AC	Less than 50% faulty of white level data.	<ul style="list-style-type: none"> • CIS unit • Main PCB
B7	A/D voltage regulation error (Exceeding the upper limit).	<ul style="list-style-type: none"> • CIS unit • Main PCB
B8	A/D voltage regulation error (Dropping below the lower limit).	
B9	Light emission intensity error of the LED array (Exceeding the upper limit).	<ul style="list-style-type: none"> • CIS unit • Main PCB
BB	White level data value too low.	
BD	Black level data value too high.	
D*	Modem error.	<ul style="list-style-type: none"> • Main PCB
E4	Out of recording paper.	<ul style="list-style-type: none"> • ASF • Registration sensor actuator • Document feed roller • Main PCB
E6	Write error in EEPROM.	<ul style="list-style-type: none"> • Main PCB
E8	Data scanning error during transmission.	<ul style="list-style-type: none"> • CIS unit • Main PCB
EA	Document removed at phase B.	
F1 F3 F5	Internal software error.	<ul style="list-style-type: none"> • Replace the main PCB if this error occurs frequently.
F6	PC interface error.	<ul style="list-style-type: none"> • Interface cable • Main PCB
FF	Memory management error.	<ul style="list-style-type: none"> • Replace the main PCB if this error occurs frequently.

1.2 Communications Errors

If a communications error occurs, the facsimile equipment

- ① emits an audible alarm (intermittent beeping) for approximately 4 seconds,
- ② displays the corresponding error message, and
- ③ prints out the transmission verification report if the equipment is in sending operation.

■ **Definition of Error Codes on the Communications List**

(1) Calling

Code 1	Code 2	Causes
10	08	Wrong number called.
11	01	No dial tone detected before start of dialing.
11	02	Busy tone detected before dialing.
11	03	2nd dial tone not detected.
11	05	No loop current detected.*
11	06	Busy tone detected after dialing or called.
11	07	No response from the remote station in sending.
11	10	No tone detected after dialing.
17	07	No response from the calling station in receiving.

*Available in German versions only.

(2) Command reception

Code 1	Code 2	Causes
20	01	Unable to detect a flag field.
20	02	Carrier was OFF for 200 ms or longer.
20	03	Abort detected ("1" in succession for 7 bits or more).
20	04	Overrun detected.
20	05	A frame for 3 seconds or more received.
20	06	CRC error in answerback.
20	07	Undefined command received.
20	08	Invalid command received.
20	09	Command ignored once for document setting or for dumping-out at turn-around transmission.
20	0A	T5 time-out error
20	0B	CRP received.
20	0C	EOR and NULL received.

(3) Compatibility [checking the NSF and DIS]

Code 1	Code 2	Causes
32	01	Remote terminal only with V.29 capability in 2400 or 4800 bps transmission.
32	02	Remote terminal not ready for polling.
32	10	Remote terminal not equipped with password function or its password switch OFF.
32	11	Remote terminal not equipped with or not ready for confidential mail box function.
32	12	Remote terminal not equipped with or not ready for relay broadcasting function.
32	13	No confidential mail in the remote terminal.
32	14	The available memory space of the remote terminal is less than that required for reception of the confidential or relay broad-casting instruction.
32	18	Remote terminal not equipped with color function.

(4) Instructions received from the remote terminal [checking the NSC, DTC, NSS, and DCS]

Code 1	Code 2	Causes
40	02	Illegal coding system requested.
40	03	Illegal recording width requested.
40	05	ECM requested although not allowed.
40	06	Polled while not ready.
40	07	No document to send when polled.
40	10	Nation code or manufacturer code not coincident.
40	11	Unregistered group code entered for relay broadcasting function, or the specified number of broadcasting subscribers exceeding the limit.
40	12	Retrieval attempted when not ready for retrieval.
40	13	Polled by any other manufacturers' terminal while waiting for secure polling.
40	17	Invalid resolution selected.
40	20	Invalid full-color mode requested.

(5) Command reception [checking the NSF and DIS after transmission of NSS and DCS]

Code 1	Code 2	Causes
50	01	Vertical resolution capability changed after compensation of background color.

(6) ID checking

Code 1	Code 2	Causes
63	01	Password plus "lower 4 digits of telephone number" not coincident.
63	02	Password not coincident.
63	03	Polling ID not coincident.
63	04	Entered confidential mail box ID uncoincident with the mail box ID.
63	05	Relay broadcasting ID not coincident.
63	06	Entered retrieval ID uncoincident with that of the mail box ID.

(7) DCN reception

Code 1	Code 2	Causes
74		DCN received.

(8) TCF transmission/reception

Code 1	Code 2	Causes
80	01	Fallback impossible.

(9) Signal isolation

Code 1	Code 2	Causes
90	01	Unable to detect video signals and commands within 6 seconds after CFR is transmitted.
90	02	Received PPS containing invalid page count or block count.

(10) Video signal reception

Code 1	Code 2	Causes
A0	03	Error correction sequence not terminated even at the final transmission speed for fallback.
A0	11	Receive buffer empty. (5-second time-out)
A0	12	Receive buffer full during operation except receiving into memory.
A0	13	Decoding error continued on 500 lines.
A0	14	Decoding error continued for 10 seconds.
A0	15	Time-out: 5 seconds or more for one-line transmission.
A0	16	RTC not found and carrier OFF signal detected for 6 seconds.
A0	17	RTC found but no command detected for 60 seconds.
A0	18	Receive buffer full during receiving into memory.
A0	19	No video data to be sent
A0	20	Unable to continue to receive color FAX (Remaining ink insufficient)
A8	01	RTN, PIN, or ERR received at the calling terminal.*
A9	01	RTN, PIN, or ERR received at the called terminal.*

* Available in German versions only

(11) General communications-related

Code 1	Code 2	Causes
B0	02	Unable to receive the next-page data.
B0	03	Unable to receive polling even during turn-around transmission due to call reservation.
B0	04	PC interface error.

(12) Maintenance mode

Code 1	Code 2	Causes
E0	01	Failed to detect 1300 Hz signal in burn-in operation.
E0	02	Failed to detect PB signals in burn-in operation.

(13) Equipment error

Code 1	Code 2	Causes
FF	<u>X</u> <u>X</u>	Equipment error (For <u>X</u> <u>X</u> , refer to Section 1.1 [2].)

2. TROUBLESHOOTING

2.1 Introduction

This section gives the service personnel some of the troubleshooting procedures to be followed if an error or malfunction occurs with the facsimile equipment. It is impossible to anticipate all of the possible problems which may occur in future and determine the troubleshooting procedures, so this section covers some sample problems. However, those samples will help service personnel pinpoint and repair other defective elements if he/she analyzes and examines them well.

2.2 Precautions

Be sure to observe the following to prevent the secondary troubles from happening:

- (1) Always unplug the AC power cord from the outlet when removing the covers and PCBs, adjusting the mechanisms, or conducting continuity testing with a circuit tester.
- (2) When disconnecting the connectors, do not pull the lead wires but hold the connector housings.
- (3)
 - Before handling the PCBs, touch a metal portion of the machine to discharge static electricity charged in your body.
 - When repairing the PCBs, handle them with extra care.

After repairing the defective section, be sure to check again if the repaired section works correctly. Also record the troubleshooting procedure so that it would be of use for future trouble occurrence.

2.3 Checking prior to Troubleshooting

Prior to proceeding to the troubleshooting procedures given in Subsection 2.4, make the following initial checks:

Environmental conditions

Check that:

- (1) The machine is placed on a flat, firm surface.
- (2) The machine is used in a clean environment at or near normal room temperature (10°C to 35°C) with normal relative humidity (20 to 80%).
- (3) The machine is not exposed to direct sunlight or harmful gases.

Power requirements

Check that:

- (1) The power supply specified on the rating plate located on the bottom of the machine is used. The supply voltage stays within the rating $\pm 10\%$.
- (2) Each voltage level on AC input lines and DC lines is correct.
- (3) All cables and harnesses are firmly connected.
- (4) None of the fuses are blown.

Recording paper

Check that:

- (1) A recommended type of recording paper is used.
- (2) The recording paper is not dampened.

Ink cartridges

- (1) Check that all of four ink cartridges are loaded.

Print head

- (1) Check that both the right and left print heads are installed on the carriage correctly. (Check the dimple contact between the print head PCB and the carriage PCB.)
- (2) Repeat the head purging operation several times.

2.4 Troubleshooting Procedures

[1] Control panel related

Trouble	Check:
(1) LCD shows nothing.	<ul style="list-style-type: none">• Panel-main harness• Control panel PCB• Power supply PCB• Main PCB
(2) Control panel inoperative.	<ul style="list-style-type: none">• Panel-main harness• Control panel PCB• FPC key• Main PCB

[2] Telephone related

Trouble	Check:
(1) No phone call can be made.	<ul style="list-style-type: none">• FPC key• Hook switch PCB• Control panel PCB• NCU PCB• Main PCB
(2) Speed dialing or one-touch dialing will not work.	<ul style="list-style-type: none">• Ordinary dialing function (other than the speed and one-touch dialing) <p>If it works normally, check the main PCB; if not, refer to item (1) above.</p>
(3) Speaker silent during on-hook dialing.	<ul style="list-style-type: none">• Ordinary dialing function (Pick up the handset and press the numerical keys.) <p>If it works normally, proceed to the following checks; if not, refer to item (1) above.</p> <ul style="list-style-type: none">• Speaker
(4) Dial does not switch between tone and pulse.	<ul style="list-style-type: none">• Main PCB

Trouble	Check:
(5) Telephone does not ring.	<ul style="list-style-type: none"> • Speaker • NCU PCB • Main PCB

[3] Communications related

Trouble	Check:
(1) No tone is transmitted.	<ul style="list-style-type: none"> • Main PCB • NCU PCB



[4] Paper/document feeding related

Trouble	Check:
(1) Neither "COPY: PRESS COPY" nor "FAX: NO. & START" message appears although documents are set.	<ul style="list-style-type: none"> • Sensors by using the maintenance-mode function code 32. (Refer to Chapter V, Section 3.9.) • Document front sensor actuator and document rear sensor actuator • Main PCB
(2) Document not fed.	<ul style="list-style-type: none"> • ADF and its related sections • Scanner motor and its harness • Document feed rollers and their related gears • Main PCB
(3) Document double feeding	<ul style="list-style-type: none"> • ADF parts
(4) Document jam	<ul style="list-style-type: none"> • Scanner motor
(5) Recording paper not fed.	<ul style="list-style-type: none"> • ADF-related gears • Main PCB
(6) Recording paper jam	<ul style="list-style-type: none"> • Paper feeding mechanism (PF timing belts and tension plate) • Eccentric bushing R and L (Alignment with markings made on the main chassis)



[5] Print-image related

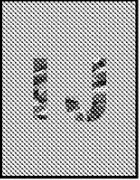

If the received or sent image has any problem, first make a copy with the facsimile equipment.

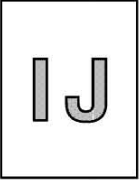
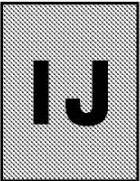
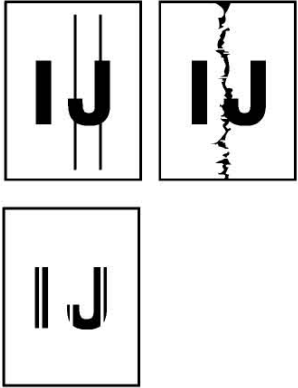
If the copied image is normal, the problem may be due to the remote terminal; if it is abnormal, proceed to the following checks:

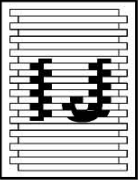
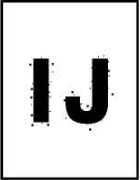
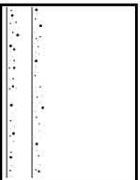
Trouble	Action to be taken
<p>(1) Completely blank</p> 	<p><u>At the scanner</u></p> <p>Check the following components:</p> <ul style="list-style-type: none"> - CIS harness - Main PCB - CIS unit
<p>(2) Random color</p> 	<p><u>At the printer</u></p> <ul style="list-style-type: none"> • Check the ink cartridges. If any cartridges have run out of ink, replace them. • Check the dimple contact between each of the print head PCBs and the mating carriage FPC. Clean it if contaminated. (If the problem persists, replace the carriage ASSY.) • Check the connection of the head flat cables on the main PCB. (If either of those cables is broken or damaged, replace it.) • Replace the main PCB.
<p>(3) All black</p> 	<p><u>At the scanner</u></p> <p>Check the following components:</p> <ul style="list-style-type: none"> - CIS harness - CIS unit - Main PCB <p><u>At the printer</u></p> <p>Check the following components:</p> <ul style="list-style-type: none"> - Print head unit - Main PCB - Carriage ASSY

Trouble	Action to be taken
<p>(4) Light</p> 	<p><u>At the scanner</u></p> <p>Check the following components:</p> <ul style="list-style-type: none"> - CIS unit - Main PCB <p><u>At the printer</u></p> <p>Check the following components:</p> <ul style="list-style-type: none"> - Ink cartridges - Print head unit - Main PCB - Power supply PCB
<p>(5) Dark</p> 	<p><u>At the scanner</u></p> <p>Check the following components:</p> <ul style="list-style-type: none"> - CIS unit - Main PCB <p><u>At the printer</u></p> <ul style="list-style-type: none"> • For each of the four ink-jet units, perform the head purging operation several times to remove dust or air bubbles from its nozzles. If the problem persists, replace the print head unit. • Check the paper feed-related rollers. • Replace the main PCB and power supply PCB.
<p>(6) Black or blurred vertical stripes</p> 	<p><u>At the scanner</u></p> <p>Check the following components:</p> <ul style="list-style-type: none"> - CIS unit <p><u>At the printer</u></p> <ul style="list-style-type: none"> • Check whether paper is in abnormal contact with any other components during ejecting. • Check the encoder strip for stains or scratches. (If the encoder strip is not hooked properly, correct it.)

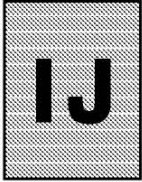
Trouble	Action to be taken
<p>(7) Print edges not aligned</p> 	<p><u>At the printer</u></p> <ul style="list-style-type: none"> • Check the alignment of vertical print lines by using the maintenance-mode function code 65. (Refer to Chapter V, Section 3.14). • Check the print head unit. • Check the encoder strip for stains or scratches. (If the encoder strip is not hooked properly, correct it.)
<p>(8) Ink splash</p>  	<p><u>At the printer</u></p> <ul style="list-style-type: none"> • For each of the four ink-jet units, perform the head purging operation several times to remove dust or air bubbles from its nozzles. • Check the ink cartridges. Any of them has run out of ink or the ink viscosity has been increased, so replace it. • Replace the print head unit. • Replace the main PCB. • Replace the power supply PCB. • Check that the eccentric bushings R and L are aligned with markings made on the main chassis to adjust the head-platen gap.
<p>(9) Random missing dots</p> 	<p><u>At the printer</u></p> <ul style="list-style-type: none"> • For each of the four ink-jet units, perform the head purging operation several times to remove dust or air bubbles from its nozzles. • Check the ink cartridges. If any cartridges have run out of ink, replace them. • Check the dimple contact between each of the print head PCBs and the mating carriage FPC. Clean it if contaminated. • Replace the print head unit (a set of the right and left print heads). (If the problem persists, replace the carriage ASSY.) • Check the connection of the head flat cables on the main PCB. (If either of those cables is broken or damaged, replace it.) • Replace the main PCB. • Clean the purge cap of the purge unit with the head cleaner. If the wiper or the pump of the purge unit is defective, replace the purge unit.)

Trouble	Action to be taken
<p>(10) White horizontal streaks</p> 	<ul style="list-style-type: none"> • For each of the four ink-jet units, perform the head purging operation several times to remove dust or air bubbles from its nozzles. • Replace the print head unit. • Check the paper feed-related rollers.
<p>(11) Stained leading edge of recording paper</p> 	<p><u>At the printer</u></p> <ul style="list-style-type: none"> • Clean the nozzle ends of the ink-jet units. • Check that the eccentric bushings R and L are aligned with markings made on the main chassis to adjust the head-platen gap.

[6] PC-driven or video capture-driven printing

Trouble	Check:
<p>(1) PC-driven printing is impossible.</p>	<ul style="list-style-type: none"> • Interface with the host computer • PC interface cable • Main PCB • Centronics interface
<p>(2) Video capture-driven printing is impossible</p>	<ul style="list-style-type: none"> • VC connector PCB • Main PCB • Centronics interface
<p>(3) Video printing is impossible.</p>	<ul style="list-style-type: none"> • VC connector PCB • Main PCB

[7] SmartMedia-driven or Compact Flash-driven printing

Trouble	Check:
(1) No image data can be read.	<ul style="list-style-type: none">• SmartMedia<ul style="list-style-type: none">- Inserted with its face up?• SmartMedia or Compact Flash<ul style="list-style-type: none">- Formatted?- Any data in the media?- Images stored in the media are in EXIF2.0-compliant JPEG file format (having extension .JPG)?• Media PCB• Media flat cables• Main PCB
(2) No SmartMedia can be recognized.	<ul style="list-style-type: none">• Check whether Compact Flash card is already inserted. If not, refer to item (1) above.
(3) Media printing is impossible.	<ul style="list-style-type: none">• Check whether video signals are inputted to the VC terminal.• Check whether a document is set on the ADF .• Check whether the memory is full.

EEPROM Customizing Codes

This function allows you to customize the EEPROM according to language, function settings, and firmware switch settings.

■ Operating Procedure

- (1) American models: Press the **Function**, *, **2**, **8**, **6**, and **4** keys in this order to make the facsimile equipment enter the maintenance mode.

European models: Press the **Menu**, *, **2**, **8**, **6**, and **4** keys in this order to make the facsimile equipment enter the maintenance mode.

The equipment beeps for approx. one second and displays " ■■ MAINTENANCE ■■■ " on the LCD.

- (2) Press the **7** and **4** keys in this order in the initial stage of the maintenance mode.
The current customizing code (e.g., 9101 in the case of MFC7400C U.S.A. versions) appears.
- (3) Enter the desired customizing code (e.g., 0102 in the case of MFC7400C Canadian versions).
The newly entered code appears.

NOTE: If a wrong 4-digit code is entered, the equipment will malfunction.

- (4) Press the **Start** key.
The equipment saves the setting and returns to the initial stage of the maintenance mode.
- If you press the **Stop** key or no keys are pressed for one minute in the above procedure, the equipment stops the procedure and returns to the initial stage of the maintenance mode.

■ EEPROM Customizing Codes List

(1) MFC7300C/MFC7400C

Versions	Model	
	MFC7300C	MFC7400C
U.S.A.	9001	9101
Canada	0002	—
Australia	0006	0106
New Zealand	—	0127
Asia	—	0140

(2) MFC830/MFC840

Versions	Model	
	MFC830	MFC840
Germany	8003	8103
U.K.	0002	0104
France	0006	0105
Norway	0007	0107
Belgium	8008	8108
Netherlands	—	0109
Switzerland	0010	0110
Ireland	—	0104
Denmark	8013	8113
Austria	8003	—
Spain	0015	0115
Italy	0016	0116
South Africa	0004	0104
Sweden	0026	0126

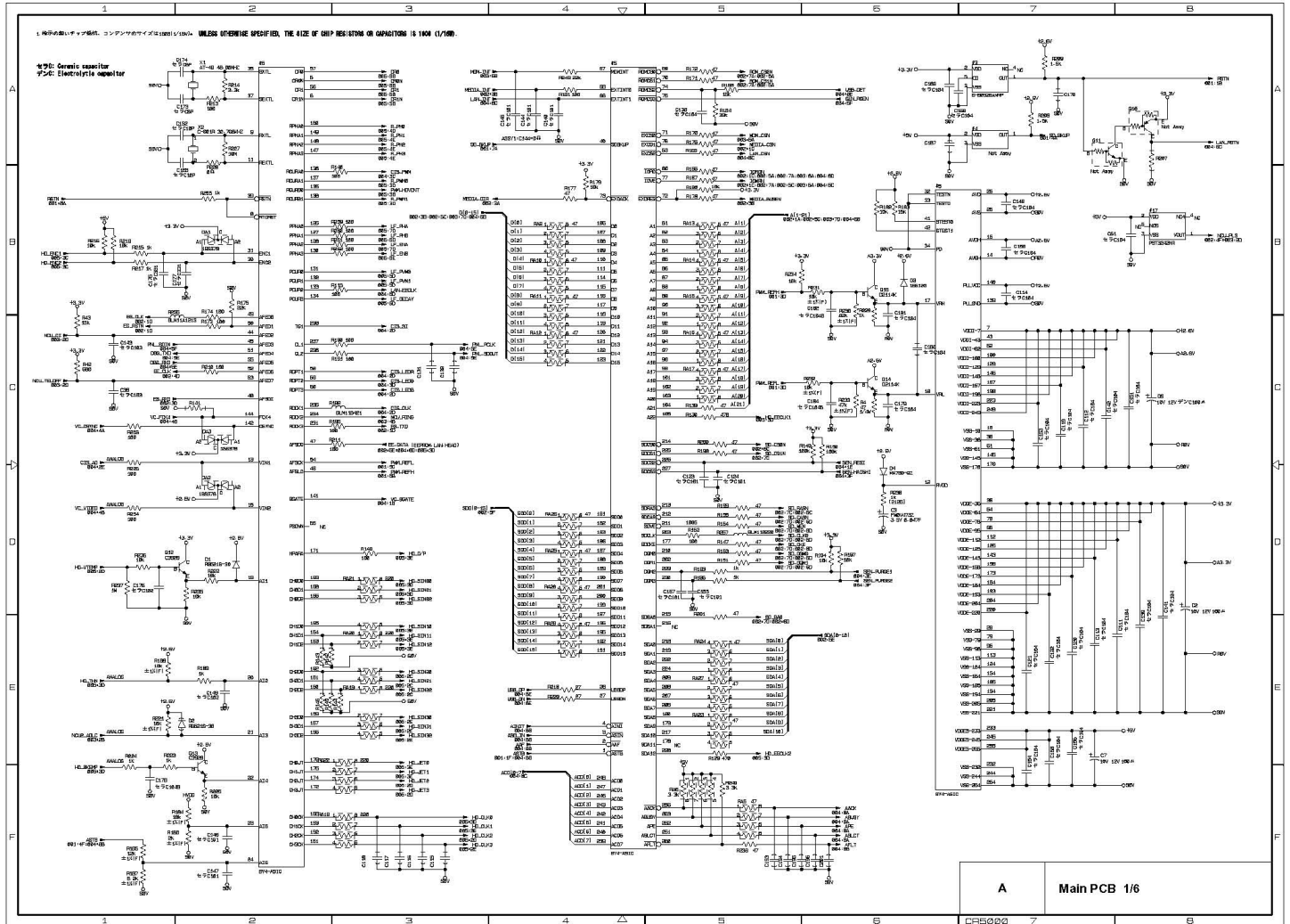

A Main PCB 1/6
CR5000

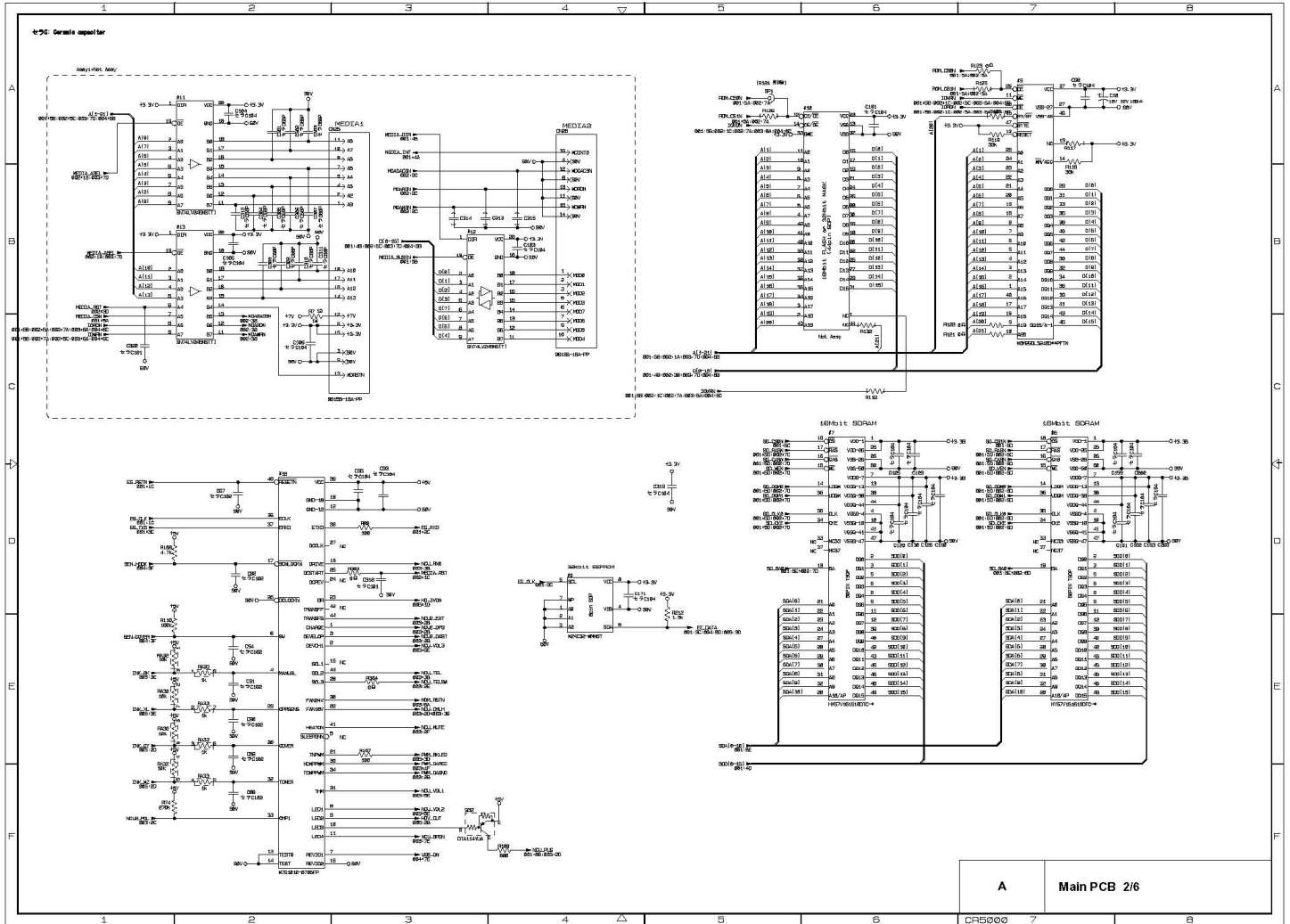

A Main PCB 2/6
CR5000

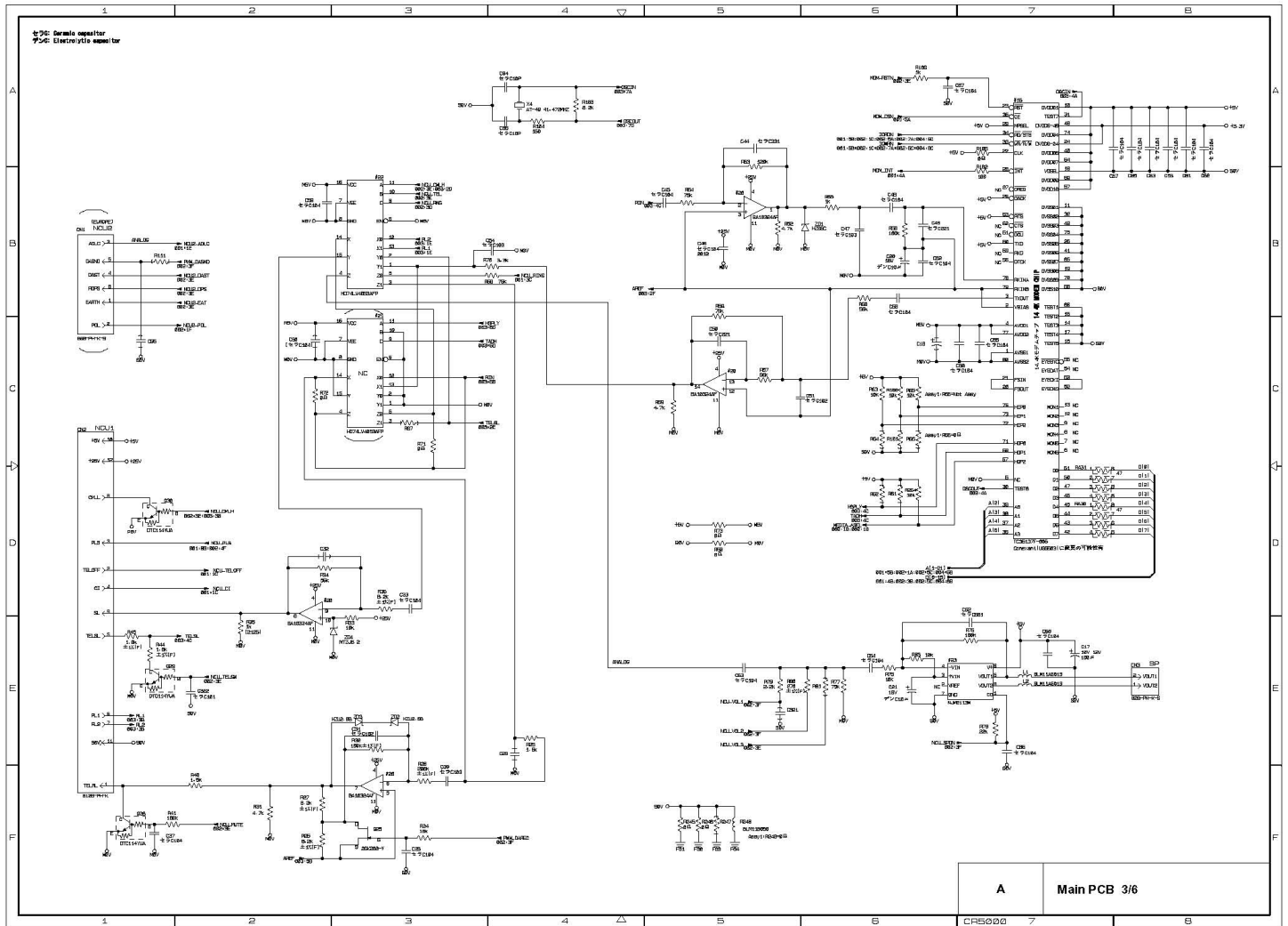

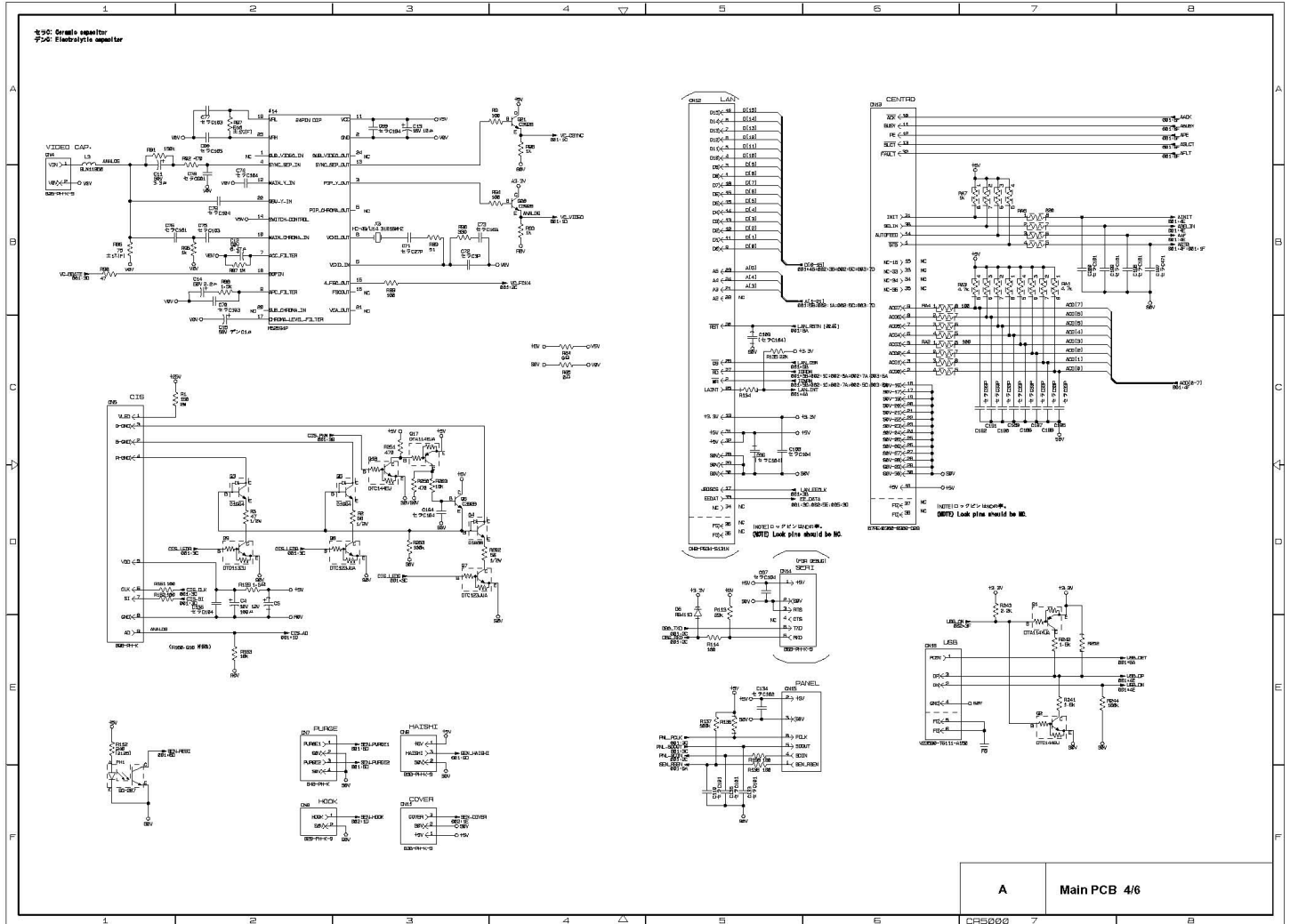

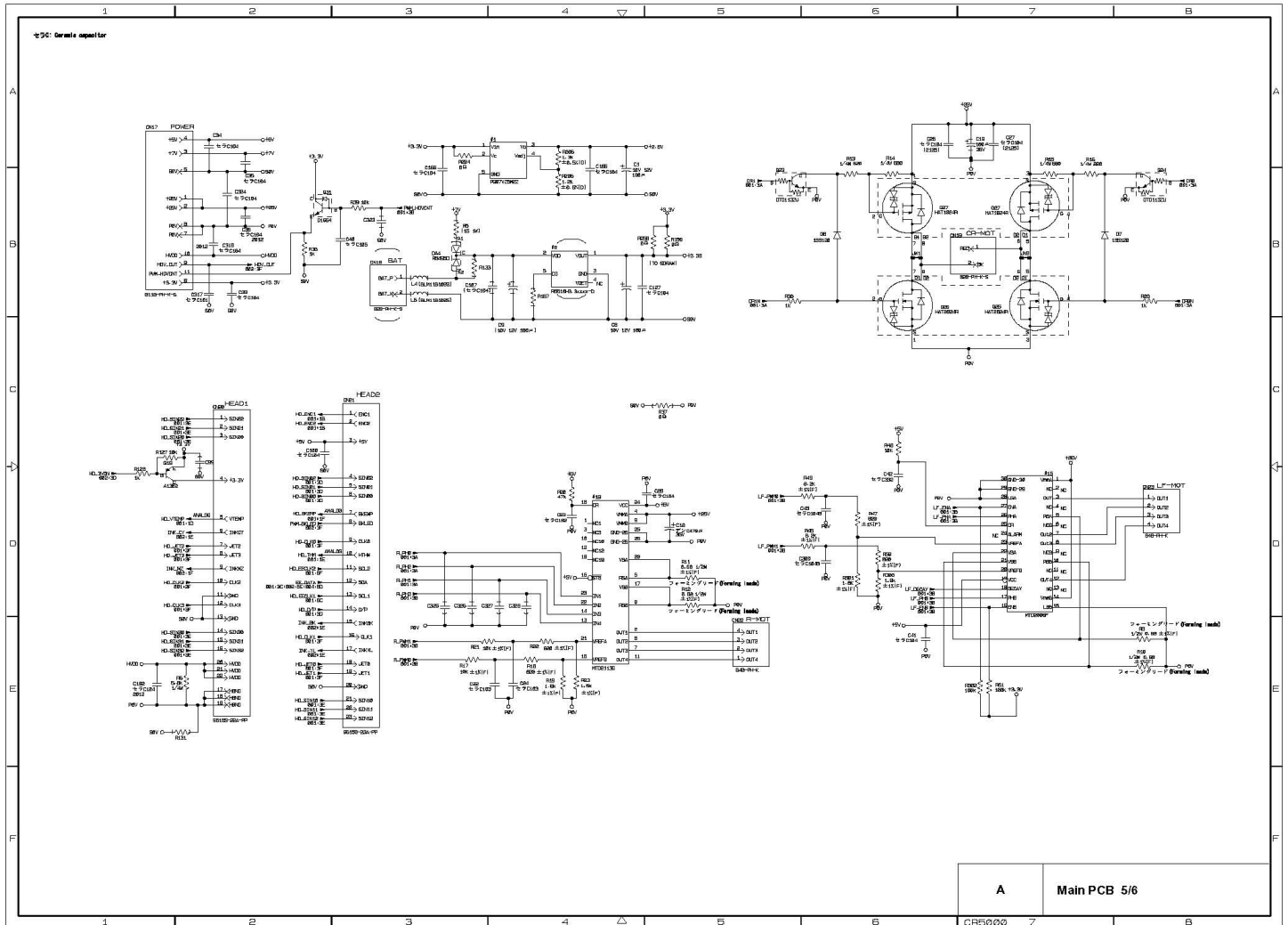

A Main PCB 5/6

BY4MFC MAIN CIRCUIT DIAGRAM

PAGE	NOTE	ADDRESS	MFC7300		MFC7400			
			ASSY1	ASSY21	ASSY2	ASSY31	ASSY33	ASSY34
			US	EUR	US	EUR/OCE	ASA	TWN
1	BACK-UP	C3	ALUM-ELEC 3.5B473	ALUM-ELEC 3.5B224	ALUM-ELEC 3.5B473	ALUM-ELEC 3.5B224	ALUM-ELEC 3.5B224	ALUM-ELEC 3.5B224
2	MEDIA	C318,C320	NOT ASSY	NOT ASSY	CC50C101	CC50C101	CC50C101	CC50C101
		R303	NOT ASSY	NOT ASSY	0Ω	0Ω	0Ω	0Ω
	NCU TELSW	R304	0Ω	NOT ASSY	0Ω	0Ω	0Ω	0Ω
3	NCU2	CN1	NOT ASSY	B6B-PH	NOT ASSY	B6B-PH	B6B-PH	B6B-PH
	SL	R36	8.2kΩ (F)	7.5kΩ (F)	8.2kΩ (F)	7.5kΩ (F)	7.5kΩ (F)	7.5kΩ (F)
		R34	56kΩ	56kΩ (F)	56kΩ	56kΩ (F)	56kΩ (F)	56kΩ (F)
	DASND	R111	NOT ASSY	NOT ASSY	NOT ASSY	NOT ASSY	10kΩ	10kΩ
		C95	NOT ASSY	NOT ASSY	NOT ASSY	NOT ASSY	CC25C104	CC25C104
	TEL SL	R44	1.8kΩ (F)	NOT ASSY	1.8kΩ (F)	NOT ASSY	NOT ASSY	NOT ASSY
		Q29	DTC114YUA+	NOT ASSY	DTC114YUA+	NOT ASSY	NOT ASSY	NOT ASSY
		R45	1.8kΩ (F)	NOT ASSY	1.8kΩ (F)	0Ω	0Ω	0Ω
	TEL RL	C30	CC50C103B	NOT ASSY	CC50C103B	CC25C104	CC50C103B	CC50C103B
		R28	200kΩ (F)	NOT ASSY	200kΩ (F)	47kΩ (F)	130kΩ (F)	130kΩ (F)
		R32	100kΩ (F)	39kΩ (F)	100kΩ (F)	39kΩ (F)	39kΩ (F)	39kΩ (F)
		R24	10kΩ	NOT ASSY	10kΩ	NOT ASSY	10kΩ	10kΩ
		C28	CC25C104	NOT ASSY	CC25C104	NOT ASSY	CC25C104	CC25C104
		R27	8.2kΩ (F)	0Ω	8.2kΩ (F)	0Ω	1kΩ (F)	1kΩ (F)
		R26	8.2kΩ (F)	NOT ASSY	8.2kΩ (F)	NOT ASSY	680Ω (F)	680Ω (F)
		Q25	2SK208-Y	NOT ASSY	2SK208-Y	NOT ASSY	2SK208GR	2SK208GR
		ZD2,ZD3	ZENER:HZU2.0B	NOT ASSY	ZENER:HZU2.0B	ZENER:HZU2.0B	ZENER:HZU2.0B	ZENER:HZU2.0B
		C31	CC50102B	NOT ASSY	CC50102B	CC50102B	CC50102B	CC50102B
		R31	4.7kΩ	NOT ASSY	4.7kΩ	4.7kΩ	4.7kΩ	4.7kΩ
		R40	1.5kΩ	NOT ASSY	1.5kΩ	1.5kΩ	1.5kΩ	1.5kΩ
	TEL MUTE	R41	100kΩ	NOT ASSY	100kΩ	100kΩ	100kΩ	100kΩ
C37		CC25C104	NOT ASSY	CC25C104	CC25C104	CC25C104	CC25C104	
Q28		DTC114YUA+	NOT ASSY	DTC114YUA+	DTC114YUA+	DTC114YUA+	DTC114YUA+	
TEL SW	C322	CC50C101	NOT ASSY	CC50C101	CC50C101	CC50C101	CC50C101	
4	VIDEO NTSC/PAL	X3	XTAL 14.31818MHz	XTAL 17734.476KHz	XTAL 14.31818MHz	XTAL 17734.476KHz	XTAL 17734.476KHz	XTAL 14.31818MHz
		R89	51Ω	0Ω	51Ω	0Ω	0Ω	51Ω
		C71	CC50C270CH	CC50C180CH	CC50C270CH	CC50C180CH	CC50C180CH	CC50C270CH
	HOOK	CN8	B2B-PH	NOT ASSY	B2B-PH	B2B-PH	B2B-PH	
5	POWER	C324	NOT ASSY	CC25C104	NOT ASSY	CC25C104	CC25C104	CC25C104

A

Main PCB 6/6

1. 指示ナキ抵抗ノ消費電力ハ1/4ワトスル。
1. UNLESS OTHERWISE SPECIFIED, POWER CONSUMPTION OF RESISTORS IS 1/4W.
2. 指示ナキコンデンサノ耐圧ハ2.5V又ハ50Vトスル。
2. UNLESS OTHERWISE SPECIFIED, THE VOLTAGE RESISTANCE OF CAPACITORS IS 25V OR 50V.
3. () 内ノ部品ハ未装トスル。
3. COMPONENTS IN PARENTHESIS NOT TO BE MOUNTED.

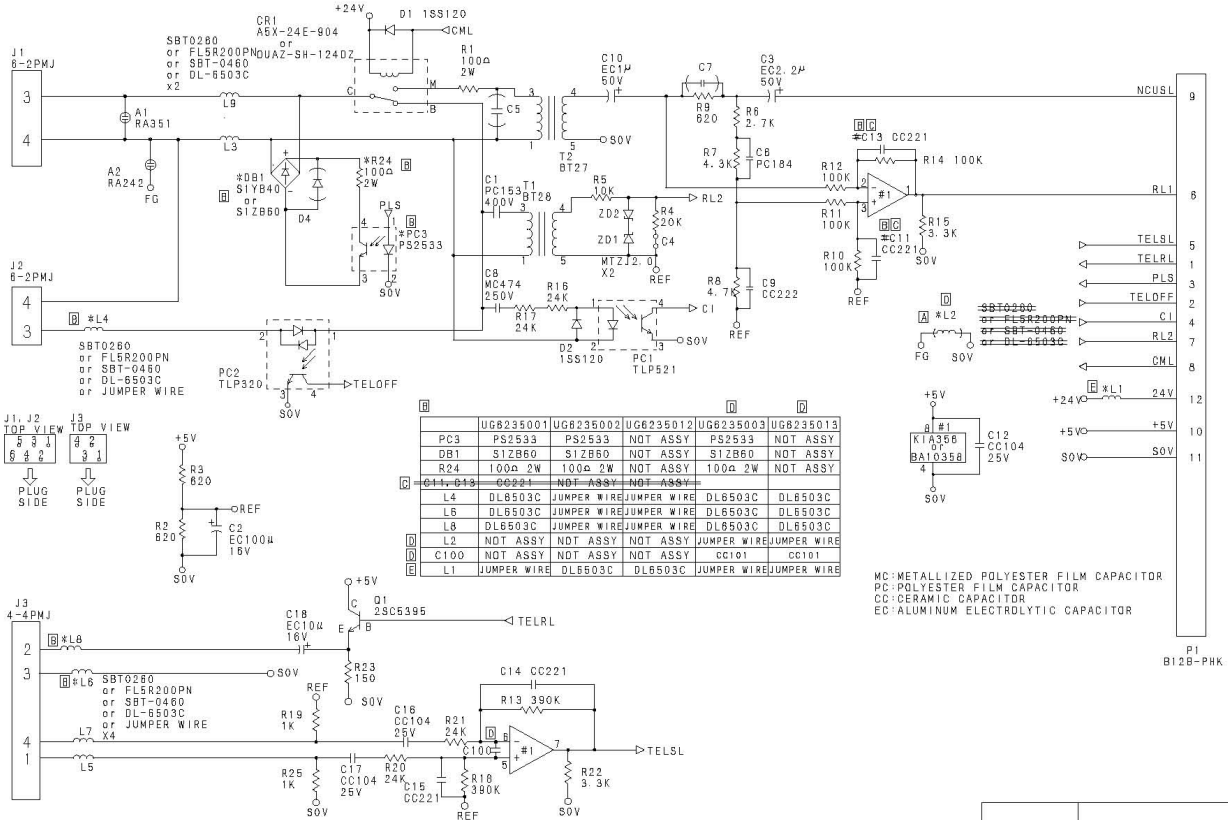

PC3	UG8235001	PS2533	PS2533	NOT ASSY	PS2533	NOT ASSY
DB1	S1ZB60	S1ZB60	S1ZB60	NOT ASSY	S1ZB60	NOT ASSY
R24	100Ω 2W	100Ω 2W	100Ω 2W	NOT ASSY	100Ω 2W	NOT ASSY
C11, C13	CC221	CC221	CC221	NOT ASSY	CC221	NOT ASSY
L4	DL6503C	JUMPER WIRE	JUMPER WIRE	DL6503C	DL6503C	
L6	DL6503C	JUMPER WIRE	JUMPER WIRE	DL6503C	DL6503C	
L8	DL6503C	JUMPER WIRE	JUMPER WIRE	DL6503C	DL6503C	
L2	NOT ASSY	NOT ASSY	NOT ASSY	JUMPER WIRE	JUMPER WIRE	
C100	NOT ASSY	NOT ASSY	NOT ASSY	CC101	CC101	
L1	JUMPER WIRE	DL6503C	DL6503C	JUMPER WIRE	JUMPER WIRE	

MC: METALLIZED POLYESTER FILM CAPACITOR
 PC: POLYESTER FILM CAPACITOR
 CC: CERAMIC CAPACITOR
 EC: ALUMINUM ELECTROLYTIC CAPACITOR

B NCU (U.S.A.)

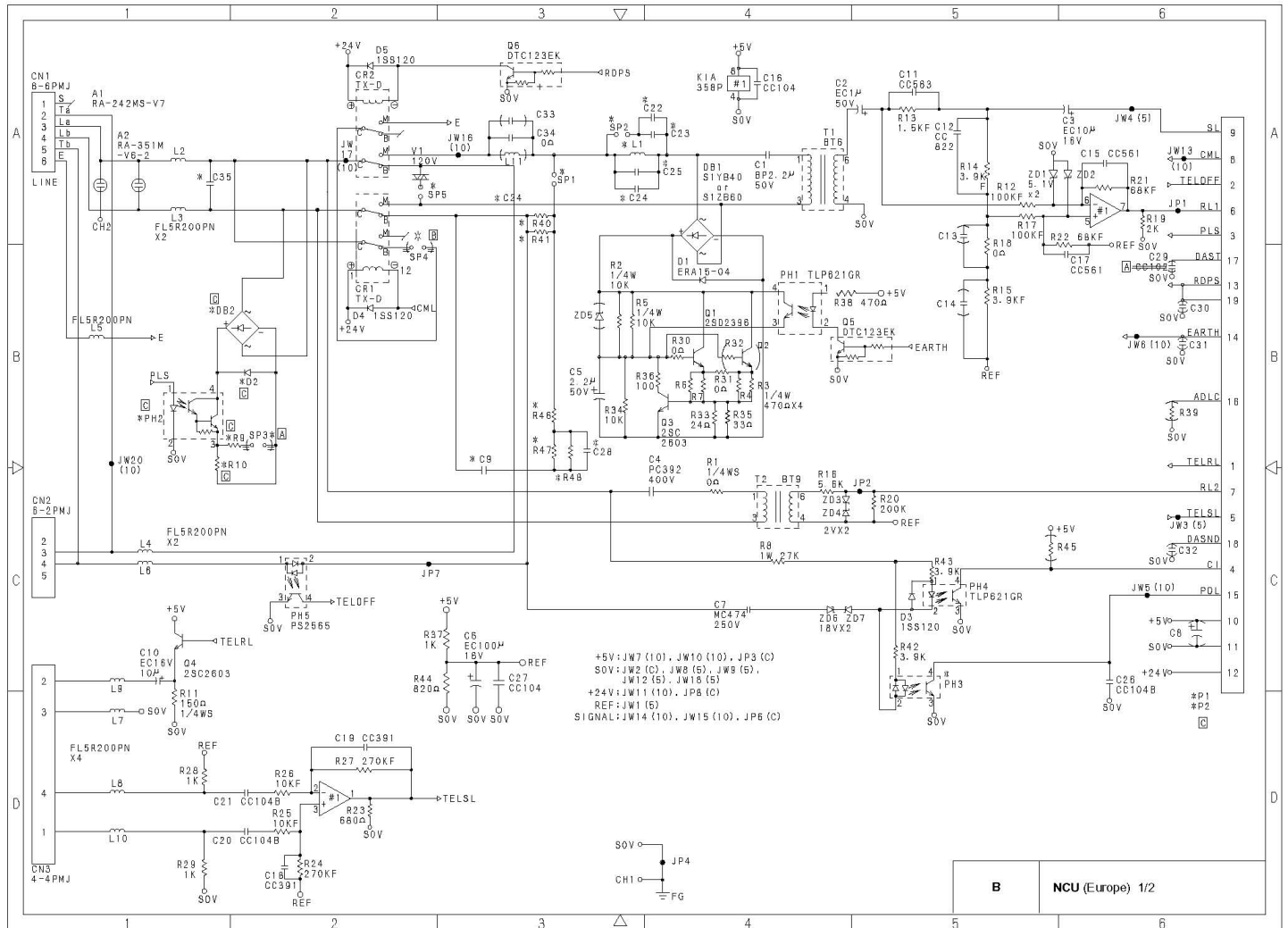

B NCU (Europe) 1/2

ITEM																
03	53	10	60	33	40	04	05	13	07	15	34	45	26	09		
L1	UG8884-000 Coil BRL-0033P					5mm Jumper	5mm Jumper	5mm Jumper					5mm Jumper			
PH3	Not Assy					UG6797-000 Photo TLP620GR	UG6797-000 Photo TLP620GR	Not Assy					UG6797-000 Photo TLP620GR			
PH2	643949-000 Photo TLP627		Not Assy		643949-000 Photo TLP627	UG6702-000 Photo PS2533-1	UG6702-000 Photo PS2533-1	UG6702-000 Photo PS2533-1		643949-000 Photo TLP627		UG6702-000 Photo PS2533-1				
V1	U84397-000 Var ENC121D07A					Not Assy	Not Assy	U84397-000 Var ENC121D07A					U84397-000 Var ENC121D07A			
C9	Not Assy					Y51053-060 PolyC250B105	UG0085-000 PolyC250B474	Not Assy					Not Assy			
C22	Y88270-010 CeraC50C822B					Not Assy	Not Assy	Not Assy					Not Assy			
C23, C24	UG6927-000 CeraC50C153BJ					Not Assy	Not Assy	Not Assy					Not Assy			
C35	Not Assy					UG3704-000 CeraC250B332KH	Not Assy	Not Assy					Not Assy			
R46	Not Assy					094821-120 GR-C110J821	U83013-000 Chip Jumper 2125	Not Assy					Not Assy			
R47, R48	Not Assy					094202-120 GR-C110J202	094242-120 GR-C110J242	Not Assy					Not Assy			
C28	Not Assy					Y81540-011 CeraC50C154B	Not Assy	Not Assy					Not Assy			
R40, R41	Not Assy					Not Assy	Not Assy	Not Assy					094204-120 GR-C110J204			
P1	UG3574000 CN6033B-18Z		U41750-000 CN812B-PHK		UG3574000 CN6033B-18Z	UG3574000 CN6033B-18Z	UG3574000 CN6033B-18Z		U41750-000 CN812B-PHK		UG3574000 CN6033B-18Z					
P2	Not Assy					U84246-000 CN86B-PH-K	Not Assy	Not Assy					U84246-000 CN86B-PH-K			
DB2	UG3118-000 S1BR31Z860		Not Assy		UG3118-000 S1BR31Z860	UG3118-000 S1BR31Z860	UG3118-000 S1BR31Z860					UG3118-000 S1BR31Z860				
D2	UG0690-000 SIDERA15-04		Not Assy		UG0690-000 SIDERA15-04	UG0690-000 SIDERA15-04	UG0690-000 SIDERA15-04					UG0690-000 SIDERA15-04				
R10	Y03900-614 GR-B2YJ391		Not Assy		Y03900-614 GR-B2YJ391	Y03900-614 GR-B2YJ391	Y03900-614 GR-B2YJ391					Y03900-614 GR-B2YJ391				
R9	Y01300-614 GR-B2YJ131		Not Assy		Y01300-614 GR-B2YJ131	Y01300-614 GR-B2YJ131	Y01300-614 GR-B2YJ131					Y01300-614 GR-B2YJ131				
SP1	Not Assy					Assy	Assy					Not Assy				
SP2	Not Assy		Assy		Not Assy	Assy	Not Assy		Not Assy		Not Assy					
SP5	Assy					Not Assy		Not Assy			Assy					
SP3	Assy					Not Assy		Not Assy		Not Assy		Assy				
SP4	Not Assy		Assy		Not Assy		Not Assy			Not Assy		Assy				

Cera C: Ceramic capacitor
 CN: Connector
 Photo: Photo diode
 Poly C: Metallized polyester capacitor
 Var: Varistor

B

NCU (Europe) 2/2

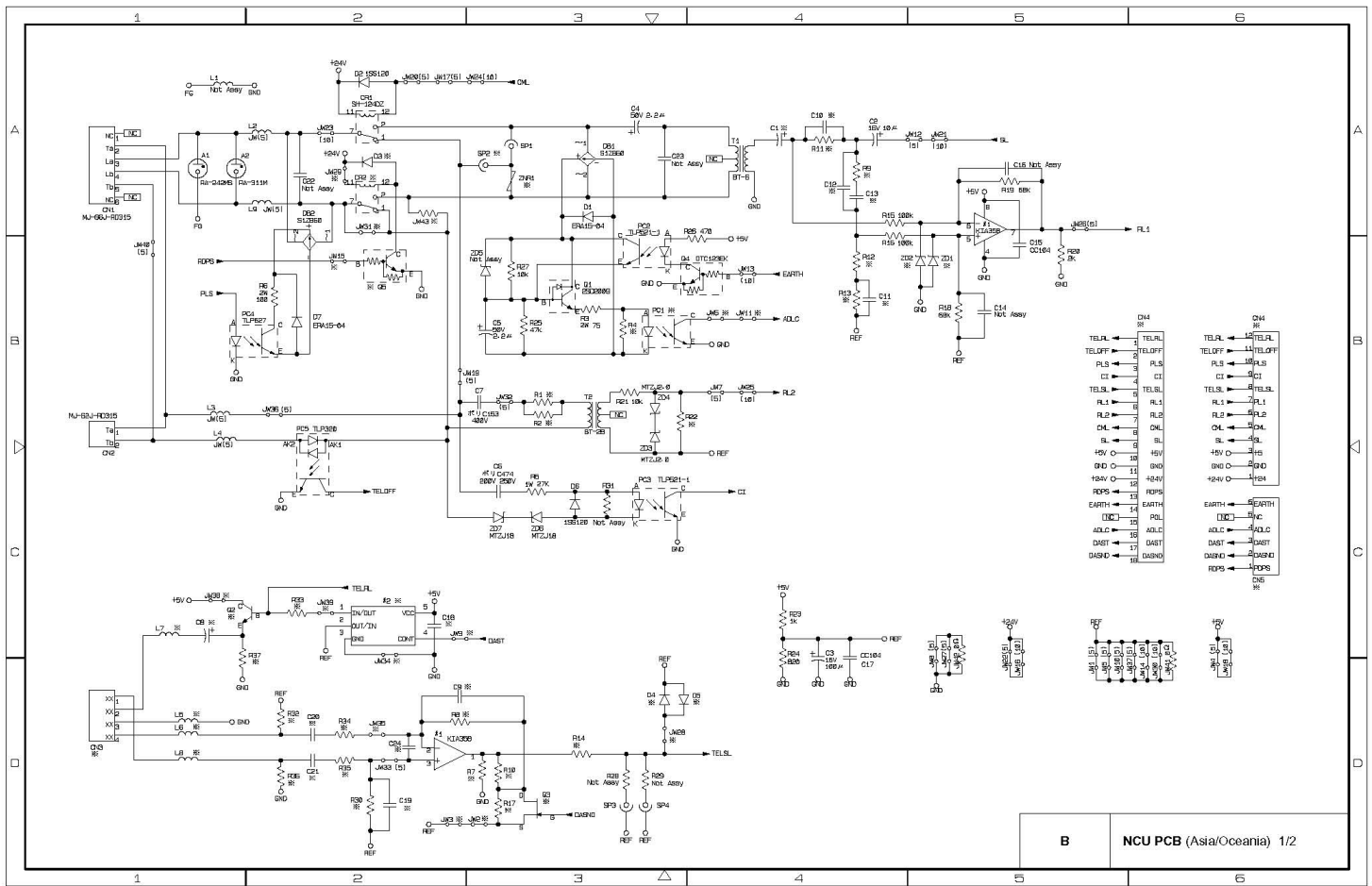

ASSY	NCU B53K479 ASSY OCE	NCU B53K479 ASSY ASA
ADRS.	NAME	NAME
ZNR1	ENC121D07A	Not Assy
SP2	1/16W 0	Not Assy
CR2	SH-124DZ	Not Assy
Q5	DTC123EK	Not Assy
D3	1SS120	Not Assy
JW15	JW(10)	Not Assy
JW29	JW (5)	Not Assy
JW31	Not Assy	JW (5)
JW43	Not Assy	1/16W 0
PC1	Not Assy	TLP521-1G
R4	JW (5)	1/4W 20
JW6;JW11	Not Assy	JW (5)
ZD1;ZD2	Not Assy	MTJ5.1B
R1	Not Assy	1/4W 22K
R2	JW (5)	1/4W 22K
R9	1/16W 1% 2.7K	1/16W 1% 4.7K
R11	1/16W 1% 1.10K	1/16W 1% 910
R12	CERAMIC 16C224B	1/16W 1% 2K
R13	1/16W 1% 3.9K	1/16W 1% 9.1K
R22	1/16W 20K	Not Assy
C1	ALUM-ELEC 50B10-1	ALUM-ELEC 16B100
C10	CERAMIC 50C563B	Not Assy
C11	Not Assy	CERAMIC 50C103B
C12	CERAMIC 50C562B	Not Assy
C13	RESISTOR 0	CERAMIC 16C224B
CN3	MODULAR 4-4P	MODULAR 4-4P
CN5	B6B-PH	B6B-PH
CN4	B12B-PH	B12B-PH
Q2	2SC5395	2SC5395
R7	1/16W 680	1/16W 680
R8;R30	1/16W 1% 270K	1/16W 1% 100K
R14	1/16W 1% 1.6K	1/16W 1% 1K
R32;R36	1/16W 1K	1/16W 1K
R34;R35	1/16W 1% 13K	1/16W 1% 20K
R37	1/16W 150	1/16W 150
C8	ALUM-ELEC 16B100	ALUM-ELEC 16B100
C9;C19	CERAMIC 50C391B	CERAMIC 50C821B
C20;C21	CERAMIC 25C104B	CERAMIC 25C104B
C24	CERAMIC 50C101B	CERAMIC 50C101B
JW35;JW38;L5;L6;L7;L8	JW (5)	JW (5)
D4;D5	1SS120	Not Assy
JW28	JW (5)	Not Assy
#2	Not Assy	TC7S66F
R33	Not Assy	1/16 1% 1.3K
C18	Not Assy	CERAMIC 25C104
JW9;JW34;JW39	Not Assy	JW (5)
Q3	Not Assy	2SK208
R10	1/16W 0	1/16W 1% 1K
R17	Not Assy	1/16W 1% 680
JW2;JW3	Not Assy	JW (5)

B

NCU PCB (Asia/Oceania) 2/2

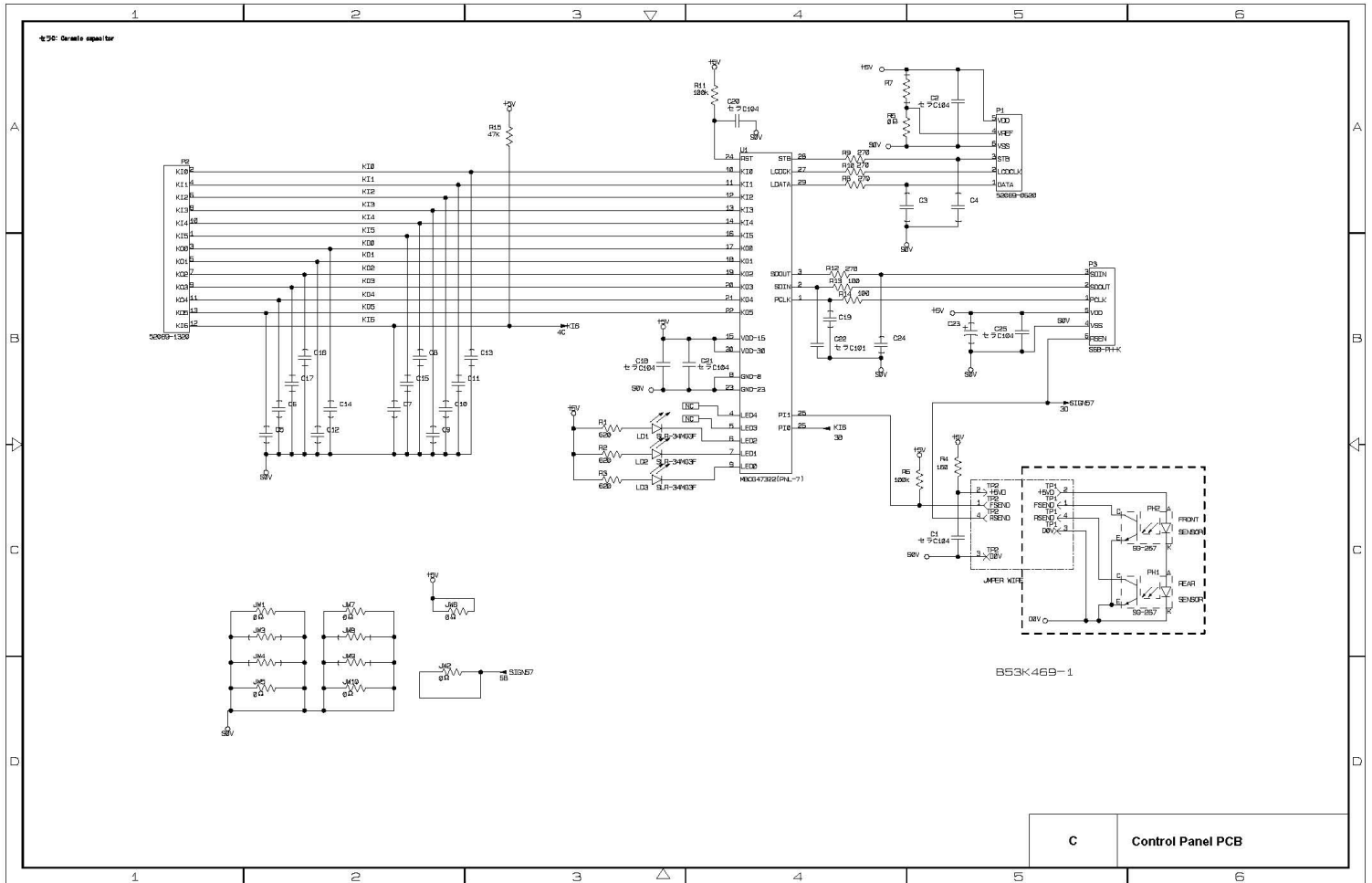

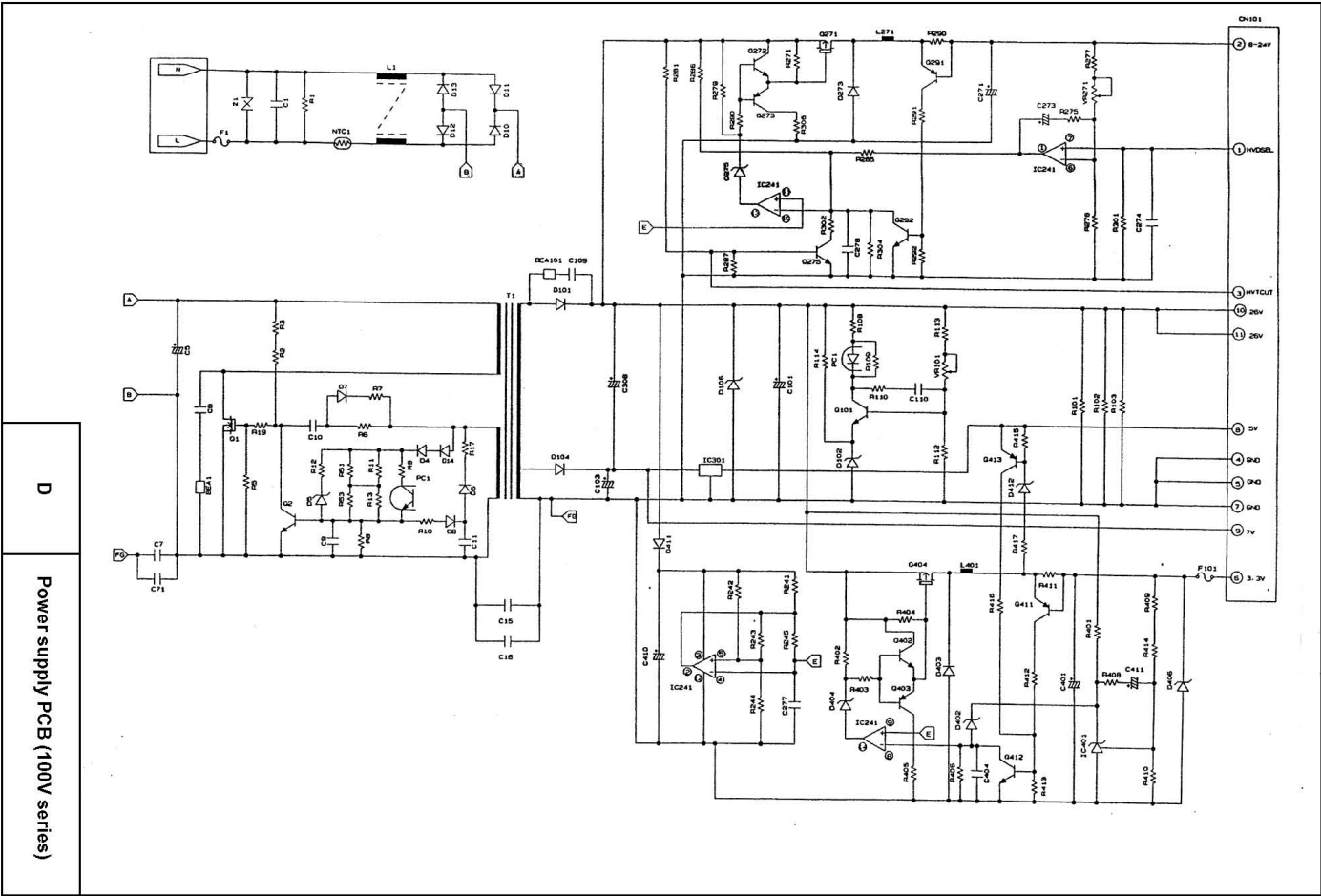

D

Power supply PCB (100V series)

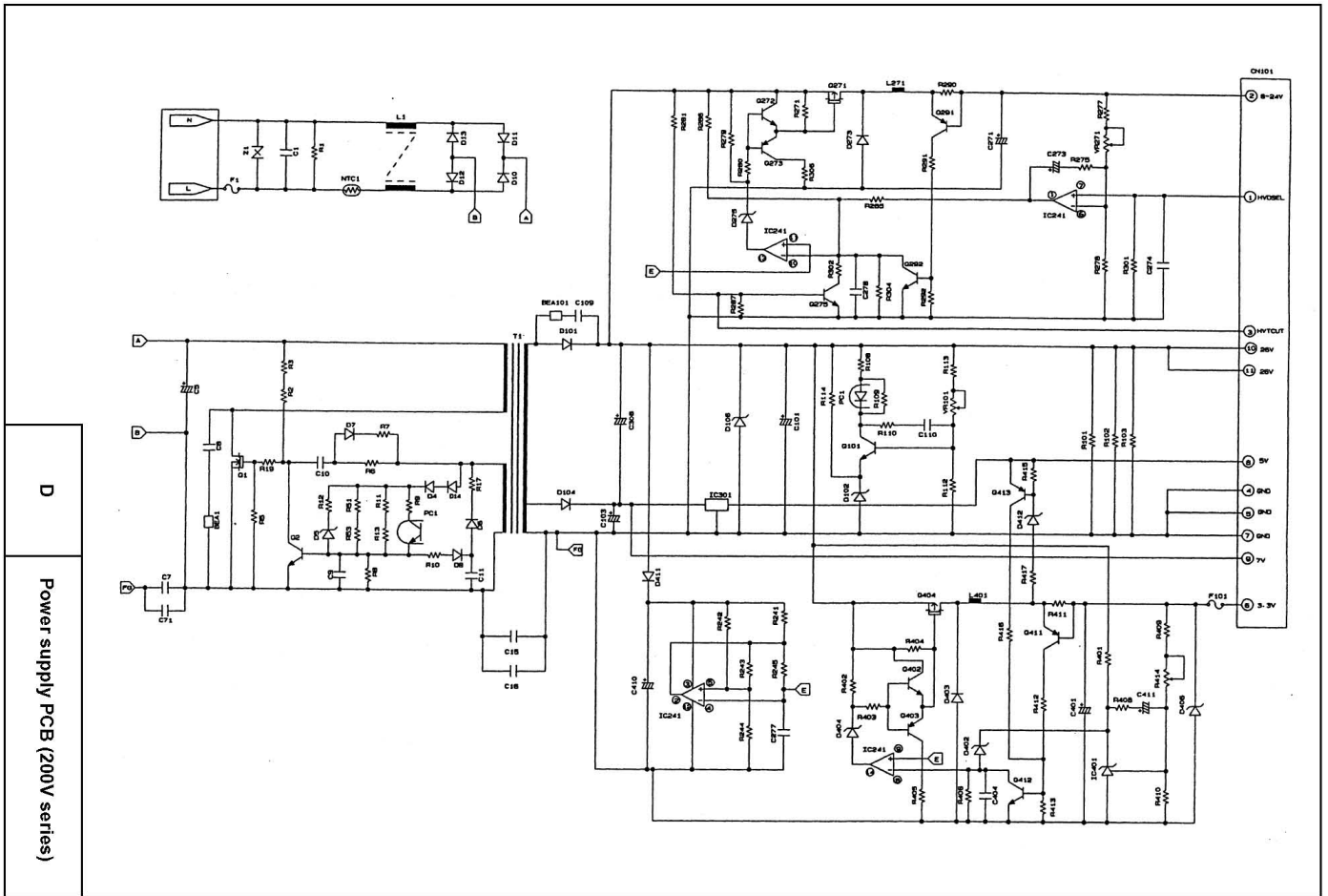

D

Power supply PCB (200V series)

