

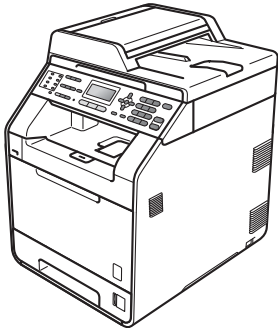





Before using this machine for the first time, read this Quick Setup Guide to setup and install your machine. To view the Quick Setup Guide in other languages, please visit <http://solutions.brother.com/>.

<b>⚠ WARNING</b>	<b>WARNING</b> indicates a potentially hazardous situation which, if not avoided, could result in death or serious injuries.
<b>⚠ CAUTION</b>	<b>CAUTION</b> indicates a potentially hazardous situation which, if not avoided, may result in minor or moderate injuries.

## 1 Unpack the machine and check the components

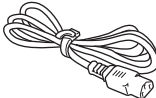
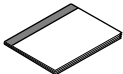
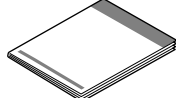
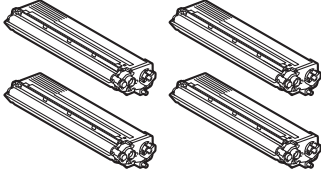
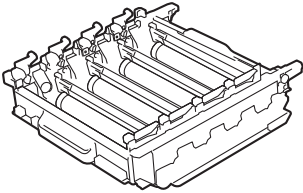
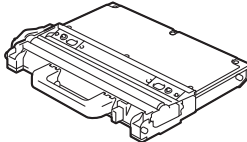
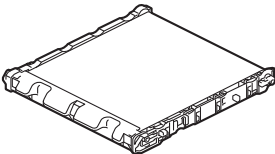
	 <b>Installation CD-ROM, Documentation CD-ROM</b>	 <b>Accessory Order Form</b>	 <b>Product Registration Sheet (USA only)</b>
	 <b>AC Power Cord</b>	 <b>Basic User's Guide</b>	 <b>Quick Setup Guide</b>
 <b>Starter Toner Cartridges (pre-installed) (Black, Cyan, Magenta and Yellow)</b>	 <b>Drum Unit (pre-installed)</b>	 <b>Waste Toner Box (pre-installed)</b>	 <b>Belt Unit (pre-installed)</b>
		 <b>Telephone Line Cord</b>	 <b>Safety and Legal Booklet</b>

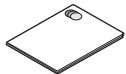
## ⚠ WARNING

- Plastic bags are used in the packaging of your machine. Plastic bags are not toys. To avoid danger of suffocation, please keep these bags away from babies and children and dispose of them properly.
- This machine is heavy and weighs approximately 58.4 lb. (26.5 kg). To prevent possible injuries at least two people should lift the machine. Be careful not to pinch your fingers when you put the machine down.
- If you use a Lower Tray, carry it separately from your machine.

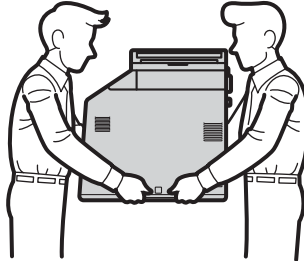

### Note

- Keep a minimum gap around the machine as shown in the illustration.

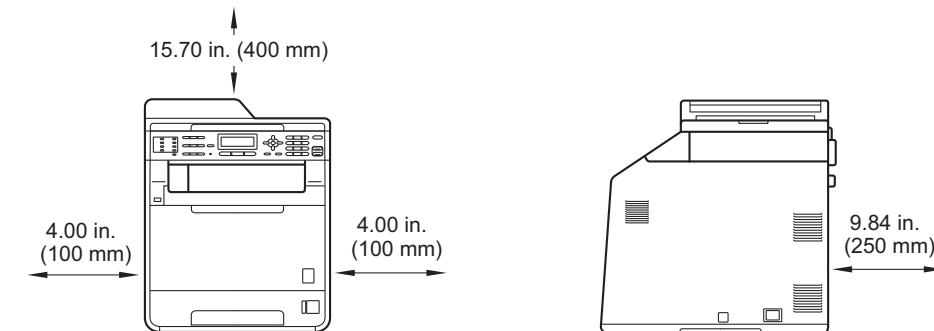

- The components included in the box may differ depending on your country.
- We recommend that you save the original packaging.
- If for any reason you must ship your machine, carefully repack the machine in the original packaging to avoid any damage during transit. The machine should be adequately insured with the carrier. For how to repack the machine, see *Packing and shipping the machine* in the *Advanced User's Guide*.
- The interface cable is not a standard accessory. Buy the appropriate interface cable for the interface you want to use (USB or Network).

#### **USB cable**

- It is recommended to use a USB 2.0 cable (Type A/B) that is no longer than 6 feet (2 meters).
- DO NOT connect the interface cable at this time. Connecting the interface cable is done during MFL-Pro installation process.

#### **Network cable**

Use a straight-through Category5 (or greater) twisted-pair cable for 10BASE-T or 100BASE-TX Fast Ethernet Network.

## 2 Remove the packing material from the machine

### ! IMPORTANT

DO NOT connect the AC power cord yet.

**a** Remove the packing tape from the outside of the machine.

**b** Open the MP tray ①, and remove the plastic sheet ② from the MP tray support, then close the MP tray.

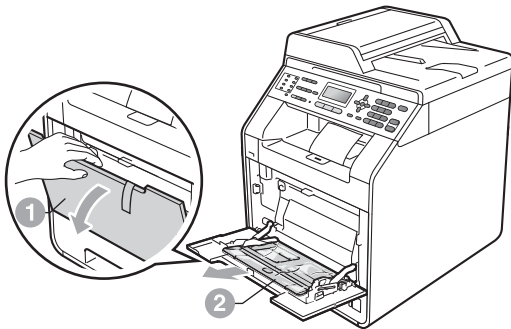

**c** Press the front cover release button and open the front cover. Remove the silica gel pack ①.

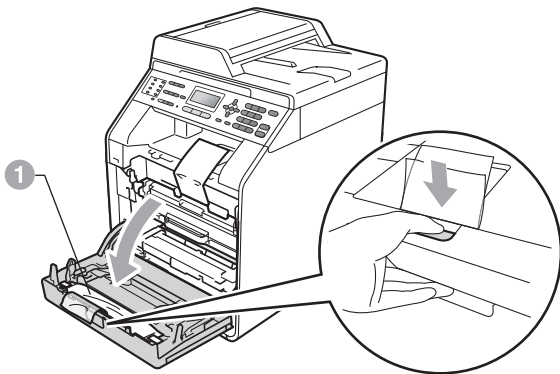

### ! CAUTION

DO NOT eat Silica Pack. Discard immediately.

**d** Hold the green handle of the drum unit ① and pull it out until it stops.

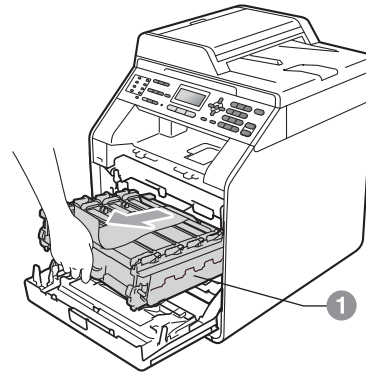

**e** Gently pull the orange packing material towards the front of the machine to remove it.

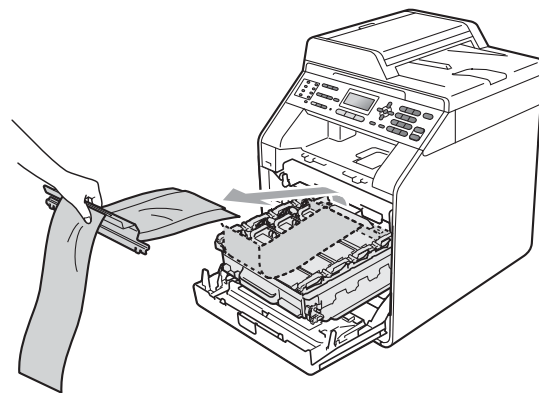

**f** Remove the 4 orange packing pieces.

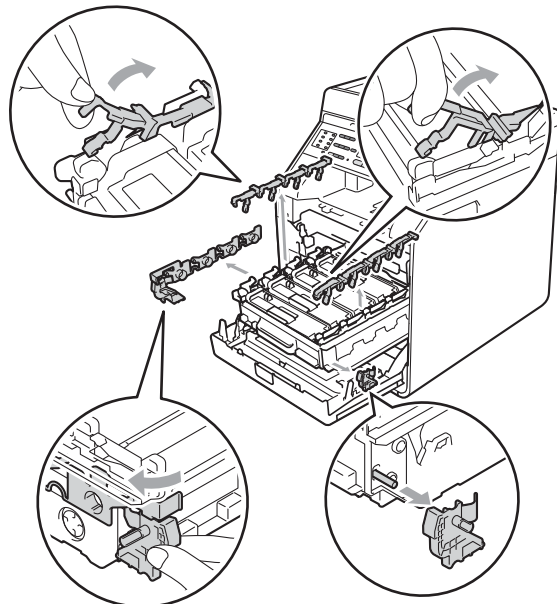

**g** Push the drum unit firmly back into the machine.

**h** Close the front cover of the machine.

# 3

## Load paper in the paper tray

- a** Pull the paper tray completely out of the machine.

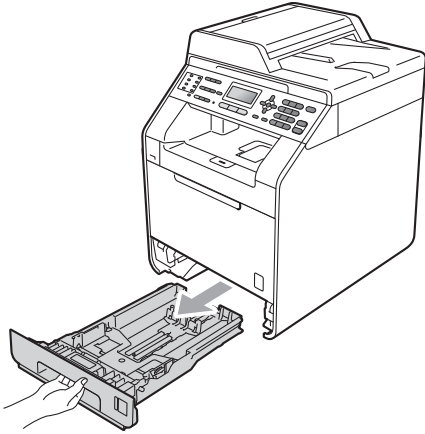

- b** While pressing the green paper-guide release lever ①, slide the paper guides to fit the paper size you are loading in the tray. Make sure that the guides are firmly in the slots.

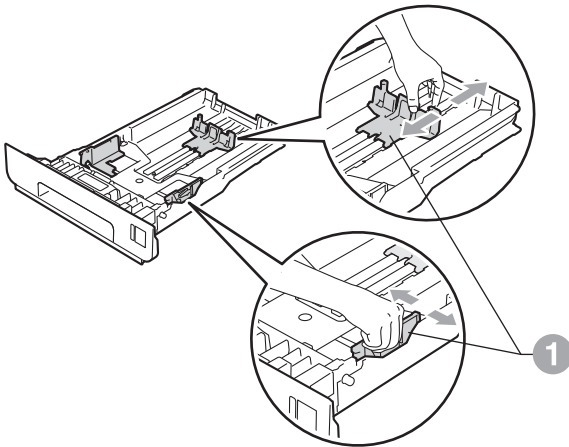

- c** Fan the stack of paper well to avoid paper jams and misfeeds.

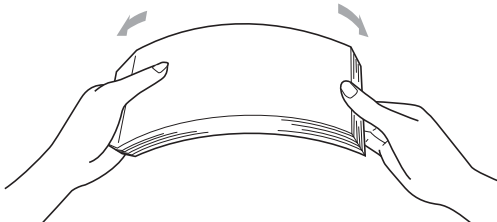

## d

Put paper in the tray and make sure:

- The paper is below the maximum paper mark (▼▼▼) ①.
- Over filling the paper tray will cause paper jams.
- The side to be printed on must be face down.
- The paper guides touch the sides of the paper so it will feed properly.

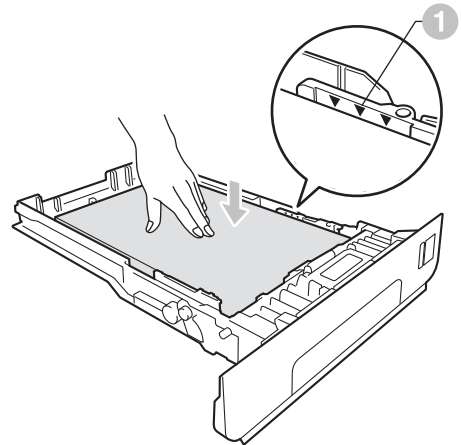

## e

Put the paper tray firmly back in the machine. Make sure that it is completely inserted into the machine.

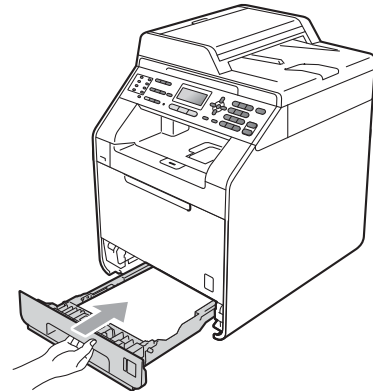

For more information about recommended paper, see *Recommended paper and print media* in the *Basic User's Guide*.

# 4

## Connect the power cord and telephone line

### ! IMPORTANT

DO NOT connect the interface cable yet.



- a Connect the AC power cord to the machine, and then plug it into an AC power outlet.
- b Remove the label covering the machine's power switch, and then switch the machine on.

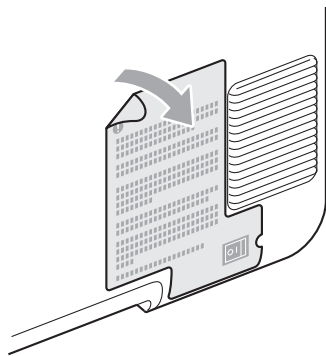

- c Connect the telephone line cord. Connect one end of the telephone line cord to the jack on the machine marked **LINE** and the other end to a modular wall jack.

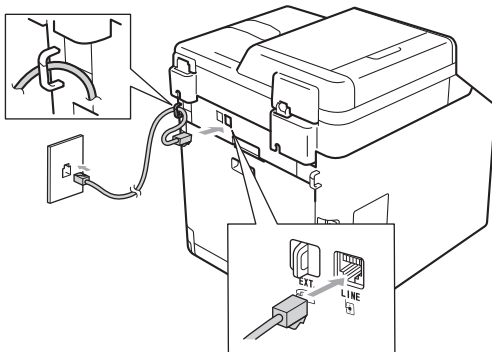

### ! IMPORTANT

The telephone line cord **MUST** be connected to the jack on the machine marked **LINE**.

### ! WARNING

The machine must be grounded using a 3-prong plug.

Since the machine is grounded through the power outlet, you can protect yourself from potentially hazardous electrical conditions on the telephone network by keeping the power cord connected to your machine when you connect it to a telephone line. Similarly, you can protect yourself when you want to move your machine by disconnecting the telephone line first and then the power cord.

### Note

If you are sharing one telephone line with an external telephone, connect it as shown below. Before you connect the external telephone, remove the protective cap 1 from the **EXT.** jack on the machine.

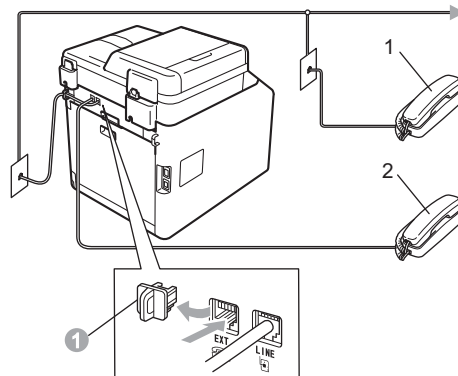



- 1 Extension telephone
- 2 External telephone

 **Note**

If you are sharing one telephone line with an external telephone answering machine, connect it as shown below.

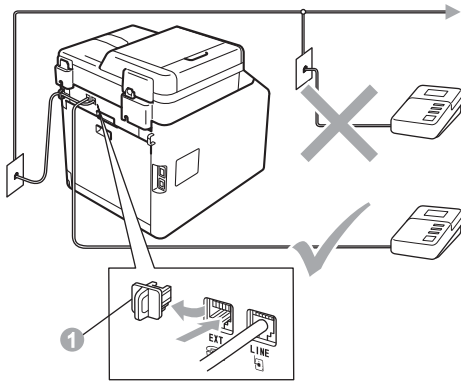
Before you connect the external telephone answering machine, remove the protective cap ① from the **EXT.** jack on the machine.



 Set the receive mode to **External TAD** if you have an external answering machine. See *Choose the correct Receive Mode* on page 7. For additional details, see *Connecting an external TAD (telephone answering device)* in the *Basic User's Guide*.

## 5 Choose your language (if needed)

- a** Press **Menu, 0, 0**.
- b** Press **▲** or **▼** to choose your language.  
Press **OK**.
- c** Press **Stop/Exit**.

# 6

## Choose the correct Receive Mode

The correct Receive Mode is determined by the external devices and telephone subscriber services (Voice Mail, Distinctive Ring, etc.) you have (or will be using) on the same line as the Brother machine.

### Will you be using a Distinctive Ring number for receiving faxes?

Brother uses the term “Distinctive Ring” but telephone companies may have other names for this service such as Custom Ringing, RingMaster, Personalized Ring, Teen Ring, Ident-A-Call, and Smart Ring. See *Distinctive Ring* in the *Basic User's Guide* for instruction on setting up your machine using this feature.

### Will you be using Voice Mail on the same telephone line as your Brother machine?

If you have Voice Mail on the same telephone line as your Brother machine, there is a strong possibility that Voice Mail and the Brother machine will conflict with each other when receiving incoming calls. See *Voice Mail* in the *Basic User's Guide* for instructions on setting up your machine using this service.

### Will you be using a Telephone Answering Device on the same telephone line as your Brother machine?

Your external telephone answering device (TAD) will automatically answer every call. Voice messages are stored on the external TAD and fax messages are printed. Choose `External TAD` as your receive mode. See the instructions below.

### Will you be using your Brother machine on a dedicated fax line?

Your machine automatically answers every call as a fax. Choose `Fax Only` as your receive mode. See the instructions below.

### Will you be using your Brother machine on the same line as your telephone?

#### Do you want to receive voice calls and faxes automatically?

The `Fax/Tel` receive mode is used when sharing the Brother machine and your telephone on the same line. Choose `Fax/Tel` as your receive mode. See the instructions below.

**Important Note:** You cannot receive voice messages on either Voice Mail or an answering machine when choosing the `Fax/Tel` mode.

#### Do you expect to receive very few faxes?

Choose `Manual` as your receive mode. You control the telephone line and must answer every call yourself. See the instructions below.

 For details, see *Using receive modes* in the *Basic User's Guide*.

- a** Press **Menu**, **0**, **1**.
- b** Press **▲** or **▼** to choose the receive mode.  
Press **OK**.
- c** Press **Stop/Exit**.

## 7 Set the LCD contrast (if needed)

If you are having difficulty reading the LCD, try changing the contrast setting.

- a** Press **Menu**, **1**, **6**.
- b** Press **▶** to increase the contrast.  
—OR—  
Press **◀** to decrease the contrast.  
Press **OK**.
- c** Press **Stop/Exit**.

## 8 Set the date and time

The machine displays the time, and if you set up the station ID the date and time will be added to each fax you send.

- a** Press **Menu**, **0**, **2**, **1**.
- b** Enter the last two digits of the year on the dial pad, and then press **OK**.

02.Date&Time
Year:2011
Enter & OK Key

(e.g. Enter **1**, **1** for 2011.)

- c** Enter the two digits for the month on the dial pad, and then press **OK**.

02.Date&Time
XX/XX/2011
Month:03
Enter & OK Key

(e.g. Enter **0**, **3** for March.)

- d** Enter the two digits for the day on the dial pad, and then press **OK**.

02.Date&Time
03/XX/2011
Day:25
Enter & OK Key

(e.g. Enter **2**, **5** for 25th.)

- e** Enter the time in 24-hour format on the dial pad, and then press **OK**.

02.Date&Time
03/25/2011
Time:15:25
Enter & OK Key

(e.g. Enter **1**, **5**, **2**, **5** for 3:25 P.M.)

- f** Press **Stop/Exit**.



# 9

## Set your Station ID

The machine displays the date and time, and if you set up the Station ID, it will add it to each fax you send.

**a** Press **Menu**, **0**, **3**.

**b** Enter your fax number (up to 20 digits) on the dial pad, and then press **OK**.

```

03.Station ID
Fax: _
Enter & OK Key
    
```

**c** Enter your telephone number (up to 20 digits) on the dial pad, and then press **OK**. (If your telephone number and fax number are the same, enter the same number again.)

```

03.Station ID
Fax:XXXXXXXXXXXX
Tel: _
Enter & OK Key
    
```

**d** Use the dial pad to enter your name (up to 20 characters), and then press **OK**.

```

03.Station ID
Fax:XXXXXXXXXXXX
Tel:XXXXXXXXXXXX
Name: _
Enter & OK Key
    
```

### Note

- See the following chart for entering your name.
- If you need to enter a character that is on the same key as the last character, press **▶** to move the cursor to the right.
- If you entered a letter incorrectly and want to change it, press **◀** or **▶** to move the cursor to the incorrect character, press **Clear**.

Press key	One time	Two times	Three times	Four times	Five times
2	A	B	C	2	A
3	D	E	F	3	D
4	G	H	I	4	G
5	J	K	L	5	J
6	M	N	O	6	M
7	P	Q	R	S	7
8	T	U	V	8	T
9	W	X	Y	Z	9

 For more details, see *Entering text* in the *Basic User's Guide*.

**e** Press **Stop/Exit**.

### Note

If you make a mistake and want to start again, press **Stop/Exit** and go back to step **a**.

(USA only) The Telephone Consumer Protection Act of 1991 makes it unlawful for any person to use a computer or electronic device to send any message via a telephone fax machine unless such messages clearly contain, in a margin at the top or bottom of each transmitted page, or on the first page of the transmission, the date and time it is sent and an identification of the business or other entity or other individual sending the message and the telephone number of the sending machines or such business, other entity or individual. To program this information into your machine, see *Set the date and time* on page 8 and *Set your Station ID* on page 9.

## 10 Fax Transmission Report

Your Brother machine is equipped with a Transmission Verification Report that can be used as confirmation that you sent a fax. This report lists the name or fax number of the receiving party, the date, time, and duration of the transmission, the number of pages transmitted, and whether or not the transmission was successful. If you want to use the Fax Transmission Report feature see *Printing reports* in the *Advanced User's Guide*.

## 11 Set tone or pulse dialing mode (Canada only)

Your machine comes set for Tone dialing service. If you have Pulse dialing service (rotary), you need to change the dialing mode.

- a** Press **Menu**, **0**, **4**.
- b** Press **▲** or **▼** to choose **Pulse** (or **Tone**). Press **OK**.
- c** Press **Stop/Exit**.

## 12 Set the telephone line compatibility

If you are connecting the machine to a VoIP service (over the Internet) you need to change the compatibility setting.



### Note

If you are using an analog telephone line you can skip this step.

- a** Press **Menu**, **2**, **0**, **1**.
- b** Press **▲** or **▼** to choose **Basic** (for VoIP). Press **OK**.
- c** Press **Stop/Exit**.

## 13 Dial Prefix

The dial prefix setting will automatically dial a predefined number before every fax number you dial. For example: If your phone system requires a 9 to dial an outside number this setting will automatically dial 9 for every fax you send.

- a** Press **Menu, 0, 5** (for Canada, press **6**).
- b** Enter the prefix number (up to 5 digits) on the dial pad, and then press **OK**.



### Note

- You can use the number 0 to 9, #, \* and !. (Press **Hook** to display "!".)
- You cannot use ! with any other numbers or characters.
- If your telephone system requires a timed break recall (hookflash), press **Hook** to enter the break.
- If the pulse dialing mode is on, # and \* are not available to use. (Canada only)

- c** Press **Stop/Exit**.

## 14 Automatic Daylight Savings Time

You can set the machine to change automatically for daylight savings time. It will reset itself forward one hour in the Spring and backward one hour in the Fall.

- a** Press **Menu, 0, 2, 2**.
- b** Press **▲** or **▼** to choose **On** (or **Off**). Press **OK**.
- c** Press **Stop/Exit**.

## 15 Set the Time Zone

You can set the time zone (not summer time but standard time) on the machine for your location. For example, the time zone for Eastern Time in the USA and Canada is UTC-05:00.

- a** Press **Menu, 0, 2, 3**.
- b** Press **▲** or **▼** to choose the time zone. Press **OK**.
- c** Press **Stop/Exit**.

# 16 Send in the Product Registration and Test Sheet (USA only)

You can also register your product online using the On-Line Registration link from the installation CD-ROM or visit <http://www.brother.com/registration/>.

- a** Fill out the Product Registration and Test Sheet.

- b** Put the sheet face up in the ADF (Automatic Document Feeder) or face down on the scanner glass.

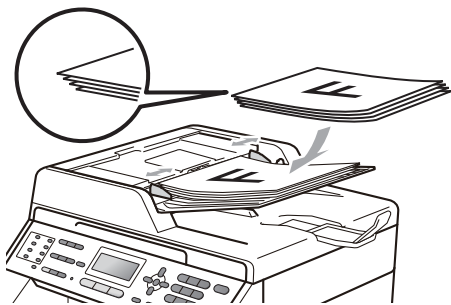

- c** Make sure  (FAX) is illuminated in Blue.
- d** Enter the toll-free fax number: 1-877-268-9575.
- e** Press **Black Start** or **Color Start**.



### Note

You will receive a confirmation fax of your Product Registration.

# 17 Choose your connection type

These installation instructions are for Windows® 2000 Professional, Windows® XP Home/Windows® XP Professional, Windows® XP Professional x64 Edition, Windows Vista®, Windows® 7, and Mac OSX (versions 10.4.11, 10.5.x and 10.6.x).

## Note

For Windows Server® 2003/2003 x64 Edition/2008/2008 R2, visit your model page at <http://solutions.brother.com/>.

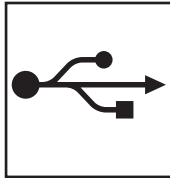
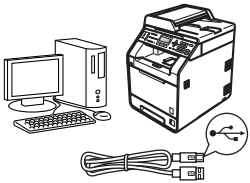

## For USB Interface Users

Windows®, go to page 14  
Macintosh, go to page 16

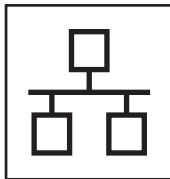
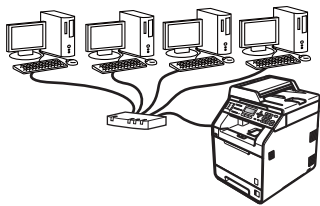

## For Wired Network

Windows®, go to page 18  
Macintosh, go to page 21

## Note

You can download the latest drivers and utilities for your machine from the Brother Solutions Center at <http://solutions.brother.com/>.

USB	Windows®
	Macintosh
Wired Network	Windows®
	Macintosh



## For USB Interface Users (Windows® 2000 Professional/XP/XP Professional x64 Edition/ Windows Vista®/Windows® 7)

### 18 Before you install

- a** Make sure that your computer is ON and you are logged on with Administrator rights.

#### ! IMPORTANT

- If there are any programs running, close them.
- The screens may differ depending on your operating system.

#### Note

The installation CD-ROM includes ScanSoft™ PaperPort™ 12SE. This software supports Windows® XP (SP3 or greater), XP Professional x64 Edition (SP3 or greater), Windows Vista® (SP2 or greater) and Windows® 7. Update to the latest Windows® Service Pack before installing MFL-Pro Suite. For Windows® 2000 (SP4 or greater) users, when the ScanSoft™ PaperPort™ 11SE download screen appears during the installation of MFL-Pro Suite, follow the on-screen instructions.

- b** Turn off the machine and make sure the USB interface cable is **NOT** connected to the machine. If you have already connected the cable, disconnect it.

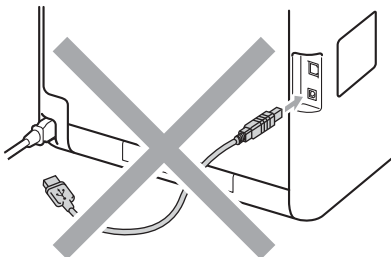

### 19 Install MFL-Pro Suite

- a** Put the installation CD-ROM into your CD-ROM drive. If the model name screen appears, choose your machine. If the language screen appears, choose your language.

#### Note

If the Brother screen does not appear automatically, go to **My Computer (Computer)**, double-click the CD-ROM icon, and then double-click **start.exe**.

- b** Click **Initial Installation** and then **Install MFL-Pro Suite**.



- c** Click **Yes** if you accept the license agreements.

#### Note

- If the installation does not continue automatically, open the top menu again by ejecting and then reinserting the CD-ROM or double-click the **start.exe** program from the root folder, and continue from step **b** to install MFL-Pro Suite.
- For Windows Vista® and Windows® 7 users, when the **User Account Control** screen appears, click **Allow** or **Yes**.
- If you want to install the PS driver (BR-Script3 printer driver), choose **Custom Install** and then follow the on-screen instructions.

- d** Follow the on-screen instructions until this screen appears.

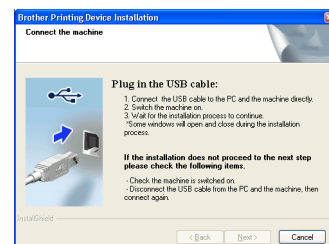



- e Connect the USB cable to the USB connector marked with the  symbol on your machine and then connect the cable to your computer.

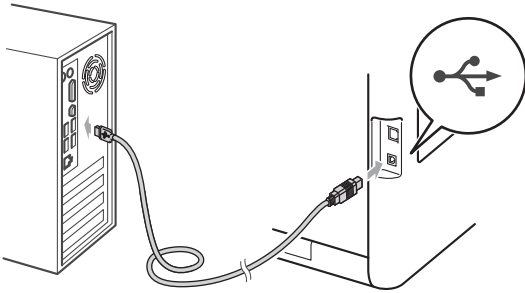

- f Turn the machine on, and follow the on-screen instructions to complete setup.

## ! IMPORTANT

**DO NOT cancel any of the screens during the installation. It may take a few seconds for all screens to appear.**



### Note

- For Windows Vista® and Windows® 7 users, when the **Windows Security** screen appears, click the check box and click **Install** to complete the installation correctly.
- If an error message appears during the software installation, run the **Installation Diagnostics** located in **start/All Programs/Brother/MFC-XXXX** (where MFC-XXXX is your model name).

## Finish

**The installation is now complete.**



### Note

- Depending on your security settings, a Windows Security or antivirus software window may appear when using the machine or its software. Please allow or permit the window to continue.
- **XML Paper Specification Printer Driver**  
The XML Paper Specification Printer Driver is the most suitable driver when printing from the applications that use the XML Paper Specification documents. Please download the latest driver by accessing the Brother Solutions Center at <http://solutions.brother.com/>.



## For USB Interface Users (Mac OS X 10.4.11 - 10.6.x)

### 18 Before you install

- a** Make sure your machine is connected to the power and your Macintosh is ON. You must be logged on with Administrator rights.

#### ! IMPORTANT

For Mac OS X 10.4.10 users, upgrade to Mac OS X 10.4.11 - 10.6.x. (For the latest drivers and information on the Mac OS X you are using, visit <http://solutions.brother.com/>.)

#### Note

If you want to setup the PS driver (BR-Script3 printer driver), please go to the Brother Solutions Center at <http://solutions.brother.com/> and click Downloads on your model page and visit FAQ's for setup instructions.

- b** Connect the USB cable to the USB connector marked with the  symbol on your machine and then connect the cable to your Macintosh.

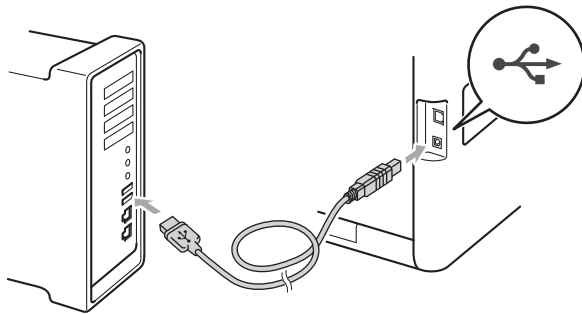

- c** Make sure your machine's power switch is on.

### 19 Install MFL-Pro Suite

- a** Put the installation CD-ROM into your CD-ROM drive.
- b** Double-click the **Start Here OSX** icon. Follow the on-screen instructions.



#### Note

It may take a few minutes for installation to complete.

- c** Follow the on-screen instructions until this screen appears. Choose your machine from the list, and then click **OK**.

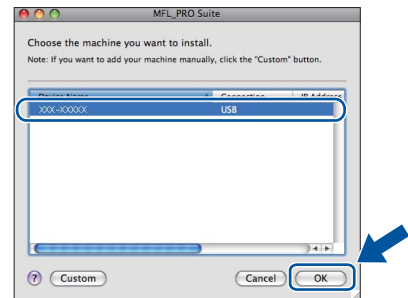

- d** When this screen appears, click **Next**.

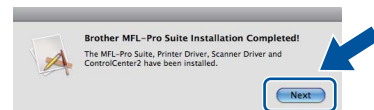

- OK!** The installation of MFL-Pro Suite is now complete. Go to step 20 on page 17.





## 20 Download and install Presto! PageManager

When Presto! PageManager is installed OCR capability is added to Brother ControlCenter2. You can easily scan, share and organize photos and documents using Presto! PageManager.

- a On the **Brother Support** screen, click **Presto! PageManager** and follow the on-screen instructions.

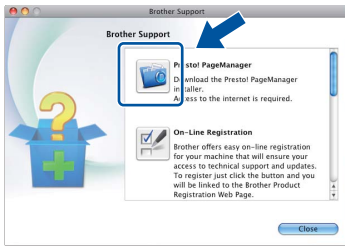

**Finish** The installation is now complete.

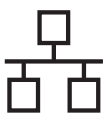

## For Wired Network Interface Users (Windows® 2000 Professional/XP/XP Professional x64 Edition/ Windows Vista®/Windows® 7)

### 18 Before you install

- a** Make sure that your computer is ON and you are logged on with Administrator rights.

#### ! IMPORTANT

- If there are any programs running, close them.
- The screens may differ depending on your operating system.

#### Note

- The installation CD-ROM includes ScanSoft™ PaperPort™ 12SE. This software supports Windows® XP (SP3 or greater), XP Professional x64 Edition (SP3 or greater), Windows Vista® (SP2 or greater) and Windows® 7. Update to the latest Windows® Service Pack before installing MFL-Pro Suite. For Windows® 2000 (SP4 or greater) users, when the ScanSoft™ PaperPort™ 11SE download screen appears during the installation of MFL-Pro Suite, follow the on-screen instructions.
- Disable all personal firewall software (other than Windows® Firewall), anti-spyware or antivirus applications for the duration of the installation.

- b** Remove the protective cap from the LAN connector marked with a  symbol.

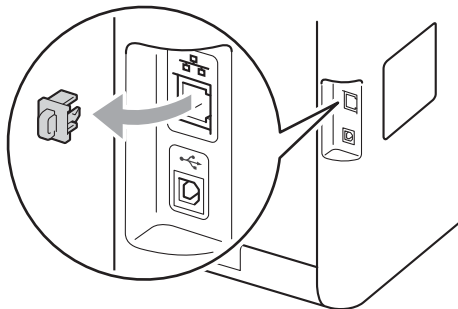

- c** Connect the network interface cable to the LAN connector and then connect it to a free port on your hub.

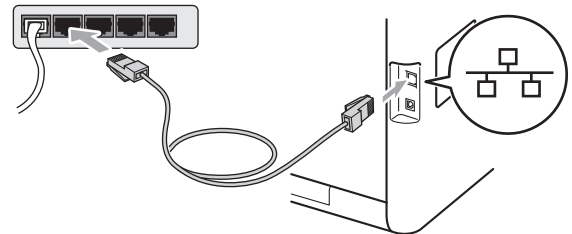

- d** Make sure your machine's power switch is on.

### 19 Install MFL-Pro Suite

- a** Put the installation CD-ROM into your CD-ROM drive. If the model name screen appears, choose your machine. If the language screen appears, choose your language.

#### Note

If the Brother screen does not appear automatically, go to **My Computer (Computer)**, double-click the CD-ROM icon, and then double-click **start.exe**.

- b** Click **Initial Installation** and then **Install MFL-Pro Suite**.



- c** Click **Yes** if you accept the license agreements.

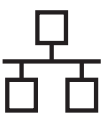

## Note

- If the installation does not continue automatically, open the top menu again by ejecting and then reinserting the CD-ROM or double-click the **start.exe** program from the root folder, and continue from step **b** to install MFL-Pro Suite.
- For Windows Vista® and Windows® 7 users, when the **User Account Control** screen appears, click **Allow** or **Yes**.
- If you want to install the PS driver (BR-Script3 printer driver), choose **Custom Install** and then follow the on-screen instructions.

**d** When the **Firewall/AntiVirus detected** screen appears, choose **Change the Firewall port settings to enable network connection and continue with the installation. (Recommended)** and click **Next**. (Not for Windows® 2000 users)

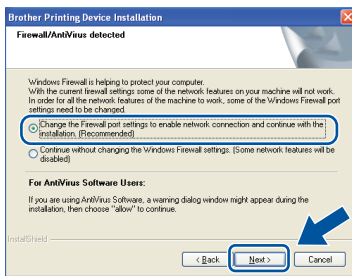

If you are not using the Windows® Firewall, see the user's guide for your software for information on how to add the following network ports.

- For network scanning, add UDP port 54925.
- For network PC-Fax receiving, add UDP port 54926.
- If you still have trouble with your network connection, add UDP port 137.

**e** Follow the on-screen instructions to complete setup.

## ! IMPORTANT

**DO NOT cancel any of the screens during the installation. It may take a few seconds for all screens to appear.**

## Note

- If your machine is not found over the network, confirm your settings by following the on-screen instructions.
- You can find your machine's IP address and the node name by printing out the Network Configuration List. See *Print the Network Configuration List* on page 23.
- For Windows Vista® and Windows® 7 users, when the **Windows Security** screen appears, click the check box and click **Install** to complete the installation correctly.
- If an error message appears during the software installation, run the **Installation Diagnostics** located in **start/All Programs/Brother/MFC-XXXX LAN** (where MFC-XXXX is your model name).

## 20 Install MFL-Pro Suite on additional computers (if needed)

If you want to use your machine with multiple computers on the network, install MFL-Pro Suite on each computer. Go to step **19** on page 18.

## Note

### Network license (Windows®)

This product includes a PC license for up to 5 users. This license supports the installation of the MFL-Pro Suite including ScanSoft™ PaperPort™ 12SE or ScanSoft™ PaperPort™ 11SE on up to 5 PCs on the network. If you want to use more than 5 PCs with ScanSoft™ PaperPort™ 12SE or ScanSoft™ PaperPort™ 11SE installed, please purchase the Brother NL-5 pack which is a multiple PC license agreement pack for up to 5 additional users. To purchase the NL-5 pack, contact your authorized Brother dealer or contact Brother customer service.

# Finish

## The installation is now complete.

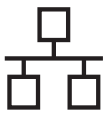

## Note

- If you use a specified IP Address for the machine, you must set the Boot Method to Static by using the control panel. For more information, see *Network menu* in the *Network User's Guide*.
- Depending on your security settings, a Windows Security or antivirus software window may appear when using the machine or its software. Please allow or permit the window to continue.
- **XML Paper Specification Printer Driver**  
The XML Paper Specification Printer Driver is the most suitable driver when printing from the applications that use the XML Paper Specification documents. Please download the latest driver by accessing the Brother Solutions Center at <http://solutions.brother.com/>.

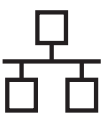

## For Wired Network Interface Users (Mac OS X 10.4.11 - 10.6.x)

### 18 Before you install

- a** Make sure your machine is connected to the power and your Macintosh is ON. You must be logged on with Administrator rights.

**! IMPORTANT**  
For Mac OS X 10.4.10 users, upgrade to Mac OS X 10.4.11 - 10.6.x. (For the latest drivers and information on the Mac OS X you are using, visit <http://solutions.brother.com/>.)

**Note**  
If you want to setup the PS driver (BR-Script3 printer driver), please go to the Brother Solutions Center at <http://solutions.brother.com/> and click Downloads on your model page and visit FAQ's for setup instructions.

- b** Remove the protective cap from the LAN connector marked with a  symbol.

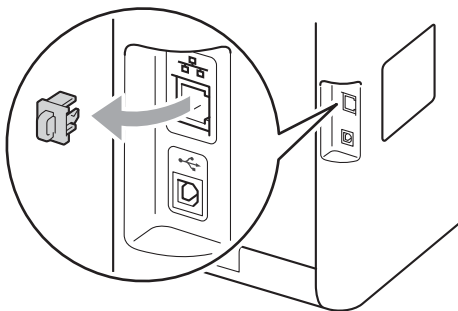

- c** Connect the network interface cable to the LAN connector and then connect it to a free port on your hub.

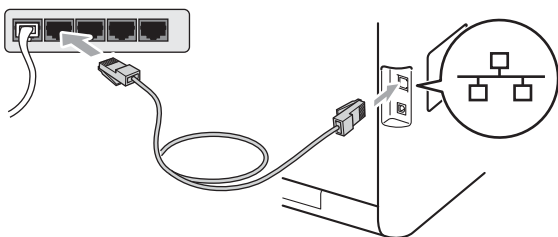

- d** Make sure your machine's power switch is on.

### 19 Install MFL-Pro Suite

- a** Put the installation CD-ROM into your CD-ROM drive.
- b** Double-click the **Start Here OSX** icon. Follow the on-screen instructions.



**Note**  
It may take a few minutes for installation to complete.

- c** Follow the on-screen instructions until this screen appears. Choose your machine from the list, and then click **OK**.

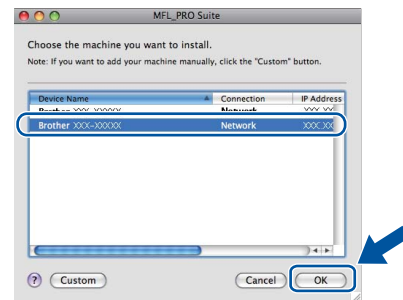

**Note**  
If your machine is not found over the network, confirm your network settings. See *Before you install* on page 21.

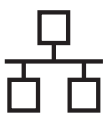

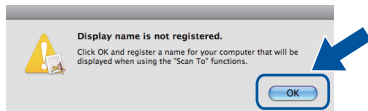

## Note

- You can find your machine's MAC Address (Ethernet Address) and IP Address by printing out the Network Configuration List. See *Print the Network Configuration List* on page 23.
- If this screen appears click **OK**.

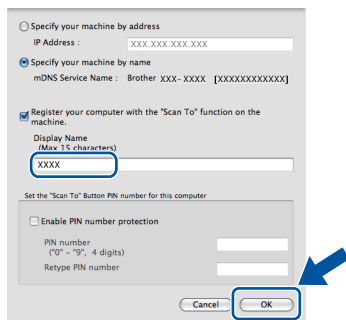

Enter a name for your Macintosh in **Display Name** up to 15 characters long and click **OK**. Go to **d**.



- If you want to use the machine's **SCAN** key to scan over the network, you must check the **Register your computer with the "Scan To" function on the machine box**.
- The name you enter will appear on the machine's LCD when you press  (**SCAN**) and choose a scan option. (For more information, see *Network Scanning* in the *Software User's Guide*.)

**d** When this screen appears, click **Next**.

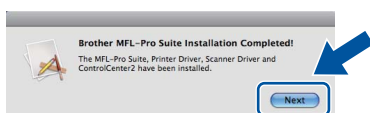

**OK!** The installation of MFL-Pro Suite is now complete. Go to step 20 on page 22.

## 20 Download and install Presto! PageManager

When Presto! PageManager is installed OCR capability is added to Brother ControlCenter2. You can easily scan, share and organize photos and documents using Presto! PageManager.

**a** On the **Brother Support** screen, click **Presto! PageManager** and follow the on-screen instructions.

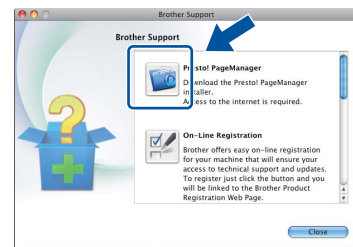

## 21 Install MFL-Pro Suite on additional computers (if needed)

If you want to use your machine with multiple computers on the network, install MFL-Pro Suite on each computer. Go to step 19 on page 21.

# Finish

## The installation is now complete.

## Note

If you use a specified IP Address for the machine, you must set the Boot Method to Static by using the control panel. For more information, see *Network menu* in the *Network User's Guide*.

## Web Based Management (web browser)

The Brother print server is equipped with a web server that allows you to monitor its status or change some of its configuration settings, using HTTP (Hyper Text Transfer Protocol).

### Note

- The default User Name is **'admin'** and the default password is **'access'**. You can use a web browser to change this password.
- We recommend Microsoft® Internet Explorer® 6.0 (or greater) or Firefox 3.0 (or greater) for Windows® and Safari 3.0 (or greater) for Macintosh. Please also make sure that JavaScript and cookies are always enabled in whichever browser you use. To use a web browser, you will need to know the IP address of the print server. The IP address of the print server is listed on the Network Configuration List.

- a Open your browser.
- b Type `http://machine_ip_address/` into your browser (where `machine_ip_address` is the IP address of the printer or the print server name).
  - For example `http://192.168.1.2/`

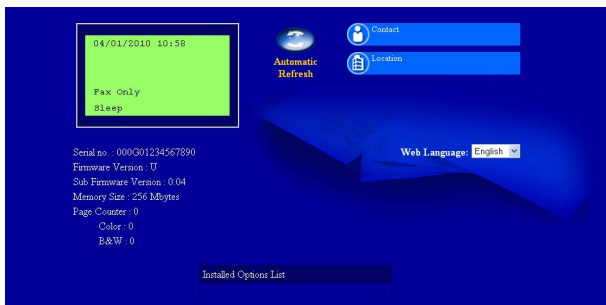

See *Web Based Management* in the *Network User's Guide*.

## Print the Network Configuration List

You can print the Network Configuration List to confirm the current network settings.

- a Turn on the machine and wait until the machine is in the Ready state.
- b Press **Menu, 6, 6**.
- c Press **Black Start** or **Color Start**.  
The machine will print the current network settings.

## Restore the network settings to factory default

To restore all network settings of the internal Print/Scan server to factory default, please follow the steps below.

- a Make sure the machine is not operating, then disconnect all the cables from the machine (except the power cord).
- b Press **Menu, 7, 0**.
- c Press **1** to choose **Reset**.
- d Press **1** to choose **Yes**.  
The machine will restart, re-connect cables once this is complete.

## Color Correction (if needed)

### Color Calibration

The output density for each color may vary depending on the environment the machine is in, such as temperature and humidity. Calibration helps you to improve the color density.

#### Note

- If you print using the Direct Print feature or the BR-Script printer driver, you need to perform the calibration from the control panel. See *Using the control panel* on page 24.
- If you print using the Windows® printer driver, the driver will get the calibration data automatically if both **Use Calibration Data** and **Get Device Data Automatically** are on. See *Advanced tab* in the *Software User's Guide*.
- If you print using the Macintosh printer driver, you need to perform the calibration using **Status Monitor**. After turning **Status Monitor** on, choose **Color Calibration** from **Control** menu. See *Status Monitor* in the *Software User's Guide*.

### Using the control panel

- Press **Menu**, **4**, **6**.
- Press **▲** or **▼** to choose **Calibrate**.  
Press **OK**.
- Press **1** to choose **Yes**.
- Press **Stop/Exit**.

You can reset the calibration parameters back to those set at the factory.

- Press **Menu**, **4**, **6**.
- Press **▲** or **▼** to choose **Reset**.  
Press **OK**.
- Press **1** to choose **Yes**.
- Press **Stop/Exit**.

## Color Registration

### Auto Registration

You can adjust the print position of each color automatically.

- Press **Menu**, **4**, **7**.
  - Press **1** to choose **Start**.
  - Press **Stop/Exit**.
-  To adjust the print position of each color manually, see *Manual Registration* in the *Advanced User's Guide*.

## Brother CreativeCenter Icon



Get inspired. Double-click the Brother CreativeCenter icon on your desktop to access a FREE web site with many ideas and resources for personal and professional use.



<http://www.brother.com/creativecenter/>



# Options and Consumables

## Options

The machine has the following optional accessories. You can expand the capabilities of the machine by adding these items. For more information about the optional Lower Tray Unit and compatible SO-DIMM Memory, visit us at <http://solutions.brother.com/>.

 For installing the SO-DIMM Memory, see *Installing extra memory* in the *Advanced User's Guide*.

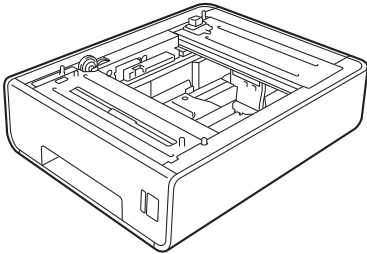
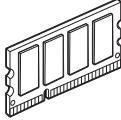
Lower Tray Unit	SO-DIMM Memory
LT-300CL	
<p>The lower paper tray unit can hold up to 500 sheets of paper. When the tray is installed, the machine expands total input capacity up to 800 sheets.</p> 	<p>You can increase the memory by installing one SO-DIMM (Small Outline Dual In-line Memory Module).</p> 

## Consumables

When the time comes to replace consumable items, an error will be indicated by the LCD on the control panel. For more information about the consumables for your machine, visit us at <http://solutions.brother.com/> or contact your local Brother reseller.

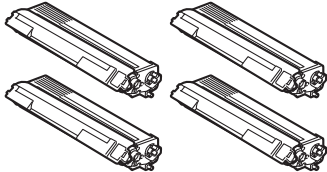
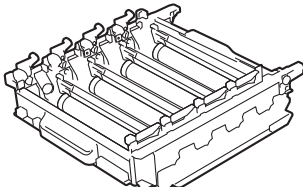
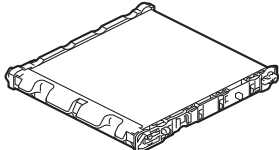
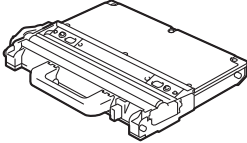
Toner cartridges	Drum unit
<p>Standard Toner: TN-310 (C/M/Y/BK) High Capacity Toner: TN-315 (C/M/Y/BK)</p>	DR-310CL
	
Belt Unit	Waste Toner Box
BU-300CL	WT-300CL
	

## **Trademarks**

The Brother logo is a registered trademark of Brother Industries, Ltd.

Brother is a registered trademark of Brother Industries, Ltd.

Microsoft, Windows, Windows Server and Internet Explorer are registered trademarks of Microsoft Corporation in the United States and/or other countries.

Windows Vista is either a registered trademark or a trademark of Microsoft Corporation in the United States and other countries.

Apple, Macintosh, Safari and TrueType are trademarks of Apple Inc., registered in the United States and other countries.

Nuance, the Nuance logo, PaperPort and ScanSoft are trademarks or registered trademarks of Nuance Communications, Inc. or its affiliates in the United States and/or other countries.

**Any trade names and product names of companies appearing on Brother products, related documents and any other materials are all trademarks or registered trademarks of those respective companies.**

## **Compilation and Publication**

Under the supervision of Brother Industries, Ltd., this manual has been compiled and published, covering the latest product descriptions and specifications.

The contents of this manual and the specifications of this product are subject to change without notice.

Brother reserves the right to make changes without notice in the specifications and materials contained herein and shall not be responsible for any damages (including consequential) caused by reliance on the materials presented, including but not limited to typographical and other errors relating to the publication.

## **Copyright and License**

©2010 Brother Industries, Ltd.

This product includes software developed by the following vendors:

©1983-1998 PACIFIC SOFTWARES, INC.

©2010 Devicescape Software, Inc.

This product includes the "KASAGO TCP/IP" software developed by ZUKEN ELMIC, Inc.